

Oakland Parks and Recreation Advisory Commission (PRAC)
Lakeside Park Garden Center - 666 Bellevue Ave.
Wednesday, March 13th, 2024 at 4:30 PM

Remote Access Instructions and Meeting Agenda

*****NOTE: ZOOM LINK AND ACCESS NUMBER ARE NOW OPEN TO MEMBERS OF THE PUBLIC TO OBSERVE/LISTEN AND PROVIDE COMMENT DURING THE MEETING.**

Zoom Webinar Information:

When: Mar 13, 2024 04:30 PM Pacific Time (US and Canada)

Topic: Parks and Recreation Advisory Commission Meeting - March 13, 2024

Please click the link below to join the webinar:

<https://us06web.zoom.us/j/85019111090>

Or One tap mobile :

+16694449171,,85019111090# US

+16699006833,,85019111090# US (San Jose)

Or Telephone:

Dial(for higher quality, dial a number based on your current location):

+1 669 444 9171 US, +1 669 900 6833 US (San Jose), +1 408 638 0968 US (San Jose),

+1 346 248 7799 US (Houston), +1 719 359 4580 US, +1 253 205 0468 US,

+1 253 215 8782 US (Tacoma), +1 689 278 1000 US, +1 301 715 8592 US (Washington DC),

+1 305 224 1968 US, +1 309 205 3325 US, +1 312 626 6799 US (Chicago), +1 360 209 5623 US,

+1 386 347 5053 US, +1 507 473 4847 US, +1 564 217 2000 US, +1 646 876 9923 US (New York),

+1 646 931 3860 US

Webinar ID: 850 1911 1090

International numbers available: <https://us06web.zoom.us/u/kzL46Bq81>

How To Submit Comments before and during a meeting:

1. To comment by Zoom video conference, click the “Raise Your Hand” button to request to speak when comments are being taken. You will be permitted to speak during your turn, allowed to comment, and after the allotted time, re-muted. Instructions on how to “Raise Your Hand” is available at: https://support.zoom.com/hc/en/article?id=zm_kb&sysparm_article=KB0068290.
2. To comment by phone, please call on one of the above listed phone numbers. You will be prompted to “Raise Your Hand” by pressing “*9” to speak when Open Forum is taken or after an eligible agenda item has been presented. You will be permitted to speak during your turn, allowed to comment, and after the allotted time, re-muted. Please unmute yourself by pressing *6.
3. To submit public comment for review by the Commission before the meeting date, email comments to publiccomments2prac@oaklandca.gov.

If you have questions, email publiccomments2prac@oaklandca.gov or phone Oakland Parks, Recreation and Youth Development @ 510-238-7275. Thank you.



AGENDA
Parks And Recreation Advisory Commission (PRAC)
Lakeside Park Garden Center - 666 Bellevue Ave.
Wednesday, March 13th, 2023 at 4:30 P.M.

*****NOTE: PUBLIC COMMENTS ON ACTION ITEMS WILL BE TAKEN AFTER EACH ITEM OF NEW BUSINESS. ALL PUBLIC COMMENTS WILL BE ACCEPTED UNDER BOTH ITEM 3, OPEN FORUM, AT THE BEGINNING OF THE MEETING AND ITEM 9, CONTINUATION OF OPEN FORUM, AT THE END OF THE MEETING.**

CALL TO ORDER / ROLL CALL

ALPER, BARACH, HENDERSON, KOS-READ, K. SMITH, TORRES, TRAN, WATKINS, AND WHITMORE

1. MODIFICATION OF THE AGENDA:

2. DISPOSITION OF MINUTES:

- January 10th, 2023 Draft Meeting Minutes

3. OPEN FORUM:

Comment on all items will be taken at this time.

4. CONSENT CALENDAR ITEMS:

4A. REQUEST FROM AMERICAN FOUNDATION FOR SUICIDE PREVENTION (AFSP) TO COLLECT ONSITE CHARITABLE DONATIONS AT THE OUT OF THE DARKNESS WALK AT SNOW PARK ON SATURDAY, OCTOBER 19, 2024, FROM 6:00AM – 9:30AM.

4B. REQUEST FROM THE SPANISH SPEAKING CITIZEN’S FOUNDATION FOR APPROVAL TO COLLECT REGISTRATION FEES AND SALES OF PROMOTIONAL MERCHANDISE ONSITE AT THE 5K AZTEC WALK/RUN FOR EDUCATION AT LAKESIDE PARK (PICNIC TABLES NEAR LAKE MERRITT SAILBOAT HOUSE) ON SUNDAY, MAY 5, 2024, FROM 7:00AM-11:00AM.

5. MEASURE Q UPDATE:

*Visit Measure Q [website](#) for more information, documents and reports.

- Informational Report: OPW Monthly Measure Q Report and Performance Measures Update.

6. NEW BUSINESS:

- 6A. REQUEST FROM JAMAICAN AMERICAN COMMUNITY ORGANIZATION (JACO) TO COLLECT FUNDS ONSITE FOR DONATION OF TICKET SALES, THE SALES OF FOOD AND BEVERAGES AT THEIR ANNUAL JULY 4TH FAMILY DAY, TO BE HOSTED AT JOAQUIN MILLER PARK (BA YWOOO AND PINEWOOD PICNIC SITES) ON THURSDAY, JULY 4, 2024, FROM 7:00AM - 8:00PM.
- 6B. REQUEST FROM THE KINGS DELECTABLES FOR APPROVAL TO HAVE ONSITE VENDORS SALES OF FOODS, BEVERAGES AND MERCHADISE AT THE STOP THE VIOLENCE RAP BATTLE TO BE HELD AT LAKE MERRITT BLVD. AMPHITHEATER, SATURDAY, JULY 6, 2024, AT 11:00AM-5:30PM.
- 6C. REQUEST FROM OAKLAND REBELS YOUTH BASKEBALL CLUB TO COLLECT ONSITE DONATIONS, TICKET SALES AT DOOR, SALES OF BEVERAGES (ALCOHOL AND NON-ALCOHOL), RAFFLE TICKETS AND HOST SILENT AND LIVE AUCTION AT THEIR CRAB FEED FUNDRAISER TO BE HOSTED AT LAKESIDE PARK GARDEN CENTER ON SATURDAY MARCH 30, 2024, FROM 4:00PM-9:00PM.
- 6D. INFORMATIONAL REPORT REGARDING THE OAKLAND BALLERS' PROPOSED IMPROVEMENTS TO AND USE OF THE RAIMONDI PARK BASEBALL FIELD.
- 6E. REQUEST FOR THE PARKS AND RECREATION ADVISORY COMISSION TO RECEIVE AN UPDATE ON CITY ACTION AT PINE KNOLL PARK AND MAKE A RECOMMENDATION IN SUPPORT OF A CONDITIONAL USE PERMIT TO REPLACE THE NONFUNCTIONAL BATHROOM IN THE PARK WITH A NEW PORTLAND LOO ON LAKESHORE AVENUE THAT IS ADA COMPLIANT AND TO INSTALL A VEHICLE DETERENT BARRIER AT THE PERIMETER OF THE PARK TO RESTORE PUBLIC ACCESS IN A SAFE AND EQUITABLE MANNER.

7. PLANNING AND CONDITIONAL USE PERMITS:

- 7A. PUBLIC HEARING AND REQUEST FOR THE PARKS AND RECREATION ADVISORY COMMISSION (PRAC) TO MAKE A RECOMMENDATION TO GRANT A MINOR CONDITIONAL USE

**PERMIT FOR PERALTA PARK ENCLOSURE BY A DECORATIVE
EIGHT-FEET HIGH, BLACK STEEL PICKET SECURITY FENCE.**

8. UPDATE FROM DIRECTOR, COMMITTEES, RECREATION ADVISORY COUNCILS &
ANNOUNCEMENTS:
9. CONTINUATION OF OPEN FORUM:
All final comments will be taken at this time.

ADJOURNMENT

Next Meeting:

April 10th, 2024 at 4:30PM

Lakeside Park Garden Center

666 Bellevue Avenue

Oakland, CA 94612

* Visit [PRAC Website](#) for more information, documents, and reports.

This meeting location is wheelchair accessible. To request disability-related accommodations or to request an ASL, Cantonese, Mandarin or Spanish interpreter, please email publiccomments2prac@oaklandca.gov or call Oakland Parks, Recreation and Youth Development at (510) 238-7275 or TDD/TTY (510) 238-3254 at least five working days before the meeting. Please refrain from wearing scented products to this meeting as a courtesy to attendees with chemical sensitivities.

Esta reunión es accesible para sillas de ruedas. Si desea solicitar adaptaciones relacionadas con discapacidades, o para pedir un intérprete de en español, Cantones, Mandarín o de lenguaje de señas (ASL) por favor envíe un correo electrónico a publiccomments2prac@oaklandca.gov o llame al (510) 238-7275 o (510) 238-3254 por lo menos cinco días hábiles antes de la reunión. Se le pide de favor que no use perfumes a esta reunión como cortesía para los que tienen sensibilidad a los productos químicos. Gracias.

會場有適合輪椅出入設施。需要殘障輔助設施, 手語, 西班牙語, 粵語或國語翻譯服務, 請在會議前五個工作天電郵 publiccomments2prac@oaklandca.gov 或致電 (510) 238-7275 或 (510) 238-3254 TDD/TTY。請避免塗搽香氛產品, 參加者可能對化學成分敏感。



MEETING MINUTES
Parks and Recreation Advisory Commission (PRAC)
Wednesday, January 10th, 2023, at 4:30 P.M.
Lakeside Park Garden Center

Meeting Recording Link:

<https://oakland.granicus.com/player/clip/5892?&redirect=true>

CALL TO ORDER / ROLL CALL: 4:30 P.M.

BARACH, DUHE, HA, KOS-READ, D. SMITH, K. SMITH, TORRES, TRAN, WATKINS, AND WHITMORE

Present (8): Chair Tran, Vice Chair Barach, Commissioners Ha, Kos-Read, K. Smith, Torres, Watkins, Whitmore
Excused (1): Commissioner Duhe
Absent (1): Commissioner D. Smith

1. MODIFICATION OF THE AGENDA:

2. DISPOSITION OF MINUTES:

- October 11th, 2023 Draft Meeting Minutes

Motion: Chair Tran entertained a motion to approve the October Meeting Minutes. **Moved by:** Commissioner Kos-Read. **Second by:** Commissioner K. Smith. **Vote:** Yes (7) Tran, Barach, Ha, Kos-Read, K. Smith, Watkins, Whitmore. **Abstain:** (0). **Motion:** Passed.

3. OPEN FORUM: There were 0 speakers and 10 public comments received via email.

4. CONSENT CALENDAR ITEMS:

4A. **REQUEST FROM CENTER FOR EARLY INTERVENTION ON DEAFNESS (CEID) FOR APPROVAL TO COLLECT ON-SITE REGISTRATION FEES AND THE SALES OF RAFFLE TICKETS AT THEIR ANNUAL WALK-A-THON TO BE HELD AT LAKESIDE PARK (FAIRYLAND AREA) ON SATURDAY, MAY 11, 2024, FROM 8:30AM-2:30PM.**

4B. **REQUEST FROM THE NATIONAL MULTIPLE SCLEROSIS SOCIETY FOR APPROVAL TO COLLECT ON-SITE DONATIONS AND PLEDGES**

FOR THEIR ANNUAL WALK MS: OAKLAND 2024 AT LAKESIDE PARK (BANDSTAND) ON SATURDAY, APRIL 20, 2024, FROM 6:00AM-1:00PM.

- 4C. **REQUEST APPROVAL TO ALLOW BAY VENTURES LLC. TO COLLECT FUNDS ONSITE THROUGH VENDOR SALES OF FOOD, BEVERAGES, MERCHANDISE AND ARTISAN SALES AT LAKEFEST 5TH ANNIVERSARY 2-DAY EVENT TO BE HELD AT LAKE MERRITT (LAKE MERRITT SAILBOAT HOUSE, LAKESIDE PARK GARDEN CENTER & SAILBOAT HOUSE PARKING LOT) ON SATURDAY, JUNE 22, 2024, AND SUNDAY, JUNE 23, 2024, 11:00AM-7:00PM.**

Motion: Chair Tran entertained a motion to approve the requests. **Moved by:** Commissioner Ha. **Second by:** Commissioner K. Smith. **Vote:** Yes (7) Tran, Barach, Ha, Kos-Read, K. Smith, Watkins, Whitmore. **Abstain:** (0). **Motion:** Passed.

5. MEASURE Q OVERSIGHT/AD HOC COMMITTEE UPDATE:

*Visit Measure Q [website](#) for more information, documents, and reports.

- Informational Report: OPW Monthly Measure Q Report and Performance Measures Update.

Steven Weiss, OPW Measure Q Program Liaison, introduced the item and OPW staff in attendance: Tom Morgan, Agency Administration Manager, Leslie Liew and Cristy Macias, Business Analysts, Keary Brink, Park Supervisor, and Derin Minor, Building Services Manager.

Michael Houston, Acting City Auditor, informed that report on audit of Measure Q was released on 12/21/2023.

Recess taken due to technical difficulties. Commissioner Torres joined the meeting.

Re-Vote taken for Items 2 and 4 for the remote viewing audience. Both items passed unanimously. Returned to Item 5 presentation.

Michael Houston introduced the report and staff from the City Auditor's Office in attendance: Stephanie Noble, Performance Audit Manager, and Daniel Williams, Senior Performance Auditor.

Michael Houston presented:

The four (4) audit objectives of the Measure Q audit were to: determine if revenue spent was in accordance with the Act, determine if revenue was appropriated in accordance with the Act, determine if park conditions have improved because of the Act, and assess the oversight of activities and expenditures under the Act. Since March 2020, the City of

Oakland has collected \$82.5 billion in taxes to fund park maintenance, litter reduction, and homelessness intervention. Revenue review by the City Auditor is required every two years. Findings show a 22% increase in funding for parks, trees, and ballfields with an increase to 134 staffed positions.

Daniel Williams presented:

Measure Q funds were allocated at 64% to park maintenance, 30% to homelessness services, 5% to stormwater quality, and 1% to audit/evaluation. The City underspent the budget by \$14 million for fiscal years 2020 – 2022. COVID presented challenges with hiring new staff for enhanced park services and non-personnel budget suffered from supply chain issues. As a result, Measure Q fund balance was nearly \$22 million by end of fiscal year 2022 – 2023. Although spending for homelessness services went overbudget, carryforwards or unused funds from the previous year, ensured overall spending stayed within.

The budget recommendation made to the Budget Bureau was to implement controls in the reconciliation of revenue and spending at fiscal year-end to mitigate skewed spending data from carryforwards. Decreased funding and complicated reporting due to the fluctuating 55% threshold set for (minimum) maintenance of effort in parks led to a reduction in services fiscal year over year 2019 – 2021. Additional recommendations were made to City Council and the Budget Bureau to set a policy for establishing maintenance of effort thresholds with a simplified reporting structure, to document selected calculation method for data/reporting consistency, and to establish maintenance of effort method prior to developing future special tax program budgets. To avoid underbudgeting for Measure Q administration costs, the recommendation was made to align the budget with the 1.7% collection fee from the county.

Stephanie Noble presented:

Additional findings show there is a need for more performance data to evaluate effectiveness of Measure Q funds compared to objectives. Outcome measures to show an improvement against a baseline need to be better developed to reflect change over time. In neighboring cities, park conditions drive equity decision-making.

Thus, the performance management recommendations made to the City Administrator's Office, Public Works, and Human Services were to set a measurable baseline for park conditions and numbers of unhoused in and around City parks, to identify baseline performance based on special tax program objectives and report outcomes periodically to City Council. Additional recommendations made to Public Works were to develop park condition standards for the City, to schedule maintenance around them, to implement an annual assessment with report to the PRAC along with assigned staff to report on the

progress of stormwater quality projects. Additional recommendations made to Human Services and the City Administrator's Homeless Division were to develop performance measures aimed at the reduction in the number of unhoused in or around parks and report to the Commission on Homelessness. The additional recommendation made to the City Administrator's Office was for periodic evaluation and reports on special tax program performance compared to baselines and objectives for transparency and public accountability.

Findings also show that the City needs to strengthen its oversight and reporting of Measure Q. The PRAC discussed expenditures and performance at 18 meetings between October 2020 – June 2022 while the Commission on Homelessness only discussed the Act in 3 meetings. The annual financial audit is optional and, although the City budgeted \$100K over fiscal years 2020 – 2022, no financial audit has taken place.

For oversight of homelessness efforts, the recommendations made to the City Administrator's Office and the Commission on Homelessness (COH) were to provide regular operational and expenditure reports to the COH where Measure Q will be discussed as a regular agenda item, for the COH to publish an annual report that includes a section on Measure Q. Additional recommendations were made to the City and the City Administrator's Office to spend the budget allocation for an annual audit of Measure Q funds, and to initiate a best practice policy requiring annual reports on future special tax program revenue, expenditure, and project status.

Public Comment: There was 1 speaker.

Commissioner Torres stated disappointment with the lack of clarity in reporting and the establishment of a baseline/plan to achieve objectives over the past 3 years. Repeated requests for park condition assessments, pictures, and plan development have been made by the PRAC. She added that it would be helpful to have a plan from the findings and assessment on parks and bathrooms with visuals, and requested improvements on the visuals of data collected and reported to clarify what the data is trying to convey. She also requested the plan for hiring.

Michael advised that the City Auditor's Office cannot speak to the City Administrator's plans, however, they look forward to their response and will have an implementation plan thereafter.

Commissioner Watkins stated that he assisted with the creation of the metrics shown as examples from San Francisco and advised that it simply took the establishment of

standards and the follow through of staff doing the work to input the data. Supervisors would go out quarterly, evaluate the whole system, and assess/establish the numbers.

Commissioner Ha asked for clarity around underspending and carryforwards. What category of spending does enhanced park services account for: maintenance or labor hours?

Michael advised it is staff hours and related to the inability to fill positions.

Commissioner Ha acknowledged the report's allocation of spending on homelessness and how such issues also occupy the parks. She asked what is the spending for homelessness. Perhaps, collaboration between PRAC and COH could help better define spending needs.

Michael asserted most spending is for contracts with social service providers as opposed to City staff.

Commissioner Ha also pointed out that the findings helped to uncover the challenges with data collection and outcomes. The Foundation and others have done Oakland park assessments. Perhaps, such data simply needs to be mined to provide a more comprehensive picture of outcomes.

Vice Chair Barach appreciated the focus on outcomes in the audit as the Measure Q data received has been unclear and inaccurate due to a host of issues, but the bottom line is whether the parks are clean not how many times a day we clean them. He asked since the PRAC has struggled as an oversight group to get the information it needs how could it be more effective in its oversight capacity.

Michael advised recommendations were to improve reporting metrics/data and suggested more questions around the metrics and findings.

Commissioner Whitmore agreed with the need to establish a baseline and status assessments but asked about the process for upcoming measurements and who would be involved.

Michael informed that is something the Administration would determine. In general, what is important to measure has to be defined to determine what to measure.

Commissioner Watkins asked why not use metrics that have already been defined like in SF.

Michael agreed that SF's reporting has been super objective and the parks department all worked within the same framework for assessing conditions.

Commissioner Kos-Read assessed the audit was good news in some ways as it is the first in 4 years although it was to happen every two, probably due to same underlying causes for the underspending of Measure Q funds during the pandemic. The PRAC ultimately came to the same conclusions as the audit findings in each of its discussions on Measure Q. He asked what's the City Administrator's timeline for response.

Michael informed there is no statutory timeline for response; however, the City Auditor's policy that will be indemnified as an administrative instruction by City Administration. Audits are participatory so nothing is sprung upon City Administration. A draft report was issued for review and they were provided 2 weeks for a response.

Commissioner Kos-Read asked since there is no leader for the parks and rec, who is reporting on what is happening in the parks, is it Public Works.

Michael informed the maintenance functions are provided by Public Works, so they are reporting.

Commissioner Kos-Read asserted that spending on homelessness services is not aligning with park maintenance needs which could lead to spending more or twice for the same issue if unaddressed. He called for more leadership, management, training and execution, and requested updates on the implementation of the new IT platform as it will be instrumental in forming baselines.

Steven advised that OPW has improved its data collection, but in the new platform will establish a mechanism to track and observe impacts to park assets by the unhoused via work orders (City Works). This information can be queried regularly to see where impacts occur most frequently in conjunction with Human Services and the Encampment Management team. In addition, Public Works will collaborate with OPRYD to work with a third-party consultant to do a parks assessment study and determine baselines this summer. This will be an annual assessment with a report to PRAC.

Commissioner Kos-Read added that in addition to the baseline assessments and new reporting, context needs to be provided with the numbers (e.g., park acreage with respect to labor hours reported, etc.) for proper evaluation. He questioned some of the data from 2023 based on the data breach and park closures.

Steve advised that the technology and staff learning are improving, nonetheless, more information is being put into the system.

Chair Tran ended the discussion and requested further commissioner questions be emailed to her.

6. NEW BUSINESS:

6A. **REQUEST FOR THE PARKS AND RECREATION ADVISORY COMMISSION TO APPROVE THE INSTALLATION OF ART WORKS AT PERALTA HACIENDA HISTORICAL PARK.**

Felicia Gotthelf, OPRYD Management Assistant, introduced the request and speaker, Holly Alonso, Executive Director of Friends of Peralta Hacienda Historical Park. Holly presented that the group seeks to decolonize the park through the installation of art that makes visible the Native American history of the site. The Peraltas were there 40 years, but the Native Americans were there more than 4000 years. Fruitvale has a huge, diverse indigenous identity and community. When brought together and asked what they would like, they shared the desire to be seen, for their arts and culture to be visible, and language acknowledged. The art installation will be comprised of two elements: Ohlone word sculpture for Sun, Moon, and Water, and a series of signs with illustrations. This is fully funded. The Friends group will maintain the works.

Public Comment: There were 0 speakers.

Commissioner Kos-Read advised the group to consider how to make the sculptures interactive and engaging to those living near the park.

Commissioner Barach pointed out that the structure appears to be something children may want to climb on which is not its intent.

Holly clarified that the structure would be seasonally woven and replenished to make it an art project to the community of traditional artists. Though it will be meant for minimal interactivity like being touched, Holly will need to follow up with the designer for more detail.

Commissioner Torres asked about signage and translations.

Holly confirmed there will be signs in the Ohlone language, Spanish, and English. She also advised of the inclusive nature of the word sculpture as the words come from Maya Angelou's poem "Still I Rise".

Motion: Chair Tran entertained a motion to approve the request. **Moved by:** Commissioner K. Smith. **Second by:** Commissioner Torres. **Vote:** Yes (8) Tran, Barach, Ha, Kos-Read, K. Smith, Torres, Watkins, Whitmore. **Abstain:** (0). **Motion:** Passed.

6B. **REQUEST FOR THE PARKS AND RECREATION ADVISORY COMMISSION TO APPROVE A GIFT-IN-PLACE DONATION IN THE AMOUNT NOT TO EXCEED \$18,750.00 FROM THE FRIENDS OF JOAQUIN MILLER (FOJMP) AND TO ENTER INTO A RIGHT OF ENTRY CONTRACT WITH ARTISTS TO PAINT MURAL ART ON EXTERIOR WALLS OF TWO BATHROOMS AT JOAQUIN MILLER PARK.**

Quincy Williams, OPRYD Assistant Capital Improvement Projects Coordinator, presented the request and introduced representative Julie Mills of the FOJMP. The murals will appear at the Cascade and Redwood Glen to beautify the spaces by two artists. No fiscal impact to the City. It will incorporate Native American art and history of the land.

Public Comment: There was 1 speaker.

Motion: Chair Tran entertained a motion to approve the request. **Moved by:** Commissioner Kos-Read. **Second by:** Commissioner K. Smith. **Vote:** Yes (8) Tran, Barach, Ha, Kos-Read, K. Smith, Torres, Watkins, Whitmore. **Abstain:** (0). **Motion:** Passed.

6C. **REQUEST FOR THE PARKS AND RECREATION ADVISORY COMMISSION TO APPROVE A GIFT-IN-PLACE DONATION IN THE AMOUNT NOT TO EXCEED \$5,000 FROM THE DIMOND IMPROVEMT ASSOCIATION (DIA)AND TO ENTER \$1 CONSTRUCTION CONTRACT WITH SELECTED VENDOR TO INSTALL A METAL AND CONCRETE PIECE OF ART IN THE FORM OF AN ELLIPTICAL AT THE DIMOND GATEWAY GARDEN.**

Quincy Williams, OPRYD Assistant Capital Improvement Projects Coordinator, introduced the request and speaker, Andrea Bacigalupo (artist). There will be no fiscal impact to the City. Andrea is an Oakland resident that lives and works in the area. There is a lot of transit nearby and patrons tend to sit on the benches. The art piece has been specifically engineered for that space.

Public Comment: There were 0 speakers.

Motion: Chair Tran entertained a motion to approve the request. **Moved by:** Vice Chair Barach. **Second by:** Commissioner K. Smith. **Vote:** Yes (8) Tran, Barach, Ha, Kos-Read, K. Smith, Torres, Watkins, Whitmore. **Abstain:** (0). **Motion:** Passed.

6I. **REQUEST FOR THE PARKS AND RECREATION ADVISORY COMMISSION TO APPROVE THE OAKLAND BALLER'S (OAKLAND B'S) TO COLLECT GATE FEES, TEAM MERCHANDISE FOOD, AND**

BERVERAGES AT RAIMONDI BASEBALL FIELD.

Frederick Morris III, OPRYD Sports Unit, introduced the request. Oakland Ballers, an adult pro-baseball group would like to utilize the Raimondi baseball field. Paul Freedman, co-founder, presented. Sports bring diverse communities together. In Oakland, baseball has brought communities together more than any other and the Oakland B's were founded to ensure this rich history continues. Raimondi field is also entrenched in this history as well, being a home field for pro-players growing up. Activating this field for use will also provide players at tournaments and clinics the opportunity to earn stats for recruitment by colleges and pro-teams.

Public Comment: There were 2 speakers.

Commissioner Barach had questions on logistics.

Frederick advised that they have engaged community members, warehouse owners, train station, and AC Transit. The goal is to have patrons ride BART to Oakland and have AC Transit shuttle service to the field. Mike Ford, Department of Transportation Project Manager, offered some suggestions. Managing traffic in and out of field is being considered along with security and parking enforcement. Desire to bring 1,000 – 1,500 seats to stadium. Porto potties will be installed, and ticket prices set.

Commissioner Barach asked about time of day for games.

Frederick advised that there will be night games, however, other teams also use the field: youth football/cheer East Bay Warriors, McClymonds High School, and a pro-soccer team. The high school and OUSD have agreed to change the baseball playoff schedule from evening to early afternoons.

Commissioner Barach asked about neighbors, traffic, and noise considerations.

Frederick explained that currently the park is experiencing some traffic congestion with existing use. Thus, the ongoing work of mitigating this concern through discussions on the use of the train station for overflow parking and AC Transit partnership.

Paul added that in a recent community engagement meeting of about 50 participants, all were in favor of activating the park.

Commissioner Ha expressed enthusiasm for the proposal and asked for the timeline and duration of request.

Frederick informed there are 48 dates requested for Oakland B's field use.

Paul added that the request is for just one season at this time.

Commissioner Kos-Read noted that although the request was on the agenda, it was not

included in the packet.

Commissioner Torres requested the consideration of data/metrics around equity of access to the park, especially in the summer.

Commissioner Kos-Read asserted considering the massive public support for the proposal, if there is neither opposition to the item nor legal constraints on taking a vote, he was willing to move forward and approve the request.

Commissioners agreed to move onto the next agenda item while staff confirmed whether action could be taken on this item.

6D. **REQUEST FOR THE PARKS AND RECREATION ADVISORY COMMISSION TO RECOMMEND ADOPTION OF AN ORDINANCE AUTHORIZING THE CITY ADMINISTRATOR TO NEGOTIATE AND EXECUTE A LICENSE AGREEMENT WITH TRYBE, INC., A CALIFORNIA NONPROFIT ORGANIZATION AT A BELOW MARKET RATE.**

Cinthya Munoz Ramos from Office of CM Bas presented the request. The below-market-rate value requested at \$0 from March 1, 2024 – February 28, 2025. Goal is to create a safe, accessible community center in the park. The park and center have been underutilized for multiple marginalized communities. This will provide resources and programming to an underserved/-invested area for elders/seniors, youth, immigrants and refugees, local religious institutions, businesses/merchants, among others. Community survey showed desire for various types of programming and services from fitness and musical performances to community meetings. In 2021, arson damaged about 30% of the building and has remained. Community engagement from 8 organizations reached thousands of community members. Trybe would manage the administration of services/programming and the center over the year lease. This model has been going successfully for the past 4 months.

Public Comment: There were 2 speakers.

Commissioner K. Smith shared his experience working with Trybe and the community work.

Commissioners Torres, Ha, and Kos-Read shared enthusiasm for the proposal.

Motion: Chair Tran entertained a motion to approve the request. **Moved by:** Commissioner K. Smith. **Second by:** Commissioner Kos-Read. **Vote:** Yes (8) Tran, Barach, Ha, Kos-Read, K. Smith, Torres, Watkins, Whitmore. **Abstain:** (0). **Motion:** Passed.

6I. **REQUEST FOR THE PARKS AND RECREATION ADVISORY COMMISSION TO APPROVE THE OAKLAND BALLER'S (OAKLAND**

B'S) TO COLLECT GATE FEES, TEAM MERCHANDISE FOOD, AND BEVERAGES AT RAIMONDI BASEBALL FIELD.

Commissioners revisited item to review the full report and take a vote.

Commissioner Kos-Read asked about the number of consecutive days of gameplay.

Frederick clarified that some gamedays will be consecutive while others will not, similar to the schedule of the Golden State Warriors or Oakland A's.

Paul added there will be no games on Mondays.

Commissioner Barach asked if the organization was for-profit and if the field would be accessible on the organization's off days.

Paul advised that it is a for-profit organization.

Frederick confirmed access to the field as it is and will continue to be a shared space.

Chair Tran asked what portion of fee of \$18K will go towards the City.

Frederick advised it is a requisite for field rental from the Master Fee Schedule that will go into the General Fund. He informed that the organization is following the traditional rental process for this season in hopes of building a partnership in the future.

Commissioner Barach voiced concerns with community engagement.

Frederick assured community members engaged were from the Raimondi community committee and several other meetings have been held by other City staff.

CM Fife advised that community engagement will continue though many, including those in a nearby apartment building, have been touched and are in support of the effort as the area was previously home to a large encampment. The activation of the park will help to further improve the revitalization of the community. At this time, the only foreseeable concern is traffic, which is being addressed in ongoing discussions.

Commissioner Torres requested, with the ongoing engagement, that concerns/complaints with traffic or noise voiced by the community and the resolution be brought to the commission so that they can be addressed with the public at large to assist with moving the project along.

Motion: Chair Tran entertained a motion to approve the request. **Moved by:** Commissioner K. Smith. **Second by:** Commissioner Ha. **Vote:** Yes (8) Tran, Barach, Ha, Kos-Read, K. Smith, Torres, Watkins, Whitmore. **Abstain:** (0). **Motion:** Passed.

6E. **RECEIVE AN ORAL REPORT FROM THE OFFICE OF THE CITY CLERK TO FURTHER INFORM AND INCREASE BOARD AND COMMISSION MEMBER'S COMPLIANCE WITH THE TIMELY FILING OF ALL STATEMENT OF ECONOMIC INTERESTS STATEMENTS ALSO KNOWN AS FORM 700.**

Britney Davis, Assistant City Clerk, introduced the request and Krystal Sams, Legislative Recorder, Office of the City Clerk. Oath of Office is the first responsibility of commissioners, administered by Office of the City Clerk, and required before commissioners may participate in a meeting. Form 700 account is created during this appointment.

Cover page is always required, even when there is nothing to disclose. Form 700 is also known as the Statement of Economic Interests. It must be filed within 30 days of assuming office, annually by April 1st or the following Monday, within 30 days of separation, and immediately if there are any amendments. File form 700 via Netfile online and provide a hardcopy with wet signature to the Office of the City Clerk. No copies are allowed. Late statements are fined \$10/day up to \$100. Failure to file can result in a referral to the California Fair Political Practices Commission, additional fines, prosecution, and cause for removal.

Britney Davis advised the following Commissioners are not in compliance: Torres for years 2022 - 2023, D. Smith for 2023, and Watkins contact Office of City Clerk.

Public Comment: There were 0 speakers.

Motion: Chair Tran entertained a motion to approve the request. **Moved by:** Commissioner Kos-Read. **Second by:** Commissioner Ha. **Vote:** Yes (8) Tran, Barach, Ha, Kos-Read, K. Smith, Torres, Watkins, Whitmore. **Abstain:** (0). **Motion:** Passed.

Commissioner Torres left the meeting.

6F. **REQUEST APPROVAL FROM THE PARKS AND RECREATION ADVISORY COMMISSION TO ALLOW THE SEQUOIA ELEMENTARY PARENT TEACHER ORGANIZATION (SPTO) PERMISSION TO COLLECT ONSITE DONATIONS, TICKET SALES AT DOOR AND HOST A SILENT/LIVE AUCTION FUNDRAISER AT LAKE MERRITT SAILBOAT HOUSE ON SATURDAY MARCH 02, 2024, FROM 1:00PM-10:00PM.**

Alan Phan, OPRYD Public Service Representative, introduced the request and speaker, Jon Guiliano, Co-Fundraising Chair of the SPTO. Jon informed that OUSD does not provide enough funds for programs so fundraising is needed throughout the year. This will be the first fundraiser since Covid with an anticipated headcount of 100 – 120 people

for the crab feed. The goal is to make this an annual event and tradition for SPTO.

Public Comment: There were 0 speakers.

Chair Tran asked about ticket prices.

Jon advised tickets will be \$60, some will be raffled to the community and some spaces held for volunteers. The goal is to fund the Sequoia Fund which has earmarked measures for the Oakland Equity Fund (goes to schools without PTAs/PTOs/fundraising capacities). The goal is to provide 7 schools over the next 3 years \$25K – 40K each year.

Commissioner Kos-Read advised to be mindful of sound levels after 9pm as they can be heard across the lake.

Motion: Chair Tran entertained a motion to approve the request. **Moved by:** Commissioner Kos-Read. **Second by:** Commissioner K. Smith. **Vote:** Yes (7) Tran, Barach, Ha, Kos-Read, K. Smith, Watkins, Whitmore. **Abstain:** (0). **Motion:** Passed.

6G. **REQUEST APPROVAL TO ALLOW THE CRISIS SUPPORT SERVICES TO COLLECT ONSITE REGISTRATIONS AND DONATIONS FROM SUPPORTERS AT THEIR 5K HEALING HEARTS WALK/RUN FOR SUICIDE PREVENTION TO BE HELD AT LAKESIDE PARK (BANDSTAND) ON SATURDAY, MAY 4, 2024, FROM 7:00AM -1:00PM.**

Tanya Nicholson, OPRYD Public Service Representative, introduced the request and speaker Rich Gelber, Development Coordinator for Crisis Support Services in Alameda County. The event last took place in 2019 and each year for 8 years prior. This is the major fundraising event for the year to support crisis support services. The event is free and has a recommended donation. This year there will be other movement activities such as Tai Chi.

Public Comment: There were 0 speakers.

Commissioner Kos-Read offered to provide dance group contacts for the event.

Commissioner K. Smith acknowledged the important work of crisis support.

Motion: Chair Tran entertained a motion to approve the request. **Moved by:** Commissioner K. Smith. **Second by:** Commissioner Watkins. **Vote:** Yes (7) Tran, Barach, Ha, Kos-Read, K. Smith, Watkins, Whitmore. **Abstain:** (0). **Motion:** Passed.

6H. **REQUEST FROM THE LOWER GRAND RADIO FOR APPROVAL TO COLLECT ON-SITE DOOR DONATIONS, VENDOR FEES, VENDOR**

SELLS OF WARES, NON-ALCOHOL AND ALCOHOL BEVERAGES AT THE ONE-DAY CRAFT AND MAKER FAIR TO BE HELD AT LAKESIDE PARK GARDEN CENTER ON SUNDAY, MARCH 24, 2024, 9:00AM-6:00PM.

Tanya Nicholson, OPRYD Public Service Representative, introduced the request and speaker, Alex Shen, Founder and Station Manager of Lower Grand Radio. Alex informed that he started the internet radio station 10 years ago in his garage. Since then programming has grown to 115 monthly shows and a studio on 41st & Broadway. The objective is to give a platform and elevate aspiring DJs and music enthusiasts, and to provide a space where they can hone their craft. This event will be a fundraiser. Many of the station's DJs and musicians in the community are also artists, so this will be a way to showcase the station and artist work. The event will be free with donations recommended.

Public Comment: There were 0 speakers.

Motion: Chair Tran entertained a motion to approve the request. **Moved by:** Vice Chair Barach. **Second by:** Commissioner Ha. **Vote:** Yes (7) Tran, Barach, Ha, Kos-Read, K. Smith, Watkins, Whitmore. **Abstain:** (0). **Motion:** Passed.

7. PLANNING AND CONDITIONAL USE PERMITS:

7A. **CONDITIONAL USE PERMIT FOR COURTLAND CREEK RESTORATION PROJECT AT COURTLAND CREEK PARK.**

Quincy Williams, OPRYD Assistant Capital Improvement Coordinator, introduced the request and speaker, Jennifer Stern of OPW Watersheds. Park is located near Brookdale and High Street. Informational report was brought to PRAC in January 2023. Requesting recommendation for approval of the permit. Creek restoration has been completed. Next phase is the park improvement including seating, signage, fencing, trash receptacles and picnic tables. The extensive community engagement has brought suggestions and support for the project.

Public Comment: There was 1 speaker.

Commissioner Ha requested information regarding the stewardship of the creek and park.

Jennifer informed the Friends of Courtland Creek has been reinvigorated because of the project and were the group that created the park that worked 10 years to get it. Some of the original members are still involved. The group has monthly meetings and are codeveloping a stewardship guide with OPW for the community.

Chair Tran requested clarification on the Conditional Use Permit approval process.

Quincy advised that part of the process for projects in open spaces requires PRAC recommendation. Zoning makes the final decision, nonetheless, the whole community has investment in these areas. Thus, it is customary to get the PRAC recommendation as an additional level of feedback before a final decision is made.

Motion: Chair Tran entertained a motion to approve the request. **Moved by:** Commissioner Ha. **Second by:** Commissioner Watkins. **Vote:** Yes (7) Tran, Barach, Ha, Kos-Read, K. Smith, Watkins, Whitmore. **Abstain:** (0). **Motion:** Passed.

7B. **REQUEST FOR THE PARKS AND RECREATION ADVISORY COMMISSION (PRAC) TO SUPPORT A MINOR CONDITIONAL USE PERMIT FOR THE SOBRANTE PARK RENOVATION PROJECT.**

Tess Kavanaugh, OPW Project Manager for Sobrante Park Renovation Project, introduced Don Kim, Project Architect of Dialog Design, and presented the request. This will assist with acquiring the building permit and the construction phase. The project is a partnership between the City of Oakland and Sobrante Park community groups. Working with a local landscape architect they developed a plan for improvements and teamed up with OPW to submit a grant and received \$2.6MIL from the State. In addition, the remainder of Measure U funds were added to fund a total project budget of \$5MIL with construction totaling \$3.5MIL. The goal is to reactivate the park provide safe and engaging play/exercise opportunities, space to experience nature and support mental health, and dedicated space for community members to gather with the new community building.

Public Comment: There were 0 speakers.

Commissioner Ha asked about park hours and relationship with schools, and the modular structure's use.

Tess advised the City has an agreement with OUSD regarding the lease of the property, maintenance, and operation of the park. It will be fenced and open from dawn to dusk. Working with OPRYD and community groups to develop programming for the space. Various community groups are interested in using the space. OPW will provide park access and OPRYD will drive programming.

Commissioner Kos-Read advised of other charter schools that might support partnerships as one listed in the report no longer exists. He also raised concern around the lack of community represented in the meeting or letter of support in the report.

Tess clarified that it was simply an oversight on her part on getting that letter. Sylvia Brooks, President of Sobrante Park Resident Action Council, was to attend this meeting but had a scheduling conflict. However, a letter from her can be provided at a later date. Since approval is likely assumed, the community is more focused on getting the project completed and open as soon as possible.

Motion: Chair Tran entertained a motion to approve the request. **Moved by:** Commissioner Watkins. **Second by:** Commissioner Kos-Read. **Vote:** Yes (7) Tran, Barach, Ha, Kos-Read, K. Smith, Watkins, Whitmore. **Abstain:** (0). **Motion:** Passed.

8. UPDATE FROM DIRECTOR, COMMITTEES, RECREATION ADVISORY COUNCILS & ANNOUNCEMENTS:

Director's Report:

- No updates.

PRAC Committees:

- No updates.

Chair Tran shared that Vice Chair Barach and she met with City Administrator Jestin Johnson to discuss the merger. They agreed to include Vice Chair Barach as a part of that process. Will provide updates as they develop.

Recreation Advisory Councils (RACs):

- Commissioner Ha advised she will work with Chair offline to draft letter in support of volunteer efforts to plant trees for a memorial grove at San Antonio Park to be on upcoming agenda.

Announcements:

- February will be Commissioner Ha's last meeting with PRAC as she will be terming out.
- Mother of the Year nominations are open until 4pm on March 15th.

9. OPEN FORUM: There were 0 speakers.

10. ADJOURNMENT: 8:29 p.m.

*Visit [PRAC Website](#) for more information, documents, and reports.

Next Meeting:

Wednesday, February 14th, 2024, at 4:30 pm

Lakeside Park Garden Center

666 Bellevue Avenue

Oakland, CA 94612

Via Zoom

(For observation purposes only.)

Respectfully Submitted,



Jasmine S. Bellow
Executive Assistant to the Director
Recording Secretary

CITY OF OAKLAND
Oakland Parks, Recreation & Youth Development



TO: Tam Tran, Vice-Chair, Parks and Recreation Advisory Commission
FROM: Tanya Nicholson, Public Service Representative
DATE: January 12, 2024
SUBJECT: REQUEST FROM AMERICAN FOUNDATION FOR SUICIDE PREVENTION (AFSP) TO COLLECT ONSITE CHARITABLE DONATIONS AT THE OUT OF THE DARKNESS WALK AT SNOW PARK ON SATURDAY, OCTOBER 19, 2024, FROM 6:00AM – 9:30AM

SUMMARY

Oakland Parks and Recreation received a request from American Foundation for Suicide Prevention (AFSP), a non-profit organization that fund research to improve interventions, train clinicians in suicide prevention, and advocate for policy that will save lives. AFSP is requesting to solicit on-site charitable donations from supporters at their Out of Darkness Walk to be held at Snow Park on Saturday, October 19, 2024, 6:00am – 9:30am. 100% of the donations collected will benefit prevention and education about suicide with 50% of the funds retained locally for crisis support in the Bay Area. The applicant is aware of the additional permits required. Approval from the Parks and Recreation Advisory Commission is required per O.M.C. section 12.64.080.

FISCAL IMPACT

American Foundation for Suicide Prevention will pay all fees associated with this event which is estimated at a total of \$572.00.

PROJECT / PROGRAM DESCRIPTION

American Foundation for Suicide Prevention has held the Out of the Darkness Walk at the Lakeside Park Pergola location beginning in 2009, this will be the first-year hosting at Snow Park due to the Pergola Area being heavily impacted by the Global Pandemic; each year's event has been successful. This event consists of participants representing survivors of suicide, who have collected sponsorship donations for the education and distribution of information about suicide awareness and prevention. This event is open to the public and typically collects approximately \$5,000 onsite. The sole purpose of this event is to raise funds for suicide prevention awareness.

BACKGROUND / LEGISLATIVE HISTORY

American Foundation for Suicide Prevention was established in 1987, it's a voluntary health organization that gives those affected by suicide a nationwide community empowered by research, education, and advocacy. AFSP is dedicated to saving lives and bringing hope to those affected by suicide. AFSP created a culture that's smart about mental health by engaging in the following core strategies:

- Funding scientific research
- Educating the public about mental health and suicide prevention

- Advocating for public policies in mental health and suicide prevention
- Supporting survivors of suicide loss and those affected by suicide in our mission

RECOMMENDATION

Staff recommends that the Park and Recreation Advisory Commission approve the request to allow the American Foundation for Suicide Prevention to collect donations onsite at their Out of Darkness Walk at Snow Park on Saturday, October 19, 2024, 6:00am-9:30am.

Respectfully submitted,

/s/ Tanya Nicholson

Prepared by:

Tanya Nicholson

Public Service Representative

/s/ Zermaine Thomas

Approved by:

Zermaine Thomas

Special Events Coordinator

Attachments: Exhibit A - American Foundation for Suicide Prevention Request Letter
Exhibit B – American Foundation of Suicide Prevention Non-Profit Certificate 501c3
Exhibit C – Post Event Report (2022) Note: Group Cancelled 2023 Event



**American
Foundation
for Suicide
Prevention**



January 10, 2024

To Oakland Parks and Recreation Advisory Commission:

This is a request from the American Foundation for Suicide Prevention, a 501(c)3 nonprofit organization recognized by the federal government (Tax ID # 13-3393329), for permission host a suicide prevention awareness walk-a-thon on Saturday October 19, 2024, from 6:00 am to 9:30 am and to collect donations at Snow Park preceding a walk around Lake Merritt. 100% of the proceeds from this event will benefit lifesaving research studies, prevention education programs for communities and schools, and support programs for survivors of suicide loss with 50% of the funds retained locally for crisis support in the Bay Area and the local Greater San Francisco Bay Area Chapter of the American Foundation for Suicide Prevention.

This is planned to be the annual 17th Community Out of the Darkness Walk in Oakland following the same event held at this location in 2022 or formerly at the Pergola annually since 2009, excluding pandemic years. The event will consist of participants representing survivors of suicide and those with lived experience, who have collected sponsorship donations for the education and distribution of information about suicide awareness and prevention. Participants would check-in, receive a T-shirt and then listen to guest speakers as part of an inspiration opening ceremony. Some registration will occur on site with voluntary donations collected. After a short introduction to the event, they will walk together around the Lake and will be greeted at completion with brochures and certificates of completion. We typically collect approximately \$5,000 on site.

Community partners working in suicide prevention, mental health, grief support, and community services may attend and provide mental health resource information or literature as part of our Mental Health Resource Fair, but we do not have vendors selling goods nor food. Fees are not required to participate in the walk.

This event is open to the public, and all are welcome and encouraged to join as we share the AFSP mission to save lives and bring hope to all that have been affected by suicide. The sole purpose of this event is to raise funds for suicide prevention and awareness.

Please do not hesitate to contact me at the number below or my Area Director, Christina Huntress, at 707-721-4062 with any additional questions. Thank you for your consideration as we work to save lives and prevent suicide in Oakland and nationwide.

Sincerely,

Annemarie Domizio, Walk Chair
25119th Ave, Oakland, CA 94606
afsp.oaklandcawalk@gmail.com
415-939-1764

Christina Huntress, Area Director
2365 Napa St #3557, Vallejo, CA 94591
chuntress@afsp.org
(707) 721-4062

American Foundation for Suicide Prevention
199 Water Street, 11th Floor, New York, NY 10038 | 1-888-333-AFSP (2377) | info@afsp.org | Tax ID: 13-3393329

**Exhibit A - American Foundation for Suicide Prevention Request Letter
PRAC Item 4A - March 13, 2024**

INTERNAL REVENUE SERVICE
DISTRICT DIRECTOR
G.P.O. BOX 1680
BROOKLYN, NY 11202

DEPARTMENT OF THE TREASURY

Date: NOV 19 1991

Employer Identification Number:
18-3393329

Contact Person:
FRED HYMNOWITZ

Contact Telephone Number:
(718) 790-6114

AMERICAN SUICIDE FOUNDATION
1045 PARK AVENUE
NEW YORK, NY 10028

Our Letter Dated:
July 6, 1987

Addendum Applies:
NO

Dear Applicant:

This modifies our letter of the above date in which we stated that you would be treated as an organization which is not a private foundation until the expiration of your advance ruling period.

Your exempt status under section 501(a) of the Internal Revenue Code as an organization described in section 501(c)(3) is still in effect. Based on the information you submitted, we have determined that you are not a private foundation within the meaning of section 509(a) of the code because you are an organization of the type described in section 509(a)(1) and 170(b)(1)(A)(vi).

Grantors and contributors may rely on this determination unless the Internal Revenue Service publishes notice to the contrary. However, if you lose your section 509(a)(1) status, a grantor or contributor may not rely on this determination if he or she was in part responsible for, or was aware of, the act or failure to act, or the substantial or material change on the part of the organization that resulted in your loss of such status, or if he or she acquired knowledge that the Internal Revenue Service had given notice that you would no longer be classified as a section 509(a)(1) organization.

As of January 1, 1984, you are liable for taxes under the Federal Insurance Contributions Act (social Security taxes) on remuneration of \$100 or more you pay to each of your employees during a calendar year. You are not liable for the tax imposed under the Federal Unemployment Tax Act (FUTA).

You are required to file Form 990 only if your gross receipts each year are normally more than \$25,000. For guidance in determining whether your gross receipts are "normally" more than \$25,000, see the instructions for Form 990. If a return is required, it must be filed by the 15th day of the fifth month after the end of your annual accounting period. A penalty of \$10 a day is charged when a return is filed late, unless there is reasonable cause for the delay. However, the maximum penalty charged cannot exceed \$5,000 or 5 percent of your gross receipts for the year, whichever is less. This penalty may also be charged if a return is not complete, so please be sure your return is complete before you file it.

If we have indicated in the heading of this letter that an addendum applies, the addendum enclosed is an integral part of this letter.

-2-

AMERICAN SUICIDE FOUNDATION

Because this letter could help resolve any questions about your private foundation status, please keep it in your permanent records.

If you have any questions, please contact the person whose name and telephone number are shown above.

Sincerely yours,

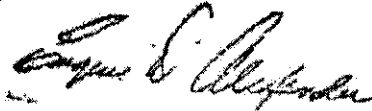

Eugene D. Alexander
District Director



POST EVENT REPORT

Please complete and return the Post Event Report within 30 days after event date to Oakland Parks and Recreation Central Reservations Unit at 250 Frank H. Ogawa Plaza, 3rd Floor, Suite 3330, Oakland, CA 94612. If the event was held at a Recreation Center site, return the Post Event Report to the Site Supervisor at the Recreation Center.

I. GENERAL INFORMATION

Name of Event: American Foundation for Suicide Prevention
Out of the Darkness Community Walk

Location of Event: Swan Park

Date/Hours of Event: 10/15/2022 Permit No. FA-55544

Contact Person: Teresa Ferguson Phone No. 510 292-5211

Contact Person Address: 1047 Alvarado Rd Berkeley, CA 94705

Is this a first time event at this location? Yes No If no, when was the event held previously? Held previously at Pergola Lake Merritt in 2009-2019 annually

1. Were Facility Rental/Set-up fees waived? Yes No Not Applicable
2. Check other permits required for event?
- | | | |
|---|--|--|
| <input checked="" type="checkbox"/> OPD Special Events Permit | <input type="checkbox"/> Food Handler's Permit | <input type="checkbox"/> Seller's Permit |
| <input checked="" type="checkbox"/> Charitable Solicitations Permit | <input checked="" type="checkbox"/> Certificate of Insurance | <input type="checkbox"/> Other - Please list |

II. ATTENDANCE/COLLECTION OF FUNDS

1. Total number in attendance: 250
2. Were registration or donation fees collected on-site for the event? Yes No Not Applicable
3. If yes, how many people registered? 20 onsite How many people made donations? 0
4. What was the cost for registration? NONE
5. How much money was collected on site for registration fees? none
6. How much money was collected on site for donations? less than \$100

Revised: 04-2013

III. VENDOR INFORMATION

List all Vendors who participated at the event. (Attach additional sheets, if necessary):

Were all vendors in compliance per agreement? Yes No *N/A*

Of no, why not? *no vendors*

Name of Vendor(s) (Attach additional sheets if necessary)	Non-Profit or For Profit Orgz'n?	Food (Describe)	Craft (Describe)	Seller's Permit Y/N
<i>we do not have vendors selling products</i>				

IV. COMMENTS

List ways in which the Applicant desires to improve the event, in the future (Attach additional sheets, if necessary): (For example: changes or additional vendors, location, change of hours, etc.)

no changes needed

List any problems, concerns, or, other comments about your satisfaction in the way the event turned out? (Attach additional sheets, if necessary):

trash bins were full so had to be emptied prior to event but we brought our own so was manageable.

Submitted by: *Debra M. [Signature]* Date: *10/28/2022*

Approved by: *Rebecca Roman* (OPR Staff) Date: *10/2022*

Comments: *Central Reservations staff will work with Oakland Public Works to ensure trash bins are emptied,*



CITY OF OAKLAND
Oakland Parks, Recreation & Youth Development

TO: Tam Tran, Chair, Parks & Recreation Advisory Commission
FROM: Tanya Nicholson, Public Service Representative
DATE: January 17, 2024
SUBJECT: REQUEST FROM THE SPANISH SPEAKING CITIZEN'S FOUNDATION FOR APPROVAL TO COLLECT REGISTRATION FEES AND SALES OF PROMOTIONAL MERRCHANDISE ONSITE AT THE 5K AZTEC WALK/RUN FOR EDUCATION AT LAKESIDE PARK (PICNIC TABLES NEAR LAKE MERRITT SAILBOAT HOUSE) ON SUNDAY, MAY 5, 2024, FROM 7:00AM-11:00AM.

SUMMARY

Oakland Parks, Recreation & Youth Development received a request from the Spanish Speaking Citizen's Foundation (SSCF), a 501(c)(3) non-profit organization located in the heart of the vibrant Fruitvale neighborhood. SSCF has been providing services to the community since 1965. Their programs and services continue to be relevant and reflect the ever-changing needs of the Latina/o/e/x community. The Spanish Speaking Citizen's Foundation is requesting approval to collect onsite registration fees and sales of promotional merchandise at their 5K Aztec Walk/Run for Education. The applicant is aware of the additional permits required. Approval from the Parks and Recreation Advisory Commission is required per O.M.C. Section 12.64.080.

FISCAL IMPACT

There will be a positive fiscal impact to Oakland Parks & Recreation. The Spanish Speaking Citizen's Foundation is paying all rental fees associated with the event estimated at \$540.00.

PROJECT / PROGRAM DESCRIPTION

The Aztec Run for Education, a 5K run/walk, is a fun-filled, family-friendly event to build relationships, strengthen social connections, and to celebrate being in community. Their first Aztec Run for Education began in 1983 and they are excited to continue this long tradition. In past years, the 5K run/walk goes once around beautiful Lake Merritt in Oakland, CA. Their supporters include runners, walkers, volunteers, clients, sponsors, donors, and dancers! Participation is open to all ages, all running/walking levels, accessible to those living with disabilities

BACKGROUND / LEGISLATIVE HISTORY

The Spanish Speaking Citizen's Foundation has been providing services to the community since 1965. They offer programs and services in three areas: 1) immigration and citizenship assistance, 2) educational and workforce development for youth and adults, and 3) information and referral. SSCF's services focus on helping Spanish-speaking youth and immigrants elevate their voice, presence, participation, and power to improve quality of life while celebrating the common cultural heritage of recent and long-term residents,

RECOMMENDATION

Staff recommends that the Parks and Recreation Advisory Commission approve the request from the Spanish Speaking Citizen's Foundation to collect registration fees and sales of promotional merchandise onsite at their 5k Aztec Walk/Run for Education at the Lakeside Park (Picnic Tables near Lake Merritt Sailboat House) on Sunday, May 5, 2024, from 7:00am-11:00am.

Respectfully submitted,

/s/ Tanya Nicholson

Prepared by:

Tanya Nicholson

Public Service Representative

/s/ Zermaine Thomas

Approved by:

Zermaine Thomas

Special Events Coordinator

Attachments: Exhibit A – Spanish Speaking Citizen's Foundation Proposal Letter
Exhibit B – Non-Profit Certificate (501c3)
Exhibit C – Post Event Report (2023)

Board of Directors:
Ramon Rodriguez - President
Francisco Vera - Vice-President
Bob Schutt - Treasurer and Secretary
Victoria Martin - Trustee
Ken Maxey - Trustee
Kitty Kelly Epstein - Trustee

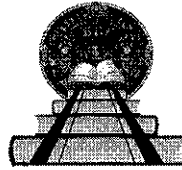

**SPANISH SPEAKING
CITIZENS' FOUNDATION**

Executive Director:
Christopher Nery Martinez

Aztec Run Committee:
Ramon Rodriguez
Jose Arredondo
Mariano Contreras
Ruben Briones
Marin Rodriguez

1470 Fruitvale Avenue · Oakland, CA · 94601-2324 · Info@sscf.org · www.sscf.org · 510-261-7839

January 16, 2024

Parks and Recreation Advisory Commission
Central Reservations Unit
Office of Parks and Recreation
250 Frank H. Ogawa Plaza, Suite 3330
Oakland, CA 94612

Dear Parks and Recreation Advisory Commission:

On behalf of the East Bay Spanish Speaking Citizens' Foundation (SSCF) and our dedicated volunteers who make up the Aztec Run [for Education] Committee, we wish to submit our proposal letter announcing our annual event, the Aztec Run for Education, to be held on Sunday, May 5, 2024, and requesting our ability to collect funds on-site.

Per the Parks and Recreation Advisory Commission Proposal Letter Requirements, please find our responses to the requests for information below:

Brief history of the organization:

The East Bay Spanish Speaking Citizens' Foundation (SSCF) is located in the heart of the vibrant Fruitvale neighborhood. We have been providing services to the community since 1965. We offer programs and services in three areas: 1) immigration and citizenship assistance, 2) educational and workforce development for youth and adults, and 3) information and referral.

Our programs and services continue to be relevant and reflect the ever-changing needs of the Latina/o/e/x community. SSCF's services focus on helping Spanish-speaking youth and immigrants elevate their voice, presence, participation, and power to improve quality of life while celebrating the common cultural heritage of recent and long-term residents.

Overview of event:

The Aztec Run for Education, a 5K run/walk, is a fun-filled, family-friendly event to build relationships, strengthen our social connections, and to celebrate being in community. Our first Aztec Run for Education began in 1983 and we are excited to continue this long tradition.

This year it is scheduled to take place on Sunday, May 5, 2024. As in past years, the 5K run/walk will go once around beautiful Lake Merritt in Oakland, CA. Our supporters will include runners, walkers, volunteers, clients, sponsors, donors and dancers! Participation is open to all ages, all running/walking levels, accessible to those living with disabilities.

Providing Educational Enrichment Services & Promoting Civic Responsibility. Since 1965.

**Exhibit A - Spanish Speaking Citizen's Foundation Proposal Letter
PRAC Item 4B - March 13, 2024**

Request to collect funds:

We request to collect funds on-site. The funds will include on-site registration fees as well as money from the sale of promotional merchandise/swag (ex. t-shirts, caps, drawstring bags, etc.). A breakdown of the amounts include:

- *Registration costs:*
 - *Fees range from \$10-\$55 depending on the age of the participant.*
 - *Please visit <https://aztecrun.itsyourrace.com/> for a complete breakdown of the registration fees based on ages, and to register for the event.*
- *Merchandise sales:*
 - *Range for item prices will be from \$10-\$35, depending on the item.*
 - *For example: Our commemorative post-pandemic 2022 jersey will be sold for \$35 each. Other t-shirts from 2023 and 2024 may be sold for a similar price. Souvenir water bottles with the Aztec Run logo may sell for \$10+.*

Why funds are being collected on-site:

The funds that are collected on-site give community members/supporters the opportunity for same-day registration to participate in the Aztec Run for Education, and/or to buy promotional items to support SSCF's programs and services.

Who will benefit from funds collected:

All funds raised by the Aztec Run for Education support the educational enrichment programs at SSCF which help our youth and community thrive.

Thank you for your time and consideration. Please feel free to contact us should you have any questions or concerns. We look forward to your positive response.

Warm regards,



Christopher N. Martinez
Executive Director, SSCF

On behalf of The Aztec Run Committee

Enclosures:

- Copy of IRS determination letter affirming SSCF's Non-Profit 501c3 status

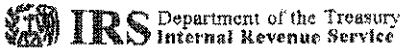

Department of the Treasury
Internal Revenue Service
P.O. Box 2508
Cincinnati OH 45201

In reply refer to: 0752235477
Jan. 28, 2022 LTR 4168C 0
-*8221 000000 00
00018588
BODC: TE

EAST BAY SPANISH SPEAKING CITIZENS
FOUNDATION
% ALICIA CONTRERAS
1470 FRUITVALE AVE
OAKLAND CA 94601-2324

019056

Employer ID number: **-***8221
Form 990 required: Yes

Dear Taxpayer:

We're responding to your request dated Jan. 19, 2022, about your tax-exempt status.

We issued you a determination letter in April 1968, recognizing you as tax-exempt under Internal Revenue Code (IRC) Section 501(c) (3).

We also show you're not a private foundation as defined under IRC Section 509(a) because you're described in IRC Sections 509(a)(1) and 170(b)(1)(A)(vi).

Donors can deduct contributions they make to you as provided in IRC Section 170. You're also qualified to receive tax deductible bequests, legacies, devises, transfers, or gifts under IRC Sections 2055, 2106, and 2522.

In the heading of this letter, we indicated whether you must file an annual information return. If you're required to file a return, you must file one of the following by the 15th day of the 5th month after the end of your annual accounting period:

- Form 990, Return of Organization Exempt From Income Tax
- Form 990EZ, Short Form Return of Organization Exempt From Income Tax
- Form 990-N, Electronic Notice (e-Postcard) for Tax-Exempt Organizations Not Required to File Form 990 or Form 990-EZ
- Form 990-PF, Return of Private Foundation or Section 4947(a)(1) Trust Treated as Private Foundation

According to IRC Section 6033(j), if you don't file a required annual information return or notice for 3 consecutive years, we'll revoke your tax-exempt status on the due date of the 3rd required return or notice.

You can get IRS forms or publications you need from our website at www.irs.gov/forms-pubs or by calling 800-TAX-FORM (800-829-3676).

If you have questions, call 877-829-5500 between 8 a.m. and 5 p.m.,

0752235477
Jan. 28, 2022 LTR 4168C 0
-*8221 000000 00
00018589

EAST BAY SPANISH SPEAKING CITIZENS
FOUNDATION
% ALICIA CONTRERAS
1470 FRUITVALE AVE
OAKLAND CA 94601-2324

local time, Monday through Friday (Alaska and Hawaii follow Pacific time).

Thank you for your cooperation.

Sincerely yours,



Teri M. Johnson
Operations Manager, AM Ops. 3



POST EVENT REPORT

Please complete and return the Post Event Report within 30 days after event date to Oakland Parks and Recreation Central Reservations Unit at 250 Frank H. Ogawa Plaza, 3rd Floor, Suite 3330, Oakland, CA 94612. If the event was held at a Recreation Center site, return the Post Event Report to the Site Supervisor at the Recreation Center.

I. GENERAL INFORMATION

Name of Event: Aztec Run/Walk for Education

Location of Event: Lakeside Park, Knoll behind Boat House

Date/Hours of Event: May 7, 2023 Permit No. 510 261-7839 ↗ ↘

Event Contact Name: Christopher Martinez Phone No. _____

Event Contact Address: 1470 Fruitvale Ave, Oakland 94601

Is this a "first time" event at this location? Yes No If no, when was the event held previously?

May, 2022; May, 2019; May 18, 2018; etc.

1. Were Facility Rental/Set-up fees waived? Yes ~~No~~ Not Applicable

2. Check other permits required for event?

- OPD Special Events Permit Food Handler's Permit Seller's Permit
- Charitable Solicitations Permit Certificate of Insurance Other - Please list

Fire Marshall's sign-off, Temporary food facility health permit.

II. ATTENDANCE/COLLECTION OF FUNDS

1. Total number in attendance: 193

2. Were registration fees, donations or other fees collected on-site? Yes No

3. If yes, how many people registered? All registration & donation off site. Not Applicable
How many people made donations? _____

4. What was the cost for registration? sliding scale by age.

5. How much was collected on site from registration fees? -0-

6. How much was collected on site from donations? -0-

7. How much was collected on site from other fees? -0-

III. VENDOR INFORMATION

List all Vendors who participated at the event. (Attach additional sheets, if necessary):

Were all vendors in compliance per agreement? Yes No

If no, why not? N. A. No vendors at this event.

Name of Vendor(s) (Attach additional sheets if necessary)	Non-Profit or For Profit Orgz'n?	Food (Describe)	Craft (Describe)	Seller's Permit Y/N
/	/	/	/	

IV. COMMENTS

List ways in which the Applicant desires to improve the event, in the future (Attach additional sheets, if necessary): (For example: changes or additional vendors, location, change of hours, etc.)

We will continue to grow the number of participants and event sponsors, otherwise we are pleased with our present format.

List any problems, concerns, or other comments about your satisfaction in the way the event turned out? (Attach additional sheets, if necessary):

To avoid the cost of porta-potty rentals, we will appreciate 2-weeks advance notice that the Boat House toilet will be opened for our use.

Submitted by: Christopher Martinez (Signature) Date: 11/22/2023

Approved by: [Signature] (OPR Staff) Date: 11/2023

Comments: Central Reservations staff will work with Oakland Public Works to ensure the restrooms near the Lake Merritt Sailboat House are open for use.



CITY OF OAKLAND
Oakland Parks, Recreation & Youth Development

TO: Tam Tran, Chair, Parks and Recreation Advisory Commission (PRAC)
FROM: Steve Weiss, AICP, Assistant to the Director, Oakland Public Works (OPW)
DATE: February 29, 2024
SUBJECT: Informational Report: OPW Monthly Performance Update for Measure Q

SUMMARY

This report provides:

1. OPW's routine updates to PRAC regarding the hiring of staff related to Measure Q-funded park maintenance services.
2. Updated performance measures for the delivery of Measure Q-funded services.

BACKGROUND / LEGISLATIVE HISTORY

Measure Q, approved by Oakland voters in March 2020, provides funding for City of Oakland services related to parks maintenance, homelessness services, and water quality, subject to civilian oversight. The Oakland City Council assigned PRAC the oversight role regarding the Measure Q expenditures related to parks maintenance and water quality services. As a component of this oversight function, OPW routinely submits to PRAC updates on hiring of positions related to Measure Q-funded park maintenance services.

Additionally, Measure Q includes service performance requirements. OPW has been working with PRAC to develop a reporting template for measuring and tracking performance of those services. The department's goal is a routine report that is clear, simple, and accessible so that the community understands how their Measure Q tax dollars are being used. This will be an iterative process, and OPW welcomes feedback from PRAC on how the department can continue honing the reporting.

The reporting is meant to:

- 2) Serve as a snapshot in time about where things are at with OPR's tracking and measuring of specific performance metrics that are required in Measure Q.
- 2) Present the metrics and information in the clearest way possible to an average person. When Public Works comes to PRAC meetings, they must be helpful in explaining the content in laypersons' terms. But when Joe Q, ultimately, the "Public" clicks on the link to review the materials on their home computer, ultimately the information must be presented in a way that is easily accessible to all Oakland residents and stakeholders. Striving to improve accuracy with a simple reporting platform is what OPW staff strives to provide.

SUMMARY

Since the last PRAC meeting where Measure Q deliverables were presented, OPW staff has been refining the tracking mechanisms used so all reportable Measure Q data can be validated in an accurate manner. This report and related exhibits and attachments focuses on four areas that OPW is in the process of refining.

1. **Staffing:** Exhibit A Pages 3-4 summarizes hiring by position.
2. **Ballfield Mowing:** Exhibit B Page 5, updates ballfield mowing regularity since July 2023 with additional information regarding “major” parks and equitable ranking.
3. **Trash and Litter:** Exhibit B Page 6, documents litter pickups as a new metric added in Jan 2022. In previous years, litter pickup was not calculated as a separate metric, it was included in the work categorized as Park maintenance.
4. **Restroom Cleaning:** Exhibit B Page 7, OPW has merged data collection from Cityworks Maintenance Management and Permitting Software with an application (app) utilizing cell phones or tablets which document in “real time” where and when maintenance staff is able to report regular visits and condition of the facility. Exhibit B is a draft working sample by gathering accurate real-time information for servicing all Oakland Park restroom facilities that OPW has responsibility for. Staff hopes to provide PRAC with the first monthly progress with this refined format at the next scheduled meeting.

RECOMMENDATION

OPW recommends that PRAC accept this informational report.

Respectfully submitted and prepared by:

/s/ Steven Weiss

Steven Weiss, AICP

Assistant to the Director

Oakland Public Works

Attachments:

Exhibit A – *Measure Q Hiring Progress Tracker, as of 01/10/24*

Exhibit B – *Performance Measures and Service Delivery Charts, as of 01/31/24*

Exhibit A – Measure Q Hiring Progress Tracker, as of 01/10/24 – DRAFT

The table below shows the status of positions funded by Measure Q as of January 10, 2024.

Fund	Classification	#Filled	#Vacant	%Vacant
Measure Q	Administrative Assistant II	1		
Measure Q	Business Analyst II	1		
Measure Q	Capital Imp Proj Coord, Asst	1		
Measure Q	Construction & Maintenance Mechanic	1	1	50.00%
Measure Q	Custodian	3	2	40.00%
Measure Q	Electrician		1	100.00%
Measure Q	Engineer, Assistant I (Office)		1	100.00%
Measure Q	Gardener Crew Leader	23	3	11.54%
Measure Q	Gardener II	30	1	3.23%
Measure Q	Irrigation Repair Specialist	4		
Measure Q	Painter	2		
Measure Q	Park Attendant, PPT	4		
Measure Q	Park Equipment Operator	6	1	14.29%
Measure Q	Park Supervisor I	2	4	66.67%
Measure Q	Park Supervisor II	2		
Measure Q	Tree Trimmer	2	1	33.33%
Measure Q	Tree Worker	1	2	66.67%
Total		83	17	17.00%

PPT = Permanent Part-time (Over 1,950 hours – Civil Service)

Exhibit B – Performance Measures and Service Delivery Charts, as of January 31, 2024 –DRAFT
Measure Q deliverable: Provide dedicated staff at major parks.

Major parks are City-operated community-serving parks, region-serving parks, and resource conservation areas, as defined in the Open Space Conservation & Recreation element of the Oakland General Plan (Section 3(b)(1)(m).

Community-serving parks: Arroyo Viejo, Brookdale, Brookfield, Bushrod, DeFremery, Dimond, Montclair, Mosswood, San Antonio

Region-serving parks: Joaquin Miller (improved areas), Lakeside

Resource conservation areas: Beaconsfield, Claremont Canyon, Dimond Canyon, Garber, Glen Daniel/King Estates, Joaquin Miller (unimproved areas), Leona Heights Open Space

NOTE: Data displayed is baseline data before all Measure Q positions have been filled.

Major Parks: Staff Labor Hours			
FY Facility name and address	FY 23-24		
	Nov	Dec	Jan
Arroyo Viejo Park, 7701 Krause Avenue**	755.00	410.00	630.00
Brookdale Park, 2535 High Street	36.00	126.00	150.00
Brookfield Park, 525 Jones Avenue*		36.00	231.00
Bushrod Park, 569 59th Street	915.00	640.00	116.00
Defremery Park, 1651 Adeline Street**	414.00	240.00	414.00
Dimond Park, 3860 Hanley Road	232.00	312.00	328.00
Joaquin Miller Park, 3300 Joaquin Miller Road	730.00	912.00	438.00
Lakeside Park, 666 Bellevue Avenue	472.00	729.00	760.00
Montclair Park, 6300 Moraga Avenue		30.00	72.00
Mosswood Park, 3612 Webster Street	436.00		
San Antonio Park, 1701 E 19th Street*			48.00

Note that 173.33 hours is equivalent to one full-time staff person per month in the table above. At locations where there are more than 173.33 labor hours recorded at a major park, the number will exceed the 173.33 hours.

Staff at Major Parks			
FY Facility name and address	FY 23-24		
	Nov	Dec	Jan
Arroyo Viejo Park, 7701 Krause Avenue**	4.36	2.37	3.63
Brookdale Park, 2535 High Street	0.21	0.73	0.87
Brookfield Park, 525 Jones Avenue*		0.21	1.33
Bushrod Park, 569 59th Street	5.28	3.69	0.67
Defremery Park, 1651 Adeline Street**	2.39	1.38	2.39
Dimond Park, 3860 Hanley Road	1.34	1.80	1.89
Joaquin Miller Park, 3300 Joaquin Miller Road	4.21	5.26	2.53
Lakeside Park, 666 Bellevue Avenue	2.72	4.21	4.38
Montclair Park, 6300 Moraga Avenue		0.17	0.42
Mosswood Park, 3612 Webster Street	2.52		
San Antonio Park, 1701 E 19th Street*			0.28

Note that the number one is equivalent to one full-time staff person per month in the table above. In instances where hours exceed the equivalent of one full-time staff person for the month, the number will be higher than one.

*These parks are located in high priority neighborhoods as per the DOT Equity Toolkit

** These parks are located in highest priority neighborhoods as per the DOT Equity Toolkit

Here is a link to the DOT Equity Toolkit: <https://www.oaklandca.gov/resources/oakdot-geographic-equity-toolbox>

Exhibit B – Performance Measures and Service Delivery Charts, as of January 31, 2024 – DRAFT

Measure Q deliverable: Mowing City operated sports fields frequently, every other week, or as may be required by the time of year.

Ballfields	Nov	Dec	Jan	FYTD Average	Expectation Met?
Allendale Rec Center Field*	3	1	1	2.3	Meets
Arroyo Viejo-McConnell Field**	3	1	1	2.0	Meets
Arroyo Viejo-Ricky Henderson A's Field**	3	1	1	1.0	Doesn't Meet
Brookdale Rec Center Field*	2	0	2	1.3	Doesn't Meet
Brookfield Rec Center Field*	1	0	0	0.4	Doesn't Meet
Burckhalter Park Field	3	1	1	2.3	Meets
Bushrod- Lower Field	3	1	1	1.6	Doesn't Meet
Bushrod-Upper Field	3	1	1	1.7	Doesn't Meet
Central Reservoir Park Field*	0	1	0	0.6	Doesn't Meet
Concordia Park Field *	1	1	1	0.6	Doesn't Meet
Curt Flood Field*	3	0	1	2.3	Meets
Estuary Park Field	1	0	0	0.1	Doesn't Meet
Franklin Field	2	1	1	2.0	Meets
Garfield Ballfield**	1	1	0	1.3	Doesn't Meet
Golden Gate Rec Center Field	1	1	1	1.7	Doesn't Meet
Greenman Field/Carter Gilmore**	2	1	1	1.9	Doesn't Meet
Joaquin Miller (Robin Perry) Field	1	0	0	0.4	Doesn't Meet
Montclair Rec Center Field	3	1	0	1.3	Doesn't Meet
Oakport Field	2	1	1	1.7	Doesn't Meet
Otis Spunkmeyer Field	2	1	1	1.7	Doesn't Meet
Pinto Park (Joned Field)	3	1	1	2.0	Meets
Raimondi Field	2	0	1	1.3	Doesn't Meet
San Antonio Field**	1	0	0	0.9	Doesn't Meet
Shepherd Canyon Park Field	2	1	0	0.6	Doesn't Meet
Sobrante Park Field	0	0	0	0.1	Doesn't Meet

FYTD = Fiscal Year To Date, which is July 1, 2023 to January 31, 2024 for this report.

*These ballfields are located in high priority neighborhoods as per the DOT Equity Toolkit

** These parks are located in highest priority neighborhoods as per the DOT Equity Toolkit

Here is a link to the DOT Equity Toolkit: <https://www.oaklandca.gov/resources/oakdot-geographic-equity-toolbox>.

Exhibit B – Performance Measures and Service Delivery Charts, as of January 31, 2024 – DRAFT

Measure Q Deliverable: Collecting trash and litter several times per week, including Saturdays and Sundays, from the City’s most used parks, assuring equitable distribution of resources.

Month + Year	# of Hours Picking up Litter	Volume of Litter (cubic yards)
Nov 2023	847	798.00
Dec 2023	759	633.80
Jan 2024	998	1,468.50
Total	2604	2,900.30

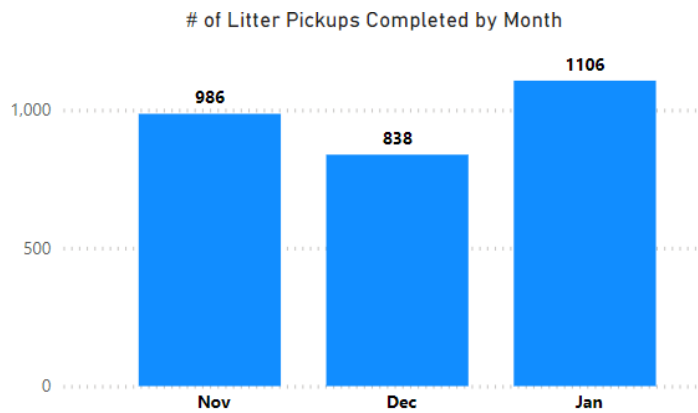

Exhibit B – Performance Measures and Service Delivery Charts, as of January 31, 2024 – DRAFT

Measure Q deliverable: Cleaning Park restrooms more than once per day, especially on weekends.

Below is beta testing data using a new restroom cleaning application to show average daily cleanings by month.

Outdoor Restroom Locations	Status	Target	Nov	Dec	Jan	FYTD
12th St & Lake Merrit Blvd Outdoor Restroom		2	0	0.42	0.13	1.3
Arroyo Viejo Park - McConnell Field Restroom - Outdoor***	Closed	2	0	0	0	1.2
Astro Park / Eastshore Park - Restroom - Outdoor		2	0.77	0.77	0	1.5
Bella Vista Park - Restroom - Outdoor		1	0.2	0.48	0.26	1.4
Brookdale Park - Restroom - Outdoor***		1	0.23	0.39	0.16	1.3
Burckhalter Park - Restroom - Outdoor		2	0.3	0.29	0.19	1.4
Carter Gilmore Park - New Restroom - Outdoor***	Closed	1	0	0	0	1.2
Carter Gilmore Park - Restroom - Outdoor***	Closed	1	0	0	0	1.2
Central Reservoir Recreation Area - Restroom - Outdoor		2	0.17	0.16	0	1.3
Cesar Chavez Park - Restroom - Outdoor***		2	0.2	0.48	0.16	1.3
Chabot Field - Restroom (OUSD property) - Outdoor	Closed	1	0	0	0	1.2
City Stables - Restroom - Outdoor	Closed	1	0	0	0	1.4
Concordia Park - Portland Loo Outdoor Restroom**		2	0	0	0.1	1.2
Davie Tennis Stadium - Restroom - Outdoor		1	0.47	0.19	0.42	1.5
Defremery Park - Restroom - Outdoor***	Closed	0	0	-	0	1.2
Dimond Park - Restroom - Outdoor		2	0.17	0.39	0.1	1.3
Dunsmuir House - Restroom - Outdoor		1	0	0	0	1.4
Estuary Park - Restroom - Outdoor		1	0.37	0.45	0.84	1.6
Golden Gate Park - Restroom (demolished)		1	0	0	0	1.4
Grove Shafter Park - Restroom - Outdoor***		1	0	0	0	1.4
Joaquin Miller - Abbey - Restroom - Outdoor		2	0	0	0	1.4
Joaquin Miller - Fire Circle Restroom - Outdoor		2	0.7	0.19	0	1.7
Joaquin Miller - Redwood Glen Restroom - Outdoor		2	0.6	0.39	0.06	1.6
Joaquin Miller Park - Meadow Restroom - Outdoor		2	0	0.52	0.26	1.4
Joaquin Miller Park - Sequoia Arena Restroom - Outdoor	Closed	1	0	0	0.13	1.4
Lafayette Square - Restroom - Outdoor		1	0	0	0	1.4
Lakeside Park - Nursery Restroom - Outdoor**	Closed	1	0.67	0.65	0.84	1.9
Lakeside Park/RoseGarden - Bandstand Restroom (closed) -		2	0.3	0	0	1.5
Lowell Park - Restroom - Outdoor		2	0.57	0.68	0.94	1.7
Madison/Wilma Chan Park-Outdoor Restroom***		2	0.3	0.29	1.35	1.5
Maxwell Park - Restroom - Outdoor		2	0.2	0.45	0.29	1.6
McCrea Park - - Restroom - Outdoor		1	0.2	0.45	0.26	1.4
Montclair Park - Restroom - Outdoor		2	0.13	0.39	0.13	1.3
Morcom Rose Garden - Field House and Restroom -		2	1.13	0.9	1.16	1.8
Mosswood Park - Theater Building - Restroom - Outdoor		2	0.43	0.65	0.84	1.5
North Oak Sports Center - Caldecott Park - Restroom -	Closed	1	0	0	0	1.2
Oakport Field - Restroom - Outdoor	Closed	1	0.3	0	0	1.5
Officer Willie Wilkins Park - Restroom - Outdoor	Closed	2	0.07	0.03	0.06	1.2
Otis Spunkmeyer Field - Restroom - Outdoor	Closed	1	0	0	0	1.2
Peralta Hacienda - Restroom - Outdoor***		1	0	0	0.03	1.4
Pine Knoll - Restroom - Outdoor restroom		1	0.3	0.29	0.68	1.4
Raimondi Park - Restroom - Outdoor**	Closed	1	0	0	0.13	1.2
Rockridge-Temescal Greenbelt/Frog Park		2	0.63	0.52	0.74	1.5
San Antonio - Restroom - Outdoor**		2	0.23	0.48	0.23	1.4
Shepherd Canyon Park - Restroom - Outdoor		2	0.3	0.39	0.19	1.4
Snow Park - Restroom - Outdoor		2	0.67	0.65	0.58	1.5
Sobrante Park - Field House - Outdoor**		2	0	0	0	1.4
Union Point Restroom - Outdoor		2	0.13	0.52	0.19	1.3
Willow Park - Restroom - Outdoor**		1	0	0	0	1.4
Woodminster Theater - Restroom - Outdoor		1		0.16	0	1.8

FYTD = Fiscal Year To Date, which is July 1, 2023 to January 31, 2024 for this report.

*These restrooms are located in high priority neighborhoods as per the DOT Equity Toolkit

** These restrooms are located in highest priority neighborhoods as per the DOT Equity Toolkit

Here is a link to the DOT Equity Toolkit: <https://www.oaklandca.gov/resources/oakdot-geographic-equity-toolbox>.

CITY OF OAKLAND
Oakland Parks, Recreation & Youth Development



TO: Tram Tran, Vice Chair, Park and Recreation Advisory Commission
FROM: Lisa Beverly, Public Service Representative
DATE: February 29, 2024
SUBJECT: REQUEST FROM JAMAICAN AMERICAN COMMUNITY ORGANIZATION (JACO) TO COLLECT FUNDS ONSITE FOR DONATION OF TICKET SALES, THE SALES OF FOOD AND BEVERAGES AT THEIR ANNUAL JULY 4TH FAMILY DAY, TO BE HOSTED AT JOAQUIN MILLER PARK (BAYWOOD AND PINEWOOD PICNIC SITES) ON THURSDAY, JULY 4, 2024, FROM 7:00AM – 8:00PM.

SUMMARY

Oakland Parks, Recreation & Youth Development received a request from Jamaican American Community Organization (JACO) requesting approval to collect funds onsite for donation of ticket sales, sales of food and beverages at their Annual July 4th Family Day at Joaquin Miller Park (Baywood and Pinewood Area). This event celebrates Jamaican American heritage and culture in America and provides an opportunity for people of Jamaican ancestry, living in America to come together and celebrate both rich cultures. The applicant is aware of the additional permit required. Approval from the Parks and Recreation Advisory Commission is required per O.M.C. section 12.64.080.

FISCAL IMPACT

Jamaican American Community Organization (JACO) is paying all rental fees associated with the event estimated at \$1165.90.

PROJECT / PROGRAM DESCRIPTION

The Annual July 4th Family Day at Joaquin Miller Park is an ongoing tradition in the community. The event serves as a social bridge for the Jamaican, Caribbean, and American Community at large.

JACO, is requesting to collect funds onsite for donation of ticket sales, the sales of food and beverages. The collection of funds are as follows:

- Food Sales: \$2 - \$7
- Beverages: \$1 - \$2

BACKGROUND / LEGISLATIVE HISTORY

The Jamaican American Community Organization was established April 25, 2021, as a non-profit organization. The launch of JACO was in response to the closure of the Jamaican American Association of Northern California (JAANC) which left a void in the Jamaican Community. This event aligns with the organization's mission to promote the national culture of Jamaica in Northern California, to foster a better understanding among Americans with a commitment to non-political and non-sectarian activities, promote diversity and awareness for the respect of cultural difference among

all citizens of Northern California. This event helps JACO to bring people together and foster good will and reminds people of home and beauty of the people and nature.

RECOMMENDATION

Staff recommends that the Park and Recreation Advisory Commission approve the request from Jamaican American Community Organization to collect funds onsite for donation of ticket sales, the sales of food and beverages at their Annual July 4th Family Day at Joaquin Miller Park (Baywood and Pinewood Picnic Sites) on Thursday, July 4, 2024, 7:00am-8:00pm.

Respectfully submitted,

/s/ Lisa Beverly

Prepared by:

Lisa Beverly

Public Service Representative

/s/ Zermaine Thomas

Approved by:

Zermaine Thomas

Special Events Coordinator

Attachments: Exhibit A – Jamaican American Community Organization (JACO) Proposal Letter
Exhibit B – Jamaican American Community Organization (JACO) Non-Profit Certificate
Exhibit C – Jamaican American Community Organization (JACO) Post Report



Executive Board

CEO
Carl Wilkinson

COO
Avemaria Smart

CMO
Shorron Levy

CFO
Clover Graham

02/14/2024

Director at Joaquin Miller Park,
Attention: Parks and Recreation Advisory Commission

JACO (Jamaican American Community Organization) was launched into existence on April 25, 2021. JACO is a 501(C)3 nonprofit organization. Our Federal Tax Identification number is 862009006.

The launch of JACO was in response to the closure of the JAANC (Jamaican American Association of Northern California) which left a void to not having a community organization. JAANC had been using the Joaquin Miller Park for the 4th of July Family Day for decades.

The annual July 4th Family Day at Joaquin Miller Park has been an ongoing tradition in our community. The event serves as a social bridge for the Jamaican, Caribbean, and American Community at large. The amount collected on the event day at the Park is around \$1200.00 to \$1500.00 from past experience and covers just a portion of the expenses to put on the event. The annual July 4th Family Day at Joaquin Miller Park is an expectation from the community, especially the children.

JACO respectfully requests to collect funds at the event. There are no involved Vendors at the July 4th Family Day, and all help is VOLUNTARY. The process used to collect donations is from the sales of tickets. The value of each ticket is \$1.00.

Items to be sold are as follows:

Chicken Meal = 7 tickets = \$7.00

Drink = 2 tickets = \$2.00

Water = 1 ticket = \$1.00

Hot Dogs = 3 tickets = \$3.00

Roast Corn = 2 tickets = \$2.00

The proceeds (funds) collected are to offset the cost of the Park, purchase food items, merchandise for serving food, entertainment, equipment for games, tables, chairs, etc. The community will socially benefit from a successful event.

Thank You,

Carl Wilkinson



Department of the Treasury
Internal Revenue Service
Tax Exempt and Government Entities
P.O. Box 2508
Cincinnati, OH 45201

JAMAICAN AMERICAN COMMUNITY
ORGANIZATION
C/O CLOVER A GRAHAM
11845 BLUSHING CIRCLE
RANCHO CORDOVA, CA 95742

Date:
12/15/2021
Employer ID number:
86-2009006
Person to contact:
Name: Customer Service
ID number: 31954
Telephone: (877) 829-5500
Accounting period ending:
December 31
Public charity status:
509(a)(2)
Form 990 / 990-EZ / 990-N required:
Yes
Effective date of exemption:
January 27, 2021
Contribution deductibility:
Yes
Addendum applies:
No
DLN:
26053666001101

Dear Applicant:

We're pleased to tell you we determined you're exempt from federal income tax under Internal Revenue Code (IRC) Section 501(c)(3). Donors can deduct contributions they make to you under IRC Section 170. You're also qualified to receive tax deductible bequests, devises, transfers or gifts under Section 2055, 2106, or 2522. This letter could help resolve questions on your exempt status. Please keep it for your records.

Organizations exempt under IRC Section 501(c)(3) are further classified as either public charities or private foundations. We determined you're a public charity under the IRC Section listed at the top of this letter.

If we indicated at the top of this letter that you're required to file Form 990/990-EZ/990-N, our records show you're required to file an annual information return (Form 990 or Form 990-EZ) or electronic notice (Form 990-N, the e-Postcard). If you don't file a required return or notice for three consecutive years, your exempt status will be automatically revoked.

If we indicated at the top of this letter that an addendum applies, the enclosed addendum is an integral part of this letter.

For important information about your responsibilities as a tax-exempt organization, go to www.irs.gov/charities. Enter "4221-PC" in the search bar to view Publication 4221-PC, Compliance Guide for 501(c)(3) Public Charities, which describes your recordkeeping, reporting, and disclosure requirements.

Sincerely,

Stephen A. Martin
Director, Exempt Organizations
Rulings and Agreements

Letter 947 (Rev. 2-2020)
Catalog Number 35152P



POST EVENT REPORT

Please complete and return the Post Event Report within 30 days after event date to Oakland Parks and Recreation Central Reservations Unit at 250 Frank H. Ogawa Plaza, 3rd Floor, Suite 3330, Oakland, CA 94612. If the event was held at a Recreation Center site, return the Post Event Report to the Site Supervisor at the Recreation Center.

I. GENERAL INFORMATION

Name of Event: JACO 4th July Family Day Event
 Location of Event: Joaquin Miller Park
 Date/Hours of Event: 7/4/23 7am - 7pm Permit No. _____
 Event Contact Name: Caleth Watson Phone No. 510-610-5897
 Event Contact Address: 2476 Havenscourt Blvd, Oakland 94605

Is this a "first time" event at this location? Yes No If no, when was the event held previously?

Annually for about 17 years excluding Pandemic years

1. Were Facility Rental/Set-up fees waived? Yes No Not Applicable

2. Check other permits required for event?

- OPD Special Events Permit Food Handler's Permit Seller's Permit
 Charitable Solicitations Permit Certificate of Insurance Other - Please list

OPD special event permit

II. ATTENDANCE/COLLECTION OF FUNDS

1. Total number in attendance: ~ 250

2. Were registration fees, donations or other fees collected on-site? Yes No

Not Applicable

3. If yes, how many people registered? NA How many people made donations? ~ 15

4. What was the cost for registration? 0

5. How much was collected on site from registration fees? 0

6. How much was collected on site from donations? \$ 203.00

7. How much was collected on site from other fees? _____

↳ ① Food = ~~\$1718~~ [~] \$ 2,418.⁰⁰
 ② Memberships = \$ 160.⁰⁰

III. VENDOR INFORMATION

No Vendors

List all Vendors who participated at the event. (Attach additional sheets, if necessary):

Were all vendors in compliance per agreement? Yes No

If no, why not?

Name of Vendor(s) (Attach additional sheets if necessary)	Non-Profit or For Profit Orgz'n?	Food (Describe)	Craft (Describe)	Seller's Permit Y/N

IV. COMMENTS

List ways in which the Applicant desires to improve the event, in the future (Attach additional sheets, if necessary): (For example: changes or additional vendors, location, change of hours, etc.)

No Vendors

List any problems, concerns, or other comments about your satisfaction in the way the event turned out? (Attach additional sheets, if necessary):

- ① Bath Room Facilities could be better
- ② Not enough garbage receptacle boxes
- ③ Garbage Bins (green metal) had contents and stunk

Submitted by: Carl A. Wilkinson Date: 7/21/2023

Approved by: [Signature] Date: 3/1/24

Comments: OPRD Staff will contact OPW staff to ensure the restrooms are clear.

- ② Additional trash boxes can be purchased through OPW
- ③ Waste management picks up trash 3 times a week at that location.



CITY OF OAKLAND
Oakland Parks, Recreation & Youth Development

TO: Tam Tran, Chair, Parks and Recreation Advisory Commission
FROM: Tanya Nicholson, Public Service Representative, Central Reservations
DATE: January 23, 2024
SUBJECT: REQUEST FROM THE KINGS DELECTABLES FOR APPROVAL TO HAVE ONSITE VENDORS SALES OF FOODS, BEVERAGES AND MERCHADISE AT THE STOP THE VIOLENCE RAP BATTLE TO BE HELD AT LAKE MERRITT BLVD. AMPHITHEATER, SATURDAY, JULY 6, 2024, at 11:00AM-5:30PM

SUMMARY

Oakland Parks, Recreation & Youth Development received a request from Tanisha Wilson owner of Kings Delectables, an Oakland based catering business established in 2016. Tanisha Wilson is requesting approval for vendors sales of foods, beverages, and merchandise at the Stop the Violence Rap Battle at Lake Merritt Blvd. Amphitheater on Saturday, July 6, 2024, 11:00am-5:30pm. Applicant is aware of the additional permits required. Approval from the Parks and Recreation Advisory Commission is required per O.M.C. section 12.64.080.

FISCAL IMPACT

There is a positive fiscal impact Kings Delectables will pay all fees associated with this event which is estimated at a total of \$975.90.

PROJECT / PROGRAM DESCRIPTION

Kings Delectables is hosting a one-day Stop the Violence Rap Battle and promoting local businesses that will showcase and sale their foods and self-made wares and merchandise for no more that \$20. The Stop the Violence Rap Battle is a celebration of Oakland's electric art culture and rich hip-hop history. This FREE event is open to the public, will promote non-violence through its message of stop the violence. The goal is to connect with creative individuals, promote entrepreneurship throughout Oakland, provide quality services and an unforgettable experience to Oakland residents and tourist. The overall objective of the event is to showcase local talent and build a stronger community.

The estimated attendance is 200.

BACKGROUND / LEGISLATIVE HISTORY

Kings Delectables is an Oakland based catering business. Established in 2016, noticed that many of Oakland’s favorite restaurants and businesses were leaving the area or closing. They began catering and participating in farmers markets and local events. Along the way, they met other business owners who also embrace the art of cooking and arts of all kinds.

RECOMMENDATION

Staff recommends that the Parks and Recreation Advisory Commission approve the request from Kings Delectables for vendors sales of foods, beverages, and merchandise onsite at the Stop the Violence Rap Battle to be held at Lake Merritt Blvd. Amphitheater on Saturday, July 6, 2024, at 11:00am-5:0pm.

Respectfully submitted,

/s/Tanya Nicholson

Prepared by:

Tanya Nicholson

Public Service Representative

/s/Zermaine Thomas

Approved by:

Zermaine Thomas

Special Event Coordinator

Attachments: Exhibit A – Kings Delectables proposal letter



KINGS DELECTABLES

1/12/2024

Parks and Recreation Advisory Commission
250 Frank H. Ogawa Plaza Suite 3330, Oakland, California 94612

Dear Parks and Recreation Advisory Commission,

On behalf of Kings Delectables please accept this Proposal Letter as part of our application for the use of Lake Merritt, Amphitheater on July 6, 2024, from 9:00 am- 7:30 pm for our Stop the Violence Rap Battle.

Kings Delectables is an Oakland-based catering business. When we started operation in 2016, we noticed that all our favorite restaurants and businesses were leaving the area or closing. As a result of the "great flight" the neighborhood looked isolated and neglected. It seemed that the absence of business resulted in an increase of crime. Furthermore, there were fewer quality restaurants left in our area. We began catering and participating in farmers markets & local events. Along the way, we have met others who embrace the art of cooking and arts of all kinds. From painting to gardening to photography and music, we found that it all goes hand in hand.

Stop the Violence Rap Battle is a celebration of Oakland's eclectic art culture and rich hip-hop history. This event is intended to promote and support artists of all genre's and engage with the community through art and music. This event will promote non-violence through its message of stop the violence. It is free to the public to promote community engagement, closer community connections and a stronger sense of Oakland pride. Our goal is to connect with creative people, promote entrepreneurship throughout Oakland, provide quality services and an unforgettable experience to Oakland residents and tourists.

Kings Delectables has partnered with the City of Oakland's Activate Oakland Team, Youth Spirit Artworks and more, to bring this vision into fruition. We will showcase key-note non-violence and mental health speakers, celebrity guests, performances by local artists, vendors from Oakland-based businesses and a censored freestyle competition (similar in premise to Wild n' Out or Whose Line is it Anyway?). We are hoping to decrease crime and create a positive experience.

Lake Merritt Amphitheater is the perfect location for this event because of where it sits, its visuals, construction and size. Since this is our first year hosting this event, we want to start small so vendor space is limited. We do not yet know how much money our vendors will earn from selling their products. We are still in search of vendors. So far the vendors who will participate are young artists from Youth Spirit Artworks- they have merchandise which consists of paintings, knitting/crochet garments and jewelery, Go nutz for the people (a candy company) and Kings Delectables (food). I am hoping to have 3 food vendors and 5 merchandise vendors. However, because this is a family friendly event, we ask that sellers keep all items within \$0.00 - \$20.00 price range per item. We will not allow single items to be sold on-site for more than \$20.00.

Oakland can be a great place to do business. We are hoping that artists and Oakland-based businesses can gain monetary compensation and new customers by participating in this event and selling their products on-site.

Thank you in advance for your support in ensuring that Stop the Violence Rap Battle is successful.

Sincerely,

Tanisha Wilson



Exhibit A - Kings Delectables Proposal Letter
PRAC Item 6B - March 13, 2024



**CITY OF OAKLAND
Oakland Parks, Recreation & Youth Development**

TO: Tam Tran, Chair, Parks & Recreation Advisory Commission
FROM: Zemaine Thomas, Special Event Coordinator
DATE: January 31, 2024
SUBJECT: REQUEST FROM OAKLAND REBELS YOUTH BASKETBALL CLUB TO COLLECT ONSITE DONATIONS, TICKET SALES AT DOOR, SALES OF BEVERAGES (ALCOHOL AND NON-ALCOHOL), RAFFLE TICKETS AND HOST SILENT AND LIVE AUCTION AT THEIR CRAB FEED FUNDRAISER TO BE HOSTED AT LAKESIDE PARK GARDEN CENTER ON SATURDAY MARCH 30, 2024, FROM 4:00PM-9:00PM.

SUMMARY

Oakland Parks, Recreation and Youth Development received a request from Oakland Rebels Youth Basketball Club, a non-profit organization, founded in 1987, which helps kids develop both academic and social skills, as well as their basketball skills. Their emphasis is essentially the participants academic performance requires the participants to maintain a high GPA to participate in their athletic program. They provide their student athletes with services such as academic tutors and mentors in both school and life. The Oakland Rebels Youth Basketball Club is requesting to collect ticket sales at the door, collection of onsite donations, sales of alcohol and non-alcohol beverages and to host a silent/live auction at their Crab Feed fundraiser to be held at Lakeside Park Garden Center on March 30, 2024. The event organizer is aware of the additional permits required. Approval from the Parks and Recreation Advisory Commission is required per O.M.C. section 12.64.080.

FISCAL IMPACT

There is a positive fiscal impact Oakland Rebels Youth Basketball Club is paying all the rental fees associated with the event estimated at \$880.40.

PROJECT / PROGRAM DESCRIPTION

This event is an all-you-can-eat crab feed, that will provide 3-6 pounds of Dungeness Crab per person. There will be live entertainment, sales of raffle tickets, silent and live auctions. Oakland Rebels Youth Basketball parents, guardians, and staff members are invited to join this event. There will be presales of tickets and day of event tickets sold at the door along with food, drinks, and entertainment.

BACKGROUND / LEGISLATIVE HISTORY

Oakland Rebels Youth Basketball Club, a non-profit organization, founded in 1987, which helps kids develop both academic and social skills, as well as their basketball skills.

RECOMMENDATION

Staff recommends that the Parks and Recreation Advisory Commission approve the request from Oakland Rebels Youth Basketball Club to collect ticket sales at the door, collection of onsite donations, sales of alcohol and non-alcohol beverages and to host a silent/live auction at their Crab Feed fundraiser to be held at Lakeside Park Garden Center on March 30, 2024, from 4:00pm-9:00pm.

Respectfully submitted,

/s/ Zermaine Thomas

Prepared by:

Zermaine Thomas

Special Events Coordinator

/s/ Harith Aleem

Approved by:

Harith Aleem

Interim Assistant Director

Attachments: Exhibit A – Oakland Rebels Youth Basketball Proposal Letter
Exhibit B – Oakland Rebels Youth Basketball Non-Profit Certificate (501c3)



January 30, 2024

Parks and Recreation Advisory Commission
250 Frank H. Ogawa Plaza, Suite 3330
Oakland, CA 94610

Dear Parks and Recreation Advisory Commission,

On behalf of the Oakland Rebels Youth Basketball please accept this proposal letter requesting approval to collect entry fees at door (although most of the ticket are pre-sold), sales of beverages (alcohol and non-alcohol), donation, sales of raffle tickets, silent & live auction. The monies collected will off set the cost of expenses, athletic scholarships, and student travel expenses.

The Oakland Rebels Youth Basketball Club is a non-profit organization, founded in 1987 to help kids develop both academic and social skills, as well as their basketball skills. They emphasize the "Student" in their organization. Their emphasis is essentially the participants academic performance requires the kids to maintain a high GPA to participate in our athletic program. They provide their student athletes with services such as academic tutors and mentors in both school and life.

The Oakland Rebels is hosting an all-you-can-eat crab feed, that will provide 3-6 pounds of Dungeness Crab per person. There will be live entertainment, sales of raffle tickets, silent and live auctions.

- Crab Feed Ticket: \$75
- Donations: Open
- Raffle Ticket: \$2 per ticket
- Beverages: \$2 - \$10
- Auction Items: \$20 - \$500

Thank you taking the time to review this proposal, I look forward to your approval and continuing to work with OPRYD Staff.

Thank you,



Melvin Landry, Founder/President

Oakland Rebels Youth Basketball

2321 107th Avenue

Oakland, CA 9403

Oaktown Rebels - Welcome to the AAU 2024!

1 message

Nikki Clarke <nclarke@aausports.org>
To: "oaklandrebelsbasketball@gmail.com" <oaklandrebelsbasketball@gmail.com>

Fri, Jan 26, 2024 at 5:19 PM



Congratulations Oaktown Rebels!

Oaktown Rebels, information will be sent to the IRS to be added as subordinate 501(c)(3) organization under the AAU's group exemption for the fiscal year ending on August 31, 2024.

Organizations recognized by the IRS as an Affiliated Organization 501(c)(3), under the AAU's group exemption must understand the responsibilities attached to organizations receiving that status.

Please click on the link for the Welcome Package and review the information. We strongly recommend that you keep a print out for your records. Please allow 7-10 days to receive your determination letter in the mail.

Our finance department is always available to assist you. We have forms available for a variety of requests if you need a verification of the level 3 club. To make any changes to your club, please email nclarke@aausports.org. Due to the high volume of calls, we recommend that these requests are sent by email.

Please click on the following link for the Welcome packet: <https://image.aausports.org/ClubLevel3/L3ClubWelcomePackage.pdf> read the Welcome Packet carefully and if you have any questions or need further assistance, please feel free to contact our finance department.

Sincerely,

Nakedria Clarke

Nakedria Clarke

Amateur Athletic Union of the United States, Inc.
Club Level 3 Support
407-934-7200
407-827-0987 (fax)
nclarke@aausports.org

Confidentiality Notice: This e-mail communication and any attachments may contain confidential and privileged information for the use of the designated recipients named above. If you are not the intended recipient, you are hereby notified that you have received this communication in error and that any review, disclosure, dissemination, distribution or copying of it or its contents is prohibited. If you have received this communication in error, please notify me immediately by replying to this message and deleting it from your computer.

L3Club Welcome Package with Forms.pdf
593K

CITY OF OAKLAND
Oakland Parks, Recreation & Youth Development

TO: Tam Tran, Chair, Parks and Recreation Advisory Commission
FROM: Frederick L. Morris III, OPRYD
DATE: February 27, 2024
SUBJECT: INFORMATIONAL REPORT REGARDING THE OAKLAND BALLERS' PROPOSED IMPROVEMENTS TO AND USE OF THE RAIMONDI PARK BASEBALL FIELD

SUMMARY

The Oakland Ballers (“Oakland Bs” or “Ballers” or “Bs”) intend to use the Baseball Field (the “Field”) at West Oakland’s City-owned, OPRYD-operated Raimondi Park (the “Park”) for their “home” field during their inaugural 2024 Pioneer League baseball season. Subject to necessary permitting requirements and City Council approval, the City intends on entering into a license agreement with the Ballers, allowing them use of the Field for an initial 1-year period at below market rate in consideration of improvements and upgrades to the Raimondi Baseball Field valued at \$1.6 million. The improvements proposed by the Ballers include the following:

- Ground improvements: re-sodding the field and repairing the irrigation system to improve field drainage;
- Technology upgrades: upgrading the existing scoreboard to a video scoreboard with recording and sound capabilities; and
- Equipment upgrades: adding padding to the outfield fence; replacing foul poles; repairing the existing dugout and bullpen; repairing or replacing fencing and netting; upgrading the backstop and outfield warning track; improving the lighting.

In addition to providing the up-front improvements necessary to render the field usable for professional baseball games, the Ballers will provide day-of-game maintenance and upkeep throughout the 2024 season, including trash pick-up and removal, mowing, and associated grounds maintenance. The B’s look forward to hosting open clinics, games, and events for baseball and softball teams from local schools, sports leagues, and community groups.

The Ballers’ initial home game at Raimondi Field is scheduled for June 4, 2024. The Field is currently unusable for professional baseball and specialty upgrades to bring the field up to serviceable condition, such as re-sodding the field and upgrading the scoreboard, must begin as soon as possible. Especially urgent is the re-sodding component, as a newly-sodded field needs time to “cure”. Presented with this ambitious schedule, the City anticipates entering into a Right of Entry Agreement with the Oakland Ballers, allowing repair and maintenance, such as re-sodding of the field and irrigation repair, to expeditiously begin on the ballfield. A subsequent ordinance will be brought to the City Council authorizing a below market license for a 1-year term authorizing further improvements to the ballfield, such as signage replacement and modular structures for a dugout. The City anticipates returning to PRAC next month for review of minor

conditional use permit(s) that may be required for the more substantial field upgrades and/or improvements.

FISCAL IMPACT

No fiscal impacts are included in this informational report. Fiscal impacts will be addressed in the upcoming City Council report.

PROJECT / PROGRAM DESCRIPTION

The Ballers intend to use Raimondi Park at 1800 Wood Street in West Oakland as their home field and aim to host their first home baseball game on June 4, 2024. The Bs and the City are currently navigating the agreements, land use and community engagement steps required to facilitate this. During the January 2024 meeting, PRAC approved the Bs request to collect admission fees and allow food vendors on site, subject to Oakland Municipal Code section 12.64.080; the Ballers have stated their intent to invite local businesses to vend during game days and will be required to obtain any other licenses or permits required by law for food or alcohol sales. Multiple City departments are working in concert with OPRYD to draft and execute the appropriate real estate agreements and corresponding reports and legislation, including Oakland Public Works, Real Estate, the City Attorney's Office, Planning, Parks & Trees, Economic and Workforce Development. The City is determining whether additional agreements (i.e., parking permits) in addition to a license will be required based on the proposed terms of the Bs uses of the field and surrounding property. The Ballers are in active discussions with BART, AC Transit and Bike East Bay, the Department of Transportation, and the Friends of Raimondi Park, among others.

The Oakland Ballers improvements to the Raimondi Baseball Field will be received by the City in the form of a consideration for a license of the property. In this proposed project, the Bs may donate over \$1.6 million in upgrades and improvements to the baseball field. Their proposed enhancements include:

- Ground improvements: re-sodding the field; adding an irrigation system and improving field drainage;
- Technology upgrades: installing a large video scoreboard with recording and sound capabilities; and
- Equipment upgrades: adding padding to the outfield fence; replacing foul poles; repairing the existing dugout and bullpen; repairing or replacing fencing and netting; installing a new backstop; adding an outfield warning track upgrade.

The Bureau of Planning is completing a review process based on the Basic Application for Development Review (BADR) submitted by the Ballers, which will determine the extent to which California Environmental Quality Act (CEQA) analyses are required and permitting is needed. Much of the proposed work consists of repairs and maintenance to existing equipment and applications and may be done without conditional use permits. The City will provide a Right-of-Entry agreement to the Ballers that will allow them to begin work on these repairs and maintenance prior to the license execution.

The City is also engaging in ongoing meetings with the Bs regarding community engagement and feedback, parking and public transportation plans. Our next steps include but are not limited to work with the following departments:

- Planning Bureau: creating a project schedule; determining the property's zoning and General Plan designation; classifying ballpark use and ensuring such use is permitted under zoning and general plan designations; determining what entitlements, if any, are required; completing appropriate CEQA analysis based on a project description;
- City Attorney's Office: advising on legislation; providing guidance on applicable agreements necessary for Ballers' use of the field;
- City Council: will ultimately need to approve acceptance of the ordinance allowing the City Administrator to enter into a license agreement with the Ballers.

BACKGROUND / LEGISLATIVE HISTORY

The Park. Raimondi Park was named for Oakland Oaks player Ernie Raimondi. Baseball Hall of Fame outfielder Frank Robinson, National League All-Star center fielder Vada Pinson, and activist and Gold Glove winning center fielder Curt Flood are among the legendary athletes who played on this field as McClymonds High School students. Situated in West Oakland, the Park is in a historically underserved neighborhood and up until recently abutted the Woods Street homeless encampment. More than a decade ago, Raimondi Park was identified as an existing Oakland park in need of renovation and rehabilitation under the City's Fiscal Year 2003-2005 Capital Improvement Program budget. An overall concept plan was developed in 2003 and 2004 by the Oakland Parks and Recreation Foundation (OPRF, formerly Friends of Parks and Recreation), with input from the community and the City. The overall estimated cost for the entire project at the time was approximately \$7.2 million. Due to a widespread economic downturn, and lack of adequate funds to complete the entire park restoration at one time, a two-phase plan was developed. After Council approved the capital improvements in 2007, Phase 1 commenced and was completed in September 2008.

As a result of significant budget cuts, OPRYD initiated creative avenues to increase revenues for the capital improvement needs in Oakland's parks. By partnering with its users, community non-profits and businesses, OPRYD has been able to better sustain its parks and sports fields to ensure safe and community-oriented environments. In this vein, the proposed real estate license would authorize the City to receive a gift of significant improvements to Raimondi Park; allow a professional league baseball team to utilize the park for home games; enable Oakland youth teams to practice and play on a greatly improved field; and provide year-round benefits to the Oakland community at large.

The Team. Cofounded by Bryan Carmel and Paul Freedman as the first West Coast franchise of the historic Pioneer Baseball League, the Oakland B's formed in 2023 with the intent of building a team that honors the legacy of Oakland's past great players and that values uniting Oaklanders through the power of community sports and teamsmanship. The Ballers aim to host their first home baseball game on June 4, 2024. The adoption of Raimondi Park by the Oakland Ballers baseball team will provide West Oakland with an infusion of excitement, community spirit, financial benefit, and neighborhood improvements.

The Ballers community-centered approach of partnering with the City of Oakland is evident in

their proposal to rejuvenate Raimondi Park for their home, creating a safer environment and improved baseball field where all Oaklanders may come and play on “The Field of Dreams.” While the Oakland Ballers intend to use Raimondi Park as their home field, the upgrades and improvements to the Raimondi Baseball Field will benefit the West Oakland community whether or not Raimondi Field becomes the Ballers’ permanent home. The proposed improvements will provide a high-quality and safe field for local baseball teams to play on, including the Oakland Unified School District championship baseball team and local Little League teams. Upgraded facilities could serve to entice Little League Baseball to hold State and World Series championships in Oakland. The upgraded scoreboard will also allow for non-sport activations of the park including neighborhood movie nights. Park improvements in this underserved neighborhood will contribute to community pride, provide youth with a safe and modernized facility, make Oakland an attractive destination for athletic excellence, and offer the possibility for teams to represent Oakland, in Oakland, on a global stage.

Respectfully submitted,

/s/ Frederick L. Morris III
Frederick L. Morris III
Sports Coordinator

Prepared by:
Felicia Gotthelf
Management Assistant

/s/ Myka N. Hammock
Approved by:
Myka N. Hammock
Sports Supervisor

Attachments:

Exhibit A – Oakland Bs Support letter
Exhibit B – Season One Temporary Improvements and Project Costs
Exhibit C – Raimondi Field Baseline Schedule
Exhibit D – Scoreboard sample



Oakland Ballers Baseball

Oakland Parks and Recreation Advisory Commission
% Office of Parks and Recreation and Youth Development
250 Frank H. Ogawa Plaza, Suite
3330 Oakland CA, 94612

Dear Oakland Parks and Recreation, Advisory Commission:

Oakland's new professional baseball team, the Oakland Ballers, co-founded by Bryan Carmel and myself launched on November 28, 2023, with community members and elected officials from the East Bay including Mayor Sheng Thao (see attached press release) by our side. The B's mission is to build a team committed to honoring baseball's deep roots and legacy in the East Bay. We refuse to let the departure of the A's be the final chapter in Oakland's baseball legacy. Baseball is community building, and the games will bring Oaklanders together. The B's are the first West Coast franchise of the historic Pioneer Baseball League, an independent MLB Partner League founded in 1939. The B's want to invest in and play at the historical Ernie Raimondi Park in West Oakland will host 48 home games and will make significant investments in the park's infrastructure.

We appreciate your time and consideration in this partnership and hope to see you guys at the field.

In community,

A handwritten signature in black ink, appearing to read "Paul Freedman".

Paul Freedman, CEO
Oakland Ballers Baseball
248 3rd St.
Unit #5036
Oakland, CA. 94607

EXHIBIT B
Season One Temporary Improvements and Project Costs

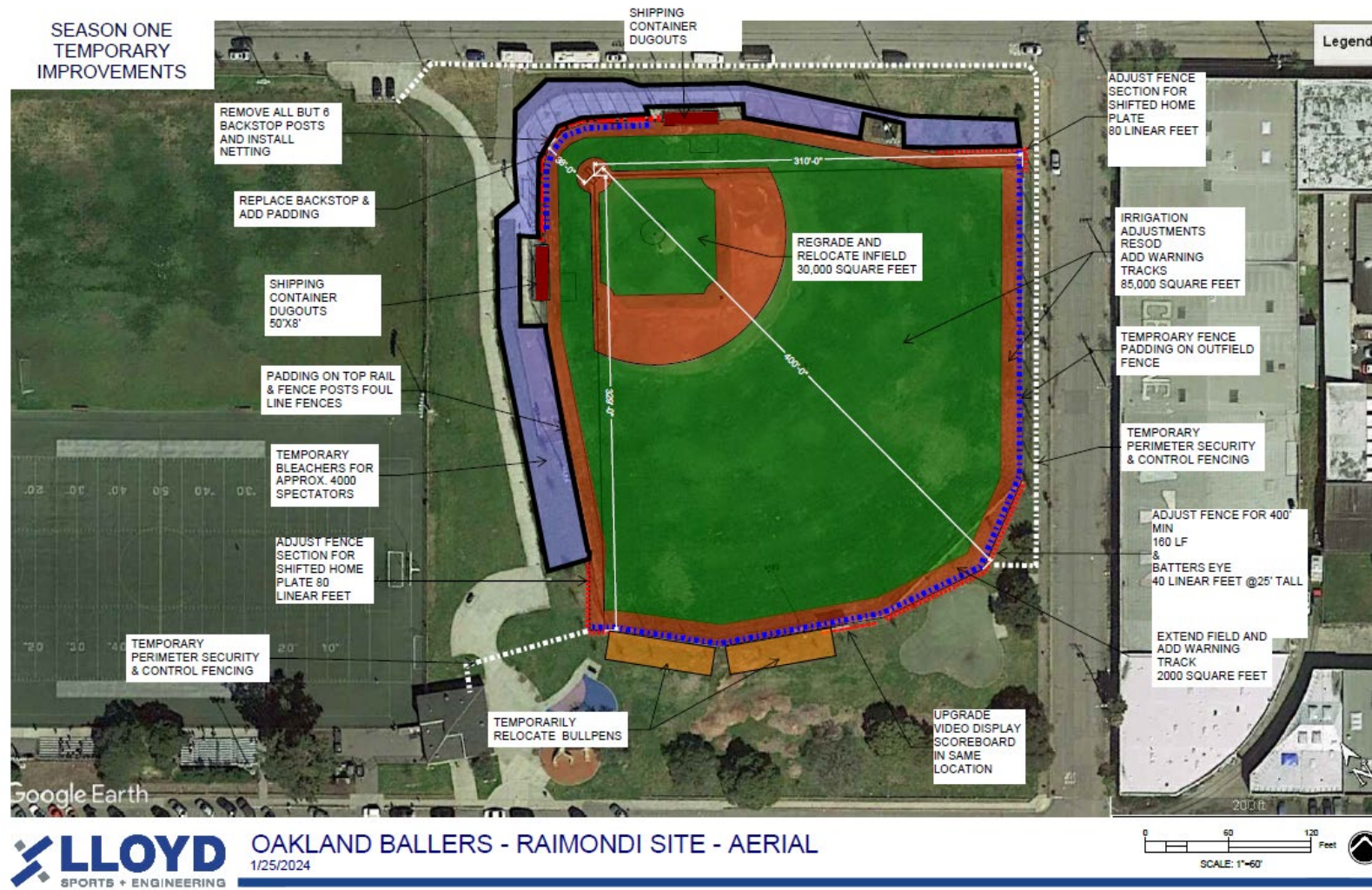

Season One Cost Opinion Items - 1/25/2024 Sports & Civil Items - Lloyd Engineering

Playing Field	Relocate & regrade & finish infield fines and irrigation & sod	30,000 SF	\$5.00	\$150,000.00
	Irrigation adjustments and resod Outfield w/ Warning Track	85,000 SF	\$3.50	\$297,500.00
	Field drainage improvements	1 AL	\$25,000.00	\$25,000.00
	Fence Improvements 8' Fence Sections	360 SF	\$135.00	\$48,600.00
Others	Dugouts Improvements	2 EA	\$87,500.00	\$175,000.00
	Bullpen repairs and adjustments w/ in field fines	3,800 SF	\$42.00	\$159,600.00
	Batter's Eye 30' tall	1 LS	\$500.00	\$500.00
	Backstop replacement & padding	120 LF	\$465.00	\$55,800.00
	Backstop netting replacement	1 AL	\$30,000.00	\$30,000.00
	Outfield fencing padding	600 LF	\$295.00	\$177,000.00
	Foul Line Rail & Post Padding	550 LF	\$135.00	\$74,250.00
	Sound system on existing netting posts allowance	1 AL	\$80,000.00	\$80,000.00
	Electrical - Sound system - (Replace Existing Equipment)	1 AL	\$150,000.00	\$150,000.00
	Temp Lighting	1 AL	\$50,000.00	\$50,000.00
	Digital Scoreboard and installation (Replace Existing Equipment)	1	\$150,000.00	\$150,000.00
		SUB		\$1,623,250.00

*This opinion of probable costs is based on costs observed on recently constructed sports field projects. This opinion of probable costs is for budgetary purposes and not an engineer's estimate or guarantee of construction



Project: 5035 - Baseline Schedule Date: Thu 3/7/24

Task: [Blue Bar] Split: [Dotted Line] Progress: [Grey Bar] Milestone: [Diamond]

Summary: [Arrow] Project Summary: [Arrow] External Tasks: [Arrow] External Milestone: [Diamond] Deadline: [Down Arrow]

EXHIBIT D
Example Scoreboard



Option 2

Turn-key Highlights

16mm Option

31.5' x 16'

600 x 300 Resolution

180,000 total pixels

Frame and installation

Estimated electrical: 36k Watts

3% Spare parts

Customer training

Budget

\$225,000*

**Pending Engineer Review and Stamped Drawings*

Copyright © 2024 Unified Board Operations, LLC dba Visua. Drawing is for conceptual purposes only and may not be to exact scale or resolution. The details and design are confidential and proprietary.

 <p>Visua 3120 South Ave Suite 126 La Crosse, WI 54601 Toll Free: (866) 847-8228 Sales: Sales@Visua.us</p>	SIGNATURE OF APPROVAL:	DATE:	PROJECT TITLE:	DRAWIN BY: P. Cimoch	VER.
	SIGNATURE OF APPROVAL:	DATE:	Oakland Ballers	DATE: 02/02/2024	2
				DWG NO. D2084	

CITY OF OAKLAND
Oakland Parks, Recreation & Youth Development

TO: Tam Tran, Chair, Parks and Recreation Advisory Commission
FROM: Joe DeVries, City Administrator’s Office
DATE: March 1, 2024
SUBJECT: REQUEST FOR THE PARKS AND RECREATION ADVISORY COMMISSION TO RECEIVE AN UPDATE ON CITY ACTION AT PINE KNOLL PARK AND MAKE A RECOMMENDATION IN SUPPORT OF A CONDITIONAL USE PERMIT TO REPLACE THE NONFUNCTIONAL BATHROOM IN THE PARK WITH A NEW PORTLAND LOO ON LAKESHORE AVENUE THAT IS ADA COMPLIANT AND TO INSTALL A VEHICLE DETERENT BARRIER AT THE PERIMETER OF THE PARK TO RESTORE PUBLIC ACCESS IN A SAFE AND EQUITABLE MANNER.

SUMMARY

In November 2023 the Lake Merritt Working Group, decided to temporarily close Pine Knoll Park due to increased and constant criminal activity in the form of reckless driving that consisted of motorcycle and all-terrain vehicle (ATV) “sideshows” that were damaging the park landscaping, and making the park inaccessible to most other users. By closing the park in November, the City took advantage of the winter season to restore the damaged turf and conduct community engagement around new design features that would prevent this type of activity in the future to allow families to again enjoy the park in peace.

During the deliberative process, Public Works Facilities Staff reported that the bathrooms at Pine Knoll Park were in disrepair and could not be restored and made ADA accessible. Staff also identified that a new Portland Loo, which is a modern more maintainable and ADA compliant bathroom, was available and could be installed on Lakeshore Avenue across from the park that would be more accessible to all Lake Merritt visitors.

Led by Council President Bas, staff met with neighbors at the park in January 2024 to hear about their observations and to share conceptual designs that could be implemented in the park. That engagement has been ongoing and the City now has viable proposals for the PRAC to consider. The City is required to seek a Conditional Use Permit to perform any improvements at the park and is seeking a recommendation from the PRAC to replace the existing bathroom with a Portland Loo and install a new vehicle deterrent barrier.

FISCAL IMPACT

Total costs for this project are undetermined until a recommendation is received to help determine what type of installation will occur. However, some costs are known already:
The Portland Loo costs included ~\$275,000 to manufacture and ~\$100,000 to install for a total of approximately \$375K with the funding being a combination of General Fund and Measure Q dollars. The quote the City received for fencing was \$40,000 but staff are still awaiting a quote on the

wooden guardrails and pricing a chicane design. Those costs can be funded with Lake Merritt Parking Management revenues that were allocated for park improvements by the City Council in the 2023-24 budget. The demolition and any irrigation modifications are incomplete and therefore the total cost is unknown but they will be funded by Public Works O&M sources.

BACKGROUND / LEGISLATIVE HISTORY

Community Concerns:

In the final two months of 2022, OPD data shows that Pine Knoll Park received 25 individual calls for service to the 911 Emergency Communications Center, 9 of which were for reckless driving, sideshows, or vehicle disturbance. In the first ten months of 2023 that number grew dramatically to over 92 incidents of either reckless driving or sideshow activity at the park. In total, in the one year before the park was closed, there were 261 calls for service with 101 for reckless driving or sideshow activity. Additionally, there were 7 incidents of someone brandishing a weapon and another 7 incidents of disturbing the peace. This data aligns with ongoing communication received by the City Council Office and City Administrator's Office from the surrounding community about ATV/Motorcycle Sideshows that included threats to park goers on numerous occasions including the display of guns. These incidents caused a significant decline in people using the park due to these ongoing safety concerns. See **Attachment A** for a full list of calls for service to the location.

Neighbors have also noted activity occurring behind the non-functional bathrooms that also caused safety concerns. Occasional homeless encampments would locate in the area and start fires dangerously close to the residential buildings that abut the park. Due to the fact that the bathrooms cannot be made ADA accessible and are in disrepair, the City had determined that Measure Q dollars could be used to demolish them and replace them with an ADA compliant Portland Loo on Lakeshore that would be more accessible to a broader segment of the public that frequents the lake.

Developing Solutions:

On two occasions in the past two years, staff from the City's Neighborhood Services Division who are trained in security surveys and Crime Prevention Through Environmental Design (CPTED) met with neighbors and discussed possible options to address these ongoing issues. Both a perimeter protection that would prevent vehicular access and a fence to block the area behind the bathrooms were discussed. The fencing idea behind the bathroom was met with mixed support as many neighbors were concerned the fence would be unmanaged and breached and that if this were to happen it would be even more difficult to have the area cleared. Although staff sought quotes from contractors, no action was taken.

On January 29th Council President Bas convened a community meeting with City staff and over 25 neighbors to share ideas and hear people's concerns. Staff presented two perimeter options: using a four-foot-high black, vinyl coated chain link fence for the perimeter or utilize logs provided by the City's Tree Division. In both scenarios, a "chicane" would be installed at each walkway into the park to prevent vehicular access while preserving ADA access. A chicane is an obstruction that requires park goers to turn right and left in a short distance to navigate a pathway in a manner that allows a wheelchair or stroller to make the turn but not a larger motorized vehicle such as a motorcycle or ATV (see photos in **Attachment B**).

Neighbors expressed support for installing logs and dislike of the chain link fence for two reasons; aesthetics of chain-link at Lake Merritt not being aligned with the nature of the area and a concern that the fence would be easily vandalized, allowing the negative activity to reoccur quickly.

Since that meeting, staff have further reviewed the interest in logs and determined that they are not feasible for this location for the following reasons:

- Although logs have been deployed successfully in wooded areas of the City such as Skyline Blvd. and Grizzly Peak to close turn-out areas that had become magnets for illegal dumping and illegal gatherings, they do not fit the more manicured nature of a park in an urban setting such as Lake Merritt
- The logs are acquired through the Tree Division's work in high fire severity zones where dead trees are being removed from evacuation routes; finding uniform logs that are of a species that will last several years could take many months. Identifying logs that will be durable will further delay the project (pine for example begins to decompose within a couple years creating new maintenance challenges).
- The placement of logs is performed by the same staff who are managing the entire City's tree needs and they are at capacity; diverting them from emergency work is not possible, even on overtime and the crews already work a considerable amount of overtime to meet emergent and urgent needs. Placement also requires borrowing equipment from other Public Works Divisions.
- The City is seeing repeated removal of logs from areas where they have been placed and does not have a reliable process to secure them in place. A significant concern is that the logs could be dislodged and rolled into the street creating an even greater safety problem.

Therefore, staff is exploring a third alternative: a wooden guardrail (as pictured in **Attachment B**) that would be anchored in concrete to prevent displacement and harder to breach than a chain-link fence. If graffiti vandals were to tag the wooden guardrail, it can easily be painted. Cost estimates are being gathered still.

Additionally, staff asked about installing picnic tables, barbeque stands, and/or benches in the area where the bathrooms were located to create more recreational gathering spaces, but these ideas were also met with general opposition due to the recent activity and fear that these installations would attract more negative behavior. In particular, the barbeque stands were of great concern due to the proximity to bedroom windows and the wind patters causing the smoke to blow into them constantly. Some neighbors expressed interest in more park benches, noting that for some park goers including seniors, it is not easy to sit on the ground or a picnic blanket and having more benches would allow them to enjoy the park for longer periods of time.

Last, one neighbor promoted the idea of community garden beds being installed in the area where the bathroom was located. Gardening beds have served as a deterrent to unwanted activity in other parks and if there is an interest, this could be pursued through the City's community gardening and stewardship programs.

The Bathroom Replacement:

As noted in the summary, staff identified that the bathroom in Pine Knoll Park was not functional and could not be made ADA compliant by modern standards. Measure Q funds were available to

demolish it and replace it with a Portland Loo on Lakeshore Avenue that would meet those standards. The closure of the park presented an opportunity to perform this work in tandem and staff began to demolish the building and install the Portland Loo. Due to an internal misunderstanding the bathroom replacement project was initiated prior to presenting to the PRAC and prior to seeking Planning approval. When staff recognized the error, the demolition was halted until an appropriate application could be submitted and a determination could be made by Planning staff. Since the building is partially demolished and has been “Red Tagged” by the Building Official, a Minor Conditional Use Permit (CUP) from the City’s Planning and Building Department is required to proceed with the bathroom replacement and part of the process is to seek a recommendation from the PRAC. Once that has happened, staff will proceed with the Minor CUP application.

RECOMMENDATION

Staff recommends the Parks and Recreation Advisory Commission recommend approval of the proposed Minor Conditional Use Permit for the replacement of the bathroom at Pine Knoll Park and the installation of a perimeter wooden fence to prevent future reckless driving within the park. The proposed project will result in a park with improved facilities that better serves the recreational needs of the surrounding area.

Respectfully submitted,



Prepared by:
Joe DeVries
Deputy City Administrator

Attachments: A – OPD Calls for Service to Pine Knoll Park area 11/22-11/23
B – Examples of chicanes, wooden guardrails, and log installations

Pine Knoll Park PRAC Report Attachment A

2022 (24) Incidents

Inc No	EVENT NUMBER	ADDRESS	BEAT	CALL SOURCE TEXT	CREATE TIME INCIDENT	INCIDENT TYPE ID	INCIDENT TYPE DESCRIPTION	Pine Knoll Park-Related
17	LOP221224000119	E 18TH ST&LAKESHORE AV	15X	911 CALL	12/24/2022 3:17	415GS	415 GUNSHOTS	X
2	LOP221111000510	1850 LAKESHORE AV	15X	911 CALL	11/11/2022 12:32	415C	415 UNKNOWN	X
5	LOP221119000661	1830 LAKESHORE AV	15X	DEFAULT - PHONE INIT	11/19/2022 13:39	911C	911 HANG UP FROM CP	X
4	LOP221115000838	HANOVER AV&LAKESHORE AV	15X	DEFAULT - PHONE INIT	11/15/2022 16:23	459AU	AUTO BURGLARY	X
8	LOP221210000794	E 18TH ST&LAKESHORE AV	15X	911 CALL	12/10/2022 19:05	459AU	AUTO BURGLARY	X
11	LOP221216000391	HANOVER AV&LAKESHORE AV	15X	DEFAULT - PHONE INIT	12/16/2022 10:34	INFO	BEAT INFORMATION	X
24	LOP221227000897	1830 LAKESHORE AV	15X	DEFAULT - PHONE INIT	12/27/2022 17:28	BTNFO	BEAT INFORMATION	X
9	LOP221214000977	HANOVER AV&LAKESHORE AV	15X	DEFAULT - PHONE INIT	12/14/2022 19:30	415A	DISTURBANCE-AUTO	X
21	LOP221226000604	HANOVER AV&LAKESHORE AV	15X	DEFAULT - PHONE INIT	12/26/2022 16:45	415A	DISTURBANCE-AUTO	X
16	LOP221218000760	1800 LAKESHORE AV	15X	911 CALL	12/18/2022 18:07	20002	HIT & RUN (PROPERTY	X
10	LOP221214001100	HANOVER AV&LAKESHORE AV	15X	DEFAULT - PHONE INIT	12/14/2022 22:29	415E	LOUD MUSIC	X
19	LOP221225000127	HANOVER AV&LAKESHORE AV	15X	DEFAULT - PHONE INIT	12/25/2022 2:12	415E	LOUD MUSIC	X
20	LOP221225000337	HANOVER AV&LAKESHORE AV	15X	DEFAULT - PHONE INIT	12/25/2022 9:24	MACRO	MACRO TEAM RESPONSE	X
22	LOP221226000679	HANOVER AV&LAKESHORE AV	15X	FIELD INITIATED BY D	12/26/2022 18:11	5150	MENTALLY ILL	X
23	LOP221226000713	HANOVER AV&LAKESHORE AV	15X	FIELD INITIATED BY D	12/26/2022 18:57	OV	ON VIEW	X
18	LOP221224000811	1850 LAKESHORE AV	15X	911 CALL	12/24/2022 20:42	911N	POLICE RELATED MATTE	X
3	LOP221112000637	HANOVER AV&LAKESHORE AV	15X	911 CALL	11/12/2022 16:11	23103	RECKLESS DRIVING	X
6	LOP221201000213	ATHOL AV&WAYNE AV	15X	DEFAULT - PHONE INIT	12/1/2022 7:54	23103	RECKLESS DRIVING	X
7	LOP221201000214	ATHOL AV&WAYNE AV	15X	DEFAULT - PHONE INIT	12/1/2022 7:55	23103	RECKLESS DRIVING	X
14	LOP221217000497	HANOVER AV&LAKESHORE AV	15X	911 CALL	12/17/2022 13:00	23103	RECKLESS DRIVING	X
15	LOP221217000715	HANOVER AV&LAKESHORE AV	15X	911 CALL	12/17/2022 16:45	23103	RECKLESS DRIVING	X
12	LOP221216000838	HANOVER AV&LAKESHORE AV	15X	911 CALL	12/16/2022 17:26	SDSHO	SIDESHOW	X
13	LOP221217000492	E 18TH ST&LAKESHORE AV	15X	DEFAULT - PHONE INIT	12/17/2022 12:53	SIDESH	SIDESHOW	X
1	LOP221104000850	HANOVER AV&LAKESHORE AV	15X	911 CALL	11/4/2022 17:50	955A	VICIOUS ANIMAL	X

2023 (237) Incidents

Inc No	EVENT NUMBER	ADDRESS	BEAT	CALL SOURCE TEXT	CREATE TIME INCIDENT	INCIDENT TYPE ID	INCIDENT TYPE DESCRIPTION	Pine Knoll Park-Related
1	LOP230107000575	HANOVER AV&LAKESHORE AV	15X	DEFAULT - PHONE INIT	1/7/2023 13:46	23103	RECKLESS DRIVING	X
141	LOP230812000025	HANOVER AV&WAYNE AV	15X	DEFAULT - PHONE INIT	8/12/2023 0:23	415FC	415 FIRE CRACKERS	X
88	LOP230615000093	E 18TH ST&2ND AV	15X	911 CALL	6/15/2023 2:52	415GS	415 GUNSHOTS	X
49	LOP230429000071	1800 LAKESHORE AV	15X	911 CALL	4/29/2023 1:32	415C	415 UNKNOWN	X
6	LOP230112000867	1830 LAKESHORE AV	15X	911 CALL	1/12/2023 16:27	911C	911 HANG UP FROM CP	X
47	LOP230423001018	HANOVER AV&LAKESHORE AV	15X	911 CALL	4/23/2023 19:20	911C	911 HANG UP FROM CP	X
57	LOP230507000616	1830 LAKESHORE AV	15X	911 CALL	5/7/2023 13:22	911C	911 HANG UP FROM CP	X
124	LOP230722000630	1824 LAKESHORE AV	15X	911 CALL	7/22/2023 14:19	911C	911 HANG UP FROM CP	X
137	LOP230806000587	HANOVER AV&WAYNE AV	15X	911 CALL	8/6/2023 13:17	911C	911 HANG UP FROM CP	X
147	LOP230816001202	1850 LAKESHORE AV	15X	911 CALL	8/16/2023 21:08	911C	911 HANG UP FROM CP	X
172	LOP230905000122	1830 LAKESHORE AV	15X	911 CALL	9/5/2023 3:15	911C	911 HANG UP FROM CP	X
195	LOP230917000425	1850 LAKESHORE AV	15X	911 CALL	9/17/2023 10:29	911C	911 HANG UP FROM CP	X
201	LOP230924000470	1830 LAKESHORE AV	15X	911 CALL	9/24/2023 11:12	911C	911 HANG UP FROM CP	X
220	LOP231021001079	1850 LAKESHORE AV	15X	911 CALL	10/21/2023 21:48	911C	911 HANG UP FROM CP	X
235	LOP231127000610	1869 LAKESHORE AV	15X	911 CALL	11/27/2023 12:56	911C	911 HANG UP FROM CP	X
22	LOP230220000606	E 18TH ST&2ND AV	15X	DEFAULT - PHONE INIT	2/20/2023 13:45	IA	AFTER HOURS IA REFER	X

145	LOP230815000675	1850 LAKESHORE AV	15X	DEFAULT - PHONE INIT	8/15/2023 13:42	IA	AFTER HOURS IA REFER	X
135	LOP230804000187	HANOVER AV&LAKESHORE AV	15X	DEFAULT - PHONE INIT	8/4/2023 6:46	PD	ASSOCIATED TYPE FROM	X
107	LOP230708000321	1800 LAKESHORE AV	15X	DEFAULT - PHONE INIT	7/8/2023 6:23	970B	AUTO BLOCKING DRIVEW	X
11	LOP230122000616	E 18TH ST&2ND AV	15X	911 CALL	1/22/2023 15:14	459AU	AUTO BURGLARY	X
34	LOP230406000922	E 18TH ST&LAKESHORE AV	15X	911 CALL	4/6/2023 17:32	459AU	AUTO BURGLARY	X
35	LOP230410000031	HANOVER AV&LAKESHORE AV	15X	DEFAULT - PHONE INIT	4/10/2023 0:53	459AU	AUTO BURGLARY	X
36	LOP230416000792	E 18TH ST&LAKESHORE AV	15X	911 CALL	4/16/2023 16:07	459AU	AUTO BURGLARY	X
70	LOP230524000741	E 18TH ST&LAKESHORE AV	15X	911 CALL	5/24/2023 14:21	459AU	AUTO BURGLARY	X
96	LOP230630000963	E 18TH ST&LAKESHORE AV	15X	911 CALL	6/30/2023 17:48	459AU	AUTO BURGLARY	X
100	LOP230701000723	E 18TH ST&2ND AV	15X	911 CALL	7/1/2023 15:41	459AU	AUTO BURGLARY	X
101	LOP230701000724	E 18TH ST&2ND AV	15X	911 CALL	7/1/2023 15:42	459AU	AUTO BURGLARY	X
136	LOP230804000387	HANOVER AV&LAKESHORE AV	15X	911 CALL	8/4/2023 10:44	459AU	AUTO BURGLARY	X
198	LOP230922001029	E 18TH ST&2ND AV	15X	FIELD INITIATED BY D	9/22/2023 17:31	459AU	AUTO BURGLARY	X
215	LOP231011000848	HANOVER AV&WAYNE AV	15X	911 CALL	10/11/2023 15:08	459AU	AUTO BURGLARY	X
112	LOP230713000647	1850 LAKESHORE AV	15X	DEFAULT - PHONE INIT	7/13/2023 14:11	970	AUTO IMPROPERLY PARK	X
86	LOP230613000244	1850 LAKESHORE AV	15X	911 CALL	6/13/2023 7:46	242	BATTERY	X
69	LOP230521000081	E 18TH ST&LAKESHORE AV	15X	911 CALL	5/21/2023 1:39	INFO	BEAT INFORMATION	X
97	LOP230630000968	HANOVER AV&LAKESHORE AV	15X	DEFAULT - PHONE INIT	6/30/2023 17:54	INFO	BEAT INFORMATION	X
25	LOP230305000802	E 18TH ST&ATHOL AV	15X	911 CALL	3/5/2023 18:48	417	BRANDISH A WEAPON	X
71	LOP230527000492	HANOVER AV&WAYNE AV	15X	DEFAULT - PHONE INIT	5/27/2023 12:53	417	BRANDISH A WEAPON	X
92	LOP230622001140	1850 LAKESHORE AV	15X	911 CALL	6/22/2023 18:41	417	BRANDISH A WEAPON	X
93	LOP230625000482	HANOVER AV&LAKESHORE AV	15X	911 CALL	6/25/2023 11:45	417	BRANDISH A WEAPON	X
95	LOP230626001148	1830 LAKESHORE AV	15X	911 CALL	6/26/2023 21:34	417	BRANDISH A WEAPON	X
115	LOP230715000269	E 18TH ST&2ND AV	15X	DEFAULT - PHONE INIT	7/15/2023 7:45	417	BRANDISH A WEAPON	X
173	LOP230905000773	E 18TH ST&LAKESHORE AV	15X	911 CALL	9/5/2023 14:43	417	BRANDISH A WEAPON	X
39	LOP230422000023	E 18TH ST&LAKESHORE AV	15X	DEFAULT - PHONE INIT	4/22/2023 0:21	BCAST	BROADCAST	X
91	LOP230620000066	E 18TH ST&LAKESHORE AV	15X	DEFAULT - PHONE INIT	6/20/2023 1:56	BCAST	BROADCAST	X
171	LOP230904000914	E 18TH ST&LAKESHORE AV	15X	DEFAULT - PHONE INIT	9/4/2023 18:53	BCAST	BROADCAST	X
175	LOP230910000340	E 18TH ST&LAKESHORE AV	15X	DEFAULT - PHONE INIT	9/10/2023 9:26	BCAST	BROADCAST	X
28	LOP230306000045	HANOVER AV&WAYNE AV	15X	FIELD INITIATED BY D	3/6/2023 1:25	976	CAR STOP	X
64	LOP230514000819	HANOVER AV&LAKESHORE AV	15X	FIELD INITIATED BY D	5/14/2023 17:11	976	CAR STOP	X
68	LOP230519000457	HANOVER AV&LAKESHORE AV	15X	FIELD INITIATED BY D	5/19/2023 10:22	976	CAR STOP	X
223	LOP231103000321	1800 LAKESHORE AV	15X	FIELD INITIATED BY D	11/3/2023 8:36	976	CAR STOP	X
143	LOP230814000097	HANOVER AV&WAYNE AV	15X	DEFAULT - PHONE INIT	8/14/2023 2:31	CKVEH	CHECK VEHICLE	X
17	LOP230207000789	1800 LAKESHORE AV	15X	DEFAULT - PHONE INIT	2/7/2023 15:50	COMM	COMM ORDER	X
48	LOP230427000619	HANOVER AV&LAKESHORE AV	15X	DEFAULT - PHONE INIT	4/27/2023 13:28	COMM	COMM ORDER	X
192	LOP230916000889	1800 LAKESHORE AV	15X	DEFAULT - PHONE INIT	9/16/2023 16:55	COMM	COMM ORDER	X
207	LOP230927000411	1830 LAKESHORE AV	15X	DEFAULT - PHONE INIT	9/27/2023 10:00	COMM	COMM ORDER	X
211	LOP231005001033	1850 LAKESHORE AV	15X	DEFAULT - PHONE INIT	10/5/2023 17:20	597	CRUELTY TO ANIMAL	X
84	LOP230611000879	HANOVER AV&LAKESHORE AV	15X	DEFAULT - PHONE INIT	6/11/2023 19:30	647F	DISORDERLY CONDUCT:	X
13	LOP230123000421	1830 LAKESHORE AV	15X	DEFAULT - PHONE INIT	1/23/2023 10:26	415A	DISTURBANCE-AUTO	X
18	LOP230207001026	1830 LAKESHORE AV	15X	DEFAULT - PHONE INIT	2/7/2023 18:49	415A	DISTURBANCE-AUTO	X
149	LOP230819000126	HANOVER AV&LAKESHORE AV	15X	DEFAULT - PHONE INIT	8/19/2023 2:56	415A	DISTURBANCE-AUTO	X
191	LOP230916000675	HANOVER AV&LAKESHORE AV	15X	DEFAULT - PHONE INIT	9/16/2023 13:51	415A	DISTURBANCE-AUTO	X
174	LOP230907000944	HANOVER AV&LAKESHORE AV	15X	911 CALL	9/7/2023 17:47	415J	DISTURBANCE-JUVENILE	X

89	LOP230615001242	E 18TH ST&LAKESHORE AV	15X	911 CALL	6/15/2023 22:54	415	DISTURBING THE PEACE	X
123	LOP230720001103	E 18TH ST&LAKESHORE AV	15X	911 CALL	7/20/2023 20:34	415	DISTURBING THE PEACE	X
138	LOP230806000589	HANOVER AV&LAKESHORE AV	15X	911 CALL	8/6/2023 13:19	415	DISTURBING THE PEACE	X
140	LOP230811000889	HANOVER AV&LAKESHORE AV	15X	DEFAULT - PHONE INIT	8/11/2023 17:47	415	DISTURBING THE PEACE	X
153	LOP230820000876	HANOVER AV&LAKESHORE AV	15X	DEFAULT - PHONE INIT	8/20/2023 16:50	415	DISTURBING THE PEACE	X
170	LOP230904000692	1850 LAKESHORE AV	15X	911 CALL	9/4/2023 15:23	415	DISTURBING THE PEACE	X
200	LOP230924000018	HANOVER AV&WAYNE AV	15X	911 CALL	9/24/2023 0:14	415	DISTURBING THE PEACE	X
3	LOP230109000541	1830 LAKESHORE AV	15X	DEFAULT - PHONE INIT	1/9/2023 12:24	11500	DRUG DEALING	X
184	LOP230911001066	HANOVER AV&LAKESHORE AV	15X	911 CALL	9/11/2023 18:53	EVAL	EVALUATION	X
204	LOP230925000995	1830 LAKESHORE AV	15X	DEFAULT - PHONE INIT	9/25/2023 17:24	HAZ	HAZARDOUS SITUATION/	X
142	LOP230813000905	E 18TH ST&LAKESHORE AV	15X	911 CALL	8/13/2023 18:28	20002	HIT & RUN (PROPERTY	X
50	LOP230429001068	E 18TH ST&ATHOL AV	15X	911 CALL	4/29/2023 22:15	20001	HIT & RUN RESULTING	X
14	LOP230125001094	1830 LAKESHORE AV	15X	DEFAULT - PHONE INIT	1/25/2023 19:59	415E	LOUD MUSIC	X
37	LOP230416000810	HANOVER AV&LAKESHORE AV	15X	DEFAULT - PHONE INIT	4/16/2023 16:22	415E	LOUD MUSIC	X
56	LOP230507000119	HANOVER AV&LAKESHORE AV	15X	DEFAULT - PHONE INIT	5/7/2023 2:23	415E	LOUD MUSIC	X
106	LOP230708000172	1830 LAKESHORE AV	15X	DEFAULT - PHONE INIT	7/8/2023 2:33	415E	LOUD MUSIC	X
111	LOP230713000611	HANOVER AV&LAKESHORE AV	15X	DEFAULT - PHONE INIT	7/13/2023 13:39	415E	LOUD MUSIC	X
122	LOP230719001212	E 18TH ST&LAKESHORE AV	15X	DEFAULT - PHONE INIT	7/19/2023 22:21	415E	LOUD MUSIC	X
31	LOP230324000904	HANOVER AV&LAKESHORE AV	15X	911 CALL	3/24/2023 18:16	MACRO	MACRO TEAM RESPONSE	X
76	LOP230531000249	E 18TH ST&LAKESHORE AV	15X	911 CALL	5/31/2023 7:28	MACRO	MACRO TEAM RESPONSE	X
148	LOP230817000319	HANOVER AV&LAKESHORE AV	15X	DEFAULT - PHONE INIT	8/17/2023 8:44	MACRO	MACRO TEAM RESPONSE	X
224	LOP231105000512	HANOVER AV&LAKESHORE AV	15X	911 CALL	11/5/2023 10:55	MACRO	MACRO TEAM RESPONSE	X
114	LOP230715000108	E 18TH ST&LAKESHORE AV	15X	DEFAULT - PHONE INIT	7/15/2023 2:51	5150	MENTALLY ILL	X
121	LOP230719000109	HANOVER AV&LAKESHORE AV	15X	911 CALL	7/19/2023 3:03	5150	MENTALLY ILL	X
127	LOP230728000002	HANOVER AV&LAKESHORE AV	15X	911 CALL	7/28/2023 0:02	5150	MENTALLY ILL	X
197	LOP230919000950	E 18TH ST&LAKESHORE AV	15X	DEFAULT - PHONE INIT	9/19/2023 16:01	5150	MENTALLY ILL	X
202	LOP230924000577	HANOVER AV&LAKESHORE AV	15X	FIELD INITIATED BY D	9/24/2023 13:09	5150	MENTALLY ILL	X
218	LOP231017000432	HANOVER AV&LAKESHORE AV	15X	DEFAULT - PHONE INIT	10/17/2023 9:55	5150	MENTALLY ILL	X
236	LOP231127001137	E 18TH ST&LAKESHORE AV	15X	911 CALL	11/27/2023 20:00	5150	MENTALLY ILL	X
19	LOP230216001116	1824 LAKESHORE AV	15X	911 CALL	2/16/2023 21:26	OMC	OAKLAND MUNICIPLE CO	X
90	LOP230616000423	1850 LAKESHORE AV	15X	DEFAULT - PHONE INIT	6/16/2023 10:13	OMC	OAKLAND MUNICIPLE CO	X
7	LOP230114000233	E 18TH ST&2ND AV	15X	FIELD INITIATED BY D	1/14/2023 7:48	OV	ON VIEW	X
21	LOP230220000600	E 18TH ST&2ND AV	15X	FIELD INITIATED BY D	2/20/2023 13:40	OV	ON VIEW	X
27	LOP230306000018	E 18TH ST&2ND AV	15X	FIELD INITIATED BY D	3/6/2023 0:43	OV	ON VIEW	X
40	LOP230422000029	HANOVER AV&LAKESHORE AV	15X	FIELD INITIATED BY D	4/22/2023 0:25	OV	ON VIEW	X
42	LOP230423000634	HANOVER AV&LAKESHORE AV	15X	FIELD INITIATED BY D	4/23/2023 13:29	OV	ON VIEW	X
87	LOP230614000491	E 18TH ST&2ND AV	15X	FIELD INITIATED BY D	6/14/2023 11:13	OV	ON VIEW	X
159	LOP230820001338	E 18TH ST&LAKESHORE AV	15X	FIELD INITIATED BY D	8/20/2023 23:18	OV	ON VIEW	X
169	LOP230903001268	HANOVER AV&LAKESHORE AV	15X	FIELD INITIATED BY D	9/3/2023 22:50	OV	ON VIEW	X
180	LOP230910000943	1800 LAKESHORE AV	15X	FIELD INITIATED BY D	9/10/2023 18:52	OV	ON VIEW	X
187	LOP230914001439	1800 LAKESHORE AV	15X	FIELD INITIATED BY D	9/14/2023 22:58	OV	ON VIEW	X
203	LOP230924000797	HANOVER AV&LAKESHORE AV	15X	FIELD INITIATED BY D	9/24/2023 16:54	OV	ON VIEW	X
210	LOP231004000110	HANOVER AV&LAKESHORE AV	15X	FIELD INITIATED BY D	10/4/2023 2:18	OV	ON VIEW	X
212	LOP231007000714	HANOVER AV&LAKESHORE AV	15X	FIELD INITIATED BY D	10/7/2023 14:50	OV	ON VIEW	X
230	LOP231119000275	HANOVER AV&LAKESHORE AV	15X	FIELD INITIATED BY D	11/19/2023 7:20	OV	ON VIEW	X

237	LOP231128000057	E 18TH ST&LAKESHORE AV	15X	FIELD INITIATED BY D	11/28/2023 1:08	OV	ON VIEW	X
63	LOP230513000742	E 18TH ST&2ND AV	15X	911 CALL	5/13/2023 15:35	OD	OVERDOSE	X
4	LOP230109000852	HANOVER AV&LAKESHORE AV	15X	911 CALL	1/9/2023 17:12	911N	POLICE RELATED MATTE	X
85	LOP230611001125	HANOVER AV&LAKESHORE AV	15X	911 CALL	6/11/2023 23:43	911N	POLICE RELATED MATTE	X
118	LOP230717000109	HANOVER AV&LAKESHORE AV	15X	DEFAULT - PHONE INIT	7/17/2023 3:05	911N	POLICE RELATED MATTE	X
144	LOP230814000408	HANOVER AV&LAKESHORE AV	15X	911 CALL	8/14/2023 10:01	911N	POLICE RELATED MATTE	X
151	LOP230820000637	E 18TH ST&LAKESHORE AV	15X	911 CALL	8/20/2023 13:01	911N	POLICE RELATED MATTE	X
229	LOP231115001202	E 18TH ST&LAKESHORE AV	15X	911 CALL	11/15/2023 21:34	911N	POLICE RELATED MATTE	X
2	LOP230108000685	HANOVER AV&LAKESHORE AV	15X	DEFAULT - PHONE INIT	1/8/2023 16:08	23103	RECKLESS DRIVING	X
5	LOP230111000381	E 18TH ST&LAKESHORE AV	15X	911 CALL	1/11/2023 11:21	23103	RECKLESS DRIVING	X
8	LOP230115000610	HANOVER AV&LAKESHORE AV	15X	911 CALL	1/15/2023 14:35	23103	RECKLESS DRIVING	X
9	LOP230115000614	HANOVER AV&LAKESHORE AV	15X	DEFAULT - PHONE INIT	1/15/2023 14:40	23103	RECKLESS DRIVING	X
10	LOP230122000503	HANOVER AV&LAKESHORE AV	15X	911 CALL	1/22/2023 13:26	23103	RECKLESS DRIVING	X
23	LOP230223000150	E 18TH ST&LAKESHORE AV	15X	DEFAULT - PHONE INIT	2/23/2023 5:43	23103	RECKLESS DRIVING	X
29	LOP230318000590	HANOVER AV&LAKESHORE AV	15X	DEFAULT - PHONE INIT	3/18/2023 13:48	23103	RECKLESS DRIVING	X
30	LOP230318000835	E 18TH ST&LAKESHORE AV	15X	911 CALL	3/18/2023 17:41	23103	RECKLESS DRIVING	X
32	LOP230402000676	E 18TH ST&2ND AV	15X	911 CALL	4/2/2023 15:07	23103	RECKLESS DRIVING	X
41	LOP230422000786	HANOVER AV&LAKESHORE AV	15X	DEFAULT - PHONE INIT	4/22/2023 16:39	23103	RECKLESS DRIVING	X
44	LOP230423000974	HANOVER AV&LAKESHORE AV	15X	DEFAULT - PHONE INIT	4/23/2023 18:37	23103	RECKLESS DRIVING	X
45	LOP230423000999	HANOVER AV&LAKESHORE AV	15X	911 CALL	4/23/2023 19:06	23103	RECKLESS DRIVING	X
46	LOP230423001017	HANOVER AV&LAKESHORE AV	15X	911 CALL	4/23/2023 19:19	23103	RECKLESS DRIVING	X
51	LOP230430000647	HANOVER AV&LAKESHORE AV	15X	911 CALL	4/30/2023 15:00	23103	RECKLESS DRIVING	X
52	LOP230430000840	E 18TH ST&LAKESHORE AV	15X	DEFAULT - PHONE INIT	4/30/2023 17:25	23103	RECKLESS DRIVING	X
55	LOP230505000876	HANOVER AV&LAKESHORE AV	15X	911 CALL	5/5/2023 16:43	23103	RECKLESS DRIVING	X
58	LOP230507000678	HANOVER AV&LAKESHORE AV	15X	911 CALL	5/7/2023 14:28	23103	RECKLESS DRIVING	X
59	LOP230507000703	HANOVER AV&LAKESHORE AV	15X	911 CALL	5/7/2023 14:45	23103	RECKLESS DRIVING	X
60	LOP230507000749	HANOVER AV&LAKESHORE AV	15X	DEFAULT - PHONE INIT	5/7/2023 15:29	23103	RECKLESS DRIVING	X
62	LOP230512000864	E 18TH ST&LAKESHORE AV	15X	911 CALL	5/12/2023 16:49	23103	RECKLESS DRIVING	X
66	LOP230515001293	HANOVER AV&LAKESHORE AV	15X	DEFAULT - PHONE INIT	5/15/2023 23:08	23103	RECKLESS DRIVING	X
67	LOP230517001052	HANOVER AV&LAKESHORE AV	15X	DEFAULT - PHONE INIT	5/17/2023 18:20	23103	RECKLESS DRIVING	X
72	LOP230528000806	HANOVER AV&LAKESHORE AV	15X	911 CALL	5/28/2023 18:27	23103	RECKLESS DRIVING	X
73	LOP230529000916	HANOVER AV&LAKESHORE AV	15X	911 CALL	5/29/2023 19:43	23103	RECKLESS DRIVING	X
75	LOP230529000928	1830 LAKESHORE AV	15X	911 CALL	5/29/2023 19:55	23103	RECKLESS DRIVING	X
77	LOP230531001113	E 18TH ST&LAKESHORE AV	15X	911 CALL	5/31/2023 19:57	23103	RECKLESS DRIVING	X
78	LOP230531001130	E 18TH ST&LAKESHORE AV	15X	911 CALL	5/31/2023 20:12	23103	RECKLESS DRIVING	X
79	LOP230604000618	HANOVER AV&LAKESHORE AV	15X	911 CALL	6/4/2023 15:07	23103	RECKLESS DRIVING	X
80	LOP230607000918	HANOVER AV&LAKESHORE AV	15X	911 CALL	6/7/2023 17:53	23103	RECKLESS DRIVING	X
83	LOP230611000875	HANOVER AV&LAKESHORE AV	15X	911 CALL	6/11/2023 19:27	23103	RECKLESS DRIVING	X
94	LOP230625000706	1830 LAKESHORE AV	15X	911 CALL	6/25/2023 15:34	23103	RECKLESS DRIVING	X
102	LOP230702000736	HANOVER AV&LAKESHORE AV	15X	911 CALL	7/2/2023 15:43	23103	RECKLESS DRIVING	X
109	LOP230709000640	HANOVER AV&LAKESHORE AV	15X	DEFAULT - PHONE INIT	7/9/2023 15:04	23103	RECKLESS DRIVING	X
116	LOP230716000805	HANOVER AV&LAKESHORE AV	15X	911 CALL	7/16/2023 15:28	23103	RECKLESS DRIVING	X
119	LOP230717000812	E 18TH ST&LAKESHORE AV	15X	911 CALL	7/17/2023 15:55	23103	RECKLESS DRIVING	X
125	LOP230722000905	HANOVER AV&LAKESHORE AV	15X	911 CALL	7/22/2023 18:38	23103	RECKLESS DRIVING	X
126	LOP230723000736	1850 LAKESHORE AV	15X	DEFAULT - PHONE INIT	7/23/2023 15:41	23103	RECKLESS DRIVING	X

129	LOP23073000843	HANOVER AV&LAKESHORE AV	15X	911 CALL	7/30/2023 18:14	23103	RECKLESS DRIVING	X
130	LOP23073000844	HANOVER AV&LAKESHORE AV	15X	911 CALL	7/30/2023 18:15	23103	RECKLESS DRIVING	X
132	LOP23073000882	HANOVER AV&LAKESHORE AV	15X	DEFAULT - PHONE INIT	7/30/2023 18:59	23103	RECKLESS DRIVING	X
133	LOP230801001112	1850 LAKESHORE AV	15X	DEFAULT - PHONE INIT	8/1/2023 19:28	23103	RECKLESS DRIVING	X
139	LOP230807001119	HANOVER AV&LAKESHORE AV	15X	911 CALL	8/7/2023 20:44	23103	RECKLESS DRIVING	X
146	LOP230815001192	HANOVER AV&LAKESHORE AV	15X	911 CALL	8/15/2023 21:23	23103	RECKLESS DRIVING	X
150	LOP230819000886	E 18TH ST&LAKESHORE AV	15X	911 CALL	8/19/2023 18:14	23103	RECKLESS DRIVING	X
152	LOP230820000875	HANOVER AV&LAKESHORE AV	15X	911 CALL	8/20/2023 16:49	23103	RECKLESS DRIVING	X
154	LOP230820000899	E 18TH ST&LAKESHORE AV	15X	911 CALL	8/20/2023 17:09	23103	RECKLESS DRIVING	X
156	LOP230820001021	1850 LAKESHORE AV	15X	DEFAULT - PHONE INIT	8/20/2023 18:54	23103	RECKLESS DRIVING	X
160	LOP230824000971	HANOVER AV&LAKESHORE AV	15X	911 CALL	8/24/2023 19:13	23103	RECKLESS DRIVING	X
161	LOP230826000113	HANOVER AV&LAKESHORE AV	15X	911 CALL	8/26/2023 3:00	23103	RECKLESS DRIVING	X
162	LOP230826000114	1830 LAKESHORE AV	15X	DEFAULT - PHONE INIT	8/26/2023 3:02	23103	RECKLESS DRIVING	X
163	LOP230826000962	E 18TH ST&LAKESHORE AV	15X	911 CALL	8/26/2023 19:54	23103	RECKLESS DRIVING	X
164	LOP230826000973	HANOVER AV&LAKESHORE AV	15X	911 CALL	8/26/2023 20:04	23103	RECKLESS DRIVING	X
176	LOP230910000830	HANOVER AV&LAKESHORE AV	15X	911 CALL	9/10/2023 17:18	23103	RECKLESS DRIVING	X
177	LOP230910000851	HANOVER AV&LAKESHORE AV	15X	DEFAULT - PHONE INIT	9/10/2023 17:34	23103	RECKLESS DRIVING	X
181	LOP230910000988	HANOVER AV&LAKESHORE AV	15X	911 CALL	9/10/2023 19:18	23103	RECKLESS DRIVING	X
188	LOP230915001207	HANOVER AV&LAKESHORE AV	15X	911 CALL	9/15/2023 20:06	23103	RECKLESS DRIVING	X
190	LOP230916000170	HANOVER AV&LAKESHORE AV	15X	911 CALL	9/16/2023 3:20	23103	RECKLESS DRIVING	X
196	LOP230917000824	1850 LAKESHORE AV	15X	911 CALL	9/17/2023 17:25	23103	RECKLESS DRIVING	X
205	LOP230926001050	HANOVER AV&LAKESHORE AV	15X	911 CALL	9/26/2023 18:56	23103	RECKLESS DRIVING	X
208	LOP231001000807	HANOVER AV&LAKESHORE AV	15X	DEFAULT - PHONE INIT	10/1/2023 18:17	23103	RECKLESS DRIVING	X
209	LOP231002001380	1830 LAKESHORE AV	15X	DEFAULT - PHONE INIT	10/2/2023 23:22	23103	RECKLESS DRIVING	X
213	LOP231007000975	E 18TH ST&LAKESHORE AV	15X	DEFAULT - PHONE INIT	10/7/2023 18:27	23103	RECKLESS DRIVING	X
221	LOP231027000580	HANOVER AV&LAKESHORE AV	15X	DEFAULT - PHONE INIT	10/27/2023 12:47	23103	RECKLESS DRIVING	X
222	LOP231029000675	1850 LAKESHORE AV	15X	DEFAULT - PHONE INIT	10/29/2023 16:14	23103	RECKLESS DRIVING	X
227	LOP231111000864	HANOVER AV&WAYNE AV	15X	DEFAULT - PHONE INIT	11/11/2023 17:25	23103	RECKLESS DRIVING	X
228	LOP231112000655	HANOVER AV&LAKESHORE AV	15X	DEFAULT - PHONE INIT	11/12/2023 13:55	23103	RECKLESS DRIVING	X
234	LOP231123000670	E 18TH ST&LAKESHORE AV	15X	DEFAULT - PHONE INIT	11/23/2023 15:26	23103	RECKLESS DRIVING	X
82	LOP230611000021	HANOVER AV&LAKESHORE AV	15X	FIELD INITIATED BY D	6/11/2023 0:20	SECCK	SECURITY CHECK	X
104	LOP230702001183	HANOVER AV&LAKESHORE AV	15X	FIELD INITIATED BY D	7/2/2023 21:48	SECCK	SECURITY CHECK	X
105	LOP230704000815	HANOVER AV&LAKESHORE AV	15X	FIELD INITIATED BY D	7/4/2023 18:04	SECCK	SECURITY CHECK	X
108	LOP230708001113	E 18TH ST&LAKESHORE AV	15X	FIELD INITIATED BY D	7/8/2023 20:17	SECCK	SECURITY CHECK	X
120	LOP230718000858	HANOVER AV&LAKESHORE AV	15X	FIELD INITIATED BY D	7/18/2023 15:28	SECCK	SECURITY CHECK	X
134	LOP230804000034	HANOVER AV&LAKESHORE AV	15X	FIELD INITIATED BY D	8/4/2023 0:59	SECCK	SECURITY CHECK	X
182	LOP230910001100	1830 LAKESHORE AV	15X	911 CALL	9/10/2023 21:04	SECCK	SECURITY CHECK	X
183	LOP230911001065	1850 LAKESHORE AV	15X	911 CALL	9/11/2023 18:51	SECCK	SECURITY CHECK	X
185	LOP230912000061	HANOVER AV&LAKESHORE AV	15X	FIELD INITIATED BY D	9/12/2023 1:30	SECCK	SECURITY CHECK	X
186	LOP230912000179	E 18TH ST&LAKESHORE AV	15X	FIELD INITIATED BY D	9/12/2023 4:30	SECCK	SECURITY CHECK	X
193	LOP230916001268	HANOVER AV&LAKESHORE AV	15X	FIELD INITIATED BY D	9/16/2023 22:01	SECCK	SECURITY CHECK	X
194	LOP230916001393	HANOVER AV&LAKESHORE AV	15X	FIELD INITIATED BY D	9/16/2023 23:54	SECCK	SECURITY CHECK	X
199	LOP230923000888	HANOVER AV&LAKESHORE AV	15X	FIELD INITIATED BY D	9/23/2023 18:16	SECCK	SECURITY CHECK	X
216	LOP231015000547	1850 LAKESHORE AV	15X	FIELD INITIATED BY D	10/15/2023 13:08	SECCK	SECURITY CHECK	X
217	LOP231015000752	HANOVER AV&LAKESHORE AV	15X	FIELD INITIATED BY D	10/15/2023 16:39	SECCK	SECURITY CHECK	X

219	LOP231021000709	HANOVER AV&LAKESHORE AV	15X	FIELD INITIATED BY D	10/21/2023 15:28	SECCK	SECURITY CHECK	X
12	LOP230122000708	HANOVER AV&LAKESHORE AV	15X	911 CALL	1/22/2023 16:45	SIDESH	SIDESHOW	X
15	LOP230207000737	HANOVER AV&LAKESHORE AV	15X	DEFAULT - PHONE INIT	2/7/2023 15:19	SIDESH	SIDESHOW	X
38	LOP230416001089	HANOVER AV&LAKESHORE AV	15X	911 CALL	4/16/2023 20:25	SDESHO	SIDESHOW	X
43	LOP230423000971	HANOVER AV&LAKESHORE AV	15X	911 CALL	4/23/2023 18:37	SIDESH	SIDESHOW	X
53	LOP230430001015	HANOVER AV&LAKESHORE AV	15X	DEFAULT - PHONE INIT	4/30/2023 19:44	SDESHO	SIDESHOW	X
54	LOP230501001004	HANOVER AV&LAKESHORE AV	15X	911 CALL	5/1/2023 19:47	SIDESH	SIDESHOW	X
61	LOP230507000762	HANOVER AV&LAKESHORE AV	15X	DEFAULT - PHONE INIT	5/7/2023 15:55	SIDESH	SIDESHOW	X
74	LOP230529000927	HANOVER AV&LAKESHORE AV	15X	911 CALL	5/29/2023 19:54	SIDESH	SIDESHOW	X
98	LOP230630001244	HANOVER AV&LAKESHORE AV	15X	DEFAULT - PHONE INIT	6/30/2023 21:42	SIDESH	SIDESHOW	X
99	LOP230630001247	HANOVER AV&LAKESHORE AV	15X	911 CALL	6/30/2023 21:44	SIDESH	SIDESHOW	X
103	LOP230702000933	HANOVER AV&LAKESHORE AV	15X	911 CALL	7/2/2023 18:03	SIDESH	SIDESHOW	X
110	LOP230709000810	HANOVER AV&LAKESHORE AV	15X	DEFAULT - PHONE INIT	7/9/2023 17:04	SIDESH	SIDESHOW	X
117	LOP230716001088	HANOVER AV&LAKESHORE AV	15X	911 CALL	7/16/2023 19:06	SIDESH	SIDESHOW	X
131	LOP230730000860	HANOVER AV&LAKESHORE AV	15X	911 CALL	7/30/2023 18:31	SIDESH	SIDESHOW	X
155	LOP230820001016	HANOVER AV&LAKESHORE AV	15X	911 CALL	8/20/2023 18:50	SIDESH	SIDESHOW	X
157	LOP230820001099	HANOVER AV&LAKESHORE AV	15X	DEFAULT - PHONE INIT	8/20/2023 20:05	SIDESH	SIDESHOW	X
158	LOP230820001112	1850 LAKESHORE AV	15X	DEFAULT - PHONE INIT	8/20/2023 20:13	SIDESH	SIDESHOW	X
165	LOP230826000975	HANOVER AV&LAKESHORE AV	15X	911 CALL	8/26/2023 20:06	SIDESH	SIDESHOW	X
166	LOP230827000863	HANOVER AV&LAKESHORE AV	15X	DEFAULT - PHONE INIT	8/27/2023 18:56	SIDESH	SIDESHOW	X
167	LOP230903001203	HANOVER AV&LAKESHORE AV	15X	911 CALL	9/3/2023 21:50	SIDESH	SIDESHOW	X
168	LOP230903001224	HANOVER AV&LAKESHORE AV	15X	DEFAULT - PHONE INIT	9/3/2023 22:00	SIDESH	SIDESHOW	X
178	LOP230910000856	HANOVER AV&LAKESHORE AV	15X	DEFAULT - PHONE INIT	9/10/2023 17:37	SIDESH	SIDESHOW	X
179	LOP230910000878	HANOVER AV&LAKESHORE AV	15X	DEFAULT - PHONE INIT	9/10/2023 17:52	SIDESH	SIDESHOW	X
189	LOP230916000163	HANOVER AV&LAKESHORE AV	15X	911 CALL	9/16/2023 3:10	SIDESH	SIDESHOW	X
214	LOP231007001099	HANOVER AV&WAYNE AV	15X	911 CALL	10/7/2023 20:07	SIDESH	SIDESHOW	X
225	LOP231106000560	E 18TH ST&LAKESHORE AV	15X	911 CALL	11/6/2023 12:39	975	STAND BY AND PRESERV	X
16	LOP230207000751	1800 LAKESHORE AV	15X	MDT-INITIATED	2/7/2023 15:28	10851	STOLEN VEHICLE	X
206	LOP230927000200	1830 LAKESHORE AV	15X	DEFAULT - PHONE INIT	9/27/2023 6:32	10851	STOLEN VEHICLE	X
233	LOP231122000650	E 18TH ST&2ND AV	15X	911 CALL	11/22/2023 13:33	10851	STOLEN VEHICLE	X
81	LOP230610000127	E 18TH ST&LAKESHORE AV	15X	911 CALL	6/10/2023 3:08	CODE7	SUBJECT ARMED WITH W	X
33	LOP230403000927	1830 LAKESHORE AV	15X	DEFAULT - PHONE INIT	4/3/2023 16:32	602L	TRESPASS:	X
231	LOP231120000599	1830 LAKESHORE AV	15X	911 CALL	11/20/2023 12:58	602L	TRESPASS:	X
232	LOP231122000477	HANOVER AV&LAKESHORE AV	15X	911 CALL	11/22/2023 11:07	602L	TRESPASS:	X
65	LOP230515001276	E 18TH ST&LAKESHORE AV	15X	911 CALL	5/15/2023 22:54	901	VEHICLE COLLISION/PR	X
20	LOP230220000522	E 18TH ST&2ND AV	15X	911 CALL	2/20/2023 12:29	901A	VEHICLE COLLISION-PE	X
26	LOP230305000983	E 18TH ST&LAKESHORE AV	15X	911 CALL	3/5/2023 22:59	901A	VEHICLE COLLISION-PE	X
113	LOP230714001356	HANOVER AV&LAKESHORE AV	15X	911 CALL	7/14/2023 23:07	901A	VEHICLE COLLISION-PE	X
226	LOP231108000891	E 18TH ST&LAKESHORE AV	15X	911 CALL	11/8/2023 15:36	901A	VEHICLE COLLISION-PE	X
24	LOP230224000294	1830 LAKESHORE AV	15X	DEFAULT - PHONE INIT	2/24/2023 9:33	901B	VEHICLE COLLISION-UN	X
128	LOP230729000209	E 18TH ST&LAKESHORE AV	15X	DEFAULT - PHONE INIT	7/29/2023 6:25	901B	VEHICLE COLLISION-UN	X

Pine Knoll Park Design Images

Wooden Guardrail (example, actual rail would likely have two horizontal planks and be 4 feet tall):



Chicane (examples, staff will try to match the design aesthetically with the perimeter option)



Log Barriers





CITY OF OAKLAND
Oakland Parks, Recreation & Youth Development

TO: Tam Tran, Chair, Parks and Recreation Advisory Commission
FROM: Rebecca Darr, Project Manager, Oakland Public works
DATE: February 14, 2024
SUBJECT: PUBLIC HEARING AND REQUEST FOR THE PARKS AND RECREATION ADVISORY COMMISSION (PRAC) TO MAKE A RECOMMENDATION TO GRANT A MINOR CONDITIONAL USE PERMIT FOR PERALTA PARK ENCLOSURE BY A DECORATIVE EIGHT-FEET HIGH, BLACK STEEL PICKET SECURITY FENCE.

SUMMARY

This report seeks the Park and Recreation Advisory Commission’s recommendation to approve a Minor Conditional Use Permit to install an eight-foot high, black steel picket fence with four gates at major points of entry into Peralta Park. The fence is needed to ensure that no re-encampments can occur once closed, along with public safety and the ability of Oakland Public Works (OPW) to complete planting efforts, monitoring and reporting on plant survival over a period of ten years in order to close out environmental regulatory permits with the US Army Corps of Engineers, the Regional Water Quality Control Board and California Department of Fish & Wildlife.

The installation of a fence to entirely enclose the park with gates that will be locked at night, are the result of numerous meetings with City agencies charged with public safety and homeless encampments, adjacent institutions, OPRYD, Measure DD Coalition and the environmental regulatory agencies. OPW cannot ensure permit compliance for this site without securing it in such a way that, once existing encampments are closed, no new camp sites can occur.

The park is currently unusable and access to the park path along the Lake Merritt Channel is blocked by encampments beneath the 10th Street Bridge to the south, and Lake Merritt Boulevard Bridges to the north.

The City’s Emergency Management Team has closed encampments at this site four times in the past two years and completed deep cleanings five times. Within weeks, and sometimes days, of completing this work new camps have been set up. Currently, the encampment status of the park is the worst it has been in the past two years, with increased damage to City property and greater threats to personal safety of the general public and OPRYD staff.

FISCAL IMPACT

There will be no fiscal impact on the Office of Parks, Recreation & Youth Development (OPRYD). The fence fabrication and installation is funded by Bond Measure DD, approved by the Oakland voters in November 2002. The fence enclosure work is estimated at \$270,000.

After fence installation work is complete, and the City's Emergency Management Team have completed closure of the encampments and removal of significant debris, there are no maintenance costs of note anticipated for this fence. It is pre-fabricated, heavy gauge steel with primer and a gloss black powder coating. It will allow resumption of routine park maintenance and use of the park by the general public for recreational and educational activities. Park and facility maintenance will be provided by the OPW's Bureau of Environment & Facilities as part of their annual budget for this work. No new OPRYD staff is required to operate the facility and programs once the fence is installed.

BACKGROUND / LEGISLATIVE HISTORY

Bond Measure DD, the Oakland Trust for Clean Water and Safe Parks, was passed by the citizens of Oakland in November 2002. The purpose of Measure DD was to improve water quality, provide educational and recreational facilities for children, and provide safe public spaces, among other goals.

The project site is the result of decades of planning for improving Lake Merritt's water quality by widening the channel by providing free-span bridges at 12th and 10th Streets while also providing upgrades and enhancements to the southern end of Lake Merritt. As part of the larger Oakland Bay Trail network, both the 12th and 10th Street Bridge projects were to provide a continuous pedestrian and bike greenway along the water's edge from the Lake to the Oakland Inner Harbor Tidal Canal and San Francisco Bay.

With the construction of the 12th Street Bridge, Peralta Park was enhanced with native plantings, a tot lot installed, special bio storm drain structures built to manage stormwater runoff from the bridge, roadway, and parking lots for the Kaiser Convention Center development. A special tidal marshland environment was created for additional wildlife habitat, greater management of stormwater, and as an educational resource.

The 10th Street Bridge construction completed portions of the park plantings and irrigation systems on both sides of the channel as part of its scope of work.

Both projects required permits from the US Army Corps of Engineers, the San Francisco Regional Water Quality Control Board and the California Department of Fish & Wildlife. Compliance with those permits' requirements for plant survival rates were never met, and as a result remain open.

Unfortunately, in the years ensuing construction demobilization for the 10th Street Bridge Project in 2017, numerous changes in project management, a pandemic and an ever-increasing number of unhoused using public spaces for encampments, Peralta Park and the bridges themselves, became a magnet for encampments, and the channel was used for bathing in the summers. Destruction of irrigation systems, plants, shrubs and perennials ensued.

In February of 2022, in an effort to resume work of closing out the permits and to protect the most vulnerable part of the park, the tidal marshlands, an 8'-high black steel picket fence was installed following camp closures in the park to prevent re-encampments, and to allow trees, shrubs and a host of wetland plantings recover.

Unfortunately, the pressure on public spaces has only increased since then. Today, everywhere in Peralta Park that is not fenced off, has been taken over by encampments with extensive damage to natural resources and City infrastructure. This comes with heightened concerns for public health and safety, and protecting work in which the City has invested significant funds and resources, as have neighboring institutions such as Laney College, the Kaiser Convention Center Development, and nearby public schools.

The park land is an OPRYD asset.

The goals for the proposed full enclosure of Peralta Park with a second fence like the one installed to protect the wetlands, are as follows:

1. Provide a safe working environment in which a contractor and the City Resident Engineer can mobilize to complete the permit required, repair the irrigation systems and a site for which a three-year maintenance and warranty component of the contract can be carried out.
2. Prevent re-encampment for a period of ten years to assure that at least 80% of the new plantings will survive at the end of this monitoring and reporting period so that the City can close out the environmental agency regulatory permits.
3. Provide a safe environment for Bureau of Environment & Facilities staff to maintain the park spaces, plants and walkways with regular trash collection, weeding, pruning etc. for the seven years following close out of the contractor's maintenance and warranty period.
4. Provide a safe environment for consultants to perform the monitoring and reporting required over a period of ten years.
5. Allow the City to finally close out the environmental regulatory agency permits.
6. Provide a safe space to re-activate the park into a positive community resource, with safe and engaging play, as well as educational opportunities for neighborhood children.
7. Restore access to the greenway trail system between Lake Merritt and continuing south of Laney College.
8. Provide a lush and peaceful natural environment in which all may enjoy observing wildlife activities that also support good mental and physical health.
9. Restore the park to its rightful public uses, and community benefits.
10. Park to be closed at night. Anticipated hours of operation to be May – October 8:30am – 6:30pm; November – April 8:30am – 4:30pm.
11. Signage to include “no trespassing” to permit Oakland Police to remove unhoused who might be refusing to leave before park gates are locked for the night.

RECOMMENDATION

Staff endorses the Parks and Recreation Advisory Commission recommend approval of the proposed Minor Conditional Use Permit for fence enclosure of the entire Peralta Park project as described in the attached Exhibit B. Without full enclosure of the park, the City will not be able to meet the legal requirements of its environmental permits, and further deterioration of this community resource and wonderful wetland habitat will continue unimpeded for the foreseeable future.

Respectfully submitted,

 (Signature)

Prepared by:
Rebecca Darr
OPW Project Manager

 (Signature)

Approved by:
Calvin Hao
Acting PGM Division Manager

 (Signature)

Approved by:
Quincy Williams
Assistant Capital Improvement Projects Coordinator, OPRYD



Harith Aleem (Jan 31, 2024 20:01 PST) (Signature)

Approved by:
Harith Aleem
Interim Assistant Director, OPRYD

Identification of Support Documents:

Attachments: Exhibit A – *Project Location Maps*
Exhibit B – *Current Conditions & Design Presentation*

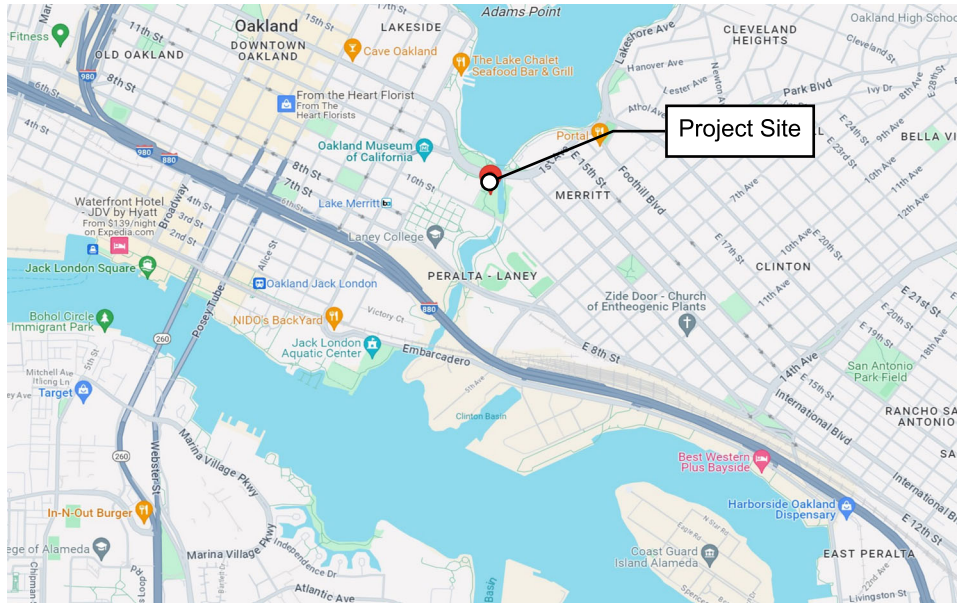
EXHIBIT A: PERALTA PARK FENCE PROJECT LOCATION MAPS



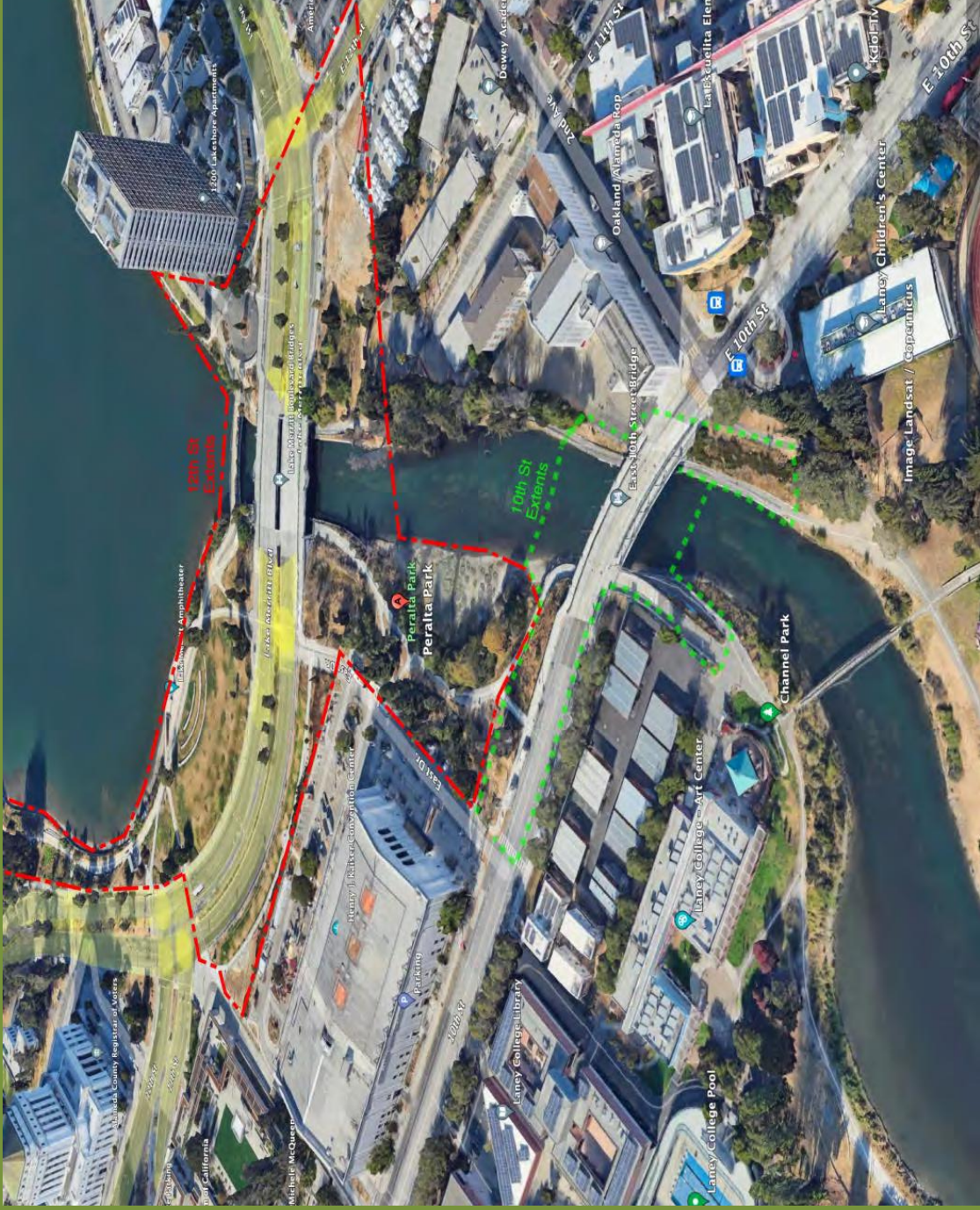

12th & 10th STREET BRIDGES

PERMIT MITIGATION REQUIREMENTS & PROPOSED FENCE ENCLOSURE PRAC Meeting 02/14/24

Recap of Issues Covered in Inter-Agency Meetings & with Neighboring Institutions in Fall of 2023

The following items were discussed and recognized:

1. Adverse impacts on the City's services and infrastructure, its citizens and open space resources resulting from unhoused encampments.
2. Increased need for emergency interventions by Fire Department, Police Department & Emergency Medical Services
3. Unsecured sites will inevitably incur new encampments with the same need for housing, safety and cleaning. The City has cleaned and closed encampments at this site 9 times in the past two years. Currently it is facing the worst encampment to date and increased levels of violence.
4. Numerous community institutions in the area have been struggling to manage worsening issues of homelessness and violence: Laney College, Oakland Museum of Contemporary Art, Oakland Universal School District, Oakland Chinatown Improvement Council, and Orton Development of the Kaiser Convention Center.

12th & 10th Street Bridges Encampment Closures & Deep Cleaning Efforts Over Past Two Years

LOCATION	OPERATION NOTES	OPERATION START DATE	OPERATION END DATE
Peralta Park	Deep Cleaning	8/10/2023	8/10/2023
Lake Merritt Blvd Underpass Near Peralta Park	Closure	12/5/2022	12/6/2022
Peralta Park	Closure	12/5/2022	12/6/2022
Peralta Park	Closure	6/20/2022	6/20/2022
Peralta Park	Closure	5/24/2022	5/24/2022
Peralta Park	Closure	3/30/2022	3/31/2022
Peralta Park	Deep Cleaning at Peralta Channel Park; Old LMCC Site/Adjacent to Henry J. Kaiser	1/24/2022	1/24/2022
Lake Merritt Blvd Underpass Near Peralta Park	Deep Cleaning at Peralta Channel Park; Old LMCC Site/Adjacent to Henry J. Kaiser underpasses included	12/8/2021	12/9/2021
Peralta Park	Deep Cleaning at Peralta Channel Park; Old LMCC Site/Adjacent to Henry J. Kaiser underpasses included	12/8/2021	12/9/2021

12th & 10th Street Bridges

Environmental Regulatory Agency Permits Closeout

Capital Contract Requirements

The City currently has 6 regulatory permits that remain open and incomplete from these 3 agencies:

- US Army Corps of Engineers
- SF Regional Water Quality Control Board
- California Department of Fish & Wildlife

Delays in permit closure due to pandemic and park destruction by encampments and unhoused. In order to close these permits, the following items are required:

- Secured & Safe Site for Contractor Mobilization and Staging to Complete Permit Mitigation Requirements
- Secured & Safe Site for City Construction Management during Construction
- Secured & Safe Site for Contractor 3-Year Maintenance/Warranty Requirements
- Secured & Safe Site for OPW BOE 7-Year Maintenance Requirements
- Secured & Safe Site for 10-Year Environmental Monitoring & Reporting

12th & 10th Street Bridges Existing Conditions in Peralta Park and at 10th Street Ramp Entrance – 7/16/23



12th & 10th Street Bridges
Existing Conditions in Peralta Park & Bike/Walkways
7/16/23



12th & 10th Street Bridges
Existing Conditions in Peralta Park & Bike/Walkways
7/16/23



12th & 10th Street Bridges
Existing Conditions Beneath 12th Street Bridge From Lake
Merritt Side 8/30/23 – Site Impassable for Public



Peralta
Park
New Fence
Extends
(945 LF) to
Provide
Safety &
Security
Needed to
Close
Permits &
Prevent
New
Camps



12th & 10th Street Bridges Pictures of Proposed New 8'-High Steel Picket Fence as Currently Installed



Photo of fence in February 2022 looking north from within Peralta Park

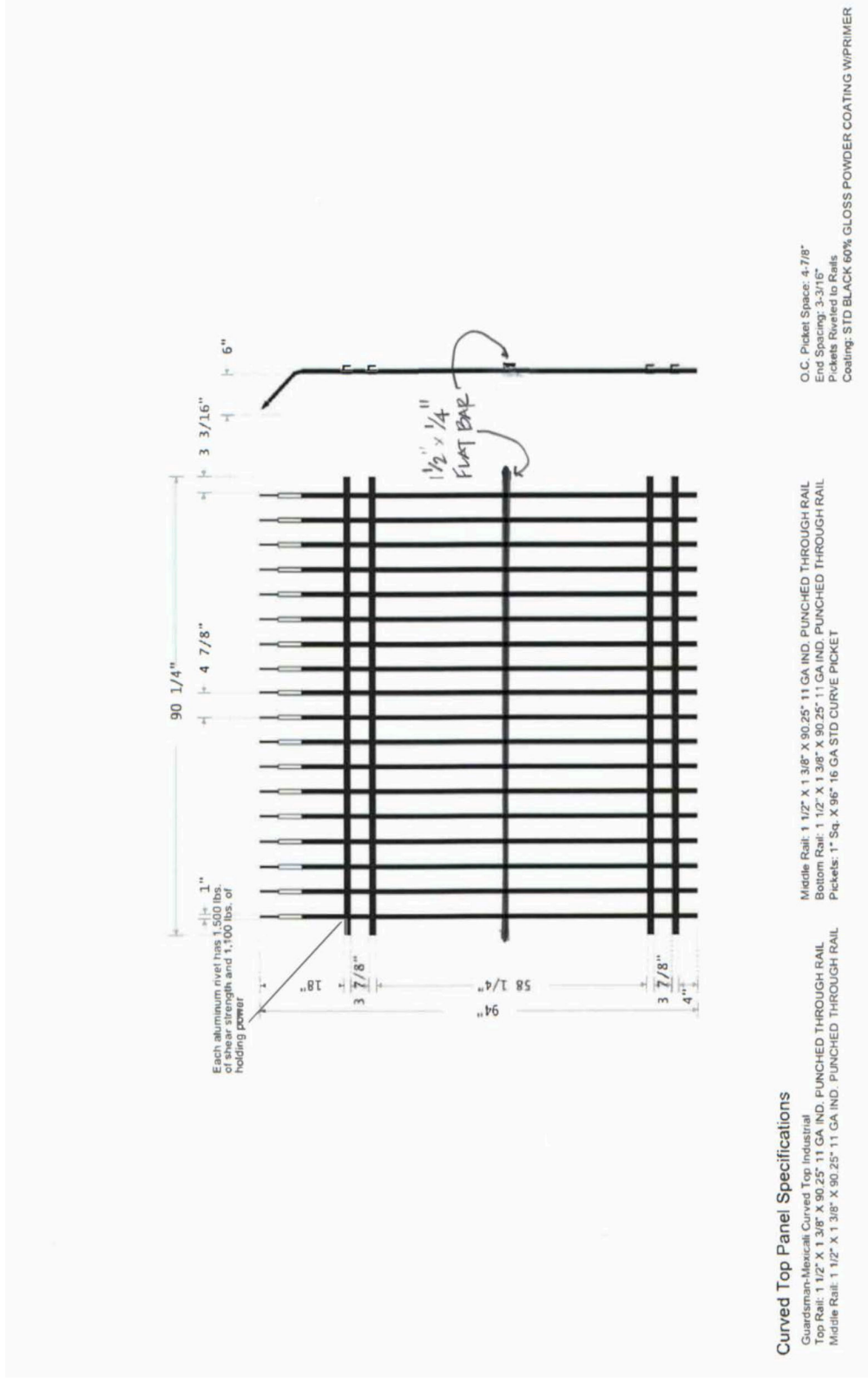

Photo of fence in February 2022 taken from 10th St. Bridge

12th & 10th Street Bridges

Proposed New 8'-High Steel Picket Fence

Fabrication Drawings



12th & 10th Street Bridges

Proposed New 8'-High Steel Picket Fence

Fabrication Drawings

