

Case File Number: PLN16-399

February 1, 2017

Location:	The Public Right-of-Way Adjacent to 1301 90th Ave. (See map on reverse)
Assessor Parcel Numbers:	Nearest adjacent lot (042 427001500)
Proposal:	To establish a telecommunications facility, to enhance existing services, by attaching an antenna and equipment to an existing wooden utility pole located in the public right-of-way (sidewalk). The 37' wooden utility pole is existing.
Applicant:	Extenet Systems (California) LLC. (for T-Mobile USA, INC)
Contact Person/ Phone Number:	Ana Gomez (913) 458-9148
Owner:	Joint Pole Authority (JPA) including PG&E
Case File Number:	PLN16-399
Planning Permits Required:	Major Design Review to install a wireless Telecommunication Macro Facility on a PG&E replacement pole located in RD-1 Zone.
General Plan:	Detached Unit Residential
Zoning:	RD-1 Detached Unit Residential Zone.
Environmental Determination:	Exempt, Section 15303 of the State CEQA Guidelines; New construction or conversion of small structures. Exempt, Section 15183 of the State CEQA Guidelines; Projects consistent with a Community Plan, General Plan or Zoning.
Historic Status:	Not a Potential Designated Historic Property; Survey rating: n/a
City Council District:	7
Finality of Decision:	Appealable to City Council within 10 Days
For Further Information:	Contact case planner Danny Thai at (510) 238-3584 or dthai@oaklandnet.com

SUMMARY

The project applicant (Extenet Systems) is proposing to install a wireless telecommunication facility on a PG&E utility pole located in the public right-of-way near 1301 90th Avenue. The project involves the installation of one canister antenna on an existing 37' tall wood utility pole. The canister antenna would measure 23.5" long and 7.9" in diameter at the height of 18' and two radio units (7.9" tall, 7.9" wide and 3.9" depth) mounted at the height of 10'-6" and 13'-11" above ground . The proposed antenna and associated related equipment are compatible with the PG&E utility pole. The proposed antenna would be extended toward the street and painted to match the pole. As a result, the proposed telecommunication facility is an appropriate location and would not significantly increase negative visual impacts to adjacent neighboring residential properties. The project meets all the required findings for approval of the project. Staff recommends approval, subject to the conditions described in this report.

CITY OF OAKLAND PLANNING COMMISSION

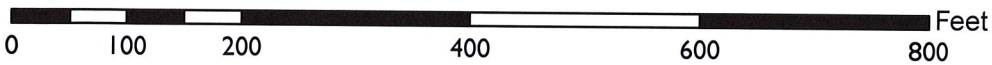

Case File: PLN16399

Applicant: Extenet Systems (California) LLC. (for T-Mobile USA, INC)

Address: The Public Right-of-Way Adjacent to 1301 90th Avenue

Zone: RD-1

BACKGROUND

For several years in the City of Oakland, telecommunications carriers have proposed facility installation within the public right-of-way, instead of private property. These facilities typically consist of antennas and associated equipment attached to utility poles or street light poles. Poles are often replaced with replicas for technical purposes. The main purpose is to enhance existing service, given increasing technological demands for bandwidth, through new technology and locational advantages. The City exercises zoning jurisdiction over such projects in response to a 2009 State Supreme Court case decision (*Sprint v. Palos Verdes Estates*). Under the Planning Code, utility or joint pole authority (JPA) sites are classified by staff as “Macro Facilities,” and street light pole sites (lamps, not traffic signals) as “Monopole Facilities.” For JPA poles, only Design Review approval may be required, as opposed to Design Review and a Conditional Use Permit, for example. For non-JPA pole sites, such as City light poles, projects also require review by the City’s Public Works Agency (PWA) and Real Estate Division and involve other considerations such as impacts to historical poles. The PWA may also review projects involving street lights. In either case, the practice has been to refer all such projects to the Planning Commission for decision when located in or near a residential zone.

Several projects for new DAS (distributed antenna services) facilities have come before the Planning Commission for a decision and have been installed throughout the Oakland Hills. Some applications have been denied due to view obstructions or propinquity to residences. Improved practices for the processing of all types of sites incorporating Planning Commission direction have been developed as a result. Conditions of approval typically attach requirements such as painting and texturing of approved components to more closely match utility poles in appearance. Approvals do not apply to any replacement project should the poles be removed for any reason. As with sites located on private property, the Federal Government precludes cities from denying an application on the basis of emissions concerns if a satisfactory emissions report is submitted. More recent Federal changes have streamlined the process to service existing facilities.

Currently, telecommunications carriers are in the process of attempting to deploy “small cell sites.” These projects also involve attachment of antennas and equipment at public right-of-way facilities such as poles or lights for further enhancement of services. However, components are now somewhat smaller in size than in the past. Also, sites tend to be located in flatland neighborhoods and Downtown where view obstructions are less likely to be an issue. Good design and placement are given full consideration nonetheless, especially with the greater presence of historic structures in Downtown. Additionally, given the sheer multitude of applications, and, out of consideration for Federal requirements for permit processing timelines, staff may develop alternatives to traditional staffing and agendas.

Limitations on Local Government Zoning Authority under the Telecommunications Act of 1996

Section 704 of the Telecommunications Act of 1996 (TCA) provides federal standards for the siting of “Personal Wireless Services Facilities.” “Personal Wireless Services” include all commercial mobile services (including personal communications services (PCS), cellular radio mobile services, and paging); unlicensed wireless services; and common carrier wireless exchange access services. Under Section 704, local zoning authority over personal wireless

services is preserved such that the FCC is prevented from preempting local land use decisions; however, local government zoning decisions are still restricted by several provisions of federal law. Specifically:

- Under Section 253 of the TCA, no state or local regulation or other legal requirement can prohibit or have the effect of prohibiting the ability of any entity to provide any interstate or intrastate telecommunications service.
- Further, Section 704 of the TCA imposes limitations on what local and state governments can do. Section 704 prohibits any state and local government action which unreasonably discriminates among personal wireless providers. Local governments must ensure that its wireless ordinance does not contain requirements in the form of regulatory terms or fees which may have the “effect” of prohibiting the placement, construction, or modification of personal wireless services.
- Section 704 also preempts any local zoning regulation purporting to regulate the placement, construction and modification of personal wireless service facilities on the basis, either directly or indirectly, on the environmental effects of radio frequency emissions (RF) of such facilities, which otherwise comply with Federal Communications Commission (FCC) standards in this regard (See 47 U.S.C. Section 332(c)(7)(B)(iv)(1996)). This means that local authorities may not regulate the siting or construction of personal wireless facilities based on RF standards that are more stringent than those promulgated by the FCC.
- Section 704 mandates that local governments act upon personal wireless service facility siting applications to place, construct, or modify a facility within a reasonable time (See 47 U.S.C.332(c)(7)(B)(ii) and the FCC Shot Clock ruling setting forth “reasonable time” standards for applications deemed complete).
- Section 704 also mandates that the FCC provide technical support to local governments in order to encourage them to make property, rights-of-way, and easements under their jurisdiction available for the placement of new spectrum-based telecommunications services. This proceeding is currently at the comment stage.

For more information on the FCC’s jurisdiction in this area, contact Steve Markendorff, Chief of the Broadband Branch, Commercial Wireless Division, Wireless Telecommunications Bureau, at (202) 418-0640 or e-mail "smarkend@fcc.gov."

PROPERTY DESCRIPTION

The existing tall PG&E utility pole is located in the City of Oakland public right-of-way and is 20’-10” away from an adjacent one-story residential building located at 1301 90th Avenue.

PROJECT DESCRIPTION

The applicant proposes to install a wireless telecommunication facility on a PG&E utility pole located in the public right-of-way near 1301 90th Avenue. The project involves the installation

of one canister antenna on an existing 37' tall wood utility pole. The canister antenna would measure 23.5" long and 7.9" in diameter at the height of 18' and two radio units (7.9" tall, 7.9" wide and 3.9" depth) mounted at the height of 10'-6" and 13'-11" above ground (See Attachment C).

GENERAL PLAN ANALYSIS

The site is classified as Detached Unit Residential per the Oakland General Plan's Land Use and Transportation Element (LUTE). This classification is intended to create, maintain, and enhance residential areas characterized by detached, single unit structures. According to the LUTE, "Future development within this classification should be primarily residential in character with appropriate allowances for schools and other small scale civic institutions."

The proposed unmanned wireless telecommunication facility will not adversely affect and detract from the characteristics of the neighborhood. The proposed new pole is similar to other utility poles within the same block. The proposed antenna and associated related equipment are compatible with the typical utilities located on these poles. As a result, the proposal is an appropriate location for the proposed telecommunication facility and would not significantly increase negative visual impacts to adjacent neighboring residential properties

ZONING ANALYSIS

The proposed telecommunications facility is located within the RD-1 Detached Unit Residential Zone. The intent of the RD-1 Zone is to create, maintain and enhance residential areas characterized by a detached, single-unit structures.

Section 17.136.040 and 17.128.070 of the City of Oakland Planning Code requires a Major Design Review permit for Macro Telecommunication facilities that are attached to utility poles in the RD-1 Zone or that are located within one hundred (100) feet of the boundary of any residential zone. Special findings are also required for Design Review approval to ensure that the facility is concealed to the greatest extent possible. The project design is discussed later in the *Key Issues and Impacts* section of this report, and the required findings for Major Design Review are listed and included in staff's evaluation later in the *Findings* section of this report.

ENVIRONMENTAL DETERMINATION

The California Environmental Quality Act (CEQA) Guidelines lists the projects that qualify as categorical exemptions from environmental review. The proposed project is categorically exempt from the environmental review requirements pursuant to Section 15303 for installation of telecommunication facility (small structure) on a new proposed public utility pole. Furthermore, the project is also exempt per Section 15183, for projects consistent with a community plan, general plan or zoning.

KEY ISSUES AND IMPACTS**Project Site**

Section 17.128.070A of the City of Oakland Telecommunications Regulations requires that new macro telecommunications facilities shall generally be designed according to the following development guidelines, followed by staff's analysis in relation to this application:

- A. The Macro Facilities shall be located on existing buildings, poles or other existing support structures, or shall be post mounted.
- B. The equipment shelter or cabinet must be concealed from public view or made compatible with the architecture of the surrounding structures or placed underground. The shelter or cabinet must be regularly maintained.
- C. Macro Facilities may exceed the height limitation specified for all zones but may not exceed fifteen (15) feet above the roof line or parapet. Placement of an antenna on a nonconforming structure shall not be considered to be an expansion of the nonconforming structure.
- D. Ground post mounted Macro Facilities must not exceed seventeen (17) feet to the top of the antenna.
- E. The applicant shall submit written documentation demonstrating that the emissions from the proposed project are within the limits set by the Federal Communications Commission.

The facility involves attachment to an existing utility pole hosting power lines and a City street light. Recommended conditions of approval require painting and texturing the antenna matte silver and all components matte brown to match the appearance of the wooden utility pole and power line posts. The proposal does not involve attachment to a roofed structure, exceed fifteen (15) feet above the roof line of the adjacent property, or involve a ground post mounted facility. A satisfactory emissions report has been submitted and is attached to this report (See Attachment F).

Project Site

Section 17.128.110 of Oakland's Telecommunication Regulations requires that new wireless facilities shall generally be located on designated properties or facilities in the following order of ranked preference:

- A. Co-located on an existing structure or facility with existing wireless antennas.
- B. City owned properties or other public or quasi-public facilities.
- C. Existing commercial or industrial structures in non-residential zones (excluding all HBX Zones and the D-CE3 and D-C-4 Zones).
- D. Existing commercial or industrial structures in residential zones, HBX Zones, or the D-CE-3 or D-CE-4 Zones.
- E. Other non-residential uses in residential zones, HBX Zones, or the D-CE-3 or D-CE-4 Zones.
- F. Residential uses in non-residential zones. (excluding all HBX Zones and the D-CE-3 and D-CE-4 Zones).
- G. Residential uses in residential zones, HBX Zones, or the D-CE-3 or D-CE-4 Zones.

Facilities sited on an A, B or C ranked preferences do not require a site alternatives analysis. Facilities proposing to locate on a D through G ranked preference, inclusive, must submit a site alternatives analysis as part of the required application materials. Since the proposed project involves the replacement of existing wood utility pole with a new PG&E pole within the public right-of-way and installation of a new antenna and radio units within RM-2 Zone, the proposed project meets the B and hence a site alternatives analysis is not required. However, the applicant submitted a site alternatives analysis (See Attachment E).

Extenet System considered alternative sites on other utility poles in this area, but none of these are as desirable from a service coverage or aesthetics perspective (See Attachment E). The proposed location is approximately equidistant from other Distributed Antenna System (DAS) nodes proposed in the surrounding area so that service coverage can be evenly distributed. The staff has reviewed the applicant's alternative sites analysis (See Attachment E) and determined that the site selected conforms to the telecommunication regulation requirements. Furthermore, staff agrees that the proposed site is the most preferable location for the new telecommunications facility.

Project Design

Section 17.128.120 of the City of Oakland Telecommunications Regulations requires that new wireless facilities shall generally be designed in the following order of ranked preference:

- A. Building or structure mounted antennas completely concealed from view.
- B. Building or structure mounted antennas set back from roof edge, not visible from public right-of-way.
- C. Building or structure mounted antennas below roof line (facade mount, pole mount) visible from public right-of-way, painted to match existing structure.
- D. Building or structure mounted antennas above roof line visible from public right-of-way.
- E. Monopoles.
- F. Towers.

Facilities designed to meet an A and B ranked preference do not require a site design alternatives analysis. Facilities designed to meet C through F ranked preference, inclusive, must submit a site design alternatives analysis as part of the required application materials. A site design alternatives analysis shall, at a minimum, consist of:

Written evidence must indicate why each higher preference design alternative cannot be used. Such evidence shall be in sufficient detail that independent verification could be obtained if required by the City of Oakland Zoning Manager. Evidence should indicate if the reason an alternative was rejected was technical (e.g. incorrect height, interference from existing RF sources, inability to cover required area) or for other concerns (e.g. inability to provide utilities, construction or structural impediments).

Since the proposed project does not meet preference A and B, a site design alternatives analysis is required. The proposal most closely conforms to 'C' (structure mounted antennas below roof line visible from public right-of-way), and the applicant has submitted a satisfactory site design alternatives analysis (See Attachment E).

Extenet System evaluated whether the equipment could be undergrounded but unfortunately this is not possible because there is insufficient right-of-way space for the necessary equipment access and the equipment would be compromised by rainwater saturation. The proposed antenna design is approximately equidistant from other DAS nodes proposed in the surrounding area so that service coverage can be evenly distributed. The proposed design is a good option because the facility is located where a signal can be adequately propagated without obstruction, which could not have been the case if the antenna was located on a building or concealed. The proposed screened antenna and associated equipment will be concealed to the extent possible by painting to match the wooden utility pole. The proposal would not significantly increase negative visual impacts to adjacent neighboring residential properties.

Project Radio Frequency Emissions Standards

Section 17.128.130 of the City of Oakland Telecommunication Regulations requires that the applicant submits the following verifications including requests for modifications to existing facilities:

a. The Telecommunications regulations require that the applicant submit written documentation demonstrating that the emission from the proposed project are within the limits set by the Federal Communications Commission. In the document (attachment B) prepared by Hammett & Edison Consulting Engineers Inc. the proposed project was evaluated for compliance with appropriate guidelines limiting human exposure to radio frequency electromagnetic fields. According to the report on the proposal, the project will comply with the prevailing standards for limiting public exposure to radio frequency energy and, therefore, the proposed site will operate within the current acceptable thresholds as established by the Federal Government or any such agency that may be subsequently authorized to establish such standards.

b. Prior to final building permit sign off, an RF emissions report indicating that the site is actually operating within the acceptable thresholds as established by the Federal government or any such agency who may be subsequently authorized to establish such standards.

The RF emissions report, prepared by Hammett & Edison Consulting Engineers Inc was submitted with the initial application (See Attachment F). The report states that the proposed project will comply with the prevailing standards for limiting public exposure to radio frequency energy, and therefore, will not cause a significant impact on the environment. Furthermore, staff recommends that before the final building permit sign off, the applicant submits a certified RF emissions report stating that the facility is operating within acceptable thresholds established by the federal regulatory agency.

CONCLUSION

The proposed project meets all of the required findings for Design Review approval. The proposal will provide essential telecommunication services to the community and the City of Oakland at large. It will also be available to emergency services such as police, fire department

and emergency response teams. Staff requested that the applicant provides a “slimmer” design consisting of tucking the antenna in closer to the pole. The applicant responded that this was not feasible due to the technological requirements by the Public Utilities Commission (See Attachment G). Staff, therefore, finds the proposal to provide an essential service with a least-intrusive possible design. Draft conditions of approval stipulate that the components be painted and textured to match the wooden utility pole in appearance for camouflaging.

RECOMMENDATIONS:

1. Affirm staff’s environmental determination
2. Approve Major Design Review application, subject to the attached findings and conditions of approval.

Prepared by:

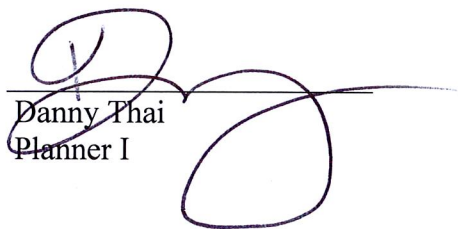
Danny Thai
Planner I

Reviewed by:

Scott Miller
Zoning Manager

Approved for forwarding to the
City Planning Commission

Darin Ranelletti, Interim Director
Bureau of Planning and Building

ATTACHMENTS:

- A. Findings
- B. Conditions of Approval
- C. Plans dated October 27, 2016
- D. Applicant’s Photo-Simulations
- E. Site Alternatives Analysis/Site Design Alternatives Analysis dated October 19, 2016
- F. RF Emissions Report by Hammett & Edison, Inc. dated October 10, 2016
- G. CPUC Compliance Letter dated December 29, 2016
- H. Applicant-proof of public notification posting

FINDINGS FOR APPROVAL

This proposal meets the required findings under Section 17.136.050 (B) (Non-Residential Design Review criteria); and, 17.128.060(B) (Telecommunications Macro Facilities 17.128.070 (B), as set forth below. Required findings are shown in **bold** type; reasons proposal satisfies them are shown in normal type.

17.136.050(B) – NONRESIDENTIAL DESIGN REVIEW CRITERIA:

1. That the proposal will help achieve or maintain a group of facilities which are well related to one another and which, when taken together, will result in a well-composed design, with consideration given to site, landscape, bulk, height, arrangement, texture, materials, colors, and appurtenances; the relation of these factors to other facilities in the vicinity; and the relation of the proposal to the total setting as seen from key points in the surrounding area. Only elements of design which have some significant relationship to outside appearance shall be considered, except as otherwise provided in Section 17.136.060;

The project involves the installation of a new wireless Telecommunication facility on new a tall wood PG&E utility pole located in the public right-of-way. The attachment of a small antenna and equipment to a non-historic utility pole, painted and texturized to match the wooden pole and power line posts in appearance for camouflaging will be the least intrusive design.

2. That the proposed design will be of a quality and character which harmonizes with, and serves to protect the value of, private and public investments in the area;

The pole will be similar to other wood PG&E poles. The proposed antennas and radio units will be typical of the utility equipment found on poles: located high up on the pole, oriented toward the street and painted to match with the new replaced PG&E utility pole. Therefore, the facility will not adversely affect and detract from residential characteristics of the neighborhood.

3. That the proposed design conforms in all significant respects with the Oakland General Plan and with any applicable design review guidelines or criteria, district plan, or development control map which have been adopted by the Planning Commission or City Council.

The site is classified as Detached Unit Residential per the Oakland General Plan's Land Use and Transportation Element (LUTE). This classification is intended to create, maintain, and enhance residential areas characterized by detached, single unit structures. According to the LUTE, "Future development within this classification should be primarily residential in character with appropriate allowances for schools and other small scale civic institutions."

Section 17.128.120 of the City of Oakland Telecommunications Regulations describes the design criteria for wireless facilities. In general, these facilities should either be concealed from view or not visible from the public right of way. Since the project did not meet either ranked criteria, but did meet criteria D as also described in 17.128.120, an alternative site design study needed to be undertaken. The analysis shows that the proposed new pole is similar to other utility poles within the same block. The proposed antenna and associated related equipment are compatible with and typical of the utility equipment on these poles, the proposed antenna will be extended toward the

street and away from the home at 1301 90th Avenue, and painted to match the pole. As result, the proposal is consistent telecommunication regulation requirements, in an appropriate location, and of an appropriate design that would not significantly increase negative visual impacts to adjacent neighboring residential properties

17.128.070(B) DESIGN REVIEW CRITERIA FOR MACRO FACILITIES

1. Antennas should be painted and/or textured to match the existing structure:

The antenna will be painted and texturized matte silver to match the power line posts in appearance for camouflaging to reduce visual impact as required by conditions of approval.

2. Antennas mounted on architecturally significant structures or significant architectural details of the building should be covered by appropriate casings which are manufactured to match existing architectural features found on the building:

The proposed antenna and equipment will not be mounted onto an architecturally significant structure but a proposed new wooden utility pole.

3. Where feasible, antennas can be placed directly above, below or incorporated with vertical design elements of a building to help in camouflaging:

The proposal antennas will be placed above and vertically in line with, the proposed utility pole and painted to match pole to blend with the surroundings.

4. Equipment shelters or cabinets shall be screened from the public view by using landscaping, or materials and colors consistent with surrounding backdrop:

The associated equipment cabinets will be located within a shroud attached to a replaced utility pole and painted to match the proposed wooden pole to minimize visual impacts on the neighboring properties.

5. Equipment shelters or cabinets shall be consistent with the general character of the area.

See above finding # 4

6. For antennas attached to the roof, maintain a 1:1 ratio for equipment setback; screen the antennas to match existing air conditioning units, stairs, or elevator towers; avoid placing roof mounted antennas in direct line with significant view corridors.

N/A

7. That all reasonable means of reducing public access to the antennas and equipment has been made, including, but not limited to, placement in or on buildings or structures, fencing, anti-climbing measures and anti-tampering devices.

The proposed screened antenna will be mounted at the height of 18' on a existing PG&E utility pole and will not be accessible to the public due to its location. The radio units' equipment will be attached to the pole 10'-6" and 13'-11" above the ground. The lowest height of the facility's equipment is 7'-4" above the ground.

ATTACHMENT B

CONDITIONS OF APPROVAL
PLN16-399

STANDARD CONDITIONS:

1. Approved Use

The project shall be constructed and operated in accordance with the authorized use as described in the approved application materials, **PLN16-399** and submitted plans **dated** October 27, 2016, as amended by the following conditions of approval and mitigation measures, if applicable (“Conditions of Approval” or “Conditions”).

2. Effective Date, Expiration, Extensions and Extinguishment

This Approval shall become effective immediately, unless the Approval is appealable, in which case the Approval shall become effective in ten calendar days unless an appeal is filed. Unless a different termination date is prescribed, this Approval shall expire **two calendar years** from the Approval date, or from the date of the final decision in the event of an appeal, unless within such period all necessary permits for construction or alteration have been issued, or the authorized activities have commenced in the case of a permit not involving construction or alteration. Upon written request and payment of appropriate fees submitted no later than the expiration date of this Approval, the Director of City Planning or designee may grant a one-year extension of this date, with additional extensions subject to approval by the approving body. Expiration of any necessary building permit or other construction-related permit for this project may invalidate this Approval if said Approval has also expired. If litigation is filed challenging this Approval, or its implementation, then the time period stated above for obtaining necessary permits for construction or alteration and/or commencement of authorized activities is automatically extended for the duration of the litigation.

3. Compliance with Other Requirements

The project applicant shall comply with all other applicable federal, state, regional, and local laws/codes, requirements, regulations, and guidelines, including but not limited to those imposed by the City’s Bureau of Building, Fire Marshal, and Public Works Department. Compliance with other applicable requirements may require changes to the approved use and/or plans. These changes shall be processed in accordance with the procedures contained in Condition #4.

4. Minor and Major Changes

- a. Minor changes to the approved project, plans, Conditions, facilities, or use may be approved administratively by the Director of City Planning.
- b. Major changes to the approved project, plans, Conditions, facilities, or use shall be reviewed by the Director of City Planning to determine whether such changes require

submittal and approval of a revision to the Approval by the original approving body or a new independent permit/approval. Major revisions shall be reviewed in accordance with the procedures required for the original permit/approval. A new independent permit/approval shall be reviewed in accordance with the procedures required for the new permit/approval.

5. Compliance with Conditions of Approval

- a. The project applicant and property owner, including successors, (collectively referred to hereafter as the "project applicant" or "applicant") shall be responsible for compliance with all the Conditions of Approval and any recommendations contained in any submitted and approved technical report at his/her sole cost and expense, subject to review and approval by the City of Oakland.
- b. The City of Oakland reserves the right at any time during construction to require certification by a licensed professional at the project applicant's expense that the as-built project conforms to all applicable requirements, including but not limited to, approved maximum heights and minimum setbacks. Failure to construct the project in accordance with the Approval may result in remedial reconstruction, permit revocation, permit modification, stop work, permit suspension, or other corrective action.
- c. Violation of any term, Condition, or project description relating to the Approval is unlawful, prohibited, and a violation of the Oakland Municipal Code. The City of Oakland reserves the right to initiate civil and/or criminal enforcement and/or abatement proceedings, or after notice and public hearing, to revoke the Approval or alter these Conditions if it is found that there is violation of any of the Conditions or the provisions of the Planning Code or Municipal Code, or the project operates as or causes a public nuisance. This provision is not intended to, nor does it, limit in any manner whatsoever the ability of the City to take appropriate enforcement actions. The project applicant shall be responsible for paying fees in accordance with the City's Master Fee Schedule for inspections conducted by the City or a City-designated third-party to investigate alleged violations of the Approval or Conditions.

6. Signed Copy of the Approval/Conditions

A copy of the Approval letter and Conditions shall be signed by the project applicant, attached to each set of permit plans submitted to the appropriate City agency for the project, and made available for review at the project job site at all times.

7. Blight/Nuisances

The project site shall be kept in a blight/nuisance-free condition. Any existing blight or nuisance shall be abated within 60 days of approval, unless an earlier date is specified elsewhere.

8. Indemnification

- a. To the maximum extent permitted by law, the project applicant shall defend (with counsel acceptable to the City), indemnify, and hold harmless the City of Oakland, the Oakland City Council, the Oakland Redevelopment Successor Agency, the Oakland

City Planning Commission, and their respective agents, officers, employees, and volunteers (hereafter collectively called "City") from any liability, damages, claim, judgment, loss (direct or indirect), action, causes of action, or proceeding (including legal costs, attorneys' fees, expert witness or consultant fees, City Attorney or staff time, expenses or costs) (collectively called "Action") against the City to attack, set aside, void or annul this Approval or implementation of this Approval. The City may elect, in its sole discretion, to participate in the defense of said Action and the project applicant shall reimburse the City for its reasonable legal costs and attorneys' fees.

- b. Within ten (10) calendar days of the filing of any Action as specified in subsection (a) above, the project applicant shall execute a Joint Defense Letter of Agreement with the City, acceptable to the Office of the City Attorney, which memorializes the above obligations. These obligations and the Joint Defense Letter of Agreement shall survive termination, extinguishment, or invalidation of the Approval. Failure to timely execute the Letter of Agreement does not relieve the project applicant of any of the obligations contained in this Condition or other requirements or Conditions of Approval that may be imposed by the City.

9. Severability

The Approval would not have been granted but for the applicability and validity of each and every one of the specified Conditions, and if one or more of such Conditions is found to be invalid by a court of competent jurisdiction this Approval would not have been granted without requiring other valid Conditions consistent with achieving the same purpose and intent of such Approval.

10. Special Inspector/Inspections, Independent Technical Review, Project Coordination and Monitoring

The project applicant may be required to cover the full costs of independent third-party technical review and City monitoring and inspection, including without limitation, special inspector(s)/inspection(s) during times of extensive or specialized plan-check review or construction, and inspections of potential violations of the Conditions of Approval. The project applicant shall establish a deposit with the Bureau of Building, if directed by the Building Official, Director of City Planning, or designee, prior to the issuance of a construction-related permit and on an ongoing as-needed basis.

11. Public Improvements

The project applicant shall obtain all necessary permits/approvals, such as encroachment permits, obstruction permits, curb/gutter/sidewalk permits, and public improvement (“p-job”) permits from the City for work in the public right-of-way, including but not limited to, streets, curbs, gutters, sidewalks, utilities, and fire hydrants. Prior to any work in the public right-of-way, the applicant shall submit plans for review and approval by the Bureau of Planning, the Bureau of Building, and other City departments as required. Public improvements shall be designed and installed to the satisfaction of the City.

12. Regulatory Permits and Authorizations from Other Agencies

Requirement: The project applicant shall obtain all necessary regulatory permits and authorizations from applicable resource/regulatory agencies including, but not limited to, the Regional Water Quality Control Board, Bay Area Air Quality Management District, Bay Conservation and Development Commission, California Department of Fish and Wildlife, U. S. Fish and Wildlife Service, and Army Corps of Engineers and shall comply with all requirements and conditions of the permits/authorizations. The project applicant shall submit evidence of the approved permits/authorizations to the City, along with evidence demonstrating compliance with any regulatory permit/authorization conditions of approval.

When Required: Prior to activity requiring permit/authorization from regulatory agency

Initial Approval: Approval by applicable regulatory agency with jurisdiction; evidence of approval submitted to Bureau of Planning

Monitoring/Inspection: Applicable regulatory agency with jurisdiction

13. Graffiti Control

Requirement:

- a. During construction and operation of the project, the project applicant shall incorporate best management practices reasonably related to the control of graffiti and/or the mitigation of the impacts of graffiti. Such best management practices may include, without limitation:
 - i. Installation and maintenance of landscaping to discourage defacement of and/or protect likely graffiti-attracting surfaces.
 - ii. Installation and maintenance of lighting to protect likely graffiti-attracting surfaces.
 - iii. Use of paint with anti-graffiti coating.
 - iv. Incorporation of architectural or design elements or features to discourage graffiti defacement in accordance with the principles of Crime Prevention Through Environmental Design (CPTED).
 - v. Other practices approved by the City to deter, protect, or reduce the potential for graffiti defacement.
- b. The project applicant shall remove graffiti by appropriate means within seventy-two (72) hours. Appropriate means include the following:

- i. Removal through scrubbing, washing, sanding, and/or scraping (or similar method) without damaging the surface and without discharging wash water or cleaning detergents into the City storm drain system.
- ii. Covering with new paint to match the color of the surrounding surface.
- iii. Replacing with new surfacing (with City permits if required).

When Required: Ongoing

Initial Approval: N/A

Monitoring/Inspection: Bureau of Building

14. Construction-Related Air Pollution Controls (Dust and Equipment Emissions)

Requirement: The project applicant shall implement all of the following applicable air pollution control measures during construction of the project:

- a. Water all exposed surfaces of active construction areas at least twice daily. Watering should be sufficient to prevent airborne dust from leaving the site. Increased watering frequency may be necessary whenever wind speeds exceed 15 miles per hour. Reclaimed water should be used whenever feasible.
- b. Cover all trucks hauling soil, sand, and other loose materials or require all trucks to maintain at least two feet of freeboard (i.e., the minimum required space between the top of the load and the top of the trailer).
- c. All visible mud or dirt track-out onto adjacent public roads shall be removed using wet power vacuum street sweepers at least once per day. The use of dry power sweeping is prohibited.
- d. Pave all roadways, driveways, sidewalks, etc. within one month of site grading or as soon as feasible. In addition, building pads should be laid within one month of grading or as soon as feasible unless seeding or soil binders are used.
- e. Enclose, cover, water twice daily, or apply (non-toxic) soil stabilizers to exposed stockpiles (dirt, sand, etc.).
- f. Limit vehicle speeds on unpaved roads to 15 miles per hour.
- g. Idling times on all diesel-fueled commercial vehicles over 10,000 lbs. shall be minimized either by shutting equipment off when not in use or reducing the maximum idling time to five minutes (as required by the California airborne toxics control measure Title 13, Section 2485, of the California Code of Regulations). Clear signage to this effect shall be provided for construction workers at all access points.
- h. Idling times on all diesel-fueled off-road vehicles over 25 horsepower shall be minimized either by shutting equipment off when not in use or reducing the maximum idling time to five minutes and fleet operators must develop a written policy as required by Title 23, Section 2449, of the California Code of Regulations (“California Air Resources Board Off-Road Diesel Regulations”).
- i. All construction equipment shall be maintained and properly tuned in accordance with the manufacturer’s specifications. All equipment shall be checked by a certified mechanic and determined to be running in proper condition prior to operation.
- j. Portable equipment shall be powered by electricity if available. If electricity is not available, propane or natural gas shall be used if feasible. Diesel engines shall only be used if electricity is not available and it is not feasible to use propane or natural gas.

15. Archaeological and Paleontological Resources – Discovery During Construction

Requirement: Pursuant to CEQA Guidelines section 15064.5(f), in the event that any historic or prehistoric subsurface cultural resources are discovered during ground disturbing activities, all work within 50 feet of the resources shall be halted and the project applicant shall notify the City and consult with a qualified archaeologist or paleontologist, as applicable, to assess the significance of the find. In the case of discovery of paleontological resources, the assessment shall be done in accordance with the Society of Vertebrate Paleontology standards. If any find is determined to be significant, appropriate avoidance measures recommended by the consultant and approved by the City must be followed unless avoidance is determined unnecessary or infeasible by the City. Feasibility of avoidance shall be determined with consideration of factors such as the nature of the find, project design, costs, and other considerations. If avoidance is unnecessary or infeasible, other appropriate measures (e.g., data recovery, excavation) shall be instituted. Work may proceed on other parts of the project site while measures for the cultural resources are implemented.

In the event of data recovery of archaeological resources, the project applicant shall submit an Archaeological Research Design and Treatment Plan (ARDTP) prepared by a qualified archaeologist for review and approval by the City. The ARDTP is required to identify how the proposed data recovery program would preserve the significant information the archaeological resource is expected to contain. The ARDTP shall identify the scientific/historic research questions applicable to the expected resource, the data classes the resource is expected to possess, and how the expected data classes would address the applicable research questions. The ARDTP shall include the analysis and specify the curation and storage methods. Data recovery, in general, shall be limited to the portions of the archaeological resource that could be impacted by the proposed project. Destructive data recovery methods shall not be applied to portions of the archaeological resources if nondestructive methods are practicable. Because the intent of the ARDTP is to save as much of the archaeological resource as possible, including moving the resource, if feasible, preparation and implementation of the ARDTP would reduce the potential adverse impact to less than significant. The project applicant shall implement the ARDTP at his/her expense.

In the event of excavation of paleontological resources, the project applicant shall submit an excavation plan prepared by a qualified paleontologist to the City for review and approval. All significant cultural materials recovered shall be subject to scientific analysis, professional museum curation, and/or a report prepared by a qualified paleontologist, as appropriate, according to current professional standards and at the expense of the project applicant.

When Required: During construction

Initial Approval: N/A

Monitoring/Inspection: Bureau of Building

16. Human Remains – Discovery During Construction

Requirement: Pursuant to CEQA Guidelines section 15064.5(e)(1), in the event that human skeletal remains are uncovered at the project site during construction activities, all work shall immediately halt and the project applicant shall notify the City and the Alameda County Coroner. If the County Coroner determines that an investigation of the cause of death is required or that the remains are Native American, all work shall cease within 50 feet of the remains until appropriate arrangements are made. In the event that the remains are Native American, the City shall contact the California Native American Heritage Commission (NAHC), pursuant to subdivision (c) of section 7050.5 of the California Health and Safety Code. If the agencies determine that avoidance is not feasible, then an alternative plan shall be prepared with specific steps and timeframe required to resume construction activities. Monitoring, data recovery, determination of significance, and avoidance measures (if applicable) shall be completed expeditiously and at the expense of the project applicant.

When Required: During construction

Initial Approval: N/A

Monitoring/Inspection: Bureau of Building

17. Construction-Related Permit(s)

Requirement: The project applicant shall obtain all required construction-related permits/approvals from the City. The project shall comply with all standards, requirements and conditions contained in construction-related codes, including but not limited to the Oakland Building Code and the Oakland Grading Regulations, to ensure structural integrity and safe construction.

When Required: Prior to approval of construction-related permit

Initial Approval: Bureau of Building

Monitoring/Inspection: Bureau of Building

18. Hazardous Materials Related to Construction

Requirement: The project applicant shall ensure that Best Management Practices (BMPs) are implemented by the contractor during construction to minimize potential negative effects on groundwater, soils, and human health. These shall include, at a minimum, the following:

- a. Follow manufacture's recommendations for use, storage, and disposal of chemical products used in construction;
- b. Avoid overtopping construction equipment fuel gas tanks;
- c. During routine maintenance of construction equipment, properly contain and remove grease and oils;
- d. Properly dispose of discarded containers of fuels and other chemicals;
- e. Implement lead-safe work practices and comply with all local, regional, state, and federal requirements concerning lead (for more information refer to the Alameda County Lead Poisoning Prevention Program); and
- f. If soil, groundwater, or other environmental medium with suspected contamination is encountered unexpectedly during construction activities (e.g., identified by odor or

visual staining, or if any underground storage tanks, abandoned drums or other hazardous materials or wastes are encountered), the project applicant shall cease work in the vicinity of the suspect material, the area shall be secured as necessary, and the applicant shall take all appropriate measures to protect human health and the environment. Appropriate measures shall include notifying the City and applicable regulatory agency(ies) and implementation of the actions described in the City's Standard Conditions of Approval, as necessary, to identify the nature and extent of contamination. Work shall not resume in the area(s) affected until the measures have been implemented under the oversight of the City or regulatory agency, as appropriate.

When Required: During construction

Initial Approval: N/A

Monitoring/Inspection: Bureau of Building

19. Construction Days/Hours

Requirement: The project applicant shall comply with the following restrictions concerning construction days and hours:

- a. Construction activities are limited to between 7:00 a.m. and 7:00 p.m. Monday through Friday, except that pier drilling and/or other extreme noise generating activities greater than 90 dBA shall be limited to between 8:00 a.m. and 4:00 p.m.
- b. Construction activities are limited to between 9:00 a.m. and 5:00 p.m. on Saturday. In residential zones and within 300 feet of a residential zone, construction activities are allowed from 9:00 a.m. to 5:00 p.m. only within the interior of the building with the doors and windows closed. No pier drilling or other extreme noise generating activities greater than 90 dBA are allowed on Saturday.
- c. No construction is allowed on Sunday or federal holidays.

Construction activities include, but are not limited to, truck idling, moving equipment (including trucks, elevators, etc.) or materials, deliveries, and construction meetings held on-site in a non-enclosed area.

Any construction activity proposed outside of the above days and hours for special activities (such as concrete pouring which may require more continuous amounts of time) shall be evaluated on a case-by-case basis by the City, with criteria including the urgency/emergency nature of the work, the proximity of residential or other sensitive uses, and a consideration of nearby residents'/occupants' preferences. The project applicant shall notify property owners and occupants located within 300 feet at least 14 calendar days prior to construction activity proposed outside of the above days/hours. When submitting a request to the City to allow construction activity outside of the above days/hours, the project applicant shall submit information concerning the type and duration of proposed construction activity and the draft public notice for City review and approval prior to distribution of the public notice.

When Required: During construction

Initial Approval: N/A

Monitoring/Inspection: Bureau of Building

20. Construction Noise

Requirement: The project applicant shall implement noise reduction measures to reduce noise impacts due to construction. Noise reduction measures include, but are not limited to, the following:

- a. Equipment and trucks used for project construction shall utilize the best available noise control techniques (e.g., improved mufflers, equipment redesign, use of intake silencers, ducts, engine enclosures and acoustically-attenuating shields or shrouds) wherever feasible.
- b. Except as provided herein, impact tools (e.g., jack hammers, pavement breakers, and rock drills) used for project construction shall be hydraulically or electrically powered to avoid noise associated with compressed air exhaust from pneumatically powered tools. However, where use of pneumatic tools is unavoidable, an exhaust muffler on the compressed air exhaust shall be used; this muffler can lower noise levels from the exhaust by up to about 10 dBA. External jackets on the tools themselves shall be used, if such jackets are commercially available, and this could achieve a reduction of 5 dBA. Quieter procedures shall be used, such as drills rather than impact equipment, whenever such procedures are available and consistent with construction procedures.
- c. Applicant shall use temporary power poles instead of generators where feasible.
- d. Stationary noise sources shall be located as far from adjacent properties as possible, and they shall be muffled and enclosed within temporary sheds, incorporate insulation barriers, or use other measures as determined by the City to provide equivalent noise reduction.
- e. The noisiest phases of construction shall be limited to less than 10 days at a time. Exceptions may be allowed if the City determines an extension is necessary and all available noise reduction controls are implemented.

When Required: During construction

Initial Approval: N/A

Monitoring/Inspection: Bureau of Building

21. Extreme Construction Noise

a. Construction Noise Management Plan Required

Requirement: Prior to any extreme noise generating construction activities (e.g., pier drilling, pile driving and other activities generating greater than 90dBA), the project applicant shall submit a Construction Noise Management Plan prepared by a qualified acoustical consultant for City review and approval that contains a set of site-specific noise attenuation measures to further reduce construction impacts associated with extreme noise generating activities. The project applicant shall implement the approved Plan during construction. Potential attenuation measures include, but are not limited to, the following:

- i. Erect temporary plywood noise barriers around the construction site, particularly along on sites adjacent to residential buildings;
- ii. Implement “quiet” pile driving technology (such as pre-drilling of piles, the use of more than one pile driver to shorten the total pile driving duration), where feasible, in consideration of geotechnical and structural requirements and conditions;

- iii. Utilize noise control blankets on the building structure as the building is erected to reduce noise emission from the site;
- iv. Evaluate the feasibility of noise control at the receivers by temporarily improving the noise reduction capability of adjacent buildings by the use of sound blankets for example and implement such measure if such measures are feasible and would noticeably reduce noise impacts; and
- v. Monitor the effectiveness of noise attenuation measures by taking noise measurements.

When Required: Prior to approval of construction-related permit

Initial Approval: Bureau of Building

Monitoring/Inspection: Bureau of Building

b. *Public Notification Required*

Requirement: The project applicant shall notify property owners and occupants located within 300 feet of the construction activities at least 14 calendar days prior to commencing extreme noise generating activities. Prior to providing the notice, the project applicant shall submit to the City for review and approval the proposed type and duration of extreme noise generating activities and the proposed public notice. The public notice shall provide the estimated start and end dates of the extreme noise generating activities and describe noise attenuation measures to be implemented.

When Required: During construction

Initial Approval: Bureau of Building

Monitoring/Inspection: Bureau of Building

22. Operational Noise

Requirement: Noise levels from the project site after completion of the project (i.e., during project operation) shall comply with the performance standards of chapter 17.120 of the Oakland Planning Code and chapter 8.18 of the Oakland Municipal Code. If noise levels exceed these standards, the activity causing the noise shall be abated until appropriate noise reduction measures have been installed and compliance verified by the City.

When Required: Ongoing

Initial Approval: N/A

Monitoring/Inspection: Bureau of Building

23. Construction Activity in the Public Right-of-Way

a. *Obstruction Permit Required*

Requirement: The project applicant shall obtain an obstruction permit from the City prior to placing any temporary construction-related obstruction in the public right-of-way, including City streets and sidewalks.

When Required: Prior to approval of construction-related permit

Initial Approval: Bureau of Building

Monitoring/Inspection: Bureau of Building

b. *Traffic Control Plan Required*

Requirement: In the event of obstructions to vehicle or bicycle travel lanes, the project applicant shall submit a Traffic Control Plan to the City for review and approval prior to obtaining an obstruction permit. The project applicant shall submit evidence of City approval of the Traffic Control Plan with the application for an obstruction permit. The Traffic Control Plan shall contain a set of comprehensive traffic control measures for auto, transit, bicycle, and pedestrian detours, including detour signs if required, lane closure procedures, signs, cones for drivers, and designated construction access routes. The project applicant shall implement the approved Plan during construction.

When Required: Prior to approval of construction-related permit

Initial Approval: Public Works Department, Transportation Services Division

Monitoring/Inspection: Bureau of Building

b. *Repair of City Streets*

Requirement: The project applicant shall repair any damage to the public right-of way, including streets and sidewalks caused by project construction at his/her expense within one week of the occurrence of the damage (or excessive wear), unless further damage/excessive wear may continue; in such case, repair shall occur prior to approval of the final inspection of the construction-related permit. All damage that is a threat to public health or safety shall be repaired immediately.

When Required: Prior to building permit final

Initial Approval: N/A

Monitoring/Inspection: Bureau of Building

24. Construction and Demolition Waste Reduction and Recycling

Requirement: The project applicant shall comply with the City of Oakland Construction and Demolition Waste Reduction and Recycling Ordinance (chapter 15.34 of the Oakland Municipal Code) by submitting a Construction and Demolition Waste Reduction and Recycling Plan (WRRP) for City review and approval, and shall implement the approved WRRP. Projects subject to these requirements include all new construction, renovations/alterations/modifications with construction values of \$50,000 or more (except R-3 type construction), and all demolition (including soft demolition) except demolition of type R-3 construction. The WRRP must specify the methods by which the project will divert construction and demolition debris waste from landfill disposal in accordance with current City requirements. The WRRP may be submitted electronically at www.greenhalosystems.com or manually at the City's Green Building Resource Center. Current standards, FAQs, and forms are available on the City's website and in the Green Building Resource Center.

When Required: Prior to approval of construction-related permit

Initial Approval: Public Works Department, Environmental Services Division

Monitoring/Inspection: Public Works Department, Environmental Services Division

25. Underground Utilities

Requirement: The project applicant shall place underground all new utilities serving the project and under the control of the project applicant and the City, including all new gas, electric, cable, and telephone facilities, fire alarm conduits, street light wiring, and other wiring, conduits, and similar facilities. The new facilities shall be placed underground along the project's street frontage and from the project structures to the point of service. Utilities under the control of other agencies, such as PG&E, shall be placed underground if feasible. All utilities shall be installed in accordance with standard specifications of the serving utilities.

When Required: During construction

Initial Approval: N/A

Monitoring/Inspection: Bureau of Building

PROJECT-SPECIFIC CONDITIONS

26. Public Works Review

Requirement: The plans shall receive a satisfactory review from the Public Works Agency, incorporating any required modifications.

When Required: Prior to submitting a building permit application

Initial Approval: N/A

Monitoring/Inspection: N/A

27. Emissions Report

Requirement: A RF emissions report shall be submitted to the Planning Bureau indicating that the site is actually operating within the acceptable thresholds as established by the Federal government or any such agency who may be subsequently authorized to establish such standards.

Requirement: Prior to a final inspection

When Required: Prior to submitting a building permit application

Initial Approval: N/A

Monitoring/Inspection: N/A

28. Camouflage

Requirement: The antenna shall be painted, texturized, and maintained matte silver, and the equipment and any other accessory items including cables matte brown, to better camouflage the facility to the utility pole and attached power line posts.

When Required: Prior to a final inspection

Initial Approval: N/A

Monitoring/Inspection: Bureau of Building

29. Operational

Requirement: Noise levels from the activity, property, or any mechanical equipment on site shall comply with the performance standards of Section 17.120 of the Oakland Planning Code and Section 8.18 of the Oakland Municipal Code. If noise levels exceed these

standards, the activity causing the noise shall be abated until appropriate noise reduction measures have been installed and compliance verified by the Planning and Zoning Division and Building Services.

When Required: Ongoing

Initial Approval: N/A

Monitoring/Inspection: Bureau of Building

30. Possible District Undergrounding PG&E Pole

Requirement: Should the PG &E utility pole be permanently removed for purposes of district undergrounding or otherwise, the telecommunications facility can only be re-established by applying for and receiving approval of a new application to the Oakland Planning Bureau as required by the regulations.

When Required: Ongoing

Initial Approval: N/A

Monitoring/Inspection: N/A

Attachment C

NW-CA-SANFRNMC 06103A

ADJACENT TO (IN PROW)
1301 90TH AVENUE
OAKLAND, CA 94603

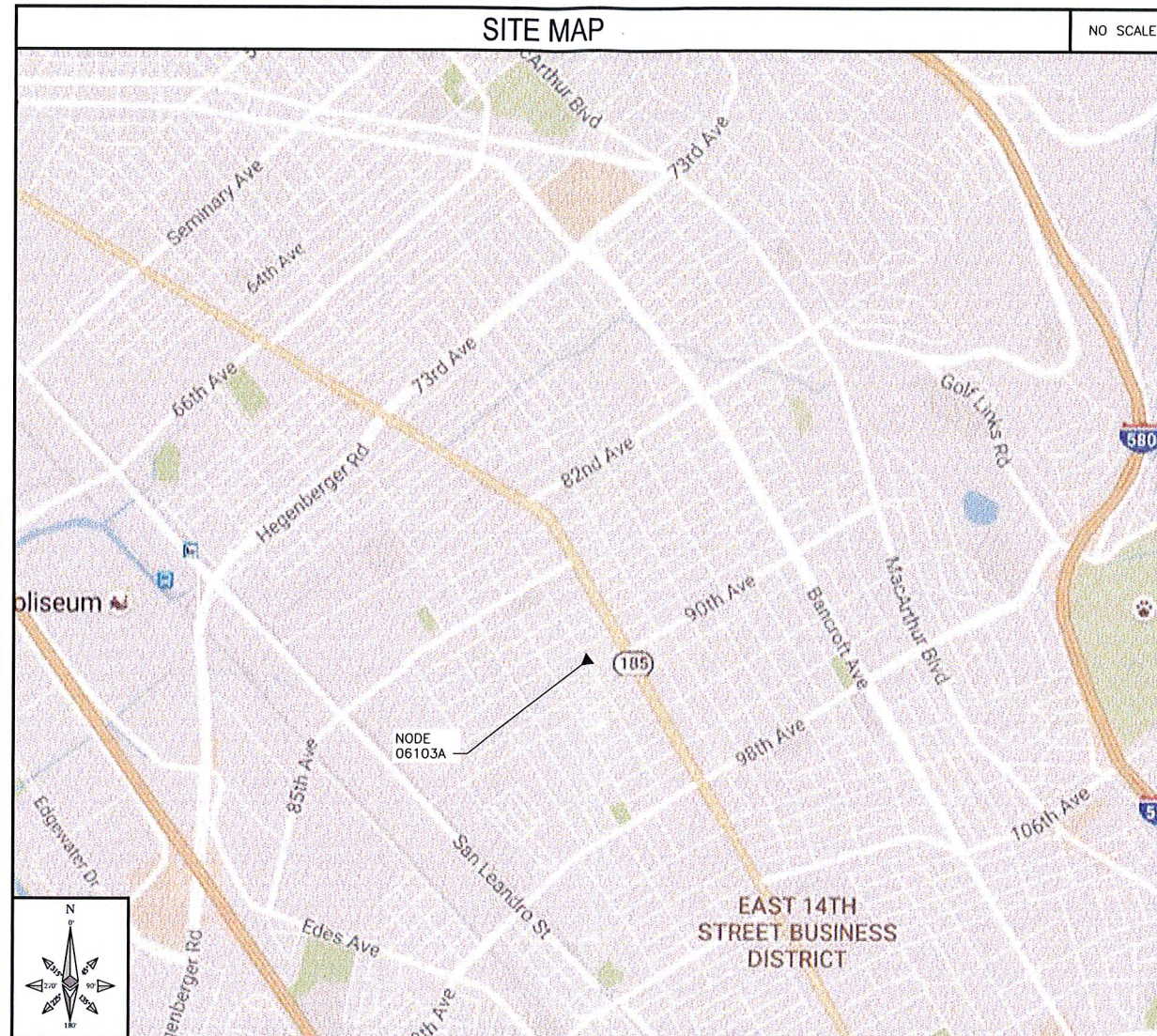
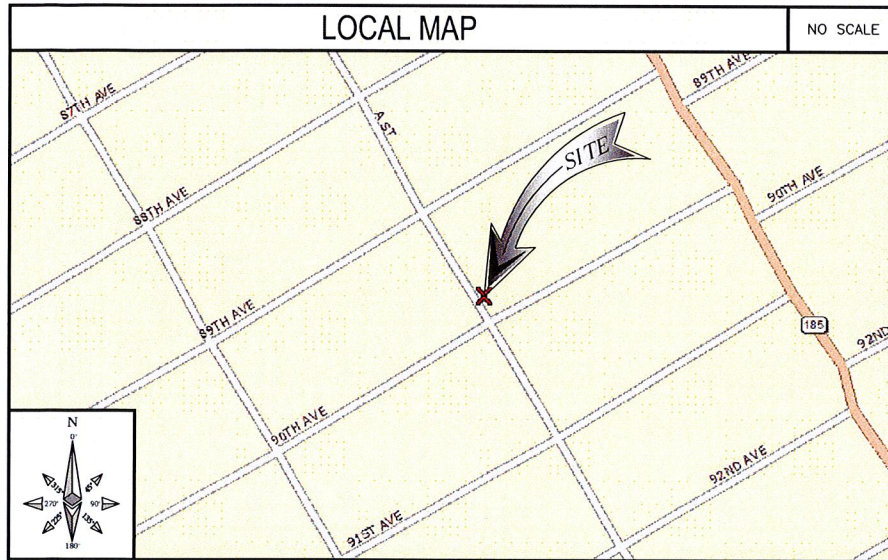

CODE COMPLIANCE

ALL WORK AND MATERIALS SHALL BE PERFORMED AND INSTALLED IN ACCORDANCE WITH THE CURRENT EDITIONS OF THE FOLLOWING CODES AS ADOPTED BY THE LOCAL GOVERNING AUTHORITIES (AS APPLICABLE). NOTHING IN THESE PLANS IS TO BE CONSTRUCTED TO PERMIT WORK NOT CONFORMING TO THESE CODES.

- 1: IBC - 2012
- 2: CALIFORNIA BUILDING STANDARDS CODE - 2013
- 3: CALIFORNIA GENERAL ORDER 95
- 4: CALIFORNIA MECHANICAL CODE 2013
- 5: CALIFORNIA PLUMBING CODE 2013
- 6: CALIFORNIA ELECTRICAL CODE 2013
- 7: CITY AND/OR COUNTY ORDINANCES
- 8: 2012 INTERNATIONAL FIRE CODE
- 9: BUILDING OFFICIALS AND CODE ADMINISTRATORS (BOCA) *EFFECTIVE UNTIL JANUARY 1ST, 2017

PROJECT DESCRIPTION

THESE DRAWINGS DEPICT THE INSTALLATION OF A WIRELESS TELECOMMUNICATIONS NODE IN THE PUBLIC RIGHT OF WAY. HARDWARE AND ANCILLARY EQUIPMENT TO BE INSTALLED AS DESCRIBED HEREIN.

GENERAL PROJECT NOTES

1. PRIOR TO SUBMITTING A BID, THE CONTRACTOR SHALL FAMILIARIZE HIMSELF/HERSELF WITH THE SCOPE OF WORK AND ALL CONDITIONS AFFECTING THE NEW PROJECT.
2. CONTRACTOR SHALL VERIFY ALL FIELD CONDITIONS AND DIMENSIONS OF THE JOB SITE AND CONFIRM THAT WORK AS INDICATED ON THESE CONSTRUCTION DOCUMENTS CAN BE ACCOMPLISHED AS SHOWN PRIOR TO COMMENCEMENT OF ANY WORK.
3. ALL FIELD MODIFICATIONS BEFORE, DURING OR AFTER CONSTRUCTION SHALL BE APPROVED IN WRITING BY AN EXTENET SYSTEMS REPRESENTATIVE.
4. INSTALL ALL EQUIPMENT AND MATERIALS PER THE MANUFACTURER'S RECOMMENDATIONS, UNLESS INDICATED OTHERWISE.
5. NOTIFY EXTENET SYSTEMS, IN WRITING, OF ANY MAJOR DISCREPANCIES REGARDING THE CONTRACT DOCUMENTS, EXISTING CONDITIONS, AND DESIGN INTENT. THE CONTRACTOR SHALL BE RESPONSIBLE FOR OBTAINING CLARIFICATIONS FROM AN EXTENET SYSTEMS REPRESENTATIVE, AND ADJUSTING THE BID ACCORDINGLY.
6. CONTRACTOR SHALL BE SOLELY RESPONSIBLE FOR ALL CONSTRUCTION MEANS, METHODS, TECHNIQUES, SEQUENCES AND PROCEDURES OF THE WORK UNDER THE CONTRACT.
7. CONTRACTOR SHALL PROTECT ALL EXISTING IMPROVEMENTS AND FINISHES THAT ARE TO REMAIN. CONTRACTOR SHALL REPAIR ANY DAMAGE THAT MAY OCCUR DURING THE CONSTRUCTION TO THE SATISFACTION OF AN EXTENET SYSTEMS REPRESENTATIVE.
8. CONTRACTOR PLANS TO ILLUSTRATE THE AS-BUILT CONDITION OF THE SITE. FOLLOWING THE FINAL INSPECTION BY EXTENET OR TMOBILE, THE CONTRACTOR SHALL PROVIDE EXTENET SYSTEMS WITH ONE COPY OF ALL RED-LINED DRAWINGS.
9. VERIFY ALL FINAL EQUIPMENT WITH AN EXTENET SYSTEMS REPRESENTATIVE. ALL EQUIPMENT LAYOUT, SPECS, PERFORMANCE INSTALLATION AND THEIR FINAL LOCATION ARE TO BE APPROVED BY EXTENET SYSTEMS. THE CONTRACTOR SHALL BE RESPONSIBLE FOR COORDINATING HIS/HER WORK WITH THE WORK AND CLEARANCES REQUIRED BY OTHERS RELATED TO SAID INSTALLATIONS.



INTERNAL REVIEW	
CONSTRUCTION SIGNATURE	DATE
RF SIGNATURE	DATE
REAL ESTATE SIGNATURE	DATE

BLACK & VEATCH CORPORATION
7760 FRANCE AVE
SUITE 1200
BLOOMINGTON, MN 55435

THESE DRAWINGS ARE COPYRIGHTED AND ARE THE PROPERTY OF BLACK & VEATCH; PRODUCED SOLELY FOR THE USE OF OUR CLIENT. ANY REPRODUCTION OR USE OF THE INFORMATION CONTAINED WITHIN SAID DRAWINGS IS PROHIBITED WITHOUT WRITTEN CONSENT BY BLACK & VEATCH.

PROJECT NO.	DRAWN BY	CHECKED BY
192417.4381	DLG	GAC

REV	DATE	DESCRIPTION
B	09/27/16	ISSUED FOR REVIEW
A	09/27/16	ISSUED FOR REVIEW

PRELIMINARY

IT IS A VIOLATION OF LAW FOR ANY PERSON, UNLESS THEY ARE ACTING UNDER THE DIRECTION OF A LICENSED PROFESSIONAL ENGINEER, TO ALTER THIS DOCUMENT.

EXTENET SYSTEMS (CA) LLC
2000 CROW CANYON PLACE
SUITE 210
SAN RAMON, CA 94583

SITE ADDRESS
ADJACENT TO (IN PROW)
1301 90TH AVENUE
OAKLAND, CA 94603

SHEET TITLE
TITLE SHEET

SHEET NUMBER
T-1

SHEET INDEX

SHEET NO:	SHEET TITLE
T-1	TITLE SHEET
GN-1	GENERAL NOTES AND LEGEND
C-1	OVERALL SITE PLAN
C-2	UTILITY POLE ELEVATIONS AND RISER DETAILS
C-3	EQUIPMENT DETAILS
C-4	EQUIPMENT DETAILS

PROJECT INFORMATION

POLE OWNER	APPLICANT
OWNER: EXTENET SYSTEMS CA, LLC	COMPANY: EXTENET SYSTEMS (CALIFORNIA), LLC.
ADDRESS: 2000 CROW CANYON PL., SUITE 210, SAN RAMON, CA 94583	CONTACT: MATTHEW YERGOVICH
PHONE: -	ADDRESS: 2000 CROW CANYON PL., SUITE 210, SAN RAMON, CA 94583
	PHONE: (415) 596-3474
	E-MAIL: MYERGOVICH@EXTENETSYSTEMS.COM

AGENT

COMPANY: BLACK & VEATCH
CONTACT: ANA GOMEZ
ADDRESS: 2999 OAK ROAD, SUITE 490, WALNUT CREEK, CA 94597
PHONE: (913) 458-9148
E-MAIL: GOMEZABARCAA@BV.COM

ENGINEER

COMPANY: BLACK & VEATCH
ENGINEER: AARON EVANS
PHONE: (952) 896-0751
E-MAIL: EVANSRA@BV.COM

PROJECT DATA

LATITUDE: 37.7491730'
LONGITUDE: -122.1764010'
POLE #: 110124641
ELEVATION: NA
ZONING JURISDICTION: CITY OF OAKLAND
ZONING DISTRICT: RD-1
NEAREST A.P.N.: 42-4270-15
OCCUPANCY: U, UNMANNED
CONSTRUCTION TYPE: ATTACHMENTS TO A WOOD UTILITY POLE
TITLE 24 REQUIREMENTS: FACILITY IS UNMANNED AND NOT FOR HUMAN HABITATION. THIS PROJECT IS EXEMPT.

IF USING 11"X17" PLOT, DRAWINGS WILL BE HALF SCALE

SUBCONTRACTOR SHALL VERIFY ALL PLANS & EXISTING DIMENSIONS & CONDITIONS ON THE JOB SITE & SHALL IMMEDIATELY NOTIFY THE ENGINEER IN WRITING OF ANY DISCREPANCIES BEFORE PROCEEDING WITH THE WORK OR BE RESPONSIBLE FOR SAME

UNDERGROUND SERVICE ALERT
UTILITIES PROTECTION CENTER, INC.
811
48 HOURS BEFORE YOU DIG

GENERAL NOTES

- THESE NOTES SHALL BE CONSIDERED A PART OF THE WRITTEN SPECIFICATIONS, CONTRACT AND CONSTRUCTION DOCUMENTS.
- THE WORK SHALL INCLUDE FURNISHING MATERIALS, EQUIPMENT, APPURTENANCES, AND LABOR NECESSARY TO COMPLETE ALL INSTALLATIONS AS INDICATED ON THESE PLANS AND IN THE CONTRACT DOCUMENTS.
- PRIOR TO THE SUBMISSION OF BIDS, THE CONTRACTOR(S) SHALL VISIT THE JOB SITE(S) AND BE RESPONSIBLE FOR ALL CONTRACT DOCUMENTS, FIELD CONDITIONS AND DIMENSIONS, AND CONFIRM THAT THE WORK MAY BE ACCOMPLISHED PER THE CONTRACT DOCUMENTS. ANY DISCREPANCIES ARE TO BE BROUGHT TO THE ATTENTION OF THE IMPLEMENTATION ENGINEER AND ARCHITECT/ENGINEER PRIOR TO BID SUBMITTAL.
- THE CONTRACTOR SHALL RECEIVE WRITTEN AUTHORIZATION TO PROCEED ON ANY WORK NOT CLEARLY DEFINED OR IDENTIFIED IN THE CONTRACT AND CONSTRUCTION DOCUMENTS BEFORE STARTING ANY WORK.
- ALL WORK PERFORMED AND MATERIALS INSTALLED SHALL BE IN STRICT ACCORDANCE WITH ALL APPLICABLE CODES, REGULATIONS, AND ORDINANCES, INCLUDING APPLICABLE MUNICIPAL AND UTILITY COMPANY SPECIFICATIONS.
- THE CONTRACTOR SHALL INSTALL ALL EQUIPMENT AND MATERIALS IN ACCORDANCE WITH MANUFACTURER RECOMMENDATIONS. IF THESE RECOMMENDATIONS ARE IN CONFLICT WITH THE CONTRACT AND CONSTRUCTION DOCUMENTS AND/OR APPLICABLE CODES OR REGULATIONS, REVIEW AND RESOLVE THE CONFLICT WITH DIRECTION FROM THE IMPLEMENTATION ENGINEER AND ARCHITECT/ENGINEER PRIOR TO PROCEEDING.
- THE CONTRACTOR SHALL BE SOLELY RESPONSIBLE FOR ALL CONSTRUCTION MEANS, METHODS, TECHNIQUES, SEQUENCES, AND PROCEDURES AND FOR COORDINATION OF ALL PORTIONS OF THE WORK UNDER THE CONTRACT INCLUDING CONTACT AND COORDINATION WITH THE IMPLEMENTATION ENGINEER AND WITH THE AUTHORIZED REPRESENTATIVE OF ANY OUTSIDE POLE OR PROPERTY OWNER.
- THE CONTRACTOR SHALL MAKE NECESSARY PROVISIONS TO PROTECT EXISTING IMPROVEMENTS, INCLUDING BUT NOT LIMITED TO PAVING, CURBS, VEGETATION, GALVANIZED SURFACE OR OTHER EXISTING ELEMENTS AND UPON COMPLETION OF THE WORK, REPAIR ANY DAMAGE THAT OCCURRED DURING CONSTRUCTION TO THE SATISFACTION OF EXTENET.
- CONTRACTOR IS TO KEEP THE GENERAL AREA CLEAN, HAZARD FREE, AND DISPOSE OF ALL DIRT, DEBRIS, RUBBISH, AND REMOVE EQUIPMENT NOT SPECIFIED AS REMAINING ON THE PROPERTY. LEAVE PREMISES IN CLEAN CONDITION DAILY.
- PLANS ARE INTENDED TO BE DIAGRAMMATIC ONLY AND SHOULD NOT BE SCALED UNLESS OTHERWISE NOTED. RELY ONLY ON ANNOTATED DIMENSIONS AND REQUEST INFORMATION IF ADDITIONAL DIMENSIONS ARE REQUIRED.
- THE EXISTENCE AND LOCATION OF UTILITIES AND OTHER AGENCY'S FACILITIES WERE OBTAINED BY A SEARCH OF AVAILABLE RECORDS. OTHER FACILITIES MAY EXIST. CONTRACTOR SHALL VERIFY LOCATIONS PRIOR TO START OF CONSTRUCTION AND USE EXTREME CARE AND PROTECTIVE MEASURES TO PREVENT DAMAGE TO THESE FACILITIES. CONTRACTOR IS RESPONSIBLE FOR THE PROTECTION OF UTILITIES OR OTHER AGENCY'S FACILITIES WITHIN THE LIMITS OF THE WORK. WHETHER THEY ARE IDENTIFIED IN THE CONTRACT DOCUMENTS OR NOT.
- THE CONTRACTOR SHALL NOTIFY UNDERGROUND SERVICE ALERT (800) 227-2600, AT LEAST TWO WORKING DAYS PRIOR TO THE START OF ANY EXCAVATION.

DEFINITIONS

- "TYPICAL" OR "TYP" MEANS THAT THIS ITEM IS SUBSTANTIALLY THE SAME ACROSS SIMILAR CONDITIONS. "TYP." SHALL BE UNDERSTOOD TO MEAN "TYPICAL WHERE OCCURS" AND SHALL NOT BE CONSIDERED AS WITHOUT EXCEPTION OR CONSIDERATION OF SPECIFIC CONDITIONS.
- "SIMILAR" MEANS COMPARABLE TO CHARACTERISTICS FOR THE CONDITION NOTED. VERIFY DIMENSIONS AND ORIENTATION ON PLAN.
- "AS REQUIRED" MEANS AS REQUIRED BY REGULATORY REQUIREMENTS, BY REFERENCED STANDARDS, BY EXISTING CONDITIONS, BY GENERALLY ACCEPTED CONSTRUCTION PRACTICE, OR BY THE CONTRACT DOCUMENTS.
- "ALIGN" MEANS ACCURATELY LOCATE FINISH FACES OF MATERIALS IN THE SAME PLANE.
- THE TERM "VERIFY" OR "V.I.F." SHALL BE UNDERSTOOD TO MEAN "VERIFY IN FIELD WITH ENGINEER" AND REQUIRES THAT THE CONTRACTOR CONFIRM INTENTION REGARDING NOTED CONDITION AND PROCEED ONLY AFTER RECEIVING DIRECTION.
- WHERE THE WORDS "OR EQUAL" OR WORDS OF SIMILAR INTENT FOLLOW A MATERIAL SPECIFICATION, THEY SHALL BE UNDERSTOOD TO REQUIRE SIGNED APPROVAL OF ANY DEVIATION TO SAID SPECIFICATION PRIOR TO CONTRACTOR'S ORDERING OR INSTALLATION OF SUCH PROPOSED EQUAL PRODUCT.
- FURNISH : SUPPLY ONLY, OTHERS TO INSTALL. INSTALL: INSTALL ITEMS FURNISHED BY OTHERS. PROVIDE: FURNISH AND INSTALL.

FIELD WELDING NOTES:

- WELDING TO BE PERFORMED BY AWS CERTIFIED WELDER FOR THE TYPE OF AND POSITION INDICATED. ALL WORK MUST BE IN CONFORMANCE WITH LATEST EDITION OF AWS D1.1.
- GRIND SURFACES TO BE WELDED WITH A SILICON CARBIDE WHEEL PRIOR TO WELDING TO REMOVE ALL GALVANIZING WHICH MAY OTHERWISE BE CONSUMED IN THE WELD METAL. APPLY ANTI-SPATTER COMPOUND AFTER GRINDING.
- WELDING TECHNIQUE MUST MINIMIZE TEMPERATURE RISE ON THE INSIDE SURFACE OF THE POLE AND ALSO VOLATIZE ANY REMAINING ZINC WITHIN THE BASE METAL WITH MINIMUM SPATTER. USE AN E70 (LOW HYDROGEN) ELECTRODE. USE LARGEST DIAMETER ELECTRODE COMPATIBLE WITH WELDING POSITION AND MATERIAL THICKNESS. STRICTLY FOLLOW ALL MANUFACTURE'S INSTRUCTIONS FOR STORAGE AND USE OF ELECTRODES. AVOID REMOVING ELECTRODES FROM MANUFACTURE'S PACKAGING UNTIL READY FOR IMMEDIATE USE.
- WELDING MAY PRODUCE TOXIC FUMES. REFER TO ANSI STANDARD Z49.1 "SAFETY IN WELDING AND CUTTING" FOR PROPER PRECAUTIONS.
- UPON COMPLETION OF WELDING, APPLY GALV-A-STICK ZINC COATING TO ALL UNPROTECTED SURFACES. APPLY A SECOND LAYER OF COLD GALVANIZING SPRAY COMPOUND CONTAINING A MINIMUM ZINC CONTENT OF 95%. IF NECESSARY, APPLY A FINAL COAT OF COMPATIBLE PAINT TO MATCH SURROUNDING SURFACES.

ANTENNA MOUNTING

- DESIGN AND CONSTRUCTION OF ANTENNA SUPPORTS SHALL CONFORM TO CURRENT ANSI/TIA-222 OR APPLICABLE LOCAL CODES.
- ALL STEEL MATERIALS SHALL BE GALVANIZED AFTER FABRICATION IN ACCORDANCE WITH ASTM A123 "ZINC (HOT-DIP GALVANIZED) COATINGS ON IRON AND STEEL PRODUCTS", UNLESS NOTED OTHERWISE.
- ALL BOLTS, ANCHORS AND MISCELLANEOUS HARDWARE SHALL BE GALVANIZED IN ACCORDANCE WITH ASTM A153 "ZINC-COATING (HOT-DIP) ON IRON AND STEEL HARDWARE", UNLESS NOTED OTHERWISE.
- DAMAGED GALVANIZED SURFACES SHALL BE REPAIRED BY COLD GALVANIZING IN ACCORDANCE WITH ASTM A780.
- ALL ANTENNA MOUNTS SHALL BE INSTALLED WITH LOCK NUTS, DOUBLE NUTS AND SHALL BE TORQUED TO MANUFACTURER'S RECOMMENDATIONS.
- CONTRACTOR SHALL INSTALL ANTENNA PER MANUFACTURER'S RECOMMENDATION FOR INSTALLATION AND GROUNDING.
- PRIOR TO SETTING ANTENNA AZIMUTHS AND DOWNTILTS, ANTENNA CONTRACTOR SHALL CHECK THE ANTENNA MOUNT FOR TIGHTNESS AND ENSURE THAT THEY ARE PLUMB. ANTENNA AZIMUTHS SHALL BE SET FROM TRUE NORTH AND BE ORIENTED WITHIN +/- 5% AS DEFINED BY THE RFDS. ANTENNA DOWNTILTS SHALL BE WITHIN +/- 0.5% AS DEFINED BY THE RFDS.

TORQUE REQUIREMENTS

- ALL RF CONNECTIONS SHALL BE TIGHTENED BY A TORQUE WRENCH.
- ALL RF CONNECTIONS, GROUNDING HARDWARE AND ANTENNA HARDWARE SHALL HAVE A TORQUE MARK INSTALLED IN A CONTINUOUS STRAIGHT LINE FROM BOTH SIDES OF THE CONNECTION.
 - RF CONNECTION BOTH SIDES OF THE CONNECTOR.
 - GROUNDING AND ANTENNA HARDWARE ON THE NUT SIDE STARTING FROM THE THREADS TO THE SOLID SURFACE. EXAMPLE OF SOLID SURFACE: GROUND BAR, ANTENNA BRACKET METAL.
- ALL 8M ANTENNA HARDWARE SHALL BE TIGHTENED TO 9 LB-FT (12 NM).
- ALL 12M ANTENNA HARDWARE SHALL BE TIGHTENED TO 43 LB-FT (58 NM).
- ALL GROUNDING HARDWARE SHALL BE TIGHTENED UNTIL THE LOCK WASHER COLLAPSES AND THE GROUNDING HARDWARE IS NO LONGER LOOSE.
- ALL DIN TYPE CONNECTIONS SHALL BE TIGHTENED TO 18-22 LB-FT (24.4 - 29.8 NM).
- ALL N TYPE CONNECTIONS SHALL BE TIGHTENED TO 15-20 LB-IN (1.7 - 2.3 NM).

ROW UTILITY POLE CONSTRUCTION NOTES

- NO BOLT THREADS TO PROTRUDE MORE THAN 1-1/2" [.038M].
- FILL ALL HOLES LEFT IN POLE FROM REARRANGEMENT OF CLIMBERS.
- ALL CLIMB STEPS NEXT TO CONDUIT SHALL HAVE EXTENDED STEPS.
- CABLE NOT TO IMPEDE 15" [.381M] CLEAR SPACE OFF POLE FACE (12:00).
- 90 SHORT SWEEPS UNDER ANTENNA ARM. ALL CABLES MUST ONLY TRANSITION ON THE INSIDE OR BOTTOM OF ARMS (NO CABLE ON TOP OF ARMS).
- USE 90 CONNECTOR AT CABLE CONNECTION TO ANTENNAS.
- USE 1/2" [.013M] CABLE ON ANTENNAS UNLESS OTHERWISE SPECIFIED.
- FILL VOID AROUND CABLES AT CONDUIT OPENING WITH FOAM SEALANT TO PREVENT WATER INTRUSION.

NODE SITE POWER SHUT DOWN PROCEDURES

- FOR NON EMERGENCY/SCHEDULED POWER SHUT DOWN
 - CALL EXTENET SYSTEMS NOC (NETWORK OPERATIONS CENTER) (866)892-5327
 - 24 HOURS PRIOR TO SCHEDULED POWER SHUT OFF
 - PROVIDE THE FOLLOWING INFORMATION
 - NOC SITE NUMBER IDENTIFIED ON SITE NUMBERING STICKER
 - YOUR NAME AND REASON FOR POWER SHUTOFF
 - PROVIDE DURATION OF OUTAGE
 - UNLOCK DISCONNECT BOX, FLIP BOTH BREAKERS TO THE OFF POSITION
 - POWER SHUT OFF VERIFICATION WITH APPROVED PG&E PROCEDURES
 - NOTIFY EXTENET NOC UPON COMPLETION OF WORK
 - REINSTALL LOCK ON DISCONNECT BOX
- EMERGENCY POWER SHUT OFF
 - CALL EXTENET SYSTEMS NOC (NETWORK OPERATIONS CENTER) (866)892-5327
 - PROVIDE THE FOLLOWING INFORMATION
 - NOC SITE NUMBER IDENTIFIED ON SITE NUMBERING STICKER
 - YOUR NAME AND REASON FOR POWER SHUTOFF
 - PROVIDE DURATION OF OUTAGE
 - UNLOCK DISCONNECT BOX, FLIP BOTH BREAKERS TO THE OFF POSITION
 - POWER SHUT OFF VERIFICATION WITH APPROVED PG&E PROCEDURES
 - NOTIFY EXTENET NOC UPON COMPLETION OF WORK
 - REINSTALL LOCK ON DISCONNECT BOX

LEGEND

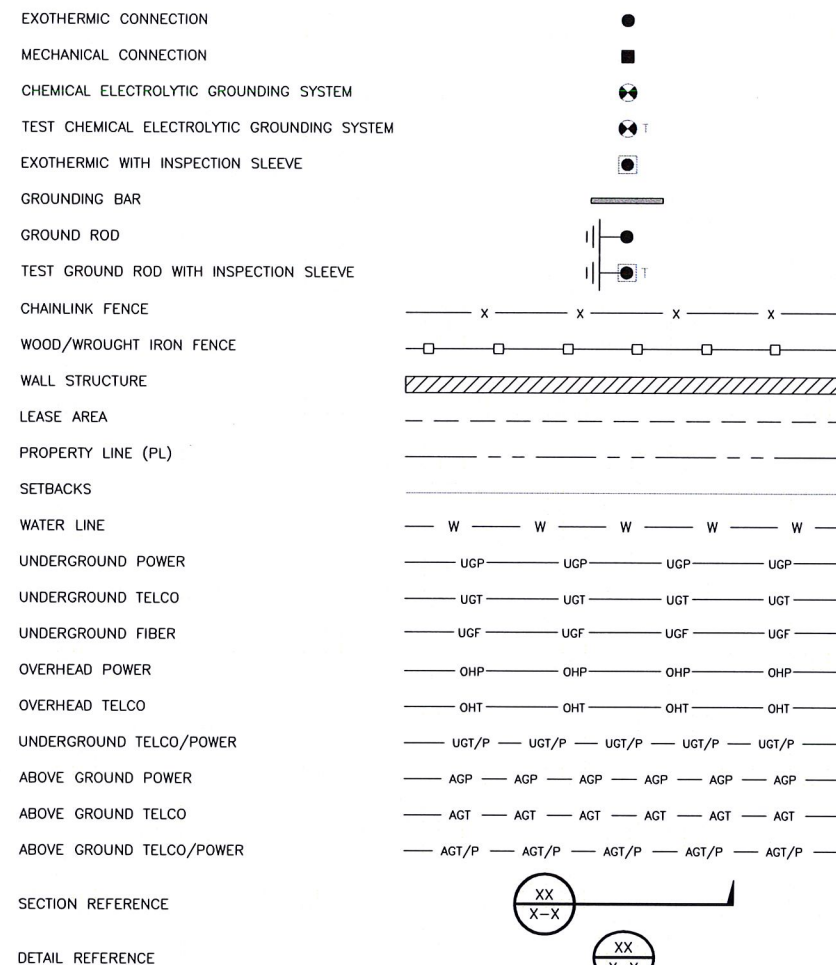

INTERNAL REVIEW	
CONSTRUCTION SIGNATURE	DATE
RF SIGNATURE	DATE
REAL ESTATE SIGNATURE	DATE

BLACK & VEATCH CORPORATION
7760 FRANCE AVE
SUITE 1200
BLOOMINGTON, MN 55435

THESE DRAWINGS ARE COPYRIGHTED AND ARE THE PROPERTY OF BLACK & VEATCH. PRODUCED SOLELY FOR THE USE OF OUR CLIENT. ANY REPRODUCTION OR USE OF THE INFORMATION CONTAINED WITHIN SAID DRAWINGS IS PROHIBITED WITHOUT WRITTEN CONSENT BY BLACK & VEATCH.

PROJECT NO.	DRAWN BY	CHECKED BY
192417.4381	DLG	GAC

REV	DATE	DESCRIPTION
B	09/27/16	ISSUED FOR REVIEW
A	09/27/16	ISSUED FOR REVIEW

PRELIMINARY

IT IS A VIOLATION OF LAW FOR ANY PERSON, UNLESS THEY ARE ACTING UNDER THE DIRECTION OF A LICENSED PROFESSIONAL ENGINEER, TO ALTER THIS DOCUMENT.

EXTENET SYSTEMS (CA) LLC
2000 CROW CANYON PLACE
SUITE 210
SAN RAMON, CA 94583

SITE ADDRESS
ADJACENT TO (IN PROW)
1301 90TH AVENUE
OAKLAND, CA 94603

SHEET TITLE
GENERAL NOTES
AND LEGEND

SHEET NUMBER
GN-1

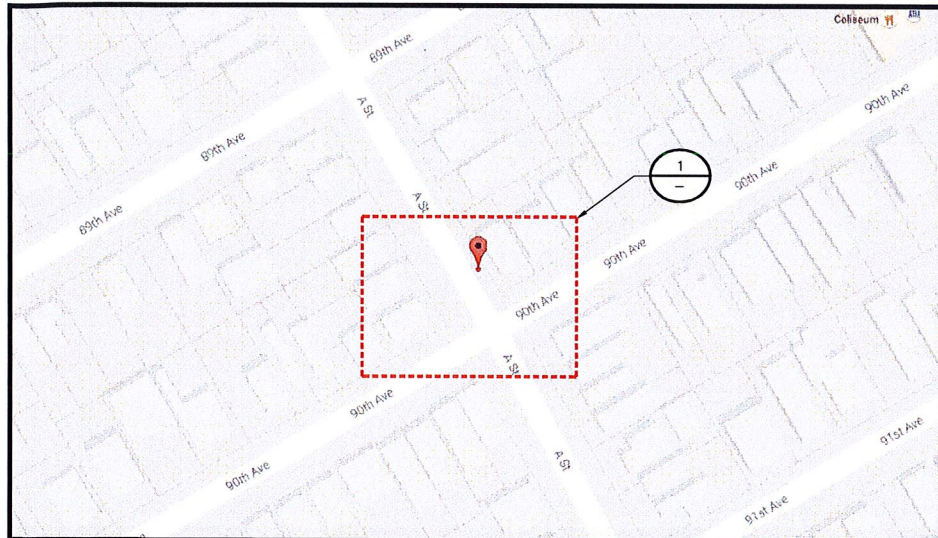

SITE PLAN PHOTO

NO SCALE

A

THIS DRAWING IS NOT A SITE SURVEY
 THE PURPOSE OF THIS DRAWING IS TO SHOW HOW THE DEVELOPED SITE RELATES TO THE PARENT PARCEL AND ADJACENT PROPERTIES. R.O.W. MEASUREMENTS ARE APPROXIMATIONS.

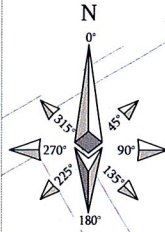
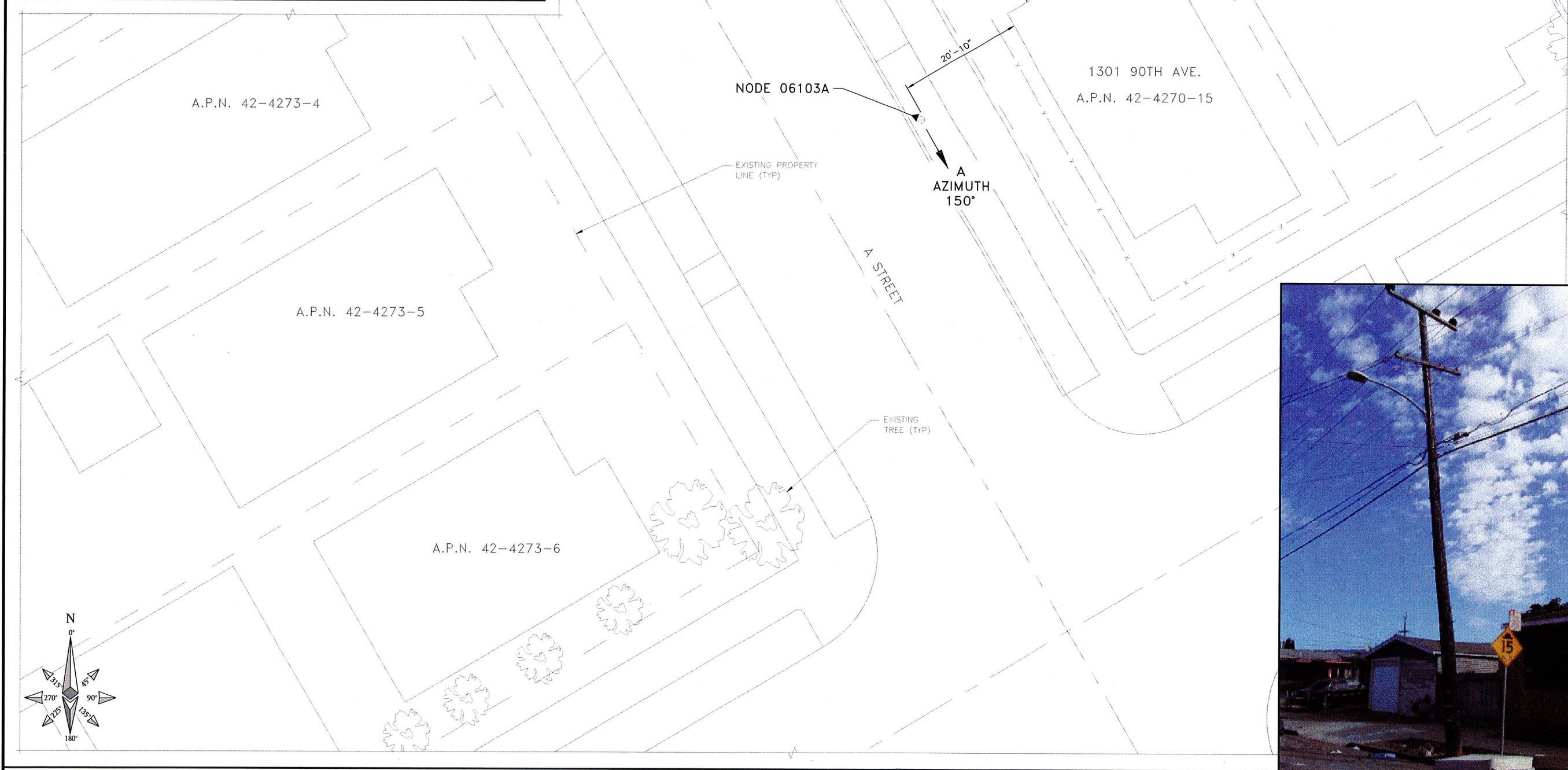

OVERALL SITE PLAN

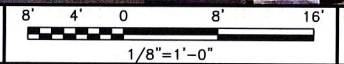

INTERNAL REVIEW	
CONSTRUCTION SIGNATURE	DATE
RF SIGNATURE	DATE
REAL ESTATE SIGNATURE	DATE



BLACK & VEATCH
 BLACK & VEATCH CORPORATION
 7760 FRANCE AVE
 SUITE 1200
 BLOOMINGTON, MN 55435

THESE DRAWINGS ARE COPYRIGHTED AND ARE THE PROPERTY OF BLACK & VEATCH; PRODUCED SOLELY FOR THE USE OF OUR CLIENT. ANY REPRODUCTION OR USE OF THE INFORMATION CONTAINED WITHIN SAID DRAWINGS IS PROHIBITED WITHOUT WRITTEN CONSENT BY BLACK & VEATCH.

PROJECT NO.	DRAWN BY	CHECKED BY
192417.4381	DLG	GAC

REV	DATE	DESCRIPTION
B	09/27/16	ISSUED FOR REVIEW
A	09/27/16	ISSUED FOR REVIEW

PRELIMINARY

IT IS A VIOLATION OF LAW FOR ANY PERSON, UNLESS THEY ARE ACTING UNDER THE DIRECTION OF A LICENSED PROFESSIONAL ENGINEER, TO ALTER THIS DOCUMENT.

EXTENET SYSTEMS (CA) LLC
 2000 CROW CANYON PLACE
 SUITE 210
 SAN RAMON, CA 94583

SITE ADDRESS
 ADJACENT TO (IN PROW)
 1301 90TH AVENUE
 OAKLAND, CA 94603

SHEET TITLE
 OVERALL SITE PLAN

SHEET NUMBER
C-1

NOTE

THESE DRAWINGS HAVE BEEN CREATED BASED ON THE ASSUMPTION THAT THE STRUCTURE HAS SUFFICIENT CAPACITY TO SUPPORT THE PROPOSED LOADING. IT IS THE RESPONSIBILITY OF THE POLE OWNER TO CONFIRM THAT THE PROPOSED LOADING IS WITHIN THE ORIGINAL DESIGN CAPACITY OF THE STRUCTURE.

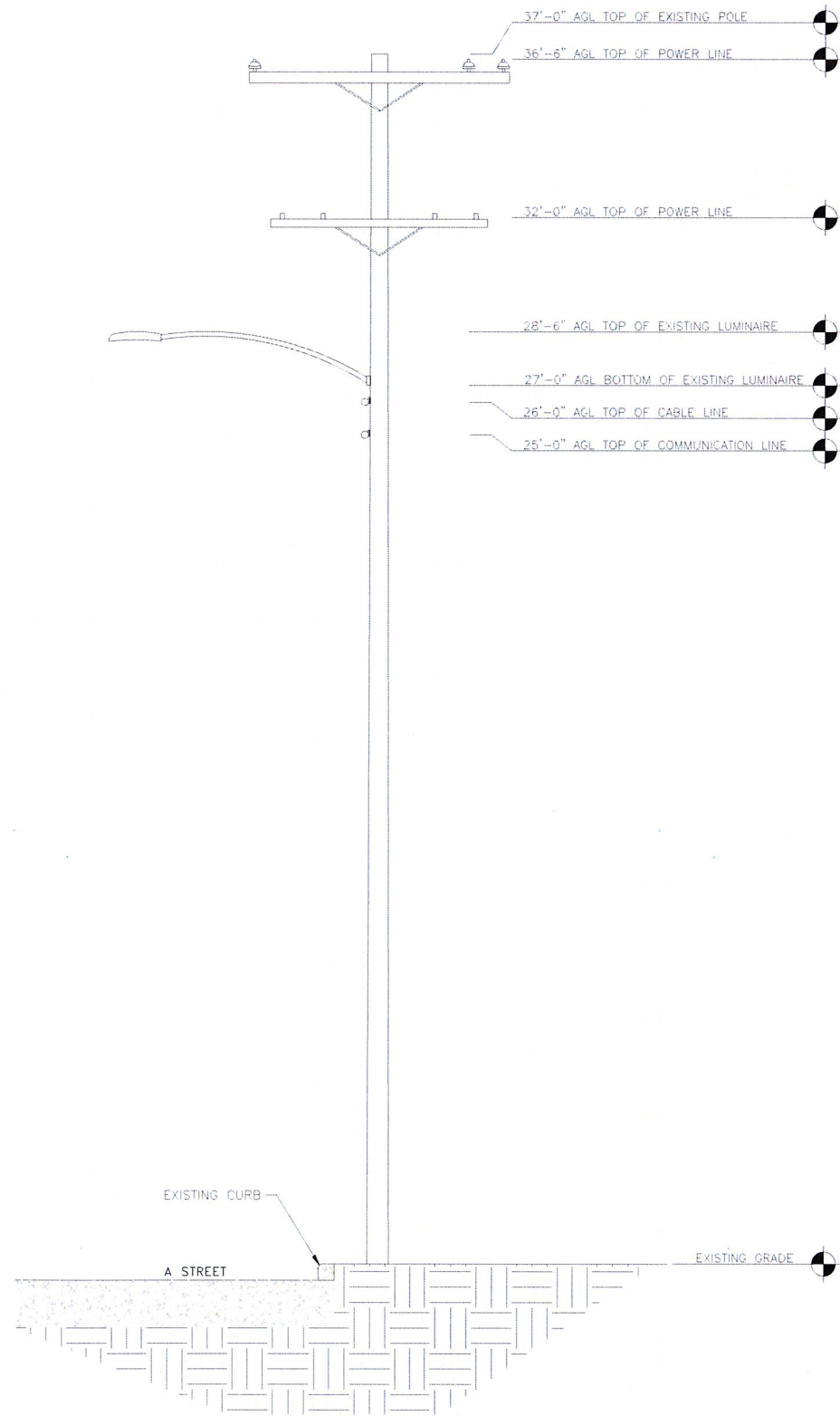

EXISTING SOUTHEAST ELEVATION

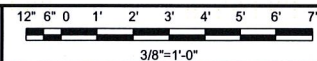

1

NOTES

1. ALL PROPOSED EQUIPMENT TO BE PAINTED TO MATCH EXISTING CONDITIONS.
2. DISTANCE FROM ANTENNA FACE TO NEAREST BUILDING (1301 90TH AVE). SEE SHEET C-1 FOR ORIENTATION.

CARRIER MAKE-READY

1. CONTRACTOR TO INSTALL CANISTER ANTENNA w/ ANCILLARY ELECTRONICS AND HARDWARE ON PROPOSED ANTENNA SUPPORT ARM.
2. CONTRACTOR TO INSTALL (2) RADIOS w/ ANCILLARY ELECTRONICS AND HARDWARE ON PROPOSED CHANNEL MOUNTS.
3. CONTRACTOR TO INSTALL (1) 2" SCH. 80 PVC RISER CONDUIT FOR COAX AND FIBER CABLES.
4. CONTRACTOR TO INSTALL (1) BREAKER BOX/LOAD CENTER ON PROPOSED CHANNEL MOUNTS.
5. CONTRACTOR TO INSTALL (1) PG&E SMART METER.
6. CONTRACTOR TO INSTALL (1) 1.25" SCH. 80 PVC RISER WITH WEATHERHEAD FOR POWER.
7. EXTENET APPROVED CONTRACTOR TO INSTALL (1) NEW FIBER OPTIC LINE AT 23'-6".
8. CONTRACTOR TO INSTALL REQUIRED RF SIGNAGE 3'-0" BELOW PROPOSED ANTENNA MOUNT.

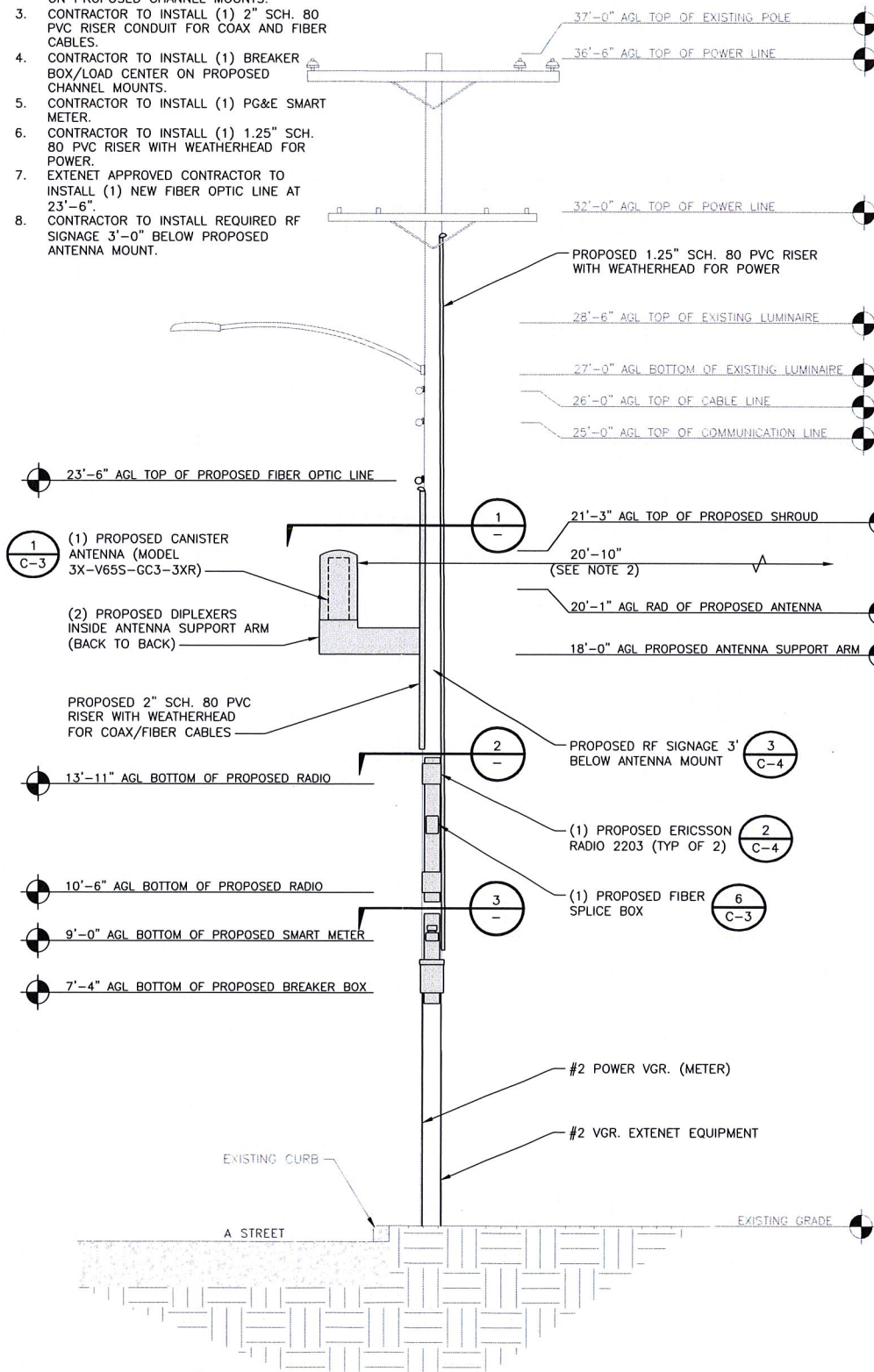

PROPOSED SOUTHEAST ELEVATION

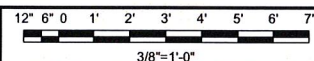

2

NOTE

LUMINAIRE NOT SHOWN FOR CLARITY.

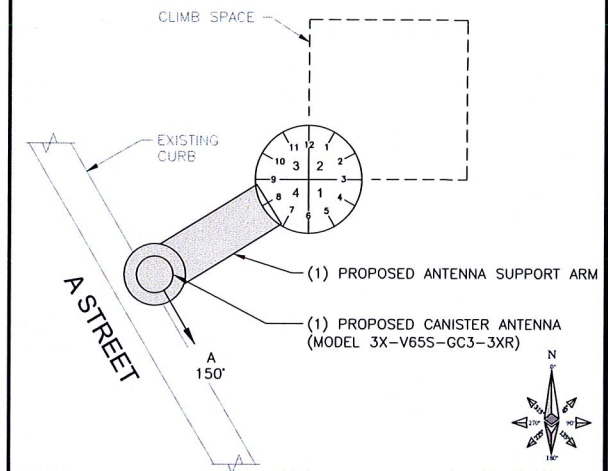

ANTENNA SPACE PLAN VIEW

NO SCALE

3

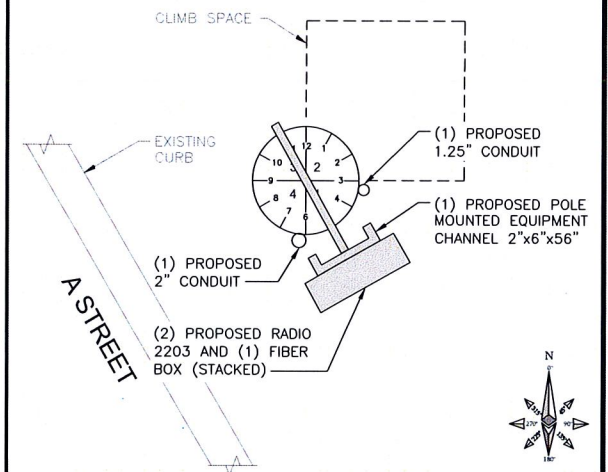

RADIO SPACE PLAN VIEW

NO SCALE

4

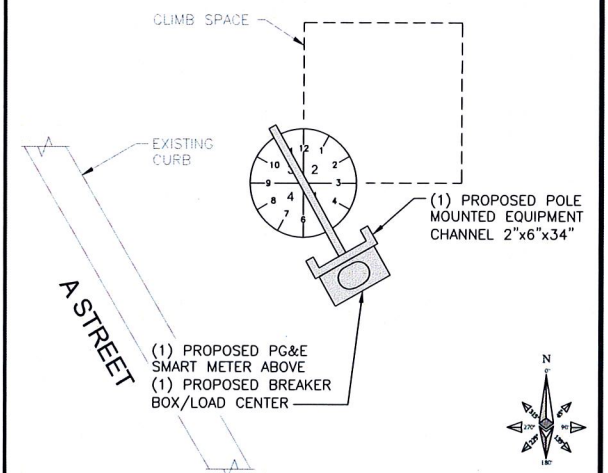

EQUIPMENT PLAN VIEW

NO SCALE

5



INTERNAL REVIEW

CONSTRUCTION SIGNATURE DATE

RF SIGNATURE DATE

REAL ESTATE SIGNATURE DATE



BLACK & VEATCH

BLACK & VEATCH CORPORATION
7760 FRANCE AVE
SUITE 1200
BLOOMINGTON, MN 55435

THESE DRAWINGS ARE COPYRIGHTED AND ARE THE PROPERTY OF BLACK & VEATCH; PRODUCED SOLELY FOR THE USE OF OUR CLIENT. ANY REPRODUCTION OR USE OF THE INFORMATION CONTAINED WITHIN SAID DRAWINGS IS PROHIBITED WITHOUT WRITTEN CONSENT BY BLACK & VEATCH.

PROJECT NO.	DRAWN BY	CHECKED BY
192417.4381	DLG	GAC

REV	DATE	DESCRIPTION
B	09/27/16	ISSUED FOR REVIEW
A	09/27/16	ISSUED FOR REVIEW

PRELIMINARY

IT IS A VIOLATION OF LAW FOR ANY PERSON, UNLESS THEY ARE ACTING UNDER THE DIRECTION OF A LICENSED PROFESSIONAL ENGINEER, TO ALTER THIS DOCUMENT.

EXTENET SYSTEMS (CA) LLC
2000 CROW CANYON PLACE
SUITE 210
SAN RAMON, CA 94583

SITE ADDRESS
ADJACENT TO (IN PROW)
1301 90TH AVENUE
OAKLAND, CA 94603

SHEET TITLE
UTILITY POLE ELEVATIONS
AND RISER DETAILS

SHEET NUMBER
C-2

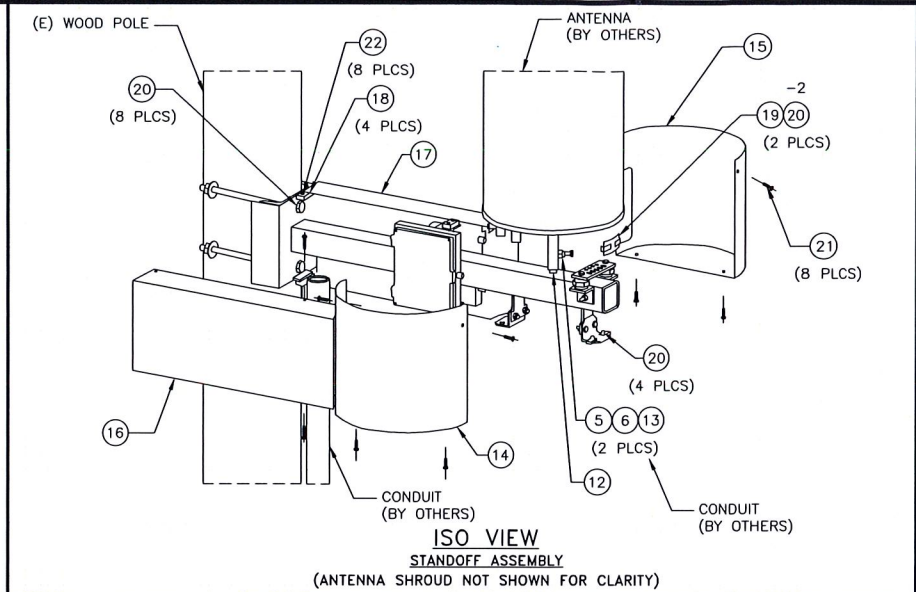
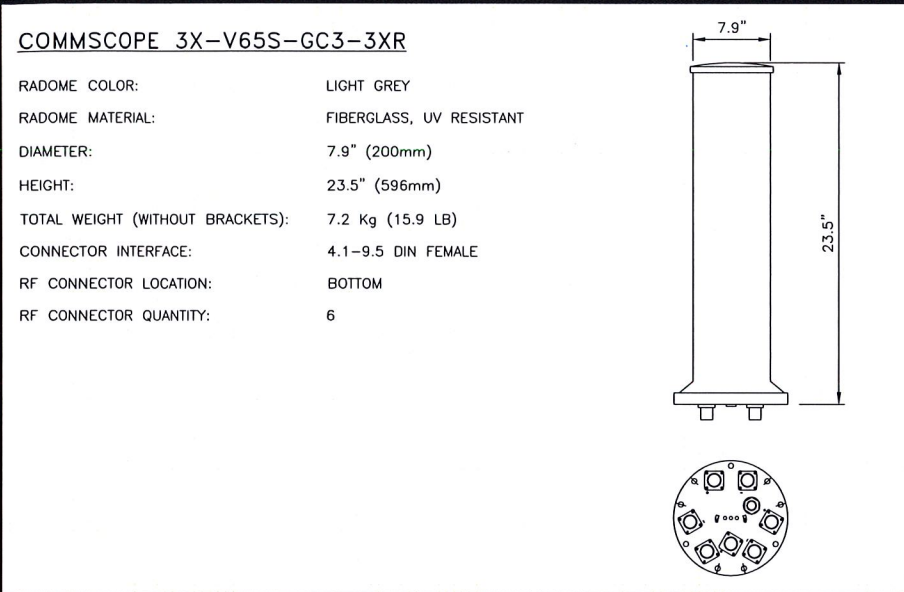

ITEM #	PART #	DESCRIPTION	QTY.	UNIT WT. (lbs)
STANDOFF ARM ASSEMBLY PARTS/HWDR				
1	WA-714	3"x3"x3/16"x3"-2" STANDOFF ARM WLDMNT	1	43
2	SS-514	2"x2"x1/4"x2" A36, ANGLE	2	0.5
3	SS-516	2"x2"x1/8"x3" A36, ANGLE	2	0.4
4	15230	3/8"x1" A307 FULLY THD'D BOLT/NUT/LW, GALV.	4	0.1
5	41010	3/8"x1" A563-A HEX NUT, GALV.	2	0.01
6	51000	3/8"x1" A563-A HEX NUT, GALV.	2	0.01
7	80326	3/8"x6" A36 THRD ROD, GALV.	1	0.19
BUS BAR ASSEMBLY PARTS / HWDR				
8	PL-718	1/4"x2"x6" COPPER, BUS BAR	1	0.8
9	43010	3/8" LOCK COPPER, BUS BAR	4	0.01
10	71017	3/8"x5/8" FULLY THD'D S.S. BOLT	4	0.04
11	90060	3/8" STANDOFF INSULATOR (559640)	2	0.1
ANTENNA / EQUIPMENT MOUNT PARTS / HWDR				
12	WA-698	3/8"x7" O.D. A36, TOP CAP WLDMNT	1	2.2
13	16250F	3/8"x1 1/2" A307 FULLY THD'D BOLT, GALV.	2	0.1
14	41010	3/8" LOCK WASHER, GALV.	2	0.01
15	51000	3/8" A563 HEX NUT, GALV.	2	0.02
SHROUD ASSEMBLY PARTS / HWDR				
14	WA-715L	14GA.x13 1/16"x14 5/8" I.D. E.G., FORMED PLATE WLDMNT	1	8
15	WA-715R	14GA.x13 1/16"x14 5/8" I.D. E.G., FORMED PLATE WLDMNT	1	8
16	PL-1264	14GA.x17 5/8"x2"-0 7/8" E.G., FORMED COVER	1	9.9
17	PL-1267	14GA.x17 5/8"x2"-0 15/16" E.G., FORMED COVER	1	0.3
18	PL-1581	1/2"x1"x2" A36, PLATE	4	0.3
19	14209-4	11GA.x1 1 1/2"x2 15/16" A36, FORMED PLATE	2	0.1
20	55500	1/4-20 U-STYLE SPEED NUT, BLACK PHOSPHATE	16	0.02
21	70217	1/4"x1" SS FLGD BUTTON-HD SCKT CAP SCRW	18	0.02
22	70218	1/4"x1 1/4" SS FLGD BUTTON-HD SCKT CAP SCRW	18	0.003
				TOTAL GALV. WT. = 89lbs

PROPOSED ANTENNA NO SCALE 1

SIDE ARM ANTENNA MOUNT 2'-0" STANDOFF FOR WOOD POLE NO SCALE 2

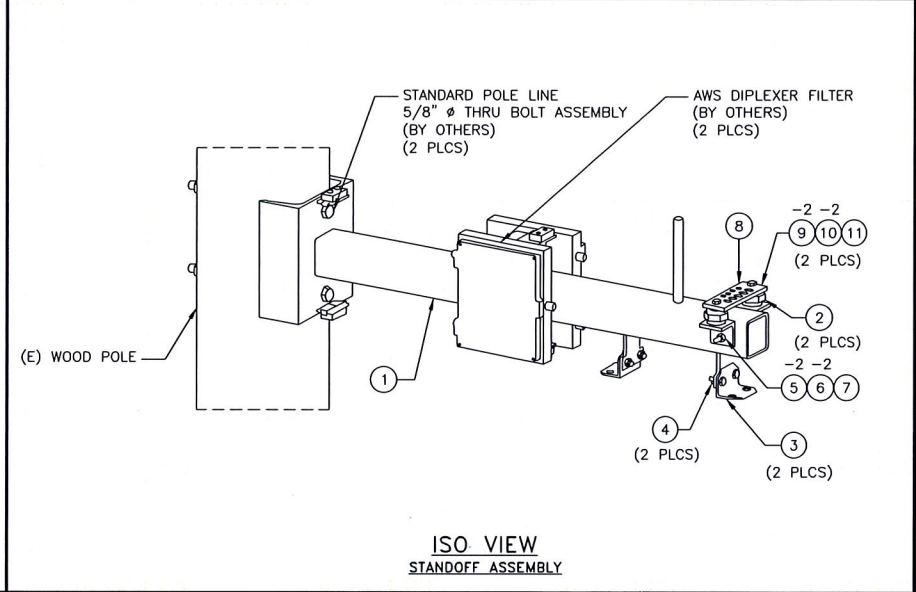
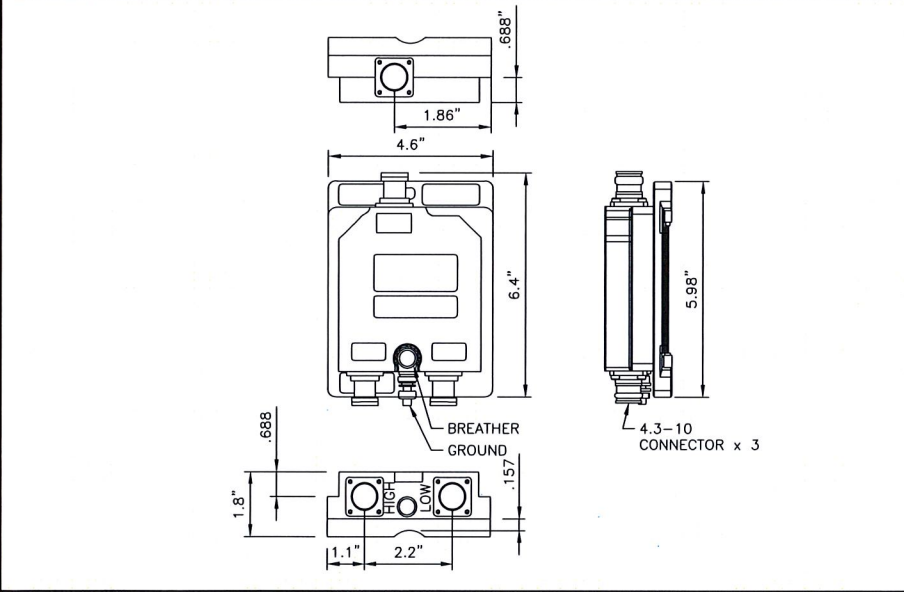

ANTENNA SHROUD PARTS TABLE NO SCALE 3

F1-4868-FSS FUSION SPlice ENCLOSURE

DEPTH: 2 1/8" (D) 4 3/4"

HEIGHT: 6 3/4" (H)

WIDTH: 4 3/4" (W)

COMMSCOPE CBC 1923-4310/ E11F13P20 NO SCALE 4

SIDE ARM ANTENNA MOUNT 2'-0" STANDOFF FOR WOOD POLE NO SCALE 5

FIBER SPlice BOX NO SCALE 6

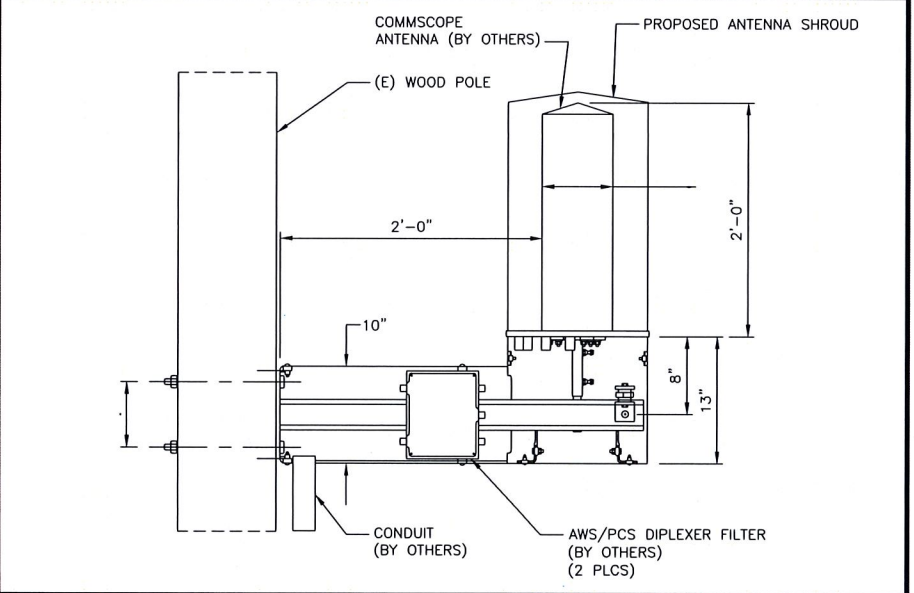
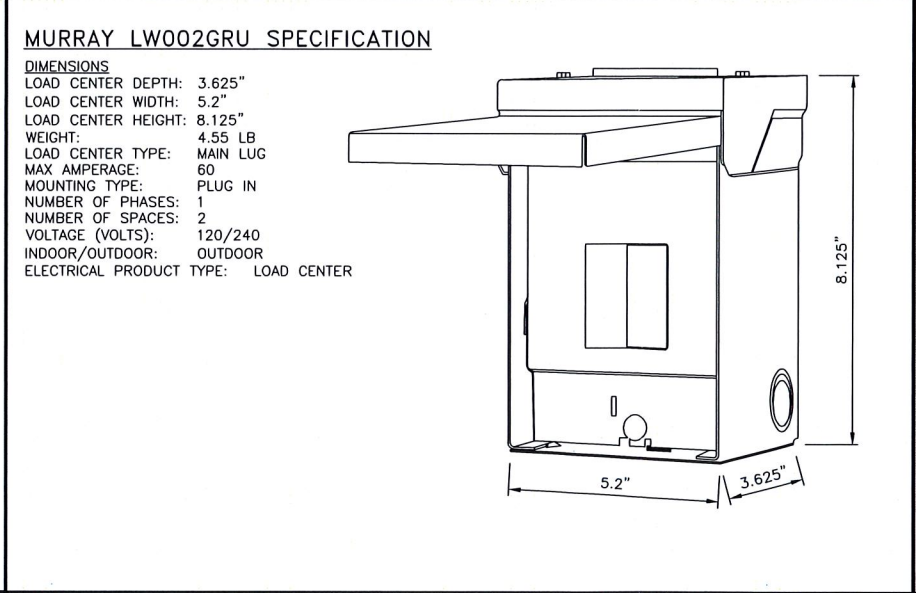
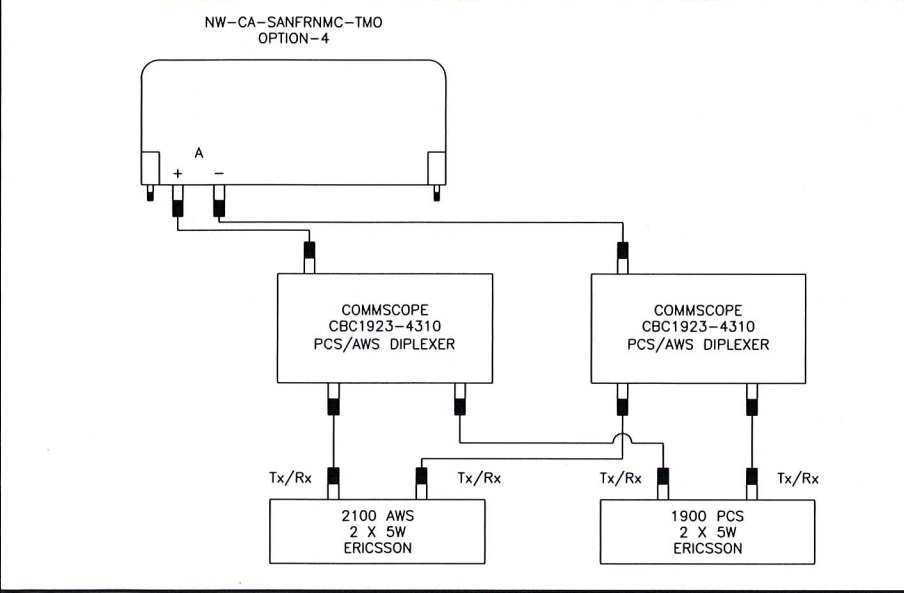

ANTENNA CONFIGURATION NO SCALE 7

MURRAY LW002GRU NO SCALE 8

SIDE ARM ANTENNA MOUNT 2'-0" STANDOFF FOR WOOD POLE NO SCALE 9



INTERNAL REVIEW

CONSTRUCTION SIGNATURE DATE

RF SIGNATURE DATE

REAL ESTATE SIGNATURE DATE

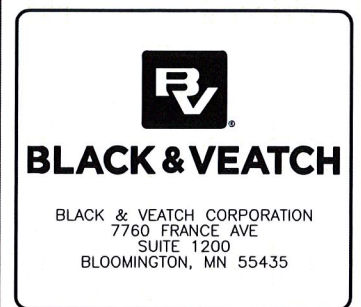

THESE DRAWINGS ARE COPYRIGHTED AND ARE THE PROPERTY OF BLACK & VEATCH; PRODUCED SOLELY FOR THE USE OF OUR CLIENT. ANY REPRODUCTION OR USE OF THE INFORMATION CONTAINED WITHIN SAID DRAWINGS IS PROHIBITED WITHOUT WRITTEN CONSENT BY BLACK & VEATCH.

PROJECT NO.	DRAWN BY	CHECKED BY
192417.4381	DLG	GAC

REV	DATE	DESCRIPTION
B	09/27/16	ISSUED FOR REVIEW
A	09/27/16	ISSUED FOR REVIEW

PRELIMINARY

IT IS A VIOLATION OF LAW FOR ANY PERSON, UNLESS THEY ARE ACTING UNDER THE DIRECTION OF A LICENSED PROFESSIONAL ENGINEER, TO ALTER THIS DOCUMENT.

EXTENET SYSTEMS (CA) LLC
 2000 CROW CANYON PLACE
 SUITE 210
 SAN RAMON, CA 94583

SITE ADDRESS
 ADJACENT TO (IN PROW)
 1301 90TH AVENUE
 OAKLAND, CA 94603

SHEET TITLE
 EQUIPMENT DETAILS

SHEET NUMBER
C-3

INTERNAL REVIEW	
CONSTRUCTION SIGNATURE	DATE
RF SIGNATURE	DATE
REAL ESTATE SIGNATURE	DATE



BLACK & VEATCH

BLACK & VEATCH CORPORATION
7760 FRANCE AVE
SUITE 1200
BLOOMINGTON, MN 55435

THESE DRAWINGS ARE COPYRIGHTED AND ARE THE PROPERTY OF BLACK & VEATCH; PRODUCED SOLELY FOR THE USE OF OUR CLIENT. ANY REPRODUCTION OR USE OF THE INFORMATION CONTAINED WITHIN SAID DRAWINGS IS PROHIBITED WITHOUT WRITTEN CONSENT BY BLACK & VEATCH.

PROJECT NO.	DRAWN BY	CHECKED BY
192417.4381	DLG	GAC

REV	DATE	DESCRIPTION
B	09/27/16	ISSUED FOR REVIEW
A	09/27/16	ISSUED FOR REVIEW

PRELIMINARY

IT IS A VIOLATION OF LAW FOR ANY PERSON, UNLESS THEY ARE ACTING UNDER THE DIRECTION OF A LICENSED PROFESSIONAL ENGINEER, TO ALTER THIS DOCUMENT.

EXTENET SYSTEMS (CA) LLC
2000 CROW CANYON PLACE
SUITE 210
SAN RAMON, CA 94583

SITE ADDRESS
ADJACENT TO (IN PROW)
1301 90TH AVENUE
OAKLAND, CA 94603

SHEET TITLE
EQUIPMENT DETAILS

SHEET NUMBER
C-4

NOT USED	NO SCALE	4
----------	----------	---

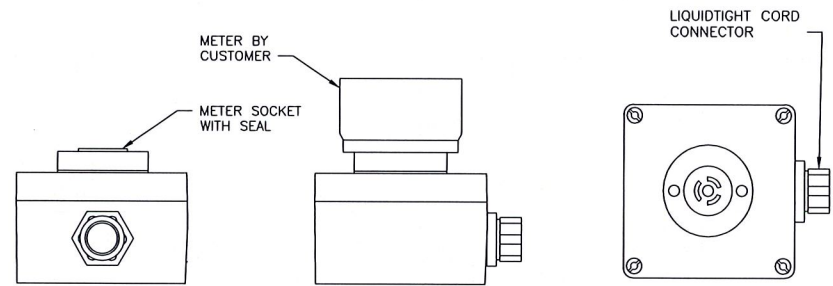

PROPOSED METER ADAPTER	NO SCALE	5
------------------------	----------	---

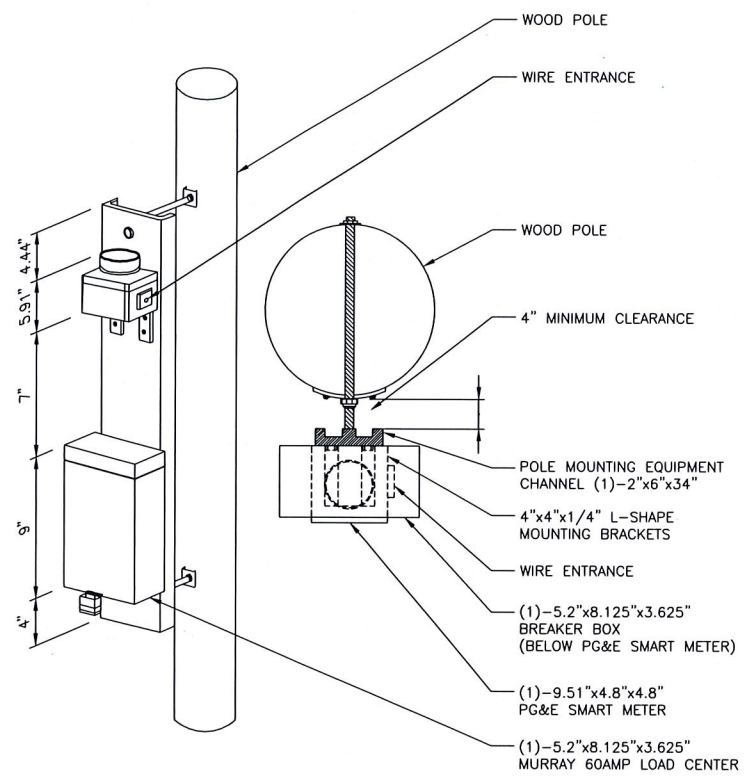

SMART METER/BREAKER BOX DETAIL	NO SCALE	6
--------------------------------	----------	---

NOT USED	NO SCALE	1
----------	----------	---

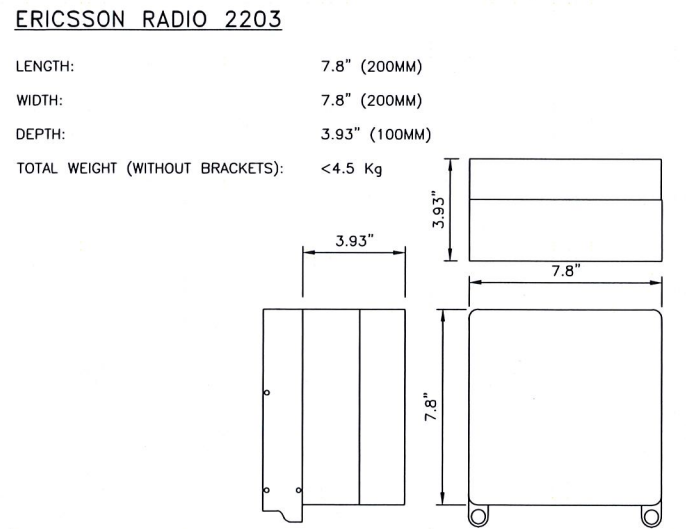

RADIO SPECIFICATION DETAIL	NO SCALE	2
----------------------------	----------	---

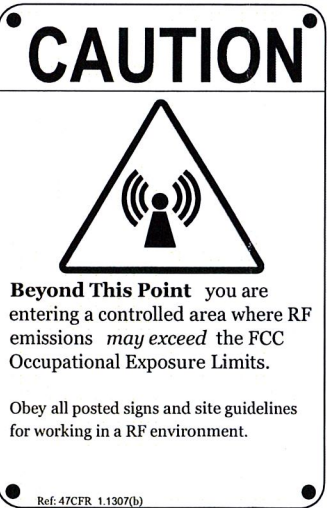
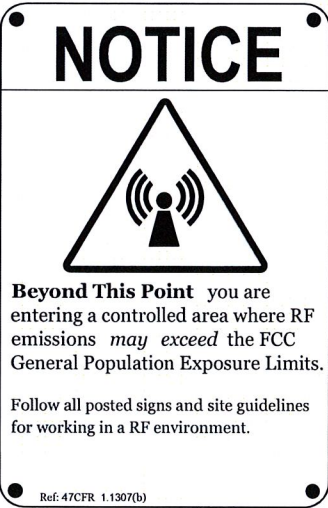

NOTE: SPECIFIC EME PLACARD WILL BE PLACED AFTER EME REPORT

RF SIGNAGE DETAIL	NO SCALE	3
-------------------	----------	---

ATTACHMENT D

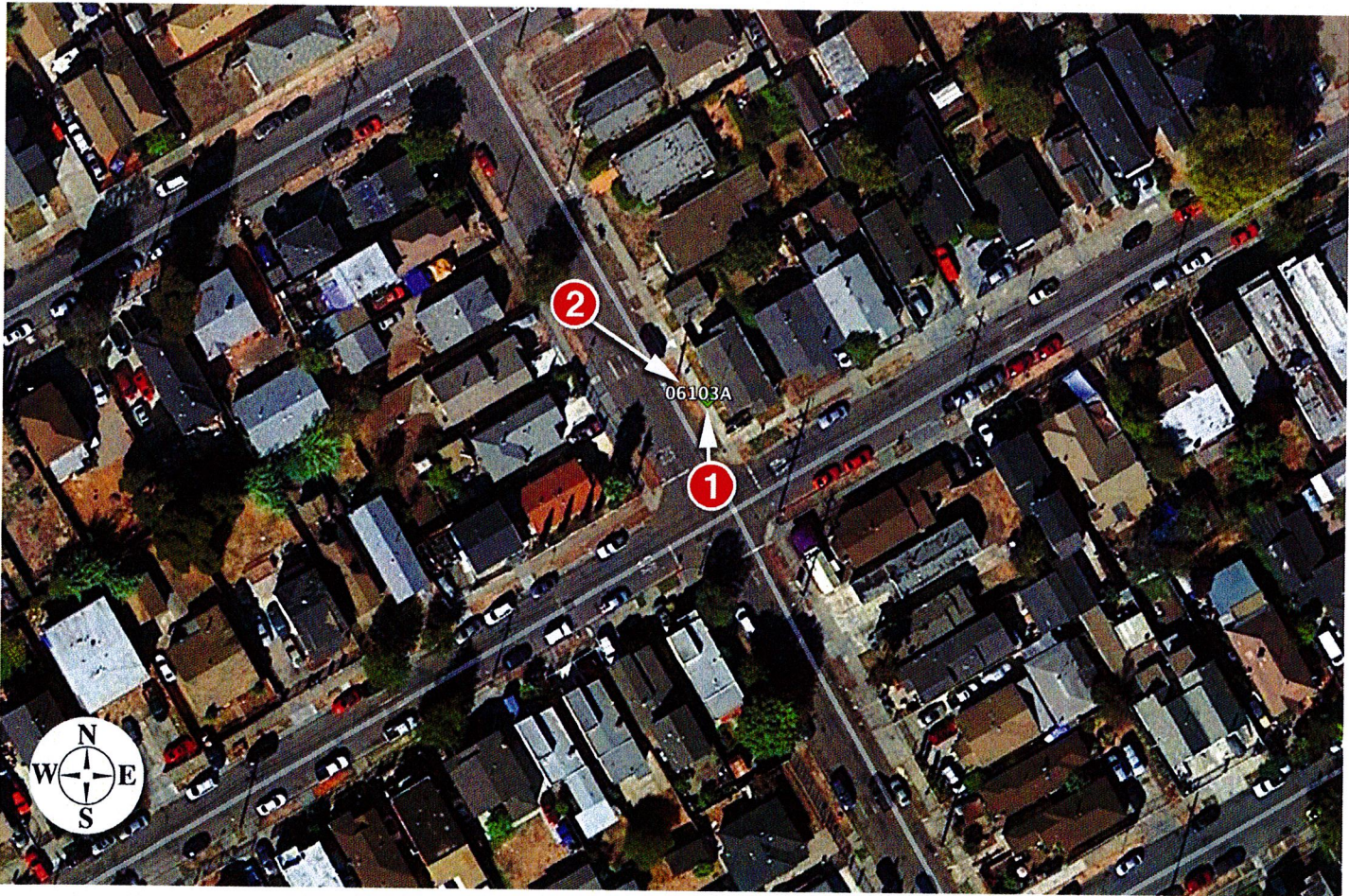

NW-CA-SANFRNMC 06103A

Aerial Map

9/26/16

Adjacent to (IN PROW)
1301 90th Avenue Oakland, CA

Applied Imagination 510 914-0500



Existing



proposed antenna

Proposed



Existing



proposed antenna

Proposed

ATTACHMENT E



EXTENET OAKLAND NODE 06103A ALTERNATIVE SITE ANALYSIS

MAP OF ALTERNATIVE POLES EVALUATED FOR NODE 06103A



- The above maps depict ExteneNet's proposed Node06103A in relation to other poles in the area that were evaluated as possibly being viable alternative candidates.
- The following is an analysis of each of those 3 alternative locations.

PROPAGATION MAP OF NODES 06103A

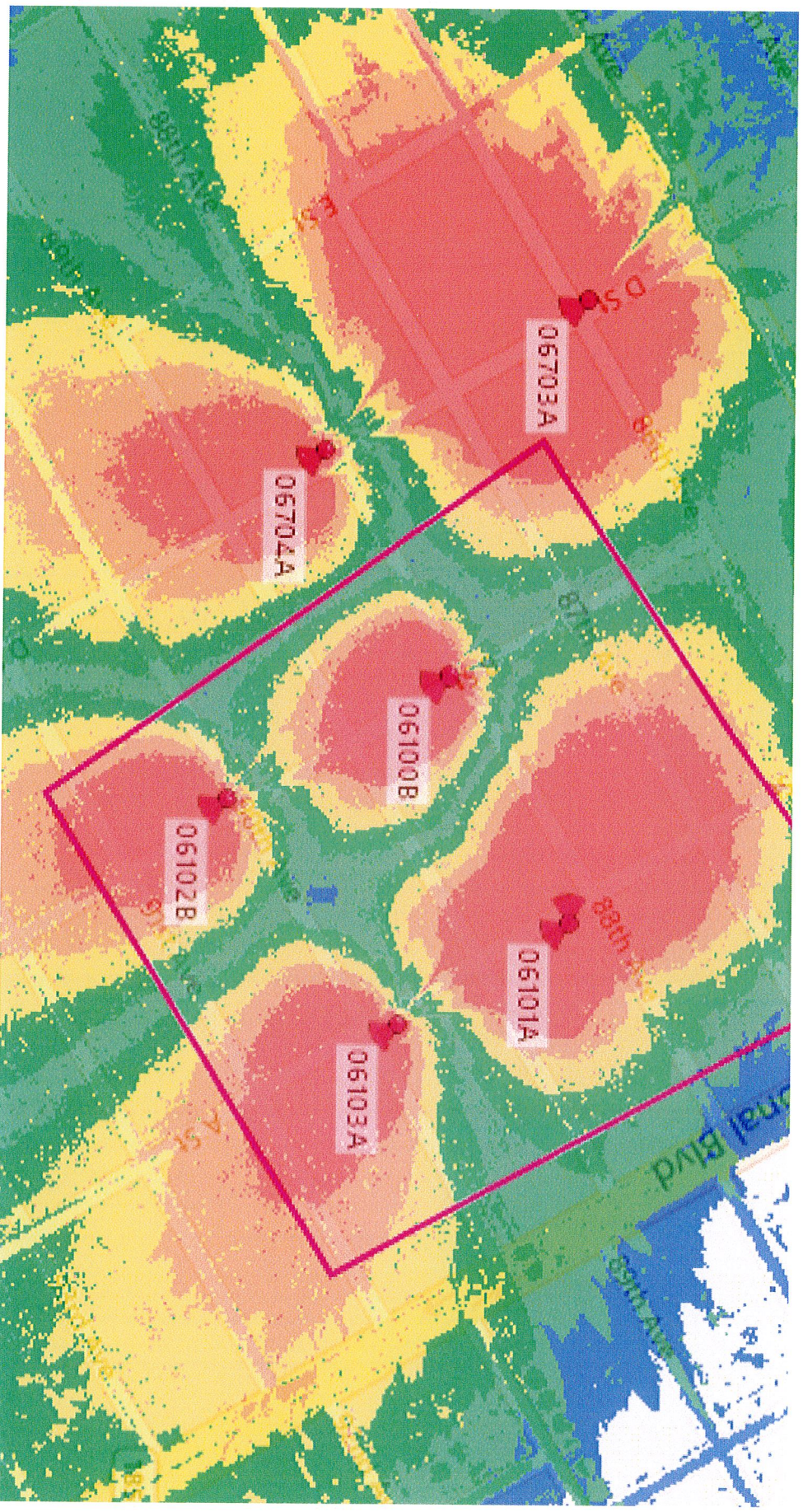

This propagation map depicts the ExteNet proposed Node 06103A in relation to surrounding proposed ExteNet small cell nodes.

06103A - PROPOSED LOCATION



- The location for ExteneNet's proposed Node 06103A is a joint utility pole located adjacent to PROW at 1301 90th Avenue (37.749173, -122.176401).
- ExteneNet's objective is to provide T-Mobile 4G wireless coverage and capacity to the Oakland area.
- ExteneNet evaluated this site and nearby alternatives to verify that the selected site is the least intrusive means to close T-Mobile's significant service coverage gap.

ALTERNATIVE NODE 06103B



- Node 06103B is a joint utility pole next to 1306 90th Avenue (37.749006, -122.176250).
- This pole is not a viable alternative candidate because placing wireless equipment on this pole would likely violate CPUC General Order-95 Regulation because all four quadrants of the pole appear occupied.
- This pole is not a viable alternative candidate because cross lines and cross arms prevent adequate climbing space on the pole pursuant to CPUC General Order 95, thus prohibiting a wireless facility from being installed at this location.
- This pole is not a viable alternative candidate because this pole is located too close to primary Node 06101A.

ALTERNATIVE NODE 06103C



- Node 06103C is a joint utility pole at 1316 90th Avenue (37.749142, -122.175941)
- This pole is not a viable alternative candidate because placing wireless equipment on this pole would likely violate CPUC General Order-95 Regulation because all four quadrants of the pole appear occupied.
- This pole is not a viable alternative candidate because this pole is located too close to primary Node 06101A.

ALTERNATIVE NODE 06103D



- Node 06103D is a joint utility pole near 9006 A Street (37.748905, -122.176136).
- This pole is not a viable alternative candidate because cross lines and cross arms prevent adequate climbing space on the pole pursuant to CPUC General Order 95, thus prohibiting a wireless facility from being installed at this location.
- This pole is not a viable alternative candidate because the existing riser on the pole occupies the available quadrant space.
- This pole is not a viable alternative candidate because placing wireless equipment on this pole would likely violate CPUC General Order-95 Regulation because all four quadrants of the pole appear occupied.
- This pole is not a viable alternative candidate because this pole is located too close to primary Node 06102B.
- This pole is not a viable alternative candidate because this pole is located too far from primary Node 06101A.

ALTERNATIVE SITE ANALYSIS CONCLUSION

Based on ExteneNet's analysis of alternative sites, the currently proposed Node 06103A is the least intrusive location from which to fill the surrounding significant wireless coverage gaps.

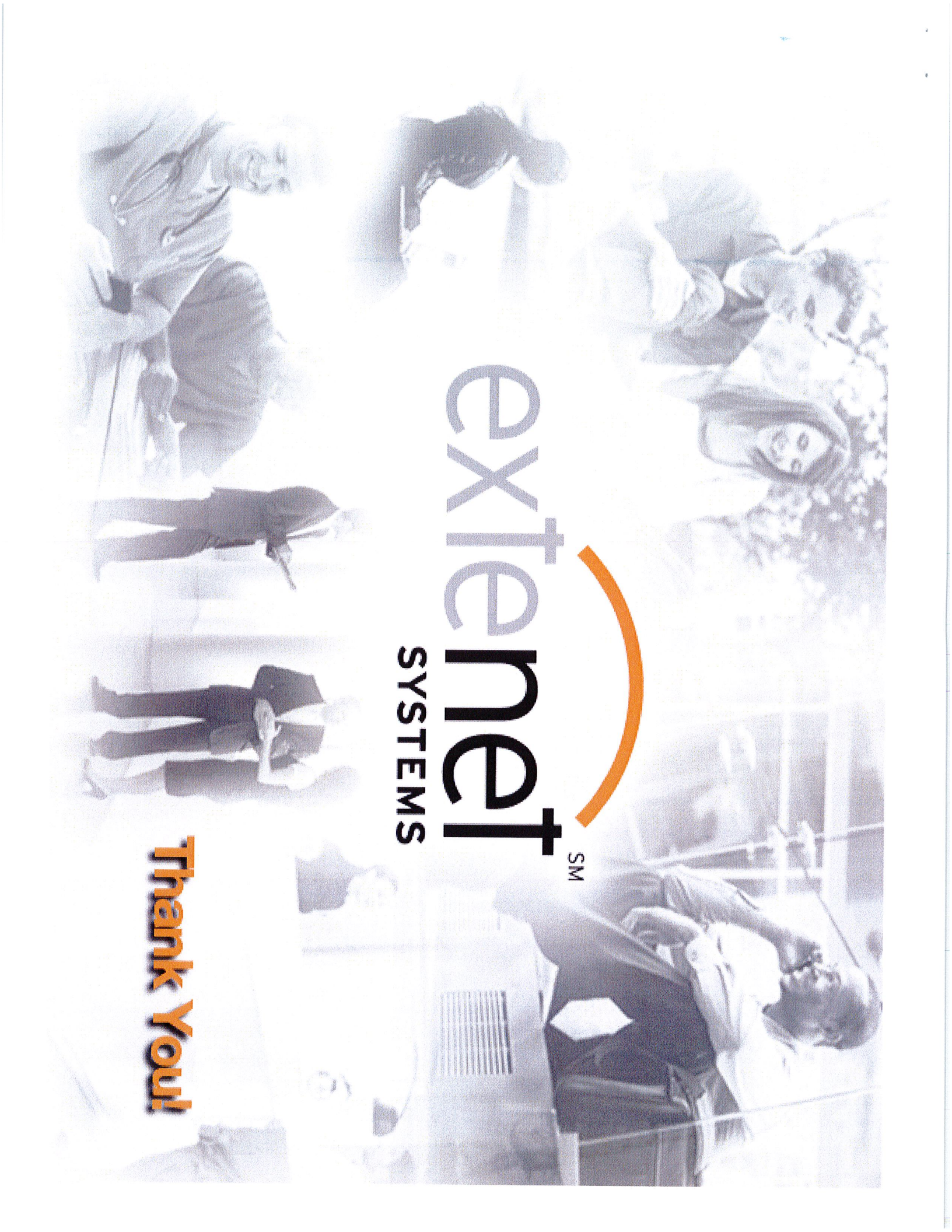

extenet
SM
SYSTEMS

Thank You!

**ExteNet Systems CA, LLC • Proposed DAS Node (Site No. 06103A)
1301 90th Avenue • Oakland, California**

Statement of Hammett & Edison, Inc., Consulting Engineers

The firm of Hammett & Edison, Inc., Consulting Engineers, has been retained on behalf of ExteNet Systems CA, LLC, a wireless telecommunications carrier, to evaluate the addition of Node No. 06103A to be added to the ExteNet distributed antenna system (“DAS”) in Oakland, California, for compliance with appropriate guidelines limiting human exposure to radio frequency (“RF”) electromagnetic fields.

Executive Summary

ExteNet proposes to install a directional panel antenna on a utility pole sited in the public right-of-way at 1301 90th Avenue in Oakland. The proposed operation will comply with the FCC guidelines limiting public exposure to RF energy.

Prevailing Exposure Standards

The U.S. Congress requires that the Federal Communications Commission (“FCC”) evaluate its actions for possible significant impact on the environment. A summary of the FCC’s exposure limits is shown in Figure 1. These limits apply for continuous exposures and are intended to provide a prudent margin of safety for all persons, regardless of age, gender, size, or health. The most restrictive FCC limit for exposures of unlimited duration to radio frequency energy for several personal wireless services are as follows:

Wireless Service	Frequency Band	Occupational Limit	Public Limit
Microwave (Point-to-Point)	5,000–80,000 MHz	5.00 mW/cm ²	1.00 mW/cm ²
BRS (Broadband Radio)	2,600	5.00	1.00
AWS (Advanced Wireless)	2,100	5.00	1.00
PCS (Personal Communication)	1,950	5.00	1.00
Cellular	870	2.90	0.58
SMR (Specialized Mobile Radio)	855	2.85	0.57
700 MHz	700	2.35	0.47
[most restrictive frequency range]	30–300	1.00	0.20

Power line frequencies (60 Hz) are well below the applicable range of these standards, and there is considered to be no compounding effect from simultaneous exposure to power line and radio frequency fields.

General Facility Requirements

Base stations typically consist of two distinct parts: the electronic transceivers (also called “radios” or “channels”) that are connected to the traditional wired telephone lines, and the passive antennas that send the wireless signals created by the radios out to be received by individual subscriber units. The transceivers are often located at ground level and are connected to the antennas by coaxial cables.

**ExteNet Systems CA, LLC • Proposed DAS Node (Site No. 06103A)
1301 90th Avenue • Oakland, California**

A small antenna for reception of GPS signals is also required, mounted with a clear view of the sky. Because of the short wavelength of the frequencies assigned by the FCC for wireless services, the antennas require line-of-sight paths for their signals to propagate well and so are installed at some height above ground. The antennas are designed to concentrate their energy toward the horizon, with very little energy wasted toward the sky or the ground. This means that it is generally not possible for exposure conditions to approach the maximum permissible exposure limits without being physically very near the antennas.

Computer Modeling Method

The FCC provides direction for determining compliance in its Office of Engineering and Technology Bulletin No. 65, "Evaluating Compliance with FCC-Specified Guidelines for Human Exposure to Radio Frequency Radiation," dated August 1997. Figure 2 attached describes the calculation methodologies, reflecting the facts that a directional antenna's radiation pattern is not fully formed at locations very close by (the "near-field" effect) and that at greater distances the power level from an energy source decreases with the square of the distance from it (the "inverse square law"). The conservative nature of this method for evaluating exposure conditions has been verified by numerous field tests.

Site and Facility Description

Based upon information provided by ExteNet, including drawings by Black & Veatch Corporation, dated September 27, 2016, it is proposed to install one CommScope Model 3X-V65S-GC3-3XR, 2-foot tall, tri-directional cylindrical antenna, with one direction activated, on a cross-arm to be added to a utility pole sited in the public right-of-way in front of the residence located at 1301 90th Avenue in Oakland. The antenna would employ no downtilt, would be mounted at an effective height of about 20 feet above ground, and its principal direction would be oriented toward 150°T. T-Mobile proposes to operate from this facility with a maximum effective radiated power in any direction of 214 watts, representing simultaneous operation 107 watts for AWS and 107 watts for PCS service. There are reported no other wireless telecommunications base stations at this site or nearby.

Study Results

For a person anywhere at ground, the maximum RF exposure level due to the proposed T-Mobile operation is calculated to be 0.0046 mW/cm², which is 0.46% of the applicable public exposure limit. The maximum calculated level at the second-floor elevation of any nearby building is 2.8% of the public exposure limit. It should be noted that these results include several "worst-case" assumptions and therefore are expected to overstate actual power density levels from the proposed operation.



**ExteNet Systems CA, LLC • Proposed DAS Node (Site No. 06103A)
1301 90th Avenue • Oakland, California**

Recommended Mitigation Measures

Due to its mounting location and height, the ExteNet antenna would not be accessible to the general public, and so no mitigation measures are necessary to comply with the FCC public exposure guidelines. To prevent occupational exposures in excess of the FCC guidelines, it is recommended that appropriate RF safety training be provided to all authorized personnel who have access to the antenna, including employees and contractors of the utility companies. No access within 2 feet directly in front of the antenna itself, such as might occur during certain activities, should be allowed while the base station is in operation, unless other measures can be demonstrated to ensure that occupational protection requirements are met. Posting explanatory signs* on the pole at or below the antenna, such that the signs would be readily visible from any angle of approach to persons who might need to work within that distance, would be sufficient to meet FCC-adopted guidelines.

Conclusion

Based on the information and analysis above, it is the undersigned's professional opinion that operation of the node proposed by ExteNet Systems CA, LLC, at 1301 90th Avenue in Oakland, California, will comply with the prevailing standards for limiting public exposure to radio frequency energy and, therefore, will not for this reason cause a significant impact on the environment. The highest calculated level in publicly accessible areas is much less than the prevailing standards allow for exposures of unlimited duration. This finding is consistent with measurements of actual exposure conditions taken at other operating base stations. Training personnel and posting signs is recommended to establish compliance with occupational exposure limitations.

Authorship

The undersigned author of this statement is a qualified Professional Engineer, holding California Registration No. E-18063, which expires on June 30, 2017. This work has been carried out under his direction, and all statements are true and correct of his own knowledge except, where noted, when data has been supplied by others, which data he believes to be correct.

Rajat Mathur, P.E.
707/996-5200



October 10, 2016

* Signs should comply with OET-65 color, symbol, and content recommendations. Contact information should be provided (e.g., a telephone number) to arrange for access to restricted areas. The selection of language(s) is not an engineering matter, and guidance from the landlord, local zoning or health authority, or appropriate professionals may be required. Signage may also need to comply with the requirements of California Public Utilities Commission General Order No. 95.

FCC Radio Frequency Protection Guide

The U.S. Congress required (1996 Telecom Act) the Federal Communications Commission (“FCC”) to adopt a nationwide human exposure standard to ensure that its licensees do not, cumulatively, have a significant impact on the environment. The FCC adopted the limits from Report No. 86, “Biological Effects and Exposure Criteria for Radiofrequency Electromagnetic Fields,” published in 1986 by the Congressionally chartered National Council on Radiation Protection and Measurements (“NCRP”). Separate limits apply for occupational and public exposure conditions, with the latter limits generally five times more restrictive. The more recent standard, developed by the Institute of Electrical and Electronics Engineers and approved as American National Standard ANSI/IEEE C95.1-2006, “Safety Levels with Respect to Human Exposure to Radio Frequency Electromagnetic Fields, 3 kHz to 300 GHz,” includes similar limits. These limits apply for continuous exposures from all sources and are intended to provide a prudent margin of safety for all persons, regardless of age, gender, size, or health.

As shown in the table and chart below, separate limits apply for occupational and public exposure conditions, with the latter limits (in *italics* and/or dashed) up to five times more restrictive:

Frequency Applicable Range (MHz)	Electromagnetic Fields (<i>f</i> is frequency of emission in MHz)					
	Electric Field Strength (V/m)		Magnetic Field Strength (A/m)		Equivalent Far-Field Power Density (mW/cm ²)	
0.3 – 1.34	614	<i>614</i>	1.63	<i>1.63</i>	100	<i>100</i>
1.34 – 3.0	614	<i>823.8/f</i>	1.63	<i>2.19/f</i>	100	<i>180/f²</i>
3.0 – 30	1842/f	<i>823.8/f</i>	4.89/f	<i>2.19/f</i>	900/f ²	<i>180/f²</i>
30 – 300	61.4	<i>27.5</i>	0.163	<i>0.0729</i>	1.0	<i>0.2</i>
300 – 1,500	3.54√ <i>f</i>	<i>1.59√f</i>	√ <i>f</i> /106	<i>√f/238</i>	f/300	<i>f/1500</i>
1,500 – 100,000	137	<i>61.4</i>	0.364	<i>0.163</i>	5.0	<i>1.0</i>

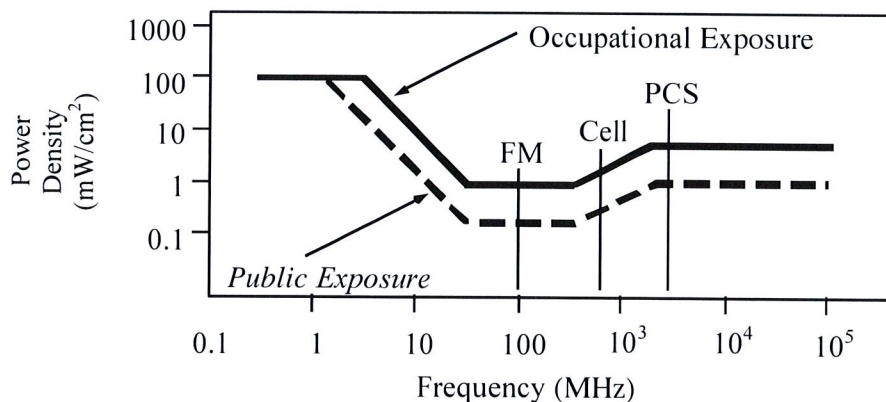

Higher levels are allowed for short periods of time, such that total exposure levels averaged over six or thirty minutes, for occupational or public settings, respectively, do not exceed the limits, and higher levels also are allowed for exposures to small areas, such that the spatially averaged levels do not exceed the limits. However, neither of these allowances is incorporated in the conservative calculation formulas in the FCC Office of Engineering and Technology Bulletin No. 65 (August 1997) for projecting field levels. Hammett & Edison has built those formulas into a proprietary program that calculates, at each location on an arbitrary rectangular grid, the total expected power density from any number of individual radio sources. The program allows for the description of buildings and uneven terrain, if required to obtain more accurate projections.



RFR.CALC™ Calculation Methodology

Assessment by Calculation of Compliance with FCC Exposure Guidelines

The U.S. Congress required (1996 Telecom Act) the Federal Communications Commission (“FCC”) to adopt a nationwide human exposure standard to ensure that its licensees do not, cumulatively, have a significant impact on the environment. The maximum permissible exposure limits adopted by the FCC (see Figure 1) apply for continuous exposures from all sources and are intended to provide a prudent margin of safety for all persons, regardless of age, gender, size, or health. Higher levels are allowed for short periods of time, such that total exposure levels averaged over six or thirty minutes, for occupational or public settings, respectively, do not exceed the limits.

Near Field.

Prediction methods have been developed for the near field zone of panel (directional) and whip (omnidirectional) antennas, typical at wireless telecommunications base stations, as well as dish (aperture) antennas, typically used for microwave links. The antenna patterns are not fully formed in the near field at these antennas, and the FCC Office of Engineering and Technology Bulletin No. 65 (August 1997) gives suitable formulas for calculating power density within such zones.

For a panel or whip antenna, power density $S = \frac{180}{\theta_{BW}} \times \frac{0.1 \times P_{net}}{\pi \times D \times h}$, in mW/cm²,

and for an aperture antenna, maximum power density $S_{max} = \frac{0.1 \times 16 \times \eta \times P_{net}}{\pi \times h^2}$, in mW/cm²,

where θ_{BW} = half-power beamwidth of the antenna, in degrees, and

P_{net} = net power input to the antenna, in watts,

D = distance from antenna, in meters,

h = aperture height of the antenna, in meters, and

η = aperture efficiency (unitless, typically 0.5-0.8).

The factor of 0.1 in the numerators converts to the desired units of power density.

Far Field.

OET-65 gives this formula for calculating power density in the far field of an individual RF source:

power density $S = \frac{2.56 \times 1.64 \times 100 \times RFF^2 \times ERP}{4 \times \pi \times D^2}$, in mW/cm²,

where ERP = total ERP (all polarizations), in kilowatts,

RFF = relative field factor at the direction to the actual point of calculation, and

D = distance from the center of radiation to the point of calculation, in meters.

The factor of 2.56 accounts for the increase in power density due to ground reflection, assuming a reflection coefficient of 1.6 (1.6 x 1.6 = 2.56). The factor of 1.64 is the gain of a half-wave dipole relative to an isotropic radiator. The factor of 100 in the numerator converts to the desired units of power density. This formula has been built into a proprietary program that calculates, at each location on an arbitrary rectangular grid, the total expected power density from any number of individual radiation sources. The program also allows for the description of uneven terrain in the vicinity, to obtain more accurate projections.



ATTACHMENT G

December 29, 2016

City Planner
Planning Department
City of Oakland
250 Frank H. Ogawa Plaza, 2nd Floor
Oakland, CA 94612

Re: GO 95 Required Two Feet Clearance Between Antenna and Pole
Applicant: ExteNet Systems (California) LLC
Nearest Site Address: Public Right of Way near 1301 90th Avenue
Site ID: NW-CA-SANFRNMC-TMO Node 06103A
Latitude/Longitude: 37.7491730, -122.1764010
Planning Application: PLN16399

Dear City Planner,

This letter is in response to discussions with City of Oakland Planning Department seeking clarification on the proposed antenna placement on the utility pole.

Wireless facility attachments to utility poles must comply with CPUC General Order 95 design, safety and clearance standards. Specifically, Rule 94.4(E) states: *Antennas shall maintain a 2 ft horizontal clearance from centerline of pole when affixed between supply and communication lines or below communication lines.* This rule precludes ExteNet from placing the antennas flush mounted to the utility pole when there is a power source attached to the pole. ExteNet minimized the clearance as much as possible by placing the antenna shroud just over two feet from the centerline of the utility pole.

Feel free to contact me if you have any questions. Thank you.

Thank you.

Best Regards,

Ana Gomez
ExteNet Permitting Contractor



CITY OF OAKLAND
BUREAU OF PLANNING
 250 Frank H. Ogawa Plaza, Suite 2114, Oakland, CA 94612-2031
 Phone: 510-238-3911 Fax: 510-238-4730

PLANNING COMMISSION PUBLIC NOTICE

Location:	The Public Right-of-Way Adjacent to 1301 90 th Ave.
Assessor's Parcel Number(s):	Nearest adjacent lot (042 427001500)
Proposal:	To establish a telecommunications facility, to enhance existing services, by attaching an antenna and equipment to an existing wooden utility pole located in the public right-of-way (sidewalk). The 37' wooden utility pole is existing.
Applicant:	Extenet Systems (California) LLC. (for T-Mobile USA, INC)
Contact Person/ Phone Number:	Ana Gomez (913) 458-9148
Owner:	Joint Pole Authority (JPA) including PG&E
Case File Number:	PLN16399
Planning Permits Required:	Major Design Review to install a wireless Telecommunication Macro Facility on a PG&E replacement pole located in RD-1 Zone.
General Plan:	Detached Unit Residential
Zoning:	RD-1 Detached Unit Residential Zone.
Environmental Determination:	Exempt, Section 15303 of the State CEQA Guidelines; New construction or conversion of small structures. Exempt, Section 15183 of the State CEQA Guidelines; Projects consistent with a Community Plan, General Plan or Zoning.
Historic Status:	Not a Potential Designated Historic Property; Survey rating: n/a
City Council District:	7
Finality of Decision:	Appealable to City Council within 10 Days
For Further Information:	Contact case planner Danny Thai at (510) 238-3584 or by email at dthai@oaklandnet.com .

... questions, if any, should be directed to the Bureau of Planning, 250 Frank H. Ogawa Plaza, 2nd Floor, Oakland, California 94612-2031 at or prior to the ... held on **February 1, 2017**, at Oakland City Hall, Council Chambers, 1 Frank H. Ogawa Plaza, Oakland, California 94612. The public hearing will start at

... Planning Commission decision on appeal and/or in court, you will be limited to issues raised at the public hearing or in correspondence delivered to the Bureau ... prior to, the public hearing on this case. If you wish to be notified of the decision of any of these cases, please provide the case planner with a regular mail or

... description of the application found above is preliminary in nature and that the project and/or such description may change prior to a decision being made. ... nce a decision is reached by the Planning Commission on these cases, they are appealable to the City Council. Su ... **date of decision by the Planning Commission and by 4:00p.m.** An appeal shall be on a form provided by the B ... Ogawa Plaza, Suite 2114, to the attention of the Case Planner. The appeal shall state specifically wherein it is claim ... or wherein the decision is not supported by substantial evidence and must include payment in accordance with the ... appeal will preclude you from challenging the City's decision in court. The appeal itself must raise every issue that ... previously entered into the record prior to or at the public hearing mentioned above. Failure to do so will preclud ... court.

... DATE: January 13, 2017

ATTACHMENT H





NO STOPPING ANY VEHICLES

15 MPH

NOTICE OF OBLIGATION

7S.W. 9003