

Case File Number: PLN16-386

April 5, 2017

Location:	The Public Right-of-Way Adjacent to 2701 Foothill Blvd Blvd. (See map on reverse)
Assessor Parcel Numbers:	Nearest adjacent lot (025 073300101)
Proposal:	To establish a new "small cell site" telecommunications facility, in order to enhance existing services, by attaching an antenna and equipment to a wooden utility pole located in the sidewalk.
Applicant:	Extenet Systems (California) LLC. (for T-Mobile USA, INC)
Contact Person/ Phone Number:	Ana Gomez (913) 458-9148
Owner:	Joint Pole Authority (JPA) including PG&E
Case File Number:	PLN16-386
Planning Permits Required:	Major Design Review to install a wireless Telecommunication Macro Facility on a PG&E replacement pole located in RU-5 Zone.
General Plan:	Urban Residential
Zoning:	RU-5 Urban Residential Zone.
Environmental Determination:	Exempt, Section 15303 of the State CEQA Guidelines; New construction or conversion of small structures. Exempt, Section 15183 of the State CEQA Guidelines; Projects consistent with a Community Plan, General Plan or Zoning.
Historic Status:	Not a Potential Designated Historic Property; Survey rating: n/a
City Council District:	5
Finality of Decision:	Appealable to City Council within 10 Days
For Further Information:	Contact case Planner Danny Thai at (510) 238-3584 or dthai@oaklandnet.com

SUMMARY

The project applicant (Extenet Systems) is proposing to install a wireless telecommunication facility on a PG&E utility pole located in the public right-of-way near 2701 Foothill Blvd. The project involves installation of one canister antenna on an existing 56' tall wood utility pole. The installation of one canister antenna would measure 23.5" long and 7.9" in diameter at the height of 18' and two radio units (7.9" tall, 7.9" wide and 3.9" depth) mounted at the height of 10'-6" and 13'-11" above ground . The proposed antenna and associated related equipment are compatible with the PG&E utility pole. The proposed antenna would be extended toward the street and painted matte silver to match the surroundings. As a result, the proposed telecommunications facility is an appropriate location and would not significantly increase negative visual impacts to adjacent neighboring residential properties. The project meets all the required findings for approval of the project. Staff recommends approval, subject to the conditions described in this report.

BACKGROUND

For several years in the City of Oakland, telecommunications carriers have proposed facility installation within the public right-of-way, instead of private property. These facilities typically consist of antennas and associated equipment attached to utility poles or street light poles. Poles are often replaced with replicas for technical purposes. The main purpose is to enhance existing service, given increasing technological demands for bandwidth, through new technology and locational advantages. The City exercises zoning jurisdiction over such projects in response to a 2009 State Supreme Court case decision (*Sprint v. Palos Verdes Estates*). Under the Planning Code, utility or joint pole authority (JPA) sites are classified by staff as “Macro Facilities,” and street light pole sites (lamps, not traffic signals) as “Monopole Facilities.” For JPA poles, only Design Review approval may be required, as opposed to Design Review and a Conditional Use Permit, for example. For non-JPA pole sites, such as City light poles, projects also require review by the City’s Public Works Agency (PWA) and Real Estate Division and involve other considerations such as impacts to historical poles. The PWA may also review projects involving street lights. In either case, the practice has been to refer all such projects to the Planning Commission for decision when located in or near a residential zone.

Several projects for new DAS (distributed antenna services) facilities have come before the Planning Commission for a decision and have been installed throughout the Oakland Hills. Some applications have been denied due to view obstructions or propinquity to residences. Improved practices for the processing of all types of sites incorporating Planning Commission direction have been developed as a result. Conditions of approval typically attach requirements such as painting and texturing of approved components to more closely match utility poles in appearance. Approvals do not apply to any replacement project should the poles be removed for any reason. As with sites located on private property, the Federal Government precludes cities from denying an application on the basis of emissions concerns if a satisfactory emissions report is submitted. More recent Federal changes have streamlined the process to service existing facilities.

Currently, telecommunications carriers are in the process of attempting to deploy “small cell sites.” These projects also involve attachment of antennas and equipment at public right-of-way facilities such as poles or lights for further enhancement of services. However, components are now somewhat smaller in size than in the past. Also, sites tend to be located in flatland neighborhoods and Downtown where view obstructions are less likely to be an issue. Good design and placement are given full consideration nonetheless, especially with the greater presence of historic structures in Downtown. Additionally, given the sheer multitude of applications, and, out of consideration for Federal requirements for permit processing timelines, staff may develop alternatives to traditional staffing and agendas.

Limitations on Local Government Zoning Authority under the Telecommunications Act of 1996

Section 704 of the Telecommunications Act of 1996 (TCA) provides federal standards for the siting of “Personal Wireless Services Facilities.” “Personal Wireless Services” include all commercial mobile services (including personal communications services (PCS), cellular radio mobile services, and paging); unlicensed wireless services; and common carrier wireless exchange access services. Under Section 704, local zoning authority over personal wireless

services is preserved such that the FCC is prevented from preempting local land use decisions; however, local government zoning decisions are still restricted by several provisions of federal law. Specifically:

- Under Section 253 of the TCA, no state or local regulation or other legal requirement can prohibit or have the effect of prohibiting the ability of any entity to provide any interstate or intrastate telecommunications service.
- Further, Section 704 of the TCA imposes limitations on what local and state governments can do. Section 704 prohibits any state and local government action which unreasonably discriminates among personal wireless providers. Local governments must ensure that its wireless ordinance does not contain requirements in the form of regulatory terms or fees which may have the “effect” of prohibiting the placement, construction, or modification of personal wireless services.
- Section 704 also preempts any local zoning regulation purporting to regulate the placement, construction and modification of personal wireless service facilities on the basis, either directly or indirectly, on the environmental effects of radio frequency emissions (RF) of such facilities, which otherwise comply with Federal Communications Commission (FCC) standards in this regard (See 47 U.S.C. Section 332(c)(7)(B)(iv)(1996)). This means that local authorities may not regulate the siting or construction of personal wireless facilities based on RF standards that are more stringent than those promulgated by the FCC.
- Section 704 mandates that local governments act upon personal wireless service facility siting applications to place, construct, or modify a facility within a reasonable time (See 47 U.S.C.332(c)(7)(B)(ii) and the FCC Shot Clock ruling setting forth “reasonable time” standards for applications deemed complete).
- Section 704 also mandates that the FCC provide technical support to local governments in order to encourage them to make property, rights-of-way, and easements under their jurisdiction available for the placement of new spectrum-based telecommunications services. This proceeding is currently at the comment stage.

For more information on the FCC’s jurisdiction in this area, consult the following:

Competition & Infrastructure Policy Division (CIPD) of the Wireless Telecommunications Bureau, main division number: (202) 418-1310.

Main division website: <https://www.fcc.gov/general/competition-infrastructure-policy-division-wireless-telecommunications-bureau>

Tower siting: <https://www.fcc.gov/general/tower-and-antenna-siting>

SITE DESCRIPTION

The existing 56' tall PG&E utility pole is located in the City of Oakland public right-of-way and is 78'-0" away from an adjacent one-story commercial building located at 2701 Foothill Blvd.

PROJECT DESCRIPTION

The applicant proposes to install a wireless telecommunication facility on a PG&E utility pole located in the public right-of-way near 2701 Foothill Blvd. The project involves installation of one canister antenna on an existing 56' tall wood utility pole. The installation of one canister antenna would measure 23.5" long and 7.9" in diameter at the height of 18' and two radio units (7.9" tall, 7.9" wide and 3.9" depth) mounted at the height of 10'-6" and 13'-11" above ground (See Attachment C).

GENERAL PLAN ANALYSIS

The site is classified as Urban Residential per the Oakland General Plan's Land Use and Transportation Element (LUTE). This classification is intended to create, maintain, and enhance areas of the City that are appropriate for multi-unit, mid-rise or high-rise residential structures in locations with good access to transportation and other services. According to the LUTE, "The primary future use in this classification is residential. Mixed use buildings that house ground floor commercial uses and public facilities of compatible character are also encouraged."

The proposed unmanned wireless telecommunication facility will not adversely affect and detract from the characteristics of the neighborhood. The proposed new pole is similar to other utility poles within the same block. The proposed antenna and associated related equipment are compatible with the typical utilities located on these poles. As a result, the proposal is an appropriate location for the proposed telecommunication facility and would not significantly increase negative visual impacts to adjacent neighboring residential properties

ZONING ANALYSIS

The proposed telecommunications facility is located within the RU-5 Urban Residential Zone. The intent of the RU-5 Zone is to create, maintain and enhance areas of the City that are appropriate for multi-unit, mid-rise, and high rise residential structures and ground floor neighborhood businesses on the City's major corridors.

Section 17.136.040 and 17.128.070 of the City of Oakland Planning Code requires a Major Design Review permit for Macro Telecommunication facilities that are attached to utility poles in the RU-5 Zone or that are located within one hundred (100) feet of the boundary of any residential zone. Special findings are also required for Design Review approval to ensure that the facility is concealed to the greatest extent possible. The project design is discussed later in the *Key Issues and Impacts* section of this report, and the required findings for Major Design Review are listed and included in staff's evaluation later in the *Findings* section of this report.

ENVIRONMENTAL DETERMINATION

The California Environmental Quality Act (CEQA) Guidelines list the projects that qualify as categorical exemptions from environmental review. The proposed project is categorically exempt from the environmental review requirements pursuant to Section 15303 for installation of

telecommunication facility (small structure) on a new proposed public utility pole. Furthermore, the project is also exempt per Section 15183, for projects consistent with a community plan, general plan or zoning.

KEY ISSUES AND IMPACTS

Project Site

Section 17.128.070A of the City of Oakland Telecommunications Regulations requires that new macro telecommunications facilities shall generally be designed according to the following development guidelines, followed by staff's analysis in relation to this application:

- A. The Macro Facilities shall be located on existing buildings, poles or other existing support structures, or shall be post mounted.
- B. The equipment shelter or cabinet must be concealed from public view or made compatible with the architecture of the surrounding structures or placed underground. The shelter or cabinet must be regularly maintained.
- C. Macro Facilities may exceed the height limitation specified for all zones but may not exceed fifteen (15) feet above the roof line or parapet. Placement of an antenna on a nonconforming structure shall not be considered to be an expansion of the nonconforming structure.
- D. Ground post mounted Macro Facilities must not exceed seventeen (17) feet to the top of the antenna.
- E. The applicant shall submit written documentation demonstrating that the emissions from the proposed project are within the limits set by the Federal Communications Commission.

The facility involves attachment an existing utility pole hosting power lines and a City street light. Recommended conditions of approval require painting and texturing the antenna matte silver and all components matte brown to match the appearance of the wooden utility pole and power line posts. The proposal does not involve attachment to a roofed structure, exceed fifteen (15) feet above the roof line of the adjacent property, or involve a ground post mounted facility. A satisfactory emissions report has been submitted and is attached to this report (See Attachment F).

Project Site

Section 17.128.110 of Oakland's Telecommunication Regulations requires that new wireless facilities shall generally be located on designated properties or facilities in the following order of ranked preference:

- A. Co-located on an existing structure or facility with existing wireless antennas.
- B. City owned properties or other public or quasi-public facilities.
- C. Existing commercial or industrial structures in non-residential zones (excluding all HBX Zones and the D-CE3 and D-C-4 Zones).
- D. Existing commercial or industrial structures in residential zones, HBX Zones, or the D-CE-3 or D-CE-4 Zones.
- E. Other non-residential uses in residential zones, HBX Zones, or the D-CE-3 or D-CE-4 Zones.

- F. Residential uses in non-residential zones. (excluding all HBX Zones and the D-CE-3 and D-CE-4 Zones).
- G. Residential uses in residential zones, HBX Zones, or the D-CE-3 or D-CE-4 Zones.

Facilities sited on an A, B or C ranked preferences do not require a site alternatives analysis. Facilities proposing to locate on a D through G ranked preference, inclusive, must submit a site alternatives analysis as part of the required application materials. Since the proposed project involves an attachment to an existing wood utility pole within the public right-of-way and installation of a new antenna and radio units within RU-5 Zone, the proposed project meets B preferences and hence a site alternatives analysis is not required. However, the applicant has submitted an analysis which is attached (See Attachment E).

Extenet System considered alternative sites on other utility poles in this area, but none of these are as desirable from a service coverage or aesthetics perspective (See Attachment E). The proposed location is approximately equidistant from other Distributed Antenna System (DAS) nodes proposed in the surrounding area so that service coverage can be evenly distributed. The staff has reviewed the applicant's alternative sites analysis (See Attachment E) and determined that the site selected conforms to the telecommunication regulation requirements. Furthermore, staff agrees that the proposed site is the most preferable location for the new telecommunications facility.

Project Design

Section 17.128.120 of the City of Oakland Telecommunications Regulations requires that new wireless facilities shall generally be designed in the following order of ranked preference:

- A. Building or structure mounted antennas completely concealed from view.
- B. Building or structure mounted antennas set back from roof edge, not visible from public right-of-way.
- C. Building or structure mounted antennas below roof line (facade mount, pole mount) visible from public right-of-way, painted to match existing structure.
- D. Building or structure mounted antennas above roof line visible from public right-of-way.
- E. Monopoles.
- F. Towers.

Facilities designed to meet an A and B ranked preference do not require a site design alternatives analysis. Facilities designed to meet C through F ranked preference, inclusive, must submit a site design alternatives analysis as part of the required application materials. A site design alternatives analysis shall, at a minimum, consist of:

Written evidence must indicate why each higher preference design alternative cannot be used. Such evidence shall be in sufficient detail that independent verification could be obtained if required by the City of Oakland Zoning Manager. Evidence should indicate if the reason an alternative was rejected was technical (e.g. incorrect height, interference from existing RF sources, inability to cover required area) or for other concerns (e.g. inability to provide utilities, construction or structural impediments).

Since the proposed project does not meet preference A and B, a site design alternatives analysis is required. The proposal most closely conforms to 'C' (structured mounted antennas below roof line), and the applicant has submitted a satisfactory site design alternatives analysis (See Attachment E).

Extenet System evaluated whether the equipment could be undergrounded but unfortunately this is not possible because there is insufficient right-of-way space for the necessary equipment access and the equipment would be compromised by rainwater saturation. The proposed antenna design is approximately equidistant from other DAS nodes proposed in the surrounding area so that service coverage can be evenly distributed. The proposed design is a good option because the facility is located where a signal can be adequately propagated without obstruction, which could not have been the case if the antenna was located on a building or concealed. The proposed screened antenna will be painted matte silver and associated equipment will be concealed to the extent possible by painting to match the wooden utility pole. The proposal would not significantly increase negative visual impacts to adjacent neighboring residential properties.

Project Radio Frequency Emissions Standards

Section 17.128.130 of the City of Oakland Telecommunication Regulations requires that the applicant submits the following verifications including requests for modifications to existing facilities:

a. The Telecommunications regulations require that the applicant submit written documentation demonstrating that the emission from the proposed project are within the limits set by the Federal Communications Commission. In the document (attachment B) prepared by Hammett & Edison Consulting Engineers Inc. the proposed project was evaluated for compliance with appropriate guidelines limiting human exposure to radio frequency electromagnetic fields. According to the report on the proposal, the project will comply with the prevailing standards for limiting public exposure to radio frequency energy and, therefore, the proposed site will operate within the current acceptable thresholds as established by the Federal Government or any such agency that may be subsequently authorized to establish such standards.

b. Prior to final building permit sign off, an RF emissions report indicating that the site is actually operating within the acceptable thresholds as established by the Federal government or any such agency who may be subsequently authorized to establish such standards.

The RF emissions report, prepared by Hammett & Edison Consulting Engineers Inc was submitted with the initial application (See Attachment F). The report states that the proposed project will comply with the prevailing standards for limiting public exposure to radio frequency energy, and therefore, will not cause a significant impact on the environment. Furthermore, staff recommends that before the final building permit sign off, the applicant submits a certified RF emissions report stating that the facility is operating within acceptable thresholds established by the federal regulatory agency.

CONCLUSION

The proposed project meets all of the required findings for Design Review approval. The proposal will provide essential telecommunication services to the community and the City of Oakland at large. It will also be available to emergency services such as police, fire department and emergency response teams. Staff requested that the applicant provides a “slimmer” design consisting of tucking the antenna in closer to the pole. The applicant responded that this was not feasible due to the technological requirements by the Public Utilities Commission (See Attachment G). Staff, therefore, finds the proposal to provide an essential service with a least-intrusive possible design. Draft conditions of approval stipulate that the components be painted and textured to match the wooden utility pole in appearance for camouflaging.

RECOMMENDATIONS:

1. Affirm staff’s environmental determination
2. Approve Major Design Review application, subject to the attached findings and conditions of approval.

Prepared by:

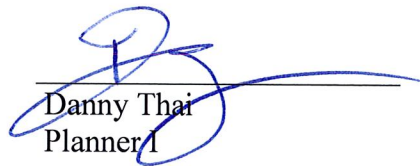

Danny Thai
Planner I

Reviewed by:



Scott Miller
Zoning Manager

Approved for forwarding to the
City Planning Commission



Darin Ranelletti, Interim Director
Bureau of Planning and Building

ATTACHMENTS:

- A. Findings
- B. Conditions of Approval
- C. Plans dated September 27, 2016
- D. Applicant's Photo-Simulations
- E. Site Alternatives Analysis/Site Design Alternatives Analysis dated September 27, 2016
- F. RF Emissions Report by Hammett & Edison, Inc. dated October 25, 2016
- G. CPUC Compliance Letter dated February 17, 2017
- H. Applicant-proof of public notification posting

FINDINGS FOR APPROVAL

This proposal meets the required findings under Section 17.136.050 (B) (Non-Residential Design Review criteria); and, 17.128.060(B) (Telecommunications Macro Facilities 17.128.070 (B), as set forth below. Required findings are shown in **bold** type; reasons proposal satisfies them are shown in normal type.

17.136.050(B) – NONRESIDENTIAL DESIGN REVIEW CRITERIA:

1. That the proposal will help achieve or maintain a group of facilities which are well related to one another and which, when taken together, will result in a well-composed design, with consideration given to site, landscape, bulk, height, arrangement, texture, materials, colors, and appurtenances; the relation of these factors to other facilities in the vicinity; and the relation of the proposal to the total setting as seen from key points in the surrounding area. Only elements of design which have some significant relationship to outside appearance shall be considered, except as otherwise provided in Section 17.136.060;

The project involves the installation of a new wireless Telecommunication facility on an existing 56' tall wood PG&E utility pole located in the public right-of-way. The attachment of a small antenna and equipment to a non-historic utility pole, painted and texturized to match the wooden pole and power line posts in appearance for camouflaging will be the least intrusive design.

2. That the proposed design will be of a quality and character which harmonizes with, and serves to protect the value of, private and public investments in the area;

The pole will be similar to other wood PG&E poles. The proposed antennas and radio units will be typical of the utility equipment found on poles: located high up on the pole, oriented toward the street and painted to match with the new replaced PG&E utility pole. Therefore, the facility will not adversely affect and detract from residential characteristics of the neighborhood.

3. That the proposed design conforms in all significant respects with the Oakland General Plan and with any applicable design review guidelines or criteria, district plan, or development control map which have been adopted by the Planning Commission or City Council.

The site is classified as Urban Residential per the Oakland General Plan's Land Use and Transportation Element (LUTE). This classification is intended to create, maintain, and enhance areas of the City that are appropriate for multi-unit, mid-rise or high-rise residential structures in locations with good access to transportation and other services. According to the LUTE, "The primary future use in this classification is residential. Mixed use buildings that house ground floor commercial uses and public facilities of compatible character are also encouraged."

Section 17.128.120 of the City of Oakland Telecommunications Regulations describes the design criteria for wireless facilities. In general, these facilities should either be concealed from view or not visible from the public right of way. Since the project did not meet either ranked criteria, but did meet criteria D as also described in 17.128.120, an alternative site design study needed to be undertaken. The analysis shows that the proposed new pole is similar to other utility poles within the same block. The proposed antenna and associated related equipment are compatible with and

typical of the utility equipment on these poles, the proposed antenna will be extended toward the street and away from the commercial facility at 2701 Foothill Blvd, and painted to match the surroundings. As result, the proposal is consistent telecommunication regulation requirements, in an appropriate location, and of an appropriate design that would not significantly increase negative visual impacts to adjacent neighboring residential properties

17.128.070(B) DESIGN REVIEW CRITERIA FOR MACRO FACILITIES

1. Antennas should be painted and/or textured to match the existing structure:

The antenna will be painted and texturized matte silver to match the power line posts in appearance for camouflaging to reduce visual impact as required by conditions of approval.

2. Antennas mounted on architecturally significant structures or significant architectural details of the building should be covered by appropriate casings which are manufactured to match existing architectural features found on the building:

The proposed antenna and equipment will not be mounted onto an architecturally significant structure but a proposed new wooden utility pole.

3. Where feasible, antennas can be placed directly above, below or incorporated with vertical design elements of a building to help in camouflaging:

The proposal antennas will be placed above and vertically in line with, the proposed utility pole and painted matte silver to blend with the surroundings.

4. Equipment shelters or cabinets shall be screened from the public view by using landscaping, or materials and colors consistent with surrounding backdrop:

The associated equipment cabinets will be located within a shroud attached to a replaced utility pole and painted to match the proposed wooden pole to minimize visual impacts on the neighboring properties.

5. Equipment shelters or cabinets shall be consistent with the general character of the area.

See above finding # 4

6. For antennas attached to the roof, maintain a 1:1 ratio for equipment setback; screen the antennas to match existing air conditioning units, stairs, or elevator towers; avoid placing roof mounted antennas in direct line with significant view corridors.

N/A

7. That all reasonable means of reducing public access to the antennas and equipment has been made, including, but not limited to, placement in or on buildings or structures, fencing, anti-climbing measures and anti-tampering devices.

The proposed screened antenna will be mounted at the height of 18' on a existing PG&E utility pole and will not be accessible to the public due to its location. The radio units' equipment will be attached to the pole 10'-6" and 13'-11" above the ground. The lowest height of the facility's equipment is 7'-4" above the ground.

ATTACHMENT B

CONDITIONS OF APPROVAL

PLN16-386

STANDARD CONDITIONS:

1. Approved Use

The project shall be constructed and operated in accordance with the authorized use as described in the approved application materials, **PLN16-386** and submitted plans **dated** September 27, 2016, as amended by the following conditions of approval and mitigation measures, if applicable (“Conditions of Approval” or “Conditions”).

2. Effective Date, Expiration, Extensions and Extinguishment

This Approval shall become effective immediately, unless the Approval is appealable, in which case the Approval shall become effective in ten calendar days unless an appeal is filed. Unless a different termination date is prescribed, this Approval shall expire **two calendar years** from the Approval date, or from the date of the final decision in the event of an appeal, unless within such period all necessary permits for construction or alteration have been issued, or the authorized activities have commenced in the case of a permit not involving construction or alteration. Upon written request and payment of appropriate fees submitted no later than the expiration date of this Approval, the Director of City Planning or designee may grant a one-year extension of this date, with additional extensions subject to approval by the approving body. Expiration of any necessary building permit or other construction-related permit for this project may invalidate this Approval if said Approval has also expired. If litigation is filed challenging this Approval, or its implementation, then the time period stated above for obtaining necessary permits for construction or alteration and/or commencement of authorized activities is automatically extended for the duration of the litigation.

3. Compliance with Other Requirements

The project applicant shall comply with all other applicable federal, state, regional, and local laws/codes, requirements, regulations, and guidelines, including but not limited to those imposed by the City’s Bureau of Building, Fire Marshal, and Public Works Department. Compliance with other applicable requirements may require changes to the approved use and/or plans. These changes shall be processed in accordance with the procedures contained in Condition #4.

4. Minor and Major Changes

- a. Minor changes to the approved project, plans, Conditions, facilities, or use may be approved administratively by the Director of City Planning.
- b. Major changes to the approved project, plans, Conditions, facilities, or use shall be reviewed by the Director of City Planning to determine whether such changes require

submittal and approval of a revision to the Approval by the original approving body or a new independent permit/approval. Major revisions shall be reviewed in accordance with the procedures required for the original permit/approval. A new independent permit/approval shall be reviewed in accordance with the procedures required for the new permit/approval.

5. Compliance with Conditions of Approval

- a. The project applicant and property owner, including successors, (collectively referred to hereafter as the “project applicant” or “applicant”) shall be responsible for compliance with all the Conditions of Approval and any recommendations contained in any submitted and approved technical report at his/her sole cost and expense, subject to review and approval by the City of Oakland.
- b. The City of Oakland reserves the right at any time during construction to require certification by a licensed professional at the project applicant’s expense that the as-built project conforms to all applicable requirements, including but not limited to, approved maximum heights and minimum setbacks. Failure to construct the project in accordance with the Approval may result in remedial reconstruction, permit revocation, permit modification, stop work, permit suspension, or other corrective action.
- c. Violation of any term, Condition, or project description relating to the Approval is unlawful, prohibited, and a violation of the Oakland Municipal Code. The City of Oakland reserves the right to initiate civil and/or criminal enforcement and/or abatement proceedings, or after notice and public hearing, to revoke the Approval or alter these Conditions if it is found that there is violation of any of the Conditions or the provisions of the Planning Code or Municipal Code, or the project operates as or causes a public nuisance. This provision is not intended to, nor does it, limit in any manner whatsoever the ability of the City to take appropriate enforcement actions. The project applicant shall be responsible for paying fees in accordance with the City’s Master Fee Schedule for inspections conducted by the City or a City-designated third-party to investigate alleged violations of the Approval or Conditions.

6. Signed Copy of the Approval/Conditions

A copy of the Approval letter and Conditions shall be signed by the project applicant, attached to each set of permit plans submitted to the appropriate City agency for the project, and made available for review at the project job site at all times.

7. Blight/Nuisances

The project site shall be kept in a blight/nuisance-free condition. Any existing blight or nuisance shall be abated within 60 days of approval, unless an earlier date is specified elsewhere.

8. Indemnification

- a. To the maximum extent permitted by law, the project applicant shall defend (with counsel acceptable to the City), indemnify, and hold harmless the City of Oakland, the Oakland City Council, the Oakland Redevelopment Successor Agency, the Oakland

City Planning Commission, and their respective agents, officers, employees, and volunteers (hereafter collectively called “City”) from any liability, damages, claim, judgment, loss (direct or indirect), action, causes of action, or proceeding (including legal costs, attorneys’ fees, expert witness or consultant fees, City Attorney or staff time, expenses or costs) (collectively called “Action”) against the City to attack, set aside, void or annul this Approval or implementation of this Approval. The City may elect, in its sole discretion, to participate in the defense of said Action and the project applicant shall reimburse the City for its reasonable legal costs and attorneys’ fees.

- b. Within ten (10) calendar days of the filing of any Action as specified in subsection (a) above, the project applicant shall execute a Joint Defense Letter of Agreement with the City, acceptable to the Office of the City Attorney, which memorializes the above obligations. These obligations and the Joint Defense Letter of Agreement shall survive termination, extinguishment, or invalidation of the Approval. Failure to timely execute the Letter of Agreement does not relieve the project applicant of any of the obligations contained in this Condition or other requirements or Conditions of Approval that may be imposed by the City.

9. Severability

The Approval would not have been granted but for the applicability and validity of each and every one of the specified Conditions, and if one or more of such Conditions is found to be invalid by a court of competent jurisdiction this Approval would not have been granted without requiring other valid Conditions consistent with achieving the same purpose and intent of such Approval.

10. Job Site Plans

A copy of the Approval letter and Conditions shall be signed by the project applicant, attached to each set of permit plans submitted to the appropriate City agency for the project, and made available for review at the project job site at all times.

11. Special Inspector/Inspections, Independent Technical Review, Project Coordination and Monitoring

The project applicant may be required to cover the full costs of independent third-party technical review and City monitoring and inspection, including without limitation, special inspector(s)/inspection(s) during times of extensive or specialized plan-check review or construction, and inspections of potential violations of the Conditions of Approval. The project applicant shall establish a deposit with the Bureau of Building, if directed by the Building Official, Director of City Planning, or designee, prior to the issuance of a construction-related permit and on an ongoing as-needed basis.

12. Public Improvements

The project applicant shall obtain all necessary permits/approvals, such as encroachment permits, obstruction permits, curb/gutter/sidewalk permits, and public improvement (“p-job”) permits from the City for work in the public right-of-way, including but not limited

to, streets, curbs, gutters, sidewalks, utilities, and fire hydrants. Prior to any work in the public right-of-way, the applicant shall submit plans for review and approval by the Bureau of Planning, the Bureau of Building, and other City departments as required. Public improvements shall be designed and installed to the satisfaction of the City.

13. Construction Days/Hours

Requirement: The project applicant shall comply with the following restrictions concerning construction days and hours:

- a. Construction activities are limited to between 7:00 a.m. and 7:00 p.m. Monday through Friday, except that pier drilling and/or other extreme noise generating activities greater than 90 dBA shall be limited to between 8:00 a.m. and 4:00 p.m.
- b. Construction activities are limited to between 9:00 a.m. and 5:00 p.m. on Saturday. In residential zones and within 300 feet of a residential zone, construction activities are allowed from 9:00 a.m. to 5:00 p.m. only within the interior of the building with the doors and windows closed. No pier drilling or other extreme noise generating activities greater than 90 dBA are allowed on Saturday.
- c. No construction is allowed on Sunday or federal holidays.

Construction activities include, but are not limited to, truck idling, moving equipment (including trucks, elevators, etc.) or materials, deliveries, and construction meetings held on-site in a non-enclosed area.

Any construction activity proposed outside of the above days and hours for special activities (such as concrete pouring which may require more continuous amounts of time) shall be evaluated on a case-by-case basis by the City, with criteria including the urgency/emergency nature of the work, the proximity of residential or other sensitive uses, and a consideration of nearby residents'/occupants' preferences. The project applicant shall notify property owners and occupants located within 300 feet at least 14 calendar days prior to construction activity proposed outside of the above days/hours. When submitting a request to the City to allow construction activity outside of the above days/hours, the project applicant shall submit information concerning the type and duration of proposed construction activity and the draft public notice for City review and approval prior to distribution of the public notice.

When Required: During construction

Initial Approval: N/A

Monitoring/Inspection: Bureau of Building

PROJECT-SPECIFIC CONDITIONS

14. Emissions Report

Requirement: A RF emissions report shall be submitted to the Planning Bureau indicating that the site is actually operating within the acceptable thresholds as established by the Federal government or any such agency who may be subsequently authorized to establish such standards.

Requirement: Prior to a final inspection

When Required: Prior to final building permit signoff

Initial Approval: N/A

Monitoring/Inspection: N/A

15. Camouflage

Requirement: The antenna shall be painted, texturized, and maintained matte silver, and the equipment and any other accessory items including cables matte brown, to better camouflage the facility to the utility pole and attached power line posts.

When Required: Prior to a final inspection

Initial Approval: N/A

Monitoring/Inspection: Bureau of Building

16. Operational

Requirement: Noise levels from the activity, property, or any mechanical equipment on site shall comply with the performance standards of Section 17.120 of the Oakland Planning Code and Section 8.18 of the Oakland Municipal Code. If noise levels exceed these standards, the activity causing the noise shall be abated until appropriate noise reduction measures have been installed and compliance verified by the Planning and Zoning Division and Building Services.

When Required: Ongoing

Initial Approval: N/A

Monitoring/Inspection: Bureau of Building

17. Possible District Undergrounding PG&E Pole

Requirement: Should the PG &E utility pole be permanently removed for purposes of district undergrounding or otherwise, the telecommunications facility can only be re-established by applying for and receiving approval of a new application to the Oakland Planning Bureau as required by the regulations.

When Required: Ongoing

Initial Approval: N/A

Monitoring/Inspection: N/A

NW-CA-SANFRNMC 06044A

ADJACENT TO (IN PROW)
2630 FOOTHILL BOULEVARD
OAKLAND, CA 94601

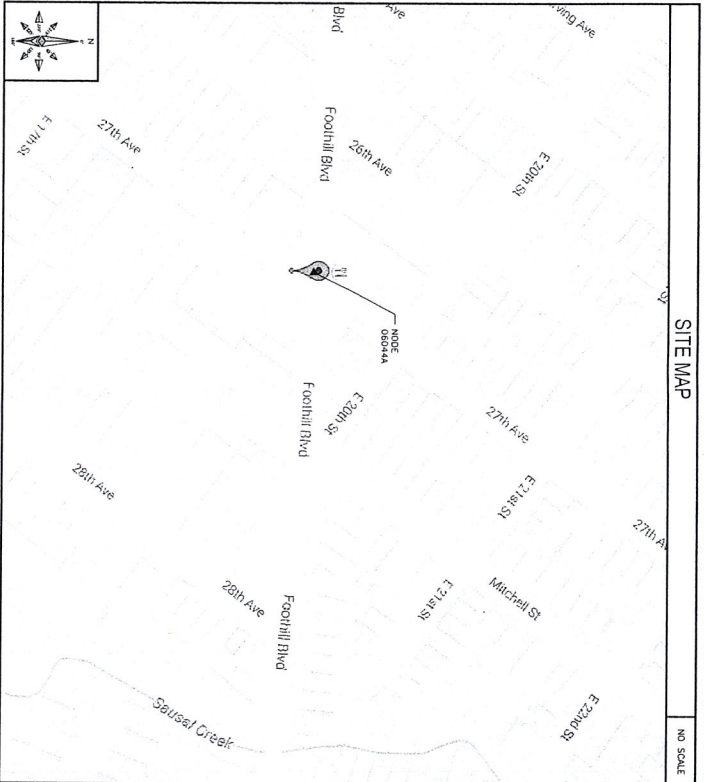
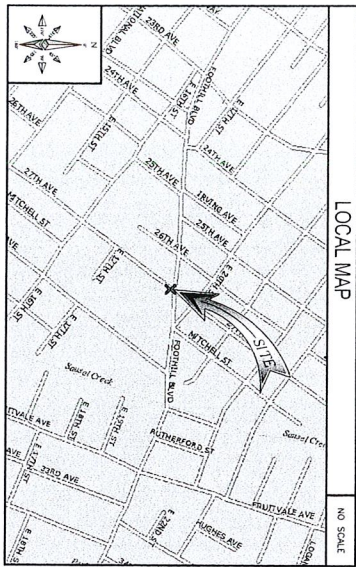

SHEET INDEX	
SHEET NO:	SHEET TITLE
1-1	TITLE SHEET
00-1	GENERAL NOTES AND LEGEND
C-1	OVERALL SITE PLAN
C-2	UTILITY POLE ELEVATIONS AND RISER DETAILS
C-3	EQUIPMENT DETAILS
C-4	EQUIPMENT DETAILS

PROJECT INFORMATION	
POLE OWNER	OWNER: EXTENET SYSTEMS CA, LLC
APPLICANT	COMPANY: EXTENET SYSTEMS (CALIFORNIA), LLC CONTACT: MATTHEW VERONICH ADDRESS: 2000 CROW CANYON PLACE, SUITE 210 SAN RAMON, CA 94583 PHONE: (415) 596-3474 E-MAIL: MVERONICH@EXTENETSYSTEMS.COM
AGENT	COMPANY: BLACK & VEATCH CONTACT: ANA GOMEZ ADDRESS: 2600 OAK ROAD, SUITE 400 SAN FRANCISCO, CA 94103 PHONE: (415) 438-9148 E-MAIL: ANAGOMEZ@BLACKV.COM
ENGINEER	COMPANY: BLACK & VEATCH ENGINEER: ARON EVANS PHONE: (925) 896-0751 E-MAIL: EVANSARON@BLACKV.COM

PROJECT DATA	
LATITUDE	37.784376
LONGITUDE	-122.227997
POLE #	110128033
ELEVATION	NA
ZONING JURISDICTION	CITY OF OAKLAND
NEAREST A.P.N.	RU-5
OCCUPANCY	25-733-1-1
CONSTRUCTION TYPE	U, UNMANNED
TITLE 24 REQUIREMENTS:	ATTACHMENTS TO A WOOD UTILITY POLE
	FACILITY IS UNMANNED AND NOT FOR EACRPT MAINTENANCE. THIS PROJECT IS

CODE COMPLIANCE

ALL WORK AND MATERIALS SHALL BE PERFORMED AND INSTALLED IN ACCORDANCE WITH THE CURRENT EDITIONS OF THE FOLLOWING CODES AS ADOPTED BY THE LOCAL GOVERNING AUTHORITIES (AS APPLICABLE) NOTHING IN THESE DRAWINGS SHALL BE CONSIDERED TO PRECLUDE WORK NOT CONFORMING TO THESE CODES.

- IBC - 2012
- CALIFORNIA BUILDING STANDARDS CODE - 2013
- CALIFORNIA GENERAL ORDER 95
- CALIFORNIA PLUMBING CODE 2013
- CALIFORNIA ELECTRICAL CODE 2013
- CALIFORNIA ELECTRICAL CODE 2013
- CITY AND/OR COUNTY ORDINANCES
- CITY AND/OR COUNTY ORDINANCES
- BUILDING OFFICIALS AND CODE ADMINISTRATORS (BOCA) *EFFECTIVE UNTIL JANUARY 1ST, 2017

PROJECT DESCRIPTION

THESE DRAWINGS DEPICT THE INSTALLATION OF A WIRELESS TELECOMMUNICATIONS NODE IN THE PUBLIC RIGHT OF WAY DESCRIBED HEREIN.

GENERAL PROJECT NOTES

- PRIOR TO SUBMITTING A BID, THE CONTRACTOR SHALL VERIFY ALL DIMENSIONS AND CONDITIONS WITH THE CITY AND COUNTY ENGINEER'S OFFICE.
- CONTRACTOR SHALL VERIFY ALL FIELD CONDITIONS AND DIMENSIONS OF THE JOB SITE AND CONDITIONS CAN BE INDICATED ON THESE CONSTRUCTION DOCUMENTS CAN BE WORK.
- ALL FIELD MODIFICATIONS BEFORE DURING OR AFTER CONSTRUCTION SHALL BE APPROVED IN WRITING BY AN EXTENET SYSTEMS REPRESENTATIVE.
- INSTALL ALL EQUIPMENT AND MATERIALS PER THE OTHERWISE'S RECOMMENDATIONS, UNLESS INDICATED OTHERWISE.
- WORKY EXTENET SYSTEMS IN WRITING OF ANY VIOLATIONS OR DISCREPANCIES REGARDING THE CONTRACT DOCUMENTS, EXISTING CONDITIONS, AND DESIGN INTENT. THE CONTRACTOR SHALL BE RESPONSIBLE FOR VERIFYING ALL FIELD CONDITIONS AND DIMENSIONS WITH THE CITY AND COUNTY ENGINEER'S OFFICE.
- CONTRACTOR SHALL BE SOLELY RESPONSIBLE FOR ALL PROVISIONS OF THE CONTRACT DOCUMENTS, SPECIFICATIONS AND CONDITIONS OF WORK, METHODS, TECHNIQUES, SEQUENCES AND PROCEDURES OF WORK, AND ALL OTHERS.
- CONTRACTOR SHALL PROTECT ALL EXISTING UTILITIES AND DAMAGE THAT MAY OCCUR DURING THE CONSTRUCTION TO THE SITE. THE CONTRACTOR SHALL PROVIDE EXTENSIVE SYSTEMS WITH ONE COPY OF ALL TWO-DIMED DRAWINGS.
- CONTRACTOR BE RESPONSIBLE TO OBTAIN ALL NECESSARY PERMITS AND APPROVALS FROM ALL AGENCIES AND AUTHORITIES.
- REPAIR ALL FIELD EQUIPMENT WITH AN EXTENET SYSTEMS INSTALLATION AND THEIR FINAL LOCATION ARE TO BE APPROVED BY EXTENET SYSTEMS. THE CONTRACTOR SHALL BE RESPONSIBLE FOR VERIFYING ALL FIELD CONDITIONS AND DIMENSIONS WITH THE CITY AND COUNTY ENGINEER'S OFFICE.
- CONTRACTOR SHALL BE RESPONSIBLE FOR OBTAINING ALL NECESSARY PERMITS AND APPROVALS FROM ALL AGENCIES AND AUTHORITIES.

UNDERGROUND SERVICE ALERT

UTILITIES PROTECTION CENTER, INC.
811
48 HOURS BEFORE YOU DIG



INTERNAL REVIEW	
CONSTRUCTION SIGNATURE	DATE
RF SIGNATURE	DATE
REAL ESTATE SIGNATURE	DATE

BLACK & VEATCH
BLACK & VEATCH CORPORATION
2600 OAK ROAD
SAN FRANCISCO, CA 94103
WALNUT CREEK, CA 94597

PROJECT NO	DRAWN BY	CHECKED BY
192417	DMS	DMC

REV	DATE	DESCRIPTION
1	09/27/16	ISSUED FOR REVIEW

PRELIMINARY

IT IS A VIOLATION OF LAW FOR ANY PERSON UNLESS AUTHORIZED UNDER THE PROVISIONS OF THE CALIFORNIA PROFESSIONAL ENGINEERING ACT TO ALTER THIS DOCUMENT.

EXTENET SYSTEMS (CA) LLC
2000 CROW CANYON PLACE
SAN RAMON, CA 94583

SITE ADDRESS
ADJACENT TO (IN PROW)
2630 FOOTHILL BOULEVARD
OAKLAND, CA 94601

SHEET TITLE
TITLE SHEET

SHEET NUMBER
T-1

GENERAL NOTES

- THESE NOTES SHALL BE CONSIDERED A PART OF THE WRITTEN SPECIFICATIONS, CONTRACT AND CONSTRUCTION DOCUMENTS.
- THE CONTRACTOR SHALL INQUIRE REGARDING MATERIALS, EQUIPMENT, APPROVED PROCEDURES, AND DESIGN NECESSARY TO COMPLETE ALL INSTALLATIONS AS INDICATED ON THESE PLANS AND IN THE CONTRACT AND CONSTRUCTION DOCUMENTS.
- FOR ALL CONTRACT DOCUMENTS, FIELD CONDITIONS AND DIMENSIONS, THE CONTRACTOR SHALL BE RESPONSIBLE FOR THE VERIFICATION OF THE INFORMATION PROVIDED BY THE ARCHITECT/ENGINEER PRIOR TO THE WORK. THE CONTRACTOR SHALL RECEIVE WRITTEN AUTHORIZATION TO PROCEED ON ANY WORK NOT CLEARLY DEFINED OR DESCRIBED IN THE CONTRACT AND CONSTRUCTION DOCUMENTS BEFORE STARTING ANY WORK.
- ALL WORK PERFORMED AND MATERIALS INSTALLED SHALL BE IN STRICT ACCORDANCE WITH ALL APPLICABLE SPECIFICATIONS.
- THE CONTRACTOR SHALL INSTALL ALL EQUIPMENT AND MATERIALS IN ACCORDANCE WITH MANUFACTURER DOCUMENTS AND/OR APPLICABLE CODES OR REGULATIONS. THE CONTRACTOR SHALL VERIFY WITH THE ARCHITECT/ENGINEER AND ARCHITECT/ENGINEER BEFORE PROCEEDING WITH THE INSTALLATION OF ANY EQUIPMENT AND MATERIALS.
- THE CONTRACTOR SHALL BE SOLELY RESPONSIBLE FOR ALL CONSTRUCTION MEANS, METHODS, TECHNIQUES, PROCEDURES, AND CONSTRUCTION AND CONSTRUCTION DOCUMENTS INCLUDING CONSTRUCTION DOCUMENTS AND CONSTRUCTION DOCUMENTS. THE CONTRACTOR SHALL BE RESPONSIBLE FOR THE PROTECTION OF UTILITIES OR OTHER ADJACENT UTILITIES WITHIN THE LIMITS OF THE WORK, WHETHER THEY ARE IDENTIFIED IN THE CONTRACT DOCUMENTS OR NOT.
- THE CONTRACTOR SHALL NOTIFY UNDERGROUND SERVICE ALERT (800) 227-2600 AT LEAST TWO WORKING DAYS BEFORE THE START OF ANY EXCAVATION.

DEFINITIONS

- "TYPICAL" OR "TYP." MEANS THAT THE ITEM IS SUBSTANTIALLY THE SAME ACROSS SIMILAR CONDITIONS. "TYP." MEANS THAT THE ITEM IS SUBSTANTIALLY THE SAME ACROSS SIMILAR CONDITIONS. "TYP." MEANS THAT THE ITEM IS SUBSTANTIALLY THE SAME ACROSS SIMILAR CONDITIONS.
- "SHALL" MEANS COMPLIANCE TO CHARACTERISTICS FOR THE COMMON WORD. VERY DIMENSIONS AND OBSERVATION ON PLAN.
- "AS REQUIRED" MEANS AS REQUIRED BY REGULATORY REQUIREMENTS, BY REFERENCED STANDARDS, BY EXISTING CONDITIONS, BY GENERALLY ACCEPTED CONSTRUCTION PRACTICES OR BY THE CONTRACT DOCUMENTS.
- "TAJOLN" MEANS ACCURATELY LOCATE FINISH POINTS OF MATERIALS IN THE SAME PLANE.
- THE TERM "START" OR "FINISH" SHALL BE UNDERSTOOD TO MEAN VERY IN FIELD WITH ENGINEER AND RECEIVING DIRECTION. CONSTRUCTION METHOD INCLUDING CONDITION AND PROTECT ONLY AFTER RECEIVING DIRECTION. CONSTRUCTION METHOD INCLUDING CONDITION AND PROTECT ONLY AFTER RECEIVING DIRECTION.
- WHERE THE WORDS "OR EQUAL" OR "OR MORE" OR "SIMILAR" ARE USED IN A MATERIAL SPECIFICATION, THEY SHALL BE UNDERSTOOD TO REQUIRE SELECTION OF AN EQUAL OR BETTER MATERIAL SPECIFICATION. THEY SHALL BE UNDERSTOOD TO REQUIRE SELECTION OF AN EQUAL OR BETTER MATERIAL SPECIFICATION.
- FINISH AND INSTALL. OTHERS TO INSTALL. INSTALL. INSTALL. INSTALL. INSTALL. INSTALL. INSTALL. INSTALL. INSTALL. INSTALL.

FIELD WELDING NOTES:

- WELDING TO BE PERFORMED BY ANS CERTIFIED WELDER FOR THE TYPE OF AND POSITION INDICATED. ALL WORK MUST BE IN CONFORMANCE WITH LATEST EDITION OF AWS D1.1.
- GROUND SURFACES TO BE WELDED WITH A SILICON CARBIDE WHEEL PRIOR TO WELDING TO REMOVE ALL AFTER FINISHING.
- WELDING TECHNIQUE MUST MAINTAIN TEMPERATURE RISE ON THE INSIDE SURFACE OF THE JOINT AND ALSO MAINTAIN A MINIMUM TEMPERATURE OF 300°F ON THE OUTSIDE SURFACE. USE AN F70 LOW HYDROGEN WELDING ROD. ALL WELDING RODS MUST BE STORED IN A DRY PLACE AND USED WITHIN 30 DAYS OF OPENING THE ELECTRODES FROM MANUFACTURER'S PACKAGING UNIT. READY FOR IMMEDIATE USE.
- WELDING MAY PRODUCE TOXIC FUMES REFER TO AWS STANDARD Z49.1 "SAFETY IN WELDING AND CUTTING".
- UPON COMPLETION OF WELDING, ALL SURFACES SHALL BE CLEANED TO ALL UNDERSTANDING SURFACES. AFTER RECEIVING, SPAY A FINAL COAT OF COMPATIBLE PAINT TO MATCH SURROUNDING SURFACES.

ANTENNA MOUNTING

- DESIGN AND CONSTRUCTION OF ANTENNA SUPPORTS SHALL CONFORM TO CURRENT AWS/714-222 OR APPLICABLE LOCAL CODES.
- ALL STEEL MATERIALS SHALL BE GALVANIZED AFTER FABRICATION IN ACCORDANCE WITH ASTM A133 ZINC (HOT-DIP GALVANIZED) COATINGS ON IRON AND STEEL PRODUCTS. UNLESS NOTED OTHERWISE.
- ALL BOLTS, NUTS AND FASTENERS SHALL BE GALVANIZED IN ACCORDANCE WITH ASTM A153 ZINC-COATING (HOT-DIP) ON IRON AND STEEL PRODUCTS. UNLESS NOTED OTHERWISE.
- DRAWN GALVANIZED SURFACES SHALL BE REPAIRED BY COLD GALVANIZING IN ACCORDANCE WITH ASTM A780 MANUFACTURER'S RECOMMENDATIONS.
- CONTRACTOR SHALL INSTALL ANTENNA PER MANUFACTURER'S RECOMMENDATION FOR INSTALLATION AND GROUNDING.
- BEFORE SETTING ANTENNA ASSEMBLY AND DOWNWELL, ANTENNA CONTRACTOR SHALL CHECK THE ANTENNA NORTH AND BEARING OF DOWNWELL. THE CENTER POINT ANTENNA ASSEMBLY SHALL BE SET FROM THE NORTH AND BEARING OF DOWNWELL. THE CENTER POINT ANTENNA ASSEMBLY SHALL BE SET FROM THE NORTH AND BEARING OF DOWNWELL. THE CENTER POINT ANTENNA ASSEMBLY SHALL BE SET FROM THE NORTH AND BEARING OF DOWNWELL.

TORQUE REQUIREMENTS

- ALL RF CONNECTIONS SHALL BE TORQUED BY A TORQUE WRENCH.
- ALL RF CONNECTIONS, INCLUDING HARDWARE AND ANTENNA HARDWARE SHALL HAVE A TORQUE MARK INSTALLED IN A RF CONNECTION BOTH SIDES OF THE CONNECTION.
 - GROUNDING AND ANTENNA HARDWARE SHALL BE TORQUED TO THE VALUES LISTED IN THE TABLE.
 - GROUNDING AND ANTENNA HARDWARE SHALL BE TORQUED TO 9 LB-FT (12 NM).
 - ALL 1/2" ANTENNA HARDWARE SHALL BE TORQUED TO 43 LB-FT (58 NM).
 - ALL GROUNDING HARDWARE SHALL BE TORQUED UNTIL THE LOCK WASHER COLLAPSES AND THE GROUNDING HARDWARE IS TO STRESS LEVELS.
- ALL 1/2" TYPE CONNECTIONS SHALL BE TORQUED TO 15-20 LB-IN (1.7 - 2.3 NM).
- ALL 1/4" TYPE CONNECTIONS SHALL BE TORQUED TO 15-20 LB-IN (1.7 - 2.3 NM).

ROW UTILITY POLE CONSTRUCTION NOTES

- NO BOLT HEADS TO PROTRUDE MORE THAN 1-1/2" (38MM).
- FILL ALL HOLES LEFT IN POLE FOR REINFORCEMENT OF CLAMBERS.
- ALL CLAMBER STEPS MUST BE CONSIDERED AS WALKING SURFACES.
- CABLE NOT TO INTERFERE 15" (381MM) CLEAR SPACE OFF POLE FACE (1200).
- 90 DEGREE BENDS UNDER ANTENNA JAW. ALL CABLES MUST ONLY TENSION ON THE INSIDE OR BOTTOM OF JAW (NO BEND ON TOP OF JAW).
- USE 90 CONNECTOR AT CABLE CONNECTION TO ANTENNAS.
- USE 1/2" (12.7MM) CABLE ON ANTENNAS UNLESS OTHERWISE SPECIFIED.
- FILL VOID AROUND CABLES AT CONDUIT OPENING WITH FOAM SEALANT TO PREVENT WATER INTRUSION.

NODE SITE POWER SHUT DOWN PROCEDURES

- FOR NON EMERGENCY/SCHEDULED POWER SHUT DOWN
 - CALL EXTENT SYSTEMS NOT (NETWORK OPERATIONS CENTER) (866)982-5327
 - 24 HOURS PRIOR TO SCHEDULED POWER SHUT OFF
 - PROVIDE THE FOLLOWING INFORMATION:
 - NODE SITE NUMBER IDENTIFIED ON SITE NUMBERING STICKER
 - NODE SITE NUMBER IDENTIFIED ON POWER SHUT OFF
 - PROVIDE DURATION OF OUTAGE
 - UNLOCK DISCONNECT BOX. TAP BOTH BREAKERS TO THE OFF POSITION
 - POWER SHUT OFF VERIFICATION WITH APPROVED POLE PROCEDURES
 - NOTIFY EXTENT NOT UPON COMPLETION OF WORK
 - REINSTALL LOCK ON DISCONNECT BOX
- EMERGENCY POWER SHUT OFF
 - CALL EXTENT SYSTEMS NOT (NETWORK OPERATIONS CENTER) (866)982-5327
 - PROVIDE THE FOLLOWING INFORMATION:
 - NODE SITE NUMBER IDENTIFIED ON SITE NUMBERING STICKER
 - NODE SITE NUMBER IDENTIFIED ON POWER SHUT OFF
 - PROVIDE DURATION OF OUTAGE
 - UNLOCK DISCONNECT BOX. TAP BOTH BREAKERS TO THE OFF POSITION
 - POWER SHUT OFF VERIFICATION WITH APPROVED POLE PROCEDURES
 - NOTIFY EXTENT NOT UPON COMPLETION OF WORK
 - REINSTALL LOCK ON DISCONNECT BOX

LEGEND

- EXPOSURE CONNECTION
- Mechanical Connection
- Chemical/Electrolytic Grounding System
- Test Chemical/Electrolytic Grounding System
- Exposure with Inspection Slit
- Grounding Bar
- Grounding Rod
- Test Ground Rod with Inspection Slit
- Chainlink Fence
- Wood/Wrought Iron Fence
- Wall Structure
- Least Area
- Property Line (PL)
- Setbacks
- Water Line
- Underground Power
- Underground Telco
- Underground Fiber
- Overhead Power
- Overhead Telco
- Underground Power
- Above Ground Power
- Above Ground Telco
- Above Ground Telco/Power
- Section Reference
- Detail Reference

PROJECT NO. **DMS** / DRAWN BY **CLC**

DATE **09/27/16** / 5500 FOR REVIEW

REV. **1** / DATE **09/27/16** / DESCRIPTION

PRELIMINARY

IF A VARIATION OF LAW FOR ANY REGION, THE USE OF A STANDARD PROFESSIONAL INDEPENDENT INSTEAD OF THIS DOCUMENT.

EXTENT SYSTEMS (CA) LLC

2000 CROW CANYON PLACE
SUITE 210
SAN RAMON, CA 94583

SHEET TITLE

GENERAL NOTES
AND LEGEND

GN-1

SHEET NUMBER

BLACK & VEATCH

BLACK & VEATCH CORPORATION
2999 DAN ROAD
WALNUT CREEK, CA 94597

INTERNAL REVIEW

CONSTRUCTION SIGNATURE _____ DATE _____

RF SIGNATURE _____ DATE _____

REAL ESTATE SIGNATURE _____ DATE _____

extenel

Connectivity
Systems
Everywhere

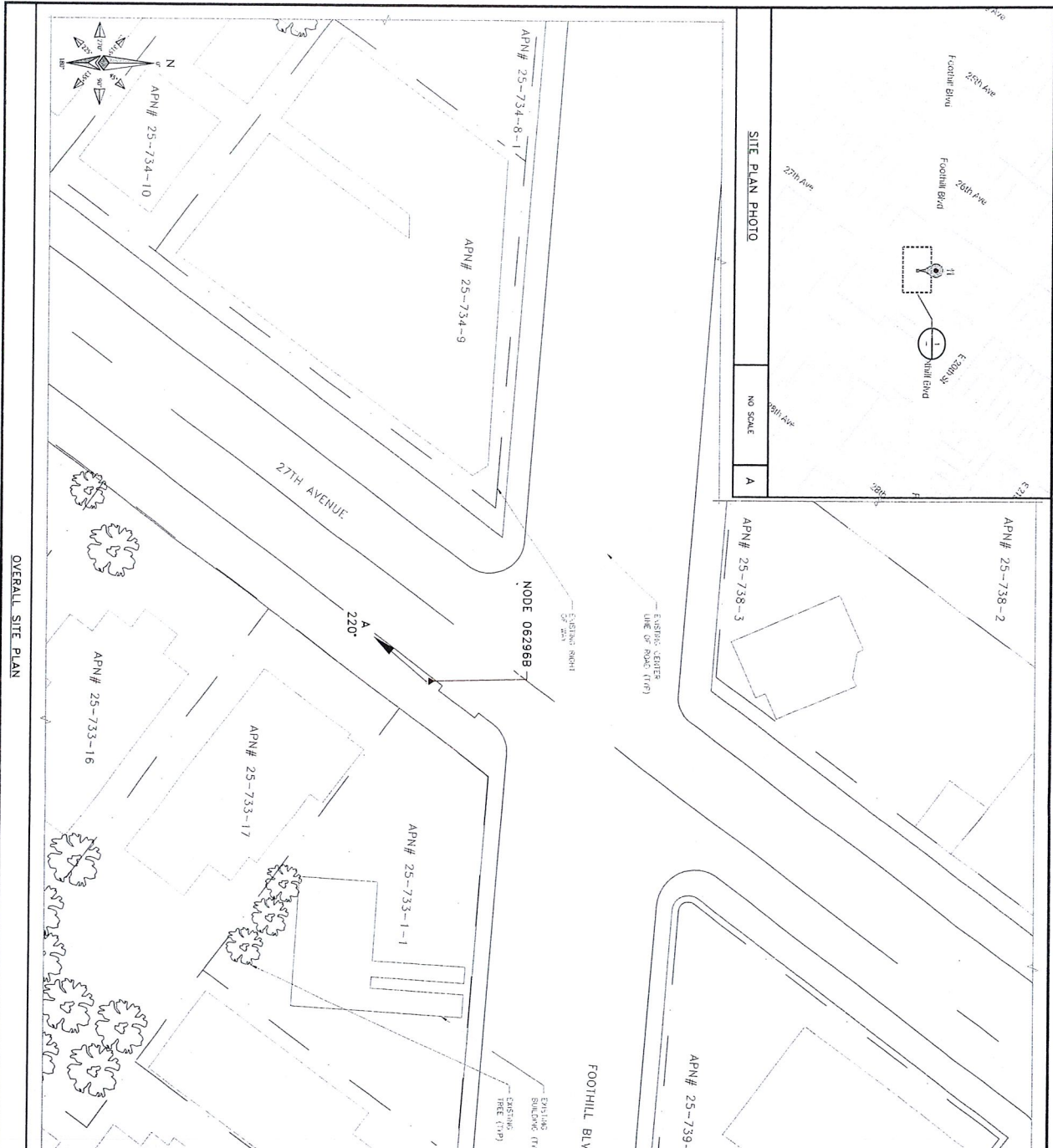

SITE PLAN PHOTO

NO SCALE

A

APN# 25-738-3

APN# 25-738-2

APN# 25-739-1

THIS DRAWING IS NOT A SITE SURVEY. THE PURPOSE OF THIS DRAWING IS TO SHOW HOW THE DEVELOPED SITE RELATES TO ADJACENT PROPERTIES. ROW AND MEASUREMENTS ARE APPROXIMATIONS.

OVERALL SITE PLAN

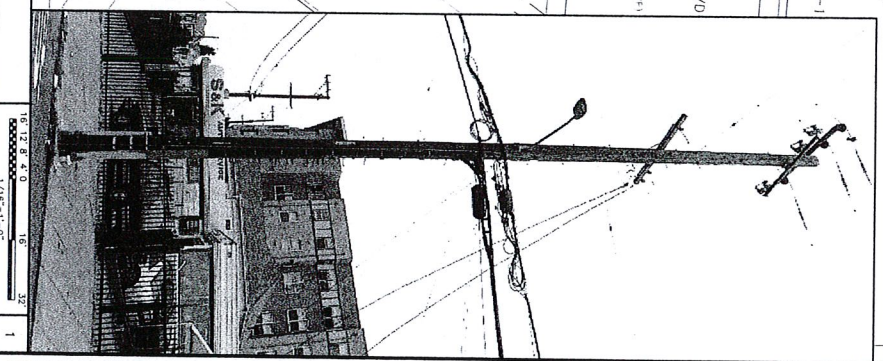

16.128 x 0.0
1/16" = 1'-0"

1

extenet
interconnectivity
SYSTEMS
EVERETT

INTERNAL REVIEW
CONSTRUCTION SIGNATURE _____ DATE _____
RF SIGNATURE _____ DATE _____
REAL ESTATE SIGNATURE _____ DATE _____



BLACK & VEATCH
BLACK & VEATCH CORPORATION
2999 OAK ROAD
SUITE 400
WALNUT CREEK, CA 94597

THESE DRAWINGS ARE COMPUTER GENERATED AND ARE THE PROPERTY OF BLACK & VEATCH. NO PART OF THESE DRAWINGS OR THE INFORMATION CONTAINED THEREIN AND ANY RIGHTS THEREIN ARE TO BE REPRODUCED OR TRANSMITTED IN ANY FORM OR BY ANY MEANS, ELECTRONIC OR MECHANICAL, INCLUDING PHOTOCOPYING, RECORDING, OR BY ANY INFORMATION STORAGE AND RETRIEVAL SYSTEM, WITHOUT THE WRITTEN PERMISSION OF BLACK & VEATCH.

PROJECT NO. DRAWN BY CHECKED BY
192417 DMS GAC

REV	DATE	DESCRIPTION
A	09/27/16	ISSUED FOR REVIEW

PRELIMINARY

IT IS A VIOLATION OF LAW FOR ANY PERSON, FIRM OR CORPORATION TO REPRODUCE OR TRANSMIT IN ANY FORM OR BY ANY MEANS, ELECTRONIC OR MECHANICAL, INCLUDING PHOTOCOPYING, RECORDING, OR BY ANY INFORMATION STORAGE AND RETRIEVAL SYSTEM, WITHOUT THE WRITTEN PERMISSION OF BLACK & VEATCH.

EXTENET SYSTEMS (CA) LLC
2000 CROW CANYON PLACE
SUITE 210
SAN RAMON, CA 94583

SITE ADDRESS
ADJACENT TO (IN PROW)
2630 FOOTHILL BOULEVARD
OAKLAND, CA 94601

SHEET TITLE
OVERALL SITE PLAN

SHEET NUMBER
C-1

NOTE: DRAWINGS HAVE BEEN CREATED BASED ON THE ASSUMPTION THAT THE STRUCTURE HAS SUFFICIENT CAPACITY TO SUPPORT THE PROPOSED LOADING. IT IS THE RESPONSIBILITY OF THE POLE OWNER TO VERIFY THE STRUCTURE'S CAPACITY WITHIN THE ORIGINAL DESIGN CAPACITY OF THE STRUCTURE.

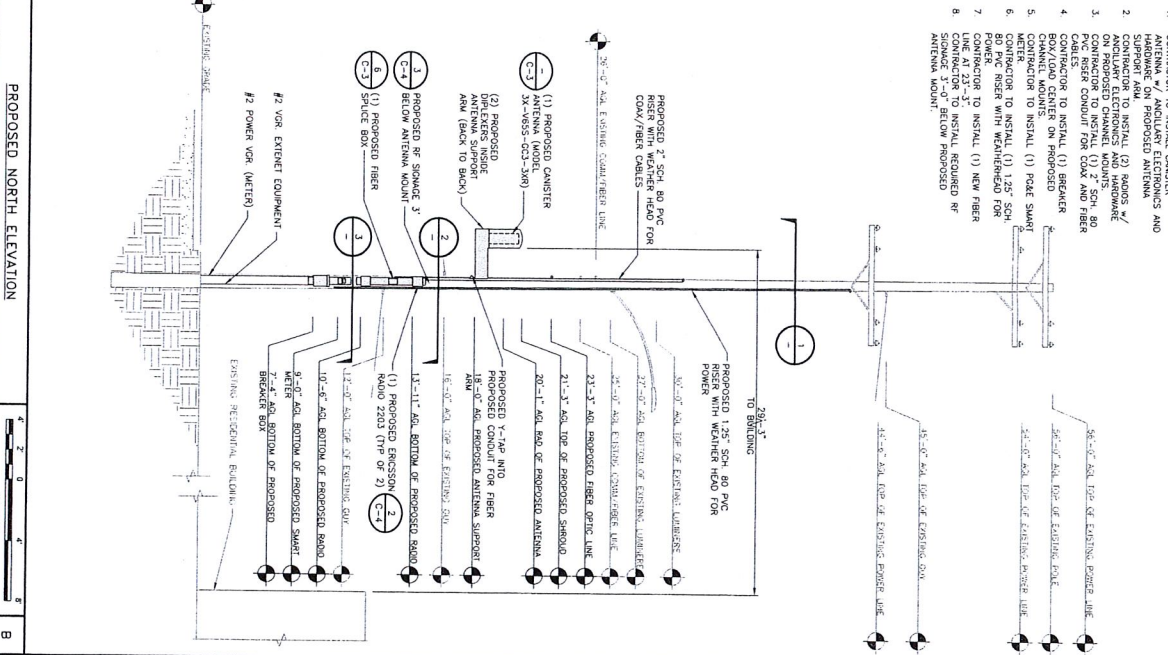
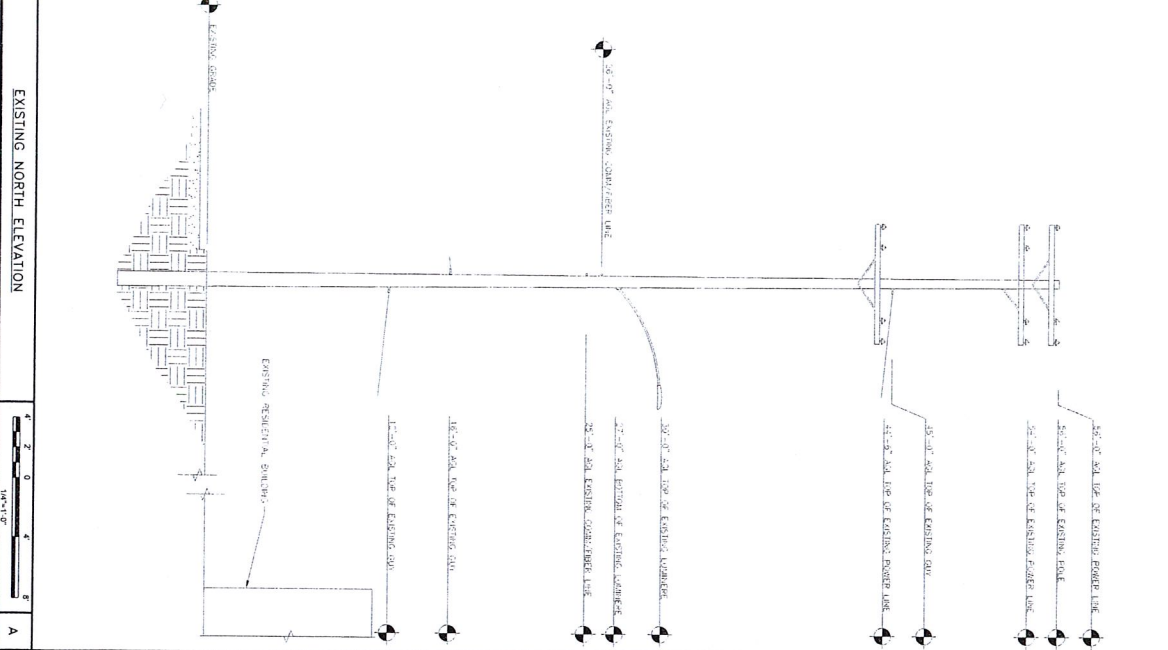

- NOTE
- ALL PROPOSED EQUIPMENT TO BE PAINTED TO MATCH EXISTING CARRIER MOUNT-READY CONDITIONS.
 - CONTRACTOR TO INSTALL CASTER AND SUPPORT ARM.
 - INSTALL (2) PAGES OF ANGLULAR ELECTRONICS AND HARDWARE ON PROPOSED CHANNEL MOUNTS.
 - INSTALL (2) PAGES OF ANGLULAR ELECTRONICS AND HARDWARE ON PROPOSED RISER CONDUIT FOR COAX AND FIBER CABLES.
 - CONTRACTOR TO INSTALL (1) BREAKER CHANNEL MOUNTS.
 - CONTRACTOR TO INSTALL (1) POLE SMART METER.
 - CONTRACTOR TO INSTALL (1) NEW FIBER RISER WITH WEATHERHEAD FOR POWER.
 - CONTRACTOR TO INSTALL (1) NEW FIBER CONDUIT TO INSTALL REQUIRED R/S CONDUIT 3'-0" BELOW PROPOSED ANTENNA MOUNT.

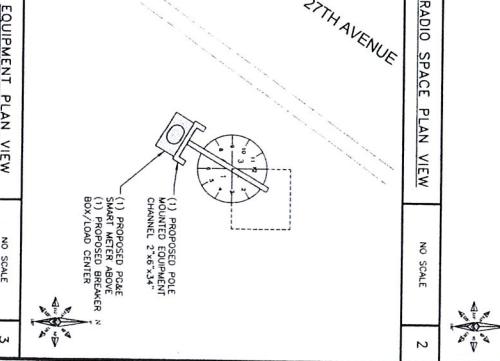
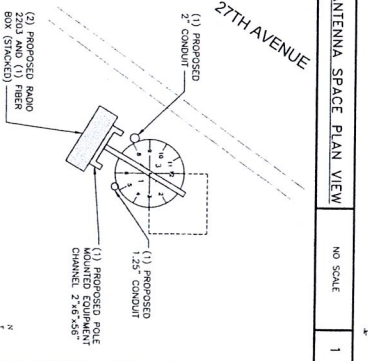
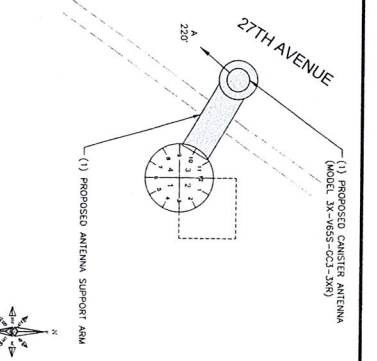

INTERNAL REVIEW	DATE
CONSTRUCTION SIGNATURE	DATE
RF SIGNATURE	DATE
REAL ESTATE SIGNATURE	DATE

exteneif community
SYSTEMS Environment

BLACK & VEATCH
BLACK & VEATCH CORPORATION
2301 S. RIVER ST.
SULTE 400
WALNUT CREEK, CA 94597

PROJECT NO. DRAWN BY CHECKED BY

192417	DMS	GAC
--------	-----	-----

REV.	DATE	DESCRIPTION
A	09/27/16	ISSUED FOR REVIEW

PRELIMINARY

IF IT IS A VIOLATION OF LAW AND ANY STATUTE, UNLESS THE ENGINEER HAS BEEN ADVISED IN WRITING BY THE CLIENT, THE ENGINEER SHALL NOT BE RESPONSIBLE FOR A FAILURE TO ALTER THIS DOCUMENT.

EXTENET SYSTEMS (CA) LLC
2000 CROW CANYON PLACE
SUITE 210
SAN RAMON, CA 94583

SITE ADDRESS
ADJACENT TO (IN PROW)
2630 FOOTHILL BOULEVARD
OAKLAND, CA 94601

SHEET TITLE
UTILITY POLE ELEVATIONS
AND RISER DETAILS

SHEET NUMBER
C-2

COMMSCOPE 3X-1655-GC3-3XR

RF CONNECTOR QUANTITY: 6

RF CONNECTOR LOCATION: BOTTOM

CONNECTOR INTERFACE: 41-9.5 OH FEMALE

TOTAL WEIGHT (WITHOUT BRACKETS): 7.2 kg (15.9 LB)

HEIGHT: 23.5" (596mm)

DIAMETER: 7.9" (200mm)

RF CONNECTOR QUANTITY: 6

RF CONNECTOR LOCATION: BOTTOM

CONNECTOR INTERFACE: 41-9.5 OH FEMALE

TOTAL WEIGHT (WITHOUT BRACKETS): 7.2 kg (15.9 LB)

HEIGHT: 23.5" (596mm)

DIAMETER: 7.9" (200mm)

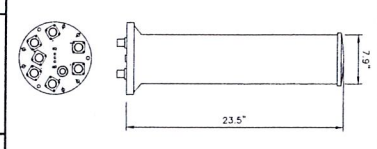

PROPOSED ANTENNA

NO SCALE 1

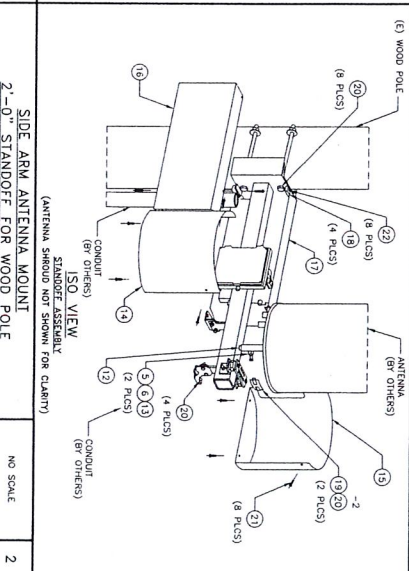

SIDE ARM ANTENNA MOUNT

NO SCALE 2

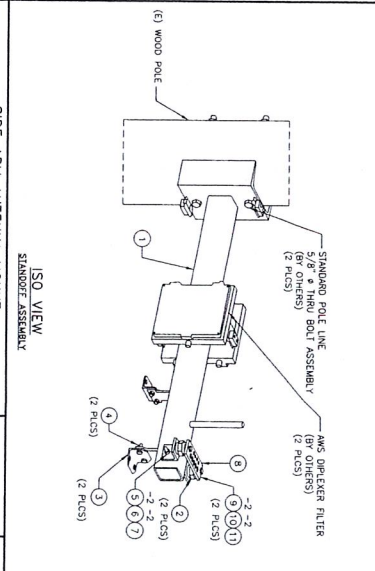
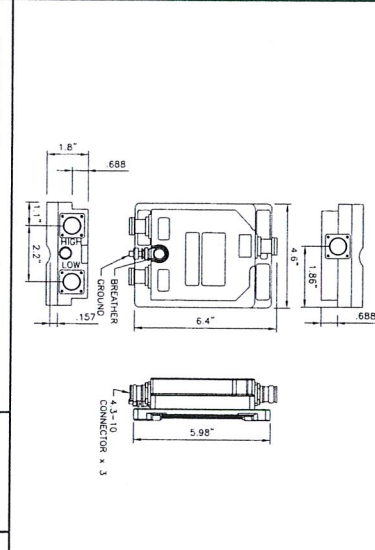

SIDE ARM ANTENNA MOUNT

NO SCALE 5

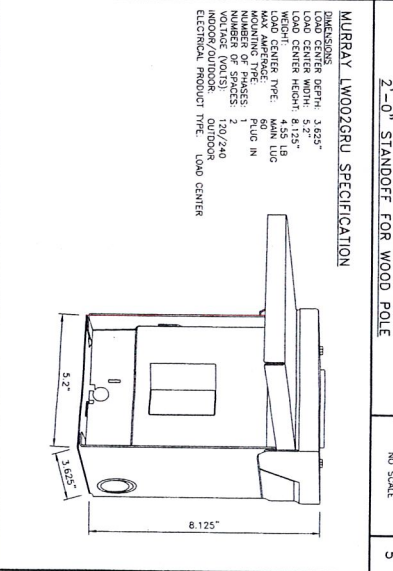
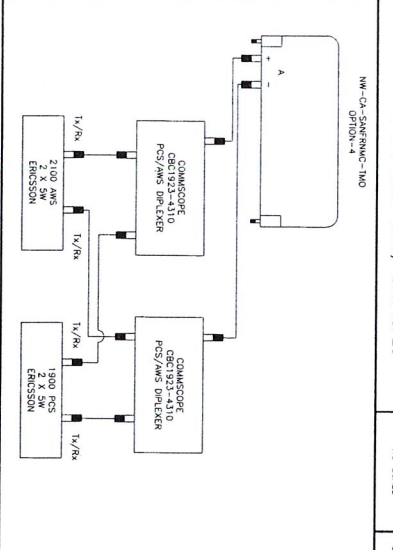

SIDE ARM ANTENNA MOUNT

NO SCALE 8

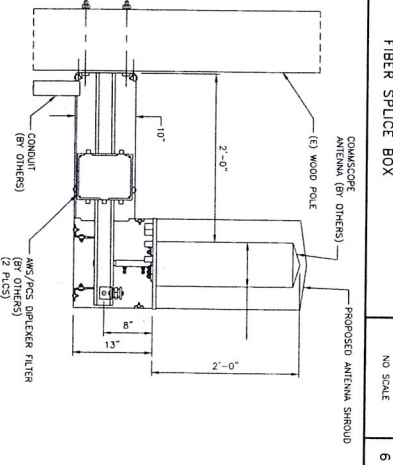

SIDE ARM ANTENNA MOUNT

NO SCALE 9

ANTENNA SHROUD PARTS TABLE

ITEM #	PART #	DESCRIPTION	QTY.	UNIT WT. (lbs)
1	WA-714	STANDOFF ARM ASSEMBLY PARTS/HOME	1	4.3
2	SS-514	3"x3/4"x1/8"x3/4" 304 SS ANGLE	2	0.5
3	SS-516	2"x2"x1/4"x3/4" 304 SS ANGLE	2	0.4
4	15230	3/8"x1" A307 FULLY THRO BOLT/INT/LW CALV	4	0.1
5	41010	3/8"x1" A307-A HEX NUT CALV	2	0.01
6	51000	3/8"x1" A307-A HEX NUT CALV	2	0.01
7	80316	3/8"x1" A307 THRO BOLT CALV	1	0.19
8	FL-718	BUS BAR ASSEMBLY PARTS / HOME	1	0.8
9	43010	3/8" LOCK WASHER BUS BAR	4	0.01
10	71017	3/8"x5/8" FULLY THRO S.S. BOLT	4	0.04
11	90660	ANTENNA / EQUIPMENT INSULATOR (598640)	2	0.1
12	WA-698	3/8"x7" OD AXE TOP CAP W/COAT	1	2.2
13	16206	3/8"x1" 1/2" A307 FULLY THRO BOLT CALV	2	0.01
14	41010	3/8" LOCK WASHER CALV	2	0.01
15	51000	3/8" A307 HEX NUT CALV	2	0.02
16	WA-156	1/4"x1.1/2"x1/4" 304 SS E.C. FORMED BATE W/COAT	1	8
17	FL-126	1/4"x1.1/2"x1/4" 304 SS E.C. FORMED BATE W/COAT	1	8.9
18	FL-128	1/4"x1.1/2"x1/4" 304 SS E.C. FORMED COVER	1	0.1
19	1408-4	1/2"x1.1/2"x1/4" 304 SS E.C. FORMED COVER	4	0.1
20	55500	1/4"x3" 304 SS THRO BOLT/INT/NO SHRT CAP SCRW	16	0.02
21	70212	1/4"x3" 304 SS THRO BOLT/INT/NO SHRT CAP SCRW	16	0.02
22	70218	1/4"x3" 1/4" 304 THRO BOLT/INT/NO SHRT CAP SCRW	16	0.003

TOTAL CALV WT = 88lbs

ANTENNA SHROUD PARTS TABLE

NO SCALE 3

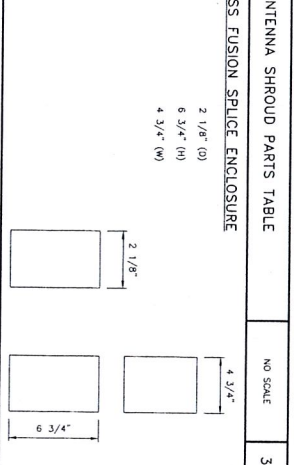

FIBER SPLICE BOX

NO SCALE 6

PRELIMINARY

IF IS A VIOLATION OF LAW FOR ANY REASON, THE USER SHALL BE RESPONSIBLE FOR OBTAINING NECESSARY PERMITS AND APPROVALS TO ALTER THIS DOCUMENT.

EXTENET SYSTEMS (CA) LLC
 2000 CROW CANYON PLACE
 SUITE 210
 SAN RAMON, CA 94553

SITE ADDRESS:
 ADJACENT TO (IN PROW)
 2630 FOOTHILL BOULEVARD
 OAKLAND, CA 94601

SHEET TITLE:
EQUIPMENT DETAILS

SHEET NUMBER:
C-3

BLACK & VEATCH

BLACK & VEATCH CORPORATION
 2999 OAK ROAD
 WALNUT CREEK, CA 94597

INTERNAL REVIEW: DATE

CONSTRUCTION SIGNATURE: DATE

RF SIGNATURE: DATE

REAL ESTATE SIGNATURE: DATE

PROJECT NO: 192417
 DMS: DMC
 CHECKED BY: []
 DATE: 09/27/16
 ISSUED FOR REVIEW: []
 DATE: []

THESE DRAWINGS ARE COMPUTER AID AND ARE THE PROPERTY OF BLACK & VEATCH. NO PART OF THESE DRAWINGS IS TO BE REPRODUCED OR TRANSMITTED IN ANY FORM OR BY ANY MEANS, ELECTRONIC OR MECHANICAL, INCLUDING PHOTOCOPYING, RECORDING, OR BY ANY INFORMATION STORAGE AND RETRIEVAL SYSTEM, WITHOUT THE WRITTEN CONSENT OF BLACK & VEATCH.

LEGEND

- ① ANTENNA
- ② STEEL ANTENNA EXTENSION ARM
- ③ COUPLER
- ④ WIRE
- ⑤ MAIN GROUND BUSS BAR
- ⑥ INTERMEDIATE GROUND BUSS BAR
- ⑦ POLE MOUNTING EQUIPMENT BACKPLATE

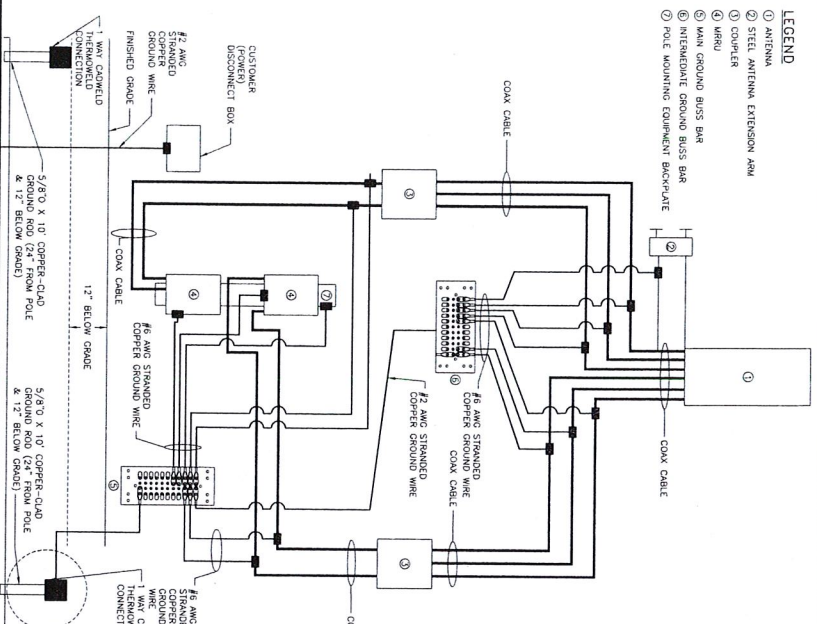

CONCEPTUAL WOOD POLE GROUNDING DETAIL

ERISSON RADIO 2203

LENGTH: 7'8" (200MM)
 WIDTH: 7'8" (200MM)
 DEPTH: 3'3" (100MM)
 TOTAL WEIGHT (WITHOUT BRACKETS): <4.5 kg

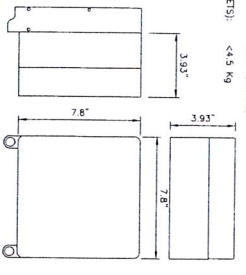

RADIO SPECIFICATION DETAIL

GENERAL GROUNDING NOTES

1. #6 GREEN COATED WIRE TO BE USED.
2. GROUND (COMPRESSION) TYPE TWO HOLE FASTENED TONGUE CONNECTIONS SHALL BE USED TO TERMINATE STRANDED GROUND CONDUCTORS.
3. GROUND WIRES SHALL BE INSERTED ON THE ENTIRE LENGTH OF THE LUG.
4. GROUND CONDUCTORS COMPANED ON THE CONDUCTOR BEFORE COMPLETING ALL CONNECTIONS.
5. HARD WOOD OR DOUGLAS FIR WOOD MOUNTING CORROSION RESISTANT (GALVANIZED) STEEL AT 2' INTERVALS TO BE USED FOR VERTICAL SUPPORTS.
6. BOND WIRES AND GROUND WIRES SHALL HAVE A CLEARANCE OF NOT LESS THAN 1/2" FROM METAL PINS, BRACKETS, AND OTHER HARDWARE.
7. ALL CONNECTIONS SHALL BE MADE TO THE BOND OR GROUND WIRES, AND WHEN USED AS CONNECTOR DOES NOT VIOLATE OTHER RULES OF CODES. IN ALL CASES, THE CONNECTION SHALL BE MADE TO THE BOND OR GROUND WIRES.
8. BE MOUNTED DIRECTLY TO POLE MOUNTING EQUIPMENT AND NOT TO ATTACHMENTS.
9. GROUND BUSS BAR LENGTH TO VARY BASED ON NUMBER OF GROUND ATTACHMENTS.
10. USE GROUND LUG TO BOND ANTENNA SUPPORT ARM TO BSB.

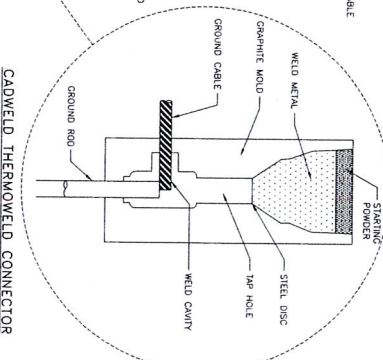

CADWELD THERMOWELD CONNECTOR

NOTICE



Beyond This Point you are entering a controlled area where RF emissions may exceed the FCC General Population Exposure Limits. Follow all posted signs and site guidelines for working in a RF environment.

CAUTION



Beyond This Point you are entering a controlled area where RF emissions may exceed the FCC Occupational Exposure Limits. Obey all posted signs and site guidelines for working in a RF environment.

RF SIGNAGE DETAIL

RF SIGNAGE DETAIL

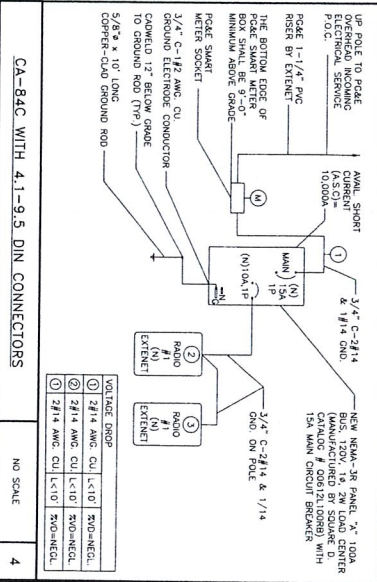

CA-84C WITH 4.1-9.5 DIN CONNECTORS

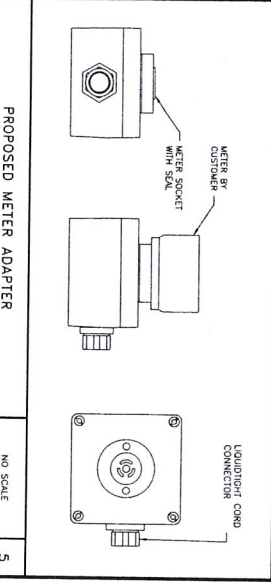

PROPOSED METER ADAPTER

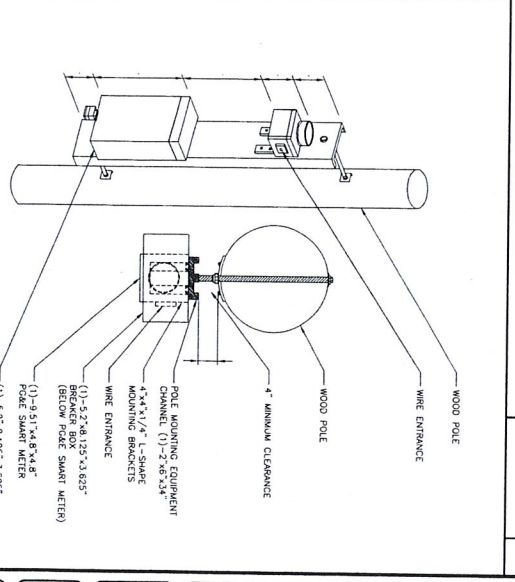

SMART METER/BREAKER BOX DETAIL

extenei re-connectivity systems

INTERNAL REVIEW _____ DATE _____
 CONSTRUCTION SIGNATURE _____ DATE _____
 RF SIGNATURE _____ DATE _____
 REAL ESTATE SIGNATURE _____ DATE _____

BLACK & VEATCH
 BLACK & VEATCH CORPORATION
 2999 OAK ROAD
 WALNUT CREEK, CA 94597

THESE DRAWINGS ARE COMPUTER GENERATED AND PRODUCED SOLELY FOR THE USE OF OUR INFORMATION CONSTRUCTION DIVISION. THE DRAWINGS IS REPRODUCED WITHOUT ANY WARRANTIES OR CONDITIONS BY BLACK & VEATCH.

PROJECT NO	3000 CROW	BY	CHECKED BY
132417		DMS	DAC
REV	DATE	ISSUED FOR REVIEW	DESCRIPTION
A	09/27/18		

PRELIMINARY

IF IS A VIOLATION OF LAW FOR ANY PERSON, UNLESS THEY ARE AGING UNDER THE DIRECTION OF AN ENGINEER, TO ALTER THIS DOCUMENT.

EXTENET SYSTEMS (CA) LLC
 2000 CROW CANYON PLACE
 SUITE 210
 SAN RAMON, CA 94583

SITE ADDRESS
 ADJACENT TO (IN PROX)
 2630 FOOTHILL BOULEVARD
 OAKLAND, CA 94601

SHEET TITLE
EQUIPMENT DETAILS

SHEET NUMBER
C-4

Attachment D





Existing



proposed antenna

Proposed



Existing



Proposed



**EXTENET OAKLAND
NODE 06044A
ALTERNATIVE SITE ANALYSIS**

ATTACHMENT E

MAP OF ALTERNATIVE POLES EVALUATED FOR NODE 06044A



- The above maps depict ExteneNet's proposed Node 06044A in relation to other poles in the area that were evaluated as possibly being viable alternative candidates.
- The following is an analysis of each of those 3 alternative locations.

PROPAGATION MAP OF NODES 06044A

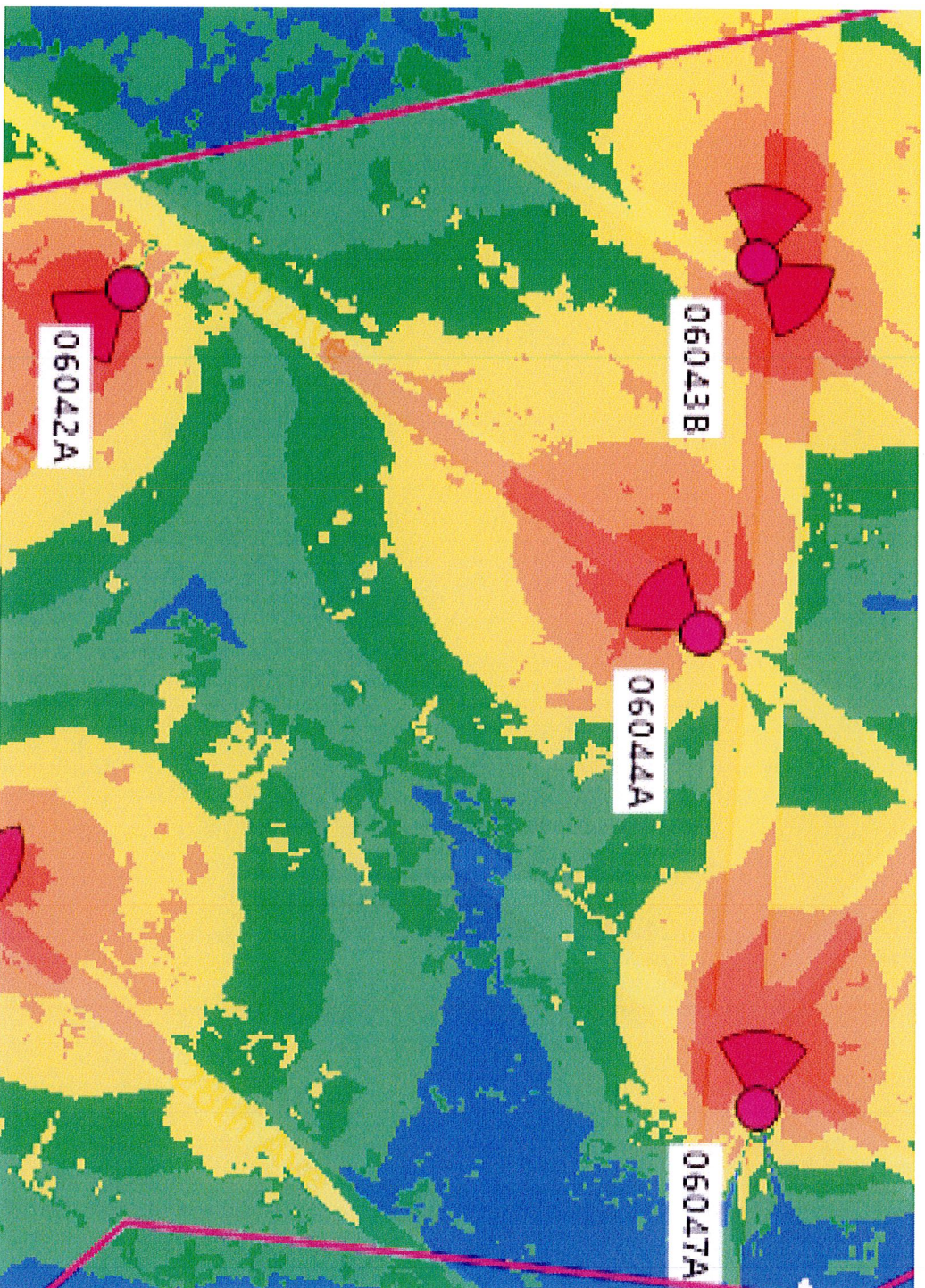

This propagation map depicts the ExtNet proposed Node 06044A in relation to surrounding proposed ExtNet small cell nodes.

06044A - PROPOSED LOCATION



- The location for ExteNet's proposed Node 06044A is a joint utility pole located adjacent to PROW at 2701 Foothill Boulevard (37.784376, - 122.227999).
- ExteNet's objective is to provide T-Mobile 4G wireless coverage and capacity to the Oakland area.
- ExteNet evaluated this site and nearby alternatives to verify that the selected site is the least intrusive means to close T-Mobile's significant service coverage gap.

ALTERNATIVE NODE 06044B



- Node 06044B is a metal light pole at 2630 Foothill Boulevard (37.784608, -122.228041).
- This pole is not a viable alternative candidate because the existing pole does not have telco in order to facilitate our proposed wireless installation. The existing pole will need to be replaced by a taller pole.
- This pole is not a viable alternative candidate because this pole is located too close to primary Node 06043B.

ALTERNATIVE NODE 06044C

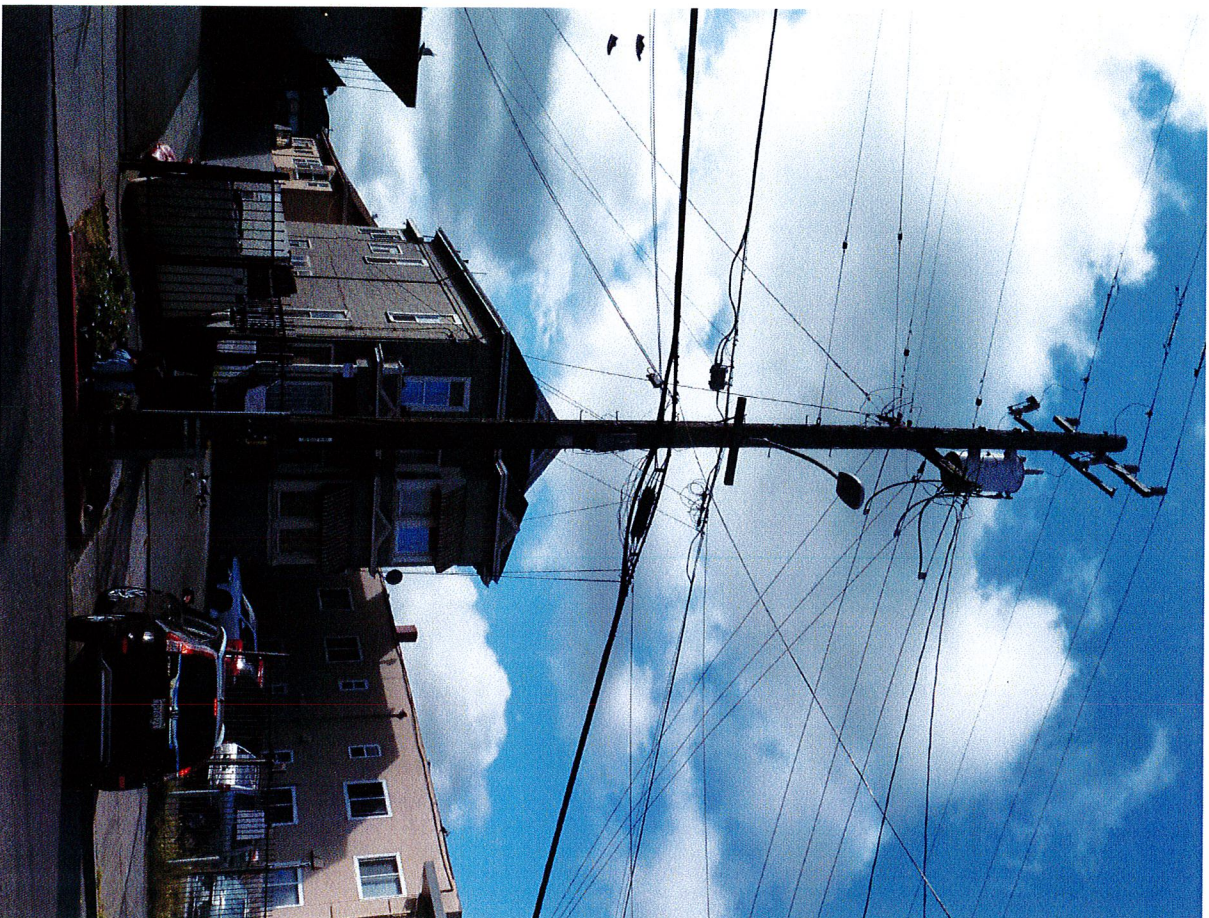

- Node 06044C is a joint utility pole at 1760-1766 27th Avenue (37.784017, -122.228258)
- This pole is not a viable alternative candidate because cross lines and cross arms prevent adequate climbing space on the pole pursuant to CPUC General Order 95, thus prohibiting a wireless facility from being installed at this location.
- This pole is not a viable alternative candidate because the existing transformer on the pole would need to be relocated to an uncertain destination in order to facilitate our proposed wireless installation.
- This pole is not a viable alternative candidate because this pole is located too far from the primary Node 06043B.

ALTERNATIVE NODE 06044D



- Node 06044D is a joint utility pole across from 2701 Foothill Boulevard (37.784568, - 122.227580).
- This pole is not a viable alternative candidate because the existing pole does not have power nor telco in order to facilitate our proposed wireless installation. The existing pole will need to be replaced by a taller pole.
- This pole is not a viable alternative candidate because this pole is located too far from the primary Node 06043B.

ALTERNATIVE SITE ANALYSIS CONCLUSION

Based on ExteneNet's analysis of alternative sites, the currently proposed Node 06044A is the least intrusive location from which to fill the surrounding significant wireless coverage gaps.



extenetSM
SYSTEMS

Thank You!

**ExteNet Systems CA, LLC • Proposed DAS Node (Site No. 06044A)
2701 Foothill Boulevard • Oakland, California**

Statement of Hammett & Edison, Inc., Consulting Engineers

The firm of Hammett & Edison, Inc., Consulting Engineers, has been retained on behalf of ExteNet Systems CA, LLC, a wireless telecommunications carrier, to evaluate the addition of Node No. 06044A to be added to the ExteNet distributed antenna system (“DAS”) in Oakland, California, for compliance with appropriate guidelines limiting human exposure to radio frequency (“RF”) electromagnetic fields.

Executive Summary

ExteNet proposes to install a directional panel antenna on a utility pole sited in the public right-of-way at 2701 Foothill Boulevard in Oakland. The proposed operation will comply with the FCC guidelines limiting public exposure to RF energy.

Prevailing Exposure Standards

The U.S. Congress requires that the Federal Communications Commission (“FCC”) evaluate its actions for possible significant impact on the environment. A summary of the FCC’s exposure limits is shown in Figure 1. These limits apply for continuous exposures and are intended to provide a prudent margin of safety for all persons, regardless of age, gender, size, or health. The most restrictive FCC limit for exposures of unlimited duration to radio frequency energy for several personal wireless services are as follows:

Wireless Service	Frequency Band	Occupational Limit	Public Limit
Microwave (Point-to-Point)	5,000–80,000 MHz	5.00 mW/cm ²	1.00 mW/cm ²
BRS (Broadband Radio)	2,600	5.00	1.00
AWS (Advanced Wireless)	2,100	5.00	1.00
PCS (Personal Communication)	1,950	5.00	1.00
Cellular	870	2.90	0.58
SMR (Specialized Mobile Radio)	855	2.85	0.57
700 MHz	700	2.35	0.47
[most restrictive frequency range]	30–300	1.00	0.20

Power line frequencies (60 Hz) are well below the applicable range of these standards, and there is considered to be no compounding effect from simultaneous exposure to power line and radio frequency fields.

General Facility Requirements

Base stations typically consist of two distinct parts: the electronic transceivers (also called “radios” or “channels”) that are connected to the traditional wired telephone lines, and the passive antennas that send the wireless signals created by the radios out to be received by individual subscriber units. The transceivers are often located at ground level and are connected to the antennas by coaxial cables.

**ExteNet Systems CA, LLC • Proposed DAS Node (Site No. 06044A)
2701 Foothill Boulevard • Oakland, California**

A small antenna for reception of GPS signals is also required, mounted with a clear view of the sky. Because of the short wavelength of the frequencies assigned by the FCC for wireless services, the antennas require line-of-sight paths for their signals to propagate well and so are installed at some height above ground. The antennas are designed to concentrate their energy toward the horizon, with very little energy wasted toward the sky or the ground. This means that it is generally not possible for exposure conditions to approach the maximum permissible exposure limits without being physically very near the antennas.

Computer Modeling Method

The FCC provides direction for determining compliance in its Office of Engineering and Technology Bulletin No. 65, "Evaluating Compliance with FCC-Specified Guidelines for Human Exposure to Radio Frequency Radiation," dated August 1997. Figure 2 attached describes the calculation methodologies, reflecting the facts that a directional antenna's radiation pattern is not fully formed at locations very close by (the "near-field" effect) and that at greater distances the power level from an energy source decreases with the square of the distance from it (the "inverse square law"). The conservative nature of this method for evaluating exposure conditions has been verified by numerous field tests.

Site and Facility Description

Based upon information provided by ExteNet, including drawings by Black & Veatch Corporation, dated September 27, 2016, it is proposed to install one CommScope Model 3X-V65S-GC3-3XR, 2-foot tall, tri-directional cylindrical antenna, with one direction activated, on a cross-arm to be added to a utility pole sited in the public right-of-way near the southeast corner of the intersection of 27th Avenue and Foothill Boulevard in Oakland. The antenna would employ no downtilt, would be mounted at an effective height of about 20 feet above ground, and its principal direction would be oriented toward 220°T. T-Mobile proposes to operate from this facility with a maximum effective radiated power in any direction of 214 watts, representing simultaneous operation 107 watts for AWS and 107 watts for PCS service. There are reported no other wireless telecommunications base stations at this site or nearby.

Study Results

For a person anywhere at ground, the maximum RF exposure level due to the proposed T-Mobile operation is calculated to be 0.0046 mW/cm², which is 0.46% of the applicable public exposure limit. The maximum calculated level at the second-floor elevation of any nearby building is 1.6% of the public exposure limit. It should be noted that these results include several "worst-case" assumptions and therefore are expected to overstate actual power density levels from the proposed operation.

**ExteNet Systems CA, LLC • Proposed DAS Node (Site No. 06044A)
2701 Foothill Boulevard • Oakland, California**

Recommended Mitigation Measures

Due to its mounting location and height, the ExteNet antenna would not be accessible to the general public, and so no mitigation measures are necessary to comply with the FCC public exposure guidelines. To prevent occupational exposures in excess of the FCC guidelines, it is recommended that appropriate RF safety training be provided to all authorized personnel who have access to the antenna, including employees and contractors of the utility companies. No access within 2 feet directly in front of the antenna itself, such as might occur during certain activities, should be allowed while the base station is in operation, unless other measures can be demonstrated to ensure that occupational protection requirements are met. Posting explanatory signs* on the pole at or below the antenna, such that the signs would be readily visible from any angle of approach to persons who might need to work within that distance, would be sufficient to meet FCC-adopted guidelines.

Conclusion

Based on the information and analysis above, it is the undersigned's professional opinion that operation of the node proposed by ExteNet Systems CA, LLC, at 2701 Foothill Boulevard in Oakland, California, will comply with the prevailing standards for limiting public exposure to radio frequency energy and, therefore, will not for this reason cause a significant impact on the environment. The highest calculated level in publicly accessible areas is much less than the prevailing standards allow for exposures of unlimited duration. This finding is consistent with measurements of actual exposure conditions taken at other operating base stations. Training personnel and posting signs is recommended to establish compliance with occupational exposure limitations.

Authorship

The undersigned author of this statement is a qualified Professional Engineer, holding California Registration No. E-18063, which expires on June 30, 2017. This work has been carried out under his direction, and all statements are true and correct of his own knowledge except, where noted, when data has been supplied by others, which data he believes to be correct.

Rajat Mathur
Rajat Mathur, P.E.
707/996-5200

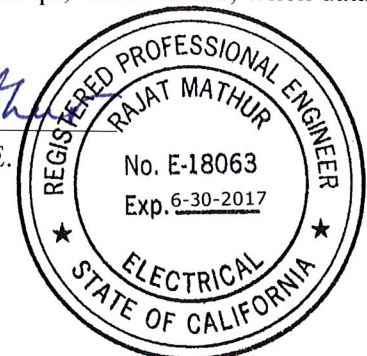

October 25, 2016

* Signs should comply with OET-65 color, symbol, and content recommendations. Contact information should be provided (e.g., a telephone number) to arrange for access to restricted areas. The selection of language(s) is not an engineering matter, and guidance from the landlord, local zoning or health authority, or appropriate professionals may be required. Signage may also need to comply with the requirements of California Public Utilities Commission General Order No. 95.

FCC Radio Frequency Protection Guide

The U.S. Congress required (1996 Telecom Act) the Federal Communications Commission (“FCC”) to adopt a nationwide human exposure standard to ensure that its licensees do not, cumulatively, have a significant impact on the environment. The FCC adopted the limits from Report No. 86, “Biological Effects and Exposure Criteria for Radiofrequency Electromagnetic Fields,” published in 1986 by the Congressionally chartered National Council on Radiation Protection and Measurements (“NCRP”). Separate limits apply for occupational and public exposure conditions, with the latter limits generally five times more restrictive. The more recent standard, developed by the Institute of Electrical and Electronics Engineers and approved as American National Standard ANSI/IEEE C95.1-2006, “Safety Levels with Respect to Human Exposure to Radio Frequency Electromagnetic Fields, 3 kHz to 300 GHz,” includes similar limits. These limits apply for continuous exposures from all sources and are intended to provide a prudent margin of safety for all persons, regardless of age, gender, size, or health.

As shown in the table and chart below, separate limits apply for occupational and public exposure conditions, with the latter limits (in *italics* and/or dashed) up to five times more restrictive:

Frequency Applicable Range (MHz)	Electromagnetic Fields (f is frequency of emission in MHz)					
	Electric Field Strength (V/m)		Magnetic Field Strength (A/m)		Equivalent Far-Field Power Density (mW/cm ²)	
0.3 – 1.34	614	<i>614</i>	1.63	<i>1.63</i>	100	<i>100</i>
1.34 – 3.0	614	<i>823.8/f</i>	1.63	<i>2.19/f</i>	100	<i>180/f²</i>
3.0 – 30	1842/f	<i>823.8/f</i>	4.89/f	<i>2.19/f</i>	900/f ²	<i>180/f²</i>
30 – 300	61.4	<i>27.5</i>	0.163	<i>0.0729</i>	1.0	<i>0.2</i>
300 – 1,500	3.54√f	<i>1.59√f</i>	√f/106	<i>√f/238</i>	f/300	<i>f/1500</i>
1,500 – 100,000	137	<i>61.4</i>	0.364	<i>0.163</i>	5.0	<i>1.0</i>

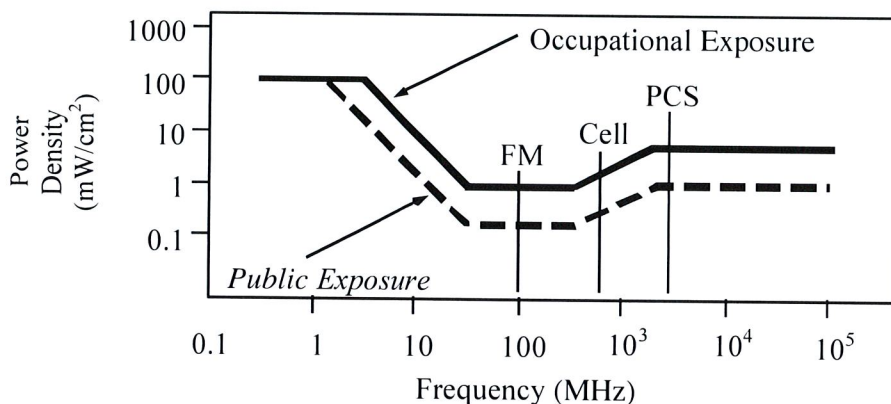

Higher levels are allowed for short periods of time, such that total exposure levels averaged over six or thirty minutes, for occupational or public settings, respectively, do not exceed the limits, and higher levels also are allowed for exposures to small areas, such that the spatially averaged levels do not exceed the limits. However, neither of these allowances is incorporated in the conservative calculation formulas in the FCC Office of Engineering and Technology Bulletin No. 65 (August 1997) for projecting field levels. Hammett & Edison has built those formulas into a proprietary program that calculates, at each location on an arbitrary rectangular grid, the total expected power density from any number of individual radio sources. The program allows for the description of buildings and uneven terrain, if required to obtain more accurate projections.



RFR.CALC™ Calculation Methodology

Assessment by Calculation of Compliance with FCC Exposure Guidelines

The U.S. Congress required (1996 Telecom Act) the Federal Communications Commission (“FCC”) to adopt a nationwide human exposure standard to ensure that its licensees do not, cumulatively, have a significant impact on the environment. The maximum permissible exposure limits adopted by the FCC (see Figure 1) apply for continuous exposures from all sources and are intended to provide a prudent margin of safety for all persons, regardless of age, gender, size, or health. Higher levels are allowed for short periods of time, such that total exposure levels averaged over six or thirty minutes, for occupational or public settings, respectively, do not exceed the limits.

Near Field.

Prediction methods have been developed for the near field zone of panel (directional) and whip (omnidirectional) antennas, typical at wireless telecommunications base stations, as well as dish (aperture) antennas, typically used for microwave links. The antenna patterns are not fully formed in the near field at these antennas, and the FCC Office of Engineering and Technology Bulletin No. 65 (August 1997) gives suitable formulas for calculating power density within such zones.

For a panel or whip antenna, power density $S = \frac{180}{\theta_{BW}} \times \frac{0.1 \times P_{net}}{\pi \times D \times h}$, in mW/cm²,

and for an aperture antenna, maximum power density $S_{max} = \frac{0.1 \times 16 \times \eta \times P_{net}}{\pi \times h^2}$, in mW/cm²,

where θ_{BW} = half-power beamwidth of the antenna, in degrees, and

P_{net} = net power input to the antenna, in watts,

D = distance from antenna, in meters,

h = aperture height of the antenna, in meters, and

η = aperture efficiency (unitless, typically 0.5-0.8).

The factor of 0.1 in the numerators converts to the desired units of power density.

Far Field.

OET-65 gives this formula for calculating power density in the far field of an individual RF source:

power density $S = \frac{2.56 \times 1.64 \times 100 \times RFF^2 \times ERP}{4 \times \pi \times D^2}$, in mW/cm²,

where ERP = total ERP (all polarizations), in kilowatts,

RFF = relative field factor at the direction to the actual point of calculation, and

D = distance from the center of radiation to the point of calculation, in meters.

The factor of 2.56 accounts for the increase in power density due to ground reflection, assuming a reflection coefficient of 1.6 (1.6 x 1.6 = 2.56). The factor of 1.64 is the gain of a half-wave dipole relative to an isotropic radiator. The factor of 100 in the numerator converts to the desired units of power density. This formula has been built into a proprietary program that calculates, at each location on an arbitrary rectangular grid, the total expected power density from any number of individual radiation sources. The program also allows for the description of uneven terrain in the vicinity, to obtain more accurate projections.



February 17, 2017

City Planner
Planning Department
City of Oakland
250 Frank H. Ogawa Plaza, 2nd Floor
Oakland, CA 94612

Re: GO 95 Required Two Feet Clearance between Antenna and Pole
Applicant: ExteNet Systems (California) LLC
Nearest Site Address: Public Right of Way near 2630 Foothill Blvd
Site ID: NW-CA-SANFRNMC-TMO Node 06044A
Latitude/Longitude: 37.784379, -122.227999

Dear City Planner,

This letter is in response to discussions with City of Oakland Planning Department seeking clarification on the proposed antenna placement on the utility pole.

Wireless facility attachments to utility poles must comply with CPUC General Order 95 design, safety and clearance standards. Specifically, Rule 94.4 (E) states: *Antennas shall maintain a 2 ft. horizontal clearance from centerline of pole when affixed between supply and communication lines or below communication lines.* This rule precludes ExteNet from placing the antennas flush mounted to the utility pole when there is a power source attached to the pole. ExteNet minimized the clearance as much as possible by placing the antenna shroud just over two feet from the centerline of the utility pole.

Feel free to contact me if you have any questions. Thank you.

Thank you.

Best Regards,

Ana Gomez/BV for ExteNet

Ana Gomez
ExteNet Permitting Contractor



CITY OF OAKLAND

BUREAU OF PLANNING

250 Frank H. Ogawa Plaza, Suite 2114, Oakland, CA 94612-2031

Phone: 510-238-3911 Fax: 510-238-4730

PLANNING COMMISSION PUBLIC NOTICE

Location:	Utility pole in sidewalk adjacent to: 2701 Foothill Blvd
Assessor's Parcel Number(s):	025-0733-001-01
Proposal:	To establish a new "small cell site" telecommunications facility, in order to enhance existing services, by attaching an antenna and equipment to a wooden utility pole located in the sidewalk.
Applicant / Phone Number:	Ana Gomez/Black & Veatch & Extenet (for: T-Mobile) (913) 458-9148
Owner:	Extenet et al.
Case File Number:	PLN16386
Planning Permits Required:	Regular Design Review with additional findings for Macro Telecommunications Facility
General Plan:	Urban Residential
Zoning:	RU-5 Urban Residential Zone
Environmental Determination:	Exempt, Section 15301 of the State CEQA Guidelines: Existing Facilities; Exempt, Section 15302: Replacement or Reconstruction; Exempt, Section 15303: New Construction of Small Structures; Section 15183: Projects Consistent with a Community Plan, General Plan or Zoning
Historic Status:	Non historic property
City Council District:	5
Date Filed:	November 22, 2016
Action to be Taken:	Decision based on staff report
Finality of Decision:	<i>Appealable to City Council</i>
For Further Information:	Contact case planner Danny Thai at (510) 238-3584 or by email at dthai@oaklandnet.com .

Comments and questions, if any, should be directed to the Bureau of Planning, 250 Frank H. Ogawa Plaza, 2nd Floor, Oakland, California 94612-2031 at or prior to the public hearing to be held on **April 5, 2017**, at Oakland City Hall, Council Chambers, 1 Frank H. Ogawa Plaza, Oakland, California 94612. The public hearing will start at 6:00 p.m.

To challenge the Planning Commission decision on appeal and/or in court, you will be limited to issues raised at the public hearing or in correspondence delivered to the Bureau of Planning, at, or prior to, the public hearing on this case. If you wish to be notified of the decision of any of these cases, please provide the case planner with a regular mail or email address.

Note that the description of the application found above is preliminary in nature and that the project and/or such description may change prior to a decision being made. Where noted, once a decision is reached by the Planning Commission on these cases, they are appealable to the City Council. **Such appeals must be filed within ten (10) business days of the date of decision by the Planning Commission and by 4:00p.m.** An appeal shall be on a form provided by the Bureau of Planning, and submitted to the Bureau of Planning, 250 Frank H. Ogawa Plaza, Suite 2114, to the attention of the Case Planner. The appeal shall state specifically wherein it is claimed there was error or abuse of discretion by the City of Oakland or wherein the decision is not supported by substantial evidence and must include payment in accordance with the City of Oakland Master Fee Schedule. Filing a timely appeal will preclude you from challenging the City's decision in court. The appeal itself must raise every issue that is contested along with all the facts and evidence previously entered into the record prior to or at the public hearing mentioned above. Failure to do so will preclude you from raising such issues during the public hearing and/or in court.

POSTING DATE: **March 17, 2017**

IT IS UNLAWFUL TO ALTER OR REMOVE THIS NOTICE WHEN POSTED ON SITE

ATTACHMENT H

