

Location:	The Public Right -of-Way near 222 19th Street
Assessor's Parcel Numbers:	Adjacent to: 008-0634-003-00
Proposal:	Installation of a wireless "small cell site" telecommunication facility on an existing 27' tall City street light pole located in the public right-of-way. The project involves installation of one (1) antenna measuring 24" long and 14.6" in diameter located within shroud at a height of 31'-2" and two radio units (12.05" wide and 27.17" tall and 7.01" deep) mounted at a height of 16' and 17'-8" above ground; a fiber splice box measuring 6 3/4" tall, 4 3/4" wide and 2 1/8" deep mounted on the pole at 3'-4".
Applicant /	Ana Gomez/Black & Veatch & Extenet (for: Verizon Wireless)
Phone Number:	(913) 458-9148
Owner:	City of Oakland
Case File Number:	PLN17-116
Planning Permits Required:	Major Conditional Use Permit and Design Review to install a wireless Monopole Telecommunications Facility on existing city light pole located in the public right -of- way in a residential zone.
General Plan:	Central Business District
Zoning:	CBD-R Central Business, Residential Zones.
Environmental Determination:	Exempt per Sections 15301 of the State CEQA Guidelines, minor additions and alterations to an existing city light pole; Section 15303, new construction or conversion of small structures; and Section 15183, projects consistent with a community plan, general plan or zoning.
Historic Status:	Non historic property
City Council District:	3
Date Filed:	April 29, 2017
Action to be Taken:	Decision based on staff report
Finality of Decision:	<i>Appealable to City Council within 10 days</i>
For Further Information:	Contact case planner Jason Madani, Planner II at (510) 238-4790 or jmadani@oaklandnet.com

SUMMARY

The project applicant (Extenet Systems) is proposing to install a wireless telecommunication facility on an existing 27' tall City street light pole located near 222 19th Street in the public right-of-way. The project involves installation of one (1) antenna measuring 24" long and 14.6" in diameter located within shroud at a height of 31'-2" and two radio units (12.05" wide and 27.17" tall and 7.01" deep) mounted at a height of 16' and 17'-8" above ground; a fiber splice box measuring 6 3/4" tall, 4 3/4" wide and 2 1/8" deep will be mounted on the pole at 3'-4" in height. The purpose of the installation is to enhance existing wireless services within downtown area. A Major Conditional Use Permit and Design Review is required for the installation of a new Monopole Telecommunications Facility in a residential zone. The antenna shroud and associated equipment will be painted green to match the City light pole. As result, the proposed telecommunication facility is an appropriate location and would not significantly increase negative visual impacts to adjacent neighboring properties. The project meets all the required findings for approval of the project.

CITY OF OAKLAND PLANNING COMMISSION

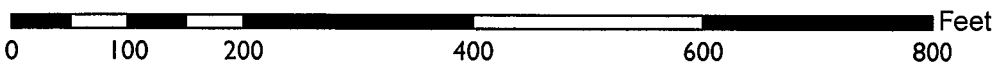
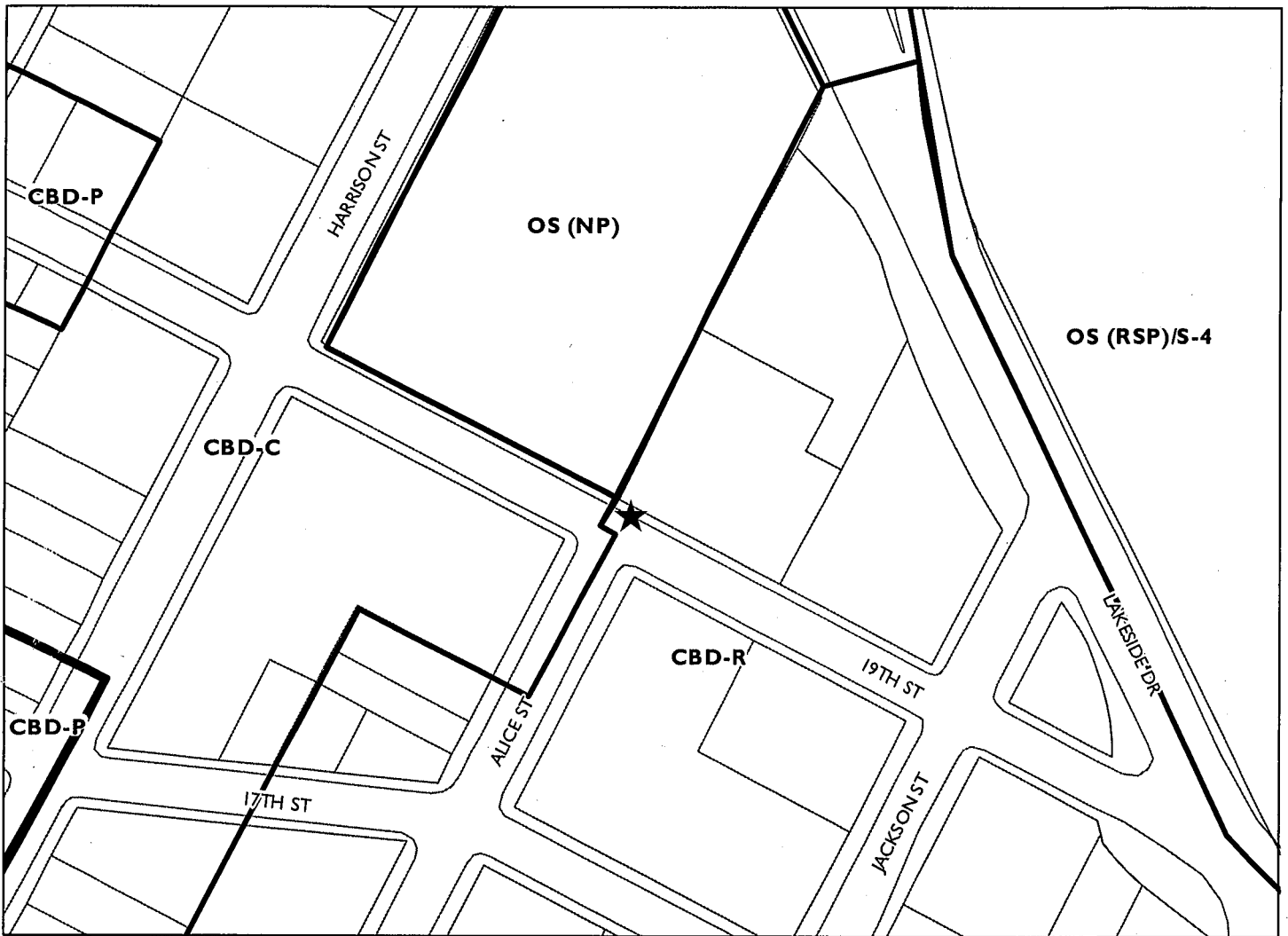

Case File: PLN17116

Applicant: Ana Gomez/Black & Veatch & Extenet (for: Verizon Wireless)

Address: The Public Right-of-Way near 222 19th Street

Zone: CBD-R

BACKGROUND

For several years in the City of Oakland, telecommunications carriers have proposed facility installations within the public right-of-way, instead of private property. These facilities typically consist of antennas and associated equipment attached to utility poles or street light poles. Poles are often replaced with replicas for technical purposes. The main purpose of the installation is to enhance existing service, given increasing technological demands for bandwidth, through new technology and locational advantages. The City exercises zoning jurisdiction over such projects in response to a 2009 State Supreme Court case decision (*Sprint v. Palos Verdes Estates*). Pursuant to the Planning Code, utility or joint pole authority (JPA) sites are classified by staff as "Macro Facilities," and street light pole sites (lamps, not traffic signals) as "Monopole Facilities." For JPA poles, only Design Review approval may be required, as opposed to Design Review and a Conditional Use Permit, for example. For non-JPA pole sites, such as City light poles, projects also require review by the City's Public Works Agency (PWA) and Real Estate Division, and involve other considerations such as impacts to historical poles. The PWA may also review projects involving street lights. In either case, the practice has been to refer all such projects to the Planning Commission for decision when located in or near a residential zone.

Several projects for new DAS (distributed antenna services) facilities have come before the Planning Commission for a decision and have been installed throughout the Oakland Hills. Some applications have been denied due to view obstructions or propinquity to residences. Improved practices for the processing of all types of sites incorporating Planning Commission direction have been developed as a result, with conditions of approval typically attached such as painting and texturing of approved components to more closely match utility poles in appearance. Approvals do not apply to any replacement project should the poles be removed for any reason. As with sites located on private property, the Federal Government precludes cities from denying an application on the basis of emissions concerns if a satisfactory emissions report is submitted. More recent Federal changes have streamlined the process to service existing facilities.

Currently, telecommunications carriers are in the process of attempting to deploy "small cell sites." These projects also involve attachment of antennas and equipment at public right-of-way facilities such as poles or lights for further enhancement of services. However, components are now somewhat smaller in size than in the past. Also, sites tend to be located in flat land neighborhoods and Downtown where view obstructions are less likely to be an issue. Good design and placement is given full consideration nonetheless, especially with the greater presence of historic structures in Downtown.

TELECOMMUNICATIONS BACKGROUND

Limitations on Local Government Zoning Authority under the Telecommunications Act of 1996

Section 704 of the Telecommunications Act of 1996 (TCA) provides federal standards for the siting of "Personal Wireless Services Facilities." "Personal Wireless Services" include all commercial mobile services (including personal communications services (PCS), cellular radio mobile services, and paging); unlicensed wireless services; and common carrier wireless exchange access services. Under Section 704, local zoning authority over personal wireless services is preserved such that the FCC is prevented from preempting local land use decisions; however, local government zoning decisions are still restricted by several provisions of federal law. Specifically:

- Under Section 253 of the TCA, no state or local regulation or other legal requirement can prohibit or have the effect of prohibiting the ability of any entity to provide any interstate or intrastate telecommunications service.
- Further, Section 704 of the TCA imposes limitations on what local and state governments can do. Section 704 prohibits any state and local government action which unreasonably discriminates among personal wireless providers. Local governments must ensure that its wireless ordinance does not

contain requirements in the form of regulatory terms or fees which may have the “effect” of prohibiting the placement, construction, or modification of personal wireless services.

- Section 704 also preempts any local zoning regulation purporting to regulate the placement, construction and modification of personal wireless service facilities on the basis, either directly or indirectly, on the environmental effects of radio frequency emissions (RF) of such facilities, which otherwise comply with Federal Communications Commission (FCC) standards in this regard. (See 47 U.S.C. Section 332(c)(7)(B)(iv) (1996)). This means that local authorities may not regulate the siting or construction of personal wireless facilities based on RF standards that are more stringent than those promulgated by the FCC.
- Section 704 mandates that local governments act upon personal wireless service facility siting applications to place, construct, or modify a facility within a reasonable time (See 47 U.S.C.332(c)(7)(B)(ii) and FCC Shot Clock ruling setting forth “reasonable time” standards for applications deemed complete).
- Section 704 also mandates that the FCC provide technical support to local governments in order to encourage them to make property, rights-of-way, and easements under their jurisdiction available for the placement of new spectrum-based telecommunications services. This proceeding is currently at the comment stage.

For more information on the FCC’s jurisdiction in this area, consult the following:

Competition & Infrastructure Policy Division (CIPD) of the Wireless Telecommunications Bureau, main division number: **(202) 418-1310**. <https://www.fcc.gov/general/competition-infrastructure-policy-division-wireless-telecommunications-bureau>

SITE DESCRIPTION

The project site consists of an existing non-decorative City street light pole located in the sidewalk near 222 19th Street, northeast of the intersection of Alice Street, adjacent to open space, a commercial mid-rise office building and residential building across street. The existing, metal, City street-light pole measures thirty (27) feet in height.

PROJECT DESCRIPTION

The proposal is to establish a Monopole Telecommunications Facility (“small cell site”) on an existing, street light pole located in the public right-of-way (Attachment A). The project involves installation of:

- One (1) antenna measuring 24” long and 14.6” in diameter located within shroud at a height of 31’-2”,
- Two (2) radio units (12.05” wide and 27.17” tall and 7.01” deep) mounted at a height of 16’ and 17’-8” above ground, and
- A fiber splice box measuring 6 3/4” tall, 4 3/4” wide and 2 1/8” deep mounted on the pole at 3’-4” in height.

GENERAL PLAN ANALYSIS

The site is located in the Central Business District (CBR) area under the General Plan’s Land Use and Transportation Element (LUTE). The intent of the area is to encourage, support, and enhance the downtown area as a high density mixed use urban center of regional importance and a primary hub for business,

communications, office, government, high technology, retail, entertainment, and transportation in Northern California.

Given increasing reliance upon cellular service for phone and internet, the proposal for a Monopole Telecommunications Facility will not adversely affect and detract from the characteristics of the neighborhood. Staff therefore finds the proposal, as conditioned, to conform to the General Plan.

ZONING ANALYSIS

The site is located in the CBD-R Central Business District Commercial Zone. “ The intent of CBD-R is to create, maintain, and enhance areas of the Central Business District appropriate for residential development with small-scaled compatible ground-level commercial uses. Monopole Telecommunications Facilities on City light poles require a Major Conditional Use Permit and a Regular Design Review with additional findings; these permits are decided by the Planning Commission for sites located within a residential zone. New wireless telecommunications facilities may also be subject to a Site Alternatives Analysis, Site Design Alternatives Analysis, and a satisfactory radio-frequency (RF) emissions report.

Staff analyzed the proposal in consideration of these requirements in the ‘Key Issues and Impacts’ section of this report. Additionally, attachment to City infrastructure requires review by the City’s Real Estate Department, Public Works Agency’s Electrical Division, and Information Technology Department. Given customers increasing reliance upon cellular service for phone and Wi-Fi, the proposal for a Monopole Telecommunications Facility that is not adjacent to the residential building (it is located across the street), therefore, the proposal conforms to this intent. Staff finds the proposal, as conditioned, to conform to the Planning Code.

ENVIRONMENTAL DETERMINATION

The California Environmental Quality Act (CEQA) Guidelines categorically exempts specific types of projects from environmental review. Section 15301 exempts projects involving ‘Existing Facilities’ and, Section 15303 exempts projects involving ‘Construction of Small Structures.’ The proposal fits all of these descriptions. The project is also subject to Section 15183 for ‘Projects consistent with a community plan, general plan or zoning.’ The project is, therefore, exempt from further Environmental Review.

KEY ISSUES AND IMPACTS

The proposal to establish a Monopole Telecommunications Facility is subject to the following Planning Code development standards, which are followed by staff’s analysis in relation to this application:

17.128.080 Monopole Telecommunications Facilities.

A. General Development Standards for Monopole Telecommunications Facilities.

1. Applicant and owner shall allow other future wireless communications companies including public and quasi-public agencies using similar technology to collocate antenna equipment and facilities on the monopole unless specific technical or other constraints, subject to independent verification, at the applicant's expense, at the discretion of the City of Oakland Zoning Manager, prohibit said collocation. Applicant and other wireless carriers shall provide a mechanism for the construction and maintenance of shared facilities and infrastructure and shall provide for equitable sharing of cost in

accordance with industry standards. Construction of future facilities shall not interrupt or interfere with the continuous operation of applicant's facilities.

The proposal involves use of an existing City street light pole that would remain available for future collocation purposes as practicable.

2. The equipment shelter or cabinet must be concealed from public view or made compatible with the architecture of the surrounding structures or placed underground. The shelter or cabinet must be regularly maintained.

Recommended conditions of approval require painting and texturing the antenna and equipment to match the appearance of the metal pole. There is no equipment shelter or cabinet proposed; however, minimal equipment (fiber splice box) would be closely mounted onto the side of the metal pole.

3. When a monopole is in a Residential Zone or adjacent to a residential use, it must be set back from the nearest residential lot line a distance at least equal to its total height.

The existing light pole is located within wide sidewalk adjacent to open space and is located across street from mid-rise office and residential buildings.

4. In all zones other than the D-CE-5, D-CE-6, IG, CIX-2, and IO Zones, the maximum height of Monopole Telecommunications Facilities and connecting appurtenances may be increased from the otherwise required maximum height to forty-five (45) feet upon the granting of a Conditional Use Permit (see Chapter 17.134 for the Conditional Use Permit Procedure).

This requirement does not apply. The subject property is not located in any of the described zoning districts. Nonetheless, the facility would not exceed the height of 31'-2".

5. In the D-CE-5, D-CE-6, CIX-2, and IO Zones, the maximum height of Monopole Telecommunications Facilities and connecting appurtenances may be increased from the otherwise required maximum height to eighty (80) feet upon the granting of a Conditional Use Permit (see Chapter 17.134 for the Conditional Use Permit Procedure).

This requirement does not apply. The subject property is not located in any of the described zoning districts. Nonetheless, the facility would not exceed the height of 31'-2".

6. In the IG Zone, the maximum height of Monopole Telecommunications Facilities and connecting appurtenances may reach a height of forty-five (45) feet. These facilities may reach a height of

eighty (80) feet upon the granting of Regular Design Review approval (see Chapter 17.136 for the Design Review Procedure).

This requirement does not apply. The subject property is not located in the described zoning district. Nonetheless, the facility would not exceed the height of 31'-2".

7. The applicant shall submit written documentation demonstrating that the emissions from the proposed project are within the limits set by the Federal Communications Commission.

This standard is met by the proposal; a satisfactory emissions report has been submitted and is attached to this report (Attachment B).

8. Antennas may not extend more than fifteen (15) feet above their supporting structure.

The proposed antenna would project less than fifteen feet above the City light pole.

17.128.110 Site location preferences.

New wireless facilities shall generally be located on the following properties or facilities in order of preference:

- A. Co-located on an existing structure or facility with existing wireless antennas.**
- B. City-owned properties or other public or quasi-public facilities.**
- C. Existing commercial or industrial structures in Nonresidential Zones (excluding all HBX Zones and the D-CE-3 and D-CE-4 Zones).**
- D. Existing commercial or industrial structures in Residential Zones, HBX Zones, or the DCE-3 or D-CE-4 Zones.**
- E. Other Nonresidential uses in Residential Zones, HBX Zones, or the D-CE-3 or D-CE-4 Zones.**
- F. Residential uses in Nonresidential Zones (excluding all HBX Zones and the D-CE-3 and D-CE-4 Zones).**
- G. Residential uses in Residential Zones, HBX Zones, or the D-CE-3 or D-CE-4 Zones.**

Facilities locating on an A, B or C ranked preference do not require a site alternatives analysis. Facilities proposing to locate on a D through G ranked preference, inclusive, must submit a site alternatives analysis as part of the required application materials. A site alternatives analysis shall, at a minimum, consist of:

- a. The identification of all A, B and C ranked preference sites within one thousand (1,000) feet of the proposed location. If more than three (3) sites in each preference order exist, the three such closest to the proposed location shall be required.
- b. Written evidence indicating why each such identified alternative cannot be used. Such evidence shall be in sufficient detail that independent verification, at the applicant's expense, could be obtained if required by the City of Oakland Zoning Manager. Evidence should indicate if the reason an alternative was rejected was technical (e.g. incorrect height, interference from existing

RF sources, inability to cover required area) or for other concerns (e.g. refusal to lease, inability to provide utilities).

A site alternatives analysis is not required because the proposal conforms to 'B' as it would be located on a public facility (City light pole). Nonetheless, the applicant has submitted an analysis which is attached to this report (Attachment C).

17.128.120 Site design preferences.

New wireless facilities shall generally be designed in the following order of preference:

- A. Building or structure mounted antennas completely concealed from view.**
- B. Building or structure mounted antennas set back from roof edge, not visible from public right-of way.**
- C. Building or structure mounted antennas below roof line (facade mount, pole mount) visible from public right-of-way, painted to match existing structure.**
- D. Building or structure mounted antennas above roof line visible from public right-of-way.**
- E. Monopoles.**
- F. Towers.**

Facilities designed to meet an A or B ranked preference do not require a site design alternatives analysis. Facilities designed to meet a C through F ranked preference, inclusive, must submit a site design alternatives analysis as part of the required application materials. A site design alternatives analysis shall, at a minimum, consist of:

- a. Written evidence indicating why each such higher preference design alternative cannot be used. Such evidence shall be in sufficient detail that independent verification could be obtained if required by the City of Oakland Zoning Manager. Evidence should indicate if the reason an alternative was rejected was technical (e.g. incorrect height, interference from existing RF sources, inability to cover required area) or for other concerns (e.g. inability to provide utilities, construction or structural impediments).

The proposal most closely conforms to 'E' (monopole), and the applicant has submitted a satisfactory site design alternatives analysis (Attachment C).

17.128.130 Radio frequency emissions standards.

The applicant for all wireless facilities, including requests for modifications to existing facilities, shall submit the following verifications:

- a. With the initial application, a RF emissions report, prepared by a licensed professional engineer or other expert, indicating that the proposed site will operate within the current acceptable

thresholds as established by the Federal government or any such agency who may be subsequently authorized to establish such standards.

b. Prior to commencement of construction, a RF emissions report indicating the baseline RF emissions condition at the proposed site.

c. Prior to final building permit sign off, an RF emissions report indicating that the site is actually operating within the acceptable thresholds as established by the Federal government or any such agency who may be subsequently authorized to establish such standards.

A satisfactory report is attached to this report (Attachment B).

Analysis

The proposed site design would not be situated on an historic or decorative pole or structure, would not create a view obstruction. Staff, therefore, finds the proposal to provide an essential service with a least-intrusive possible design. Draft conditions of approval stipulate that the components be painted and textured to match the metal pole in appearance for camouflaging.

Outreach

The applicant held a community meeting open to the public to introduce the technology in Downtown Oakland on February 24, 2017. The applicant also conducted additional outreach on April 10, 2017 in East Oakland. The applicant has relocated various proposed sites to accommodate neighbor and staff concerns.

CONCLUSION

The proposed project meets all the required findings for approval. The proposal will provide an essential telecommunication service to the community and the City of Oakland at large. It will also be available to emergency services such as police, fire department and emergency response teams. Staff believes that the proposal is designed to meet the established zoning and telecommunication regulations and recommends supporting the Major Conditional Use Permit and Design Review application.

- RECOMMENDATIONS:**
1. Affirm staff's environmental determination.
 2. Approve the Major Conditional Use Permit and Regular Design Review, subject to the attached Findings and Conditions of Approval.

Prepared by:



Jason Madani
Planner II

Approved by:



SCOTT MILLER
Zoning Manager

Approved for forwarding to the
City Planning Commission:



DARIN RANELLETTI, Interim Director
Department of Planning and Building

ATTACHMENTS:

- A. Project Plans & Photo simulations
- B. Hammett & Edison, Inc., Consulting Engineering RF Emissions Report
- C. Site & Design Alternative Analysis

ATTACHMENT A: FINDINGS

This proposal meets the required findings under General Use Permit Criteria (OMC Sec. 17.134.050), Conditional Use Permit Criteria for Monopole Facilities (OMC Sec. 17.136.040 (A)), Regular Design Review Criteria for Nonresidential Facilities (OMC Sec. 17.136.050(B)), Design Review Criteria for Monopole Telecommunications Facilities (OMC Sec. 17.128.070(B)), as set forth below. Required findings are shown in bold type; explanations as to why these findings can be made are in normal type.

GENERAL USE PERMIT CRITERIA (OMC SEC. 17.134.050):

A. That the location, size, design, and operating characteristics of the proposed development will be compatible with and will not adversely affect the livability or appropriate development of abutting properties and the surrounding neighborhood, with consideration to be given to harmony in scale, bulk, coverage, and density; to the availability of civic facilities and utilities; to harmful effect, if any, upon desirable neighborhood character; to the generation of traffic and the capacity of surrounding streets; and to any other relevant impact of the development.

The proposal is to establish a Monopole Telecommunications Facility in the Central Business District Residential Zone by attaching an antenna and related equipment to an existing City light pole. Attachment to an existing structure with smallest possible components, painted and texturized to match the light pole, will be the least intrusive design. The project will enhance existing service for merchants, shoppers, residents, and visitors in the area.

B. That the location, design, and site planning of the proposed development will provide a convenient and functional living, working, shopping, or civic environment, and will be as attractive as the nature of the use and its location and setting warrant.

Attachment of a telecommunication facility to an existing City light pole structure with smallest possible components, painted and texturized, to match the pole will be the least intrusive design.

C. That the proposed development will enhance the successful operation of the surrounding area in its basic community functions, or will provide an essential service to the community or region.

The project will enhance existing service for merchants, shoppers, residents, and visitors in the area.

D. That the proposal conforms to all applicable design review criteria set forth in the design review procedure at Section 17.136.070.

The proposal conforms to Design Review findings which are included below..

E. That the proposal conforms in all significant respects with the Oakland Comprehensive Plan and with any other applicable plan or development control map which has been adopted by the City Council.

The site is located in the Central Business District (CBD) land use classification per the Land Use and Transportation Element (LUTE) of the General Plan. The intent of this classification is to encourage, support, and enhance the downtown area as a high density mixed use urban center of regional importance and a primary hub for business, communications, office, government, high technology, retail, entertainment, and transportation in Northern California. Given increasing reliance upon cellular service for phone and internet, the proposal for a Monopole Telecommunications Facility will not adversely affect

and detract from the characteristics of the neighborhood. Staff, therefore, finds the proposal, as conditioned, to conform to the General Plan and the specifically, the following policies

Civic and Institutional Uses, Objective N2: Encourage adequate civic, institutional, and educational facilities located within Oakland, appropriately designed and sited to serve the community.

Infrastructure, Objective N12: Provide adequate infrastructure to meet the needs of Oakland's growing community.

CONDITIONAL USE PERMIT CRITERIA FOR MONOPOLE FACILITIES (OMC SEC. 17.128.070(C))

1. The project must meet the special design review criteria listed in subsection B of this section.

The proposal conforms to the Design Review findings below.

2. Monopoles should not be located any closer than one thousand five hundred (1,500) feet from existing monopoles unless technologically required or visually preferable.

Use of this pole precludes of existing light pole with facility viewable from the commercial buildings and is therefore "visually preferable."

3. The proposed project must not disrupt the overall community character.

Attachment to an existing structure with smallest possible components, painted and texturized, to match the pole will be the least intrusive design. The project will enhance existing service for merchants, shoppers, residents, and visitors in the area.

4. If a major conditional use permit is required, the Planning Director or the Planning Commission may request independent expert review regarding site location, collocation and facility configuration. Any party may request that the Planning Commission consider making such request for independent expert review.

a. If there is any objection to the appointment of an independent expert engineer, the applicant must notify the Planning Director within ten (10) days of the Commission request. The Commission will hear arguments regarding the need for the independent expert and the applicant's objection to having one appointed. The Commission will rule as to whether an independent expert should be appointed.

b. Should the Commission appoint an independent expert, the Commission will direct the Planning Director to pick an expert from a panel of licensed engineers, a list of which will be compiled, updated and maintained by the Planning Department.

c. No expert on the panel will be allowed to review any materials or investigate any application without first signing an agreement under penalty of perjury that the expert will keep confidential

any and all information learned during the investigation of the application. No personnel currently employed by a telecommunication company are eligible for inclusion on the list.

d. An applicant may elect to keep confidential any proprietary information during the expert's investigation. However, if an applicant does so elect to keep confidential various items of proprietary information, that applicant may not introduce the confidential proprietary information for the first time before the Commission in support of the application.

e. The Commission shall require that the independent expert prepare the report in a timely fashion so that it will be available to the public prior to any public hearing on the application.

f. Should the Commission appoint an independent expert, the expert's fees will be paid by the applicant through the application fee, imposed by the City.

A Major Conditional Use Permit is required and the Planning Director or Planning Commission may, therefore, require independent expert review in addition to that which is attached to this report.

REGULAR DESIGN REVIEW CRITERIA FOR NON-RESIDENTIAL FACILITIES (OMC SEC. 17.136.050(B))

1. That the proposed design will create a building or set of buildings that are well related to the surrounding area in their setting, scale, bulk, height, materials, and textures:

Attachment to an existing structure with smallest possible components, painted and texturized, to match the pole will be the least intrusive design. The proposed telecommunication facility, located on the City street light, provides enough separation from both commercial buildings and the residential building located across street; therefore, the proposal will not have a significant view impact to the adjacent neighboring properties in this area.

2. That the proposed design will protect, preserve, or enhance desirable neighborhood characteristics;

The proposed telecommunication, located on the City street light, provides enough separation from both commercial buildings and the residential building located across the street and will not be located on an historic or decorative structure; therefore, the proposal will not significant view impact to the adjacent neighboring properties in this area.

3. The project will provide a necessary function without negatively impacting surrounding opens pace and hillside residential properties.

The proposal will enhance essential services in an urbanized neighborhood.

4. That the proposed design will be sensitive to the topography and landscape.

The proposal will not be ground mounted.

5. That, if situated on a hill, the design and massing of the proposed building relates to the grade of the hill.

This finding is inapplicable because the site is level.

6. That the proposed design conforms in all significant respects with the Oakland General Plan and with any applicable design review guidelines or criteria, district plan, or development control map which have been adopted by the Planning Commission or City Council.

The site is located in the Central Business District (CBD) land use classification per the Land Use and Transportation Element (LUTE) of the General Plan. The intent of the classification is to encourage, support, and enhance the downtown area as a high density mixed use urban center of regional importance and a primary hub for business, communications, office, government, high technology, retail, entertainment, and transportation in Northern California. Given increasing reliance upon cellular service for phone and internet, the proposal for a Monopole Telecommunications Facility will not adversely affect and detract from the characteristics of the neighborhood. Staff, therefore, finds the proposal, as conditioned, to conform to the General Plan.

**DESIGN REVIEW CRITERIA FOR MONOPOLE TELECOMMUNICATIONS FACILITIES
(OMC SEC. 17.128.070(B))**

1. Collocation is to be encouraged when it will decrease visual impact and collocation is to be discouraged when it will increase negative visual impact.

The project does not involve collocation as it involves the establishment of a new telecommunications facility; however, the project should not preclude any future proposals for location at the site.

2. Monopoles should not be sited to create visual clutter or negatively affect specific views.

The Monopole Facility is sited on existing infrastructure where it will not create clutter or negatively affect specific views. The view of the City street light from the adjacent residential building located across the street and the open space area will be minimal.

3. Monopoles shall be screened from the public view wherever possible.

The Monopole Facility will be camouflaged and texturized to match the appearance of the existing light pole that will host it.

4. The equipment shelter or cabinet must be concealed from public view or made compatible with the architecture of the surrounding structures or placed underground. The shelter or cabinet must be regularly maintained.

Recommended conditions of approval require painting and texturing the antenna and equipment to match the appearance of the metal pole. There is no equipment shelter or cabinet proposed; however minimal equipment would be closely mounted on the side of the metal pole.

5. Site location and development shall preserve the preexisting character of the surrounding buildings and land uses and the zone district as much as possible. Wireless communication towers shall be integrated through location and design to blend in with the existing characteristics of the site to the extent practical. Existing on-site vegetation shall be preserved or improved, and disturbance of the

existing topography shall be minimized, unless such disturbance would result in less visual impact of the site to the surrounding area.

The proposed Monopole Facility will be placed on an existing non-decorative City light pole. This enables the preservation of character in the area. The facility will not pose a negative visual impact as the proposal will be camouflaged to match the pole. There is no adjacent vegetation or topography.

6. That all reasonable means of reducing public access to the antennas and equipment has been made, including, but not limited to, placement in or on buildings or structures, fencing, anti-climbing measures and anti-tampering devices.

The minimal clearance to the facility will measure approximately 16' in height.

Attachment B: Conditions of Approval

1. Approved Use

The project shall be constructed and operated in accordance with the authorized use as described in the approved application materials, **staff report** and the approved plans **dated March 14, 2017 and submitted April 29, 2017**, as amended by the following conditions of approval and mitigation measures, if applicable (“Conditions of Approval” or “Conditions”).

2. Effective Date, Expiration, Extensions and Extinguishment

This Approval shall become effective immediately, unless the Approval is appealable, in which case the Approval shall become effective in ten calendar days unless an appeal is filed. Unless a different termination date is prescribed, this Approval shall expire **two calendar years** from the Approval date, or from the date of the final decision in the event of an appeal, unless within such period all necessary permits for construction or alteration have been issued, or the authorized activities have commenced in the case of a permit not involving construction or alteration. Upon written request and payment of appropriate fees submitted no later than the expiration date of this Approval, the Director of City Planning or designee may grant a one-year extension of this date, with additional extensions subject to approval by the approving body. Expiration of any necessary building permit or other construction-related permit for this project may invalidate this Approval if said Approval has also expired. If litigation is filed challenging this Approval, or its implementation, then the time period stated above for obtaining necessary permits for construction or alteration and/or commencement of authorized activities is automatically extended for the duration of the litigation.

3. Compliance with Other Requirements

The project applicant shall comply with all other applicable federal, state, regional, and local laws/codes, requirements, regulations, and guidelines, including but not limited to those imposed by the City’s Bureau of Building, Fire Marshal, and Public Works Department. Compliance with other applicable requirements may require changes to the approved use and/or plans. These changes shall be processed in accordance with the procedures contained in Condition #4.

4. Minor and Major Changes

- a. Minor changes to the approved project, plans, Conditions, facilities, or use may be approved administratively by the Director of City Planning.
- b. Major changes to the approved project, plans, Conditions, facilities, or use shall be reviewed by the Director of City Planning to determine whether such changes require submittal and approval of a revision to the Approval by the original approving body or a new independent permit/approval. Major revisions shall be reviewed in accordance with the procedures required for the original permit/approval. A new independent permit/approval shall be reviewed in accordance with the procedures required for the new permit/approval.

5. Compliance with Conditions of Approval

- a. The project applicant and property owner, including successors, (collectively referred to hereafter as the “project applicant” or “applicant”) shall be responsible for compliance with all the Conditions of Approval and any recommendations contained in any submitted and approved

technical report at his/her sole cost and expense, subject to review and approval by the City of Oakland.

- b. The City of Oakland reserves the right at any time during construction to require certification by a licensed professional at the project applicant's expense that the as-built project conforms to all applicable requirements, including but not limited to, approved maximum heights and minimum setbacks. Failure to construct the project in accordance with the Approval may result in remedial reconstruction, permit revocation, permit modification, stop work, permit suspension, or other corrective action.
- c. Violation of any term, Condition, or project description relating to the Approval is unlawful, prohibited, and a violation of the Oakland Municipal Code. The City of Oakland reserves the right to initiate civil and/or criminal enforcement and/or abatement proceedings, or after notice and public hearing, to revoke the Approval or alter these Conditions if it is found that there is violation of any of the Conditions or the provisions of the Planning Code or Municipal Code, or the project operates as or causes a public nuisance. This provision is not intended to, nor does it, limit in any manner whatsoever the ability of the City to take appropriate enforcement actions. The project applicant shall be responsible for paying fees in accordance with the City's Master Fee Schedule for inspections conducted by the City or a City-designated third-party to investigate alleged violations of the Approval or Conditions.

6. Signed Copy of the Approval/Conditions

A copy of the Approval letter and Conditions shall be signed by the project applicant, attached to each set of permit plans submitted to the appropriate City agency for the project, and made available for review at the project job site at all times.

7. Blight/Nuisances

The project site shall be kept in a blight/nuisance-free condition. Any existing blight or nuisance shall be abated within 60 days of approval, unless an earlier date is specified elsewhere.

8. Indemnification

- a. To the maximum extent permitted by law, the project applicant shall defend (with counsel acceptable to the City), indemnify, and hold harmless the City of Oakland, the Oakland City Council, the Oakland Redevelopment Successor Agency, the Oakland City Planning Commission, and their respective agents, officers, employees, and volunteers (hereafter collectively called "City") from any liability, damages, claim, judgment, loss (direct or indirect), action, causes of action, or proceeding (including legal costs, attorneys' fees, expert witness or consultant fees, City Attorney or staff time, expenses or costs) (collectively called "Action") against the City to attack, set aside, void or annul this Approval or implementation of this Approval. The City may elect, in its sole discretion, to participate in the defense of said Action and the project applicant shall reimburse the City for its reasonable legal costs and attorneys' fees.
- b. Within ten (10) calendar days of the filing of any Action as specified in subsection (a) above, the project applicant shall execute a Joint Defense Letter of Agreement with the City, acceptable to the Office of the City Attorney, which memorializes the above obligations. These obligations and the Joint Defense Letter of Agreement shall survive termination, extinguishment, or invalidation of the Approval. Failure to timely execute the Letter of Agreement does not relieve the project

applicant of any of the obligations contained in this Condition or other requirements or Conditions of Approval that may be imposed by the City.

9. Severability

The Approval would not have been granted but for the applicability and validity of each and every one of the specified Conditions, and if one or more of such Conditions is found to be invalid by a court of competent jurisdiction this Approval would not have been granted without requiring other valid Conditions consistent with achieving the same purpose and intent of such Approval.

10. Job Site Plans

Ongoing throughout demolition, grading, and/or construction

At least one (1) copy of the stamped approved plans, along with the Approval Letter and Conditions of Approval, shall be available for review at the job site at all times.

11. Special Inspector/Inspections, Independent Technical Review, Project Coordination and Monitoring

The project applicant may be required to cover the full costs of independent third-party technical review and City monitoring and inspection, including without limitation, special inspector(s)/inspection(s) during times of extensive or specialized plan-check review or construction, and inspections of potential violations of the Conditions of Approval. The project applicant shall establish a deposit with the Bureau of Building, if directed by the Building Official, Director of City Planning, or designee, prior to the issuance of a construction-related permit and on an ongoing as-needed basis.

12. Public Improvements

The project applicant shall obtain all necessary permits/approvals, such as encroachment permits, obstruction permits, curb/gutter/sidewalk permits, and public improvement (“p-job”) permits from the City for work in the public right-of-way, including but not limited to, streets, curbs, gutters, sidewalks, utilities, and fire hydrants. Prior to any work in the public right-of-way, the applicant shall submit plans for review and approval by the Bureau of Planning, the Bureau of Building, and other City departments as required. Public improvements shall be designed and installed to the satisfaction of the City.

13. Construction Days/Hours

Requirement: The project applicant shall comply with the following restrictions concerning construction days and hours:

- a. Construction activities are limited to between 7:00 a.m. and 7:00 p.m. Monday through Friday, except that pier drilling and/or other extreme noise generating activities greater than 90 dBA shall be limited to between 8:00 a.m. and 4:00 p.m.
- b. Construction activities are limited to between 9:00 a.m. and 5:00 p.m. on Saturday. In residential zones and within 300 feet of a residential zone, construction activities are allowed from 9:00 a.m.

to 5:00 p.m. only within the interior of the building with the doors and windows closed. No pier drilling or other extreme noise generating activities greater than 90 dBA are allowed on Saturday.

c. No construction is allowed on Sunday or federal holidays.

Construction activities include, but are not limited to, truck idling, moving equipment (including trucks, elevators, etc.) or materials, deliveries, and construction meetings held on-site in a non-enclosed area.

Any construction activity proposed outside of the above days and hours for special activities (such as concrete pouring which may require more continuous amounts of time) shall be evaluated on a case-by-case basis by the City, with criteria including the urgency/emergency nature of the work, the proximity of residential or other sensitive uses, and a consideration of nearby residents'/occupants' preferences. The project applicant shall notify property owners and occupants located within 300 feet at least 14 calendar days prior to construction activity proposed outside of the above days/hours. When submitting a request to the City to allow construction activity outside of the above days/hours, the project applicant shall submit information concerning the type and duration of proposed construction activity and the draft public notice for City review and approval prior to distribution of the public notice.

When Required: During construction

Initial Approval: N/A

Monitoring/Inspection: Bureau of Building

PROJECT-SPECIFIC CONDITIONS

14. Emissions Report

Requirement: A RF emissions report shall be submitted to the Planning Bureau indicating that the site is actually operating within the acceptable thresholds as established by the Federal government or any such agency who may be subsequently authorized to establish such standards.

Requirement: Prior to a final inspection

When Required: Prior to final building permit inspection sign-off

Initial Approval: N/A

Monitoring/Inspection: N/A

15. Camouflage

Requirement: The antenna and equipment shall be painted, texturized, and maintained the same color and finish of the City light pole.

When Required: Prior to a final inspection

Initial Approval: N/A

Monitoring/Inspection: Bureau of Building

16. Operational

Requirement: Noise levels from the activity, property, or any mechanical equipment on site shall comply with the performance standards of Section 17.120 of the Oakland Planning Code and Section 8.18 of the Oakland Municipal Code. If noise levels exceed these standards, the activity causing the

noise shall be abated until appropriate noise reduction measures have been installed and compliance verified by the Planning and Zoning Division and Building Services.

When Required: Ongoing

Initial Approval: N/A

Monitoring/Inspection: Bureau of Building

17. Possible District Undergrounding PG&E Pole

Requirement: Should the City light pole be permanently removed for purposes of district undergrounding or otherwise, the telecommunications facility can only be re-established by applying for and receiving approval of a new application to the Oakland Planning Bureau as required by the regulations.

When Required: Ongoing

Initial Approval: N/A

Monitoring/Inspection: N/A

18. Graffiti Control

Requirement:

- a. During construction and operation of the project, the project applicant shall incorporate best management practices reasonably related to the control of graffiti and/or the mitigation of the impacts of graffiti. Such best management practices may include, without limitation:
 - a. The project applicant shall remove graffiti by appropriate means within seventy-two (72) hours. Appropriate means include the following:
 - i. Removal through scrubbing, washing, sanding, and/or scraping (or similar method) without damaging the surface and without discharging wash water or cleaning detergents into the City storm drain system.
 - ii. For galvanized poles, covering with new paint to match the color of the surrounding surface.
 - iii. Replace pole numbers.

When Required: Ongoing

Initial Approval: N/A

Monitoring/Inspection: Bureau of Building

NW-CA-DTOAKLAN 00014A

ADJACENT TO (IN PROW)
222 19TH STREET
OAKLAND, CA 94612

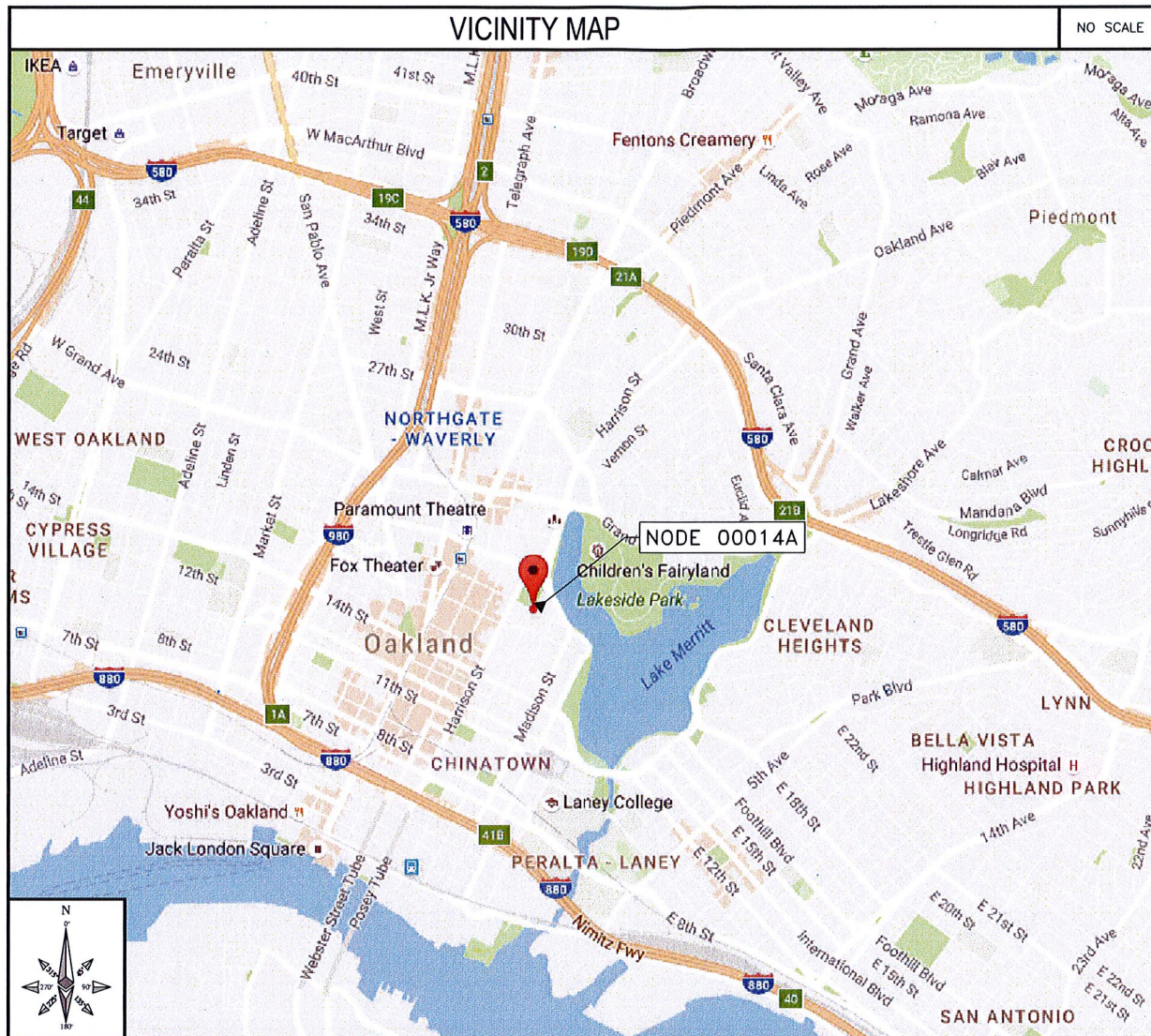
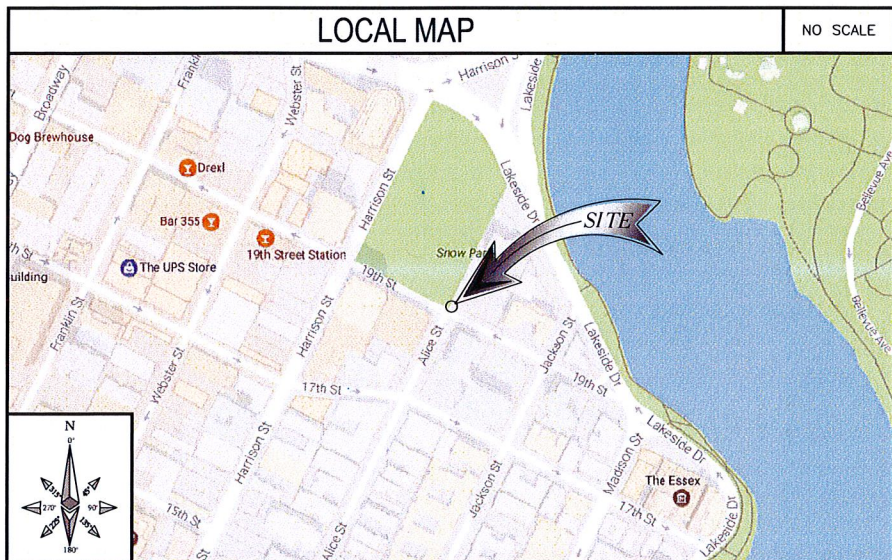

CODE COMPLIANCE

ALL WORK AND MATERIALS SHALL BE PERFORMED AND INSTALLED IN ACCORDANCE WITH THE CURRENT EDITIONS OF THE FOLLOWING CODES AS ADOPTED BY THE LOCAL GOVERNING AUTHORITIES (AS APPLICABLE). NOTHING IN THESE PLANS IS TO BE CONSTRUCTED TO PERMIT WORK NOT CONFORMING TO THESE CODES.

- 1: IBC - 2012
- 2: CALIFORNIA BUILDING STANDARDS CODE - 2013
- 3: CALIFORNIA GENERAL ORDER 95
- 4: CALIFORNIA MECHANICAL CODE 2013
- 5: CALIFORNIA PLUMBING CODE 2013
- 6: CALIFORNIA ELECTRICAL CODE 2013
- 7: CITY AND/OR COUNTY ORDINANCES
- 8: 2012 INTERNATIONAL FIRE CODE
- 9: BUILDING OFFICIALS AND CODE ADMINISTRATORS (BOCA)
*EFFECTIVE UNTIL JANUARY 1ST, 2017

PROJECT DESCRIPTION

THESE DRAWINGS DEPICT THE INSTALLATION OF A WIRELESS TELECOMMUNICATIONS NODE IN THE PUBLIC RIGHT OF WAY.

HARDWARE AND ANCILLARY EQUIPMENT TO BE INSTALLED AS DESCRIBED HEREIN.

GENERAL PROJECT NOTES

1. PRIOR TO SUBMITTING A BID, THE CONTRACTOR SHALL FAMILIARIZE HIMSELF/HERSELF WITH THE SCOPE OF WORK AND ALL CONDITIONS AFFECTING THE NEW PROJECT.
2. CONTRACTOR SHALL VERIFY ALL FIELD CONDITIONS AND DIMENSIONS OF THE JOB SITE AND CONFIRM THAT WORK AS INDICATED ON THESE CONSTRUCTION DOCUMENTS CAN BE ACCOMPLISHED AS SHOWN PRIOR TO COMMENCEMENT OF ANY WORK.
3. ALL FIELD MODIFICATIONS BEFORE, DURING OR AFTER CONSTRUCTION SHALL BE APPROVED IN WRITING BY AN EXTENET SYSTEMS REPRESENTATIVE.
4. INSTALL ALL EQUIPMENT AND MATERIALS PER THE MANUFACTURER'S RECOMMENDATIONS, UNLESS INDICATED OTHERWISE.
5. NOTIFY EXTENET SYSTEMS, IN WRITING, OF ANY MAJOR DISCREPANCIES REGARDING THE CONTRACT DOCUMENTS, EXISTING CONDITIONS, AND DESIGN INTENT. THE CONTRACTOR SHALL BE RESPONSIBLE FOR OBTAINING CLARIFICATIONS FROM AN EXTENET SYSTEMS REPRESENTATIVE, AND ADJUSTING THE BID ACCORDINGLY.
6. CONTRACTOR SHALL BE SOLELY RESPONSIBLE FOR ALL CONSTRUCTION MEANS, METHODS, TECHNIQUES, SEQUENCES AND PROCEDURES OF THE WORK UNDER THE CONTRACT.
7. CONTRACTOR SHALL PROTECT ALL EXISTING IMPROVEMENTS AND FINISHES THAT ARE TO REMAIN. CONTRACTOR SHALL REPAIR ANY DAMAGE THAT MAY OCCUR DURING THE CONSTRUCTION TO THE SATISFACTION OF AN EXTENET SYSTEMS REPRESENTATIVE.
8. CONTRACTOR PLANS TO ILLUSTRATE THE AS-BUILT CONDITION OF THE SITE. FOLLOWING THE FINAL INSPECTION BY EXTENET OR CLIENT, THE CONTRACTOR SHALL PROVIDE EXTENET SYSTEMS WITH ONE COPY OF ALL RED-LINED DRAWINGS.
9. VERIFY ALL FINAL EQUIPMENT WITH AN EXTENET SYSTEMS REPRESENTATIVE. ALL EQUIPMENT LAYOUT, SPECS, PERFORMANCE INSTALLATION AND THEIR FINAL LOCATION ARE TO BE APPROVED BY EXTENET SYSTEMS. THE CONTRACTOR SHALL BE RESPONSIBLE FOR COORDINATING HIS/HER WORK WITH THE WORK AND CLEARANCES REQUIRED BY OTHERS RELATED TO SAID INSTALLATIONS.

INTERNAL REVIEW

CONSTRUCTION SIGNATURE	DATE
RF SIGNATURE	DATE
REAL ESTATE SIGNATURE	DATE

BLACK & VEATCH CORPORATION
2999 OAK ROAD
SUITE 490
WALNUT CREEK, CA 94597

THESE DRAWINGS ARE COPYRIGHTED AND ARE THE PROPERTY OF BLACK & VEATCH; PRODUCED SOLELY FOR THE USE OF OUR CLIENT. ANY REPRODUCTION OR USE OF THE INFORMATION CONTAINED WITHIN SAID DRAWINGS IS PROHIBITED WITHOUT WRITTEN CONSENT BY BLACK & VEATCH.

PROJECT NO.	DRAWN BY	CHECKED BY
192417.5561	LEW	LW

REV	DATE	DESCRIPTION
B	03/14/17	ISSUED FOR REVIEW
A	03/06/17	ISSUED FOR REVIEW

PRELIMINARY

IT IS A VIOLATION OF LAW FOR ANY PERSON, UNLESS THEY ARE ACTING UNDER THE DIRECTION OF A LICENSED PROFESSIONAL ENGINEER, TO ALTER THIS DOCUMENT.

EXTENET SYSTEMS (CA) LLC
2000 CROW CANYON PLACE
SUITE 210
SAN RAMON, CA 94583

SITE ADDRESS
ADJACENT TO (IN PROW)
222 19TH ST
OAKLAND, CA 94612

SHEET TITLE
TITLE SHEET

SHEET NUMBER
T-1

SHEET INDEX

SHEET NO:	SHEET TITLE
T-1	TITLE SHEET
GN-1	GENERAL NOTES AND LEGEND
C-1	OVERALL SITE PLAN
C-2	UTILITY POLE ELEVATIONS
C-2.1	RISER DETAILS
C-3	EQUIPMENT DETAILS
C-4	EQUIPMENT DETAILS
C-5	CONCEPTUAL WIRING DIAGRAMS

PROJECT INFORMATION

POLE OWNER	APPLICANT
OWNER: CITY OF OAKLAND ADDRESS: 7101 EDGEWATER DRIVE OAKLAND, CA 94621 PHONE: -	COMPANY: EXTENET SYSTEMS CALIFORNIA, LLC. CONTACT: MATTHEW YERGOVICH ADDRESS: 2000 CROW CANYON PLACE, SUITE 210 SAN RAMON, CA 94583 PHONE: (415) 596-3474 E-MAIL: MYERGOVICH@EXTENETSYSTEMS.COM

AGENT	ENGINEER	PROJECT DATA
COMPANY: BLACK & VEATCH CONTACT: ANA GOMEZ ADDRESS: 2999 OAK ROAD, SUITE 490 WALNUT CREEK, CA 94597 PHONE: (913) 458-9148 E-MAIL: GOMEZABARCAA@BV.COM	COMPANY: BLACK & VEATCH ENGINEER: AARON EVANS PHONE: (952) 896-0751 E-MAIL: EVANSRA@BV.COM	LATITUDE: 37.8059656 LONGITUDE: -122.26422 POLE #: A6341 ELEVATION: XXX' AMSL ZONING JURISDICTION: CITY OF OAKLAND ZONING DISTRICT: CBD-R NEAREST A.P.N.: 008-063400300 OCCUPANCY: U, UNMANNED CONSTRUCTION TYPE: ATTACHMENTS TO A METAL/STREET LIGHT POLE TITLE 24 REQUIREMENTS: FACILITY IS UNMANNED AND NOT FOR HUMAN HABITATION. THIS PROJECT IS EXEMPT.

IF USING 11"X17" PLOT, DRAWINGS WILL BE HALF SCALE

SUBCONTRACTOR SHALL VERIFY ALL PLANS & EXISTING DIMENSIONS & CONDITIONS ON THE JOB SITE & SHALL IMMEDIATELY NOTIFY THE ENGINEER IN WRITING OF ANY DISCREPANCIES BEFORE PROCEEDING WITH THE WORK OR BE RESPONSIBLE FOR SAME

UNDERGROUND SERVICE ALERT
UTILITIES PROTECTION CENTER, INC.
811
48 HOURS BEFORE YOU DIG

GENERAL NOTES

- THESE NOTES SHALL BE CONSIDERED A PART OF THE WRITTEN SPECIFICATIONS, CONTRACT AND CONSTRUCTION DOCUMENTS.
- THE WORK SHALL INCLUDE FURNISHING MATERIALS, EQUIPMENT, APPURTENANCES, AND LABOR NECESSARY TO COMPLETE ALL INSTALLATIONS AS INDICATED ON THESE PLANS AND IN THE CONTRACT DOCUMENTS.
- PRIOR TO THE SUBMISSION OF BIDS, THE CONTRACTOR(S) SHALL VISIT THE JOB SITE(S) AND BE RESPONSIBLE FOR ALL CONTRACT DOCUMENTS, FIELD CONDITIONS AND DIMENSIONS, AND CONFIRM THAT THE WORK MAY BE ACCOMPLISHED PER THE CONTRACT DOCUMENTS. ANY DISCREPANCIES ARE TO BE BROUGHT TO THE ATTENTION OF THE IMPLEMENTATION ENGINEER AND ARCHITECT/ENGINEER PRIOR TO BID SUBMITTAL.
- THE CONTRACTOR SHALL RECEIVE WRITTEN AUTHORIZATION TO PROCEED ON ANY WORK NOT CLEARLY DEFINED OR IDENTIFIED IN THE CONTRACT AND CONSTRUCTION DOCUMENTS BEFORE STARTING ANY WORK.
- ALL WORK PERFORMED AND MATERIALS INSTALLED SHALL BE IN STRICT ACCORDANCE WITH ALL APPLICABLE CODES, REGULATIONS, AND ORDINANCES, INCLUDING APPLICABLE MUNICIPAL AND UTILITY COMPANY SPECIFICATIONS.
- THE CONTRACTOR SHALL INSTALL ALL EQUIPMENT AND MATERIALS IN ACCORDANCE WITH MANUFACTURER RECOMMENDATIONS. IF THESE RECOMMENDATIONS ARE IN CONFLICT WITH THE CONTRACT AND CONSTRUCTION DOCUMENTS AND/OR APPLICABLE CODES OR REGULATIONS, REVIEW AND RESOLVE THE CONFLICT WITH DIRECTION FROM THE IMPLEMENTATION ENGINEER AND ARCHITECT/ENGINEER PRIOR TO PROCEEDING.
- THE CONTRACTOR SHALL BE SOLELY RESPONSIBLE FOR ALL CONSTRUCTION MEANS, METHODS, TECHNIQUES, SEQUENCES, AND PROCEDURES AND FOR COORDINATION OF ALL PORTIONS OF THE WORK UNDER THE CONTRACT INCLUDING CONTACT AND COORDINATION WITH THE IMPLEMENTATION ENGINEER AND WITH THE AUTHORIZED REPRESENTATIVE OF ANY OUTSIDE POLE OR PROPERTY OWNER.
- THE CONTRACTOR SHALL MAKE NECESSARY PROVISIONS TO PROTECT EXISTING IMPROVEMENTS, INCLUDING BUT NOT LIMITED TO PAVING, CURBS, VEGETATION, GALVANIZED SURFACE OR OTHER EXISTING ELEMENTS AND UPON COMPLETION OF THE WORK, REPAIR ANY DAMAGE THAT OCCURRED DURING CONSTRUCTION TO THE SATISFACTION OF EXTENET.
- CONTRACTOR IS TO KEEP THE GENERAL AREA CLEAN, HAZARD FREE, AND DISPOSE OF ALL DIRT, DEBRIS, RUBBISH, AND REMOVE EQUIPMENT NOT SPECIFIED AS REMAINING ON THE PROPERTY. LEAVE PREMISES IN CLEAN CONDITION DAILY.
- PLANS ARE INTENDED TO BE DIAGRAMMATIC ONLY AND SHOULD NOT BE SCALED UNLESS OTHERWISE NOTED. RELY ONLY ON ANNOTATED DIMENSIONS AND REQUEST INFORMATION IF ADDITIONAL DIMENSIONS ARE REQUIRED.
- THE EXISTENCE AND LOCATION OF UTILITIES AND OTHER AGENCY'S FACILITIES WERE OBTAINED BY A SEARCH OF AVAILABLE RECORDS. OTHER FACILITIES MAY EXIST. CONTRACTOR SHALL VERIFY LOCATIONS PRIOR TO START OF CONSTRUCTION AND USE EXTREME CARE AND PROTECTIVE MEASURES TO PREVENT DAMAGE TO THESE FACILITIES. CONTRACTOR IS RESPONSIBLE FOR THE PROTECTION OF UTILITIES OR OTHER AGENCY'S FACILITIES WITHIN THE LIMITS OF THE WORK. WHETHER THEY ARE IDENTIFIED IN THE CONTRACT DOCUMENTS OR NOT.
- THE CONTRACTOR SHALL NOTIFY UNDERGROUND SERVICE ALERT (800) 227-2600, AT LEAST TWO WORKING DAYS PRIOR TO THE START OF ANY EXCAVATION.

DEFINITIONS

- "TYPICAL" OR "TYP" MEANS THAT THIS ITEM IS SUBSTANTIALLY THE SAME ACROSS SIMILAR CONDITIONS. "TYP." SHALL BE UNDERSTOOD TO MEAN "TYPICAL WHERE OCCURS" AND SHALL NOT BE CONSIDERED AS WITHOUT EXCEPTION OR CONSIDERATION OF SPECIFIC CONDITIONS.
- "SIMILAR" MEANS COMPARABLE TO CHARACTERISTICS FOR THE CONDITION NOTED. VERIFY DIMENSIONS AND ORIENTATION ON PLAN.
- "AS REQUIRED" MEANS AS REQUIRED BY REGULATORY REQUIREMENTS, BY REFERENCED STANDARDS, BY EXISTING CONDITIONS, BY GENERALLY ACCEPTED CONSTRUCTION PRACTICE, OR BY THE CONTRACT DOCUMENTS.
- "ALIGN" MEANS ACCURATELY LOCATE FINISH FACES OF MATERIALS IN THE SAME PLANE.
- THE TERM "VERIFY" OR "V.I.F." SHALL BE UNDERSTOOD TO MEAN "VERIFY IN FIELD WITH ENGINEER" AND REQUIRES THAT THE CONTRACTOR CONFIRM INTENTION REGARDING NOTED CONDITION AND PROCEED ONLY AFTER RECEIVING DIRECTION.
- WHERE THE WORDS "OR EQUAL" OR WORDS OF SIMILAR INTENT FOLLOW A MATERIAL SPECIFICATION, THEY SHALL BE UNDERSTOOD TO REQUIRE SIGNED APPROVAL OF ANY DEVIATION TO SAID SPECIFICATION PRIOR TO CONTRACTOR'S ORDERING OR INSTALLATION OF SUCH PROPOSED EQUAL PRODUCT.
- FURNISH : SUPPLY ONLY, OTHERS TO INSTALL. INSTALL: INSTALL ITEMS FURNISHED BY OTHERS, PROVIDE: FURNISH AND INSTALL.

FIELD WELDING NOTES:

- WELDING TO BE PERFORMED BY AWS CERTIFIED WELDER FOR THE TYPE OF AND POSITION INDICATED. ALL WORK MUST BE IN CONFORMANCE WITH LATEST EDITION OF AWS D1.1.
- GRIND SURFACES TO BE WELDED WITH A SILICON CARBIDE WHEEL PRIOR TO WELDING TO REMOVE ALL GALVANIZING WHICH MAY OTHERWISE BE CONSUMED IN THE WELD METAL. APPLY ANTI-SPATTER COMPOUND AFTER GRINDING.
- WELDING TECHNIQUE MUST MINIMIZE TEMPERATURE RISE ON THE INSIDE SURFACE OF THE POLE AND ALSO VOLATIZE ANY REMAINING ZINC WITHIN THE BASE METAL WITH MINIMUM SPATTER, USE AN E70 (LOW HYDROGEN) ELECTRODE. USE LARGEST DIAMETER ELECTRODE COMPATIBLE WITH WELDING POSITION AND MATERIAL THICKNESS. STRICTLY FOLLOW ALL MANUFACTURE'S INSTRUCTIONS FOR STORAGE AND USE OF ELECTRODES. AVOID REMOVING ELECTRODES FROM MANUFACTURE'S PACKAGING UNTIL READY FOR IMMEDIATE USE.
- WELDING MAY PRODUCE TOXIC FUMES. REFER TO ANSI STANDARD Z49.1 "SAFETY IN WELDING AND CUTTING" FOR PROPER PRECAUTIONS.
- UPON COMPLETION OF WELDING, APPLY GALV-A-STICK ZINC COATING TO ALL UNPROTECTED SURFACES. APPLY A SECOND LAYER OF COLD GALVANIZING SPRAY COMPOUND CONTAINING A MINIMUM ZINC CONTENT OF 95%. IF NECESSARY, APPLY A FINAL COAT OF COMPATIBLE PAINT TO MATCH SURROUNDING SURFACES.

ANTENNA MOUNTING

- DESIGN AND CONSTRUCTION OF ANTENNA SUPPORTS SHALL CONFORM TO CURRENT ANSI/TIA-222 OR APPLICABLE LOCAL CODES.
- ALL STEEL MATERIALS SHALL BE GALVANIZED AFTER FABRICATION IN ACCORDANCE WITH ASTM A123 "ZINC (HOT-DIP GALVANIZED) COATINGS ON IRON AND STEEL PRODUCTS", UNLESS NOTED OTHERWISE.
- ALL BOLTS, ANCHORS AND MISCELLANEOUS HARDWARE SHALL BE GALVANIZED IN ACCORDANCE WITH ASTM A153 "ZINC-COATING (HOT-DIP) ON IRON AND STEEL HARDWARE", UNLESS NOTED OTHERWISE.
- DAMAGED GALVANIZED SURFACES SHALL BE REPAIRED BY COLD GALVANIZING IN ACCORDANCE WITH ASTM A780.
- ALL ANTENNA MOUNTS SHALL BE INSTALLED WITH LOCK NUTS, DOUBLE NUTS AND SHALL BE TORQUED TO MANUFACTURER'S RECOMMENDATIONS.
- CONTRACTOR SHALL INSTALL ANTENNA PER MANUFACTURER'S RECOMMENDATION FOR INSTALLATION AND GROUNDING.
- PRIOR TO SETTING ANTENNA AZIMUTHS AND DOWNTILTS, ANTENNA CONTRACTOR SHALL CHECK THE ANTENNA MOUNT FOR TIGHTNESS AND ENSURE THAT THEY ARE PLUMB. ANTENNA AZIMUTHS SHALL BE SET FROM TRUE NORTH AND BE ORIENTED WITHIN +/- 5% AS DEFINED BY THE RFDS. ANTENNA DOWNTILTS SHALL BE WITHIN +/- 0.5% AS DEFINED BY THE RFDS.

TORQUE REQUIREMENTS

- ALL RF CONNECTIONS SHALL BE TIGHTENED BY A TORQUE WRENCH.
- ALL RF CONNECTIONS, GROUNDING HARDWARE AND ANTENNA HARDWARE SHALL HAVE A TORQUE MARK INSTALLED IN A CONTINUOUS STRAIGHT LINE FROM BOTH SIDES OF THE CONNECTION.
 - RF CONNECTION BOTH SIDES OF THE CONNECTOR.
 - GROUNDING AND ANTENNA HARDWARE ON THE NUT SIDE STARTING FROM THE THREADS TO THE SOLID SURFACE. EXAMPLE OF SOLID SURFACE: GROUND BAR, ANTENNA BRACKET METAL.
- ALL 8M ANTENNA HARDWARE SHALL BE TIGHTENED TO 9 LB-FT (12 NM).
- ALL 12M ANTENNA HARDWARE SHALL BE TIGHTENED TO 43 LB-FT (58 NM).
- ALL GROUNDING HARDWARE SHALL BE TIGHTENED UNTIL THE LOCK WASHER COLLAPSES AND THE GROUNDING HARDWARE IS NO LONGER LOOSE.
- ALL DIN TYPE CONNECTIONS SHALL BE TIGHTENED TO 18-22 LB-FT (24.4 - 29.8 NM).
- ALL N TYPE CONNECTIONS SHALL BE TIGHTENED TO 15-20 LB-IN (1.7 - 2.3 NM).

ROW UTILITY POLE CONSTRUCTION NOTES

- NO BOLT THREADS TO PROTRUDE MORE THAN 1-1/2" [.038M].
- FILL ALL HOLES LEFT IN POLE FROM REARRANGEMENT OF CLIMBERS.
- ALL CLIMB STEPS NEXT TO CONDUIT SHALL HAVE EXTENDED STEPS.
- CABLE NOT TO IMPEDE 15" [.381M] CLEAR SPACE OFF POLE FACE (12:00).
- 90 SHORT SWEEPS UNDER ANTENNA ARM. ALL CABLES MUST ONLY TRANSITION ON THE INSIDE OR BOTTOM OF ARMS (NO CABLE ON TOP OF ARMS).
- USE 90 CONNECTOR AT CABLE CONNECTION TO ANTENNAS.
- USE 1/2" [.013M] CABLE ON ANTENNAS UNLESS OTHERWISE SPECIFIED.
- FILL VOID AROUND CABLES AT CONDUIT OPENING WITH FOAM SEALANT TO PREVENT WATER INTRUSION.

NODE SITE POWER SHUT DOWN PROCEDURES

- FOR NON EMERGENCY/SCHEDULED POWER SHUT DOWN
 - CALL EXTENET SYSTEMS NOC (NETWORK OPERATIONS CENTER) (866)892-5327
 - 24 HOURS PRIOR TO SCHEDULED POWER SHUT OFF
 - PROVIDE THE FOLLOWING INFORMATION
 - NOC SITE NUMBER IDENTIFIED ON SITE NUMBERING STICKER
 - YOUR NAME AND REASON FOR POWER SHUTOFF
 - PROVIDE DURATION OF OUTAGE
 - UNLOCK DISCONNECT BOX, FLIP BOTH BREAKERS TO THE OFF POSITION
 - POWER SHUT OFF VERIFICATION WITH APPROVED PG&E PROCEDURES
 - NOTIFY EXTENET NOC UPON COMPLETION OF WORK
 - REINSTALL LOCK ON DISCONNECT BOX
- EMERGENCY POWER SHUT OFF
 - CALL EXTENET SYSTEMS NOC (NETWORK OPERATIONS CENTER) (866)892-5327
 - PROVIDE THE FOLLOWING INFORMATION
 - NOC SITE NUMBER IDENTIFIED ON SITE NUMBERING STICKER
 - YOUR NAME AND REASON FOR POWER SHUTOFF
 - PROVIDE DURATION OF OUTAGE
 - UNLOCK DISCONNECT BOX, FLIP BOTH BREAKERS TO THE OFF POSITION
 - POWER SHUT OFF VERIFICATION WITH APPROVED PG&E PROCEDURES
 - NOTIFY EXTENET NOC UPON COMPLETION OF WORK
 - REINSTALL LOCK ON DISCONNECT BOX

LEGEND

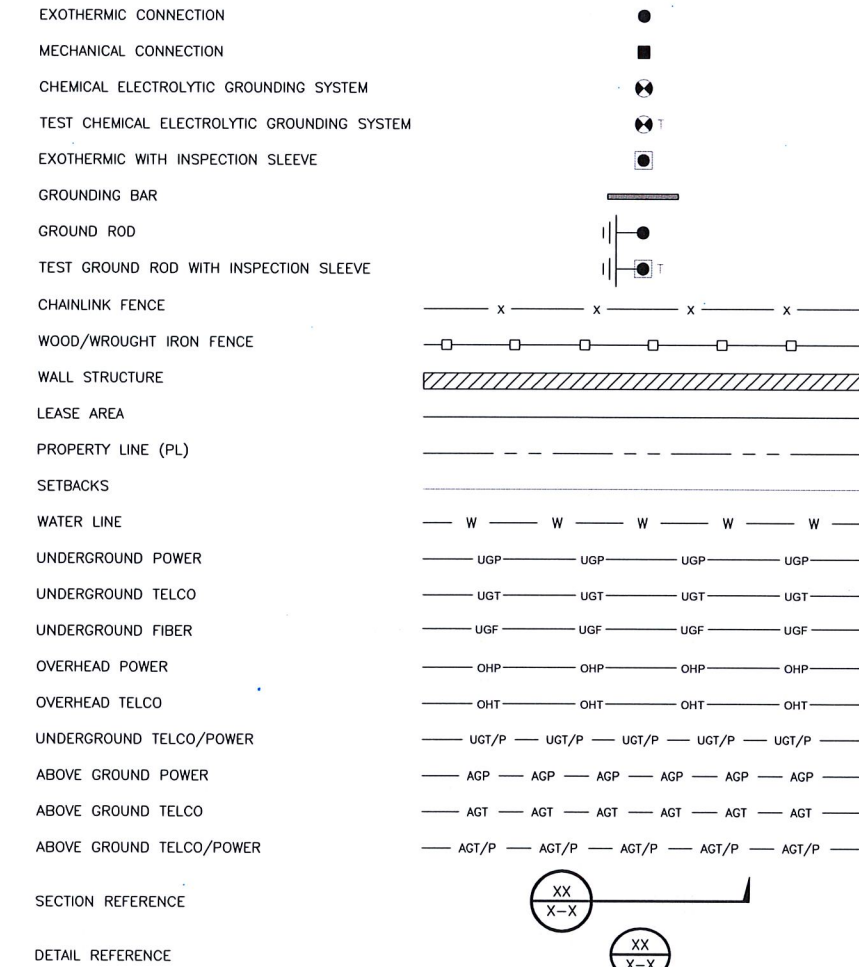

INTERNAL REVIEW	
CONSTRUCTION SIGNATURE	DATE
RF SIGNATURE	DATE
REAL ESTATE SIGNATURE	DATE

BLACK & VEATCH CORPORATION
2999 OAK ROAD
SUITE 490
WALNUT CREEK, CA 94597

THESE DRAWINGS ARE COPYRIGHTED AND ARE THE PROPERTY OF BLACK & VEATCH; PRODUCED SOLELY FOR THE USE OF OUR CLIENT. ANY REPRODUCTION OR USE OF THE INFORMATION CONTAINED WITHIN SAID DRAWINGS IS PROHIBITED WITHOUT WRITTEN CONSENT BY BLACK & VEATCH.

PROJECT NO.	DRAWN BY	CHECKED BY
192417.5561	LEW	LW

REV	DATE	DESCRIPTION
B	03/14/17	ISSUED FOR REVIEW
A	03/06/17	ISSUED FOR REVIEW

PRELIMINARY

IT IS A VIOLATION OF LAW FOR ANY PERSON, UNLESS THEY ARE ACTING UNDER THE DIRECTION OF A LICENSED PROFESSIONAL ENGINEER, TO ALTER THIS DOCUMENT.

EXTENET SYSTEMS (CA) LLC
2000 CROW CANYON PLACE
SUITE 210
SAN RAMON, CA 94583

SITE ADDRESS
ADJACENT TO (IN PROW)
222 19TH ST
OAKLAND, CA 94612

SHEET TITLE
GENERAL NOTES
AND LEGEND

SHEET NUMBER
GN-1

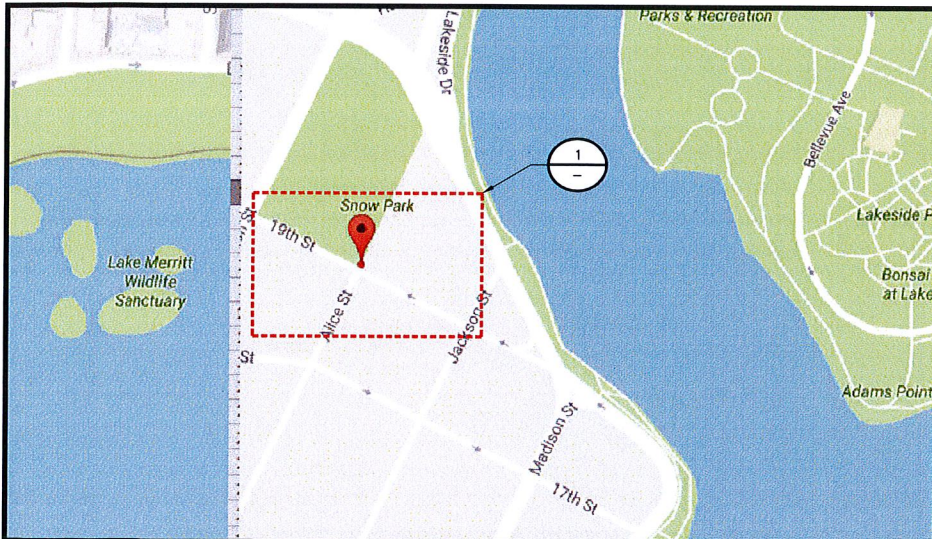

SITE PLAN MAP

NO SCALE

A

THIS DRAWING IS NOT A SITE SURVEY
 THE PURPOSE OF THIS DRAWING IS TO SHOW HOW THE DEVELOPED SITE RELATES TO THE PARENT PARCEL AND ADJACENT PROPERTIES. R.O.W. MEASUREMENTS ARE APPROXIMATIONS.

- NOTES**
1. EXTENET TO UTILIZE EXISTING CITY OF OAKLAND STREETLIGHT ELECTRICAL DUCT STRUCTURE TO NEAREST COMMERCIAL POWER CONNECTION POINT
 - OR
 2. EXTENET TO BRING COMMERCIAL POWER AND FIBER OPTIC CABLE TO CITY OF OAKLAND STREETLIGHT ELECTRICAL BOX SERVING SPECIFIED EXISTING CITY OF OAKLAND STREETLIGHT AND UTILIZE EXISTING CONDUIT CONNECTION BETWEEN THE ELECTRIC BOX AND STREETLIGHT

SNOW MUSEUM PARK
 A.P.N. 008-063500100

222 19th STREET
 A.P.N. 008-063400300

1800 HARRISON ST
 A.P.N. 008-062600101

1850 ALICE STREET
 A.P.N. 008-062703803

NEAREST EXISTING STRUCTURE
 (COMMERCIAL BUILDING)

NODE 00014A

B
 AZIMUTH
 295°

A
 AZIMUTH
 115°

16'-1"

74'-8"

EXISTING MUNICIPAL HANDHOLE

EXISTING TREE (TYP)

EXISTING RIGHT-OF-WAY

EXISTING CENTERLINE OF ROAD (TYP)

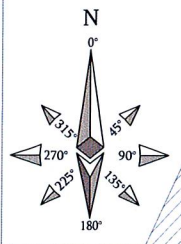

OVERALL SITE PLAN

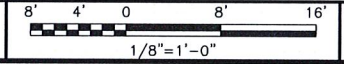

INTERNAL REVIEW	
CONSTRUCTION SIGNATURE	DATE
RF SIGNATURE	DATE
REAL ESTATE SIGNATURE	DATE

BLACK & VEATCH CORPORATION
 2999 OAK ROAD
 SUITE 490
 WALNUT CREEK, CA 94597

THESE DRAWINGS ARE COPYRIGHTED AND ARE THE PROPERTY OF BLACK & VEATCH; PRODUCED SOLELY FOR THE USE OF OUR CLIENT. ANY REPRODUCTION OR USE OF THE INFORMATION CONTAINED WITHIN SAID DRAWINGS IS PROHIBITED WITHOUT WRITTEN CONSENT BY BLACK & VEATCH.

PROJECT NO.	DRAWN BY	CHECKED BY
192417.5561	LEW	LW

REV	DATE	DESCRIPTION
B	03/14/17	ISSUED FOR REVIEW
A	03/06/17	ISSUED FOR REVIEW

PRELIMINARY

IT IS A VIOLATION OF LAW FOR ANY PERSON, UNLESS THEY ARE ACTING UNDER THE DIRECTION OF A LICENSED PROFESSIONAL ENGINEER, TO ALTER THIS DOCUMENT.

EXTENET SYSTEMS (CA) LLC
 2000 CROW CANYON PLACE
 SUITE 210
 SAN RAMON, CA 94583

SITE ADDRESS
 ADJACENT TO (IN PROW)
 222 19TH ST
 OAKLAND, CA 94612

SHEET TITLE
 OVERALL SITE PLAN

SHEET NUMBER
C-1

NOTE

THESE DRAWINGS HAVE BEEN CREATED BASED ON THE ASSUMPTION THAT THE STRUCTURE HAS SUFFICIENT CAPACITY TO SUPPORT THE PROPOSED LOADING. IT IS THE RESPONSIBILITY OF THE POLE OWNER TO CONFIRM THAT THE PROPOSED LOADING IS WITHIN THE ORIGINAL DESIGN CAPACITY OF THE STRUCTURE.

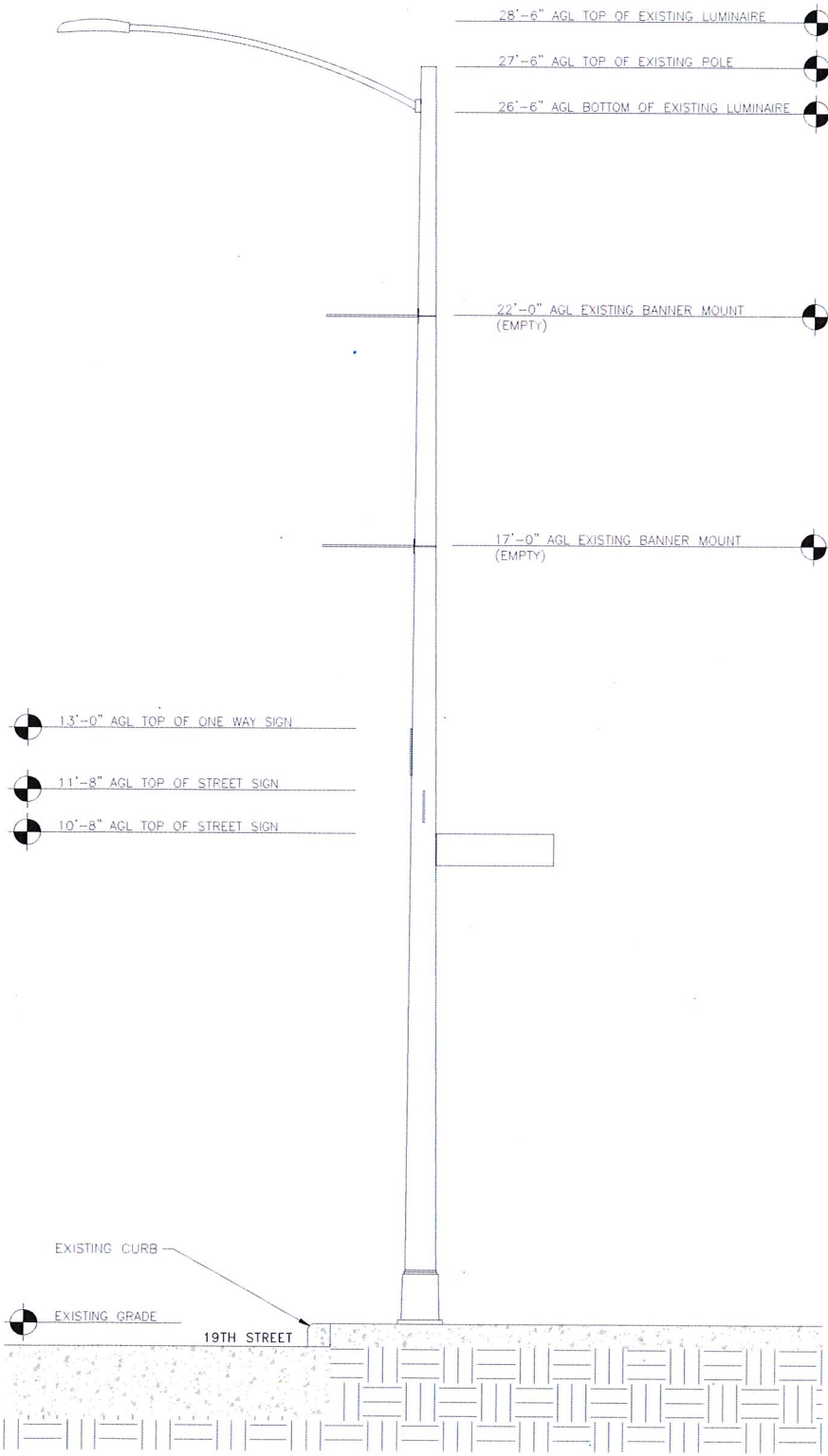

EXISTING EAST ELEVATION

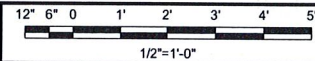

A

NOTES

1. ALL PROPOSED EQUIPMENT TO BE PAINTED TO MATCH EXISTING CONDITIONS.
2. DISTANCE FROM ANTENNA FACE TO NEAREST BUILDING (1850 ALICE ST). SEE SHEET C-1 FOR ORIENTATION.

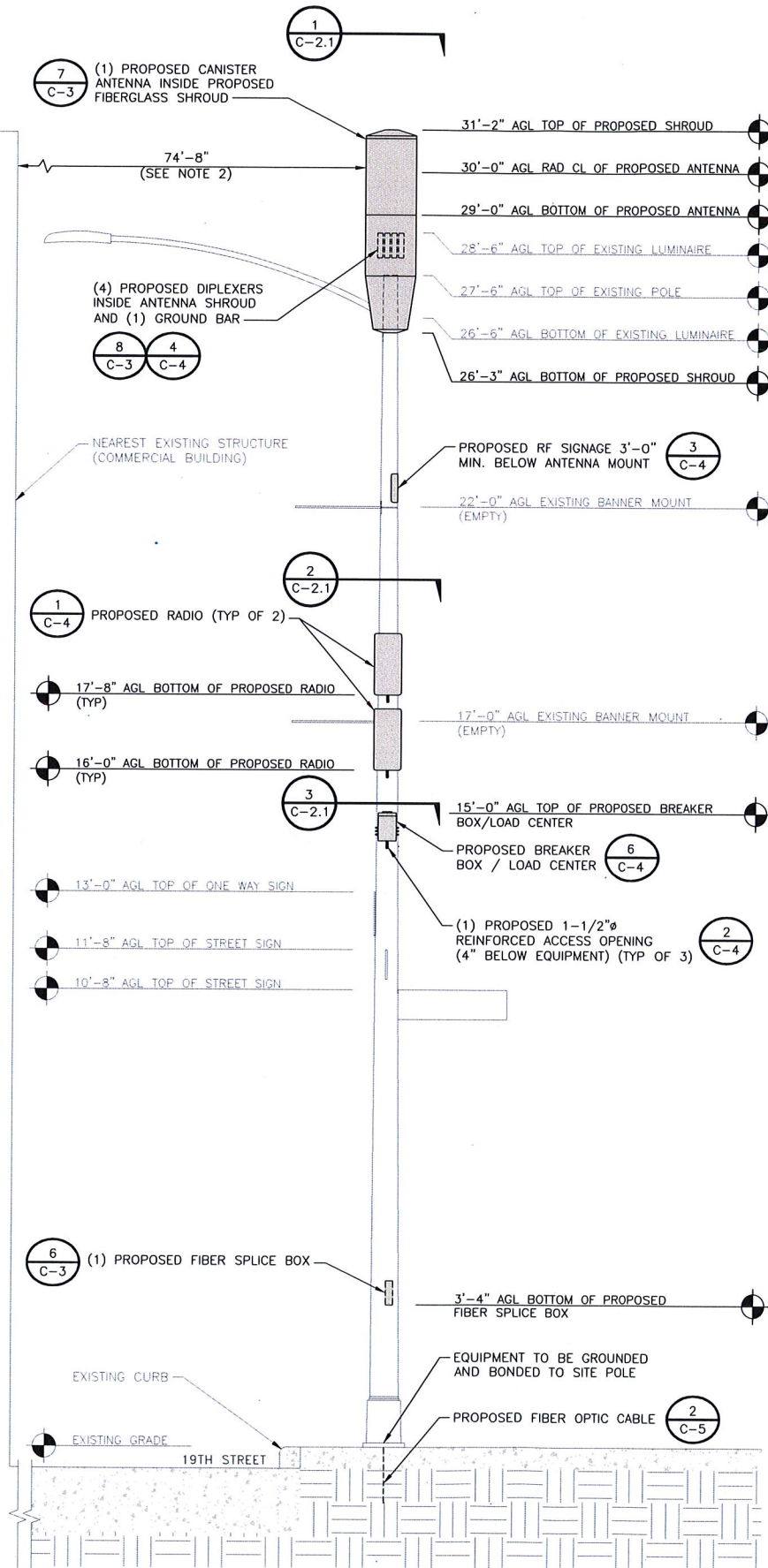

PROPOSED EAST ELEVATION

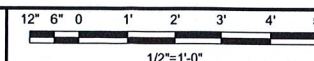

B

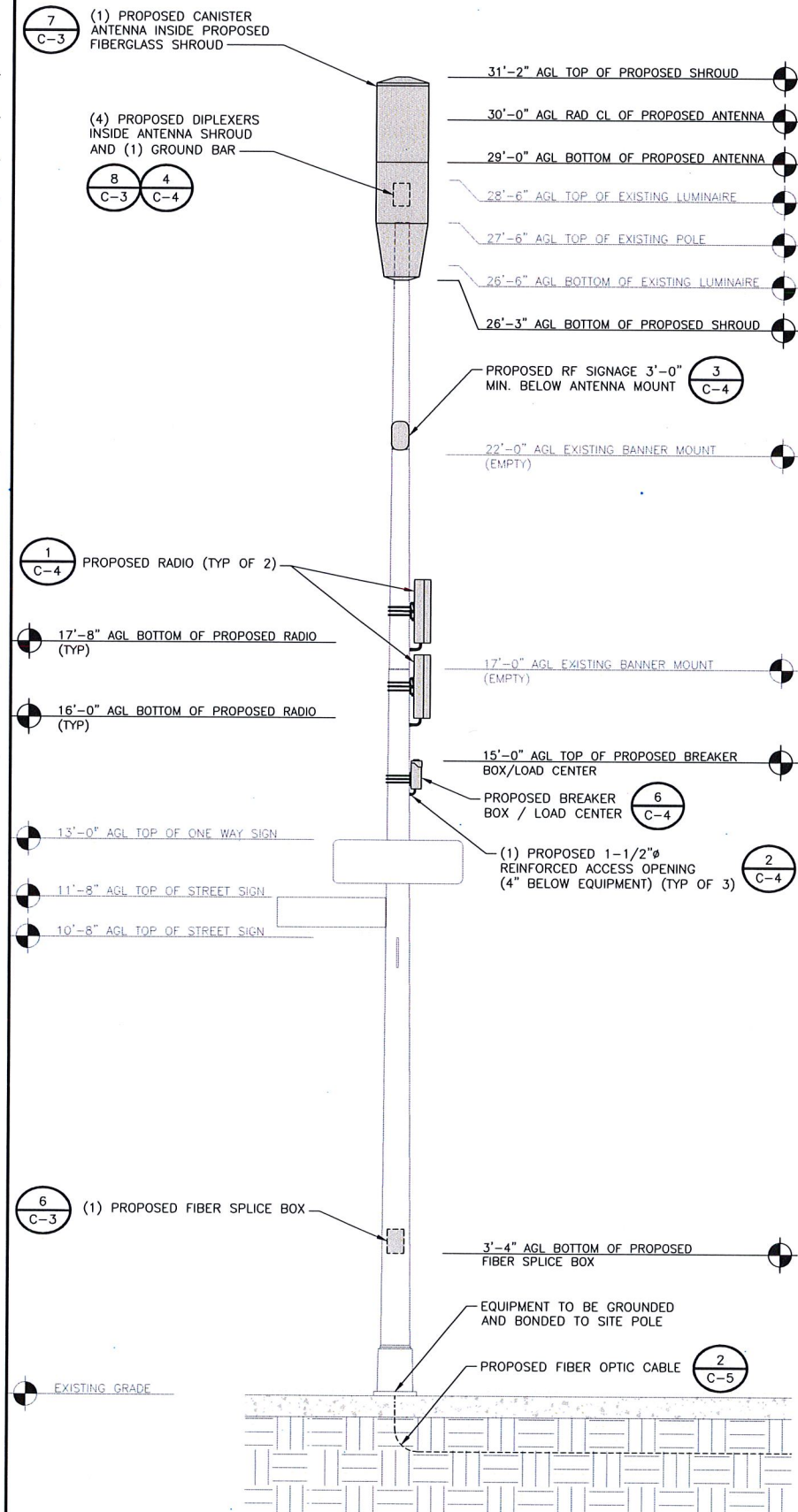

PROPOSED NORTH ELEVATION

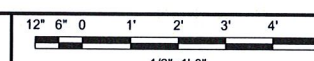

C



INTERNAL REVIEW	
CONSTRUCTION SIGNATURE	DATE
RF SIGNATURE	DATE
REAL ESTATE SIGNATURE	DATE



BLACK & VEATCH

BLACK & VEATCH CORPORATION
2999 OAK ROAD
SUITE 490
WALNUT CREEK, CA 94597

THESE DRAWINGS ARE COPYRIGHTED AND ARE THE PROPERTY OF BLACK & VEATCH; PRODUCED SOLELY FOR THE USE OF OUR CLIENT. ANY REPRODUCTION OR USE OF THE INFORMATION CONTAINED WITHIN SAID DRAWINGS IS PROHIBITED WITHOUT WRITTEN CONSENT BY BLACK & VEATCH.

PROJECT NO.	DRAWN BY	CHECKED BY
192417.5561	LEW	LW

REV	DATE	DESCRIPTION
B	03/14/17	ISSUED FOR REVIEW
A	03/06/17	ISSUED FOR REVIEW

PRELIMINARY

IT IS A VIOLATION OF LAW FOR ANY PERSON, UNLESS THEY ARE ACTING UNDER THE DIRECTION OF A LICENSED PROFESSIONAL ENGINEER, TO ALTER THIS DOCUMENT.

EXTENET SYSTEMS (CA) LLC
2000 CROW CANYON PLACE
SUITE 210
SAN RAMON, CA 94583

SITE ADDRESS
ADJACENT TO (IN PROW)
222 19TH ST
OAKLAND, CA 94612

SHEET TITLE
UTILITY POLE ELEVATIONS

SHEET NUMBER
C-2

INTERNAL REVIEW	
CONSTRUCTION SIGNATURE	DATE
RF SIGNATURE	DATE
REAL ESTATE SIGNATURE	DATE

BLACK & VEATCH

BLACK & VEATCH CORPORATION
2999 OAK ROAD
SUITE 490
WALNUT CREEK, CA 94597

THESE DRAWINGS ARE COPYRIGHTED AND ARE THE PROPERTY OF BLACK & VEATCH; PRODUCED SOLELY FOR THE USE OF OUR CLIENT. ANY REPRODUCTION OR USE OF THE INFORMATION CONTAINED WITHIN SAID DRAWINGS IS PROHIBITED WITHOUT WRITTEN CONSENT BY BLACK & VEATCH.

PROJECT NO.	DRAWN BY	CHECKED BY
192417.5561	LEW	LW

REV	DATE	DESCRIPTION
B	03/14/17	ISSUED FOR REVIEW
A	03/06/17	ISSUED FOR REVIEW

PRELIMINARY

IT IS A VIOLATION OF LAW FOR ANY PERSON, UNLESS THEY ARE ACTING UNDER THE DIRECTION OF A LICENSED PROFESSIONAL ENGINEER, TO ALTER THIS DOCUMENT.

EXTENET SYSTEMS (CA) LLC
2000 CROW CANYON PLACE
SUITE 210
SAN RAMON, CA 94583

SITE ADDRESS
ADJACENT TO (IN PROW)
222 19TH ST
OAKLAND, CA 94612

SHEET TITLE
RISER DETAILS

SHEET NUMBER
C-2.1

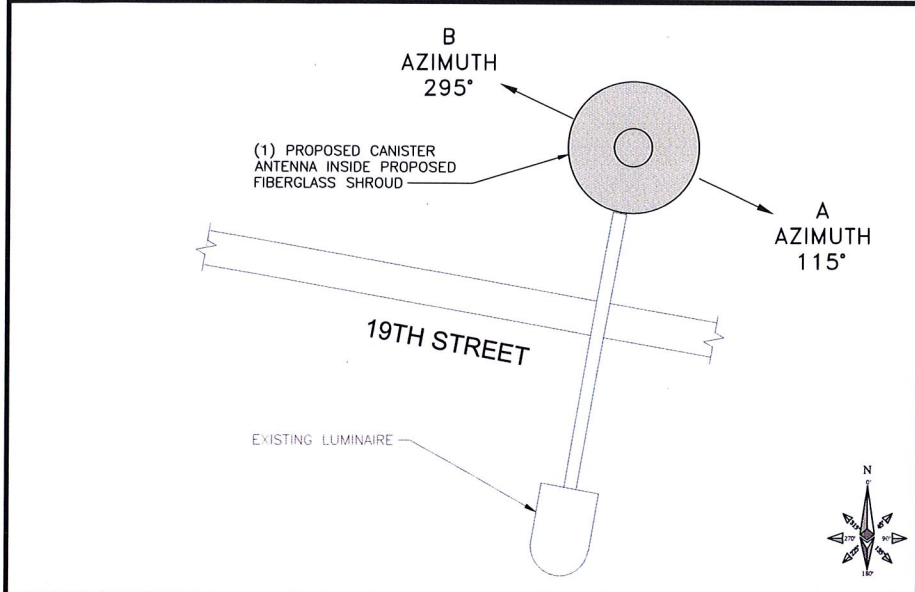

ANTENNA SPACE PLAN VIEW NO SCALE 1

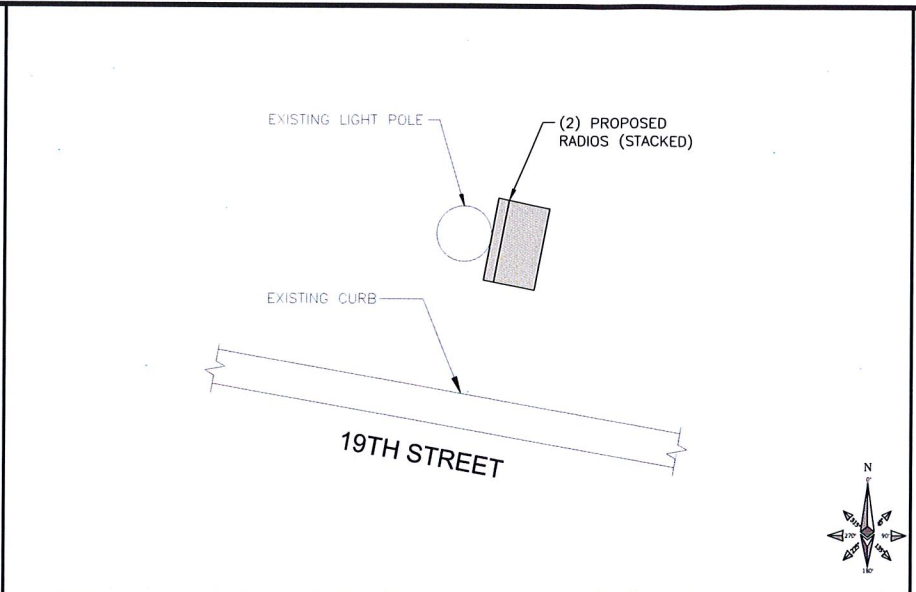

RADIO SPACE PLAN VIEW NO SCALE 2

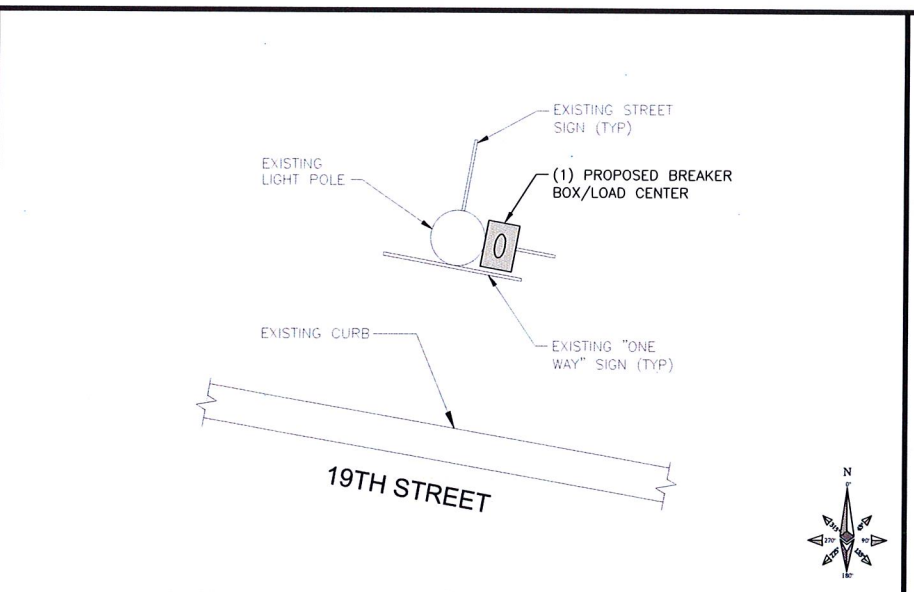

EQUIPMENT PLAN VIEW NO SCALE 3

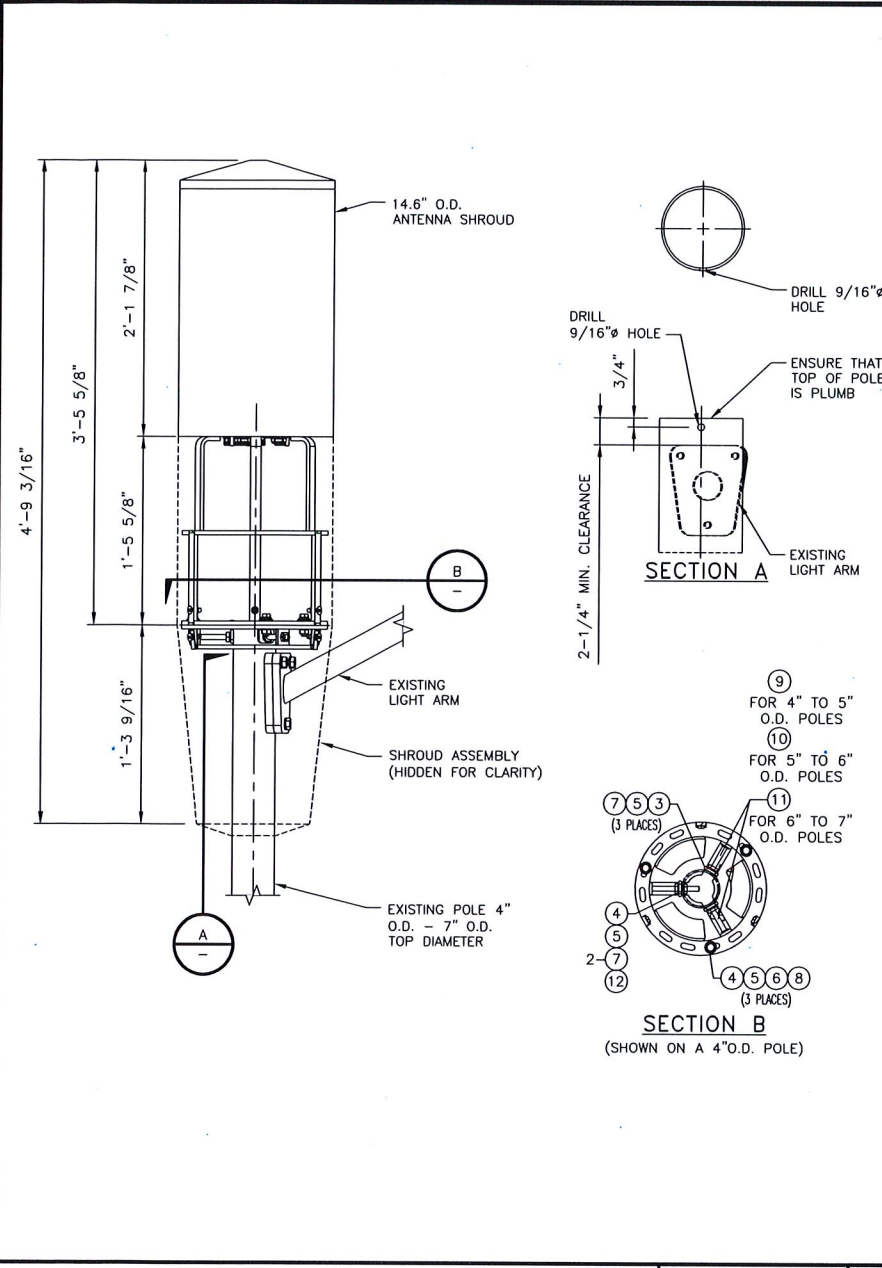

SHROUD/ANTENNA ELEVATION VIEW NO SCALE 1

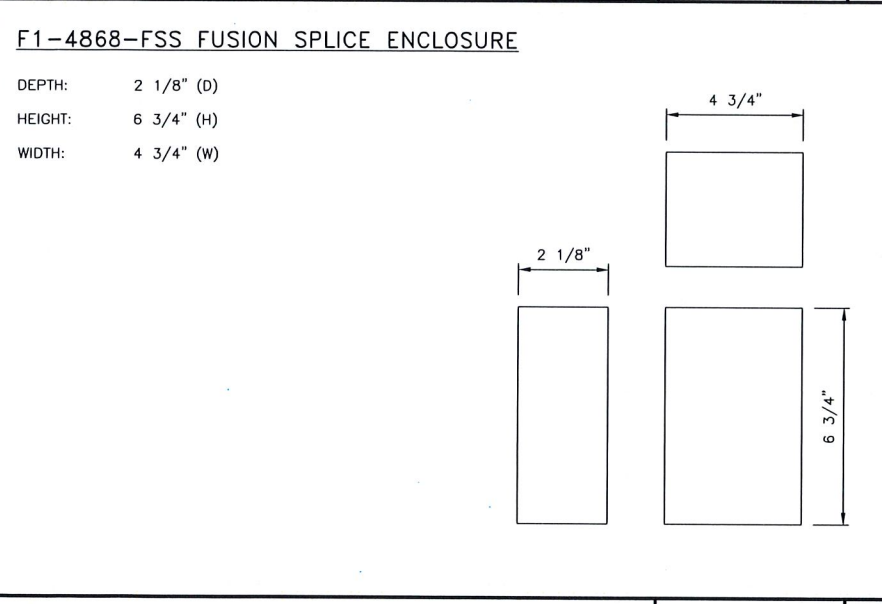

FIBER SPLICE BOX SPECIFICATIONS NO SCALE 6

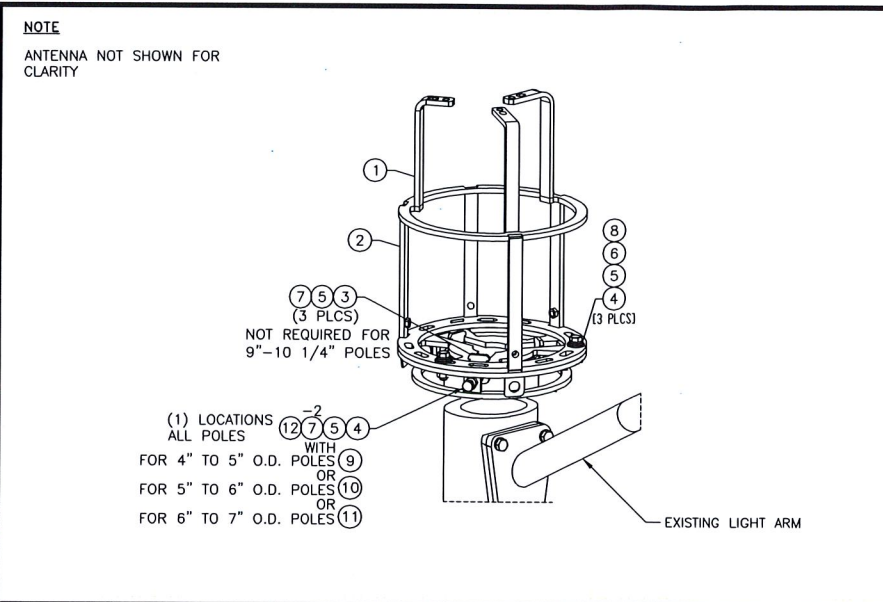

CLAMP-ON BRACKET NO SCALE 2

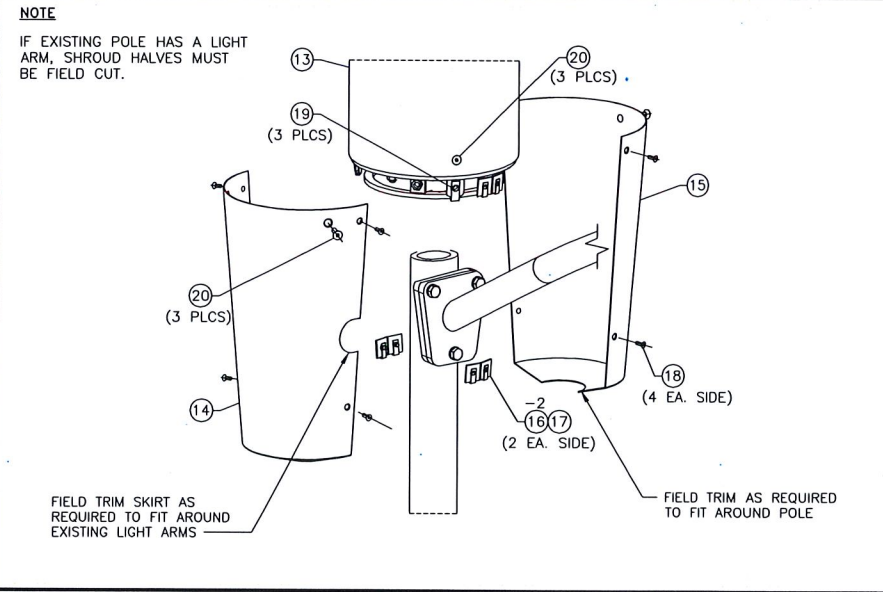

SHROUD ASSEMBLY NO SCALE 4

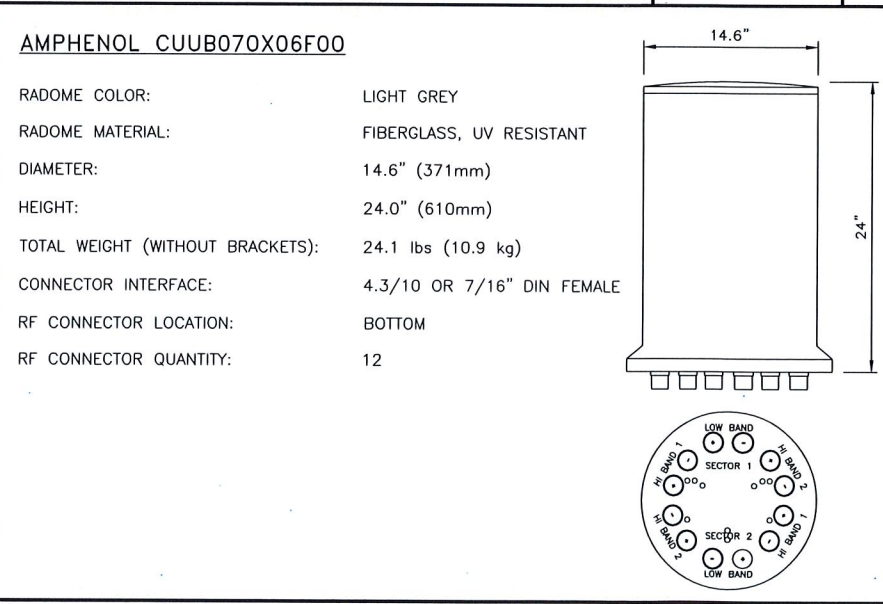

ANTENNA SPECIFICATIONS NO SCALE 7

ITEM #	PART #	DESCRIPTION	QTY.	UNIT WT. (lbs)
CLAMP-ON BRACKET PARTS				
1	WA-1185	3/8" x 1-1/8" O.D. A36, TOP MOUNT WLDMNT	1	18.1
2	WA-1194	3/8" x 13/8" O.D. A36, TOP CAP WLDMNT	1	13.9
3	PL-1655	1/4"x1 5/8"x2 1/8" A36, PLATE	3	0.2
SHROUD PARTS				
4	WA-1193	14GA. x 14 1/4" TD x 4 1/4" BD x 15 9/16" A569, SKIRT	2	7.6
5	14.25R17.625	14 1/4" O.D. x 17 5/8" FIBERGLASS SHROUD HALF	2	2
6	14209-4	11GA. x 1 1/2" x 2 15/16" A36, FORMED PLATE	4	0.1
HARDWARE				
7	70399	1/4" x 3/4" SS, CNTR SUNK SCKET HD SCREW	8	0.01
8	55500	1/4-20 U-STYLE SPEED NUT	8	0.02
9	91137	3/8" x 1" ROUND HEAD SLOTTED NYLON SCREW	4	0.01
10	70428	3/8" x 1 1/4" S.S. COUNTERSUNK SCKET HD SCREW	12	0.01
11	55510	3/8-16 SPEED NUT	4	0.04
12	71011	1/2" x 1 1/2" S.S. BOLT	2	0.1
13	71012F	1/2" x 1 3/4" S.S. FULLY TH'D BOLT	3	0.1
14	71013F	1/2" x 2" S.S. FULLY TH'D BOLT	2	0.2
15	71015F	1/2" x 2 1/2" S.S. FULLY TH'D BOLT	2	0.2
16	71052F	1/2" x 3" S.S. FULLY TH'D BOLT	2	0.2
17	71051F	1/2" x 3 1/2" S.S. FULLY TH'D BOLT	2	0.2
18	71053F	1/2" x 4" S.S. FULLY TH'D BOLT	2	0.3
19	80333	1/2" x 6" S.S. THREADED ROD	1	0.3
20	44005	1/2" NYLON FLAT WASHER	3	0.01
21	40027	1/2" x 1.032" O.D. x .121" S.S. FLAT WASHER	4	0.02
22	43020	1/2" S.S. LOCK WASHER	7	0.01
23	52005	1/2" S.S. JAM NUT	5	0.04
TOTAL GALV. WT.			128	

EQUIPMENT TABLE NO SCALE 3

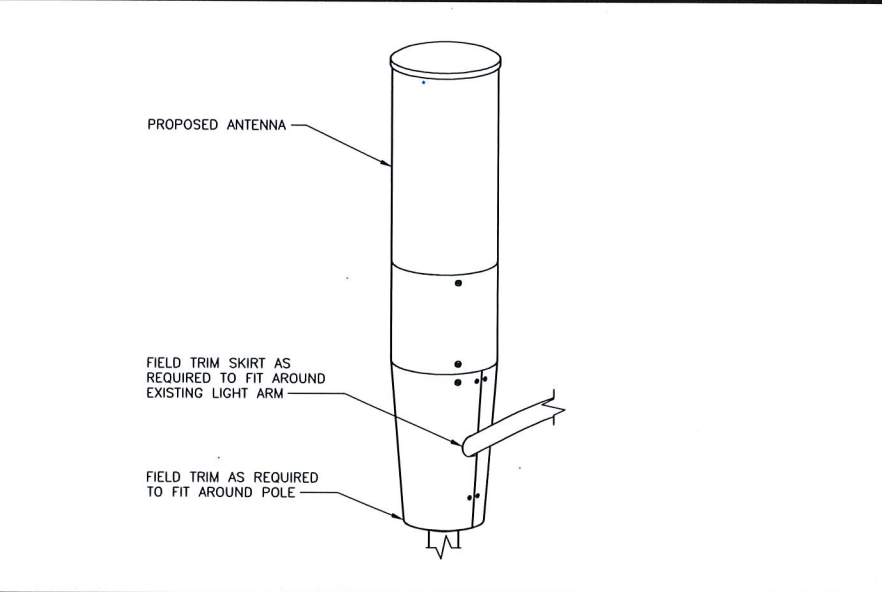

SHROUD ASSEMBLY (AS ASSEMBLED) NO SCALE 5

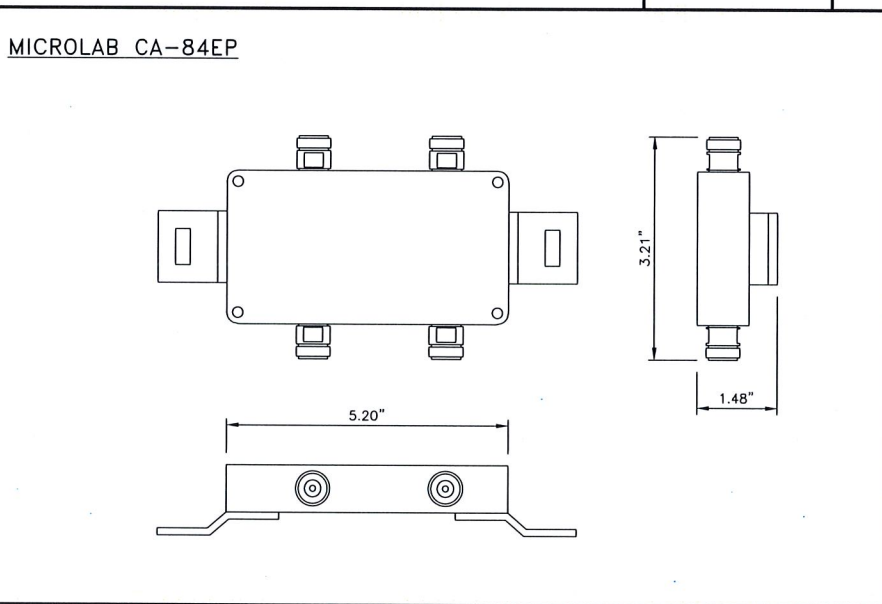

DIPLEXER SPECIFICATIONS NO SCALE 8



INTERNAL REVIEW

CONSTRUCTION SIGNATURE _____ DATE _____

RF SIGNATURE _____ DATE _____

REAL ESTATE SIGNATURE _____ DATE _____



THESE DRAWINGS ARE COPYRIGHTED AND ARE THE PROPERTY OF BLACK & VEATCH; PRODUCED SOLELY FOR THE USE OF OUR CLIENT. ANY REPRODUCTION OR USE OF THE INFORMATION CONTAINED WITHIN SAID DRAWINGS IS PROHIBITED WITHOUT WRITTEN CONSENT BY BLACK & VEATCH.

PROJECT NO.	DRAWN BY	CHECKED BY
192417.5561	LEW	LW

REV	DATE	DESCRIPTION
B	03/14/17	ISSUED FOR REVIEW
A	03/06/17	ISSUED FOR REVIEW

PRELIMINARY

IT IS A VIOLATION OF LAW FOR ANY PERSON, UNLESS THEY ARE ACTING UNDER THE DIRECTION OF A LICENSED PROFESSIONAL ENGINEER, TO ALTER THIS DOCUMENT.

EXTENET SYSTEMS (CA) LLC
2000 CROW CANYON PLACE
SUITE 210
SAN RAMON, CA 94583

SITE ADDRESS
ADJACENT TO (IN PROW)
222 19TH ST
OAKLAND, CA 94612

SHEET TITLE
EQUIPMENT DETAILS

SHEET NUMBER
C-3

ERICSSON RRUS-32

LENGTH: 27.17" (690MM)
 WIDTH: 12.05" (306MM)
 DEPTH: 7.01" (178MM)
 TOTAL WEIGHT (WITHOUT BRACKETS): <23 Kg

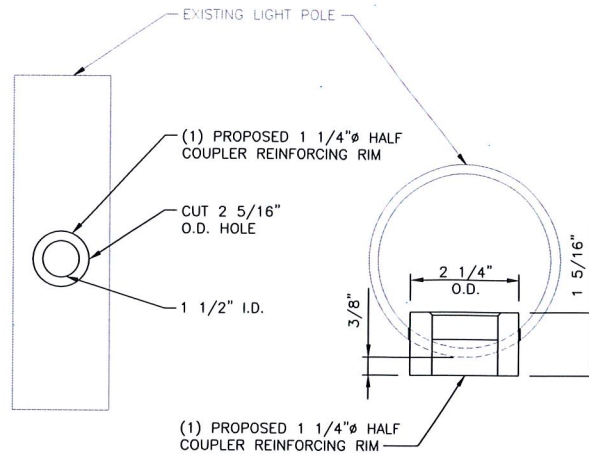
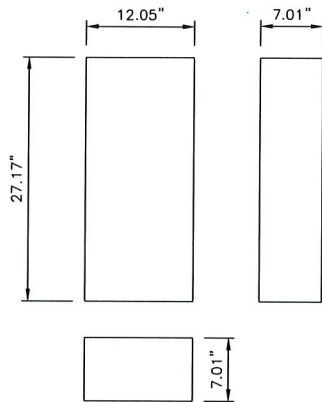

NOTICE

Beyond This Point you are entering a controlled area where RF emissions *may exceed* the FCC General Population Exposure Limits.

Follow all posted signs and site guidelines for working in a RF environment.

Ref: 47CFR 1.1307(b)

CAUTION

Beyond This Point you are entering a controlled area where RF emissions *may exceed* the FCC Occupational Exposure Limits.

Obey all posted signs and site guidelines for working in a RF environment.

Ref: 47CFR 1.1307(b)

NOTE: SPECIFIC EME PLACARD WILL BE PLACED AFTER EME REPORT



INTERNAL REVIEW	
CONSTRUCTION SIGNATURE	DATE
RF SIGNATURE	DATE
REAL ESTATE SIGNATURE	DATE

BLACK & VEATCH

BLACK & VEATCH CORPORATION
 2999 OAK ROAD
 SUITE 490
 WALNUT CREEK, CA 94597

THESE DRAWINGS ARE COPYRIGHTED AND ARE THE PROPERTY OF BLACK & VEATCH; PRODUCED SOLELY FOR THE USE OF OUR CLIENT. ANY REPRODUCTION OR USE OF THE INFORMATION CONTAINED WITHIN SAID DRAWINGS IS PROHIBITED WITHOUT WRITTEN CONSENT BY BLACK & VEATCH.

PROJECT NO.	DRAWN BY	CHECKED BY
192417.5561	LEW	LW

REV	DATE	DESCRIPTION
B	03/14/17	ISSUED FOR REVIEW
A	03/06/17	ISSUED FOR REVIEW

PRELIMINARY

IT IS A VIOLATION OF LAW FOR ANY PERSON, UNLESS THEY ARE ACTING UNDER THE DIRECTION OF A LICENSED PROFESSIONAL ENGINEER, TO ALTER THIS DOCUMENT.

EXTENET SYSTEMS (CA) LLC
 2000 CROW CANYON PLACE
 SUITE 210
 SAN RAMON, CA 94583

SITE ADDRESS
 ADJACENT TO (IN PROW)
 222 19TH ST
 OAKLAND, CA 94612

SHEET TITLE
 EQUIPMENT DETAILS

SHEET NUMBER
C-4

RADIO SPECIFICATIONS

NO SCALE 1

VERTICAL ACCESS PORT DETAIL

NO SCALE 2

RF SIGNAGE DETAILS

NO SCALE 3

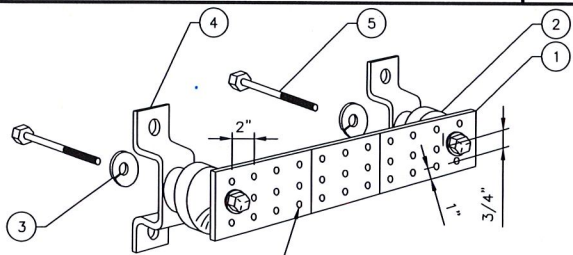

- LEGEND**
1. COPPER TINNED GROUND BAR HOLE CENTERS TO MATCH NEMA DOUBLE LUG CONFIGURATION
 2. INSULATORS
 3. 5/8" LOCKWASHERS
 4. WALL MOUNTING BRACKETS
 5. 5/8"-11 X 1" H.H.C.S. BOLTS

GROUND BAR

NO SCALE 4

NOT USED

NO SCALE 5

MURRAY LW002GRU SPECIFICATIONS

LOAD CENTER DEPTH: 3.625"
 LOAD CENTER WIDTH: 5.2"
 LOAD CENTER HEIGHT: 8.125"
 WEIGHT: 4.55 LB
 LOAD CENTER TYPE: MAIN LUG
 MAX AMPERAGE: 60
 MOUNTING TYPE: PLUG IN
 NUMBER OF PHASES: 1
 NUMBER OF SPACES: 2
 VOLTAGE (VOLTS): 120/240
 INDOOR/OUTDOOR: OUTDOOR
 ELECTRICAL PRODUCT TYPE: LOAD CENTER

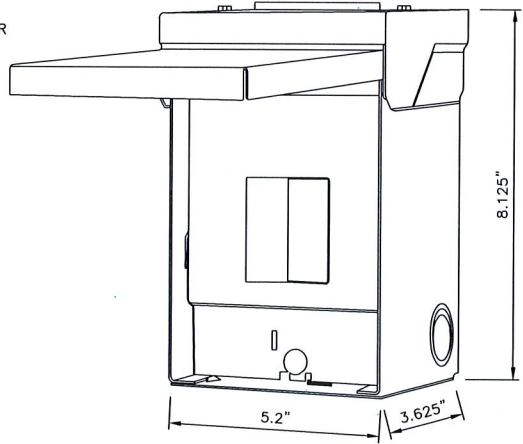

PROPOSED MOUNTING BRACKET (TYP)

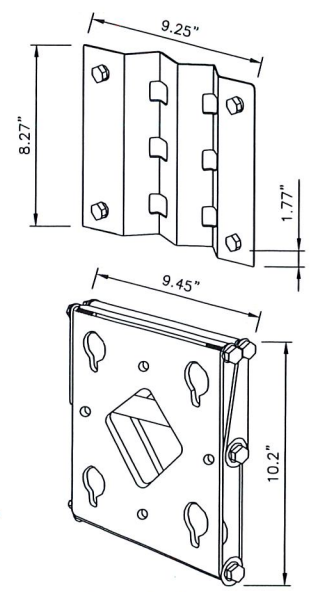
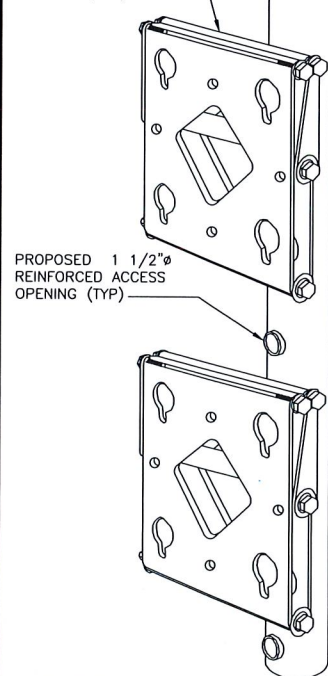

RADIO POLE MOUNTING DETAILS

NO SCALE 7

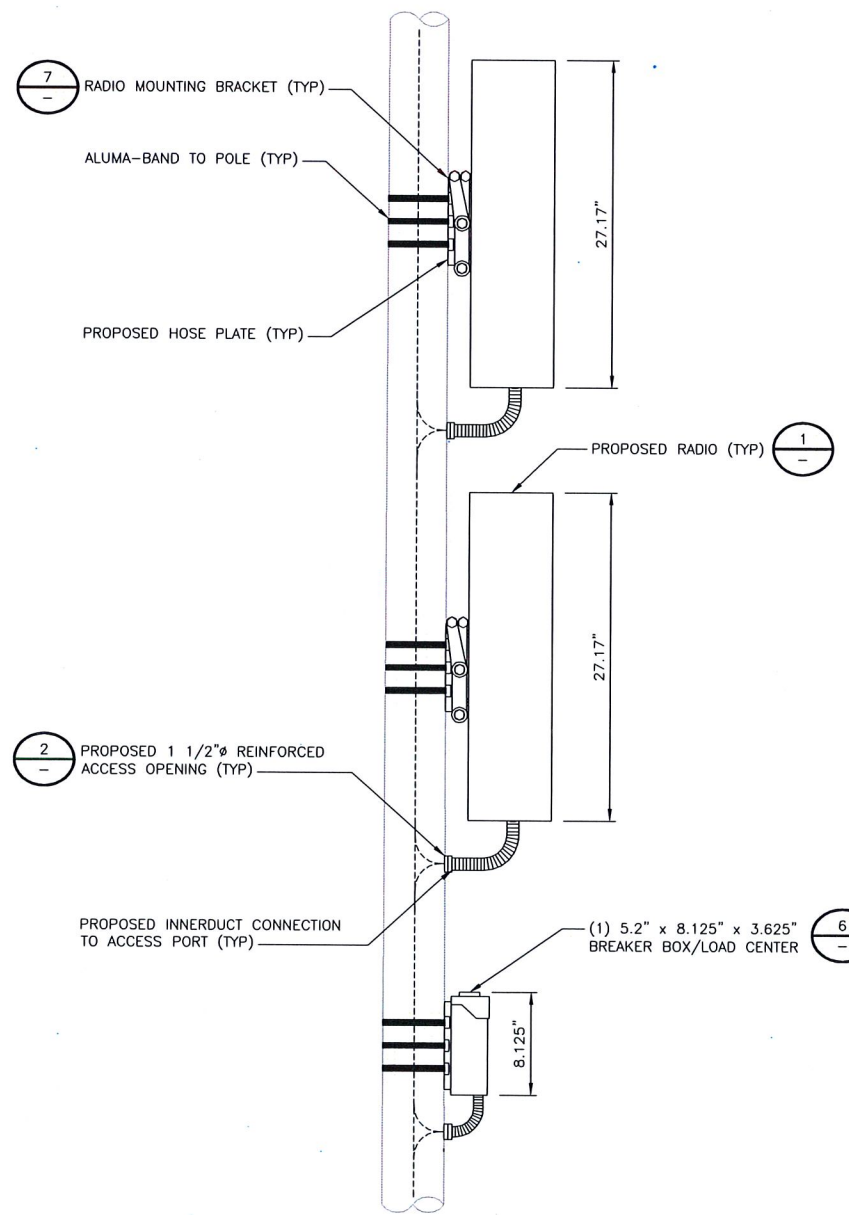

EQUIPMENT PLACEMENT DETAIL

NO SCALE 8

BREAKER BOX SPECIFICATIONS

NO SCALE 6

NW-CA-DTOAKLAN-VZW
(Option 2)

Amphenol CUUB070X06FxyS

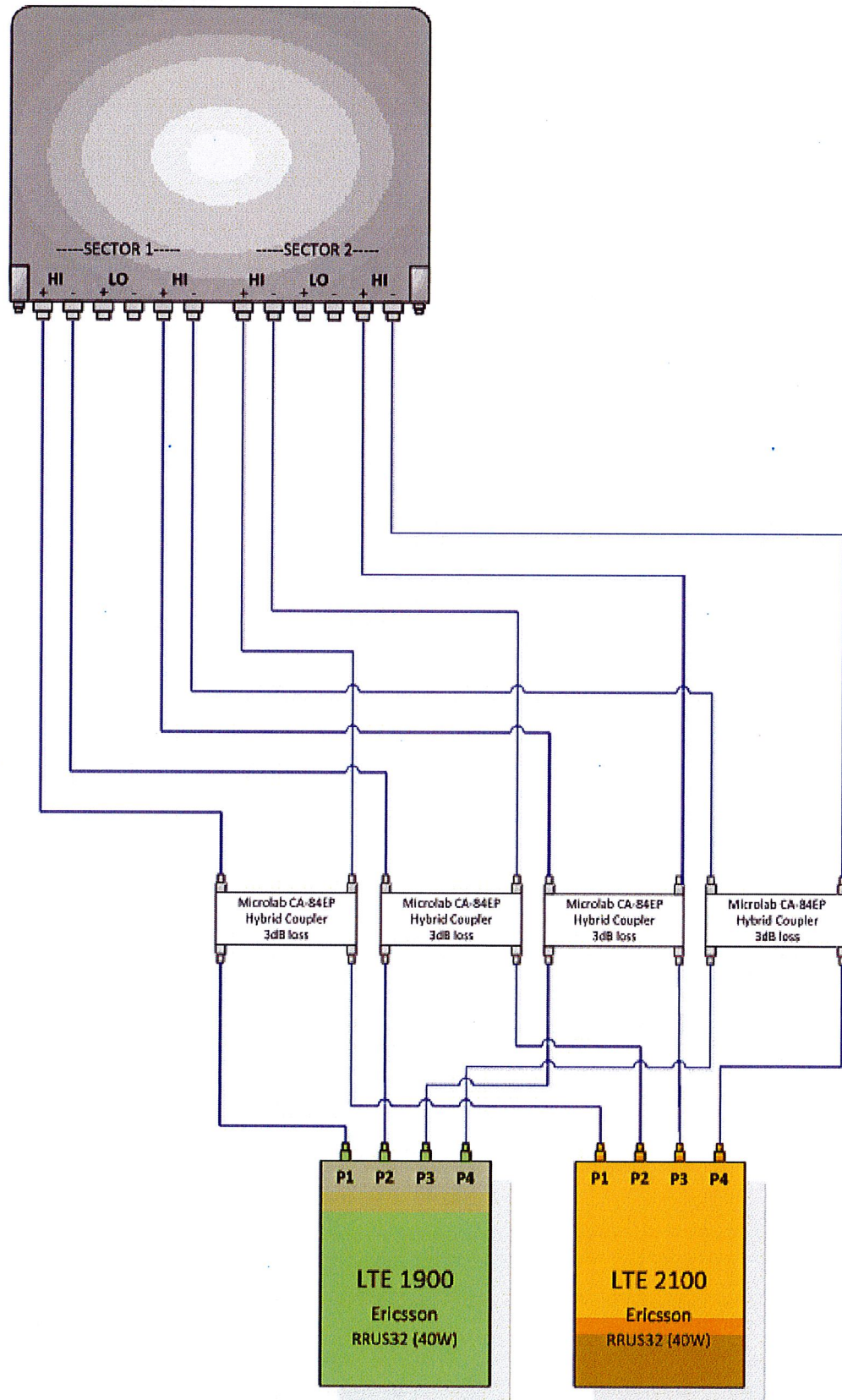

ANTENNA CONFIGURATION

NO SCALE

3

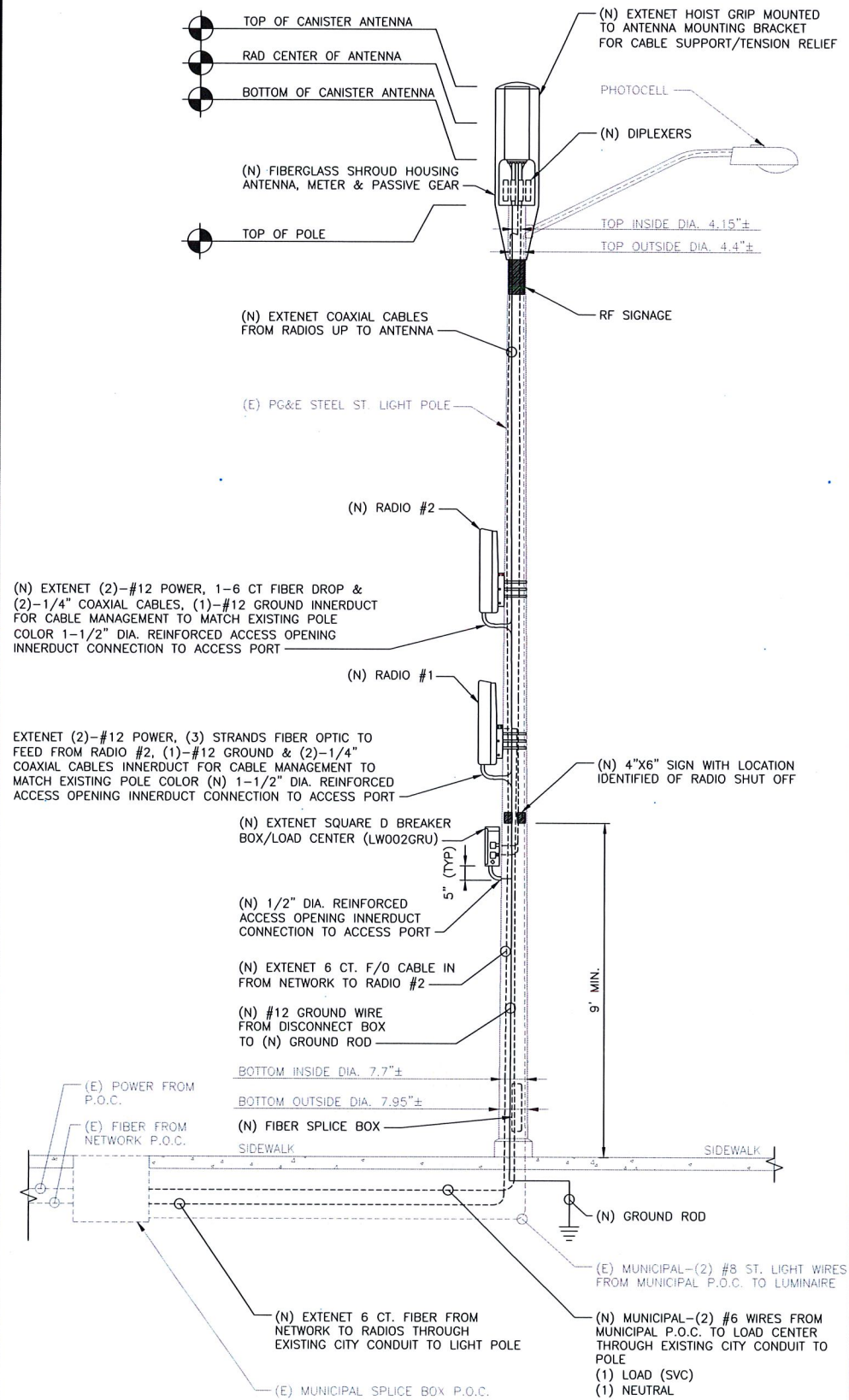

TYPICAL STEEL STREETLIGHT SITE TEMPLATE

NO SCALE

2



INTERNAL REVIEW	
CONSTRUCTION SIGNATURE	DATE
RF SIGNATURE	DATE
REAL ESTATE SIGNATURE	DATE

BLACK & VEATCH
BLACK & VEATCH CORPORATION
2999 OAK ROAD
SUITE 490
WALNUT CREEK, CA 94597

THESE DRAWINGS ARE COPYRIGHTED AND ARE THE PROPERTY OF BLACK & VEATCH; PRODUCED SOLELY FOR THE USE OF OUR CLIENT. ANY REPRODUCTION OR USE OF THE INFORMATION CONTAINED WITHIN SAID DRAWINGS IS PROHIBITED WITHOUT WRITTEN CONSENT BY BLACK & VEATCH.

PROJECT NO.	DRAWN BY	CHECKED BY
192417.5561	LEW	LW

REV	DATE	DESCRIPTION
B	03/14/17	ISSUED FOR REVIEW
A	03/06/17	ISSUED FOR REVIEW

PRELIMINARY

IT IS A VIOLATION OF LAW FOR ANY PERSON, UNLESS THEY ARE ACTING UNDER THE DIRECTION OF A LICENSED PROFESSIONAL ENGINEER, TO ALTER THIS DOCUMENT.

EXTENET SYSTEMS (CA) LLC
2000 CROW CANYON PLACE
SUITE 210
SAN RAMON, CA 94583

SITE ADDRESS
ADJACENT TO (IN PROW)
222 19TH ST
OAKLAND, CA 94612

SHEET TITLE
CONCEPTUAL
WIRING DIAGRAMS

SHEET NUMBER
C-5

Attachment A

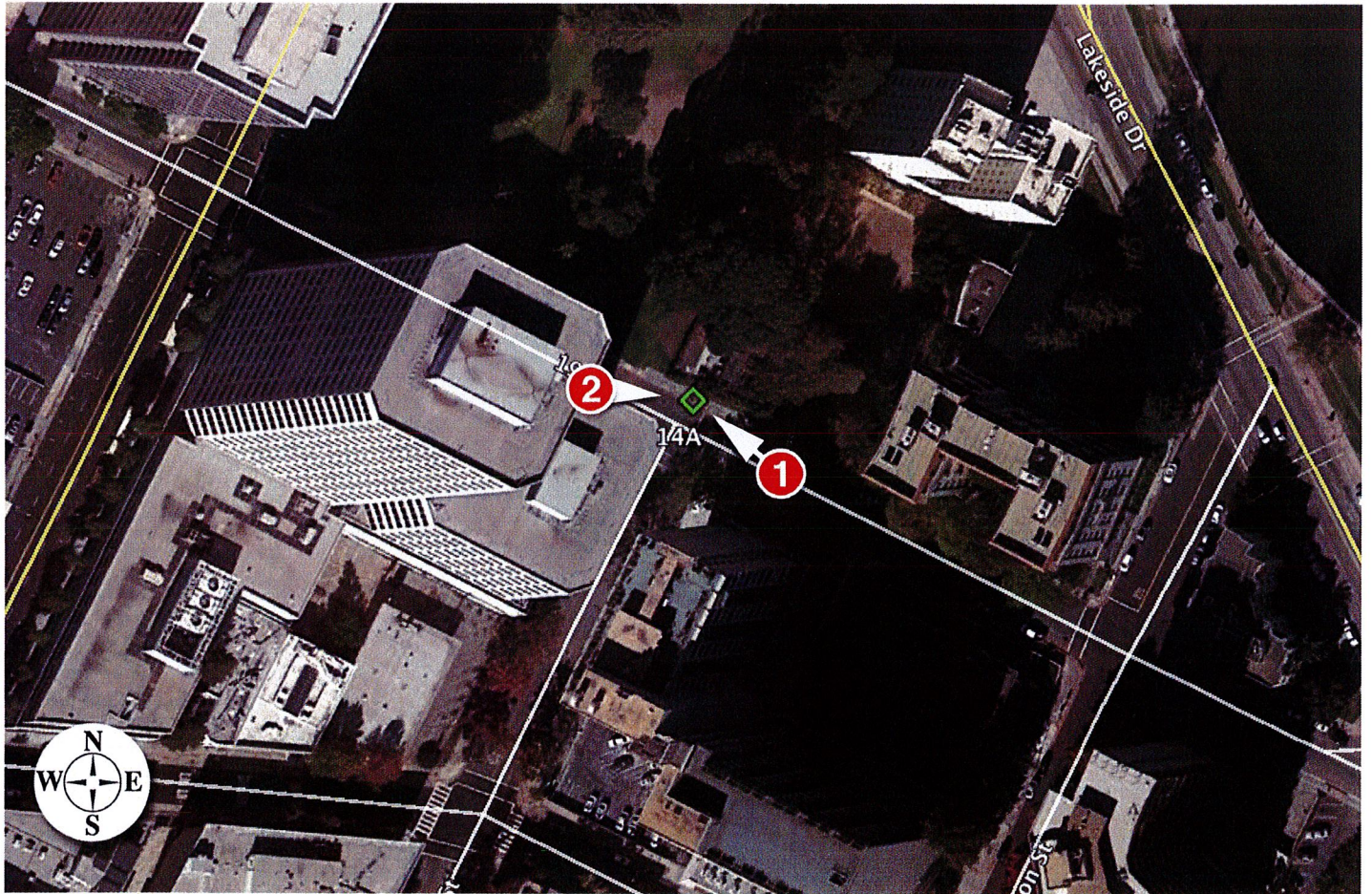



Existing



proposed antenna

Proposed



**ExteNet Systems CA, LLC • Proposed Small Cell (Node No. 00014A)
222 19th Street • Oakland, California**

Statement of Hammett & Edison, Inc., Consulting Engineers

The firm of Hammett & Edison, Inc., Consulting Engineers, has been retained on behalf of ExteNet Systems CA, LLC, a wireless telecommunications facilities provider, to evaluate the addition of Node No. 00014A to be added to the ExteNet small cell network in Oakland, California, for compliance with appropriate guidelines limiting human exposure to radio frequency ("RF") electromagnetic fields.

Executive Summary

ExteNet proposes to install a cylindrical antenna on a light pole sited in the public right-of-way at 222 19th Street in Oakland. The proposed operation will comply with the FCC guidelines limiting public exposure to RF energy.

Prevailing Exposure Standards

The U.S. Congress requires that the Federal Communications Commission ("FCC") evaluate its actions for possible significant impact on the environment. A summary of the FCC's exposure limits is shown in Figure 1. These limits apply for continuous exposures and are intended to provide a prudent margin of safety for all persons, regardless of age, gender, size, or health. The most restrictive FCC limit for exposures of unlimited duration to radio frequency energy for several personal wireless services are as follows:

Wireless Service	Frequency Band	Occupational Limit	Public Limit
Microwave (Point-to-Point)	5,000–80,000 MHz	5.00 mW/cm ²	1.00 mW/cm ²
BRS (Broadband Radio)	2,600	5.00	1.00
AWS (Advanced Wireless)	2,100	5.00	1.00
PCS (Personal Communication)	1,950	5.00	1.00
Cellular	870	2.90	0.58
SMR (Specialized Mobile Radio)	855	2.85	0.57
700 MHz	700	2.35	0.47
[most restrictive frequency range]	30–300	1.00	0.20

General Facility Requirements

Wireless nodes typically consist of two distinct parts: the electronic transceivers (also called "radios" or "channels") that are connected to a central "hub" (which in turn are connected to the traditional wired telephone lines), and the passive antenna(s) that send the wireless signals created by the radios out to be received by individual subscriber units. The radios are often located on the same pole as the antennas and are connected to the antennas by coaxial cables. Because of the short wavelength of the frequencies assigned by the FCC for wireless services, the antennas require line-of-sight paths for their signals to propagate well and so are installed at some height above ground. The antennas are designed



**ExteNet Systems CA, LLC • Proposed Small Cell (Node No. 00014A)
222 19th Street • Oakland, California**

to concentrate their energy toward the horizon, with very little energy wasted toward the sky or the ground. This means that it is generally not possible for exposure conditions to approach the maximum permissible exposure limits without being physically very near the antennas.

Computer Modeling Method

The FCC provides direction for determining compliance in its Office of Engineering and Technology Bulletin No. 65, "Evaluating Compliance with FCC-Specified Guidelines for Human Exposure to Radio Frequency Radiation," dated August 1997. Figure 2 attached describes the calculation methodologies, reflecting the facts that a directional antenna's radiation pattern is not fully formed at locations very close by (the "near-field" effect) and that at greater distances the power level from an energy source decreases with the square of the distance from it (the "inverse square law"). The conservative nature of this method for evaluating exposure conditions has been verified by numerous field tests.

Site and Facility Description

Based upon information provided by ExteNet, including drawings by Black & Veatch Corporation, dated March 14, 2017, it is proposed to install one Amphenol Model CUUB070X06F00 2-foot tall, bi-directional cylindrical antenna on a light pole sited in the public right-of-way in front of the park located at 222 19th Street in Oakland. The antenna would employ no downtilt, would be mounted at an effective height of about 30 feet above ground, and its principal directions would be oriented toward 115°T and 295°T. Verizon proposes to operate from this facility with a maximum effective radiated power in any direction of 1,800 watts, representing simultaneous operation at 940 watts for AWS and 860 watts for PCS service. There are reported no other wireless telecommunications base stations at this site or nearby.

Study Results

For a person anywhere at ground, the maximum RF exposure level due to the proposed Verizon operation is calculated to be 0.011 mW/cm², which is 1.1% of the applicable public exposure limit. The maximum calculated level at any nearby building is 4.8% of the public exposure limit. It should be noted that these results include several "worst-case" assumptions and therefore are expected to overstate actual power density levels from the proposed operation.

Recommended Mitigation Measures

Due to its mounting location and height, the ExteNet antenna would not be accessible to the general public, and so no mitigation measures are necessary to comply with the FCC public exposure guidelines. To prevent occupational exposures in excess of the FCC guidelines, it is recommended that appropriate RF safety training be provided to all authorized personnel who have access to the



**ExteNet Systems CA, LLC • Proposed Small Cell (Node No. 00014A)
222 19th Street • Oakland, California**

antenna. No access within 12 feet directly in front of the antenna itself, such as might occur during certain activities, should be allowed while the base station is in operation, unless other measures can be demonstrated to ensure that occupational protection requirements are met. Posting explanatory signs* on the pole at or below the antenna, such that the signs would be readily visible from any angle of approach to persons who might need to work within that distance, would be sufficient to meet FCC-adopted guidelines.

Conclusion

Based on the information and analysis above, it is the undersigned's professional opinion that operation of the node proposed by ExteNet Systems CA, LLC, at 222 19th Street in Oakland, California, will comply with the prevailing standards for limiting public exposure to radio frequency energy and, therefore, will not for this reason cause a significant impact on the environment. The highest calculated level in publicly accessible areas is much less than the prevailing standards allow for exposures of unlimited duration. This finding is consistent with measurements of actual exposure conditions taken at other operating base stations. Training personnel and posting signs is recommended to establish compliance with occupational exposure limitations.

Authorship

The undersigned author of this statement is a qualified Professional Engineer, holding California Registration No. E-18063, which expires on June 30, 2017. This work has been carried out under his direction, and all statements are true and correct of his own knowledge except, where noted, when data has been supplied by others, which data he believes to be correct.

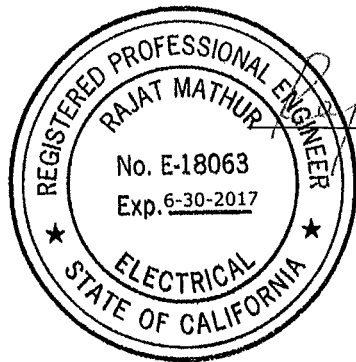

Rajat Mathur
Rajat Mathur, P.E.
707/996-5200

April 25, 2017

* Signs should comply with OET-65 color, symbol, and content recommendations. Contact information should be provided (e.g., a telephone number) to arrange for access to restricted areas. The selection of language(s) is not an engineering matter, and guidance from the landlord, local zoning or health authority, or appropriate professionals may be required.



FCC Radio Frequency Protection Guide

The U.S. Congress required (1996 Telecom Act) the Federal Communications Commission (“FCC”) to adopt a nationwide human exposure standard to ensure that its licensees do not, cumulatively, have a significant impact on the environment. The FCC adopted the limits from Report No. 86, “Biological Effects and Exposure Criteria for Radiofrequency Electromagnetic Fields,” published in 1986 by the Congressionally chartered National Council on Radiation Protection and Measurements (“NCRP”). Separate limits apply for occupational and public exposure conditions, with the latter limits generally five times more restrictive. The more recent standard, developed by the Institute of Electrical and Electronics Engineers and approved as American National Standard ANSI/IEEE C95.1-2006, “Safety Levels with Respect to Human Exposure to Radio Frequency Electromagnetic Fields, 3 kHz to 300 GHz,” includes similar limits. These limits apply for continuous exposures from all sources and are intended to provide a prudent margin of safety for all persons, regardless of age, gender, size, or health.

As shown in the table and chart below, separate limits apply for occupational and public exposure conditions, with the latter limits (in *italics* and/or dashed) up to five times more restrictive:

Frequency Applicable Range (MHz)	Electromagnetic Fields (f is frequency of emission in MHz)					
	Electric Field Strength (V/m)		Magnetic Field Strength (A/m)		Equivalent Far-Field Power Density (mW/cm ²)	
0.3 – 1.34	614	<i>614</i>	1.63	<i>1.63</i>	100	<i>100</i>
1.34 – 3.0	614	<i>823.8/f</i>	1.63	<i>2.19/f</i>	100	<i>180/f²</i>
3.0 – 30	1842/f	<i>823.8/f</i>	4.89/f	<i>2.19/f</i>	900/f ²	<i>180/f²</i>
30 – 300	61.4	<i>27.5</i>	0.163	<i>0.0729</i>	1.0	<i>0.2</i>
300 – 1,500	3.54√f	<i>1.59√f</i>	√f/106	<i>√f/238</i>	f/300	<i>f/1500</i>
1,500 – 100,000	137	<i>61.4</i>	0.364	<i>0.163</i>	5.0	<i>1.0</i>

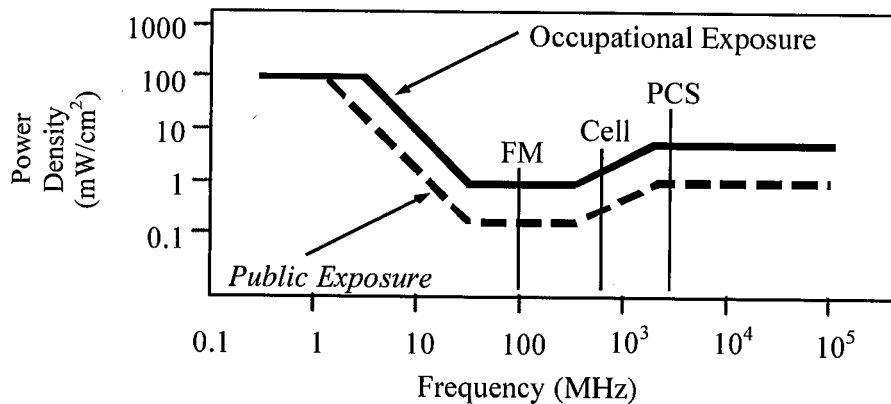

Higher levels are allowed for short periods of time, such that total exposure levels averaged over six or thirty minutes, for occupational or public settings, respectively, do not exceed the limits, and higher levels also are allowed for exposures to small areas, such that the spatially averaged levels do not exceed the limits. However, neither of these allowances is incorporated in the conservative calculation formulas in the FCC Office of Engineering and Technology Bulletin No. 65 (August 1997) for projecting field levels. Hammett & Edison has built those formulas into a proprietary program that calculates, at each location on an arbitrary rectangular grid, the total expected power density from any number of individual radio sources. The program allows for the description of buildings and uneven terrain, if required to obtain more accurate projections.



RFR.CALC™ Calculation Methodology

Assessment by Calculation of Compliance with FCC Exposure Guidelines

The U.S. Congress required (1996 Telecom Act) the Federal Communications Commission ("FCC") to adopt a nationwide human exposure standard to ensure that its licensees do not, cumulatively, have a significant impact on the environment. The maximum permissible exposure limits adopted by the FCC (see Figure 1) apply for continuous exposures from all sources and are intended to provide a prudent margin of safety for all persons, regardless of age, gender, size, or health. Higher levels are allowed for short periods of time, such that total exposure levels averaged over six or thirty minutes, for occupational or public settings, respectively, do not exceed the limits.

Near Field.

Prediction methods have been developed for the near field zone of panel (directional) and whip (omnidirectional) antennas, typical at wireless telecommunications base stations, as well as dish (aperture) antennas, typically used for microwave links. The antenna patterns are not fully formed in the near field at these antennas, and the FCC Office of Engineering and Technology Bulletin No. 65 (August 1997) gives suitable formulas for calculating power density within such zones.

For a panel or whip antenna, power density $S = \frac{180}{\theta_{BW}} \times \frac{0.1 \times P_{net}}{\pi \times D \times h}$, in mW/cm²,

and for an aperture antenna, maximum power density $S_{max} = \frac{0.1 \times 16 \times \eta \times P_{net}}{\pi \times h^2}$, in mW/cm²,

where θ_{BW} = half-power beamwidth of the antenna, in degrees, and

P_{net} = net power input to the antenna, in watts,

D = distance from antenna, in meters,

h = aperture height of the antenna, in meters, and

η = aperture efficiency (unitless, typically 0.5-0.8).

The factor of 0.1 in the numerators converts to the desired units of power density.

Far Field.

OET-65 gives this formula for calculating power density in the far field of an individual RF source:

power density $S = \frac{2.56 \times 1.64 \times 100 \times RFF^2 \times ERP}{4 \times \pi \times D^2}$, in mW/cm²,

where ERP = total ERP (all polarizations), in kilowatts,

RFF = relative field factor at the direction to the actual point of calculation, and

D = distance from the center of radiation to the point of calculation, in meters.

The factor of 2.56 accounts for the increase in power density due to ground reflection, assuming a reflection coefficient of 1.6 ($1.6 \times 1.6 = 2.56$). The factor of 1.64 is the gain of a half-wave dipole relative to an isotropic radiator. The factor of 100 in the numerator converts to the desired units of power density. This formula has been built into a proprietary program that calculates, at each location on an arbitrary rectangular grid, the total expected power density from any number of individual radiation sources. The program also allows for the description of uneven terrain in the vicinity, to obtain more accurate projections.





Attachment C

**EXTENET OAKLAND
NODE 00014A
222 19TH STREET
ALTERNATIVE SITE ANALYSIS**

MAP OF ALTERNATIVE POLES EVALUATED FOR NODE 00014A

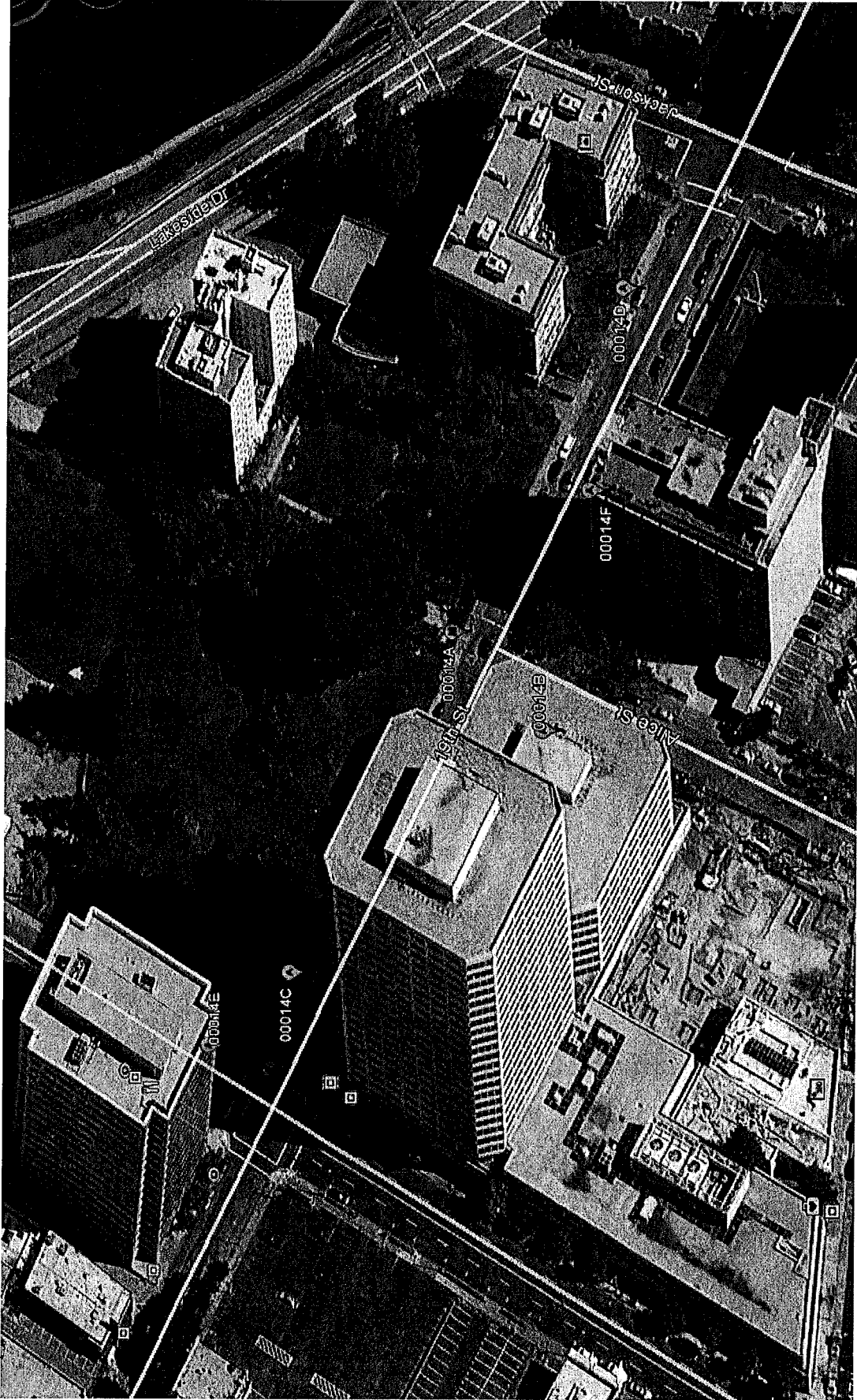

- The above maps depict ExteNet's proposed Node 00014A in relation to other poles in the area that were evaluated as possibly being viable alternative candidates.
- The following is an analysis of each of those 5 alternative locations.

PROPAGATION MAP OF NODES 00014A



This propagation map depicts the ExteNet proposed Node 00014A in relation to surrounding proposed ExteNet small cell nodes.

00014A - PROPOSED LOCATION

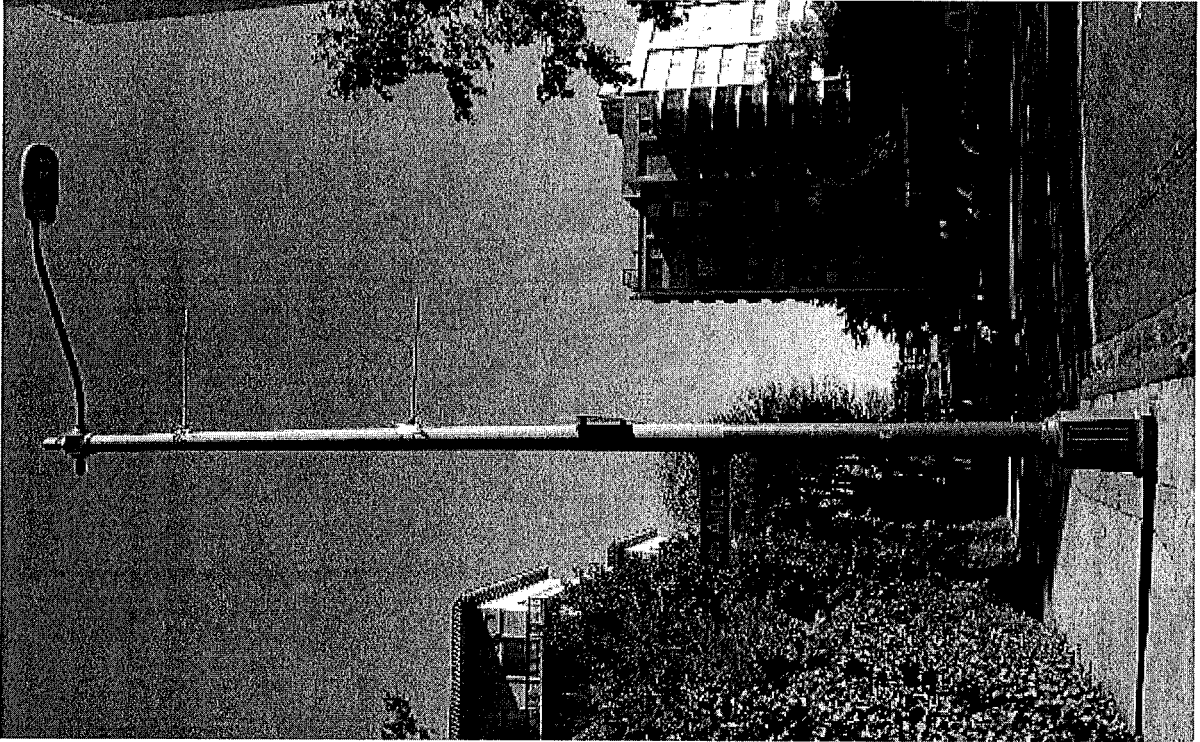

- The location for ExteNet's proposed Node 00014A is a metal light pole located adjacent to 222 19th Street (37.805966, -122.264224).
- ExteNet's objective is to provide Verizon wireless coverage and capacity as well as high speed wireless internet to the Oakland area.
- ExteNet evaluated this site and nearby alternatives to verify that the selected site is the least intrusive means to close Verizon's significant service coverage gap.

ALTERNATIVE NODE 00014B



- Node 00014B is a metal light pole next to 1817 Alice Street (37.805783, -122.264466).
- This pole is not a viable alternative because the signal will be blocked by the building and mature trees on both sides.

ALTERNATIVE NODE 00014C

- Node 00014C is a metal light pole near 274 19th Street (37.806308, -122.265092).
- This pole is not a viable alternative candidate because this pole is located too close to primary Node 00016A .

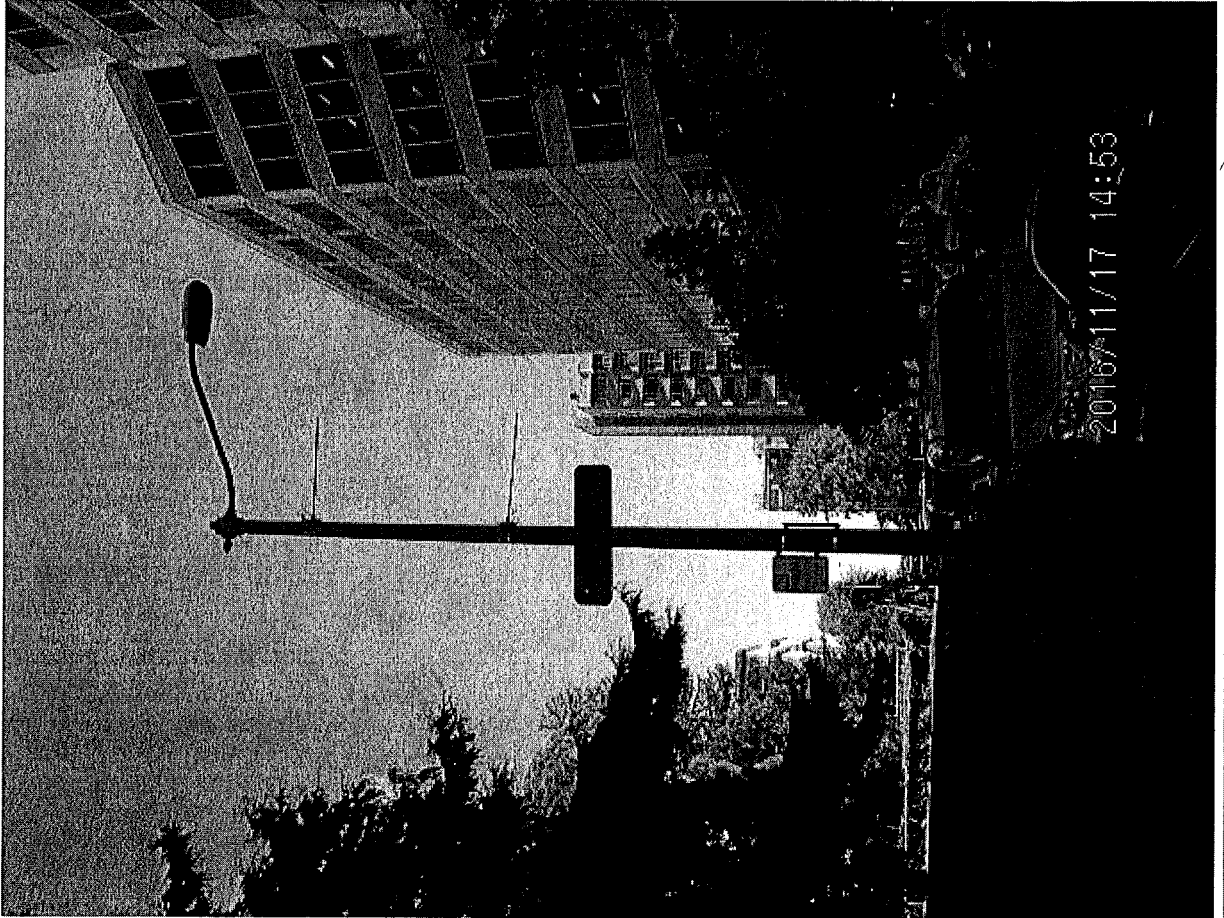

ALTERNATIVE NODE 00014D



2016/11/17 14:57

- Node 00014D is a metal light pole near 201 19th Street (37.805631, -122.263408).
- This pole is not a viable alternative candidate because this pole is located too close to primary Node 00013A .
- This pole is not a viable alternative candidate because this pole is located too close to primary Node 00015A .

ALTERNATIVE NODE 00014E

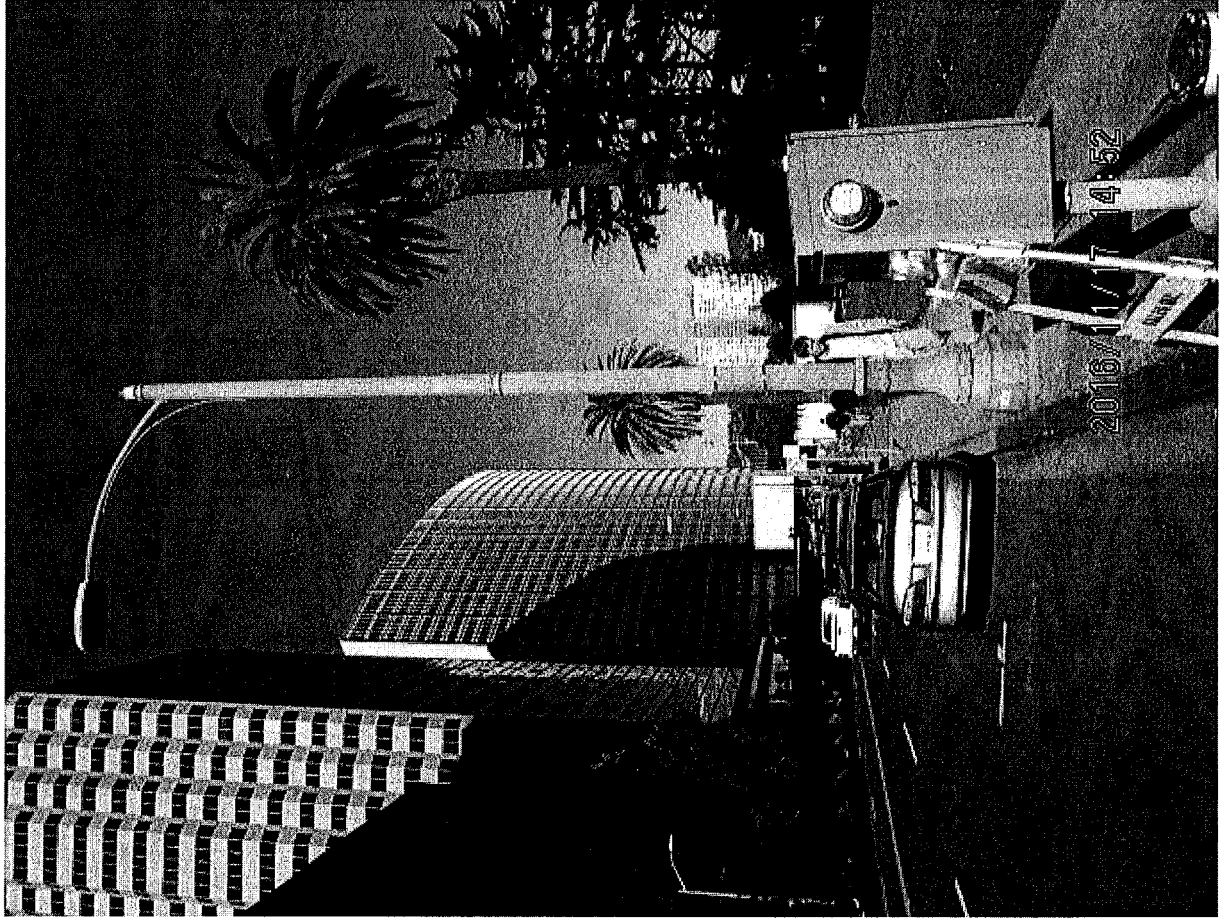

- Node 00014E is a metal light pole near 225 19th Street (37.805694, -122.263887).
- This pole is not a viable alternative because it is a decorative metal light pole.

ALTERNATIVE NODE 00014F

- Node 00014F is a metal light pole near 225 19th Street (37.805694, - 122.263887).
- This pole is not a viable alternative because the signal will be blocked by a tall building.

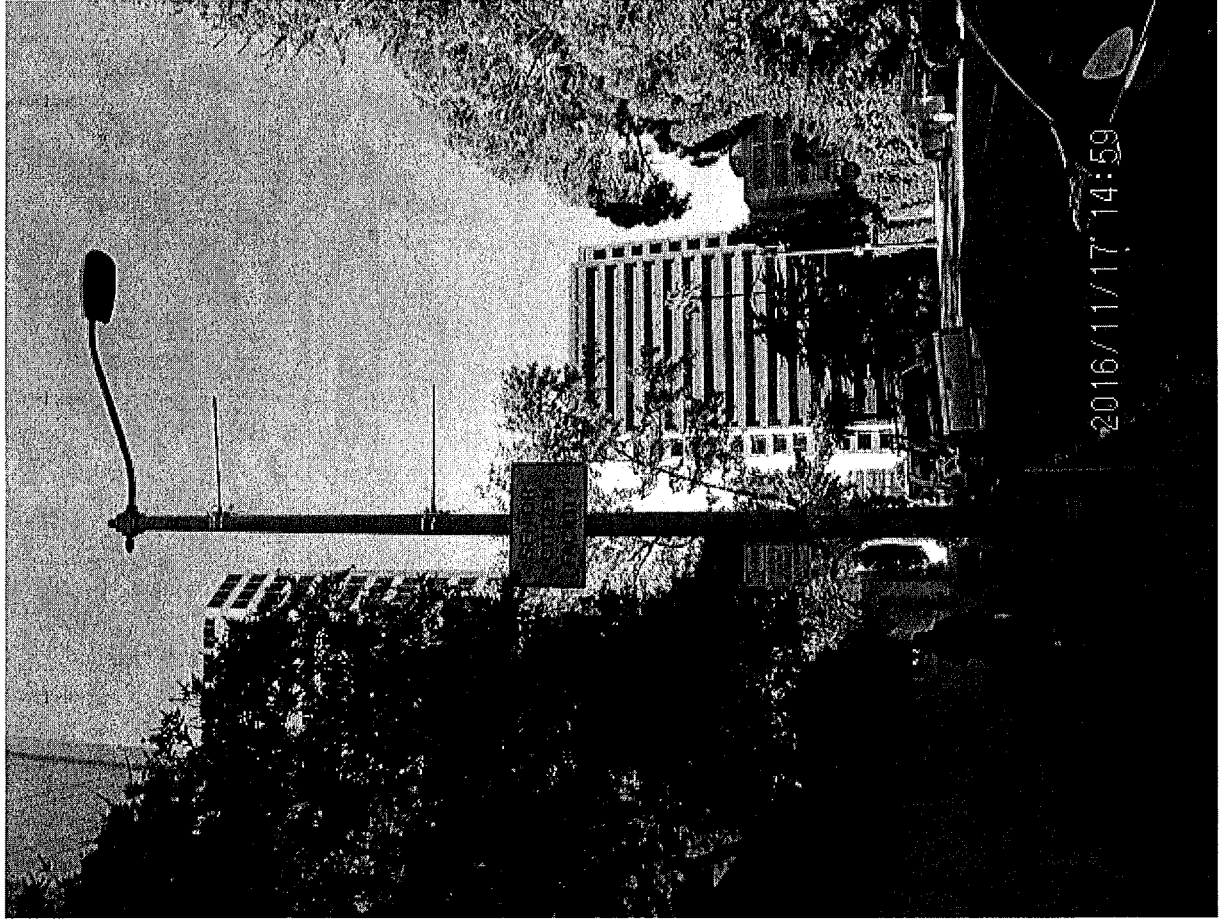

ALTERNATIVE SITE ANALYSIS CONCLUSION

Based on ExteNet's analysis of alternative sites, the currently proposed Node 00014A is the least intrusive location from which to fill the surrounding significant wireless coverage gaps.

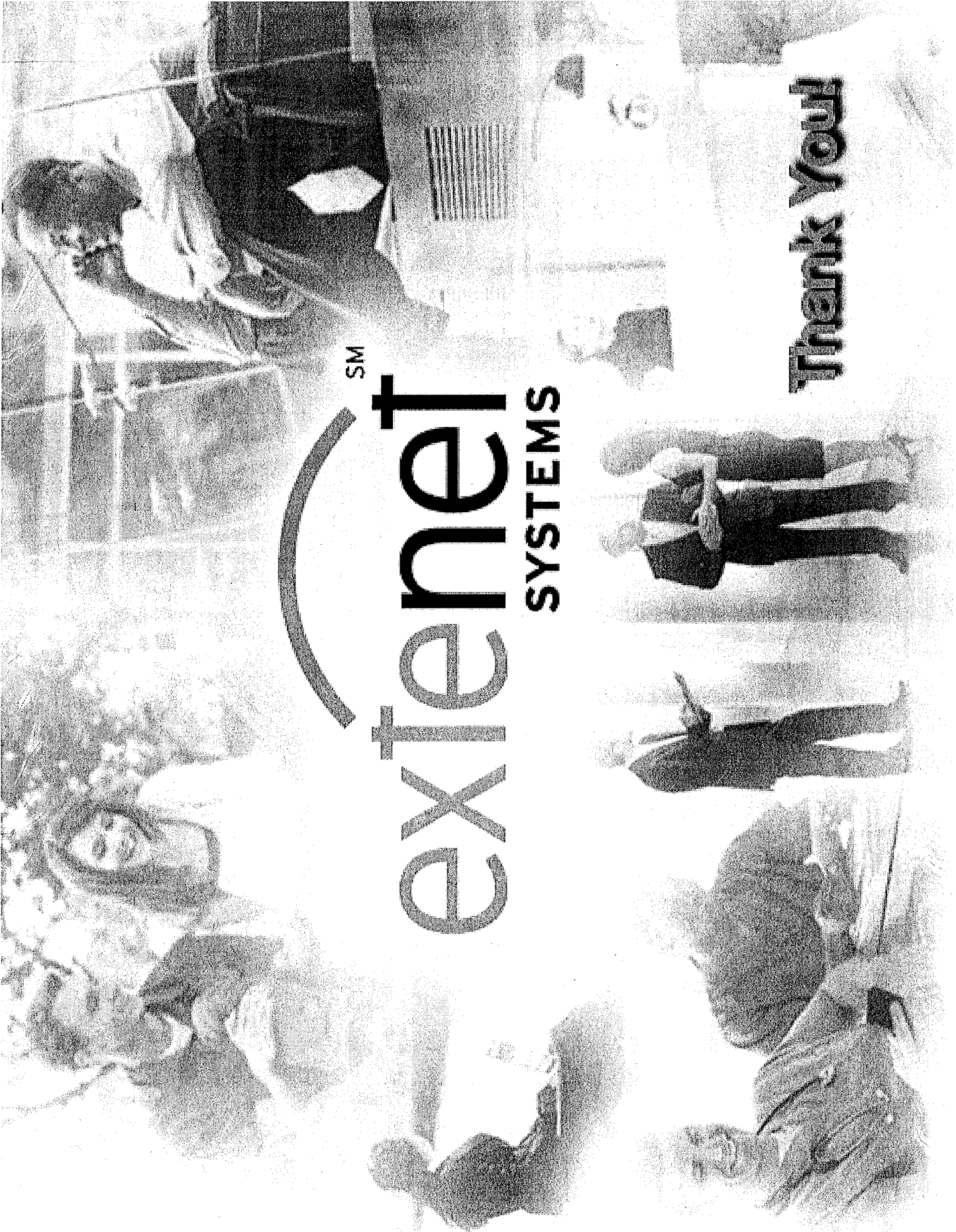

SM
extenet
SYSTEMS

Thank You!

NOTICE OF OAKLAND



CITY OF OAKLAND
BUREAU OF PLANNING
 250 Frank H. Ogawa Plaza, Suite 2114, Oakland, CA 94612
 Phone: 510-238-3911 Fax: 510-238-3912
PLANNING COMMISSION

Location:	The Public Right-of-Way
Assessor's Parcel Number(s):	Adjacent to 008-06342
Proposal:	Installation of a wireless antenna. Existing 27' tall City sign. The project involves installation of a 14.6' in diameter tower with two radio units (12.05' wide and height of 16' and 17'-8" tall, 4 1/2" wide and 2 1/2" tall).
Applicant / Phone Number:	Ana Gomez/Block 88 (913) 458-9148
Owner:	City of Oakland
Case File Number:	PLN17-116
Planning Permits Required:	Major Conditional Use, Monopole Telecommunications located in the public right-of-way.
General Plan:	Central Business District
Zoning:	CBD-R Central Business District
Environmental Determination:	Exempt per Sections 15130 and 15134, additions and alterations to existing structures, new construction or construction projects consistent with the General Plan.
Historic Status:	Non-historic property
City Council District:	3
Date Filed:	April 29, 2017
Action to be Taken:	Decision based on staff recommendation.
Finality of Decision:	Appealable to City Council
For Further Information:	Contact Case Planner, email at inadant@oakland.gov

Your comments and questions, if any, should be directed to the Bureau of Planning, 250 Frank H. Ogawa Plaza, Suite 2114, Oakland, CA 94612. A public hearing will be held on **September 6, 2017** at Oakland City Hall, Council Chambers, 1 Frank H. Ogawa Plaza, Oakland, CA 94612, at 9:00 a.m.

If you challenge the Planning Commission decision on appeal and/or in court, you will be limited to the grounds stated in the notice of appeal and/or in court. If you wish to be notified of the decision, please contact the Bureau of Planning at 510-238-3911.

Please note that the description of the application found above is preliminary in nature and that the final decision is reached by the Planning Commission on these cases, they are not final. An appeal must be filed with the City of Oakland or where the decision is not supported by substantial evidence and must include arguments and evidence previously entered into the record prior to or at the public hearing mentioned above.

POSTING DATE: August 1, 2017
 IT IS UNLAWFUL TO ALTER OR REMOVE THIS NOTICE

PLANNING COMMISSION (510) 238-3911