

<b>Location:</b>	Wooden Utility pole in public right-of-way (sidewalk) adjacent to: 2701 Logan Street
<b>Assessor's Parcel Numbers:</b>	Adjacent to: 026-0763-001-00
<b>Proposal:</b>	To install a new "small cell site" telecommunications facility in order to enhance existing services by attaching two panel antennas on a 38'-3" wooden utility pole located in the public right-of-way. The antennas would be up to 21'-3" in height and equipment mounted at a height of 6'-7" and 14'-4" above ground level.
<b>Applicant / Phone Number:</b>	Ana Gomez/Black & Veatch & Extenet (for: T-Mobile) (913) 458-9148
<b>Owner:</b>	Extenet, et al.
<b>Case File Number:</b>	PLN17307
<b>Planning Permits Required:</b>	Regular Design Review with additional findings for Macro Telecommunications Facility
<b>General Plan:</b>	Mixed Housing Type Residential
<b>Zoning:</b>	RM-3 Mixed Housing Type Residential – 3 Zone
<b>Environmental Determination:</b>	Exempt, Section 15301 of the State CEQA Guidelines: Existing Facilities; Exempt, Section 15302: Replacement or Reconstruction; Exempt, Section 15303: New Construction of Small Structures; Section 15183: Projects Consistent with a Community Plan, General Plan or Zoning
<b>Historic Status:</b>	Non-historic
<b>City Council District:</b>	5
<b>Date Filed:</b>	August 16, 2017
<b>Action to be Taken:</b>	Decision based on staff report
<b>Finality of Decision:</b>	Appealable to City Council within 10 days
<b>For Further Information:</b>	Contact case planner <b>Marilu Garcia</b> at (510) 238-5217 or <a href="mailto:mgarcia2@oaklandnet.com">mgarcia2@oaklandnet.com</a>

**SUMMARY**

The applicant requests Planning Commission approval of a Regular Design Review findings to establish a Macro Telecommunications Facility ("small cell site"). The purpose is to enhance existing wireless services. The project involves attaching an antenna and equipment to an existing utility pole located within the sidewalk in the public right-of-way in a residential neighborhood.

Staff recommends approval, subject to conditions, as described in this report.

**BACKGROUND**

For several years in the City of Oakland, telecommunications carriers have proposed facility installation within the public right-of-way, instead of private property. These facilities typically consist of antennas and associated equipment attached to utility poles or street light poles. Poles are often replaced with replicas for technical purposes. The main purpose is to enhance existing service, given increasing technological demands for bandwidth, through new technology and locational advantages. The City exercises zoning jurisdiction over such projects in response to a 2009 State Supreme Court case decision

# CITY OF OAKLAND PLANNING COMMISSION

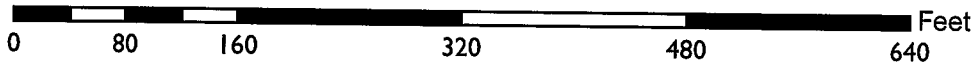

Case File: PLN17307  
Applicant: Ana Gomez/Black & Veatch & Extenet (for: T-Mobile)  
Address: Utility pole in sidewalk adjacent to: 2701 Logan Street  
(along 27th Ave)  
Zone: RM-3

(Sprint v. Palos Verdes Estates). Pursuant to the Planning Code, utility or joint pole authority (JPA) sites are classified by staff as "Macro Facilities," and street light pole sites (lamps, not traffic signals) as "Monopole Facilities." For JPA poles, only Design Review approval may be required, as opposed to Design Review and a Conditional Use Permit, for example. For non-JPA pole sites, such as City light poles, projects also require review by the City's Public Works Agency (PWA) and Real Estate Division, and involve other considerations such as impacts to historical poles. The PWA may also review projects involving street lights. In either case, the practice has been to refer all such projects to the Planning Commission for decision when located in or near a residential zone.

Several projects for new DAS (distributed antenna services) facilities have come before the Planning Commission for a decision and have been installed throughout the Oakland Hills. Some applications have been denied due to view obstructions or propinquity to residences. Improved practices for the processing of all types of sites incorporating Planning Commission direction have been developed as a result. Conditions of approval typically attach requirements such as painting and texturing of approved components to more closely match utility poles in appearance. Approvals do not apply to any replacement project should the poles be removed for any reason. As with sites located on private property, the Federal Government precludes cities from denying an application on the basis of emissions concerns if a satisfactory emissions report is submitted. More recent Federal changes have streamlined the process to service existing facilities.

Currently, telecommunications carriers are in the process of attempting to deploy "small cell sites." These projects also involve attachment of antennas and equipment at public right-of-way facilities such as poles or lights for further enhancement of services. However, components are now somewhat smaller in size than in the past. Also, sites tend to be located in flatland neighborhoods and Downtown where view obstructions are less likely to be an issue. Good design and placement is given full consideration nonetheless, especially with the greater presence of historic structures in Downtown. Additionally, given the sheer multitude of applications, and, out of consideration for Federal requirements for permit processing timelines, staff may develop alternatives to traditional staffing and agendizing.

## **TELECOMMUNICATIONS BACKGROUND**

### **Limitations on Local Government Zoning Authority under the Telecommunications Act of 1996**

Section 704 of the Telecommunications Act of 1996 (TCA) provides federal standards for the siting of "Personal Wireless Services Facilities." "Personal Wireless Services" include all commercial mobile services (including personal communications services (PCS), cellular radio mobile services, and paging); unlicensed wireless services; and common carrier wireless exchange access services. Under Section 704, local zoning authority over personal wireless services is preserved such that the FCC is prevented from preempting local land use decisions; however, local government zoning decisions are still restricted by several provisions of federal law. Specifically:

- Under Section 253 of the TCA, no state or local regulation or other legal requirement can prohibit or have the effect of prohibiting the ability of any entity to provide any interstate or intrastate telecommunications service.
- Further, Section 704 of the TCA imposes limitations on what local and state governments can do. Section 704 prohibits any state and local government action which unreasonably discriminates among personal wireless providers. Local governments must ensure that its wireless ordinance does not contain requirements in the form of regulatory terms or fees which may have the "effect" of prohibiting the placement, construction, or modification of personal wireless services.
- Section 704 also preempts any local zoning regulation purporting to regulate the placement, construction and modification of personal wireless service facilities on the basis, either directly or

indirectly, on the environmental effects of radio frequency emissions (RF) of such facilities, which otherwise comply with Federal Communication Commission (FCC) standards in this regard. (See 47 U.S.C. Section 332(c)(7)(B)(iv) (1996)). This means that local authorities may not regulate the siting or construction of personal wireless facilities based on RF standards that are more stringent than those promulgated by the FCC.

- Section 704 mandates that local governments act upon personal wireless service facility siting applications to place, construct, or modify a facility within a reasonable time (See 47 U.S.C.332(c)(7)(B)(ii) and FCC Shot Clock ruling setting forth “reasonable time” standards for applications deemed complete).
- Section 704 also mandates that the FCC provide technical support to local governments in order to encourage them to make property, rights-of-way, and easements under their jurisdiction available for the placement of new spectrum-based telecommunications services. This proceeding is currently at the comment stage.

For more information on the FCC’s jurisdiction in this area, consult the following:

Competition & Infrastructure Policy Division (CIPD) of the Wireless Telecommunications Bureau, main division number: (202) 418-1310.

Main division website:

<https://www.fcc.gov/general/competition-infrastructure-policy-division-wireless-telecommunications-bureau>

Tower siting:

<https://www.fcc.gov/general/tower-and-antenna-siting>

## **SITE DESCRIPTION**

The project site consists of an existing wooden utility pole located in the public right-of-way (sidewalk, towards the curb) that measures approximately 38-feet in height. The pole hosts power lines on horizontal posts towards its top. The pole is located along 27<sup>th</sup> Street close to the intersection at Logan Street adjacent to the residence at 2701 Logan Street. The split-level residence is located approximately 15 feet southeast. Properties in the vicinity consist of detached single and multi-family homes.

## **PROJECT DESCRIPTION**

The proposal is to establish a Macro Telecommunications Facility (“small cell site”). The project involves the following:

- Use existing 38-foot tall utility pole;
- Install two panel antennas within an antenna support measuring 23.65” tall, 6.7” wide and 4.1” in diameter on the side of the pole up to 21’-3” in height;
- Install two radio units measuring 7.8” tall, 7.8” wide and 3.93” in diameter mounted at a height of 10’-11” and 14’-4” above ground;
- Install associated smart meter and shut down box at a height of 6’-7”, and
- Paint the proposed antennas and associated equipment to match the pole and/or other utilities located on the pole.

## **GENERAL PLAN ANALYSIS**

The site is located in a Mixed Housing Type Residential area under the General Plan’s Land Use and Transportation Element (LUTE). The intent of the area is: “to create, maintain, and enhance residential

areas typically located near the City's major arterials and characterized by a mix of single family homes, townhouses, small multi-unit buildings, and neighborhood businesses where appropriate." Given residents' and visitors' increasing reliance upon cellular service for phone and internet, the proposal for a Macro Telecommunications Facility that is not adjacent to a primary living space or historic structure conforms to this intent.

Staff therefore finds the proposal, as conditioned, to conform to the General Plan.

### ZONING ANALYSIS

The site is located within the Mixed Housing Type Residential – 3 Zone (RM-3). The intent of the RM-3 Zone is: "to create, maintain, and enhance residential areas characterized by a mix of single family homes, duplexes, townhouses, small multi-unit buildings at somewhat higher densities than in RM-2, and neighborhood businesses where appropriate." Per OMC section 17.136.040 and 17.128.080, this project requires a Regular Design Review with additional findings.

Staff finds the proposal, as conditioned, to conform to the Planning Code.

### ENVIRONMENTAL DETERMINATION

The California Environmental Quality Act (CEQA) Guidelines categorically exempts specific types of projects from environmental review. Section 15301 exempts projects involving 'Existing Facilities'; Section 15302 exempts projects involving 'Replacement or Reconstruction'; and, Section 15303 exempts projects involving 'Construction of Small Structures.' The proposal fits all of these descriptions. The project is also subject to Section 15183 for 'Projects consistent with a community plan, general plan or zoning.' The project is therefore exempt from further Environmental Review.

### KEY ISSUES AND IMPACTS

The proposal to establish a Macro Telecommunications Facility is subject to the following Planning Code development standards, which are followed by staff's analysis in relation to this application:

#### 17.128.070 Macro Telecommunications Facilities.

##### A. General Development Standards for Macro Telecommunications Facilities.

**1. The Macro Facilities shall be located on existing buildings, poles or other existing support structures, or shall be post mounted.**

The facility involves attachment to an existing utility pole hosting power lines.

**2. The equipment shelter or cabinet must be concealed from public view or made compatible with the architecture of the surrounding structures or placed underground. The shelter or cabinet must be regularly maintained.**

Recommended conditions of approval require painting and texturing the antenna, per Planning Commission direction, to match the appearance of the wooden utility pole and power line posts.

**3. Macro Facilities may exceed the height limitation specified for all zones but may not exceed fifteen (15) feet above the roof line or parapet. Placement of an antenna on a nonconforming structure shall not be considered to be an expansion of the nonconforming structure.**

This standard is inapplicable because the proposal does not involve attachment to a roofed structure.

**4. Ground post mounted Macro Facilities must not exceed seventeen (17) feet to the top of the antenna.**

This standard is inapplicable because the proposal does not involve ground post mounting.

**5. The applicant shall submit written documentation demonstrating that the emissions from the proposed project are within the limits set by the Federal Communications Commission.**

This standard is met by the proposal; a satisfactory emissions report has been submitted and is attached to this report (Attachment F).

**17.128.110 Site location preferences.**

**New wireless facilities shall generally be located on the following properties or facilities in order of preference:**

- A. Co-located on an existing structure or facility with existing wireless antennas.**
- B. City-owned properties or other public or quasi-public facilities.**
- C. Existing commercial or industrial structures in Nonresidential Zones (excluding all HBX Zones and the D-CE-3 and D-CE-4 Zones).**
- D. Existing commercial or industrial structures in Residential Zones, HBX Zones, or the DCE-3 or D-CE-4 Zones.**
- E. Other Nonresidential uses in Residential Zones, HBX Zones, or the D-CE-3 or D-CE-4 Zones.**
- F. Residential uses in Nonresidential Zones (excluding all HBX Zones and the D-CE-3 and D-CE-4 Zones).**
- G. Residential uses in Residential Zones, HBX Zones, or the D-CE-3 or D-CE-4 Zones.**

A site alternatives analysis is not required because the proposal conforms to 'B' as it would be located on a quasi-public facility (utility pole with power lines and City light). Nonetheless, the applicant has submitted an analysis which is attached to this report (Attachment E).

**17.128.120 Site design preferences.**

**New wireless facilities shall generally be designed in the following order of preference:**

- A. Building or structure mounted antennas completely concealed from view.**
- B. Building or structure mounted antennas set back from roof edge, not visible from public right-of-way.**
- C. Building or structure mounted antennas below roof line (facade mount, pole mount) visible from public right-of-way, painted to match existing structure.**
- D. Building or structure mounted antennas above roof line visible from public right-of-way.**
- E. Monopoles.**
- F. Towers.**

**Facilities designed to meet an A or B ranked preference do not require a site design alternatives analysis. Facilities designed to meet a C through F ranked preference, inclusive, must submit a site design alternatives analysis as part of the required application materials. A site design alternatives analysis shall, at a minimum, consist of: a. Written evidence indicating why each such higher preference design alternative cannot be used. Such evidence shall be in sufficient detail that independent verification could be obtained if required by the City of Oakland Zoning Manager. Evidence should indicate if the reason an alternative was rejected was technical (e.g. incorrect height, interference from existing RF sources, inability to cover required area) or for other concerns (e.g. inability to provide utilities, construction or structural impediments).**

The proposal most closely conforms to 'C' (Building or structure mounted antennas below roof line (facade mount, pole mount) visible from public right-of-way, painted to match existing structure), and the applicant has submitted a satisfactory site design alternatives analysis (Attachment E).

**17.128.130 Radio frequency emissions standards.**

**The applicant for all wireless facilities, including requests for modifications to existing facilities, shall submit the following verifications:**

- a. With the initial application, a RF emissions report, prepared by a licensed professional engineer or other expert, indicating that the proposed site will operate within the current acceptable thresholds as established by the Federal government or any such agency who may be subsequently authorized to establish such standards.**
- b. Prior to commencement of construction, a RF emissions report indicating the baseline RF emissions condition at the proposed site.**
- c. Prior to final building permit sign off, an RF emissions report indicating that the site is actually operating within the acceptable thresholds as established by the Federal government or any such agency who may be subsequently authorized to establish such standards.**

A satisfactory report is attached to this report (Attachment F).

**Analysis**

The proposed site design would not be situated on a historic pole or structure and would not create a view obstruction. The utility pole is existing and no decorative poles are located in this area. Staff, therefore, finds the proposal to provide an essential service with a least-intrusive possible design. Draft conditions of approval stipulate that the components be painted and textured to match the pole in appearance for camouflaging.

In conclusion, staff recommends approval subject to recommended Conditions of Approval.

**RECOMMENDATIONS:**

1. Affirm staff's environmental determination.
2. Approve the Regular Design Review subject to the attached Findings and Conditions of Approval.

Prepared by:

  
MARILU GARCIA  
Planner I

Reviewed by:

  
ROBERT MERKAMP  
Acting Zoning Manager

Approved for forwarding to the Planning Commission:

  
DARIN RANELLETTI, Deputy Director  
Bureau of Planning

**ATTACHMENTS:**

- A. Findings
- B. Conditions of Approval
- C. Plans
- D. Applicant's Photo-Simulations
- E. Site Alternatives Analysis/Site Design Alternatives Analysis
- F. RF Emissions Report by Hammett & Edison, Inc.
- G. CPUC Compliance Letter
- H. Applicant's Proof of Public Notification Posting



**ATTACHMENT A: FINDINGS**

This proposal meets the required findings under Regular Design Review Criteria for Nonresidential Facilities (OMC Sec. 17.136.050(B)) and Telecommunications Regulations/Design Review Criteria for Macro Telecommunications Facilities (OMC Sec. 17.128.070(B)), as set forth below. Required findings are shown in **bold type**; explanations as to why these findings can be made are in normal type.

**REGULAR DESIGN REVIEW CRITERIA FOR NON-RESIDENTIAL FACILITIES (OMC SEC. 17.136.050(B))**

**1. That the proposed design will create a building or set of buildings that are well related to the surrounding area in their setting, scale, bulk, height, materials, and textures:**

The attachment of a small antenna and equipment to a non-historic utility pole, painted and texturized to match the pole and power line posts in appearance for camouflaging, will be the least intrusive design. The antennas will project over the street, away from the closest residence.

**2. That the proposed design will protect, preserve, or enhance desirable neighborhood characteristics;**

The proposal would not create a view obstruction since the pole is existing. The antennas would be placed above the roof line facing the street and not directly adjacent to a primary living space such as a living room or bedroom window, or be located on an historic structure.

**3. The project will provide a necessary function without negatively impacting surrounding opens pace and hillside residential properties.**

The proposal will enhance essential services in an urbanized neighborhood.

**4. That the proposed design will be sensitive to the topography and landscape.**

The proposal will not be ground mounted.

**5. That, if situated on a hill, the design and massing of the proposed building relates to the grade of the hill.**

This finding is inapplicable because the site is level.

**6. That the proposed design conforms in all significant respects with the Oakland General Plan and with any applicable design review guidelines or criteria, district plan, or development control map which have been adopted by the Planning Commission or City Council.**

The project is consistent with the following Objectives of the Oakland General Plan's Land Use & Transportation Element (adopted 1998):

Civic and Institutional Uses, Objective N2: Encourage adequate civic, institutional, and educational facilities located within Oakland, appropriately designed and sited to serve the community.

Infrastructure, Objective N12: Provide adequate infrastructure to meet the needs of Oakland's growing community.

The proposal to establish a new wireless telecommunications facility will not create functional issues for the area and the project possesses a satisfactory emissions report.

**TELECOMMUNICATIONS REGULATIONS/DESIGN REVIEW CRITERIA FOR MACRO TELECOMMUNICATIONS FACILITIES (OMC SEC. 17.128.070(B))**

**1. Antennas should be painted and/or textured to match the existing structure.**

The antenna will be painted and textured to match the power line posts in appearance for camouflaging will be the least intrusive design, as required by conditions of approval.

**2. Antennas mounted on architecturally significant structures or significant architectural detail of the building should be covered by appropriate casings which are manufactured to match existing architectural features found on the building.**

This finding is inapplicable because the antenna will not be mounted onto an architecturally significant structure but to an existing wooden utility pole.

**3. Where feasible, antennas can be placed directly above, below or incorporated with vertical design elements of a building to help in camouflaging.**

The antenna will be side mounted to the host utility pole below two posts hosting power lines.

**4. Equipment shelters or cabinets shall be screened from the public view by using landscaping, or materials and colors consistent with surrounding backdrop or placed underground or inside existing facilities or behind screening fences.**

Conditions of approval require painting and texturing to match the pole in appearance for camouflaging.

**5. Equipment shelters or cabinets shall be consistent with the general character of the area.**

Equipment will be attached to the utility pole with an unobtrusive design.

**6. For antennas attached to the roof, maintain a 1:1 ratio (example: ten (10) feet high antenna requires ten (10) feet setback from facade) for equipment setback; screen the antennas to match existing air conditioning units, stairs, or elevator towers; avoid placing roof mounted antennas in direct line with significant view corridors.**

This finding is inapplicable because the antenna would be attached to a pole and not to a roofed structure.

**7. That all reasonable means of reducing public access to the antennas and equipment has been made, including, but not limited to, placement in or on buildings or structures, fencing, anti-climbing measures and anti-tampering devices.**

The minimal clearance to the facility will be 6'-7".

**Attachment B: Conditions of Approval**

**Approved Use**

The project shall be constructed and operated in accordance with the authorized use as described in the approved application materials, **staff report** and the approved plans **dated June 21, 2017 and submitted August 16, 2017**, as amended by the following conditions of approval and mitigation measures, if applicable (“Conditions of Approval” or “Conditions”).

**2. Effective Date, Expiration, Extensions and Extinguishment**

This Approval shall become effective immediately, unless the Approval is appealable, in which case the Approval shall become effective in ten calendar days unless an appeal is filed. Unless a different termination date is prescribed, this Approval shall expire **two calendar years** from the Approval date, or from the date of the final decision in the event of an appeal, unless within such period all necessary permits for construction or alteration have been issued, or the authorized activities have commenced in the case of a permit not involving construction or alteration. Upon written request and payment of appropriate fees submitted no later than the expiration date of this Approval, the Director of City Planning or designee may grant a one-year extension of this date, with additional extensions subject to approval by the approving body. Expiration of any necessary building permit or other construction-related permit for this project may invalidate this Approval if said Approval has also expired. If litigation is filed challenging this Approval, or its implementation, then the time period stated above for obtaining necessary permits for construction or alteration and/or commencement of authorized activities is automatically extended for the duration of the litigation.

**3. Compliance with Other Requirements**

The project applicant shall comply with all other applicable federal, state, regional, and local laws/codes, requirements, regulations, and guidelines, including but not limited to those imposed by the City’s Bureau of Building, Fire Marshal, and Public Works Department. Compliance with other applicable requirements may require changes to the approved use and/or plans. These changes shall be processed in accordance with the procedures contained in Condition #4.

**4. Minor and Major Changes**

- a. Minor changes to the approved project, plans, Conditions, facilities, or use may be approved administratively by the Director of City Planning.
- b. Major changes to the approved project, plans, Conditions, facilities, or use shall be reviewed by the Director of City Planning to determine whether such changes require submittal and approval of a revision to the Approval by the original approving body or a new independent permit/approval. Major revisions shall be reviewed in accordance with the procedures required for the original permit/approval. A new independent permit/approval shall be reviewed in accordance with the procedures required for the new permit/approval.

**5. Compliance with Conditions of Approval**

- a. The project applicant and property owner, including successors, (collectively referred to hereafter as the “project applicant” or “applicant”) shall be responsible for compliance with all the Conditions of Approval and any recommendations contained in any submitted and approved technical report at his/her sole cost and expense, subject to review and approval by the City of Oakland.
- b. The City of Oakland reserves the right at any time during construction to require certification by a licensed professional at the project applicant’s expense that the as-built project

conforms to all applicable requirements, including but not limited to, approved maximum heights and minimum setbacks. Failure to construct the project in accordance with the Approval may result in remedial reconstruction, permit revocation, permit modification, stop work, permit suspension, or other corrective action.

- c. Violation of any term, Condition, or project description relating to the Approval is unlawful, prohibited, and a violation of the Oakland Municipal Code. The City of Oakland reserves the right to initiate civil and/or criminal enforcement and/or abatement proceedings, or after notice and public hearing, to revoke the Approval or alter these Conditions if it is found that there is violation of any of the Conditions or the provisions of the Planning Code or Municipal Code, or the project operates as or causes a public nuisance. This provision is not intended to, nor does it, limit in any manner whatsoever the ability of the City to take appropriate enforcement actions. The project applicant shall be responsible for paying fees in accordance with the City's Master Fee Schedule for inspections conducted by the City or a City-designated third-party to investigate alleged violations of the Approval or Conditions.

#### **6. Signed Copy of the Approval/Conditions**

A copy of the Approval letter and Conditions shall be signed by the project applicant, attached to each set of permit plans submitted to the appropriate City agency for the project, and made available for review at the project job site at all times.

#### **7. Blight/Nuisances**

The project site shall be kept in a blight/nuisance-free condition. Any existing blight or nuisance shall be abated within 60 days of approval, unless an earlier date is specified elsewhere.

#### **8. Indemnification**

- a. To the maximum extent permitted by law, the project applicant shall defend (with counsel acceptable to the City), indemnify, and hold harmless the City of Oakland, the Oakland City Council, the Oakland Redevelopment Successor Agency, the Oakland City Planning Commission, and their respective agents, officers, employees, and volunteers (hereafter collectively called "City") from any liability, damages, claim, judgment, loss (direct or indirect), action, causes of action, or proceeding (including legal costs, attorneys' fees, expert witness or consultant fees, City Attorney or staff time, expenses or costs) (collectively called "Action") against the City to attack, set aside, void or annul this Approval or implementation of this Approval. The City may elect, in its sole discretion, to participate in the defense of said Action and the project applicant shall reimburse the City for its reasonable legal costs and attorneys' fees.
- b. Within ten (10) calendar days of the filing of any Action as specified in subsection (a) above, the project applicant shall execute a Joint Defense Letter of Agreement with the City, acceptable to the Office of the City Attorney, which memorializes the above obligations. These obligations and the Joint Defense Letter of Agreement shall survive termination, extinguishment, or invalidation of the Approval. Failure to timely execute the Letter of Agreement does not relieve the project applicant of any of the obligations contained in this Condition or other requirements or Conditions of Approval that may be imposed by the City.

#### **9. Severability**

The Approval would not have been granted but for the applicability and validity of each and every one of the specified Conditions, and if one or more of such Conditions is found to be invalid by a

court of competent jurisdiction this Approval would not have been granted without requiring other valid Conditions consistent with achieving the same purpose and intent of such Approval.

#### **10. Job Site Plans**

*Ongoing throughout demolition, grading, and/or construction*

At least one (1) copy of the stamped approved plans, along with the Approval Letter and Conditions of Approval, shall be available for review at the job site at all times.

#### **11. Special Inspector/Inspections, Independent Technical Review, Project Coordination and Monitoring**

The project applicant may be required to cover the full costs of independent third-party technical review and City monitoring and inspection, including without limitation, special inspector(s)/inspection(s) during times of extensive or specialized plan-check review or construction, and inspections of potential violations of the Conditions of Approval. The project applicant shall establish a deposit with the Bureau of Building, if directed by the Building Official, Director of City Planning, or designee, prior to the issuance of a construction-related permit and on an ongoing as-needed basis.

#### **12. Public Improvements**

The project applicant shall obtain all necessary permits/approvals, such as encroachment permits, obstruction permits, curb/gutter/sidewalk permits, and public improvement ("p-job") permits from the City for work in the public right-of-way, including but not limited to, streets, curbs, gutters, sidewalks, utilities, and fire hydrants. Prior to any work in the public right-of-way, the applicant shall submit plans for review and approval by the Bureau of Planning, the Bureau of Building, and other City departments as required. Public improvements shall be designed and installed to the satisfaction of the City.

#### **13. Construction Days/Hours**

Requirement: The project applicant shall comply with the following restrictions concerning construction days and hours:

- a. Construction activities are limited to between 7:00 a.m. and 7:00 p.m. Monday through Friday, except that pier drilling and/or other extreme noise generating activities greater than 90 dBA shall be limited to between 8:00 a.m. and 4:00 p.m.
- b. Construction activities are limited to between 9:00 a.m. and 5:00 p.m. on Saturday. In residential zones and within 300 feet of a residential zone, construction activities are allowed from 9:00 a.m. to 5:00 p.m. only within the interior of the building with the doors and windows closed. No pier drilling or other extreme noise generating activities greater than 90 dBA are allowed on Saturday.
- c. No construction is allowed on Sunday or federal holidays.

Construction activities include, but are not limited to, truck idling, moving equipment (including trucks, elevators, etc.) or materials, deliveries, and construction meetings held on-site in a non-enclosed area.

Any construction activity proposed outside of the above days and hours for special activities (such as concrete pouring which may require more continuous amounts of time) shall be evaluated on a case-by-case basis by the City, with criteria including the urgency/emergency nature of the work, the proximity of residential or other sensitive uses, and a consideration of nearby residents'/occupants' preferences. The project applicant shall notify property owners and occupants located within 300 feet at least 14 calendar days prior to construction activity proposed outside of

the above days/hours. When submitting a request to the City to allow construction activity outside of the above days/hours, the project applicant shall submit information concerning the type and duration of proposed construction activity and the draft public notice for City review and approval prior to distribution of the public notice.

When Required: During construction

Initial Approval: N/A

Monitoring/Inspection: Bureau of Building

#### **PROJECT-SPECIFIC CONDITIONS**

##### **14. Emissions Report**

Requirement: A RF emissions report shall be submitted to the Planning Bureau indicating that the site is actually operating within the acceptable thresholds as established by the Federal government or any such agency who may be subsequently authorized to establish such standards.

Requirement: Prior to a final inspection

When Required: Prior to final building permit inspection sign-off

Initial Approval: N/A

Monitoring/Inspection: N/A

##### **15. Camouflage**

Requirement: The antenna shall be painted, texturized, and maintained matte silver, and the equipment and any other accessory items including cables matte brown, to better camouflage the facility to the utility pole and attached power line posts.

When Required: Prior to a final inspection

Initial Approval: N/A

Monitoring/Inspection: Bureau of Building

##### **16. Operational**

Requirement: Noise levels from the activity, property, or any mechanical equipment on site shall comply with the performance standards of Section 17.120 of the Oakland Planning Code and Section 8.18 of the Oakland Municipal Code. If noise levels exceed these standards, the activity causing the noise shall be abated until appropriate noise reduction measures have been installed and compliance verified by the Planning and Zoning Division and Building Services.

When Required: Ongoing

Initial Approval: N/A

Monitoring/Inspection: Bureau of Building

##### **17. Possible District Undergrounding PG&E Pole**

Requirement: Should the PG &E utility pole be permanently removed for purposes of district undergrounding or otherwise, the telecommunications facility can only be re-established by applying for and receiving approval of a new application to the Oakland Planning Bureau as required by the regulations.

When Required: Ongoing

Initial Approval: N/A

Monitoring/Inspection: N/A

**18. Graffiti Control Requirement:**

- a. During construction and operation of the project, the project applicant shall incorporate best management practices reasonably related to the control of graffiti and/or the mitigation of the impacts of graffiti. Such best management practices may include, without limitation:
- b. The project applicant shall remove graffiti by appropriate means within seventy-two (72) hours. Appropriate means include the following:
  - i. Removal through scrubbing, washing, sanding, and/or scraping (or similar method) without damaging the surface and without discharging wash water or cleaning detergents into the City storm drain system.
  - ii. For galvanized poles, covering with new paint to match the color of the surrounding surface.
  - iii. Replace pole numbers.

When Required: Ongoing

Initial Approval: N/A

Monitoring/Inspection: Bureau of Building

# NW-CA-DTOAKLAN 07404

ADJACENT TO (IN PROW)  
2701 LOGAN STREET  
OAKLAND, CA 94601

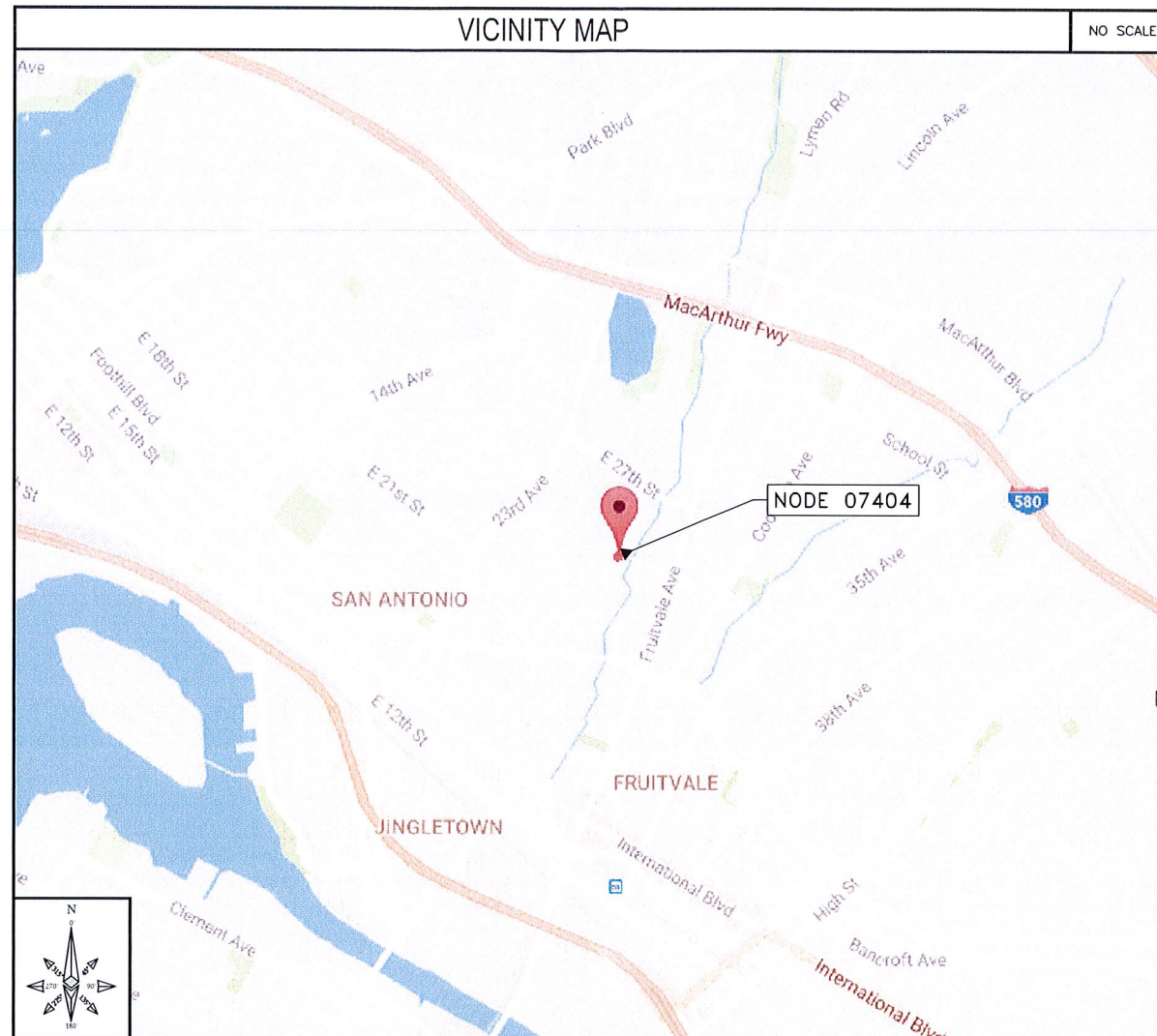
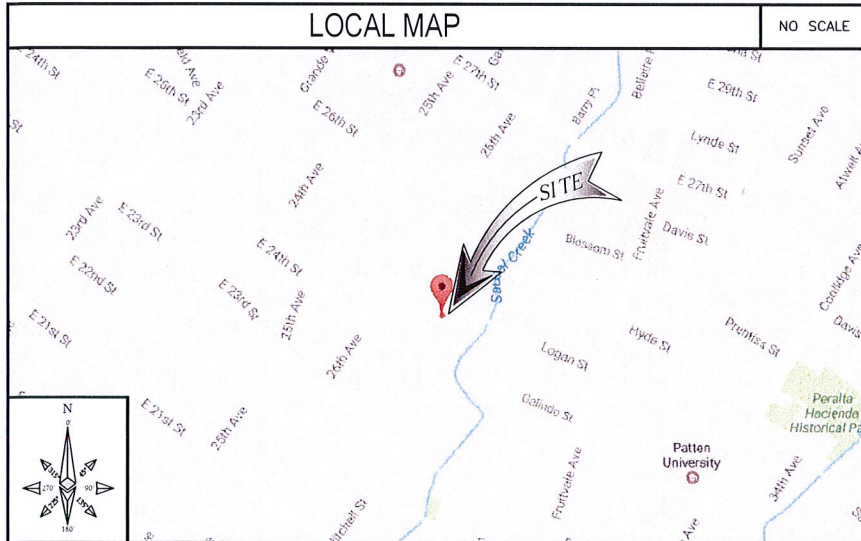

### CODE COMPLIANCE

ALL WORK AND MATERIALS SHALL BE PERFORMED AND INSTALLED IN ACCORDANCE WITH THE CURRENT EDITIONS OF THE FOLLOWING CODES AS ADOPTED BY THE LOCAL GOVERNING AUTHORITIES (AS APPLICABLE). NOTHING IN THESE PLANS IS TO BE CONSTRUCTED TO PERMIT WORK NOT CONFORMING TO THESE CODES.

- 1: IBC - 2012
- 2: CALIFORNIA BUILDING STANDARDS CODE - 2013
- 3: CALIFORNIA GENERAL ORDER 95
- 4: CALIFORNIA MECHANICAL CODE 2013
- 5: CALIFORNIA PLUMBING CODE 2013
- 6: CALIFORNIA ELECTRICAL CODE 2013
- 7: CITY AND/OR COUNTY ORDINANCES
- 8: 2012 INTERNATIONAL FIRE CODE
- 9: BUILDING OFFICIALS AND CODE ADMINISTRATORS (BOCA)  
\*EFFECTIVE UNTIL JANUARY 1ST, 2017

### PROJECT DESCRIPTION

THESE DRAWINGS DEPICT THE INSTALLATION OF A WIRELESS TELECOMMUNICATIONS NODE IN THE PUBLIC RIGHT OF WAY. HARDWARE AND ANCILLARY EQUIPMENT TO BE INSTALLED AS DESCRIBED HEREIN.

### GENERAL PROJECT NOTES

1. PRIOR TO SUBMITTING A BID, THE CONTRACTOR SHALL FAMILIARIZE HIMSELF/HERSELF WITH THE SCOPE OF WORK AND ALL CONDITIONS AFFECTING THE NEW PROJECT.
2. CONTRACTOR SHALL VERIFY ALL FIELD CONDITIONS AND DIMENSIONS OF THE JOB SITE AND CONFIRM THAT WORK AS INDICATED ON THESE CONSTRUCTION DOCUMENTS CAN BE ACCOMPLISHED AS SHOWN PRIOR TO COMMENCEMENT OF ANY WORK.
3. ALL FIELD MODIFICATIONS BEFORE, DURING OR AFTER CONSTRUCTION SHALL BE APPROVED IN WRITING BY AN EXTENET SYSTEMS REPRESENTATIVE.
4. INSTALL ALL EQUIPMENT AND MATERIALS PER THE MANUFACTURER'S RECOMMENDATIONS, UNLESS INDICATED OTHERWISE.
5. NOTIFY EXTENET SYSTEMS, IN WRITING, OF ANY MAJOR DISCREPANCIES REGARDING THE CONTRACT DOCUMENTS, EXISTING CONDITIONS, AND DESIGN INTENT. THE CONTRACTOR SHALL BE RESPONSIBLE FOR OBTAINING CLARIFICATIONS FROM AN EXTENET SYSTEMS REPRESENTATIVE, AND ADJUSTING THE BID ACCORDINGLY.
6. CONTRACTOR SHALL BE SOLELY RESPONSIBLE FOR ALL CONSTRUCTION MEANS, METHODS, TECHNIQUES, SEQUENCES AND PROCEDURES OF THE WORK UNDER THE CONTRACT.
7. CONTRACTOR SHALL PROTECT ALL EXISTING IMPROVEMENTS AND FINISHES THAT ARE TO REMAIN. CONTRACTOR SHALL REPAIR ANY DAMAGE THAT MAY OCCUR DURING THE CONSTRUCTION TO THE SATISFACTION OF AN EXTENET SYSTEMS REPRESENTATIVE.
8. CONTRACTOR PLANS TO ILLUSTRATE THE AS-BUILT CONDITION OF THE SITE. FOLLOWING THE FINAL INSPECTION BY EXTENET, THE CONTRACTOR SHALL PROVIDE EXTENET SYSTEMS WITH ONE COPY OF ALL RED-LINED DRAWINGS.
9. VERIFY ALL FINAL EQUIPMENT WITH AN EXTENET SYSTEMS REPRESENTATIVE. ALL EQUIPMENT LAYOUT, SPECS, PERFORMANCE INSTALLATION AND THEIR FINAL LOCATION ARE TO BE APPROVED BY EXTENET SYSTEMS. THE CONTRACTOR SHALL BE RESPONSIBLE FOR COORDINATING HIS/HER WORK WITH THE WORK AND CLEARANCES REQUIRED BY OTHERS RELATED TO SAID INSTALLATIONS.

INTERNAL REVIEW

CONSTRUCTION SIGNATURE	DATE
RF SIGNATURE	DATE
REAL ESTATE SIGNATURE	DATE

BLACK & VEATCH CORPORATION  
2999 OAK ROAD  
SUITE 490  
WALNUT CREEK, CA 94597

THESE DRAWINGS ARE COPYRIGHTED AND ARE THE PROPERTY OF BLACK & VEATCH; PRODUCED SOLELY FOR THE USE OF OUR CLIENT. ANY REPRODUCTION OR USE OF THE INFORMATION CONTAINED WITHIN SAID DRAWINGS IS PROHIBITED WITHOUT WRITTEN CONSENT BY BLACK & VEATCH.

PROJECT NO.	DRAWN BY	CHECKED BY
192417.6171	YJG	LW

REV	DATE	DESCRIPTION
A	06/21/17	ISSUED FOR REVIEW

IT IS A VIOLATION OF LAW FOR ANY PERSON, UNLESS THEY ARE ACTING UNDER THE DIRECTION OF A LICENSED PROFESSIONAL ENGINEER, TO ALTER THIS DOCUMENT.

EXTENET SYSTEMS (CA) LLC  
2000 CROW CANYON PLACE  
SUITE 210  
SAN RAMON, CA 94583

SITE ADDRESS  
07404  
ADJACENT TO (IN PROW)  
2701 LOGAN STREET  
OAKLAND, CA 94601

SHEET TITLE  
TITLE SHEET

SHEET NUMBER  
**T-1**

### SHEET INDEX

SHEET NO:	SHEET TITLE
T-1	TITLE SHEET
GN-1	GENERAL NOTES AND LEGEND
Z-1	OVERALL SITE PLAN
Z-2	UTILITY POLE ELEVATIONS
Z-2.1	RISER DETAILS
Z-3	EQUIPMENT DETAILS
Z-4	EQUIPMENT DETAILS

## Attachment C

IF USING 11"X17" PLOT, DRAWINGS WILL BE HALF SCALE

SUBCONTRACTOR SHALL VERIFY ALL PLANS & EXISTING DIMENSIONS & CONDITIONS ON THE JOB SITE & SHALL IMMEDIATELY NOTIFY THE ENGINEER IN WRITING OF ANY DISCREPANCIES BEFORE PROCEEDING WITH THE WORK OR BE RESPONSIBLE FOR SAME

### PROJECT INFORMATION

#### POLE OWNER

OWNER: EXTENET SYSTEMS CALIFORNIA, LLC.  
ADDRESS: 2000 CROW CANYON PLACE, SUITE 210, SAN RAMON, CA 94583  
PHONE: -

#### APPLICANT

COMPANY: EXTENET SYSTEMS CALIFORNIA, LLC.  
CONTACT: CHARLES LINDSAY  
ADDRESS: 2000 CROW CANYON PLACE, SUITE 210, SAN RAMON, CA 94583  
PHONE: (510) 910-7787  
E-MAIL: CLINDSAY@EXTENETSYSTEMS.COM

#### AGENT

COMPANY: BLACK & VEATCH  
CONTACT: ANA GOMEZ-ABARCA, EXECUTION MANAGER, TELECOM  
ADDRESS: 2999 OAK ROAD, SUITE 490, WALNUT CREEK, CA 94597  
PHONE: (913) 458-9148 O, (925) 949-5902 F  
EMAIL: GOMEZABARCAA@BV.COM

#### ENGINEER

COMPANY: BLACK & VEATCH  
ENGINEER: AARON EVANS  
PHONE: (952) 896-0751  
E-MAIL: EVANSRA@BV.COM

#### PROJECT DATA

LATITUDE: 37.788543658'  
LONGITUDE: -122.224047753'  
POLE #: 110141793  
ELEVATION: 104' AMSL  
ZONING JURISDICTION: CITY OF OAKLAND  
ZONING DISTRICT: RM-3  
NEAREST A.P.N.: 26-763-1  
OCCUPANCY: U, UNMANNED  
CONSTRUCTION TYPE: ATTACHMENTS TO A WOOD UTILITY POLE  
TITLE 24 REQUIREMENTS: FACILITY IS UNMANNED AND NOT FOR HUMAN HABITATION. THIS PROJECT IS EXEMPT.

UNDERGROUND SERVICE ALERT  
UTILITIES PROTECTION CENTER, INC.  
811  
48 HOURS BEFORE YOU DIG



**GENERAL NOTES**

- THESE NOTES SHALL BE CONSIDERED A PART OF THE WRITTEN SPECIFICATIONS, CONTRACT AND CONSTRUCTION DOCUMENTS.
- THE WORK SHALL INCLUDE FURNISHING MATERIALS, EQUIPMENT, APPURTENANCES, AND LABOR NECESSARY TO COMPLETE ALL INSTALLATIONS AS INDICATED ON THESE PLANS AND IN THE CONTRACT DOCUMENTS.
- PRIOR TO THE SUBMISSION OF BIDS, THE CONTRACTOR(S) SHALL VISIT THE JOB SITE(S) AND BE RESPONSIBLE FOR ALL CONTRACT DOCUMENTS, FIELD CONDITIONS AND DIMENSIONS, AND CONFIRM THAT THE WORK MAY BE ACCOMPLISHED PER THE CONTRACT DOCUMENTS. ANY DISCREPANCIES ARE TO BE BROUGHT TO THE ATTENTION OF THE IMPLEMENTATION ENGINEER AND ARCHITECT/ENGINEER PRIOR TO BID SUBMITTAL.
- THE CONTRACTOR SHALL RECEIVE WRITTEN AUTHORIZATION TO PROCEED ON ANY WORK NOT CLEARLY DEFINED OR IDENTIFIED IN THE CONTRACT AND CONSTRUCTION DOCUMENTS BEFORE STARTING ANY WORK.
- ALL WORK PERFORMED AND MATERIALS INSTALLED SHALL BE IN STRICT ACCORDANCE WITH ALL APPLICABLE CODES, REGULATIONS, AND ORDINANCES, INCLUDING APPLICABLE MUNICIPAL AND UTILITY COMPANY SPECIFICATIONS.
- THE CONTRACTOR SHALL INSTALL ALL EQUIPMENT AND MATERIALS IN ACCORDANCE WITH MANUFACTURER RECOMMENDATIONS. IF THESE RECOMMENDATIONS ARE IN CONFLICT WITH THE CONTRACT AND CONSTRUCTION DOCUMENTS AND/OR APPLICABLE CODES OR REGULATIONS, REVIEW AND RESOLVE THE CONFLICT WITH DIRECTION FROM THE IMPLEMENTATION ENGINEER AND ARCHITECT/ENGINEER PRIOR TO PROCEEDING.
- THE CONTRACTOR SHALL BE SOLELY RESPONSIBLE FOR ALL CONSTRUCTION MEANS, METHODS, TECHNIQUES, SEQUENCES, AND PROCEDURES AND FOR COORDINATION OF ALL PORTIONS OF THE WORK UNDER THE CONTRACT INCLUDING CONTACT AND COORDINATION WITH THE IMPLEMENTATION ENGINEER AND WITH THE AUTHORIZED REPRESENTATIVE OF ANY OUTSIDE POLE OR PROPERTY OWNER.
- THE CONTRACTOR SHALL MAKE NECESSARY PROVISIONS TO PROTECT EXISTING IMPROVEMENTS, INCLUDING BUT NOT LIMITED TO PAVING, CURBS, VEGETATION, GALVANIZED SURFACE OR OTHER EXISTING ELEMENTS AND UPON COMPLETION OF THE WORK, REPAIR ANY DAMAGE THAT OCCURRED DURING CONSTRUCTION TO THE SATISFACTION OF EXTENET.
- CONTRACTOR IS TO KEEP THE GENERAL AREA CLEAN, HAZARD FREE, AND DISPOSE OF ALL DIRT, DEBRIS, RUBBISH, AND REMOVE EQUIPMENT NOT SPECIFIED AS REMAINING ON THE PROPERTY. LEAVE PREMISES IN CLEAN CONDITION DAILY.
- PLANS ARE INTENDED TO BE DIAGRAMMATIC ONLY AND SHOULD NOT BE SCALED UNLESS OTHERWISE NOTED. RELY ONLY ON ANNOTATED DIMENSIONS AND REQUEST INFORMATION IF ADDITIONAL DIMENSIONS ARE REQUIRED.
- THE EXISTENCE AND LOCATION OF UTILITIES AND OTHER AGENCY'S FACILITIES WERE OBTAINED BY A SEARCH OF AVAILABLE RECORDS. OTHER FACILITIES MAY EXIST. CONTRACTOR SHALL VERIFY LOCATIONS PRIOR TO START OF CONSTRUCTION AND USE EXTREME CARE AND PROTECTIVE MEASURES TO PREVENT DAMAGE TO THESE FACILITIES. CONTRACTOR IS RESPONSIBLE FOR THE PROTECTION OF UTILITIES OR OTHER AGENCY'S FACILITIES WITHIN THE LIMITS OF THE WORK, WHETHER THEY ARE IDENTIFIED IN THE CONTRACT DOCUMENTS OR NOT.
- THE CONTRACTOR SHALL NOTIFY UNDERGROUND SERVICE ALERT (800) 227-2600, AT LEAST TWO WORKING DAYS PRIOR TO THE START OF ANY EXCAVATION.

**DEFINITIONS**

- "TYPICAL" OR "TYP" MEANS THAT THIS ITEM IS SUBSTANTIALLY THE SAME ACROSS SIMILAR CONDITIONS. "TYP" SHALL BE UNDERSTOOD TO MEAN "TYPICAL WHERE OCCURS" AND SHALL NOT BE CONSIDERED AS WITHOUT EXCEPTION OR CONSIDERATION OF SPECIFIC CONDITIONS.
- "SIMILAR" MEANS COMPARABLE TO CHARACTERISTICS FOR THE CONDITION NOTED. VERIFY DIMENSIONS AND ORIENTATION ON PLAN.
- "AS REQUIRED" MEANS AS REQUIRED BY REGULATORY REQUIREMENTS, BY REFERENCED STANDARDS, BY EXISTING CONDITIONS, BY GENERALLY ACCEPTED CONSTRUCTION PRACTICE, OR BY THE CONTRACT DOCUMENTS.
- "ALIGN" MEANS ACCURATELY LOCATE FINISH FACES OF MATERIALS IN THE SAME PLANE.
- THE TERM "VERIFY" OR "V.I.F." SHALL BE UNDERSTOOD TO MEAN "VERIFY IN FIELD WITH ENGINEER" AND REQUIRES THAT THE CONTRACTOR CONFIRM INTENTION REGARDING NOTED CONDITION AND PROCEED ONLY AFTER RECEIVING DIRECTION.
- WHERE THE WORDS "OR EQUAL" OR WORDS OF SIMILAR INTENT FOLLOW A MATERIAL SPECIFICATION, THEY SHALL BE UNDERSTOOD TO REQUIRE SIGNED APPROVAL OF ANY DEVIATION TO SAID SPECIFICATION PRIOR TO CONTRACTOR'S ORDERING OR INSTALLATION OF SUCH PROPOSED EQUAL PRODUCT.
- FURNISH : SUPPLY ONLY, OTHERS TO INSTALL. INSTALL: INSTALL ITEMS FURNISHED BY OTHERS. PROVIDE: FURNISH AND INSTALL.

**FIELD WELDING NOTES:**

- WELDING TO BE PERFORMED BY AWS CERTIFIED WELDER FOR THE TYPE OF AND POSITION INDICATED. ALL WORK MUST BE IN CONFORMANCE WITH LATEST EDITION OF AWS D1.1.
- GRIND SURFACES TO BE WELDED WITH A SILICON CARBIDE WHEEL PRIOR TO WELDING TO REMOVE ALL GALVANIZING WHICH MAY OTHERWISE BE CONSUMED IN THE WELD METAL. APPLY ANTI-SPATTER COMPOUND AFTER GRINDING.
- WELDING TECHNIQUE MUST MINIMIZE TEMPERATURE RISE ON THE INSIDE SURFACE OF THE POLE AND ALSO VOLATILIZE ANY REMAINING ZINC WITHIN THE BASE METAL WITH MINIMUM SPATTER. USE AN E70 (LOW HYDROGEN) ELECTRODE. USE LARGEST DIAMETER ELECTRODE COMPATIBLE WITH WELDING POSITION AND MATERIAL THICKNESS. STRICTLY FOLLOW ALL MANUFACTURER'S INSTRUCTIONS FOR STORAGE AND USE OF ELECTRODES. AVOID REMOVING ELECTRODES FROM MANUFACTURER'S PACKAGING UNTIL READY FOR IMMEDIATE USE.
- WELDING MAY PRODUCE TOXIC FUMES. REFER TO ANSI STANDARD Z49.1 "SAFETY IN WELDING AND CUTTING" FOR PROPER PRECAUTIONS.
- UPON COMPLETION OF WELDING, APPLY GALV-A-STICK ZINC COATING TO ALL UNPROTECTED SURFACES. APPLY A SECOND LAYER OF COLD GALVANIZING SPRAY COMPOUND CONTAINING A MINIMUM ZINC CONTENT OF 95%. IF NECESSARY, APPLY A FINAL COAT OF COMPATIBLE PAINT TO MATCH SURROUNDING SURFACES.

**ANTENNA MOUNTING**

- DESIGN AND CONSTRUCTION OF ANTENNA SUPPORTS SHALL CONFORM TO CURRENT ANSI/TIA-222 OR APPLICABLE LOCAL CODES.
- ALL STEEL MATERIALS SHALL BE GALVANIZED AFTER FABRICATION IN ACCORDANCE WITH ASTM A123 "ZINC (HOT-DIP GALVANIZED) COATINGS ON IRON AND STEEL PRODUCTS", UNLESS NOTED OTHERWISE.
- ALL BOLTS, ANCHORS AND MISCELLANEOUS HARDWARE SHALL BE GALVANIZED IN ACCORDANCE WITH ASTM A153 "ZINC-COATING (HOT-DIP) ON IRON AND STEEL HARDWARE", UNLESS NOTED OTHERWISE.
- DAMAGED GALVANIZED SURFACES SHALL BE REPAIRED BY COLD GALVANIZING IN ACCORDANCE WITH ASTM A780.
- ALL ANTENNA MOUNTS SHALL BE INSTALLED WITH LOCK NUTS, DOUBLE NUTS AND SHALL BE TORQUED TO MANUFACTURER'S RECOMMENDATIONS.
- CONTRACTOR SHALL INSTALL ANTENNA PER MANUFACTURER'S RECOMMENDATION FOR INSTALLATION AND GROUNDING.
- PRIOR TO SETTING ANTENNA AZIMUTHS AND DOWNTILTS, ANTENNA CONTRACTOR SHALL CHECK THE ANTENNA MOUNT FOR TIGHTNESS AND ENSURE THAT THEY ARE PLUMB. ANTENNA AZIMUTHS SHALL BE SET FROM TRUE NORTH AND BE ORIENTED WITHIN +/- 5% AS DEFINED BY THE RFDS. ANTENNA DOWNTILTS SHALL BE WITHIN +/- 0.5% AS DEFINED BY THE RFDS.

**TORQUE REQUIREMENTS**

- ALL RF CONNECTIONS SHALL BE TIGHTENED BY A TORQUE WRENCH.
- ALL RF CONNECTIONS, GROUNDING HARDWARE AND ANTENNA HARDWARE SHALL HAVE A TORQUE MARK INSTALLED IN A CONTINUOUS STRAIGHT LINE FROM BOTH SIDES OF THE CONNECTION.
  - RF CONNECTION BOTH SIDES OF THE CONNECTOR.
  - GROUNDING AND ANTENNA HARDWARE ON THE NUT SIDE STARTING FROM THE THREADS TO THE SOLID SURFACE. EXAMPLE OF SOLID SURFACE: GROUND BAR, ANTENNA BRACKET METAL.
- ALL 8M ANTENNA HARDWARE SHALL BE TIGHTENED TO 9 LB-FT (12 NM).
- ALL 12M ANTENNA HARDWARE SHALL BE TIGHTENED TO 43 LB-FT (58 NM).
- ALL GROUNDING HARDWARE SHALL BE TIGHTENED UNTIL THE LOCK WASHER COLLAPSES AND THE GROUNDING HARDWARE IS NO LONGER LOOSE.
- ALL DIN TYPE CONNECTIONS SHALL BE TIGHTENED TO 18-22 LB-FT (24.4 - 29.8 NM).
- ALL N TYPE CONNECTIONS SHALL BE TIGHTENED TO 15-20 LB-IN (1.7 - 2.3 NM).

**ROW UTILITY POLE CONSTRUCTION NOTES**

- NO BOLT THREADS TO PROTRUDE MORE THAN 1-1/2" [.038M].
- FILL ALL HOLES LEFT IN POLE FROM REARRANGEMENT OF CLIMBERS.
- ALL CLIMB STEPS NEXT TO CONDUIT SHALL HAVE EXTENDED STEPS.
- CABLE NOT TO IMPEDE 15" [.381M] CLEAR SPACE OFF POLE FACE (12:00).
- 90 SHORT SWEEPS UNDER ANTENNA ARM. ALL CABLES MUST ONLY TRANSITION ON THE INSIDE OR BOTTOM OF ARMS (NO CABLE ON TOP OF ARMS).
- USE 90 CONNECTOR AT CABLE CONNECTION TO ANTENNAS.
- USE 1/2" [.013M] CABLE ON ANTENNAS UNLESS OTHERWISE SPECIFIED.
- FILL VOID AROUND CABLES AT CONDUIT OPENING WITH FOAM SEALANT TO PREVENT WATER INTRUSION.

**NODE SITE POWER SHUT DOWN PROCEDURES**

- FOR NON EMERGENCY/SCHEDULED POWER SHUT DOWN
  - CALL EXTENET SYSTEMS NOC (NETWORK OPERATIONS CENTER) (866)892-5327
  - 24 HOURS PRIOR TO SCHEDULED POWER SHUT OFF
  - PROVIDE THE FOLLOWING INFORMATION
    - NOC SITE NUMBER IDENTIFIED ON SITE NUMBERING STICKER
    - YOUR NAME AND REASON FOR POWER SHUTOFF
    - PROVIDE DURATION OF OUTAGE
  - UNLOCK DISCONNECT BOX, FLIP BOTH BREAKERS TO THE OFF POSITION
  - POWER SHUT OFF VERIFICATION WITH APPROVED PG&E PROCEDURES
  - NOTIFY EXTENET NOC UPON COMPLETION OF WORK
  - REINSTALL LOCK ON DISCONNECT BOX
- EMERGENCY POWER SHUT OFF
  - CALL EXTENET SYSTEMS NOC (NETWORK OPERATIONS CENTER) (866)892-5327
  - PROVIDE THE FOLLOWING INFORMATION
    - NOC SITE NUMBER IDENTIFIED ON SITE NUMBERING STICKER
    - YOUR NAME AND REASON FOR POWER SHUTOFF
    - PROVIDE DURATION OF OUTAGE
  - UNLOCK DISCONNECT BOX, FLIP BOTH BREAKERS TO THE OFF POSITION
  - POWER SHUT OFF VERIFICATION WITH APPROVED PG&E PROCEDURES
  - NOTIFY EXTENET NOC UPON COMPLETION OF WORK
  - REINSTALL LOCK ON DISCONNECT BOX

**LEGEND**

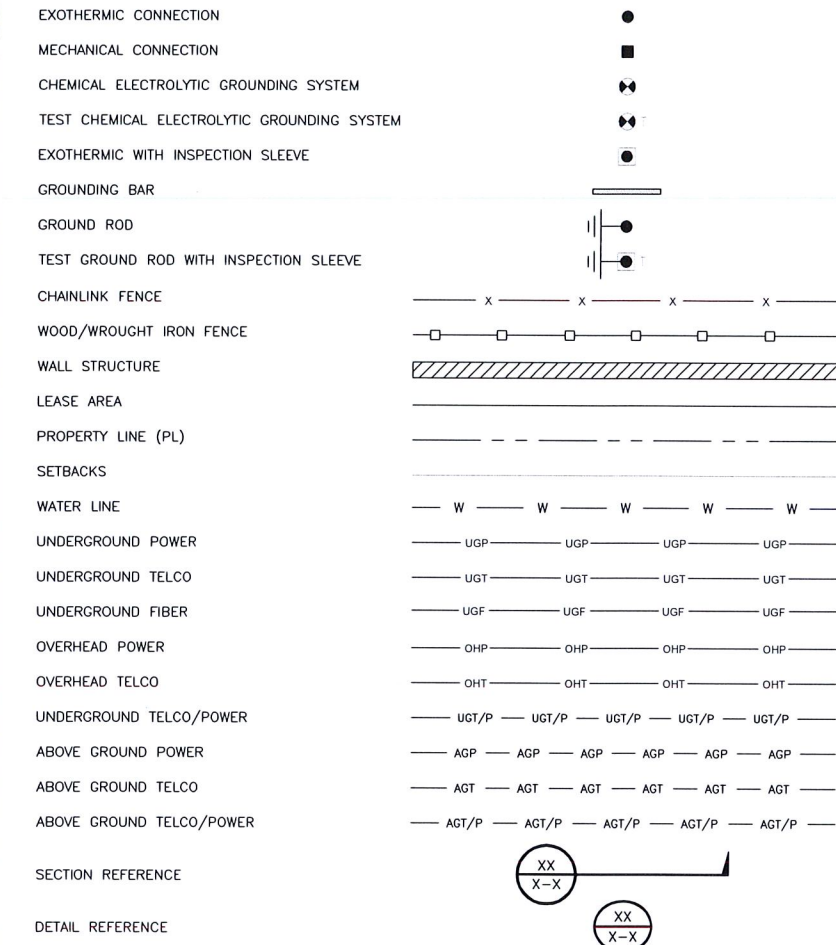

INTERNAL REVIEW	
CONSTRUCTION SIGNATURE	DATE
RF SIGNATURE	DATE
REAL ESTATE SIGNATURE	DATE

BLACK & VEATCH CORPORATION  
2999 OAK ROAD  
SUITE 490  
WALNUT CREEK, CA 94597

THESE DRAWINGS ARE COPYRIGHTED AND ARE THE PROPERTY OF BLACK & VEATCH. PRODUCED SOLELY FOR THE USE OF OUR CLIENT. ANY REPRODUCTION OR USE OF THE INFORMATION CONTAINED WITHIN SAID DRAWINGS IS PROHIBITED WITHOUT WRITTEN CONSENT BY BLACK & VEATCH.

PROJECT NO.	DRAWN BY	CHECKED BY
192417.6171	YJG	LW

A	06/21/17	ISSUED FOR REVIEW
REV	DATE	DESCRIPTION

IT IS A VIOLATION OF LAW FOR ANY PERSON, UNLESS THEY ARE ACTING UNDER THE DIRECTION OF A LICENSED PROFESSIONAL ENGINEER, TO ALTER THIS DOCUMENT.

EXTENET SYSTEMS (CA) LLC  
2000 CROW CANYON PLACE  
SUITE 210  
SAN RAMON, CA 94583

SITE ADDRESS  
07404  
ADJACENT TO (IN PROW)  
2701 LOGAN STREET  
OAKLAND, CA 94601

SHEET TITLE  
GENERAL NOTES  
AND LEGEND

SHEET NUMBER  
**GN-1**

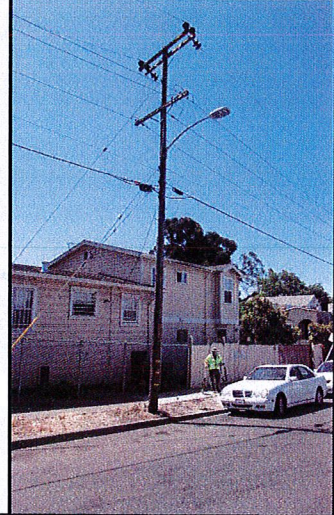
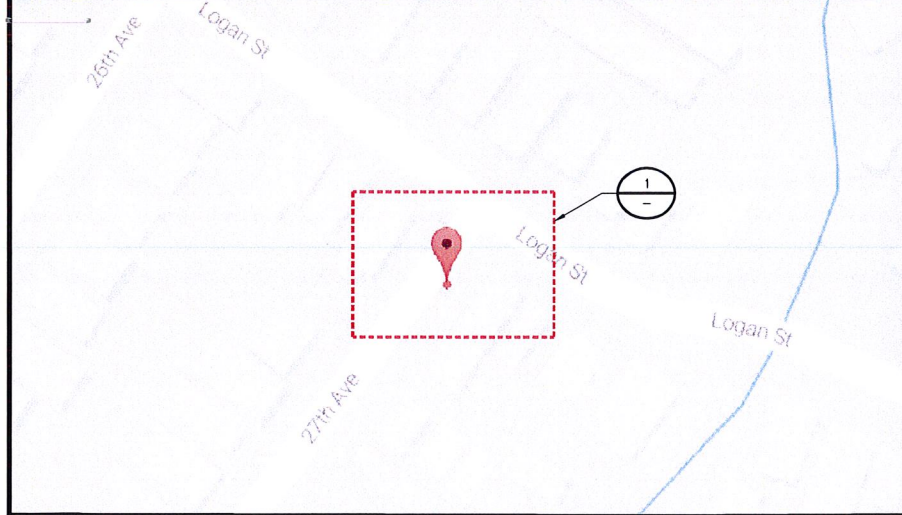

SITE PLAN MAP NO SCALE A SITE PHOTO B

A.P.N. 26-773-11

**THIS DRAWING IS NOT A SITE SURVEY**

THE PURPOSE OF THIS DRAWING IS TO SHOW HOW THE DEVELOPED SITE RELATES TO THE PARENT PARCEL AND ADJACENT PROPERTIES. R.O.W. MEASUREMENTS ARE APPROXIMATIONS.

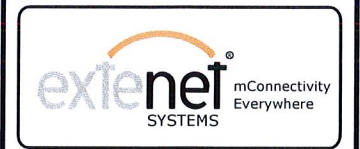
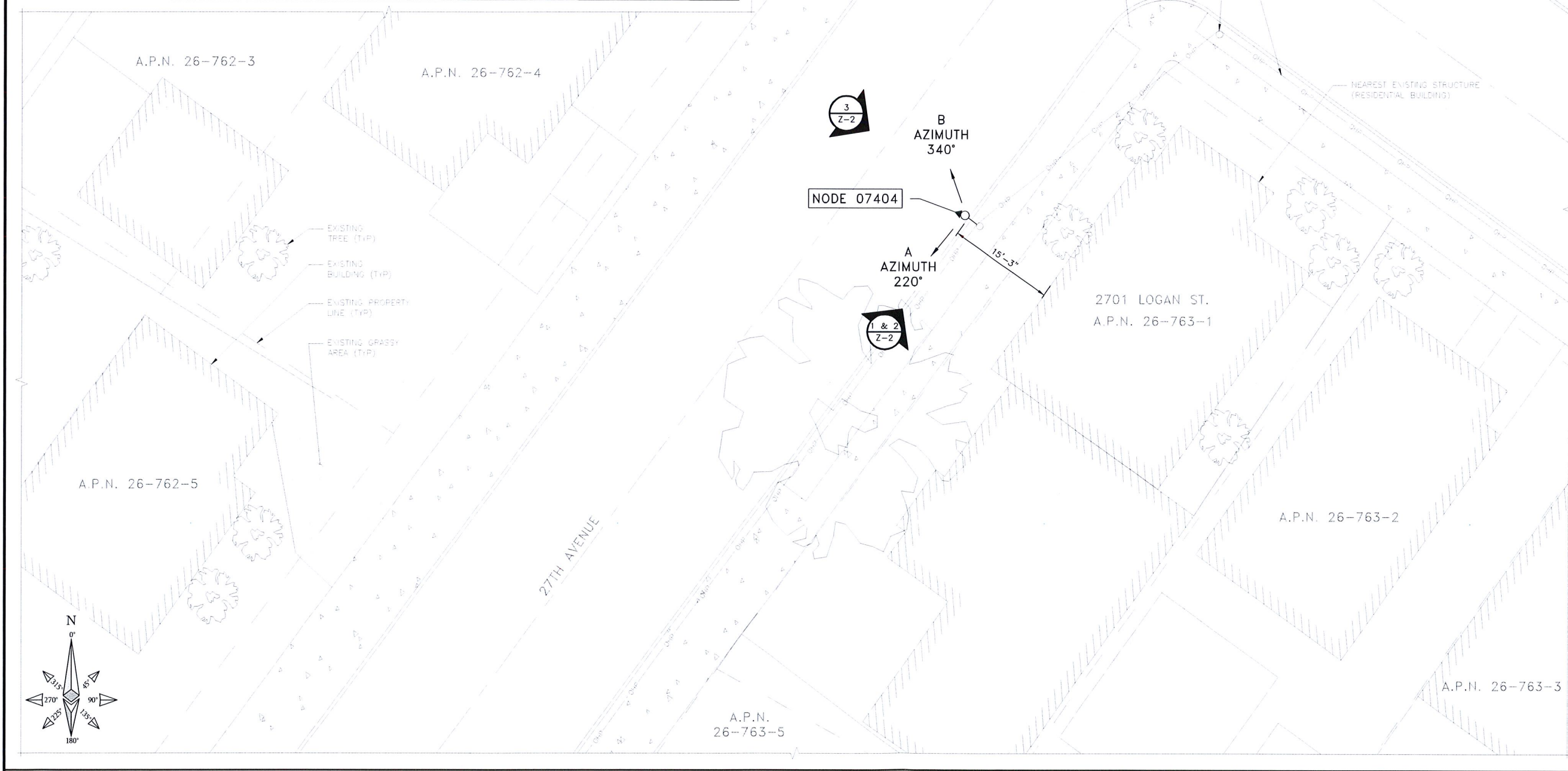

INTERNAL REVIEW	
CONSTRUCTION SIGNATURE	DATE
RF SIGNATURE	DATE
REAL ESTATE SIGNATURE	DATE

**BLACK & VEATCH**

BLACK & VEATCH CORPORATION  
2999 OAK ROAD  
SUITE 490  
WALNUT CREEK, CA 94597

THESE DRAWINGS ARE COPYRIGHTED AND ARE THE PROPERTY OF BLACK & VEATCH; PRODUCED SOLELY FOR THE USE OF OUR CLIENT. ANY REPRODUCTION OR USE OF THE INFORMATION CONTAINED WITHIN SAID DRAWINGS IS PROHIBITED WITHOUT WRITTEN CONSENT BY BLACK & VEATCH.

PROJECT NO.	DRAWN BY	CHECKED BY
192417.6171	YJG	LW

REV	DATE	DESCRIPTION
A	06/21/17	ISSUED FOR REVIEW

IT IS A VIOLATION OF LAW FOR ANY PERSON, UNLESS THEY ARE ACTING UNDER THE DIRECTION OF A LICENSED PROFESSIONAL ENGINEER, TO ALTER THIS DOCUMENT.

EXTENET SYSTEMS (CA) LLC  
2000 CROW CANYON PLACE  
SUITE 210  
SAN RAMON, CA 94583

SITE ADDRESS  
07404  
ADJACENT TO (IN PROW)  
2701 LOGAN STREET  
OAKLAND, CA 94601

SHEET TITLE  
OVERALL SITE PLAN

SHEET NUMBER  
**Z-1**

OVERALL SITE PLAN

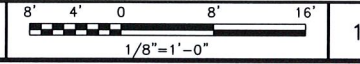

**NOTE \***

THESE DRAWINGS HAVE BEEN CREATED BASED ON THE ASSUMPTION THAT THE STRUCTURE HAS SUFFICIENT CAPACITY TO SUPPORT THE PROPOSED LOADING. IT IS THE RESPONSIBILITY OF THE POLE OWNER TO CONFIRM THAT THE PROPOSED LOADING IS WITHIN THE ORIGINAL DESIGN CAPACITY OF THE STRUCTURE.

**CARRIER MAKE-READY**

- CONTRACTOR TO INSTALL (2) ANTENNAS w/ ANCILLARY ELECTRONICS AND HARDWARE ON PROPOSED ANTENNA BRACKET MOUNT.
- CONTRACTOR TO INSTALL (2) RADIOS w/ ANCILLARY ELECTRONICS AND HARDWARE ON PROPOSED CHANNEL MOUNTS.
- CONTRACTOR TO INSTALL (1)-2" SCH. 80 PVC U-GUARD FOR COAX AND FIBER CABLES.
- CONTRACTOR TO INSTALL (1) RF SHUTDOWN ON PROPOSED CHANNEL MOUNTS.
- CONTRACTOR TO INSTALL (1) SMART METER.
- CONTRACTOR TO INSTALL (1)-2" SCH. 80 PVC U-GUARD WITH WEATHERHEAD FOR POWER.
- EXTENET APPROVED CONTRACTOR TO RELOCATE EXISTING COMM LINES FROM 21'-6" TO 23'-3" ON PROPOSED CROSS ARM.
- EXTENET APPROVED CONTRACTOR TO RELOCATE EXISTING SPAN GUY LINES FROM 23'-2" TO 23'-3" ON PROPOSED CROSS ARM.
- EXTENET APPROVED CONTRACTOR TO INSTALL (1) NEW FIBER OPTIC CABLE AT 23'-3" ON PROPOSED CROSS ARM.
- CONTRACTOR TO INSTALL REQUIRED RF SIGNAGE 3'-0" BELOW PROPOSED ANTENNA MOUNT.

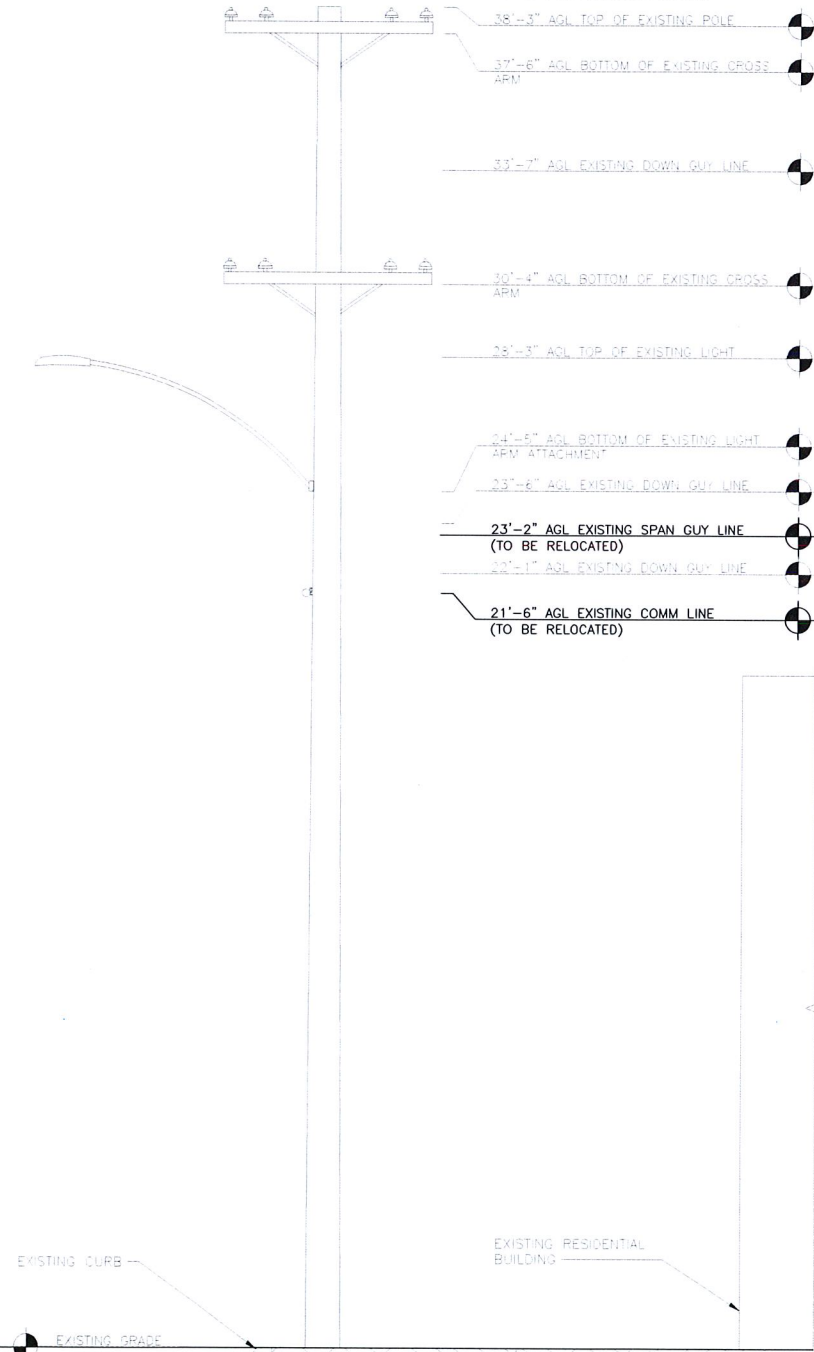

EXISTING SOUTHWEST ELEVATION

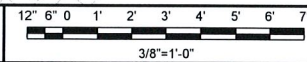

1

**NOTES**

- ALL PROPOSED/ANCILLARY EQUIPMENT TO BE PAINTED MESA BROWN TO MATCH EXISTING UTILITY POLE.
- DISTANCE FROM ANTENNA FACE TO NEAREST BUILDING (2701 LOGAN STREET). SEE SHEET Z-1 FOR ORIENTATION.
- ANTENNA SHROUD NOT ENTIRELY SHOWN FOR CLARITY.

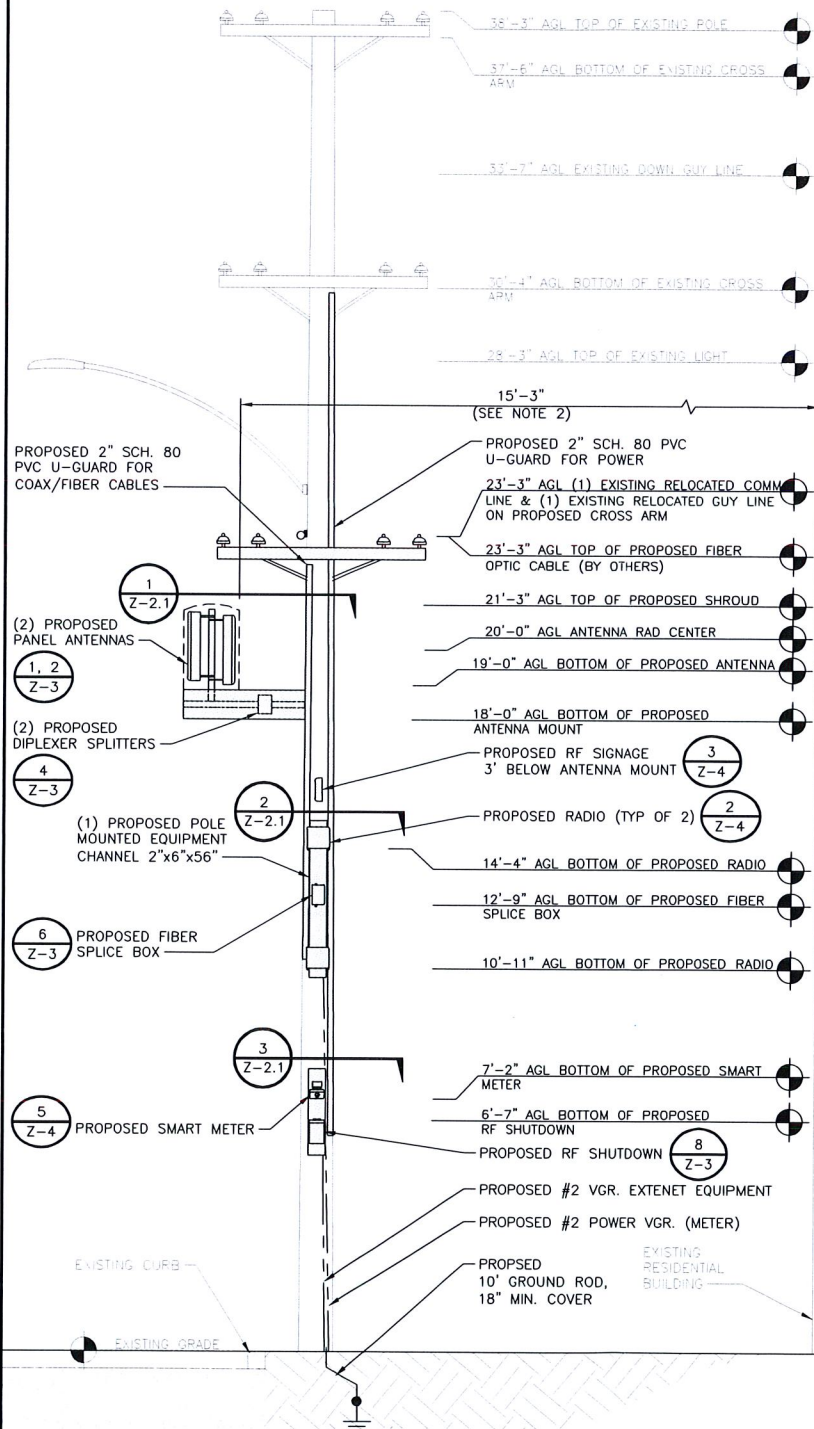

PROPOSED SOUTHWEST ELEVATION

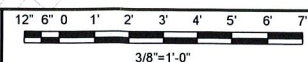

2

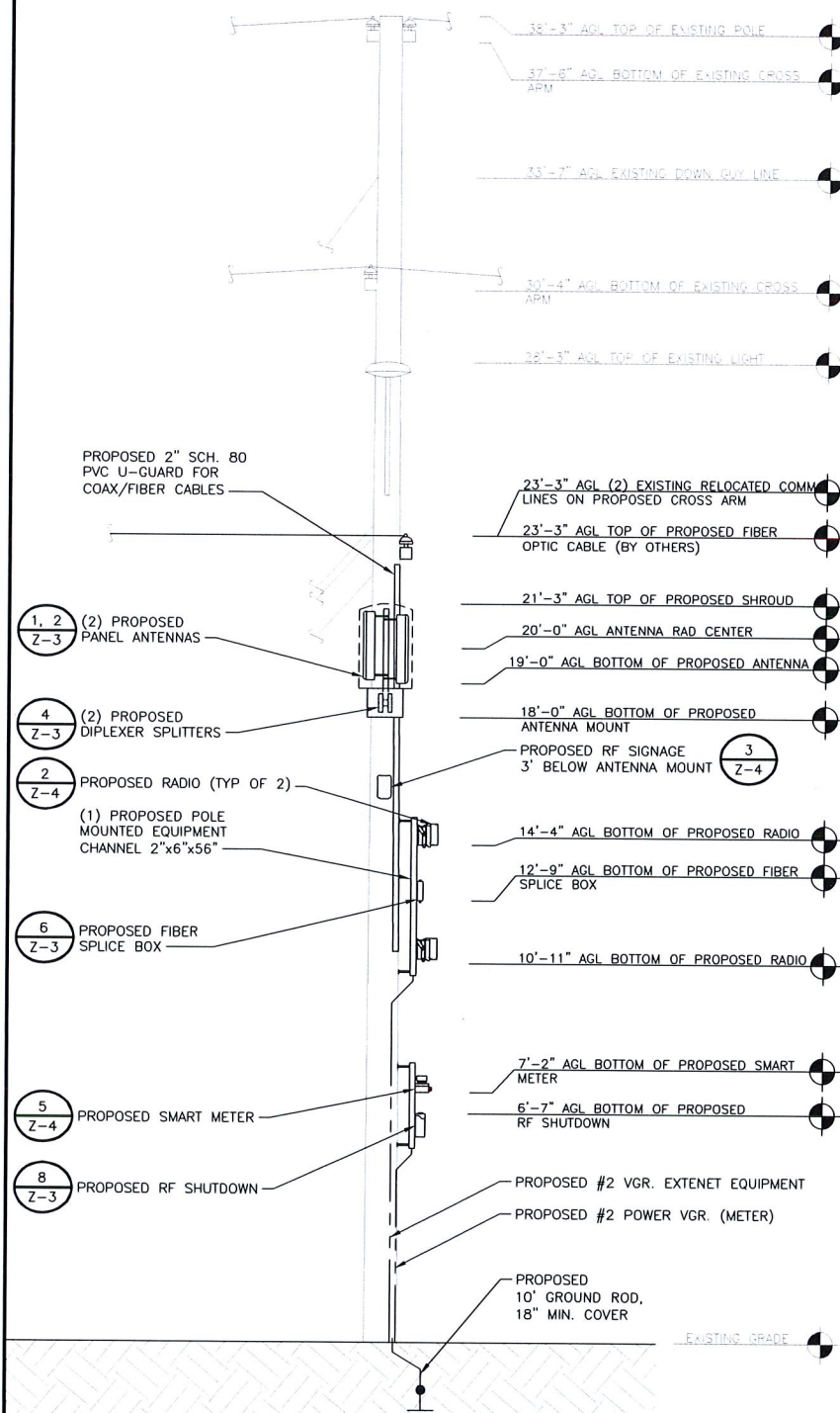

PROPOSED NORTHWEST ELEVATION

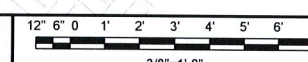

3



INTERNAL REVIEW	
CONSTRUCTION SIGNATURE	DATE
RF SIGNATURE	DATE
REAL ESTATE SIGNATURE	DATE



BLACK & VEATCH CORPORATION  
2999 OAK ROAD  
SUITE 490  
WALNUT CREEK, CA 94597

THESE DRAWINGS ARE COPYRIGHTED AND ARE THE PROPERTY OF BLACK & VEATCH; PRODUCED SOLELY FOR THE USE OF OUR CLIENT. ANY REPRODUCTION OR USE OF THE INFORMATION CONTAINED WITHIN SAID DRAWINGS IS PROHIBITED WITHOUT WRITTEN CONSENT BY BLACK & VEATCH.

PROJECT NO.	DRAWN BY	CHECKED BY
192417.6171	YJG	LW

REV	DATE	DESCRIPTION
A	06/21/17	ISSUED FOR REVIEW

IT IS A VIOLATION OF LAW FOR ANY PERSON, UNLESS THEY ARE ACTING UNDER THE DIRECTION OF A LICENSED PROFESSIONAL ENGINEER, TO ALTER THIS DOCUMENT.

EXTENET SYSTEMS (CA) LLC  
2000 CROW CANYON PLACE  
SUITE 210  
SAN RAMON, CA 94583

SITE ADDRESS  
07404  
ADJACENT TO (IN PROW)  
2701 LOGAN STREET  
OAKLAND, CA 94601

SHEET TITLE  
UTILITY POLE ELEVATIONS

SHEET NUMBER  
**Z-2**

NOTE  
ANTENNA SHROUD NOT ENTIRELY SHOWN FOR CLARITY.

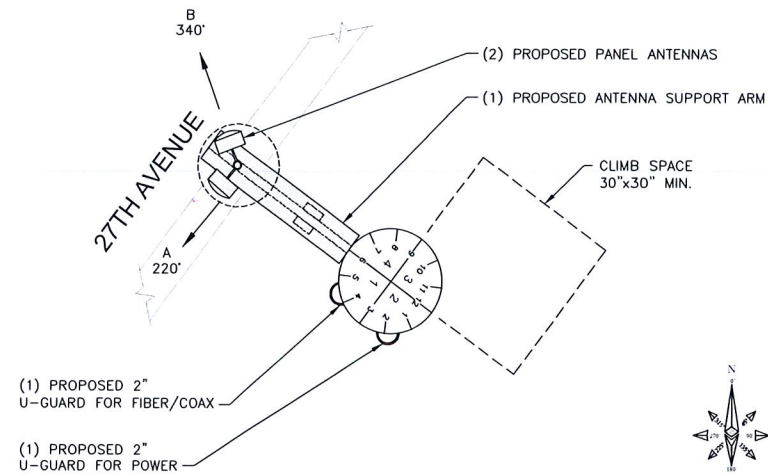

ANTENNA PLAN VIEW

NO SCALE

1

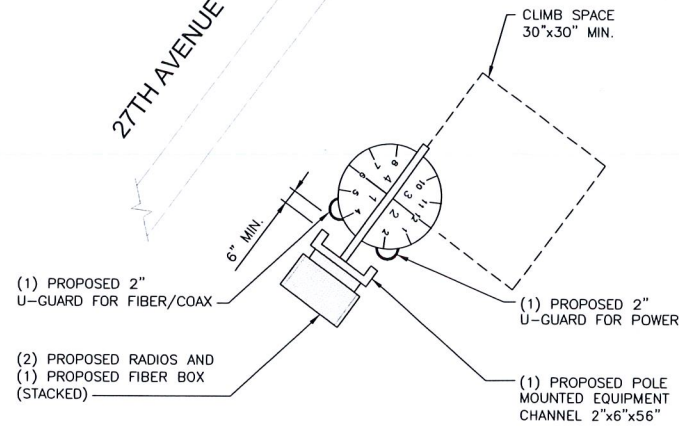

RADIO PLAN VIEW

NO SCALE

2

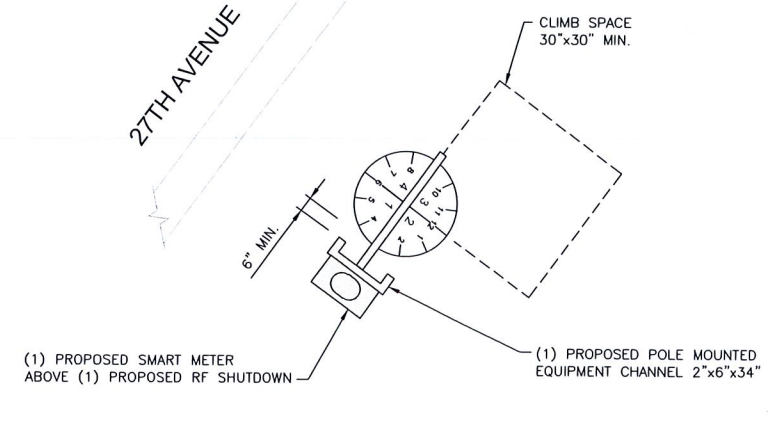

EQUIPMENT PLAN VIEW

NO SCALE

3



INTERNAL REVIEW	
CONSTRUCTION SIGNATURE	DATE
RF SIGNATURE	DATE
REAL ESTATE SIGNATURE	DATE



**BLACK & VEATCH**

BLACK & VEATCH CORPORATION  
2999 OAK ROAD  
SUITE 490  
WALNUT CREEK, CA 94597

THESE DRAWINGS ARE COPYRIGHTED AND ARE THE PROPERTY OF BLACK & VEATCH. PRODUCED SOLELY FOR THE USE OF OUR CLIENT. ANY REPRODUCTION OR USE OF THE INFORMATION CONTAINED WITHIN SAID DRAWINGS IS PROHIBITED WITHOUT WRITTEN CONSENT BY BLACK & VEATCH.

PROJECT NO.	DRAWN BY	CHECKED BY
192417.6171	YJG	LW

REV	DATE	DESCRIPTION
A	06/21/17	ISSUED FOR REVIEW

IT IS A VIOLATION OF LAW FOR ANY PERSON, UNLESS THEY ARE ACTING UNDER THE DIRECTION OF A LICENSED PROFESSIONAL ENGINEER, TO ALTER THIS DOCUMENT.

EXTENET SYSTEMS (CA) LLC  
2000 CROW CANYON PLACE  
SUITE 210  
SAN RAMON, CA 94583

SITE ADDRESS  
07404  
ADJACENT TO (IN PROW)  
2701 LOGAN STREET  
OAKLAND, CA 94601

SHEET TITLE  
RISER DETAILS

SHEET NUMBER  
**Z-2.1**

**PROPOSED ANTENNA**

RADOME COLOR: LIGHT GREY  
 RADOME MATERIAL: FIBERGLASS, UV RESISTANT  
 DEPTH: 4.1"  
 WIDTH: 6.7"  
 HEIGHT: 23.65"  
 TOTAL WEIGHT (WITHOUT BRACKETS): -  
 CONNECTOR INTERFACE: -  
 RF CONNECTOR LOCATION: BOTTOM  
 RF CONNECTOR QUANTITY: -

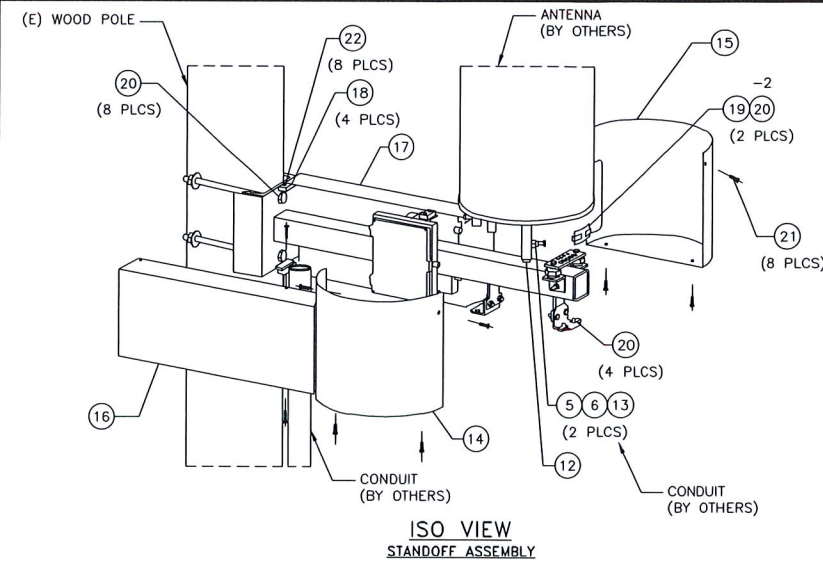
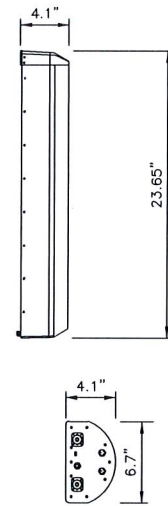

ITEM #	PART #	DESCRIPTION	QTY.	UNIT WT. (lbs)
STANDOFF ARM ASSEMBLY PARTS/HWDR				
1	WA-714	3"x3"x3/16"x3"-2" STANDOFF ARM WLDMNT	1	43
2	SS-514	2"x2"x1/4"x2" A36, ANGLE	2	0.5
3	SS-516	2"x2"x1/8"x3" A36, ANGLE	2	0.4
4	15230	3/8"x1" A307 FULLY THD'D BOLT/NUT/LW, GALV.	4	0.1
5	41010	3/8"x1" A563-A HEX NUT, GALV.	2	0.01
6	51000	3/8"x1" A563-A HEX NUT, GALV.	2	0.01
7	80326	3/8"x6" A36 THRD ROD, GALV.	1	0.19
BUS BAR ASSEMBLY PARTS / HWDR				
8	PL-718	1/4"x2"x6" COPPER, BUS BAR	1	0.8
9	43010	3/8" LOCK COPPER, BUS BAR	4	0.01
10	71017	3/8"x5/8" FULLY THD'D S.S. BOLT	4	0.04
11	90060	3/8" STANDOFF INSULATOR (559640)	2	0.1
ANTENNA / EQUIPMENT MOUNT PARTS / HDWR				
12	MAST	PANEL ANTENNA PIPE MAST	1	2.2
13	16250F	3/8"x1 1/2" A307 FULLY THD'D BOLT, GALV.	2	0.1
14	41010	3/8" LOCK WASHER, GALV.	2	0.01
15	51000	3/8" A563 HEX NUT, GALV.	2	0.02
SHROUD ASSEMBLY PARTS / HDWR				
14	WA-715L	14GA x13 1/16"x14 5/8" I.D. E.G., FORMED PLATE WLDMNT	1	8
15	WA-715R	14GA x13 1/16"x14 5/8" I.D. E.G., FORMED PLATE WLDMNT	1	8



INTERNAL REVIEW  
 CONSTRUCTION SIGNATURE DATE  
 RF SIGNATURE DATE  
 REAL ESTATE SIGNATURE DATE

BLACK & VEATCH CORPORATION  
 2999 OAK ROAD  
 SUITE 490  
 WALNUT CREEK, CA 94597

THESE DRAWINGS ARE COPYRIGHTED AND ARE THE PROPERTY OF BLACK & VEATCH; PRODUCED SOLELY FOR THE USE OF OUR CLIENT. ANY REPRODUCTION OR USE OF THE INFORMATION CONTAINED WITHIN SAID DRAWINGS IS PROHIBITED WITHOUT WRITTEN CONSENT BY BLACK & VEATCH.

PROJECT NO.	DRAWN BY	CHECKED BY
192417.6171	YJG	LW

REV	DATE	DESCRIPTION
A	06/21/17	ISSUED FOR REVIEW

IT IS A VIOLATION OF LAW FOR ANY PERSON, UNLESS THEY ARE ACTING UNDER THE DIRECTION OF A LICENSED PROFESSIONAL ENGINEER, TO ALTER THIS DOCUMENT.

EXTENET SYSTEMS (CA) LLC  
 2000 CROW CANYON PLACE  
 SUITE 210  
 SAN RAMON, CA 94583

SITE ADDRESS  
 07404  
 ADJACENT TO (IN PROW)  
 2701 LOGAN STREET  
 OAKLAND, CA 94601

SHEET TITLE  
 EQUIPMENT DETAILS

SHEET NUMBER  
**Z-3**

**ANTENNA SPECIFICATIONS**

NO SCALE

1

**PANEL ANTENNA MAST MOUNT**

NO SCALE

2

**NOT USED**

NO SCALE

3

**PROPOSED DIPLEXER**

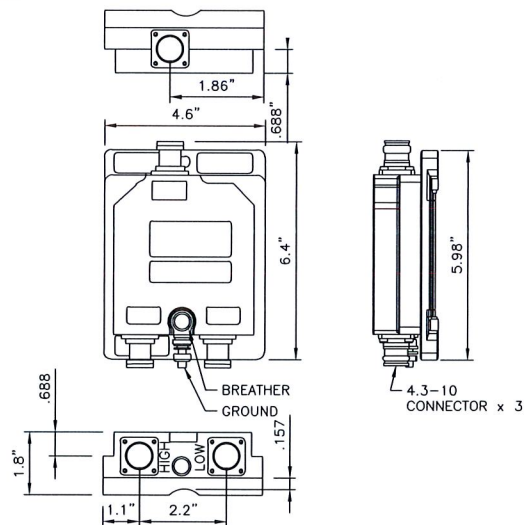

**DIPLEXER SPECIFICATIONS**

NO SCALE

4

**SIDE ARM ANTENNA MOUNT**

NO SCALE

5

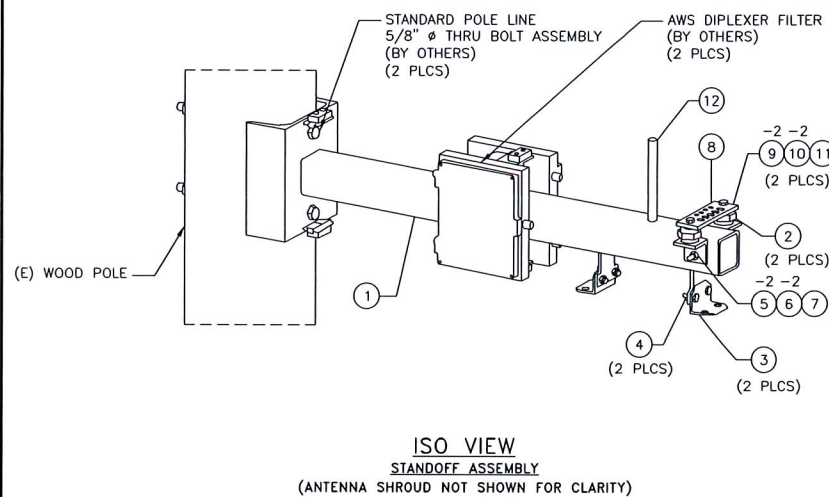

**PROPOSED RF SHUTDOWN**

LOAD CENTER DEPTH: 3.625"  
 LOAD CENTER WIDTH: 5.2"  
 LOAD CENTER HEIGHT: 8.125"  
 WEIGHT: 4.55 LB  
 LOAD CENTER TYPE: MAIN LUG  
 MAX AMPERAGE: 60  
 MOUNTING TYPE: PLUG IN  
 NUMBER OF PHASES: 1  
 NUMBER OF SPACES: 2  
 VOLTAGE (VOLTS): 120/240  
 INDOOR/OUTDOOR: OUTDOOR  
 ELECTRICAL PRODUCT TYPE: LOAD CENTER

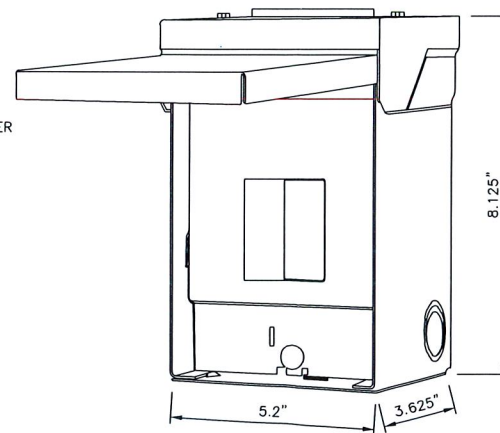

**RF SHUTDOWN SPECIFICATIONS**

NO SCALE

8

**PROPOSED SPLICE ENCLOSURE**

19	14209-4	11GA x1 1/2" x2 15/16" A36, FORMED PLATE	2	0.1
20	70217	1/4" x 1/2" STYLE SPEED NUT, BLACK PHOSPHATE	16	0.02
21	70217	1/4" x 1" SS FLGD BUTTON-HD SCKT CAP SCRW	18	0.02
22	70218	1/4" x 1" SS FLGD BUTTON-HD SCKT CAP SCRW	18	0.003

TOTAL GALV. WT. = 89lbs

**ANTENNA SHROUD PARTS TABLE**

NO SCALE

3

DEPTH: 2 1/8" (D)  
 HEIGHT: 6 3/4" (H)  
 WIDTH: 4 3/4" (W)

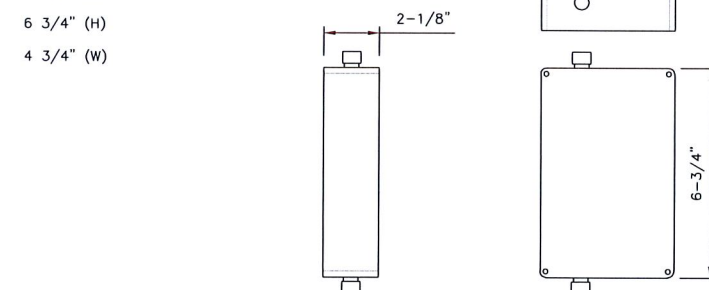

**FIBER SPLICE BOX SPECIFICATIONS**

NO SCALE

6

**ANTENNA CONFIGURATION**

NO SCALE

7

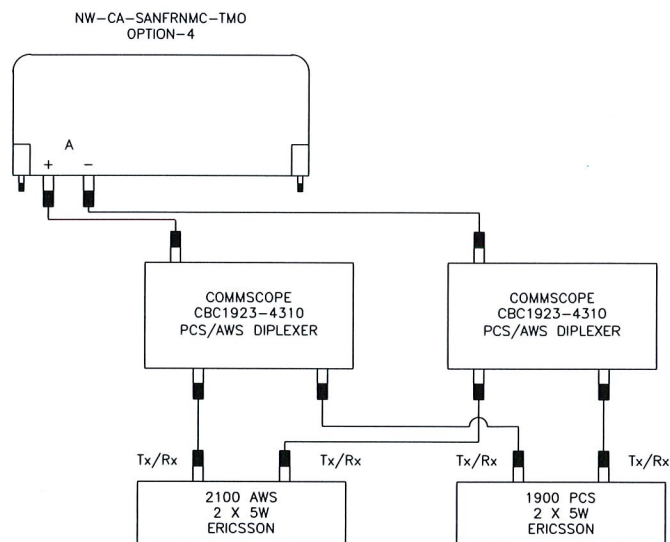

**RF SHUTDOWN SPECIFICATIONS**

NO SCALE

8

**ANTENNA MOUNT ASSEMBLY**

NO SCALE

9

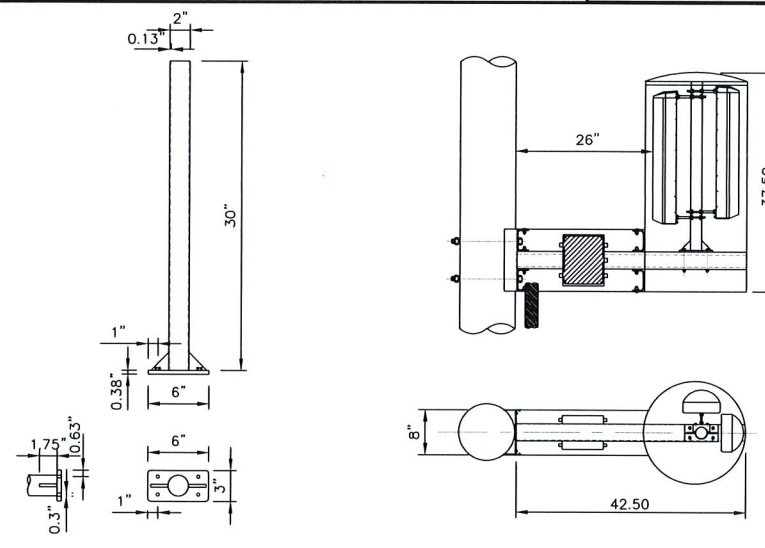

INTERNAL REVIEW	
CONSTRUCTION SIGNATURE	DATE
RF SIGNATURE	DATE
REAL ESTATE SIGNATURE	DATE



**BLACK & VEATCH**

BLACK & VEATCH CORPORATION  
2999 OAK ROAD  
SUITE 490  
WALNUT CREEK, CA 94597

THESE DRAWINGS ARE COPYRIGHTED AND ARE THE PROPERTY OF BLACK & VEATCH; PRODUCED SOLELY FOR THE USE OF OUR CLIENT. ANY REPRODUCTION OR USE OF THE INFORMATION CONTAINED WITHIN SAID DRAWINGS IS PROHIBITED WITHOUT WRITTEN CONSENT BY BLACK & VEATCH.

PROJECT NO.	DRAWN BY	CHECKED BY
192417.6171	YJG	LW

REV	DATE	DESCRIPTION
A	06/21/17	ISSUED FOR REVIEW

IT IS A VIOLATION OF LAW FOR ANY PERSON, UNLESS THEY ARE ACTING UNDER THE DIRECTION OF A LICENSED PROFESSIONAL ENGINEER, TO ALTER THIS DOCUMENT.

EXTENET SYSTEMS (CA) LLC  
2000 CROW CANYON PLACE  
SUITE 210  
SAN RAMON, CA 94583

SITE ADDRESS  
07404  
ADJACENT TO (IN PROW)  
2701 LOGAN STREET  
OAKLAND, CA 94601

SHEET TITLE  
EQUIPMENT DETAILS

SHEET NUMBER  
**Z-4**

NOT USED

NO SCALE 4

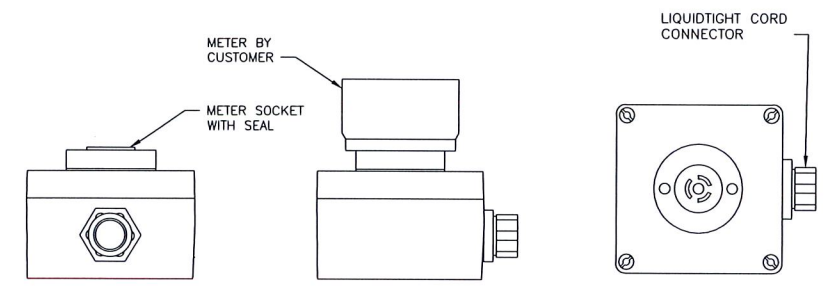

PROPOSED METER ADAPTER

NO SCALE 5

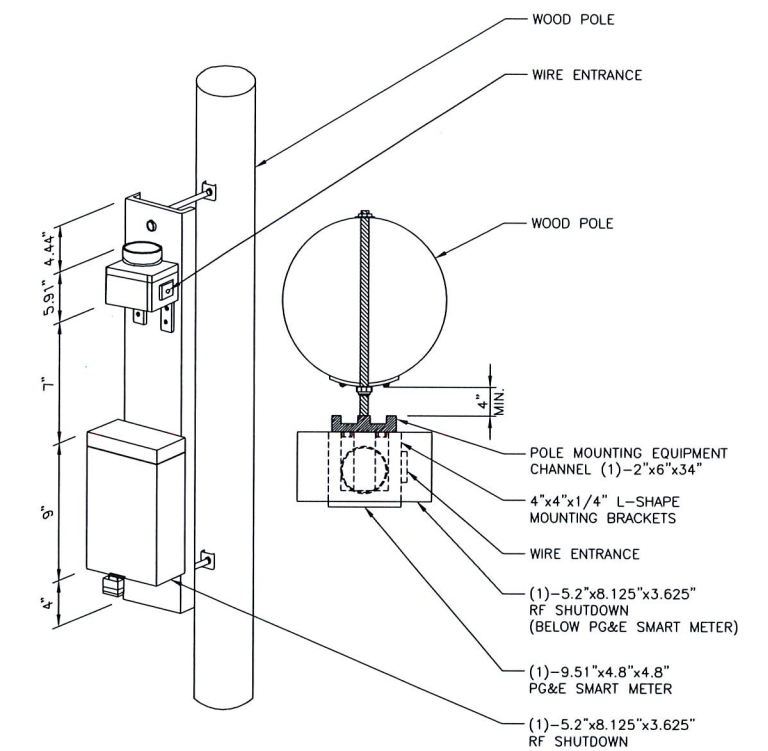

NOT USED

NO SCALE 1

PROPOSED RADIO

LENGTH: 7.8" (200MM)  
WIDTH: 7.8" (200MM)  
DEPTH: 3.93" (100MM)  
TOTAL WEIGHT: <4.5 Kg

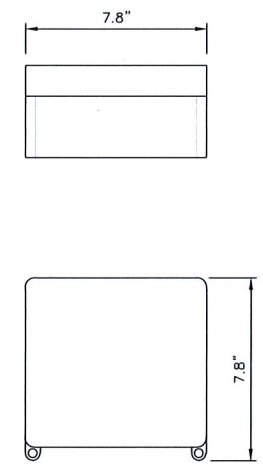
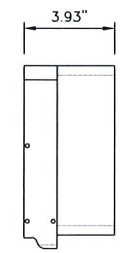

**NOTICE**

**Beyond This Point** you are entering a controlled area where RF emissions *may exceed* the FCC General Population Exposure Limits.

Follow all posted signs and site guidelines for working in a RF environment.

OWNER: TMO  
NODE: NW-CA-DTOAKLAN-07404  
NOC: 877-611-5868  
Ref: 47CFR 1.1307(b)

**CAUTION**

**Beyond This Point** you are entering a controlled area where RF emissions *may exceed* the FCC Occupational Exposure Limits.

Obey all posted signs and site guidelines for working in a RF environment.

OWNER: TMO  
NODE: NW-CA-DTOAKLAN-07404  
NOC: 877-611-5868  
Ref: 47CFR 1.1307(b)

NOTE: SPECIFIC EME PLACARD WILL BE PLACED AFTER EME REPORT

RADIO SPECIFICATIONS

NO SCALE 2

RF SIGNAGE DETAIL

NO SCALE 3

SMART METER/BREAKER BOX DETAIL

NO SCALE 6

# Attachment D

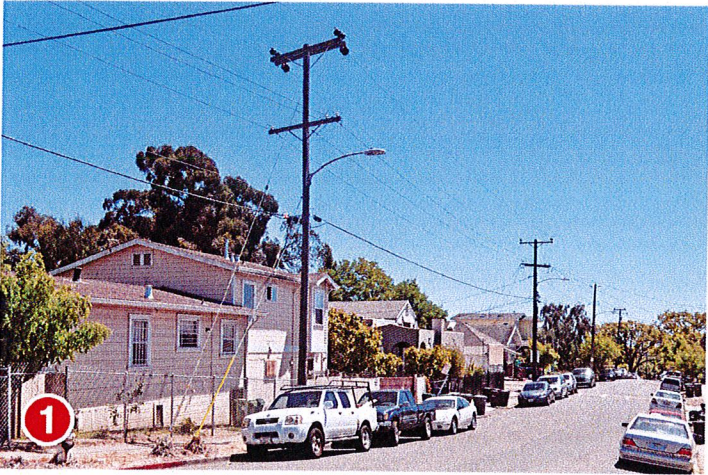



Existing



proposed antenna

Proposed





Existing



proposed antenna

Proposed



# EXTENET OAKLAND NODE 07405A ALTERNATIVE SITE ANALYSIS

Attachment E

## MAP OF ALTERNATIVE POLES EVALUATED FOR NODE 07405A



- The above maps depict ExteNet's proposed Node 07405A in relation to other poles in the area that were evaluated as possibly being viable alternative candidates.
- The following is an analysis of each of those 3 alternative locations.

# PROPAGATION MAP OF NODE 07405A

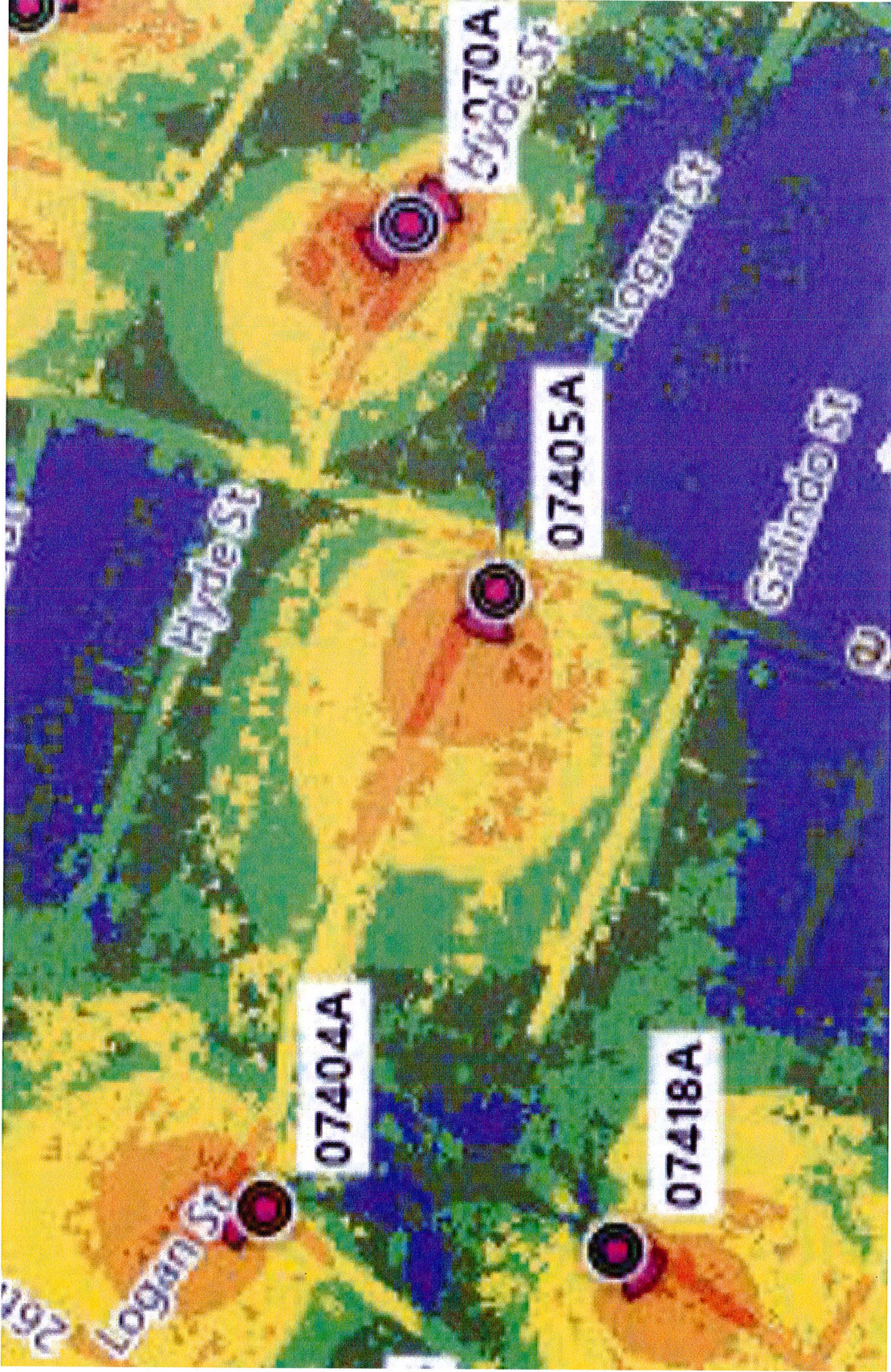

This propagation map depicts the ExteNet proposed Node 07405A in relation to surrounding proposed ExteNet small cell nodes.

## 07405A - PROPOSED LOCATION



- The location for ExteNet's proposed Node 07405A is a joint utility pole located adjacent to PROW at 2437 Fruitvale Avenue (37.787747, -122.221364).
- ExteNet's objective is to provide T-Mobile 5G wireless coverage and capacity as well as high speed wireless internet to the Oakland area.
- ExteNet evaluated this site and nearby alternatives to verify that the selected site is the least intrusive means to close T-Mobile's significant service coverage gap.

## ALTERNATIVE NODE 07405B

- Node 07405B is a joint utility pole located adjacent to PROW at 3047 Logan Street (37.787890, -122.221815).
- This pole is not a viable alternative candidate because cross lines and cross arm prevent adequate climbing space on the pole pursuant to CPUC General Order 95, thus prohibiting a wireless facility from being installed at this location.
- This pole is not a viable alternative candidate because the existing transformer on the pole would need to be relocated to an uncertain destination in order to facilitate our proposed wireless installation.
- This pole is not a viable alternative candidate because this pole is located too close to primary Node 07404E.
- This pole is not a viable alternative candidate because this pole is located too close to primary Node 07418A.
- This pole is not a viable alternative candidate because this pole is located too close to primary Node 07419B.

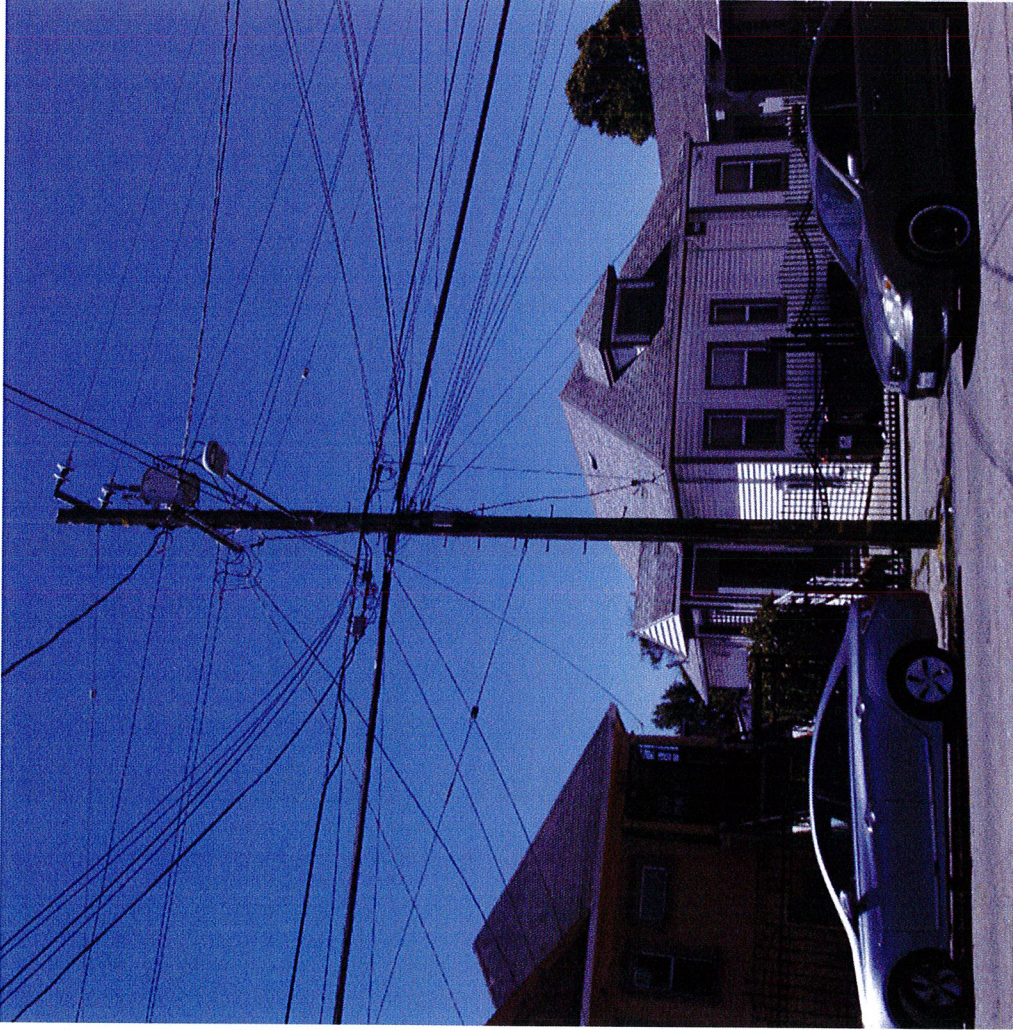

## ALTERNATIVE NODE 07405C



- Node 07405C is a joint utility pole located adjacent to PROW at 3031 Logan Street (37.788062, - 122.222325)
- This pole is not a viable alternative because the signal would be blocked by trees.
- This pole is not a viable alternative candidate because this pole is located too close to primary Node 07404E.
- This pole is not a viable alternative candidate because this pole is located too close to primary Node 07418A.
- This pole is not a viable alternative candidate because this pole is located too close to primary Node 07419B.

## ALTERNATIVE NODE 07405D



- Node 07405D is a joint utility pole located adjacent to PROW at 3015 Logan Street (37.788294, -122.222957)
- This pole is not a viable alternative candidate because cross lines and cross arms prevent adequate climbing space on the pole pursuant to CPUC General Order 95, thus prohibiting a wireless facility from being installed at this location.
- This pole is not a viable alternative candidate because placing wireless equipment on this pole would likely violate CPUC General Order-95 Regulation because all four quadrants of the pole appear occupied.
- This pole is not a viable alternative because the signal would be blocked by trees.
- This pole is not a viable alternative candidate because this pole is located too close to primary Node 07404E.
- This pole is not a viable alternative candidate because this pole is located too close to primary Node 07418A.
- This pole is not a viable alternative candidate because this pole is located too close to primary Node 07419B.



# ALTERNATIVE SITE ANALYSIS CONCLUSION

Based on ExteNet's analysis of alternative sites, the currently proposed Node 07405A is the least intrusive location from which to fill the surrounding significant wireless coverage gaps.



**SM**  
**extenet**  
**SYSTEMS**

**Thank You!**

**ExteNet Systems CA, LLC • Proposed DAS Node (Site No. 07405A)  
2437 Fruitvale Avenue • Oakland, California**

**Statement of Hammett & Edison, Inc., Consulting Engineers**

The firm of Hammett & Edison, Inc., Consulting Engineers, has been retained on behalf of ExteNet Systems CA, LLC, a wireless telecommunications facilities provider, to evaluate the addition of Node No. 07405A to be added to the ExteNet distributed antenna system (“DAS”) in Oakland, California, for compliance with appropriate guidelines limiting human exposure to radio frequency (“RF”) electromagnetic fields.

**Executive Summary**

ExteNet proposes to install a directional panel antenna on a utility pole sited in the public right-of-way near 2437 Fruitvale Avenue in Oakland. The proposed operation will comply with the FCC guidelines limiting public exposure to RF energy.

**Prevailing Exposure Standards**

The U.S. Congress requires that the Federal Communications Commission (“FCC”) evaluate its actions for possible significant impact on the environment. A summary of the FCC’s exposure limits is shown in Figure 1. These limits apply for continuous exposures and are intended to provide a prudent margin of safety for all persons, regardless of age, gender, size, or health. The most restrictive FCC limit for exposures of unlimited duration to radio frequency energy for several personal wireless services are as follows:

Wireless Service	Frequency Band	Occupational Limit	Public Limit
Microwave (Point-to-Point)	5–80 GHz	5.00 mW/cm <sup>2</sup>	1.00 mW/cm <sup>2</sup>
WiFi (and unlicensed uses)	2–6	5.00	1.00
BRS (Broadband Radio)	2,600 MHz	5.00	1.00
WCS (Wireless Communication)	2,300	5.00	1.00
AWS (Advanced Wireless)	2,100	5.00	1.00
PCS (Personal Communication)	1,950	5.00	1.00
Cellular	870	2.90	0.58
SMR (Specialized Mobile Radio)	855	2.85	0.57
700 MHz	700	2.40	0.48
[most restrictive frequency range]	30–300	1.00	0.20

Power line frequencies (60 Hz) are well below the applicable range of these standards, and there is considered to be no compounding effect from simultaneous exposure to power line and radio frequency fields.

**General Facility Requirements**

Wireless nodes typically consist of two distinct parts: the electronic transceivers (also called “radios” or “channels”) that are connected to a central “hub” (which in turn are connected to the traditional



**ExteNet Systems CA, LLC • Proposed DAS Node (Site No. 07405A)  
2437 Fruitvale Avenue • Oakland, California**

wired telephone lines), and the passive antenna(s) that send the wireless signals created by the radios out to be received by individual subscriber units. The radios are often located on the same pole as the antennas and are connected to the antennas by coaxial cables. Because of the short wavelength of the frequencies assigned by the FCC for wireless services, the antennas require line-of-sight paths for their signals to propagate well and so are installed at some height above ground. The antennas are designed to concentrate their energy toward the horizon, with very little energy wasted toward the sky or the ground. This means that it is generally not possible for exposure conditions to approach the maximum permissible exposure limits without being physically very near the antennas.

### **Computer Modeling Method**

The FCC provides direction for determining compliance in its Office of Engineering and Technology Bulletin No. 65, "Evaluating Compliance with FCC-Specified Guidelines for Human Exposure to Radio Frequency Radiation," dated August 1997. Figure 2 attached describes the calculation methodologies, reflecting the facts that a directional antenna's radiation pattern is not fully formed at locations very close by (the "near-field" effect) and that at greater distances the power level from an energy source decreases with the square of the distance from it (the "inverse square law"). The conservative nature of this method for evaluating exposure conditions has been verified by numerous field tests.

### **Site and Facility Description**

Based upon information provided by ExteNet, including drawings by Black & Veatch Corporation, dated November 30, 2017, it is proposed to install one Rosenberger Model BA-O3O3T3T3VFX65F-06\* 2-foot tall directional panel antenna, on a cross-arm to be added to a utility pole sited in the public right-of-way on Logan Street, adjacent to the residence located at 2437 Fruitvale Avenue in Oakland. The antenna would employ up to 2° downtilt, would be mounted at an effective height of about 20 feet above ground, and would be oriented toward 290°T. T-Mobile proposes to operate from this facility with a maximum effective radiated power in any direction of 212 watts, representing simultaneous operation at 2 watts for 5 GHz WiFi, 110 watts for AWS, and 100 watts for PCS service. There are reported no other wireless telecommunications base stations at this site or nearby.

### **Study Results**

For a person anywhere at ground, the maximum RF exposure level due to the proposed T-Mobile operation is calculated to be 0.0064 mW/cm<sup>2</sup>, which is 0.64% of the applicable public exposure limit. The maximum calculated level at the top-floor elevation of any nearby building is 3.4% of the public

---

\* Preliminary antenna pattern data used for the purposes of this study.



**ExteNet Systems CA, LLC • Proposed DAS Node (Site No. 07405A)  
2437 Fruitvale Avenue • Oakland, California**

exposure limit. It should be noted that these results include several “worst-case” assumptions and therefore are expected to overstate actual power density levels from the proposed operation.

**Recommended Mitigation Measures**

Due to its mounting location and height, the ExteNet antenna would not be accessible to the general public, and so no mitigation measures are necessary to comply with the FCC public exposure guidelines. To prevent occupational exposures in excess of the FCC guidelines, it is recommended that appropriate RF safety training be provided to all authorized personnel who have access to the antenna. No access within 2 feet directly in front of the antenna itself, such as might occur during certain maintenance activities, should be allowed while the node is in operation, unless other measures can be demonstrated to ensure that occupational protection requirements are met. Posting explanatory signs<sup>†</sup> on the pole at or below the antenna, such that the signs would be readily visible from any angle of approach to persons who might need to work within that distance, would be sufficient to meet FCC-adopted guidelines.

**Conclusion**

Based on the information and analysis above, it is the undersigned’s professional opinion that operation of the node proposed by ExteNet Systems CA, LLC, near 2437 Fruitvale Avenue in Oakland, California, will comply with the prevailing standards for limiting public exposure to radio frequency energy and, therefore, will not for this reason cause a significant impact on the environment. The highest calculated level in publicly accessible areas is much less than the prevailing standards allow for exposures of unlimited duration. This finding is consistent with measurements of actual exposure conditions taken at other operating nodes. Training personnel and posting signs is recommended to establish compliance with occupational exposure limitations.

---

<sup>†</sup> Signs should comply with OET-65 color, symbol, and content recommendations. Contact information should be provided (e.g., a telephone number) to arrange for access to restricted areas. The selection of language(s) is not an engineering matter, and guidance from the landlord, local zoning or health authority, or appropriate professionals may be required. Signage may also need to comply with the requirements of California Public Utilities Commission General Order No. 95.



**ExteNet Systems CA, LLC • Proposed DAS Node (Site No. 07405A)  
2437 Fruitvale Avenue • Oakland, California**

**Authorship**

The undersigned author of this statement is a qualified Professional Engineer, holding California Registration No. E-18063, which expires on June 30, 2019. This work has been carried out under his direction, and all statements are true and correct of his own knowledge except, where noted, when data has been supplied by others, which data he believes to be correct.

December 13, 2017

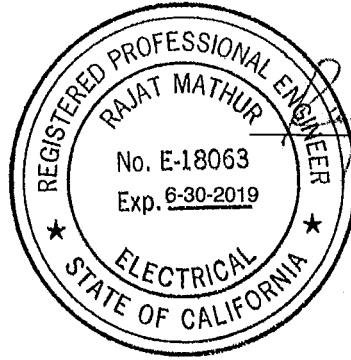

*Rajat Mathur*  
Rajat Mathur, P.E.  
707/996-5200



## FCC Radio Frequency Protection Guide

The U.S. Congress required (1996 Telecom Act) the Federal Communications Commission (“FCC”) to adopt a nationwide human exposure standard to ensure that its licensees do not, cumulatively, have a significant impact on the environment. The FCC adopted the limits from Report No. 86, “Biological Effects and Exposure Criteria for Radiofrequency Electromagnetic Fields,” published in 1986 by the Congressionally chartered National Council on Radiation Protection and Measurements (“NCRP”). Separate limits apply for occupational and public exposure conditions, with the latter limits generally five times more restrictive. The more recent standard, developed by the Institute of Electrical and Electronics Engineers and approved as American National Standard ANSI/IEEE C95.1-2006, “Safety Levels with Respect to Human Exposure to Radio Frequency Electromagnetic Fields, 3 kHz to 300 GHz,” includes similar limits. These limits apply for continuous exposures from all sources and are intended to provide a prudent margin of safety for all persons, regardless of age, gender, size, or health.

As shown in the table and chart below, separate limits apply for occupational and public exposure conditions, with the latter limits (in *italics* and/or dashed) up to five times more restrictive:

Frequency Applicable Range (MHz)	Electromagnetic Fields (f is frequency of emission in MHz)					
	Electric Field Strength (V/m)		Magnetic Field Strength (A/m)		Equivalent Far-Field Power Density (mW/cm <sup>2</sup> )	
0.3 – 1.34	614	<i>614</i>	1.63	<i>1.63</i>	100	<i>100</i>
1.34 – 3.0	614	<i>823.8/f</i>	1.63	<i>2.19/f</i>	100	<i>180/f<sup>2</sup></i>
3.0 – 30	1842/f	<i>823.8/f</i>	4.89/f	<i>2.19/f</i>	900/f <sup>2</sup>	<i>180/f<sup>2</sup></i>
30 – 300	61.4	<i>27.5</i>	0.163	<i>0.0729</i>	1.0	<i>0.2</i>
300 – 1,500	<i>3.54√f</i>	<i>1.59√f</i>	<i>√f/106</i>	<i>√f/238</i>	<i>f/300</i>	<i>f/1500</i>
1,500 – 100,000	137	<i>61.4</i>	0.364	<i>0.163</i>	5.0	<i>1.0</i>

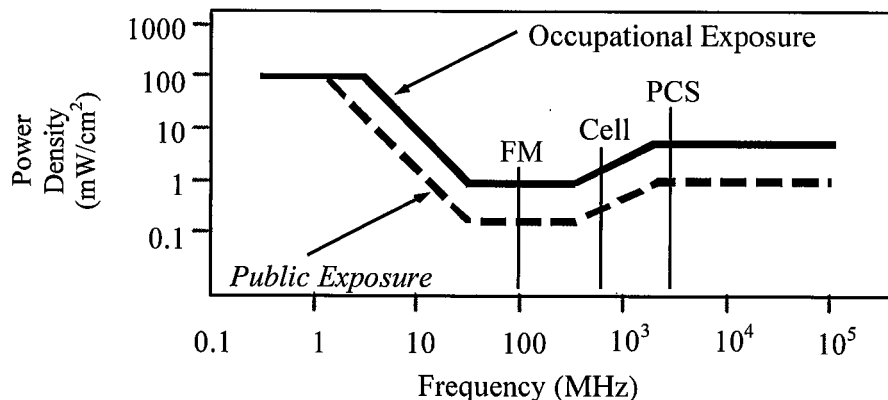

Higher levels are allowed for short periods of time, such that total exposure levels averaged over six or thirty minutes, for occupational or public settings, respectively, do not exceed the limits, and higher levels also are allowed for exposures to small areas, such that the spatially averaged levels do not exceed the limits. However, neither of these allowances is incorporated in the conservative calculation formulas in the FCC Office of Engineering and Technology Bulletin No. 65 (August 1997) for projecting field levels. Hammett & Edison has built those formulas into a proprietary program that calculates, at each location on an arbitrary rectangular grid, the total expected power density from any number of individual radio sources. The program allows for the description of buildings and uneven terrain, if required to obtain more accurate projections.



## RFR.CALC™ Calculation Methodology

### Assessment by Calculation of Compliance with FCC Exposure Guidelines

The U.S. Congress required (1996 Telecom Act) the Federal Communications Commission ("FCC") to adopt a nationwide human exposure standard to ensure that its licensees do not, cumulatively, have a significant impact on the environment. The maximum permissible exposure limits adopted by the FCC (see Figure 1) apply for continuous exposures from all sources and are intended to provide a prudent margin of safety for all persons, regardless of age, gender, size, or health. Higher levels are allowed for short periods of time, such that total exposure levels averaged over six or thirty minutes, for occupational or public settings, respectively, do not exceed the limits.

#### Near Field.

Prediction methods have been developed for the near field zone of panel (directional) and whip (omnidirectional) antennas, typical at wireless telecommunications base stations, as well as dish (aperture) antennas, typically used for microwave links. The antenna patterns are not fully formed in the near field at these antennas, and the FCC Office of Engineering and Technology Bulletin No. 65 (August 1997) gives suitable formulas for calculating power density within such zones.

For a panel or whip antenna, power density  $S = \frac{180}{\theta_{BW}} \times \frac{0.1 \times P_{net}}{\pi \times D \times h}$ , in mW/cm<sup>2</sup>,

and for an aperture antenna, maximum power density  $S_{max} = \frac{0.1 \times 16 \times \eta \times P_{net}}{\pi \times h^2}$ , in mW/cm<sup>2</sup>,

where  $\theta_{BW}$  = half-power beamwidth of the antenna, in degrees, and

$P_{net}$  = net power input to the antenna, in watts,

$D$  = distance from antenna, in meters,

$h$  = aperture height of the antenna, in meters, and

$\eta$  = aperture efficiency (unitless, typically 0.5-0.8).

The factor of 0.1 in the numerators converts to the desired units of power density.

#### Far Field.

OET-65 gives this formula for calculating power density in the far field of an individual RF source:

$$\text{power density } S = \frac{2.56 \times 1.64 \times 100 \times RFF^2 \times ERP}{4 \times \pi \times D^2}, \text{ in mW/cm}^2,$$

where ERP = total ERP (all polarizations), in kilowatts,

RFF = relative field factor at the direction to the actual point of calculation, and

$D$  = distance from the center of radiation to the point of calculation, in meters.

The factor of 2.56 accounts for the increase in power density due to ground reflection, assuming a reflection coefficient of 1.6 (1.6 x 1.6 = 2.56). The factor of 1.64 is the gain of a half-wave dipole relative to an isotropic radiator. The factor of 100 in the numerator converts to the desired units of power density. This formula has been built into a proprietary program that calculates, at each location on an arbitrary rectangular grid, the total expected power density from any number of individual radiation sources. The program also allows for the description of uneven terrain in the vicinity, to obtain more accurate projections.







November 29, 2017

City Planner  
Planning Department  
City of Oakland  
250 Frank H. Ogawa Plaza, 2<sup>nd</sup> Floor  
Oakland, CA 94612

**Re: GO 95 Required Two Feet Clearance Between Antenna and Pole**  
**Applicant: ExteneNet Systems (California) LLC**  
**Nearest Site Address: Public Right of Way near 2701 Logan Street**  
**Site ID: NW-CA-SANFRANMC-TMO Node 07404A**  
**Latitude/Longitude: lat 37.788544- long -122.224041**  
**Planning Application: PLN17307**

Dear City Planner,

This letter is in response to discussions with City of Oakland Planning Department seeking clarification on the proposed antenna placement on the utility pole.

Wireless facility attachments to utility poles must comply with CPUC General Order 95 design, safety and clearance standards. Specifically, Rule 94.4(E) states: *Antennas shall maintain a 2 ft horizontal clearance from centerline of pole when affixed between supply and communication lines or below communication lines.* This rule precludes ExteneNet from placing the antennas flush mounted to the utility pole when there is a power source attached to the pole. ExteneNet minimized the clearance as much as possible by placing the antenna shroud just over two feet from the centerline of the utility pole.

Feel free to contact me if you have any questions. Thank you.

Thank you.

Best Regards,

Ana Gomez  
ExteneNet Permitting Contractor

**Attachment G**

Decision 06-04-063 April 27, 2006

**BEFORE THE PUBLIC UTILITIES COMMISSION OF THE STATE OF CALIFORNIA**

Application of ClearLinx Network Corporation (U-6959-C) for a Modification to its Certificate of Public Convenience and Necessity in Order to Provide Competitive Local Exchange, Access and Non-Dominant Interexchange Services.

Application 05-07-025  
(Filed July 27, 2005)

**OPINION GRANTING MODIFICATION  
OF CERTIFICATE OF PUBLIC CONVENIENCE AND NECESSITY**

**I. Summary**

ClearLinx Network Corporation (U-6959-C) (Applicant) seeks a modification of its existing certificate of public convenience and necessity (CPCN) under Pub. Util. Code § 1001 to obtain authority to provide full facilities-based local exchange and interexchange telecommunications services. We grant the application, subject to the requirements and conditions stated below.

We also specify a procedure to be followed if Applicant wishes to pursue full facilities-based construction activities that involve potential exemptions from environmental review under the California Environmental Quality Act (CEQA).

**II. Background**

Applicant, a Delaware corporation, seeks authority to provide full facilities-based local exchange and interexchange services. Applicant's principal

---

<sup>1</sup> In Decision (D.) 05-07-004, the Commission previously granted Applicant a CPCN (U-6959-C) authorizing the provision of limited facilities-based interexchange services in California.

place of business is located at 1901 S. Meyers Road, Suite 190, Oakbrook Terrace, IL 60181.

In this application, Applicant requests full facilities-based authority to provide local exchange services in the service territories of Pacific Bell Telephone Company, Verizon California Inc., SureWest Telephone,<sup>2</sup> and Citizens Telephone Company and interexchange services statewide.

Applicant plans to initially offer point to point circuits carried on fiber optic facilities. These point to point circuits will carry the Radio Frequency traffic of wireless services providers (WSPs) between Applicant's newly-deployed share distributed antenna systems and the WSPs' existing facilities. Applicant states that these fiber-fed shared distributed antenna systems will extend wireless networks, will address the increasing demand from WSPs for a solution to long-standing service coverage problems, and will provide network enhancements that add capacity to accommodate high speed data applications.

Applicant proposes to provide these services through a combination of its own facilities and services leased from existing carriers and other suppliers. The fiber optic facilities will be deployed primarily in an aerial configuration, attached to utility poles and other aerial support structures. However, for some routes, Applicant may need to construct additional facilities in or near to rights-of-way.<sup>3</sup>

---

<sup>2</sup> SureWest Telephone was formerly known as Roseville Telephone Company.

<sup>3</sup> ClearLinx states in its Supplement that its plant construction will differ from other, more traditional telecommunications providers because:

- Its projects consist largely of deploying aerial facilities (fiber optic cable and pole-mounted antenna node equipment);
- Its projects will cover short distances;
- Its projects are widely separated geographically, and are not interconnected in a traditional network; and

*Footnote continued on next page*

The requirements for the expanded CPCN authority requested by Applicant here are the same as those previously met by Applicant for its existing CPCN (U-6959-C), except for the requirements of the CEQA as applied to any proposed full facilities-based construction by Applicant. Therefore, the only issue before us in this application is whether Applicant's proposed construction and process for requesting determinations of exemption from CEQA by Commission staff meets the requirements of CEQA and should be approved. Applicant remains subject to the requirements of D.05-07-004, which granted Applicant authority to provide limited facilities-based interexchange services.

### **III. Environmental (CEQA) Review**

The CEQA (Public Resources Code Sections 21000 et seq.) applies to discretionary projects to be carried out or approved by public agencies. A basic purpose of CEQA is to "inform governmental decision-makers and the public about the potential significant environmental effects of the proposed activities." (Title 14 of the California Code of Regulations, hereafter CEQA Guidelines, Section 15002.)

Since the Commission must issue a discretionary decision (i.e., grant Section 1001 certificate authority) without which the proposed activity will not proceed, the Commission must act as either a Lead or Responsible Agency under CEQA. The Lead Agency is the public agency with the greatest responsibility for supervising or approving the project as a whole (CEQA Guidelines, Section 15051(b)). The Commission is the Lead Agency for this project under

- 
- Its projects are driven by customer needs, so that ClearLinx does not know very far in advance where its next project will be located.

Applicant has also filed financial documentation, information regarding required deposits, and biographical information regarding the experience of its management, which demonstrates that Applicant otherwise meets the requirements for a full facilities-based CPCN.

CEQA. CEQA requires that the Commission consider the environmental consequences of a project that is subject to its discretionary approval.

Applicant seeks authority in this application to modify its existing CPCN to include full facilities-based competitive local exchange, access and non-dominant interexchange service. Applicant initially filed this application on July 27, 2005, and filed a supplement to the application on November 2, 2005 (Supplement) and a second supplement on February 17, 2006. Although Applicant did not file a Preliminary Environmental Assessment with the application, Applicant provided additional information in the Supplement to address compliance with Rule 17.1 of the Commission Rules of Practice and Procedure and the degree to which its planned outside construction implicates CEQA. In its application and Supplement, Applicant outlined its projected business activities and described the types of facilities it may utilize and construct, including their geographical location and extent. The application and Supplement provide adequate information to determine the environmental impacts (if any) of such activities and the degree to which such activities and facilities may be exempt from further CEQA review.

In its application and Supplement, Applicant states that its business activities associated with the installation of its Distributed Antenna System (DAS) facilities are so limited that they should potentially qualify for a number of categorical exemptions available under CEQA. In its Supplement, Applicant provides two attachments to support its case. Attachment A provides a description of the types of facilities involved in a DAS network, and Attachment B provides both a proposed procedure by which Applicant would provide notice of the claimed exemption, and a detailed list of existing CEQA categorical exemptions that would apply to the installation of DAS facilities by Applicant.

Applicant has proposed the following procedure for obtaining Commission approval of its claimed CEQA exemptions for proposed construction projects:

- Applicant will provide the Commission Energy Division with:
  - A detailed description of the proposed project, including:
    - Customer(s) to be served;
    - The precise location of the proposed construction project; and
    - Regional and local site maps.
  - A description of the environmental setting, to include at a minimum:
    - Cultural, historical, and paleontologic resources;
    - Biological resources; and
    - Current land use and zoning.
  - A construction workplan, to include:
    - Commission Preconstruction Survey Checklist—Archaeological Resources;
    - Commission Preconstruction Survey Checklist—Biological Resources;
    - A detailed schedule of construction activities, including site restoration activities;
    - A description of construction/installation techniques;
    - A list of other agencies contacted with respect to siting, land use planning, and environmental resource issues, including contact information; and
    - A list of permits required for the proposed project.
  - A statement of the CEQA exemption(s) applicable to the proposed project; and
  - Documentation and factual evidence sufficient to support a finding that the claimed exemption(s) is (are) applicable.
- The Commission Energy Division will review the Applicant's submission for the proposed project to confirm that the claimed exemption(s) from CEQA are applicable.

- Within 21 days from the date of Applicant's submittal, the Commission Energy Division will issue either:
  - A Notice to Proceed (NTP) and file a Notice of Exemption with the State Clearinghouse, Office of Planning and Research, or
  - A letter of denial stating the specific reasons why the claimed exemption(s) are not applicable to the proposed project.

The application makes clear that Applicant's facilities-based DAS projects will consist of: predominantly aerial fiber optic facilities; the installation of compact "nodes" on existing utility poles; a minor amount of ground disturbance (100 - 200 feet) associated with connecting equipment enclosures on private property with the aerial right-of-way; and aerial fiber runs of short distances, rarely exceeding 1,000 feet in length. All facilities will be located within public utility rights-of-way (with the exception of ingress and egress to and from the facilities). The projects and facilities will be widely separated geographically.

We have carefully reviewed the application and Supplement and find that:

- Applicant's proposed facilities-based project activities are very limited;
- These activities would in almost all circumstances be very likely to qualify for an exemption from CEQA; and
- The proposed process for reviewing the applicability of CEQA exemptions to Applicant's DAS facilities-based projects is not only adequate for the Commission's purposes as CEQA Lead Agency, but is also in the public interest because it enables Applicant to respond in a timely manner to WSPs' requests for service without the delay or burden of a full CEQA review when such review is unnecessary.

We therefore approve Applicant's proposed process for Commission review of claimed CEQA exemptions for construction projects undertaken pursuant to Applicant's full facilities-based authority, based on the specific facts

of this case with the following modifications related to the Commission Energy Division's review and approval or disapproval of the proposed exemptions.

- If the Commission Energy Division disapproves Applicant's claimed CEQA exemption(s), and issues a letter of denial to Applicant, Applicant shall either re-design the specific project and facilities and then reapply for a finding of exemption from CEQA, or file a formal application with the Commission seeking the requisite approval and full CEQA review, before commencing any construction activities.

Applicant shall not perform any full facilities-based construction activities without first obtaining an NTP from the Commission Energy Division or authorization by the Commission after the requisite environmental review.

However, the Commission is reviewing CEQA issues affecting telecommunications providers on a broader, policy level in Rulemaking (R.) 00-02-003. Applicant may utilize the above process for obtaining Commission review, and approval or disapproval of, proposed CEQA exemptions unless or until the Commission adopts different requirements applicable to Applicant in R.00-02-003 or a subsequent proceeding.

#### **IV. Conclusion**

We conclude that the application conforms to our rules for authority to provide full facilities-based local exchange and interexchange telecommunications services. Accordingly, we shall approve the application subject to the terms and conditions set forth herein.

#### **V. Request to File Under Seal**

Applicant requests that the financial information filed as Exhibits 2, 3, and 4 to this application be filed under seal. The financial information consists of Applicant's financial statements and financial documentation. We have granted similar requests in the past, and we grant Applicant's request here.



## **VI. Categorization and Need for Hearings**

In Resolution ALJ 176-3157 dated August 25, 2005, the Commission preliminarily categorized this proceeding as ratesetting, and preliminarily determined that hearings were not necessary. No protests have been received. There is no apparent reason why the application should not be granted. Given these developments, a public hearing is not necessary, and it is not necessary to disturb the preliminary determinations.

## **VII. Comments on the Draft Decision**

No protests were filed in this proceeding. Therefore, this is an uncontested matter in which the decision grants the relief requested. Accordingly, pursuant to Pub. Util. Code § 311(g)(2), the otherwise applicable 30-day period for public review and comment is being waived.

## **VIII. Assignment of Proceeding**

John A. Bohn is the Assigned Commissioner and Myra J. Prestidge is the assigned Administrative Law Judge in this proceeding.

## **Findings of Fact**

1. Notice of this application appeared in the Daily Calendar on August 26, 2005.
2. No protests were filed.
3. Hearings are not required.
4. Applicant seeks expansion of its existing CPCN to obtain authorization to provide full facilities-based local exchange and interexchange services by installing and operating DAS facilities.
5. The Commission is the Lead Agency for this project under CEQA.
6. Applicant filed a supplement to its application on November 2, 2005, which provided detailed information on the degree to which its planned outside construction implicates CEQA.
7. Applicant contends that its business activities associated with the installation of its DAS facilities are of such a limited nature that they should

potentially qualify for a number of categorical exemptions available under CEQA.

8. Applicant has proposed a procedure, in which Applicant would notify Commission Energy Division staff of the claimed CEQA exemptions and Commission Energy Division staff would review and act upon Applicant's claimed CEQA exemptions.

9. Applicant has provided a detailed list of existing CEQA categorical exemptions that would potentially apply to the installation of DAS facilities.

10. Applicant's proposed facilities-based project activities are of a limited nature and would in almost all circumstances be highly likely to qualify for an exemption from CEQA.

11. Applicant's proposed process for reviewing the applicability of the CEQA exemptions for DAS facilities-based projects, as modified in this decision, is adequate for the Commission's purposes as the CEQA Lead Agency and is in the public interest.

12. The Commission is reviewing CEQA issues related to telecommunications providers on a broader, policy basis in R.00-02-003.

13. As part of its second supplement to the application, Applicant submitted a draft of its initial tariffs that contained the deficiencies identified in Attachment A to this decision. Except for these deficiencies, Applicant's draft tariffs complied with the Commission's requirements.

14. Applicant has met the requirements for issuance of a CPCN authorizing the provision of full facilities-based local exchange and interexchange services.

### **Conclusions of Law**

1. Except for the requirement for additional environmental (CEQA) review, the requirements for a full facilities-based CPCN are generally the same as for a limited facilities-based CPCN.

2. Applicant's description of its future construction projects and proposed process for Commission review of claimed CEQA exemptions for these projects,

as described above, meet the requirements of CEQA, based on the specific facts of this case.

3. If the Commission subsequently adopts different requirements for review of claimed CEQA exemptions for telecommunications carriers generally in R.00-02-003 or a subsequent proceeding, Applicant should be subject to those requirements, as applicable.

4. Public convenience and necessity require Applicant's full facilities-based local exchange and interexchange services to be offered to the public subject to the terms and conditions set forth herein.

5. The application should be approved.

6. Upon approval of the application, Applicant should be subject to the applicable Commission rules, decisions, General Orders, and statutes that pertain to California public utilities.

7. Applicant should remain subject to the requirement of D.05-07-004, its licensing decision.

8. Applicant's request to file its financial information under seal should be granted, to the extent set forth below.

9. Because of the public interest in competitive local exchange services, the following order should be effective immediately.

## **O R D E R**

### **IT IS ORDERED that:**

1. A certificate of public convenience and necessity (CPCN) is granted to ClearLinx Network Corporation (Applicant) to operate as a full facilities-based provider of local exchange services in the service territories of Pacific Bell Telephone Company, Verizon California Inc., SureWest Telephone, and Citizens Telephone Company and interexchange services statewide, subject to the terms and conditions set forth below. This authorization expands Applicant's existing authority to provide limited facilities-based interexchange services in this state.

2. Applicant is authorized to construct the facilities addressed in this decision only upon receiving prior Commission approval.

3. The staff of the Commission Energy Division is authorized to review, process, and act upon Applicant's requests for a determination that its full facilities-based construction activities are exempt from the requirements of the California Environmental Quality Act (CEQA).

4. If Applicant wishes to engage in full facilities-based construction activities and believes that these activities are exempt from CEQA, Applicant shall first apply to the Commission Energy Division staff for a determination of exemption from CEQA using the following procedure:

- Applicant will provide the Commission Energy Division with:
  - A detailed description of the proposed project, including:
    - Customer(s) to be served;
    - The precise location of the proposed construction project; and
    - Regional and local site maps.
  - A description of the environmental setting, including at a minimum:
    - Cultural, historical, and paleontologic resources;
    - Biological resources; and
    - Current land use and zoning.
  - A construction workplan, including:
    - Commission Preconstruction Survey Checklist—Archaeological Resources;
    - Commission Preconstruction Survey Checklist—Biological Resources;
    - A detailed schedule of construction activities, including site restoration activities;
    - A description of construction/installation techniques;

- A list of other agencies contacted with respect to siting, land use planning, and environmental resource issues, including contact information; and
- A list of permits required for the proposed project.
- A statement of the CEQA exemption(s) claimed to apply to the proposed project; and
- Documentation supporting the finding of exemption from CEQA.
- The Commission Energy Division will then review the submittal and notify Applicant of either its approval or its denial of Applicant's claim for exemption from CEQA review within 21 days from the time that Applicant's submittal is complete.
- If the Commission Energy Division approves Applicant's claimed CEQA exemption(s), the staff will prepare a Notice to Proceed and file a Notice of Exemption with the State Clearinghouse, Office of Planning and Research.
- If the Commission Energy Division disapproves Applicant's claimed CEQA exemptions, the staff will issue to Applicant a letter which states the specific reasons that the claimed CEQA exemptions do not apply to the proposed project.
- If the Commission Energy Division disapproves Applicant's claimed CEQA exemption(s), Applicant shall either re-design the specific project and facilities and then reapply for a finding of exemption from CEQA, or file a formal application with the Commission seeking the requisite approval and full CEQA review, before commencing any full facilities-based construction activities.

5. Applicant shall not engage in any construction activity relating to a pending CEQA exemption request before receiving an NTP from Commission Energy Division staff.

6. If the Commission adopts different requirements for obtaining Commission review of proposed CEQA exemptions applicable to Applicant in Rulemaking 00-02-003 or a subsequent proceeding, Applicant shall be subject to those requirements.

7. Applicant remains subject to the requirements of Decision 05-07-004, which granted Applicant a CPCN authorizing the provision of interexchange services.

8. Applicant is authorized to file tariff schedules for the provision of competitive local exchange services. Applicant may not offer competitive local exchange services until tariffs are on file. Applicant's initial filing shall be made in accordance with General Order (GO) 96-A, excluding Sections IV, V, and VI, and shall correct the deficiency noted in Attachment A. The tariffs shall be effective not less than one day after approval by the Commission's Telecommunications Division. Applicant shall comply with its tariffs.

9. The certificate granted and the authority to render service under the rates, charges, and rules authorized herein will expire if not exercised within 12 months after the effective date of this order.

10. The corporate identification number assigned to Applicant, U-6959-C, shall be included in the caption of all original filings with this Commission, and in the titles of other pleadings filed in existing cases.

11. Applicant shall comply with all applicable rules adopted in the Local Exchange Competition proceeding (Rulemaking 95-04-043/ Investigation 95-04-044), as well as all other applicable Commission rules, decisions, GOs, and statutes that pertain to California public utilities, subject to the exemptions granted in this decision.

12. Applicant shall comply with the requirements applicable to competitive local exchange carriers included in Attachments B, C, and D to this decision.

13. Applicant's financial statements and information filed as Exhibits 2, 3, and 4 to the application shall be filed under seal and shall remain under seal for a period of two years after the date of this order. During this two-year period, the information filed as Exhibits 2, 3, and 4 to the application shall remain under seal and shall not be viewed by any person other than the Assigned Commissioner, the assigned Administrative Law Judge (ALJ), the Assistant Chief ALJ, or the Chief ALJ, except as agreed to in writing by Applicant or as ordered by a court of competent jurisdiction. If Applicant believes that it is necessary for this

A.05-07-025 ALJ/TOM/hkr

information to remain under seal for longer than two years, Applicant shall file a new motion at least 30 days before the expiration of this limited protective order.

14. Application 05-07-025 is closed.

This order is effective today.

Dated April 27, 2006, at San Francisco, California.

MICHAEL R. PEEVEY  
President  
GEOFFREY F. BROWN  
DIAN M. GRUENEICH  
JOHN A. BOHN  
RACHELLE B. CHONG  
Commissioners

**ATTACHMENT A**

List of deficiencies filed by ClearLinx Network Corporation in A.05-07-025 and to be corrected in its Tariff Compliance filing:

1. Sheet 6: Include the actual service area map in the tariff.
2. Sheet 26: Include the following in the CLC tariff: "Pursuant to Resolution T-16901, all telecommunications carriers are required to apply CPUC mandated Public Program surcharge rates (excluding (a) Universal Lifeline Telephone Service (ULTS) billings; (b) charges to other certificated carriers for services that are to be resold; (c) coin sent paid telephone calls (coin in box) and debit card calls; (d) customer-specific contracts effective before 9/15/94; (e) usage charges for coin-operated pay telephones; (f) directory advertising; and (g) one-way radio paging) and the CPUC Reimbursement Fee rate (excluding (a) directory advertising and sales; (b) terminal equipment sales; (c) inter-utility sales) to intrastate services. For a list of the Public Program surcharges and Reimbursement Fee, and the amounts, please refer to the Pacific Bell (d.b.a. SBC California) tariffs."

**(END OF ATTACHMENT A)**



**ATTACHMENT B**

**REQUIREMENTS APPLICABLE TO COMPETITIVE LOCAL EXCHANGE CARRIERS**

1. Applicant shall file, in this docket, a written acceptance of the certificate granted in this proceeding within 30 days of the effective date of this order.

2. Applicant is subject to the following fee and surcharges that must be regularly remitted per the instructions in Appendix E to Decision (D.) 00-10-028. The Combined California PUC Telephone Surcharge Transmittal Form must be submitted even if the amount due is zero.

- a. The current 1.29% surcharge applicable to all intrastate services except for those excluded by D.94-09-065, as modified by D.95-02-050, to fund the Universal Lifeline Telephone Service Trust Administrative Committee Fund (Pub. Util. Code § 879; Resolution T-16966, dated December 1, 2005, effective January 1, 2006);
- b. The current 0.27% surcharge applicable to all intrastate services except for those excluded by D.94-09-065, as modified by D.95-02-050, to fund the California Relay Service and Communications Devices Fund (Pub. Util. Code § 2881; D.98-12-073 and Resolution T-16965, dated December 1, 2005, effective January 1, 2006);
- c. The user fee provided in Pub. Util. Code §§ 431-435, which is 0.11% of gross intrastate revenue (Resolution M-4816, dated March 15, 2006, effective April 1, 2006);
- d. The current 0.21% surcharge applicable to all intrastate services except for those excluded by D.94-09-065, as modified by D.95-02-050, to fund the California High Cost Fund-A (Pub. Util. Code § 739.3; D.96-10-066, pp. 3-4, App. B, Rule 1.C; Resolution T-16963, dated December 1, 2005, effective January 1, 2006);

- e. The current 2.00% surcharge applicable to all intrastate services except for those excluded by D.94-09-065, as modified by D.95-02-050, to fund the California High Cost Fund-B (D.96-10-066, p. 191, App. B, Rule 6.F.; Resolution T-16964, dated December 1, 2005, effective January 1, 2006); and
- f. The current 0.13% surcharge applicable to all intrastate services except for those excluded by D.94-09-065, as modified by D.95-02-050, to fund the California Teleconnect Fund (D.96-10--066, p. 88, App. B, Rule 8.G; Resolution T-16888, dated December 1, 2005, effective January 1, 2006).

Note: These fees change periodically. In compliance with Resolution T-16901, December 2, 2004, Applicant should check the joint tariff for surcharges and fees filed by Pacific Bell (dba SBC California) and apply the current surcharge and fee amounts in that joint tariff on end-user bills until further revised.

3. Applicant is a competitive local exchange carrier (CLC). The effectiveness of its future tariffs is subject to the schedules set forth in Appendix C, Section 4.E of D.95-12-056:

"E. CLCs shall be subject to the following tariff and contract filing, revision and service pricing standards:

- "(1) Uniform rate reductions for existing tariff services shall become effective on five (5) working days' notice to the Commission. Customer notification is not required for rate decreases.
- "(2) Uniform major rate increases for existing tariff services shall become effective on thirty (30) days' notice to the Commission, and shall require bill inserts, or a message on the bill itself, or first class mail notice to customers at least 30 days in advance of the pending rate increase.
- "(3) Uniform minor rate increases, as defined in D.90-11-029, shall become effective on not less than five (5) working days' notice to the Commission. Customer notification is not required for such minor rate increases.

“(4) Advice letter filings for new services and for all other types of tariff revisions, except changes in text not affecting rates or relocations of text in the tariff schedules, shall become effective on forty (40) days’ notice to the Commission.

“(5) Advice letter filings revising the text or location of text material which do not result in an increase in any rate or charge shall become effective on not less than five (5) days’ notice to the Commission.

“(6) Contracts shall be subject to GO 96-A rules for NDIECs, except interconnection contracts.

“(7) CLCs shall file tariffs in accordance with PU Code Section 876.”

4. Applicant may deviate from the following provisions of GO 96-A: (a) paragraph II.C.(1)(b), which requires consecutive sheet numbering and prohibits the reuse of sheet numbers; and (b) paragraph II.C.(4), which requires that “a separate sheet or series of sheets should be used for each rule.” Tariff filings incorporating these deviations shall be subject to the approval of the Commission’s Telecommunications Division. Tariff filings shall reflect all fees and surcharges to which Applicant is subject, as reflected in 2 above.

5. Applicant shall file a service area map as part of its initial tariff.

6. Prior to initiating service, Applicant shall provide the Commission’s Consumer Affairs Branch with the name and address of its designated contact person(s) for purposes of resolving consumer complaints. This information shall be updated if the name or telephone number changes, or at least annually.

7. Applicant shall notify the Director of the Telecommunications Division in writing of the date that local exchange service is first rendered to the public, no later than five days after service first begins.

8. Applicant shall notify the Director of the Telecommunications Division in writing of the date interLATA service is first rendered to the public within

five days after service begins, and again within five days after intraLATA service begins.<sup>1</sup>

9. Applicant shall keep its books and records in accordance with the Generally Accepted Accounting Principles.

10. In the event Applicant's books and records are required for inspection by the Commission or its staff, it shall either produce such records at the Commission's offices or reimburse the Commission for the reasonable costs incurred in having Commission staff travel to its office.

11. Applicant shall file an annual report with the Director of the Telecommunications Division, in compliance with GO 104-A, on a calendar-year basis with the information contained in Attachment C to this decision.

12. Applicant shall file an affiliate transaction report with the Director of the Telecommunications Division, in compliance with D.93-02-019, on a calendar-year basis using the form contained in Attachment D.

13. Applicant shall ensure that its employees comply with the provisions of Pub. Util. Code § 2889.5 regarding solicitation of customers.

14. Within 60 days of the effective date of this order, Applicant shall comply with Pub. Util. Code § 708, Employee Identification Cards, and notify the Director of the Telecommunications Division in writing of its compliance.

15. If Applicant is 90 days or more late in filing an annual report, or in remitting the surcharges and fee listed in 2 above, the Telecommunications Division shall prepare for Commission consideration a resolution that revokes Applicant's CPCN unless it has received written permission from the Telecommunications Division to file or remit late.

---

<sup>1</sup> California is divided into ten Local Access and Transport Areas (LATAs), each containing numerous local telephone exchanges. InterLATA describes services, revenues and functions relating to telecommunications originating within one LATA and terminating in another LATA. IntraLATA describes services, revenues and functions relating to telecommunications originating within a single LATA.

16. Applicant is exempt from General Order 96-A, subsections III.G (1) and (2), and Rule 18(b) of the Commission's Rules of Practice and Procedure.
17. Applicant is exempt from Pub. Util. Code §§ 816-830.
18. Applicant is exempt from the requirements of Pub. Util. Code § 851 for the transfer or encumbrance of property whenever such transfer or encumbrance serves to secure debt.
19. If Applicant decides to discontinue service or file for bankruptcy, it shall immediately notify the Telecommunications Division's Bankruptcy Coordinator.
20. Applicant shall send a copy of this decision to concerned local permitting agencies not later than 30 days from the date of this order.

**(END OF ATTACHMENT B)**

**ATTACHMENT C**  
**ANNUAL REPORT**

An original and a machine readable, copy using Microsoft Word or compatible format shall be filed with the California Public Utilities Commission, 505 Van Ness Avenue, Room 3107, San Francisco, CA 94102-3298, no later than March 31<sup>st</sup> of the year following the calendar year for which the annual report is submitted.

Failure to file this information on time may result in a penalty as provided for in Sections 2107 and 2108 of the Public Utilities Code.

Required information:

1. Exact legal name and U # of the reporting utility.
2. Address.
3. Name, title, address, and telephone number of the person to be contacted concerning the reported information.
4. Name and title of the officer having custody of the general books of account and the address of the office where such books are kept.
5. Type of organization (e.g., corporation, partnership, sole proprietorship, etc.).  
If incorporated, specify:
  - a. Date of filing articles of incorporation with the Secretary of State.
  - b. State in which incorporated.
6. Number and date of the Commission decision granting the Certificate of Public Convenience and Necessity.
7. Date operations were begun.
8. Description of other business activities in which the utility is engaged.
9. List of all affiliated companies and their relationship to the utility. State if affiliate is a:
  - a. Regulated public utility.
  - b. Publicly held corporation.
10. Balance sheet as of December 31<sup>st</sup> of the year for which information is submitted.
11. Income statement for California operations for the calendar year for which information is submitted.

For answers to any questions concerning this report, call (415) 703-2883.

**(END OF ATTACHMENT C)**

**ATTACHMENT D**  
**CALENDAR YEAR AFFILIATE TRANSACTION REPORT**

1. Each utility shall list and provide the following information for each affiliated entity and regulated subsidiary that the utility had during the period covered by the annual Affiliate Transaction report.

- Form of organization (e.g., corporation, partnership, joint venture, strategic alliance, etc.);
- Brief description of business activities engaged in;
- Relationship to the utility (e.g., controlling corporation, subsidiary, regulated subsidiary, affiliate);
- Ownership of the utility (including type and percent ownership);
- Voting rights held by the utility and percent; and
- Corporate officers.

2. The utility shall prepare and submit a corporate organization chart showing any and all corporate relationships between the utility and its affiliated entities and regulated subsidiaries in #1 above. The chart should have the controlling corporation (if any) at the top of the chart; the utility and any subsidiaries and/or affiliates of the controlling corporation in the middle levels of the chart and all secondary subsidiaries and affiliates (e.g., a subsidiary that in turn is owned by another subsidiary and/or affiliate) in the lower levels. Any regulated subsidiary should be clearly noted.

3. For a utility that has individuals who are classified as "controlling corporations" of the competitive utility, the utility must only report under the requirements of #1 and #2 above any affiliated entity that either (a) is a public utility or (b) transacts any business with the utility filing the annual report excluding the provision of tariff services.

4. Each annual report must be signed by a corporate officer of the utility stating under penalty of perjury under the laws of the State of California

(CCP 2015.5) that the annual report is complete and accurate with no material omissions.

5. Any required material that a utility is unable to provide must be reasonably described and the reasons the data cannot be obtained, as well as the efforts expended to obtain the information, must be set forth in the utility's annual Affiliate Transaction Report and verified in accordance with Sections I-F of Decision 93-02-019.

6. Utilities that do not have affiliated entities must file, in lieu of the annual transaction report, an annual statement to the commission stating that the utility had no affiliated entities during the report period. This statement must be signed by a corporate officer of the utility, stating under penalty of perjury under the laws of the State of California (CCP 2015.5) that the annual report is complete and accurate with no material omissions.

**(END OF ATTACHMENT D)**



# NOTICE

# OAKLAND



**CITY OF OAKLAND**  
**BUREAU OF PLANNING**  
 250 Frank H. Ogawa Plaza, Suite 2114, Oakland, CA 94612-2031  
 Phone: 510-238-3911 Fax: 510-238-4730  
**PLANNING COMMISSION PUBLIC NOTICE**

<b>Location:</b>	Utility pole in sidewalk adjacent to: 2701 Logan Street (along 27 <sup>th</sup> Ave)
<b>Assessor's Parcel Number(s):</b>	026-0763-001-00
<b>Proposal:</b>	To establish a "small cell site" telecommunications facility in order to enhance existing services by attaching two panel antennas on top of a 38'-3" wooden utility pole located in the public right-of-way (sidewalk). The antennas would be up to 21'-3" in height and equipment mounted at a height of 6'-7" to 14'-4" above ground-level.
<b>Applicant / Phone Number:</b>	Ana Gomez/Black & Veatch & Extenet (for: T-Mobile) (913) 458-9148
<b>Owner:</b>	Extenet Systems California, LLC
<b>Case File Number:</b>	PLN17307
<b>Planning Permits Required:</b>	Regular Design Review with additional findings for Macro Telecommunications Facility
<b>General Plan:</b>	Mixed Housing Type Residential
<b>Zoning:</b>	RM-3 Mixed Housing Type Residential - 3 Zone
<b>Environmental Determination:</b>	Exempt, Section 15301 of the State CEQA Guidelines: Existing Facilities; Exempt, Section 15302: Replacement or Reconstruction; Exempt, Section 15303: New Construction of Small Structures; Section 15183: Projects Consistent with a Community Plan, General Plan or Zoning
<b>Historic Status:</b>	Non historic property
<b>City Council District:</b>	5
<b>Date Filed:</b>	August 16, 2017
<b>Action to be Taken:</b>	Decision based on staff report
<b>Finality of Decision:</b>	Appealable to City Council
<b>For Further Information:</b>	Contact case planner Marilu Garcia at (510) 238-5217 or by email at <a href="mailto:mgarcia2@oaklandnet.com">mgarcia2@oaklandnet.com</a> .

Your comments and questions, if any, should be directed to the Bureau of Planning, 250 Frank H. Ogawa Plaza, 2nd Floor, Oakland, California 94612-2031 at or prior to the public hearing to be held on **December 29, 2017**, at Oakland City Hall, Council Chambers, 1 Frank H. Ogawa Plaza, Oakland, California 94612. The public hearing will start at 6:00 p.m.

If you challenge the Planning Commission decision on appeal and/or in court, you will be limited to issues raised at the public hearing or in correspondence delivered to the Bureau of Planning, at, or prior to, the public hearing on this case. If you wish to be notified of the decision of any of these cases, please provide the case planner with a regular mail or email address.

Please note that the description of the application found above is preliminary in nature and that the project and/or such description may change prior to a decision being made. Except where noted, once a decision is reached by the Planning Commission on these cases, they are appealable to the City Council. **Such appeals must be filed within ten (10) calendar days of the date of decision by the Planning Commission and by 4:00p.m.** An appeal shall be on a form provided by the Bureau of Planning, and submitted to the same at 250 Frank H. Ogawa Plaza, Suite 2114, to the attention of the Case Planner. The appeal shall state specifically wherein it is claimed there was error or abuse of discretion by the City of Oakland or wherein the decision is not supported by substantial evidence and must include payment in accordance with the City of Oakland Master Fee Schedule. Failure to file a timely appeal will preclude you from challenging the City's decision in court. The appeal itself must raise every issue that is contested along with all the arguments and evidence previously entered into the record prior to or at the public hearing mentioned above. Failure to do so will preclude you from raising such issues during the appeal hearing and/or in court.

POSTING DATE: **December 1, 2017**

IT IS UNLAWFUL TO ALTER OR REMOVE THIS NOTICE WHEN POSTED ON SITE

PLEASE CALL ZONING AT (510) 238-3911. FOR BLIGHT NOTICES, PLEASE CALL (510) 238-6402

