

# MANDELA STATION

@ West Oakland BART

## FINAL DEVELOPMENT PLAN HORIZONTAL IMPROVEMENTS

July 24, 2020

Amended September 16, 2020



HENSEL PHELPS



# WEST OAKLAND BART HORIZONTAL IMPROVEMENT

## GENERAL

G100 TITLE SHEET, DRAWING INDEX

## CONTEXT INFO

A-00.01 - RENDERINGS  
 A-00.17  
 A00.18 ZONING INFO  
 A00.19 ZONING SUMMARY  
 A00.20 PHASING PLAN

## PHASING

A11.01 PHASE 1A, CURB RELOCATION  
 A11.02 PHASE 1A, REORGANIZED ROUTES  
 A11.03 PHASE 1B, T3 SITE PREPARATION  
 A11.04 PHASE 1B, REORGANIZED ROUTES  
 A11.05 PHASE 2A, T3 SITE EXCAVATION  
 A11.06 PHASE 2A, REORGANIZED ROUTES  
 A11.07 PHASE 2B, T3 BUILDING CONSTRUCTION  
 A11.08 PHASE 2B, REORGANIZED ROUTES  
 A11.09 PHASE 2C, FINISH T3 PAVING OF SIDE WALK  
 A11.10 PHASE 2C, REORGANIZED ROUTES  
 A11.11 PHASE 3A, FINISH T2 PAVING OF SIDE WALK  
 A11.12 PHASE 3A, REORGANIZED ROUTES  
 A11.13 PHASE 3B, T2 PLAZA CONSTRUCTION  
 A11.14 PHASE 3B, REORGANIZED ROUTES  
 A11.15 PHASE 4A, T1 SITE PREPARATION  
 A11.16 PHASE 4A, REORGANIZED ROUTES  
 A11.17 PHASE 4B, T1 BUILDING AND BIKE STATION CONSTRUCTION  
 A11.18 PHASE 4B, REORGANIZED ROUTES  
 A11.19 PHASE 4C, FINISH T1 PAVING OF SIDE WALK  
 A11.20 PHASE 4C, REORGANIZED ROUTES  
 A11.21 PHASE 5A, T4 SITE PREPARATION  
 A11.22 PHASE 5A, REORGANIZED ROUTES  
 A11.23 PHASE 5B, T4 SITE EXCAVATION  
 A11.24 PHASE 5B, REORGANIZED ROUTES  
 A11.25 PHASE 5C, T4 BUILDING CONSTRUCTION  
 A11.26 PHASE 5C, REORGANIZED ROUTES  
 A11.27 PHASE 5D, FINISH T4 PAVING OF SIDE WALK  
 A11.28 PHASE 5D, REORGANIZED ROUTES  
 A11.29 PHASE 6, UNDER TRACK RETAIL CONSTRUCTION  
 A11.30 PHASE 6, REORGANIZED ROUTES  
 A11.31 PHASE 7, EVERY CONSTRUCTION PHASE DONE

## CIVIL PLANS

C1.00 EXISTING CONDITIONS PLAN  
 180384 1-5 TOPOGRAPHIC AND BOUNDARY SURVEY  
 C-1.01A - TENTATIVE PARCEL MAP  
 C-1.01C  
 C1.02 LOT MERGER PLAN  
 C2.00 PROPOSED GRADING PLAN  
 C3.00 STORMWATER MANAGEMENT PLAN  
 C3.01 STORMWATER MANAGEMENT DETAILS  
 C3.02 STORMWATER MANAGEMENT DETAILS  
 C4.00 EROSION CONTROL PLAN  
 C4.01 EROSION CONTROL PLAN DETAILS  
 C5.00 PROPOSED SITE IMPROVEMENT PLAN  
 C5.01 CYCLE TRACK CASE STUDY  
 C5.02 CONSTRUCTION DETAILS  
 C5.03 CONSTRUCTION DETAILS  
 C5.04 CONSTRUCTION DETAILS  
 C5.05 CONSTRUCTION DETAILS  
 C5.06 CONSTRUCTION DETAILS  
 C6.00 PROPOSED UTILITY PLAN

## LANDSCAPE PLANS

L1.00 TREE REMOVAL PLAN  
 L1.01 LAYOUT & MATERIALS PLAN  
 L1.01.02 PUBLIC ACCESS PLAN  
 L1.02 LANDSCAPE WALL HEIGHT PLAN  
 L1.03 LANDSCAPE SECTIONS  
 L1.04 LANDSCAPE SECTIONS  
 L1.05 STREET SECTIONS  
 L1.06 PRELIMINARY LIGHTING PLAN  
 L1.07 PLANTING ZONES  
 L1.08 LANDSCAPE PLANTS  
 L1.09 LANDSCAPE MATERIALS  
 L1.10 LIGHTING IMAGES  
 L1.11 LIGHT LEVEL GOALS  
 L01.12 LANDSCAPE VIEWS

## ARCHITECTURAL PLANS, ELEVATIONS, AND DETAILS

A-9.00 SITE PLAN  
 A-9.01 PUBLIC SPACE IMPROVEMENT: PUBLIC SPACE DESIGN  
 A-9.02 PUBLIC SPACE IMPROVEMENT: MANDELA PLAZA  
 A-9.03 PUBLIC SPACE IMPROVEMENT: MANDELA PLAZA  
 A-9.04 CHILDREN'S INTERACTIVE ART  
 A-9.05 - EVENT SPACE PROGRAM  
 A-9.06 - PUBLIC SPACE IMPROVEMENT: UNDER TRACK SPACE  
 A-9.08 -  
 A-9.09 - MANDELA PLAZA  
 A9.11  
 A9.13 PUBLIC SPACE IMPROVEMENT: ART ALLEY  
 A-9.14  
 A-9.15 - PUBLIC SPACE IMPROVEMENT: CENTER SQUARE  
 A-9.19  
 A-10.01 ILLUSTRATED SITE PLAN  
 A-10.02 SITE PLAN  
 A-10.03 - PUBLIC SPACE IMPROVEMENT: CROSSWALKS & INTERSECTIONS  
 A-10.03.07  
 A-10.04.01 PUBLIC SPACE IMPROVEMENT: SIDEWALKS  
 A-10.05 PUBLIC SPACE IMPROVEMENT: BIKES  
 A-10.06 PUBLIC SPACE IMPROVEMENT: PASSENGER LOADING  
 A-10.07 PUBLIC SPACE IMPROVEMENT: BUS STOPS  
 A-10.08 EMERGENCY VEHICLE ACCESS  
 A-60.01 EVA GATE DETAIL



**MANDELA STATION  
 @WEST OAKLAND  
 BART**  
 1451 7th St, Oakland,  
 CA 94607

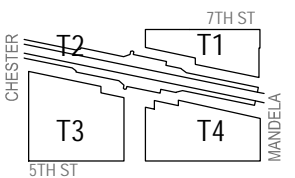

**JRDV URBAN  
 INTERNATIONAL**  
 JRDV Architects, Inc  
 The Cathedral Building  
 Broadway and Telegraph  
 PO Box 70126  
 Oakland, CA 94612 USA  
 510 295 4392 T  
 www.jrdv.com

**BKF 100+  
 YEARS**  
 ENGINEERS, SURVEYORS, PLANNERS  
**stök**  
**PGAdesign**  
 LANDSCAPE ARCHITECTS

PROJ. # 168-153 WO BART  
 DATE: July 24, 2020

**DRAWING  
 INDEX**

SHEET:  
**G-100**



**MANDELA STATION  
@WEST OAKLAND  
BART**  
1451 7th St, Oakland,  
CA 94607

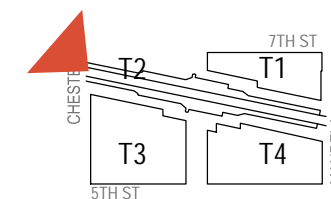

JRDV Architects, Inc  
The Cathedral Building  
Broadway and Telegraph  
PO Box 70126  
Oakland, CA 94612 USA  
510 295 4392 T  
www.jrdv.com



PROJ. # 168-153 WO BART  
DATE: July 24, 2020

**RENDERING  
7TH STREET  
LOOKING EAST**

SHEET:

**A-00.01**

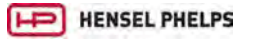

**MANDELA STATION  
@WEST OAKLAND  
BART**  
1451 7th St, Oakland,  
CA 94607

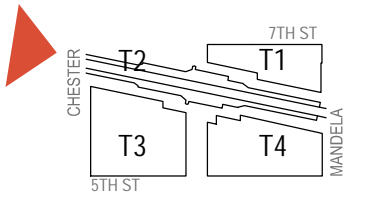

JRDV Architects, Inc  
The Cathedral Building  
Broadway and Telegraph  
PO Box 70126  
Oakland, CA 94612 USA  
510 295 4392 T  
www.jrdv.com



PROJ. # 168-153 WO BART

DATE: July 24, 2020

**7TH & CHESTER  
CORNER  
VIEW**

SHEET:

**A-00.02**



suda  
Strategic Urban Development Alliance, LLC

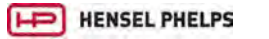

**MANDELA STATION  
@WEST OAKLAND  
BART**  
1451 7th St, Oakland,  
CA 94607

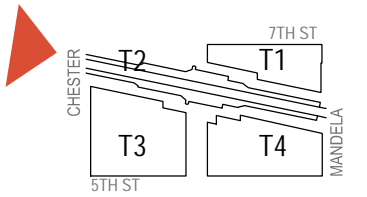

JRDV Architects, Inc  
The Cathedral Building  
Broadway and Telegraph  
PO Box 70126  
Oakland, CA 94612 USA  
510 295 4392 T  
www.jrdv.com



PROJ. # 168-153 WO BART

DATE: July 24, 2020

**7TH & CHESTER  
CORNER  
VIEW**

SHEET:  
**A-00.02**



**MANDELA STATION**  
**@WEST OAKLAND**  
**BART**  
 1451 7th St, Oakland,  
 CA 94607

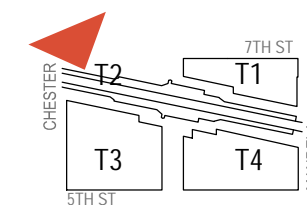

JRDV Architects, Inc  
 The Cathedral Building  
 Broadway and Telegraph  
 PO Box 70126  
 Oakland, CA 94612 USA  
 510 295 4392 T  
 www.jrdv.com



PROJ. # 168-153 WO BART  
 DATE: July 24, 2020

**AERIAL VIEW**  
**LOOKING SOUTH**

SHEET:  
**A-00.03**



suda  
Strategic Urban Development Alliance, LLC

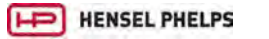

**MANDELA STATION  
@WEST OAKLAND  
BART**  
1451 7th St, Oakland,  
CA 94607

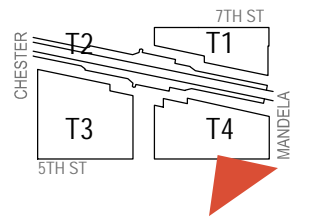

JRDV Architects, Inc  
The Cathedral Building  
Broadway and Telegraph  
PO Box 70126  
Oakland, CA 94612 USA  
510 295 4392 T  
www.jrdv.com



PROJ. # 168-153 WO BART

DATE: July 24, 2020

**5TH & MANDELA  
CORNER  
VIEW**

SHEET:

**A-00.04**



**MANDELA STATION  
@WEST OAKLAND  
BART**

1451 7th St, Oakland,  
CA 94607

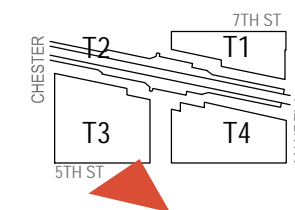

JRDV Architects, Inc  
The Cathedral Building  
Broadway and Telegraph  
PO Box 70126  
Oakland, CA 94612 USA  
510 295 4392 T  
www.jrdv.com



PROJ. # 168-153 WO BART

DATE: July 24, 2020

**AERIAL VIEW  
LOOKING NORTH**

SHEET:

**A-00.05**





**MANDELA STATION**  
**@WEST OAKLAND**  
**BART**  
 1451 7th St, Oakland,  
 CA 94607

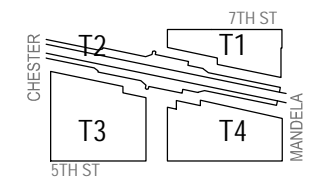

JRDV Architects, Inc  
 The Cathedral Building  
 Broadway and Telegraph  
 PO Box 70126  
 Oakland, CA 94612 USA  
 510 295 4392 T  
 www.jrdv.com



PROJ. # 168-153 WO BART  
 DATE: July 24, 2020

**MANDELA PLAZA**  
**STREET VIEW**

SHEET:  
**A-00.06**



**MANDELA STATION**  
**@WEST OAKLAND**  
**BART**  
 1451 7th St, Oakland,  
 CA 94607

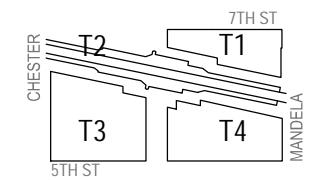

JRDV Architects, Inc  
 The Cathedral Building  
 Broadway and Telegraph  
 PO Box 70126  
 Oakland, CA 94612 USA  
 510 295 4392 T  
 www.jrdv.com



PROJ. # 168-153 WO BART  
 DATE: July 24, 2020

**MANDELA PLAZA**  
**STREET VIEW**

SHEET:  
**A-00.07**



**MANDELA STATION**  
**@WEST OAKLAND**  
**BART**  
 1451 7th St, Oakland,  
 CA 94607

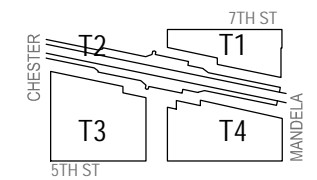

JRDV Architects, Inc  
 The Cathedral Building  
 Broadway and Telegraph  
 PO Box 70126  
 Oakland, CA 94612 USA  
 510 295 4392 T  
 www.jrdv.com



PROJ. # 168-153 WO BART  
 DATE: July 24, 2020

**MANDELA PLAZA**  
**STREET VIEW**

SHEET:  
**A-00.08**



**MANDELA STATION  
@WEST OAKLAND  
BART**  
1451 7th St, Oakland,  
CA 94607

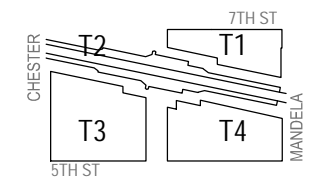

JRDV Architects, Inc  
The Cathedral Building  
Broadway and Telegraph  
PO Box 70126  
Oakland, CA 94612 USA  
510 295 4392 T  
www.jrdv.com



PROJ. # 168-153 WO BART  
DATE: July 24, 2020

**7TH & MANDELA**

SHEET:  
**A-00.09**



**MANDELA STATION  
@WEST OAKLAND  
BART**  
1451 7th St, Oakland,  
CA 94607

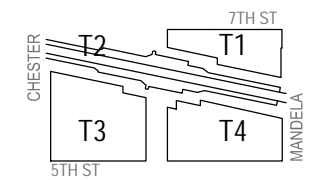

JRDV Architects, Inc  
The Cathedral Building  
Broadway and Telegraph  
PO Box 70126  
Oakland, CA 94612 USA  
510 295 4392 T  
www.jrdv.com



PROJ. # 168-153 WO BART

DATE: July 24, 2020

**ART ALLEY**

SHEET:

**A-00.10**



**MANDELA STATION  
@WEST OAKLAND  
BART**  
1451 7th St, Oakland,  
CA 94607

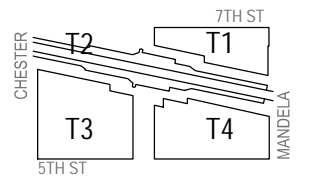

JRDV Architects, Inc  
The Cathedral Building  
Broadway and Telegraph  
PO Box 70126  
Oakland, CA 94612 USA  
510 295 4392 T  
www.jrdv.com



PROJ. # 168-153 WO BART  
DATE: July 24, 2020

## CENTER SQUARE

SHEET:  
A-00.11



MANDELA STATION  
 @WEST OAKLAND  
 BART  
 1451 7th St, Oakland,  
 CA 94607

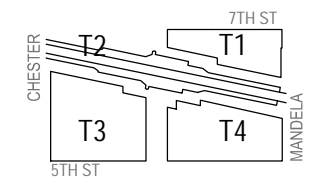

JRDV Architects, Inc  
 The Cathedral Building  
 Broadway and Telegraph  
 PO Box 70126  
 Oakland, CA 94612 USA  
 510 295 4392 T  
 www.jrdv.com



PROJ. # 168-153 WO BART  
 DATE: July 24, 2020

ART ALLEY

SHEET:  
 A-00.12



**MANDELA STATION  
@WEST OAKLAND  
BART**  
1451 7th St, Oakland,  
CA 94607

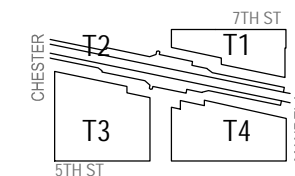

JRDV Architects, Inc  
The Cathedral Building  
Broadway and Telegraph  
PO Box 70126  
Oakland, CA 94612 USA  
510 295 4392 T  
www.jrdv.com



PROJ. # 168-153 WO BART  
DATE: July 24, 2020

## CENTER SQUARE

SHEET:  
A-00.13





**MANDELA STATION**  
**@WEST OAKLAND**  
**BART**  
 1451 7th St, Oakland,  
 CA 94607

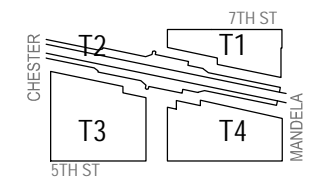

JRDV Architects, Inc  
 The Cathedral Building  
 Broadway and Telegraph  
 PO Box 70126  
 Oakland, CA 94612 USA  
 510 295 4392 T  
 www.jrdv.com



PROJ. # 168-153 WO BART  
 DATE: July 24, 2020

**CENTER SQUARE**

SHEET:  
 A-00.14



**MANDELA STATION**  
**@WEST OAKLAND**  
**BART**  
 1451 7th St, Oakland,  
 CA 94607

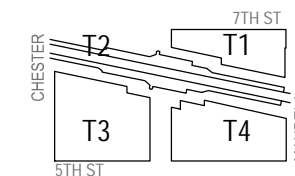

JRDV Architects, Inc  
 The Cathedral Building  
 Broadway and Telegraph  
 PO Box 70126  
 Oakland, CA 94612 USA  
 510 295 4392 T  
 www.jrdv.com



PROJ. # 168-153 WO BART  
 DATE: July 24, 2020

**5TH ST SIDEWALK  
 VIEW**

SHEET:  
**A-00.15**

5TH & MANDELA



5TH & CHESTER



7TH STREET PLAZA



MANDELA STATION  
@WEST OAKLAND

BART

1451 7th St, Oakland,  
CA 94607

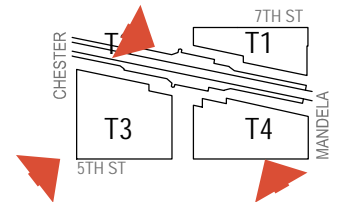

JRDV Architects, Inc  
The Cathedral Building  
Broadway and Telegraph  
PO Box 70126  
Oakland, CA 94612 USA  
510 295 4392 T  
www.jrdv.com



PROJ. # 168-153 WO BART

DATE: July 24, 2020

STREET  
VIEWS

SHEET:

A-00.16

5TH & MANDELA



5TH & CHESTER



7TH STREET PLAZA

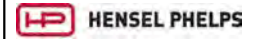

MANDELA STATION  
@WEST OAKLAND

BART

1451 7th St, Oakland,  
CA 94607

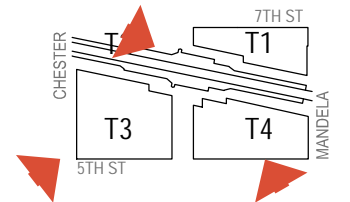

JRDV Architects, Inc  
The Cathedral Building  
Broadway and Telegraph  
PO Box 70126  
Oakland, CA 94612 USA  
510 295 4392 T  
www.jrdv.com



PROJ. # 168-153 WO BART

DATE: July 24, 2020

STREET  
VIEWS

SHEET:

A-00.16



ART ALLEY



CENTER SQUARE



MANDELA STATION  
 @WEST OAKLAND  
 BART  
 1451 7th St, Oakland,  
 CA 94607

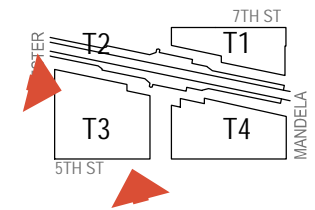

JRDV Architects, Inc  
 The Cathedral Building  
 Broadway and Telegraph  
 PO Box 70126  
 Oakland, CA 94612 USA  
 510 295 4392 T  
 www.jrdv.com



PROJ. # 168-153 WO BART  
 DATE: July 24, 2020

STREET  
 VIEWS

SHEET:  
 A-00.17



ART ALLEY



CENTER SQUARE



MANDELA STATION  
 @WEST OAKLAND  
 BART  
 1451 7th St, Oakland,  
 CA 94607

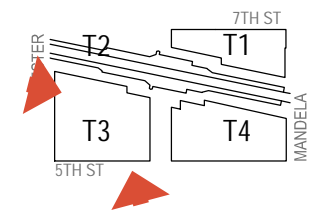

JRDV Architects, Inc  
 The Cathedral Building  
 Broadway and Telegraph  
 PO Box 70126  
 Oakland, CA 94612 USA  
 510 295 4392 T  
 www.jrdv.com



PROJ. # 168-153 WO BART  
 DATE: July 24, 2020

STREET  
 VIEWS

SHEET:  
 A-00.17

**Proposed Program**

USES	T1	T2	T3	T4	Program Total
OFFICE				300,000 sf	300,000 sf
RETAIL	14,350 sf	Flexible Kiosk Program	15,944 sf	23,184 sf	53,478 sf
OTHER NON-RESIDENTIAL			2,057 sf	8,540 sf	10,597 sf
RESIDENTIAL	522 units		240 units*		762 units (20% min. affordable)
PARKING	125		50	210	385 spaces

\*79 units at 30% AMI, 11 units at 50% AMI, 148 units at 60% AMI, 2 units at 120% AMI

Note: Program is based on the previously approved Conditions of Approval, As approved by the Planning Commission February 6, 2019.

**Open Space Calculation**

<b>Residential Open Space Req</b>		
240 Units	200	48,000 SF
522 Units	200	104,400 SF
<b>Required Open Space</b>		<b>152,400 SF</b>
<b>Open Space Provided</b>		
T1 Open Space		17,648 SF
T3 Open Space		24,815 SF
		<b>42,463* SF</b>
<b>Approximate Public Open Space Provided</b>		
Mandela Plaza		30,032 SF
Under Track Plaza		8,464 SF
Art Alley		20,923 SF
Center Square		15,949 SF
		<b>75,368 SF</b>

**Note:**

The Applicant is requesting a waiver/reduction of the group usable open space requirements for T-1 and for T-3 pursuant to Government Code section 65915 (e); and

The Applicant is requesting a reduction in the amount of parking required for T-1 and T-3 pursuant to Government Code section 65915 (p)

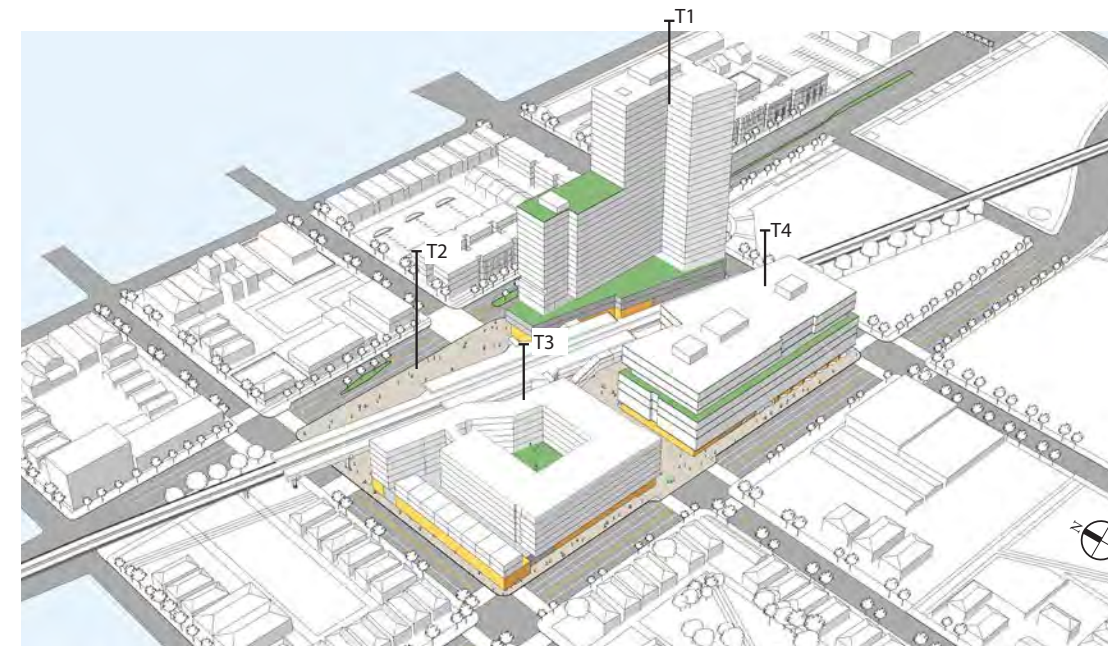

**MANDELA STATION  
@WEST OAKLAND  
BART**  
1451 7th St, Oakland,  
CA 94607

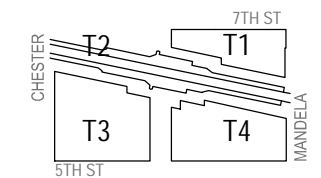

JRDV Architects, Inc  
The Cathedral Building  
Broadway and Telegraph  
PO Box 70126  
Oakland, CA 94612 USA  
510 295 4392 T  
www.jrdv.com



PROJ. # 168-153 WO BART  
DATE: July 24, 2020

**ZONING  
INFO**

SHEET:

**A-00.18**

GENERAL ZONING INFORMATION	REFERENCE	NOTES
ASSESORS BLOCK	Survey	See Survey; Tract 8046, Blocks 494 and 493
ZONING USE DISTRICT	Oak GIS	S-15W
PERMITTED AND/OR CONDITIONAL USES	17.97.010-.020	Residential, Community Assembly, General Retail, Full +Limited Service Retail, Parking, Commercial Office permitted
HEIGHT & BULK DISTRICT	17.97	S-15W 60' and S-15W 100'; master plan consistent with zoning requirements
GENERAL PLAN / POLICY PLAN	OAK-GIS	General Commercial; West Oakland Specific Plan
HISTORIC OR LANDMARK STATUS	OAK-GIS	None
LIQUEFACTION HAZARD ZONE	OAK-GIS	Severity 4
CONDO CONVERSION IMPACT AREA	OAK-GIS	None
<b>HEIGHT AND BULK CONTROLS</b>		
SITE AREA	Survey	241,282 SF
FLOOR AREA RATIO (FAR)	17.97.130	S-15W 60' - 3.0; S-15W 100' - 5.0; Master Plan within zoning density requirements
HEIGHT LIMIT	17.97	60' and 100' (Height limit modified to allow 80' and 320' tall building pursuant to State Affordable Housing Exemption)
REQUIRED SETBACKS	17.97.060	No Front Yard Setbacks Required; Interior Lot subject to PUD
REAR YARDS / COURTS		None Required
ADJACENCIES		None Significant
UNIT SEPARATION / EXPOSURE REQUIREMENTS	17.108.080	8' minimum at living room window +2' for each floor above = maximum 10% of It width
<b>DETAILED CONTROLS &amp; REQUIREMENTS</b>		
RESIDENTIAL DENSITY LIMITS	17.97.130	S-15W 60' - 375sf/unit; S-15W100' - 225sf/unit; Density increase per State Affordable Housing and PUD density bonus
OPEN SPACE REQUIREMENTS	17.97.130	S-15W 60' - 150sf/unit; and S-15W 100' - 75sf/unit; Overall master plan within zoning limites
SCREENING & SETBACK OF PARKING & LOADING	17.116.290	All parking garages are screened per zoning requirements
OFF-STREET PARKING - RESIDENTIAL	17.116.060	0.5 parking space per dwelling unit required; Parking meets zoning requirements with approved reductions
OFF-STREET PARKING - RETAIL	17.116.080	1 space/600 Sf of ground floor; Parking meets zoning requirements with approved reductions
OFF-STREET PARKING - COMMERCIAL	17.116.080	None required
OFF-STREET PARKING DIMENSIONS	17.116.200	50-50 compact / standard; or 75% intermediate + 12.5% compact
OFF-STREET DRIVE AISLE DIMENSIONS	17.116.210	21'-24' two way aisle widths
OFF-STREET LOADING - RESIDENTIAL	17.116.120	Loading per zoning requirements
OFF-STREET LOADING - RETAIL	17.116.150	Loading per zoning requirements
LOADING BERTH DIMENSIONS	17.116.220	10'x23', 12' high for residential activities, 10'x25', 8' high for undertaking service commercial activities
BICYCLE REQUIREMENTS - RESIDENTIAL+COMMERCIAL	17.117.090	LT: total 221 spaces; ST: total 54 spaces LT: 1 per 10,000 sf of commercial; ST: 1 per 20,000 sf of commercial LT: 0.25 spaces per dwelling unit; ST: 0.05 per dwelling unit; bicycle parking provide per zoning code
BICYCLE REQUIREMENTS - RETAIL	17.117.110	LT: total 6 spaces; ST: total 28 spaces LT: 1 per 12k; ST: 1 per 2k; bicycle parking provided per zoning code



**MANDELA STATION  
@WEST OAKLAND  
BART**  
1451 7th St, Oakland,  
CA 94607

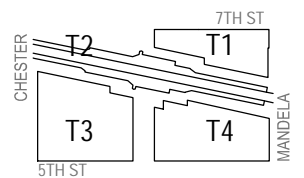

JRDV Architects, Inc  
The Cathedral Building  
Broadway and Telegraph  
PO Box 70126  
Oakland, CA 94612 USA  
510 295 4392 T  
www.jrdv.com



PROJ. # 168-153 WO BART  
DATE: July 24, 2020

# ZONING SUMMARY

SHEET:

A-00.19



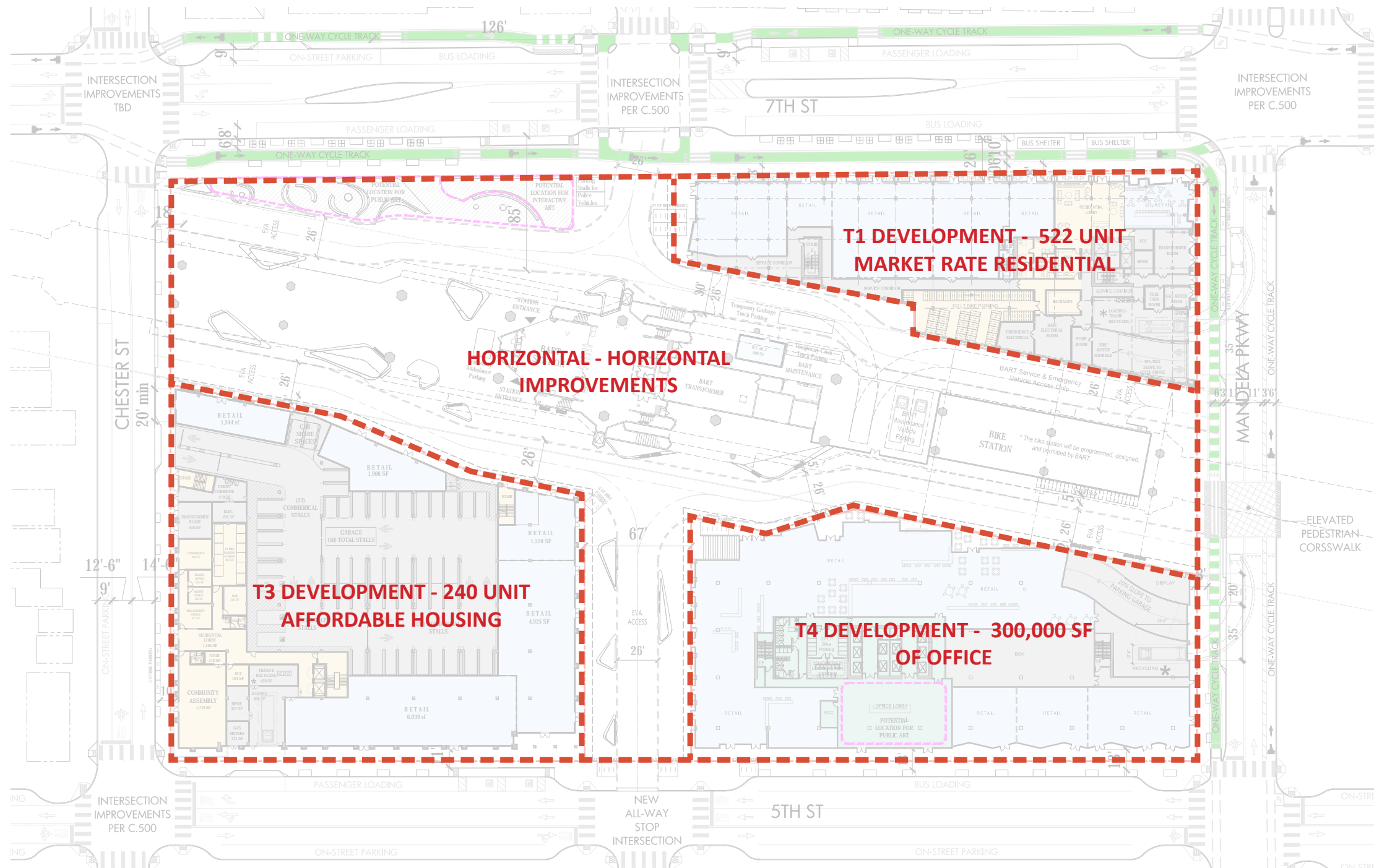

**MANDELA STATION  
 @WEST OAKLAND  
 BART**  
 1451 7th St, Oakland,  
 CA 94607

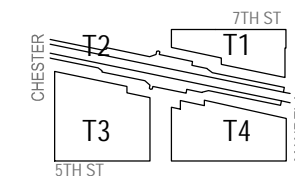

**PROJECT SCHEDULE**

1. Horizontal

i.	Submit application for Final Development Plan	1 year following PDP approval	
ii.	Anticipated FDP approval date by Agency	1 year following submittal of Horizontal FDP application	
iii.	Commence construction – Initial PX and/or PZ job (additional PX and PZ jobs will be tied to each later phase)	2 years following FDP approval	

2. Phase I – T3 Development (plus PZ/PX for that phase)

i.	Submit application for Final Development Plan	1 year following PDP approval	
ii.	Anticipated FDP approval date by Agency	1 year following submittal of Phase I FDP application	
iii.	Commence construction	2 years following FDP approval (allowing time to secure affordable financing)	

3. Phase II – T1 Development & T2 Development (plus PZ/PX for that phase)

i.	Submit application for Final Development Plan	3 years following PDP approval	
ii.	Anticipated FDP approval date by Agency	1 year following submittal of Phase II FDP application	
iii.	Commence construction	The latter of 2 years following FDP approval or 2 years following Phase I commencement of construction	

4. Phase III – T4 Development (plus PZ/PX for that phase)

i.	Submit application for Final Development Plan	5 years following PDP approval	
ii.	Anticipated FDP approval date by Agency	1 year following submittal of Phase III FDP application	
iii.	Commence construction	The latter of 2 years following FDP approval or 2 years following Phase II commencement of construction	

PROJ. # 168-153 WO BART

DATE: July 24, 2020

**PHASING  
 PLAN**

SHEET:

**A-00.20**

All dates are subject to force majeure events

01 SCHEDULE:      wks

Total Parking: 377

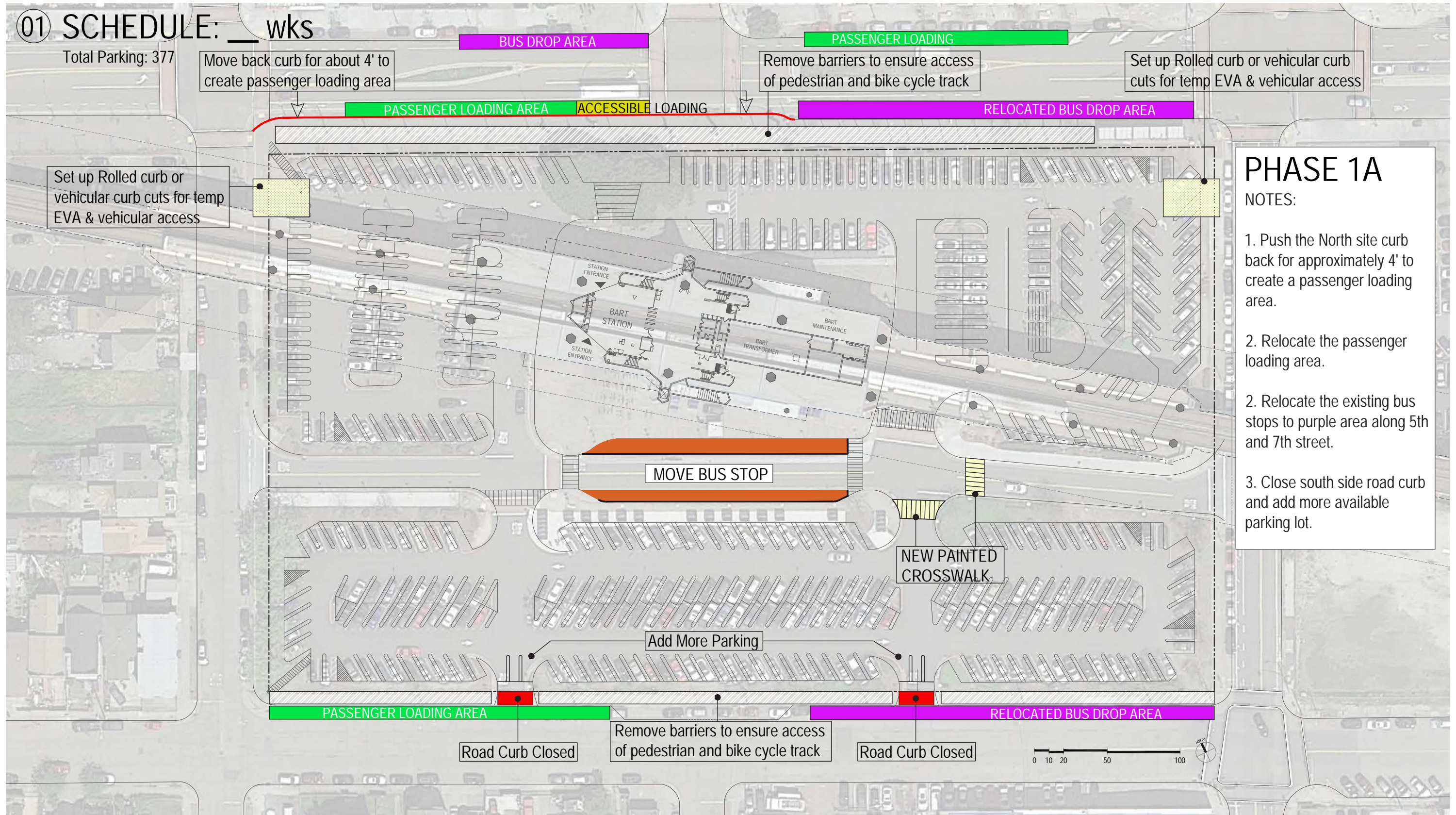

PHASE 1A

NOTES:

1. Push the North site curb back for approximately 4' to create a passenger loading area.
2. Relocate the passenger loading area.
2. Relocate the existing bus stops to purple area along 5th and 7th street.
3. Close south side road curb and add more available parking lot.

\*Refinements of the Phasing Plan will be incorporated into the project's CMP and that plan will include refinements to the site logistics plan, traffic control plan, and pedestrian and bike access plan, in order to minimize potential construction impacts and coordinate the various phases. Pursuant to COA #13, the CMP will be submitted to the City for review and approval by the Bureau of Planning, Bureau of Building, and other relevant City departments, including the Fire Department, Department of Transportation, and the Public Works Department.

\*The off-site phasing will be determined based on the Construction Management Plans. The

off-site phasing will be complete prior to the Certificate of Occupancy of T1.

\*Accommodating a pedestrian walkway and in-lane bicycle facility on 7th Street and Mandela Pkwy during the construction period of T1 may be accommodated, but it may require changes to the street lanes during construction which need to be studied by the developer and DOT and documented in the Construction Management Plan.

\* The developer will work with the City to designate a bus stop for intercity coaches (e.g., Megabus and Bolt) and other shuttles on 7th Street between Henry and Chester Streets.

02 SCHEDULE:      wks

Total Parking: 377

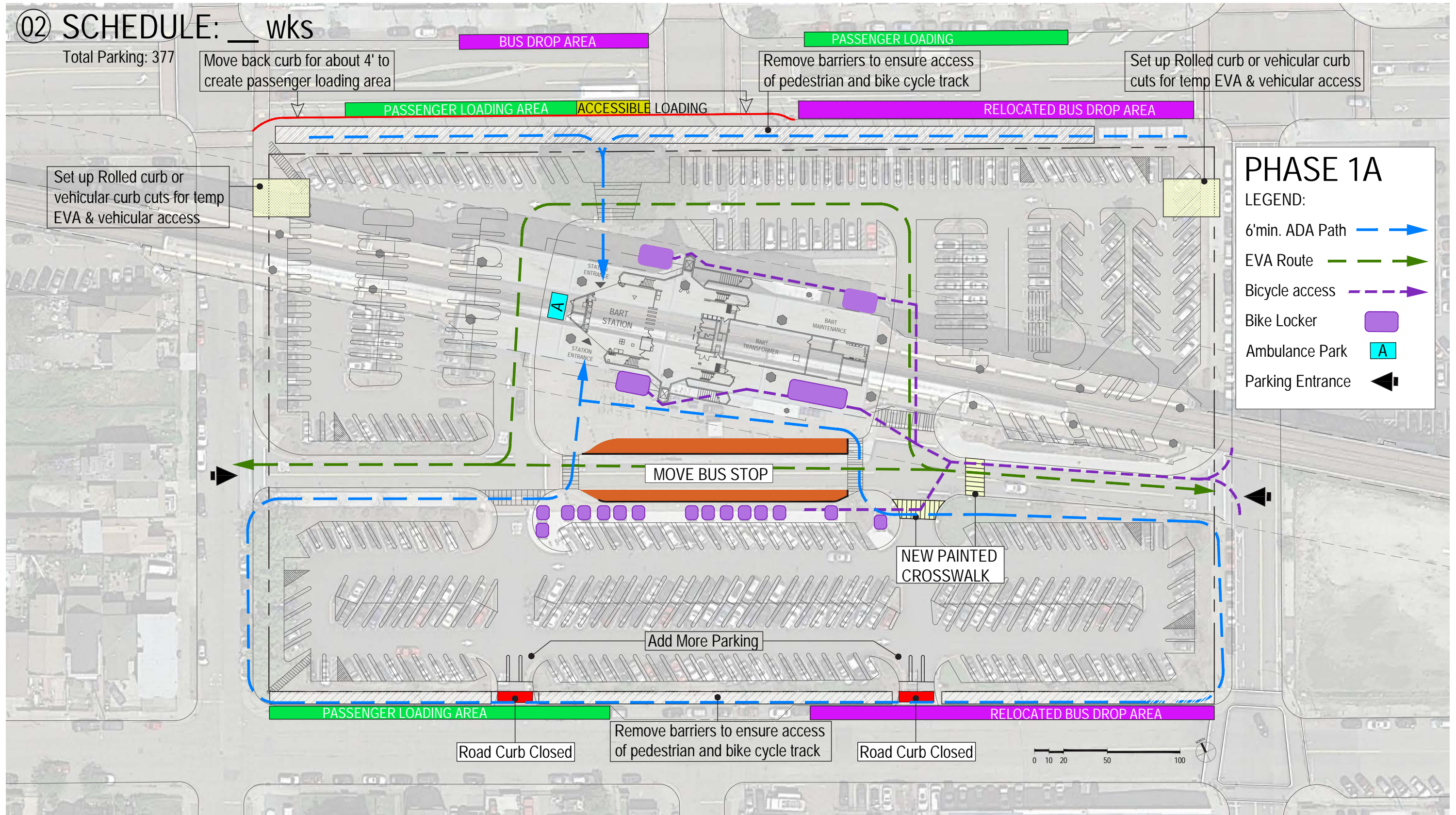

\*Refinements of the Phasing Plan will be incorporated into the project's CMP and that plan will include refinements to the site logistics plan, traffic control plan, and pedestrian and bike access plan, in order to minimize potential construction impacts and coordinate the various phases. Pursuant to COA #13, the CMP will be submitted to the City for review and approval by the Bureau of Planning, Bureau of Building, and other relevant City departments, including the Fire Department, Department of Transportation, and the Public Works Department.

\*The off-site phasing will be determined based on the Construction Management Plans. The

off-site phasing will be complete prior to the Certificate of Occupancy of T1.

\*Accommodating a pedestrian walkway and in-lane bicycle facility on 7th Street and Mandela Pkwy during the construction period of T1 may be accommodated, but it may require changes to the street lanes during construction which need to be studied by the developer and DOT and documented in the Construction Management Plan.

\*The developer will work with the City to designate a bus stop for intercity coaches (e.g., Megabus and Bolt) and other shuttles on 7th Street between Henry and Chester Streets.

PHASE 1A  
REORGANIZED ROUTES

A-11.02

03 SCHEDULE:      wks

Total Parking: 229

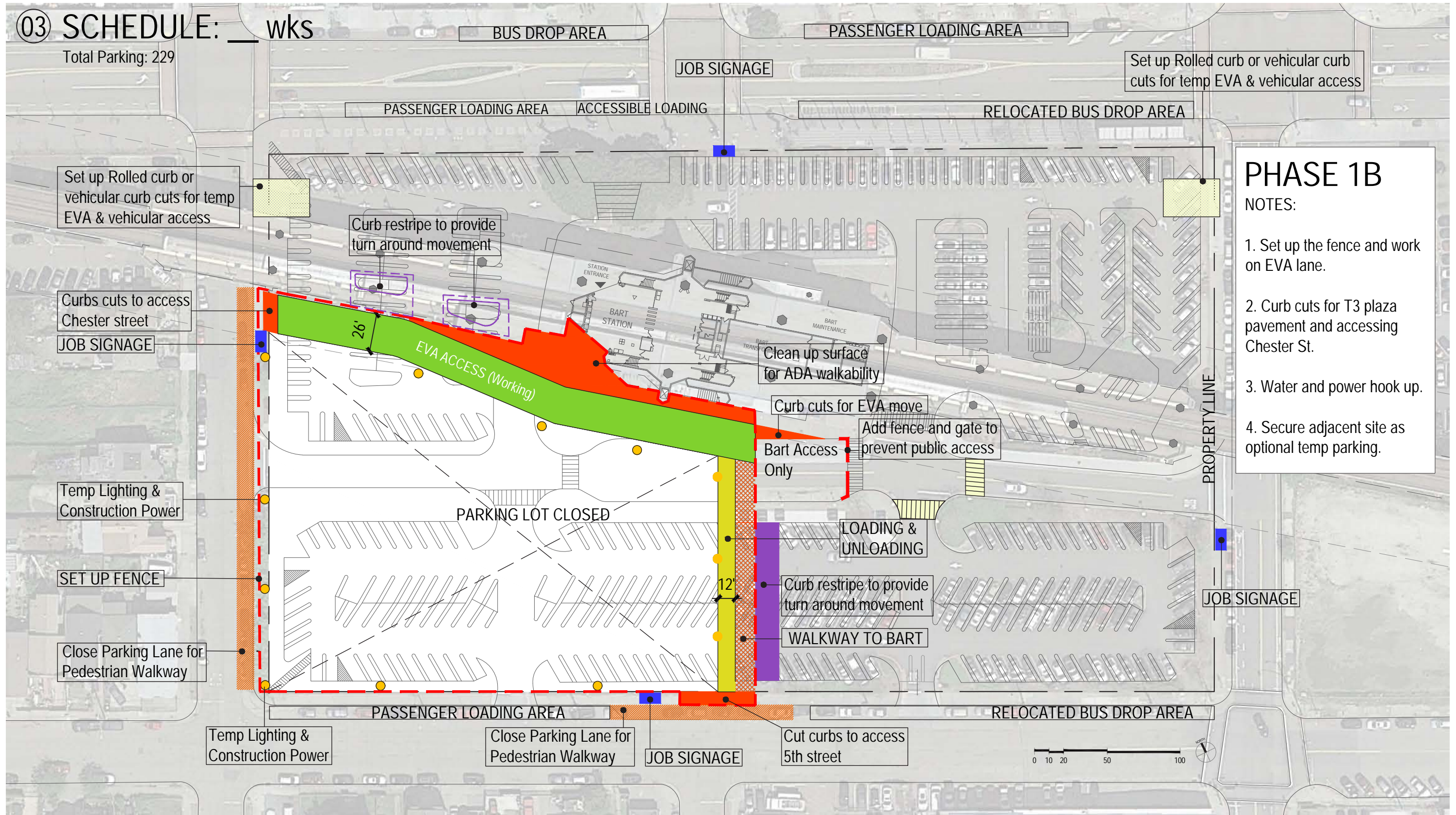

PHASE 1B

NOTES:

1. Set up the fence and work on EVA lane.
2. Curb cuts for T3 plaza pavement and accessing Chester St.
3. Water and power hook up.
4. Secure adjacent site as optional temp parking.

\*Refinements of the Phasing Plan will be incorporated into the project's CMP and that plan will include refinements to the site logistics plan, traffic control plan, and pedestrian and bike access plan, in order to minimize potential construction impacts and coordinate the various phases. Pursuant to COA #13, the CMP will be submitted to the City for review and approval by the Bureau of Planning, Bureau of Building, and other relevant City departments, including the Fire Department, Department of Transportation, and the Public Works Department.

\* The off-site phasing will be determined based on the Construction Management Plans. The off-site phasing will be complete prior to the Certificate of Occupancy of T1.

PHASE 1B  
T3 SITE PREPARATION

A-11.03

04 SCHEDULE:      wks

Total Parking: 229

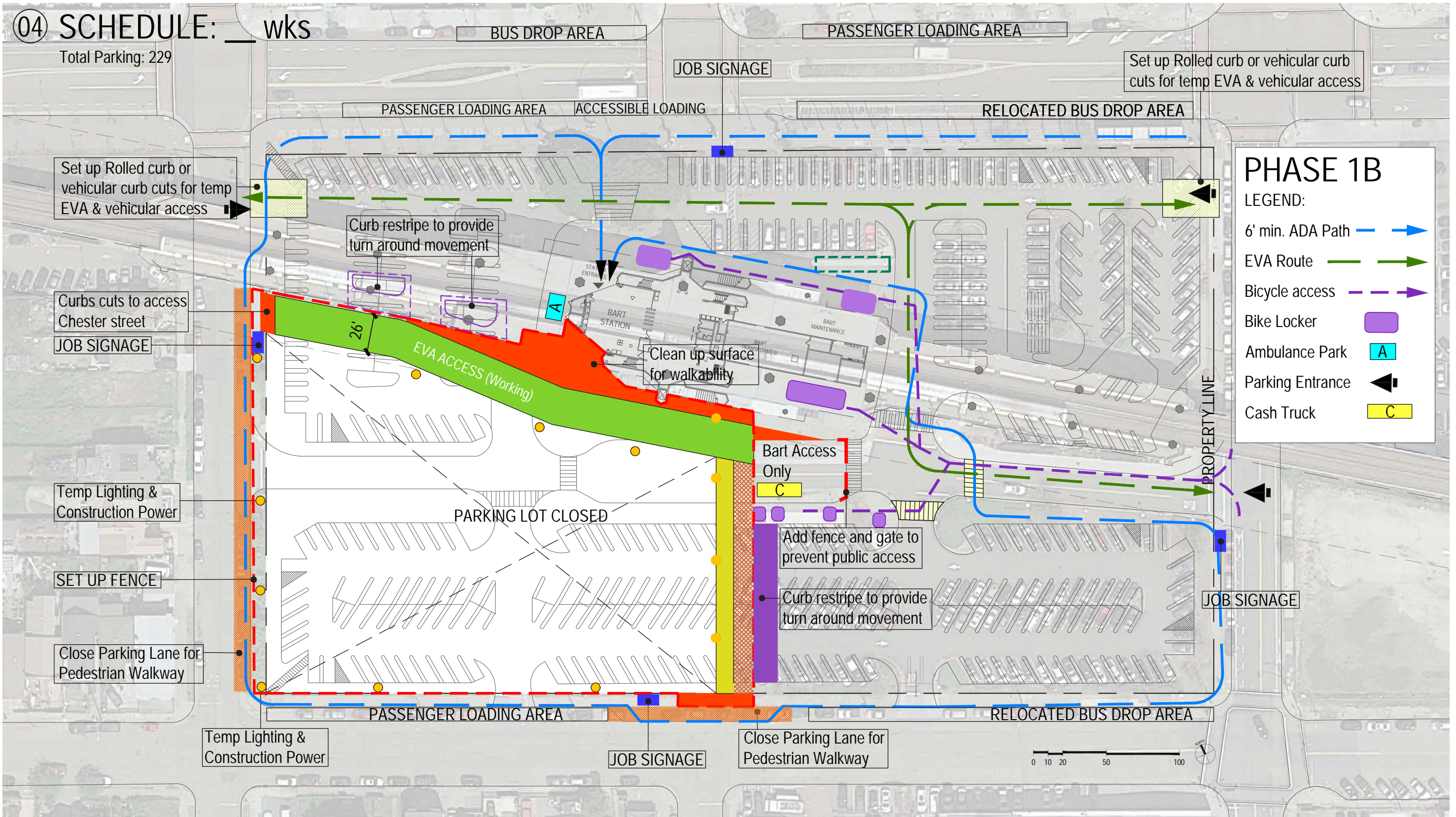

**PHASE 1B**

LEGEND:

- 6' min. ADA Path ———▶
- EVA Route ———▶
- Bicycle access - - - -▶
- Bike Locker [Purple Box]
- Ambulance Park [Cyan Box 'A']
- Parking Entrance [Black Arrow]
- Cash Truck [Yellow Box 'C']

\*Refinements of the Phasing Plan will be incorporated into the project's CMP and that plan will include refinements to the site logistics plan, traffic control plan, and pedestrian and bike access plan, in order to minimize potential construction impacts and coordinate the various phases. Pursuant to COA #13, the CMP will be submitted to the City for review and approval by the Bureau of Planning, Bureau of Building, and other relevant City departments, including the Fire Department, Department of Transportation, and the Public Works Department.

\* The off-site phasing will be determined based on the Construction Management Plans. The off-site phasing will be complete prior to the Certificate of Occupancy of T1.

05 SCHEDULE: wks

Total Parking: 229

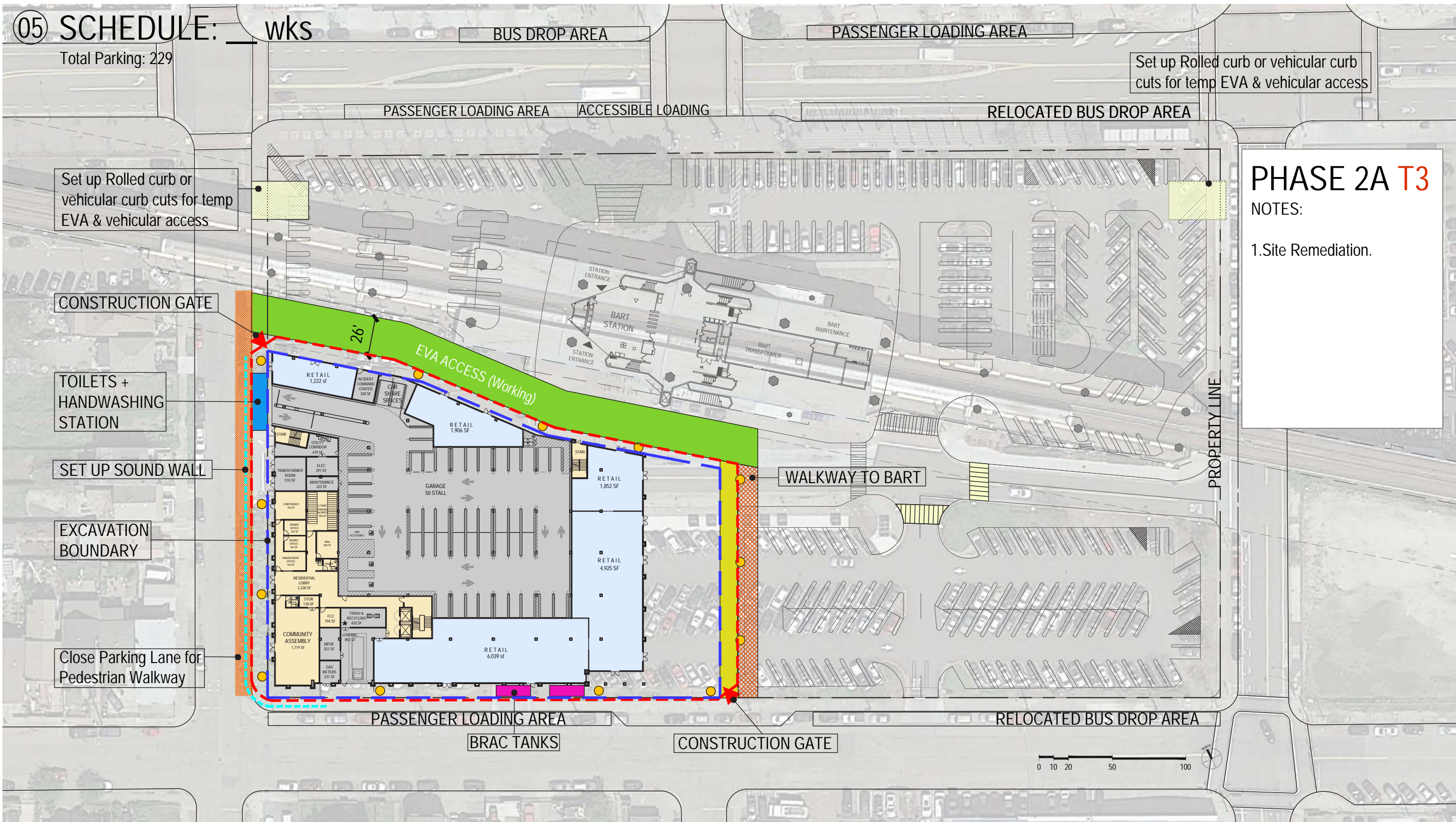

PHASE 2A T3

NOTES:

- 1. Site Remediation.

\*Refinements of the Phasing Plan will be incorporated into the project's CMP and that plan will include refinements to the site logistics plan, traffic control plan, and pedestrian and bike access plan, in order to minimize potential construction impacts and coordinate the various phases. Pursuant to COA #13, the CMP will be submitted to the City for review and approval by the Bureau of Planning, Bureau of Building, and other relevant City departments, including the Fire Department, Department of Transportation, and the Public Works Department.

\* The off-site phasing will be determined based on the Construction Management Plans. The off-site phasing will be complete prior to the Certificate of Occupancy of T1.

06 SCHEDULE: wks

Total Parking: 229

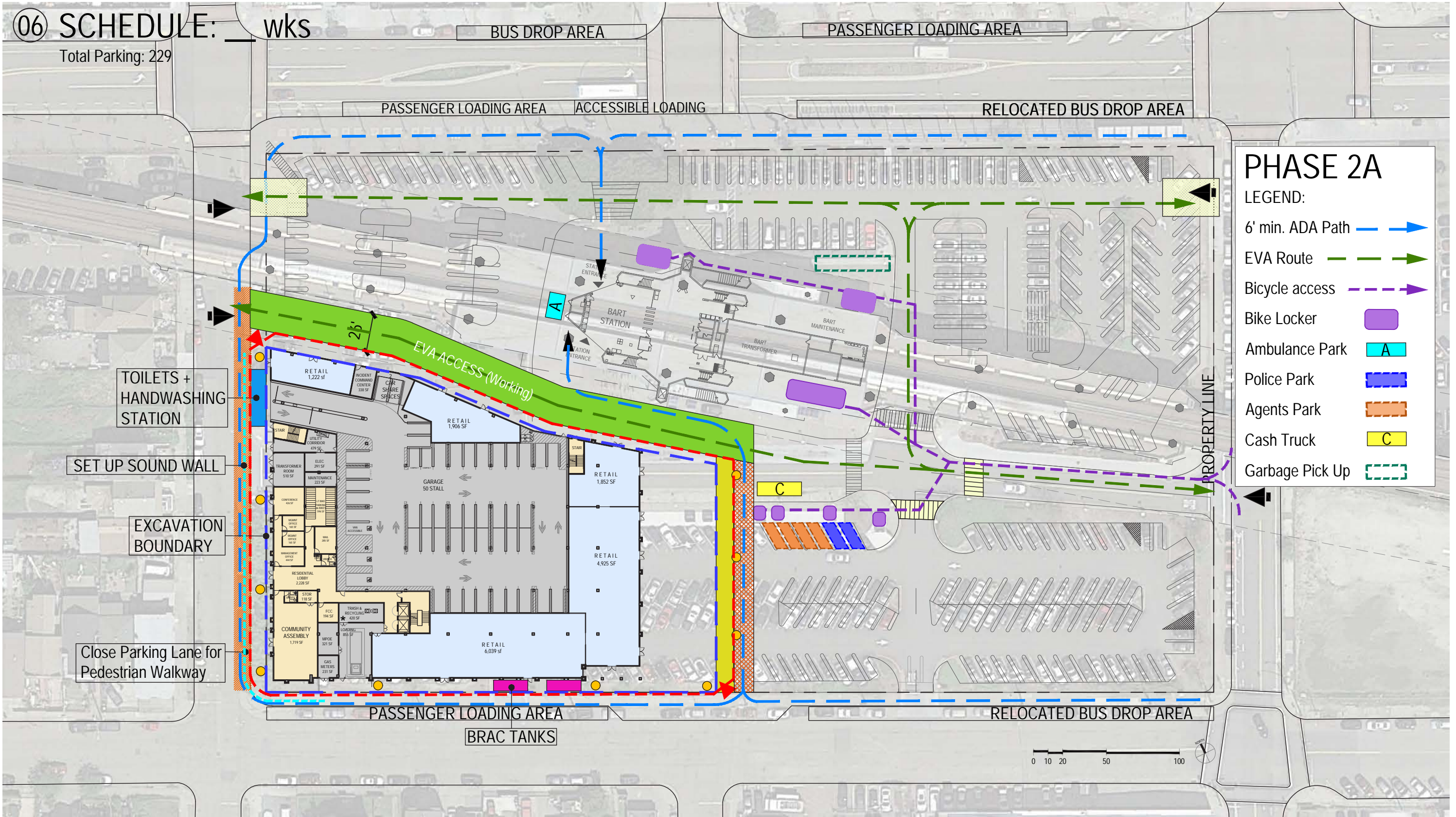

### PHASE 2A

LEGEND:

- 6' min. ADA Path — — — — — ➔
- EVA Route — — — — — ➔
- Bicycle access — — — — — ➔
- Bike Locker
- Ambulance Park  A
- Police Park  B
- Agents Park  C
- Cash Truck  D
- Garbage Pick Up

\*Refinements of the Phasing Plan will be incorporated into the project's CMP and that plan will include refinements to the site logistics plan, traffic control plan, and pedestrian and bike access plan, in order to minimize potential construction impacts and coordinate the various phases. Pursuant to COA #13, the CMP will be submitted to the City for review and approval by the Bureau of Planning, Bureau of Building, and other relevant City departments, including the Fire Department, Department of Transportation, and the Public Works Department.

\* The off-site phasing will be determined based on the Construction Management Plans. The off-site phasing will be complete prior to the Certificate of Occupancy of T1.

**07 SCHEDULE:**      wks

Total Parking: 229

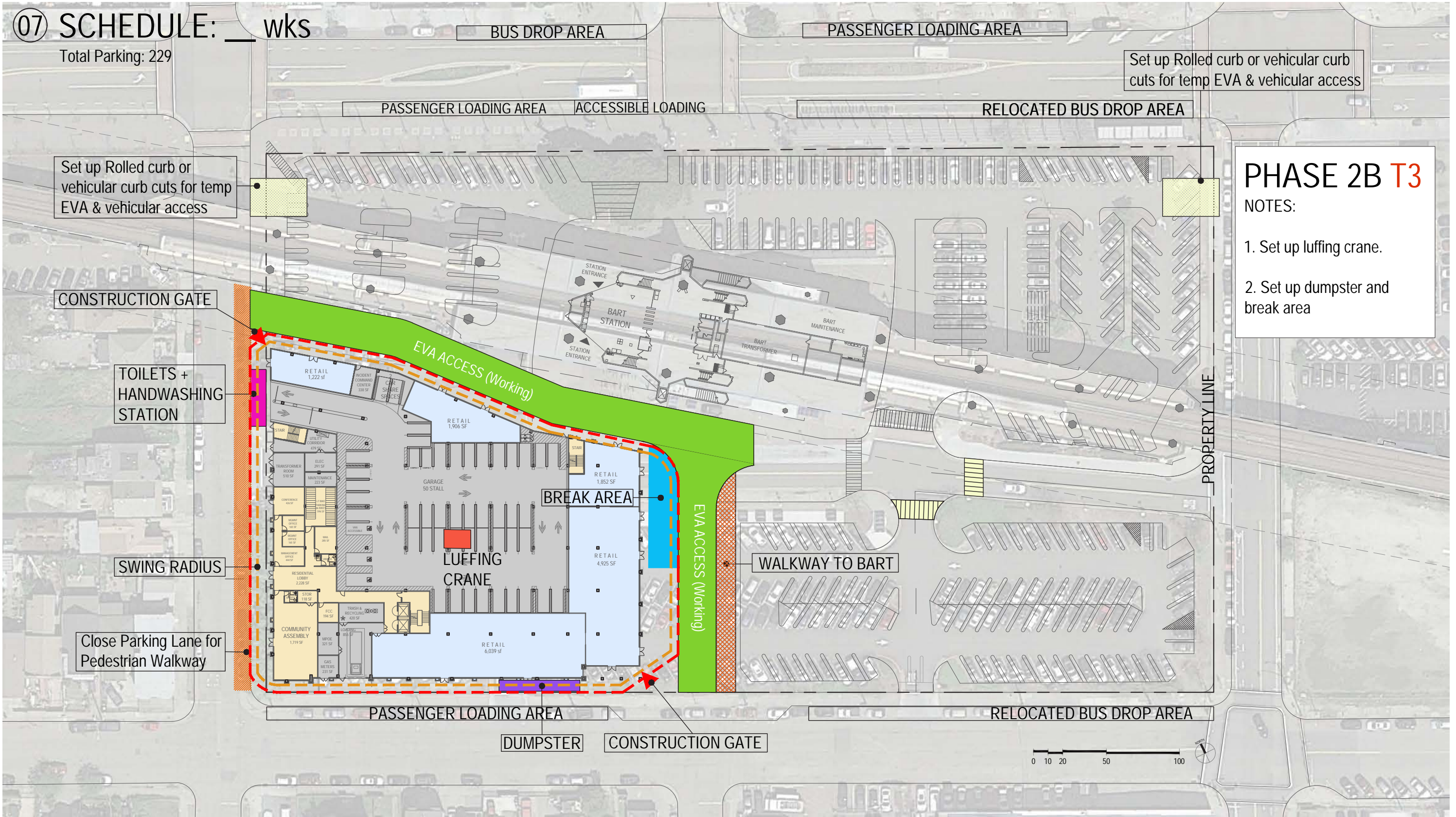

Set up Rolled curb or vehicular curb cuts for temp EVA & vehicular access

Set up Rolled curb or vehicular curb cuts for temp EVA & vehicular access

**PHASE 2B T3**

- NOTES:
1. Set up luffing crane.
  2. Set up dumpster and break area

\*Refinements of the Phasing Plan will be incorporated into the project's CMP and that plan will include refinements to the site logistics plan, traffic control plan, and pedestrian and bike access plan, in order to minimize potential construction impacts and coordinate the various phases. Pursuant to COA #13, the CMP will be submitted to the City for review and approval by the Bureau of Planning, Bureau of Building, and other relevant City departments, including the Fire Department, Department of Transportation, and the Public Works Department.

\* The off-site phasing will be determined based on the Construction Management Plans. The off-site phasing will be complete prior to the Certificate of Occupancy of T1.



08 SCHEDULE:      wks

Total Parking: 229

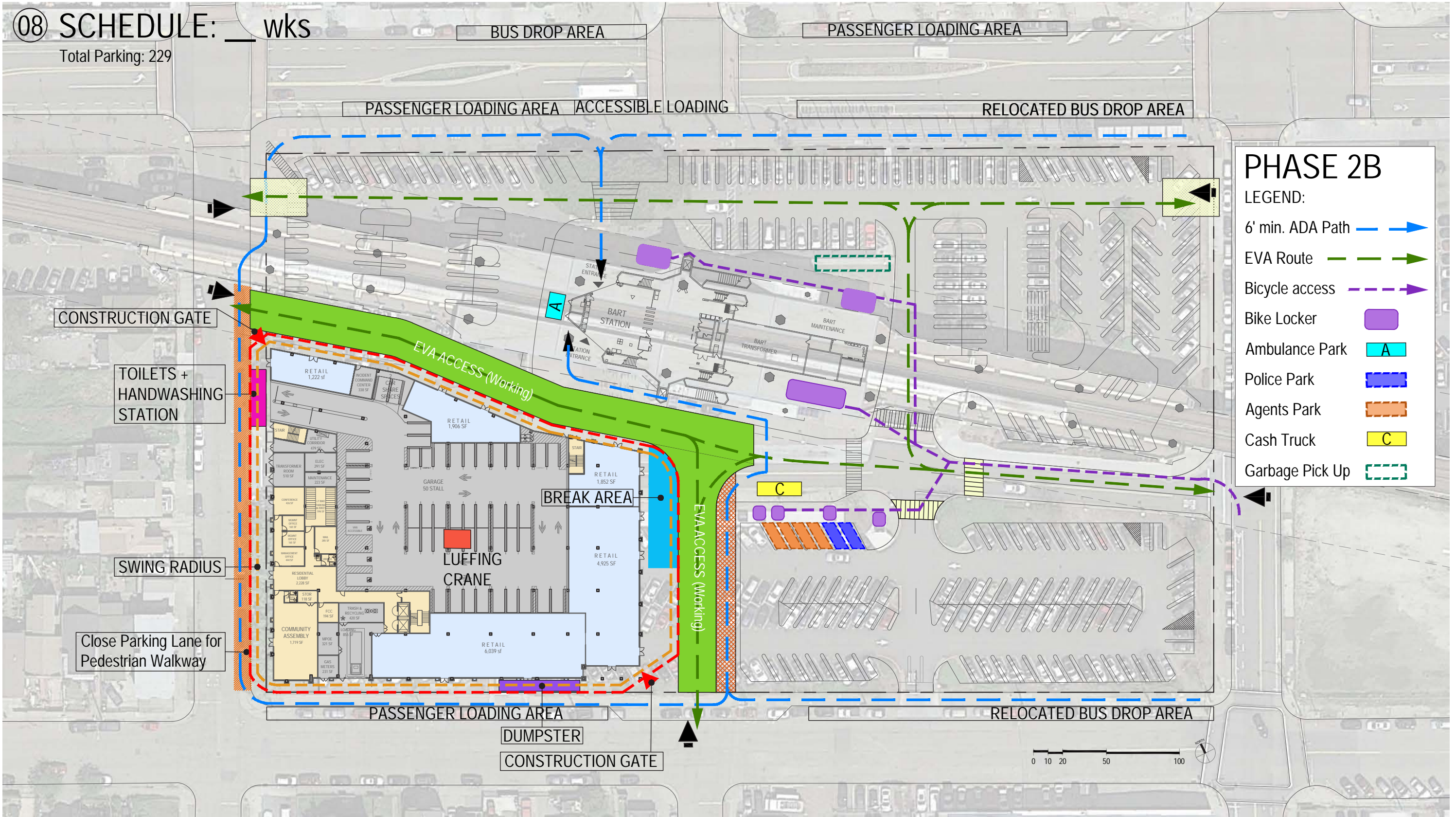

### PHASE 2B

LEGEND:

- 6' min. ADA Path —▶
- EVA Route - -▶
- Bicycle access - -▶
- Bike Locker ■
- Ambulance Park ■ A
- Police Park ■
- Agents Park ■
- Cash Truck ■ C
- Garbage Pick Up - -

\*Refinements of the Phasing Plan will be incorporated into the project's CMP and that plan will include refinements to the site logistics plan, traffic control plan, and pedestrian and bike access plan, in order to minimize potential construction impacts and coordinate the various phases. Pursuant to COA #13, the CMP will be submitted to the City for review and approval by the Bureau of Planning, Bureau of Building, and other relevant City departments, including the Fire Department, Department of Transportation, and the Public Works Department.

\* The off-site phasing will be determined based on the Construction Management Plans. The off-site phasing will be complete prior to the Certificate of Occupancy of T1.

PHASE 2B  
REORGANIZED ROUTES

09 SCHEDULE:      wks

Total Parking: 229

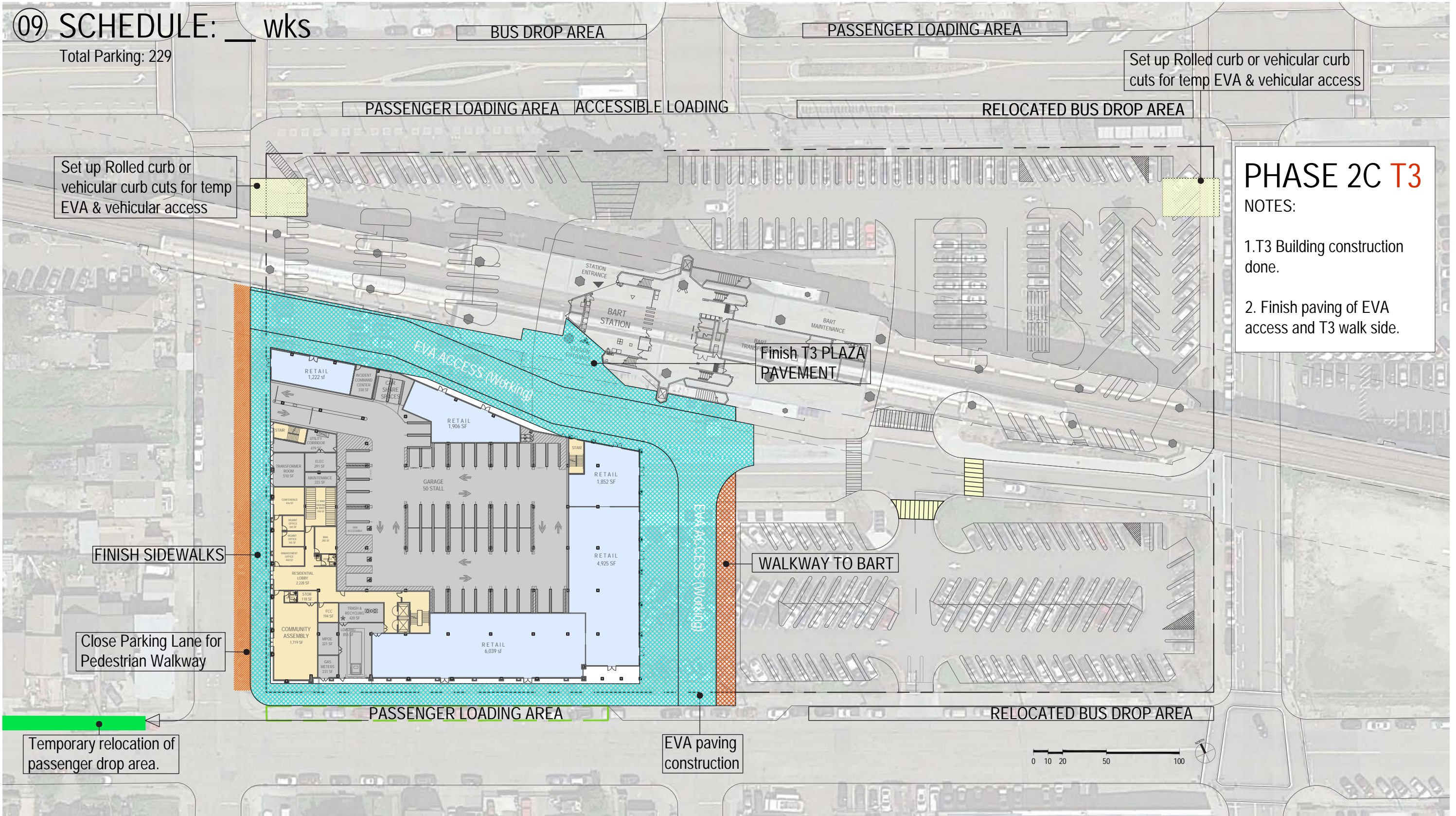

**PHASE 2C T3**

NOTES:

1. T3 Building construction done.
2. Finish paving of EVA access and T3 walk side.

\*Refinements of the Phasing Plan will be incorporated into the project's CMP and that plan will include refinements to the site logistics plan, traffic control plan, and pedestrian and bike access plan, in order to minimize potential construction impacts and coordinate the various phases. Pursuant to COA #13, the CMP will be submitted to the City for review and approval by the Bureau of Planning, Bureau of Building, and other relevant City departments, including the Fire Department, Department of Transportation, and the Public Works Department.

\* The off-site phasing will be determined based on the Construction Management Plans. The off-site phasing will be complete prior to the Certificate of Occupancy of T1.

⑩ SCHEDULE:      wks

Total Parking: 229

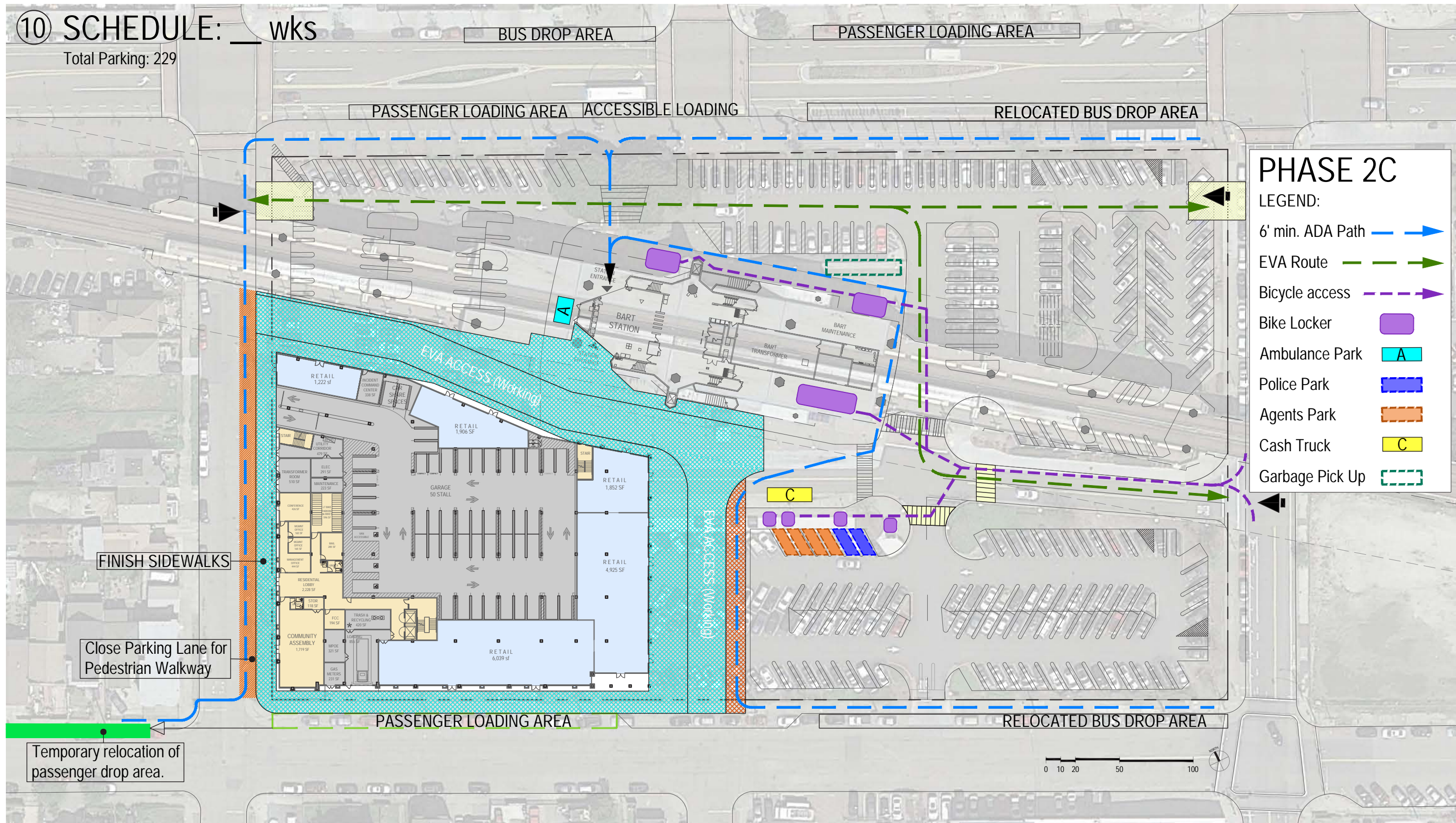

**PHASE 2C**  
**LEGEND:**  
 6' min. ADA Path ———▶  
 EVA Route ———▶  
 Bicycle access ———▶  
 Bike Locker [Purple Box]  
 Ambulance Park [A Box]  
 Police Park [Blue Box]  
 Agents Park [Orange Box]  
 Cash Truck [C Box]  
 Garbage Pick Up [Dashed Box]

FINISH SIDEWALKS

Close Parking Lane for Pedestrian Walkway

Temporary relocation of passenger drop area.

\*Refinements of the Phasing Plan will be incorporated into the project's CMP and that plan will include refinements to the site logistics plan, traffic control plan, and pedestrian and bike access plan, in order to minimize potential construction impacts and coordinate the various phases. Pursuant to COA #13, the CMP will be submitted to the City for review and approval by the Bureau of Planning, Bureau of Building, and other relevant City departments, including the Fire Department, Department of Transportation, and the Public Works Department.

\* The off-site phasing will be determined based on the Construction Management Plans. The off-site phasing will be complete prior to the Certificate of Occupancy of T1.

11 SCHEDULE:      wks

Total Parking: 229

Temporary relocation of passenger drop area.

BUS DROP AREA

PASSENGER LOADING AREA

RELOCATED BUS DROP AREA

FINISH PLAZA SIDEWALK

PHASE 3A T2

NOTES:

1. Temporary relocate the passenger drop area.
2. Finish T2 plaza side walk.

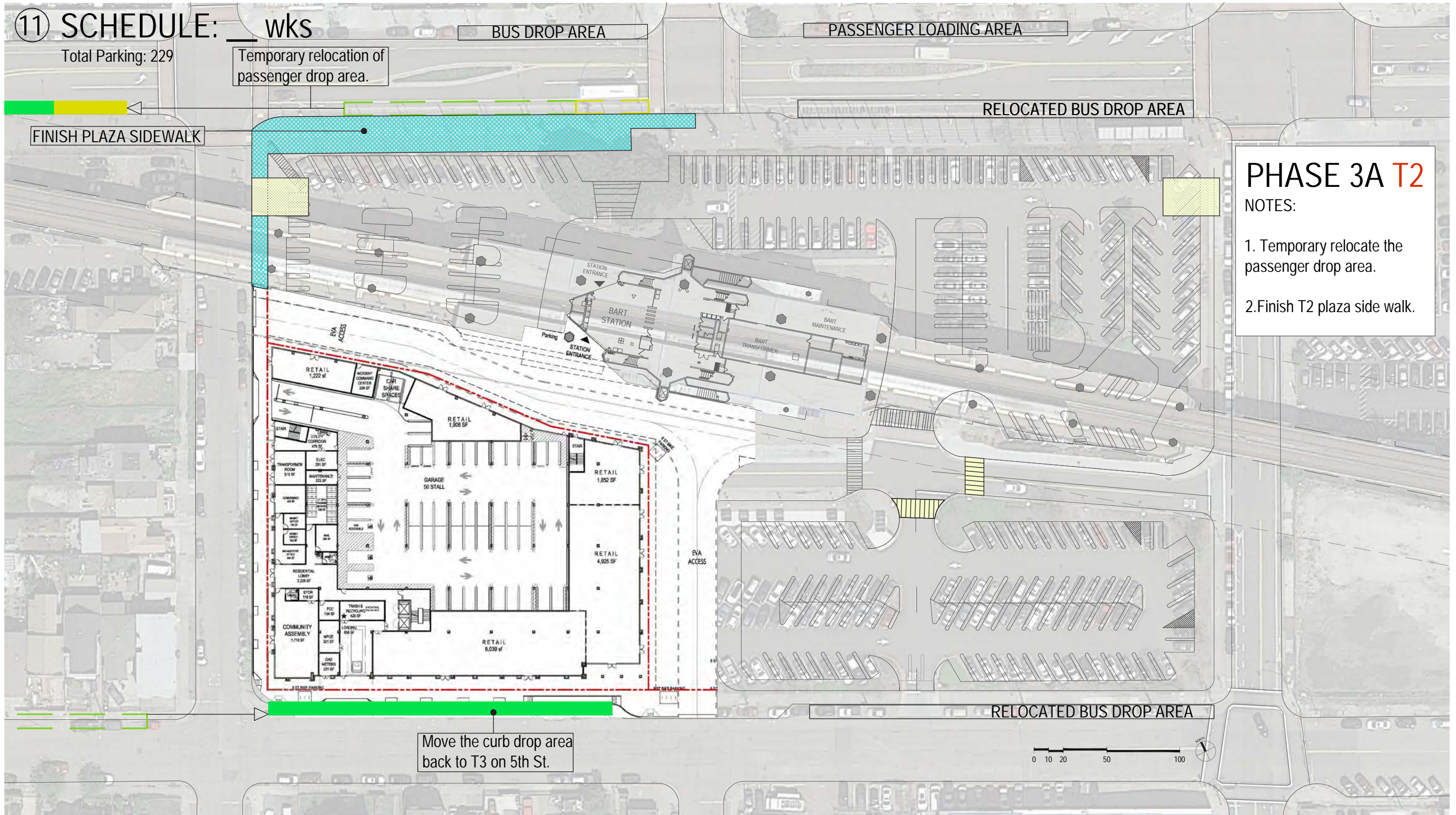

Move the curb drop area back to T3 on 5th St.

\*Refinements of the Phasing Plan will be incorporated into the project's CMP and that plan will include refinements to the site logistics plan, traffic control plan, and pedestrian and bike access plan, in order to minimize potential construction impacts and coordinate the various phases. Pursuant to COA #13, the CMP will be submitted to the City for review and approval by the Bureau of Planning, Bureau of Building, and other relevant City departments, including the Fire Department, Department of Transportation, and the Public Works Department.

\* The off-site phasing will be determined based on the Construction Management Plans. The off-site phasing will be complete prior to the Certificate of Occupancy of T1.

PHASE 3A FINISH  
T2 PAVING OF SIDE WALK

A-11.11

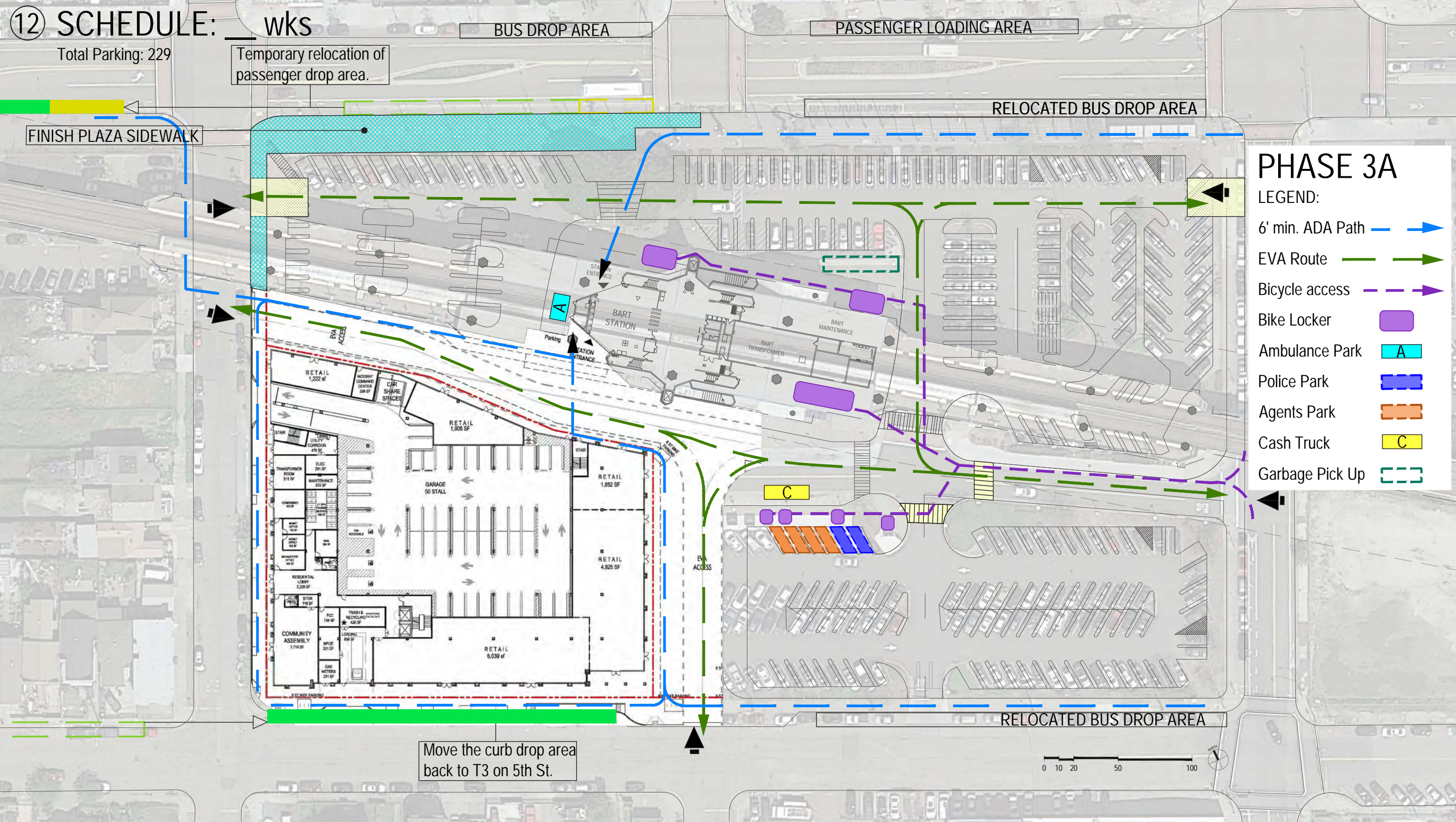

\*Refinements of the Phasing Plan will be incorporated into the project's CMP and that plan will include refinements to the site logistics plan, traffic control plan, and pedestrian and bike access plan, in order to minimize potential construction impacts and coordinate the various phases. Pursuant to COA #13, the CMP will be submitted to the City for review and approval by the Bureau of Planning, Bureau of Building, and other relevant City departments, including the Fire Department, Department of Transportation, and the Public Works Department.

\* The off-site phasing will be determined based on the Construction Management Plans. The off-site phasing will be complete prior to the Certificate of Occupancy of T1.

PHASE 3A  
 REORGANIZED ROUTES  
 A-11.12

13 SCHEDULE:      wks

Total Parking: 186

BUS DROP AREA

PASSENGER LOADING AREA

Move the curb drop area back to T2 on 7th St.

RELOCATED BUS DROP AREA

Cut curbs and work on plaza pavement

Set up fence to prevent public access

CONSTRUCTION GATE

SET UP FENCE

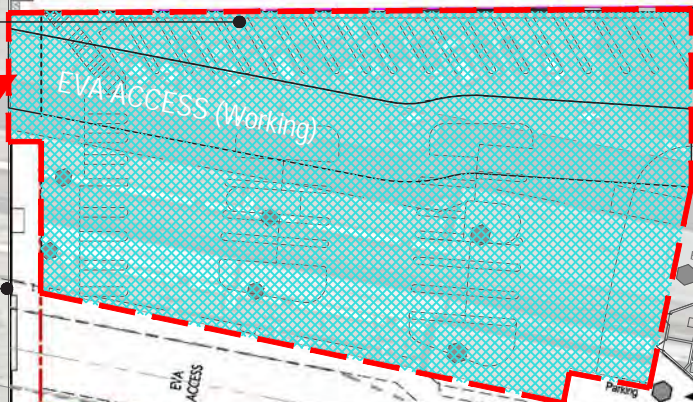

**PHASE 3B T2**

NOTES:

1. Set up fence
2. Cut curbs and work on plaza pavement.
3. Set up EVA roads

\*Refinements of the Phasing Plan will be incorporated into the project's CMP and that plan will include refinements to the site logistics plan, traffic control plan, and pedestrian and bike access plan, in order to minimize potential construction impacts and coordinate the various phases. Pursuant to COA #13, the CMP will be submitted to the City for review and approval by the Bureau of Planning, Bureau of Building, and other relevant City departments, including the Fire Department, Department of Transportation, and the Public Works Department.

\* The off-site phasing will be determined based on the Construction Management Plans. The off-site phasing will be complete prior to the Certificate of Occupancy of T1.

14 SCHEDULE:      wks

Total Parking: 186

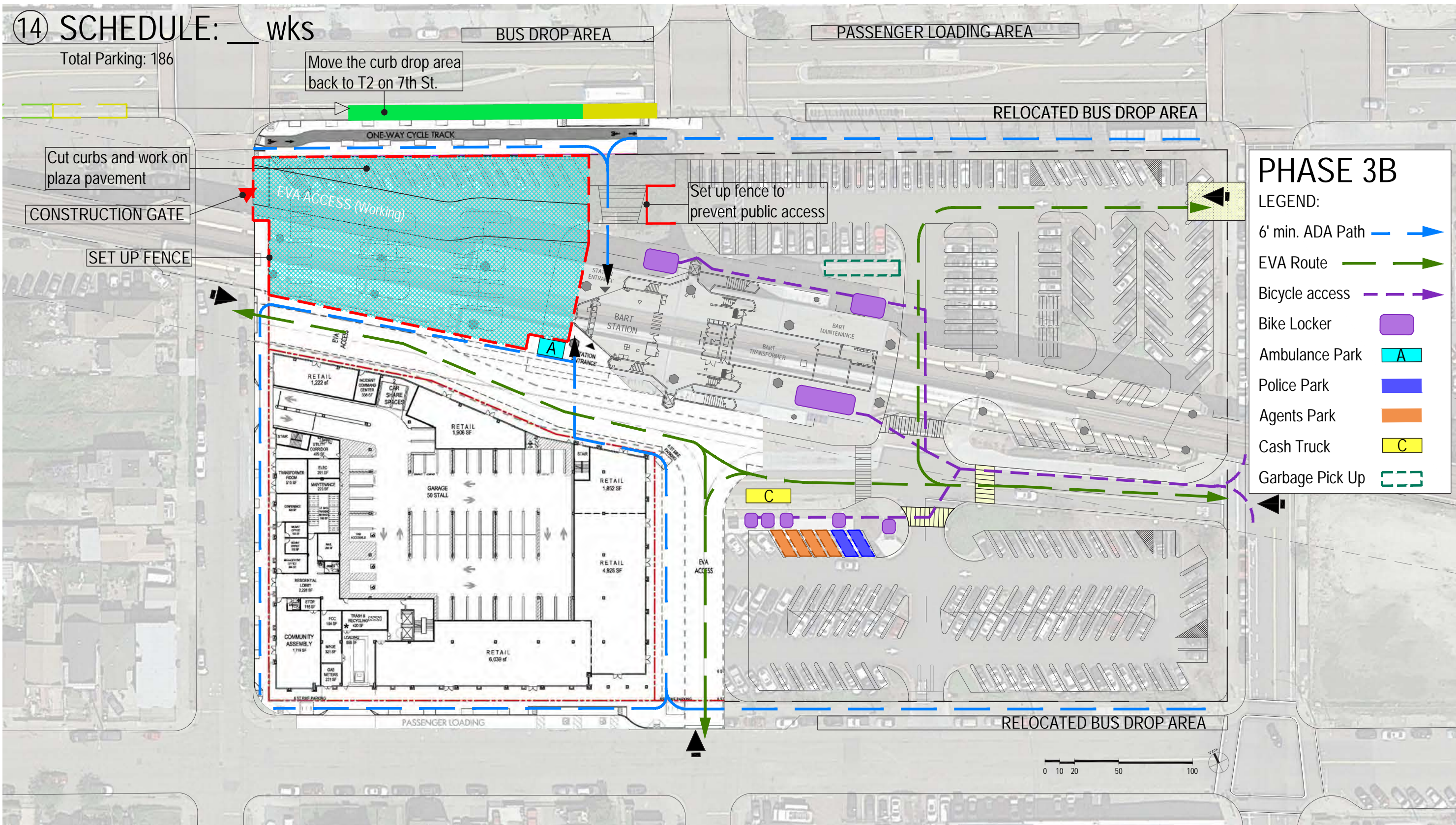

\*Refinements of the Phasing Plan will be incorporated into the project's CMP and that plan will include refinements to the site logistics plan, traffic control plan, and pedestrian and bike access plan, in order to minimize potential construction impacts and coordinate the various phases. Pursuant to COA #13, the CMP will be submitted to the City for review and approval by the Bureau of Planning, Bureau of Building, and other relevant City departments, including the Fire Department, Department of Transportation, and the Public Works Department.

\* The off-site phasing will be determined based on the Construction Management Plans. The off-site phasing will be complete prior to the Certificate of Occupancy of T1.

PHASE 3B  
REORGANIZED ROUTES

A-11.14

**15 SCHEDULE:** **wks**

Total Parking: 87

**PHASE 4A T2**

**NOTES:**

1. Set up fence
2. Cut curbs and work on rest of plaza pavement.
3. Build up Temp lighting, power and signage.
4. Cut curbs for EVA access to MANDLA PKWY.

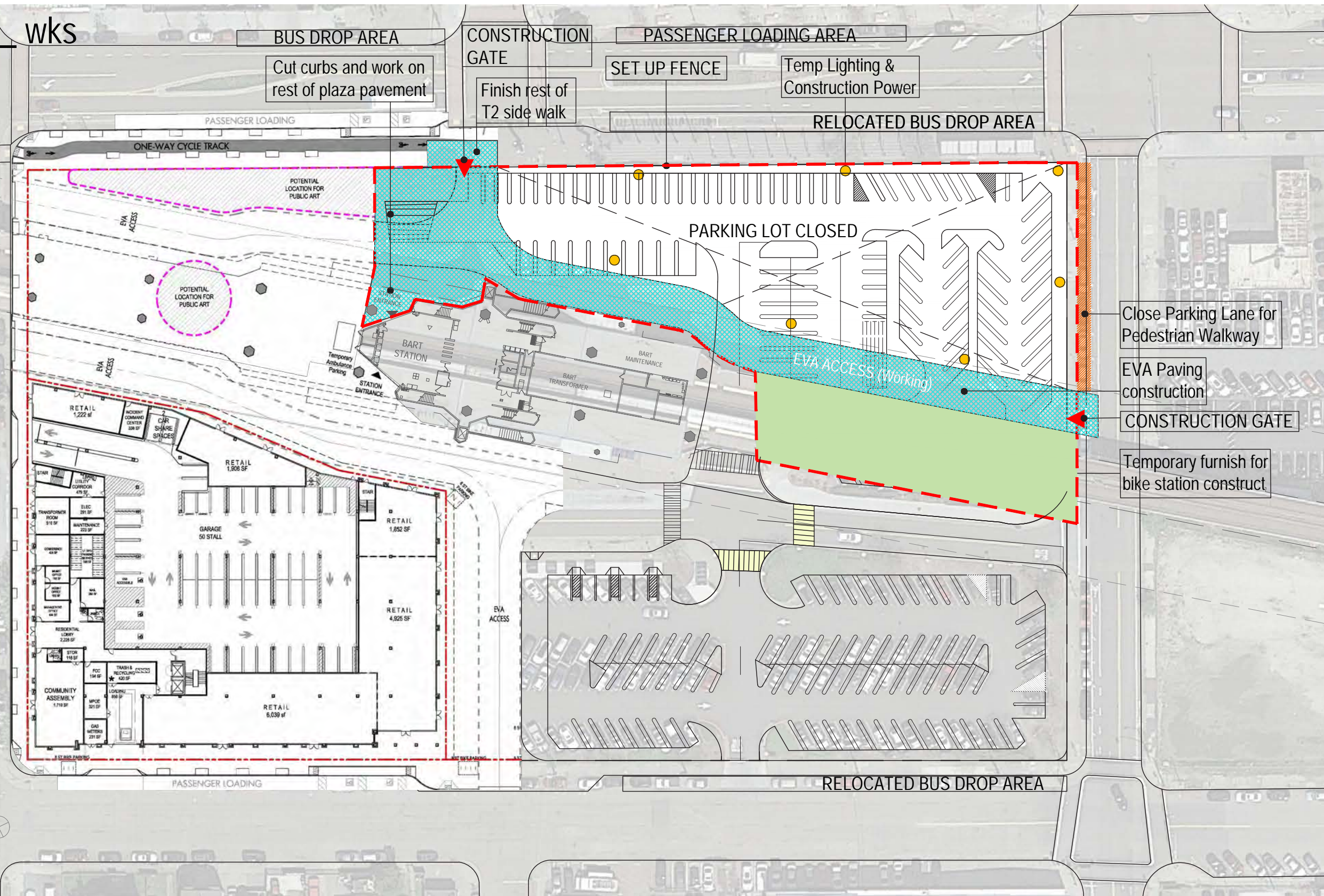

\*Refinements of the Phasing Plan will be incorporated into the project's CMP and that plan will include refinements to the site logistics plan, traffic control plan, and pedestrian and bike access plan, in order to minimize potential construction impacts and coordinate the various phases. Pursuant to COA #13, the CMP will be submitted to the City for review and approval by the Bureau of Planning, Bureau of Building, and other relevant City departments, including the Fire Department, Department of Transportation, and the Public Works Department.

\* The off-site phasing will be determined based on the Construction Management Plans. The off-site phasing will be complete prior to the Certificate of Occupancy of T1.



# 16 SCHEDULE:      wks

Total Parking: 87

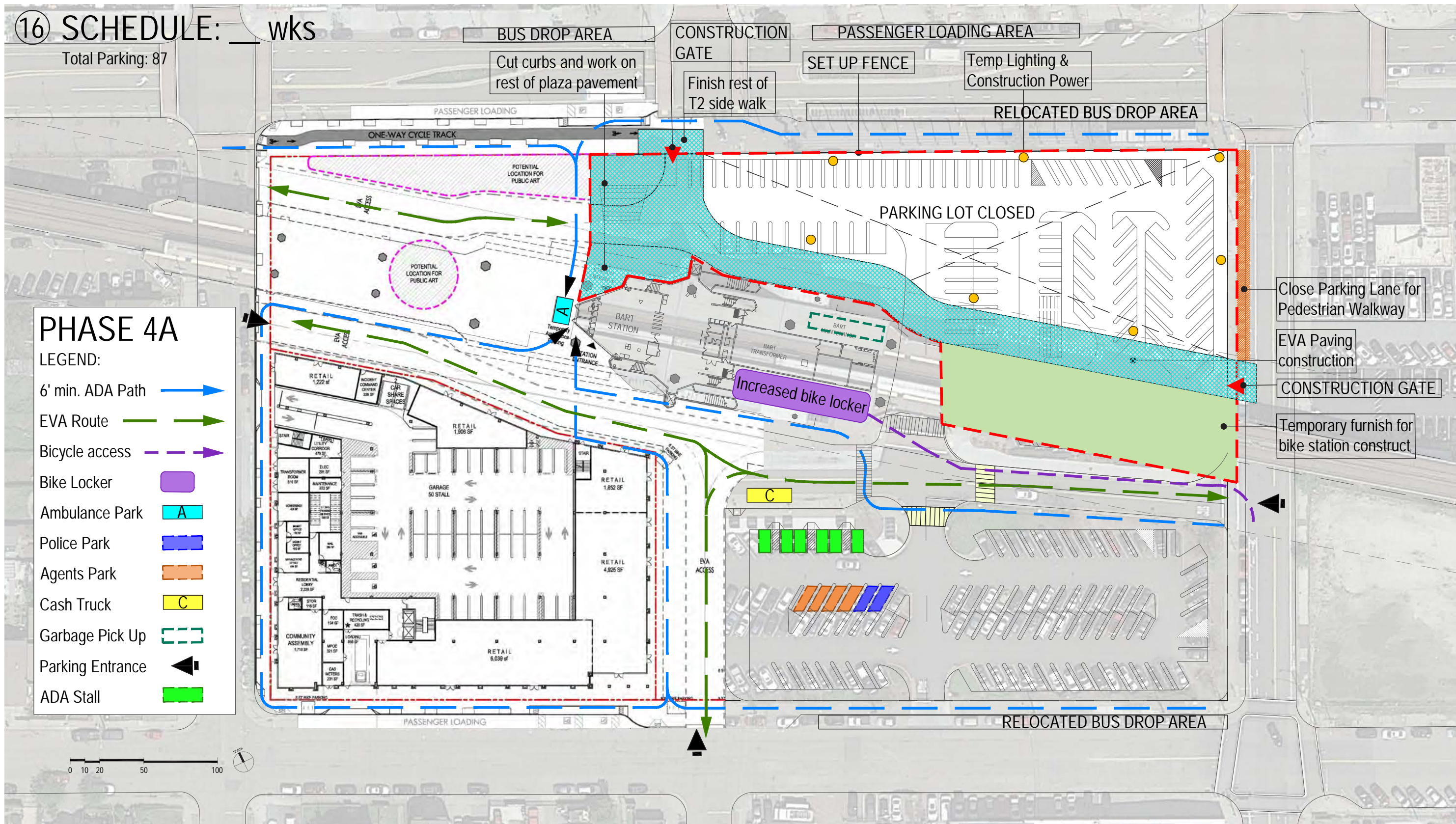

\*Refinements of the Phasing Plan will be incorporated into the project's CMP and that plan will include refinements to the site logistics plan, traffic control plan, and pedestrian and bike access plan, in order to minimize potential construction impacts and coordinate the various phases. Pursuant to COA #13, the CMP will be submitted to the City for review and approval by the Bureau of Planning, Bureau of Building, and other relevant City departments, including the Fire Department, Department of Transportation, and the Public Works Department.

\* The off-site phasing will be determined based on the Construction Management Plans. The off-site phasing will be complete prior to the Certificate of Occupancy of T1.

## PHASE 4A REORGANIZED ROUTES

# 17 SCHEDULE:      wks

Total Parking: 87

## PHASE 4B T1

### NOTES:

1. T2 plaza paving finished.
2. Set up fence and luffing crane.
3. Add one street lane into fence as staging area
4. Work on the bike station while finishing pavement.

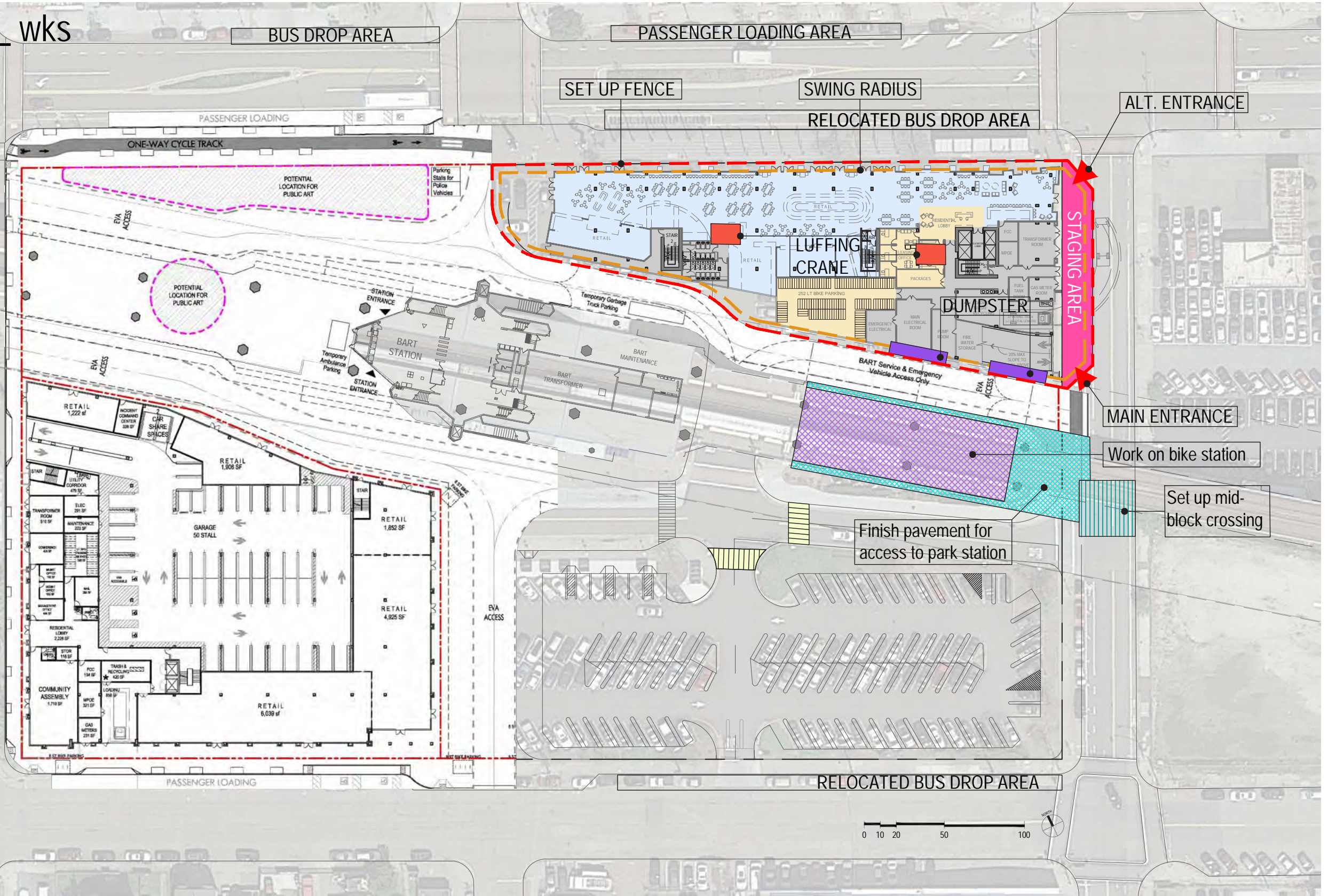

\*Refinements of the Phasing Plan will be incorporated into the project's CMP and that plan will include refinements to the site logistics plan, traffic control plan, and pedestrian and bike access plan, in order to minimize potential construction impacts and coordinate the various phases. Pursuant to COA #13, the CMP will be submitted to the City for review and approval by the Bureau of Planning, Bureau of Building, and other relevant City departments, including the Fire Department, Department of Transportation, and the Public Works Department.

\*The off-site phasing will be determined based on the Construction Management Plans. The off-site phasing will be complete prior to the Certificate of Occupancy of T1.

\*The phasing of the bike station will be determined based on funding and construction phasing of the surrounding parcels; and will be documented within the Construction Management Plans. The phasing will likely follow completion of T1 and/or the completion of the adjacent EVA access routes; but, will be based on availability of grants and/or other funding.

18 SCHEDULE:      wks

Total Parking: 87

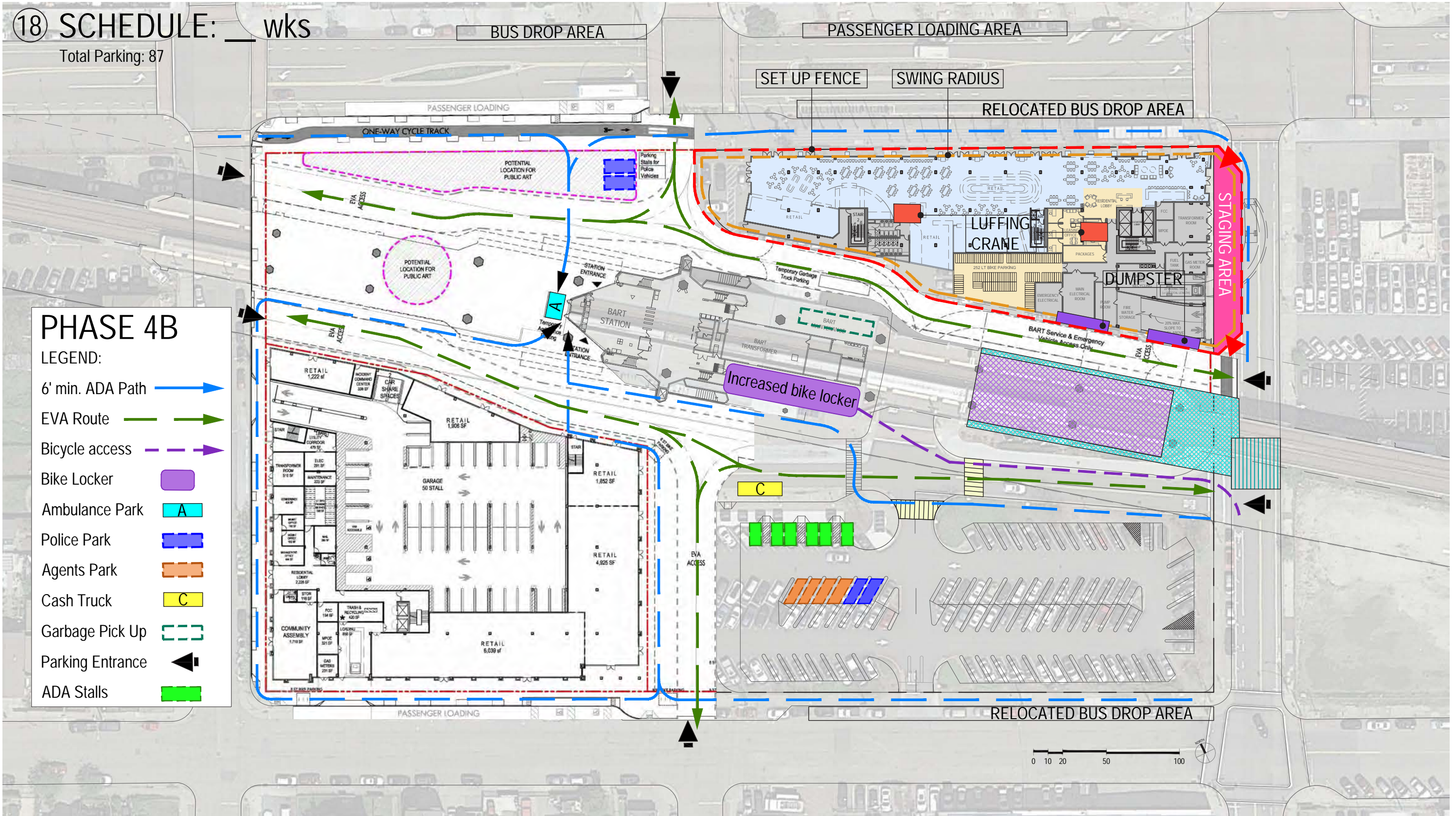

**PHASE 4B**

LEGEND:

- 6' min. ADA Path →
- EVA Route →
- Bicycle access →
- Bike Locker
- Ambulance Park  A
- Police Park
- Agents Park
- Cash Truck  C
- Garbage Pick Up
- Parking Entrance ▶
- ADA Stalls

\*Refinements of the Phasing Plan will be incorporated into the project's CMP and that plan will include refinements to the site logistics plan, traffic control plan, and pedestrian and bike access plan, in order to minimize potential construction impacts and coordinate the various phases. Pursuant to COA #13, the CMP will be submitted to the City for review and approval by the Bureau of Planning, Bureau of Building, and other relevant City departments, including the Fire Department, Department of Transportation, and the Public Works Department.

\*The off-site phasing will be determined based on the Construction Management Plans. The off-site phasing will be complete prior to the Certificate of Occupancy of T1.

\*The phasing of the bike station will be determined based on funding and construction phasing of the surrounding parcels; and will be documented within the Construction Management Plans. The phasing will likely follow completion of T1 and/or the completion of the adjacent EVA access routes; but, will be based on availability of grants and/or other funding.

**PHASE 4B  
REORGANIZED ROUTES**

19 SCHEDULE:      wks

Total Parking: 87

PHASE 4C T1

NOTES:

1. T1 building construction done.
2. Finish pavement of T1 side walks and under track area.

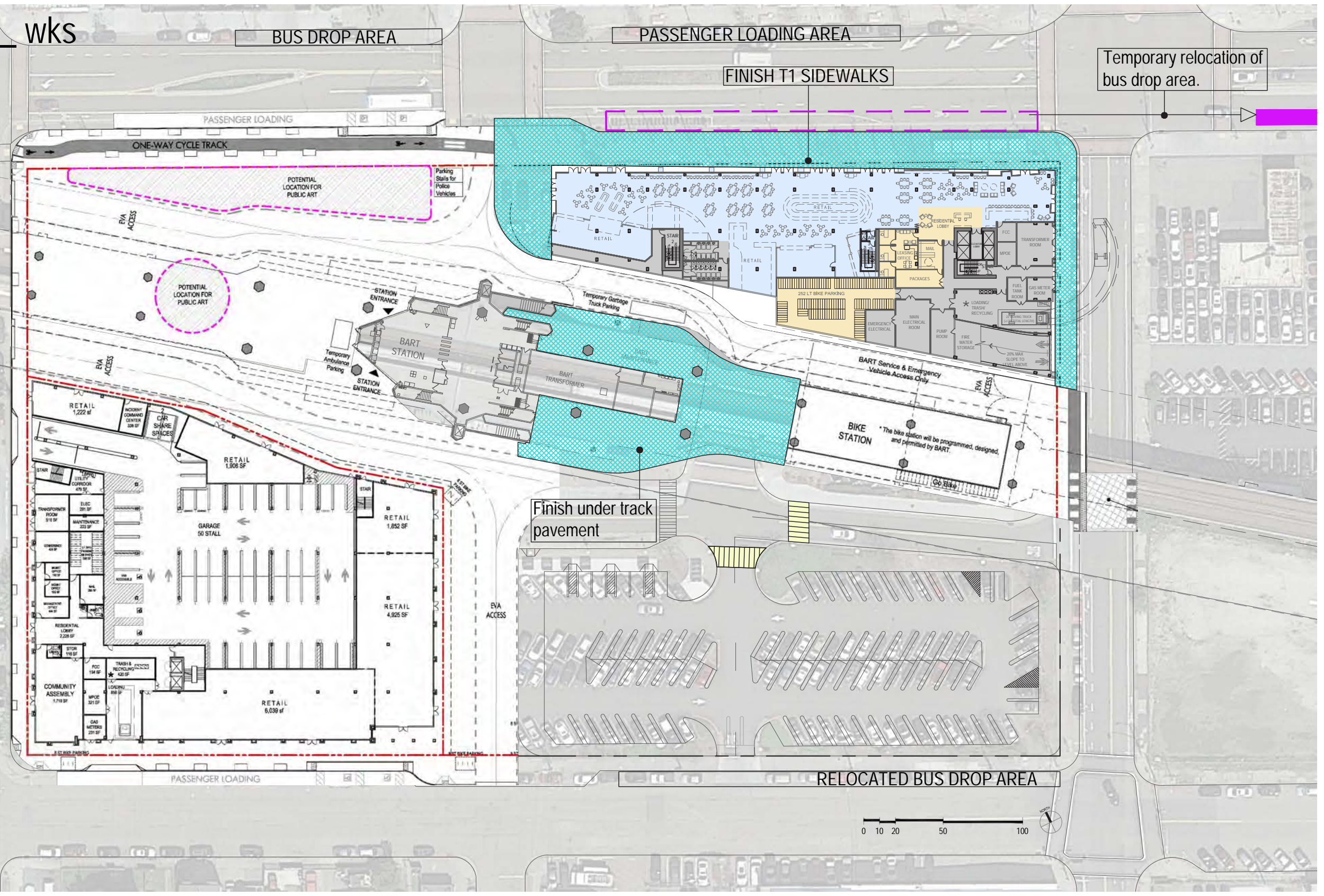

\*Refinements of the Phasing Plan will be incorporated into the project's CMP and that plan will include refinements to the site logistics plan, traffic control plan, and pedestrian and bike access plan, in order to minimize potential construction impacts and coordinate the various phases. Pursuant to COA #13, the CMP will be submitted to the City for review and approval by the Bureau of Planning, Bureau of Building, and other relevant City departments, including the Fire Department, Department of Transportation, and the Public Works Department.

\* The off-site phasing will be determined based on the Construction Management Plans. The off-site phasing will be complete prior to the Certificate of Occupancy of T1.

20 SCHEDULE:      wks

Total Parking: 87

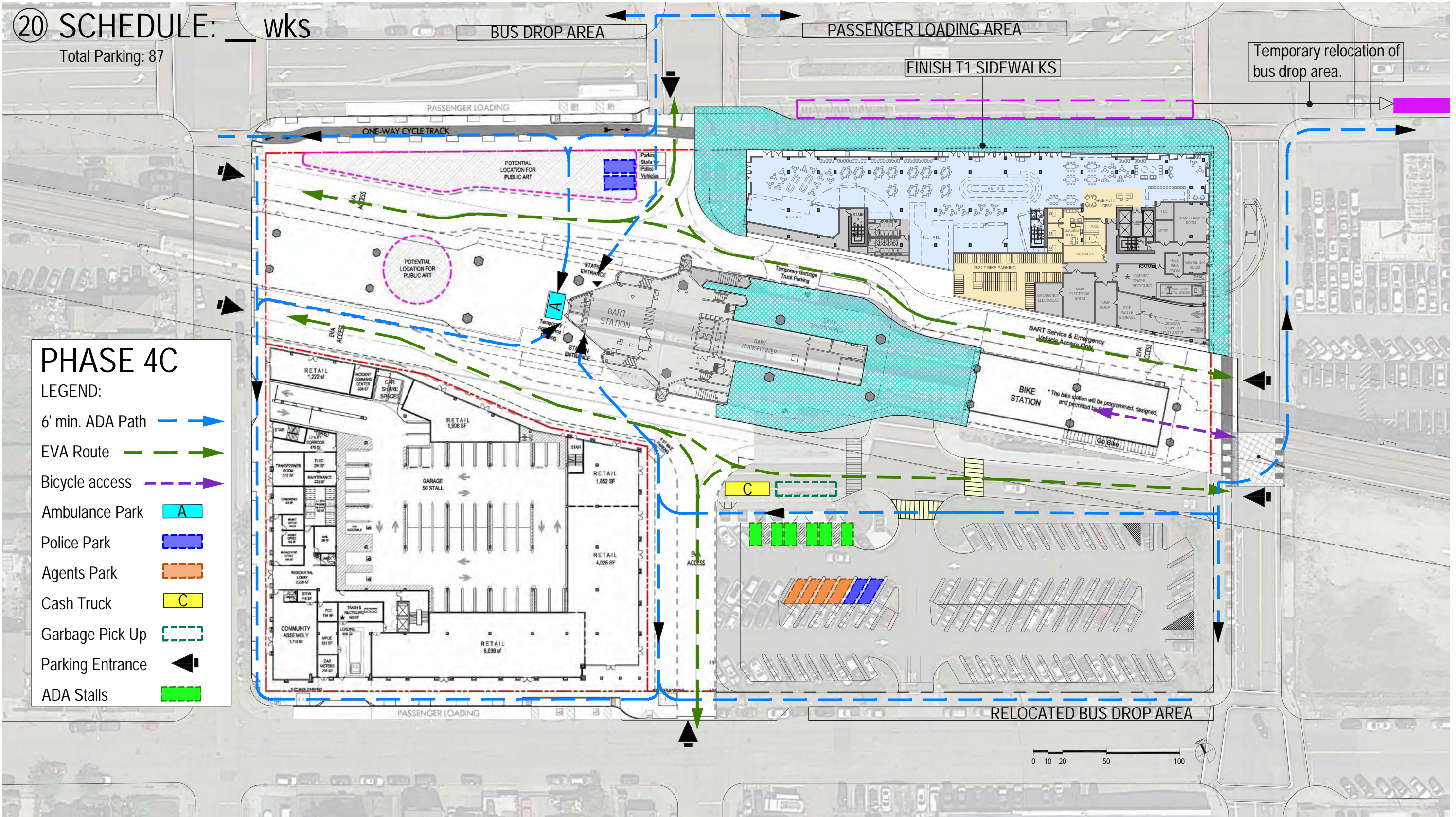

**PHASE 4C**

LEGEND:

- 6' min. ADA Path →
- EVA Route →
- Bicycle access →
- Ambulance Park A
- Police Park B
- Agents Park C
- Cash Truck D
- Garbage Pick Up E
- Parking Entrance ▶
- ADA Stalls F

\*Refinements of the Phasing Plan will be incorporated into the project's CMP and that plan will include refinements to the site logistics plan, traffic control plan, and pedestrian and bike access plan, in order to minimize potential construction impacts and coordinate the various phases. Pursuant to COA #13, the CMP will be submitted to the City for review and approval by the Bureau of Planning, Bureau of Building, and other relevant City departments, including the Fire Department, Department of Transportation, and the Public Works Department.

\* The off-site phasing will be determined based on the Construction Management Plans. The off-site phasing will be complete prior to the Certificate of Occupancy of T1.

21 SCHEDULE:      wks

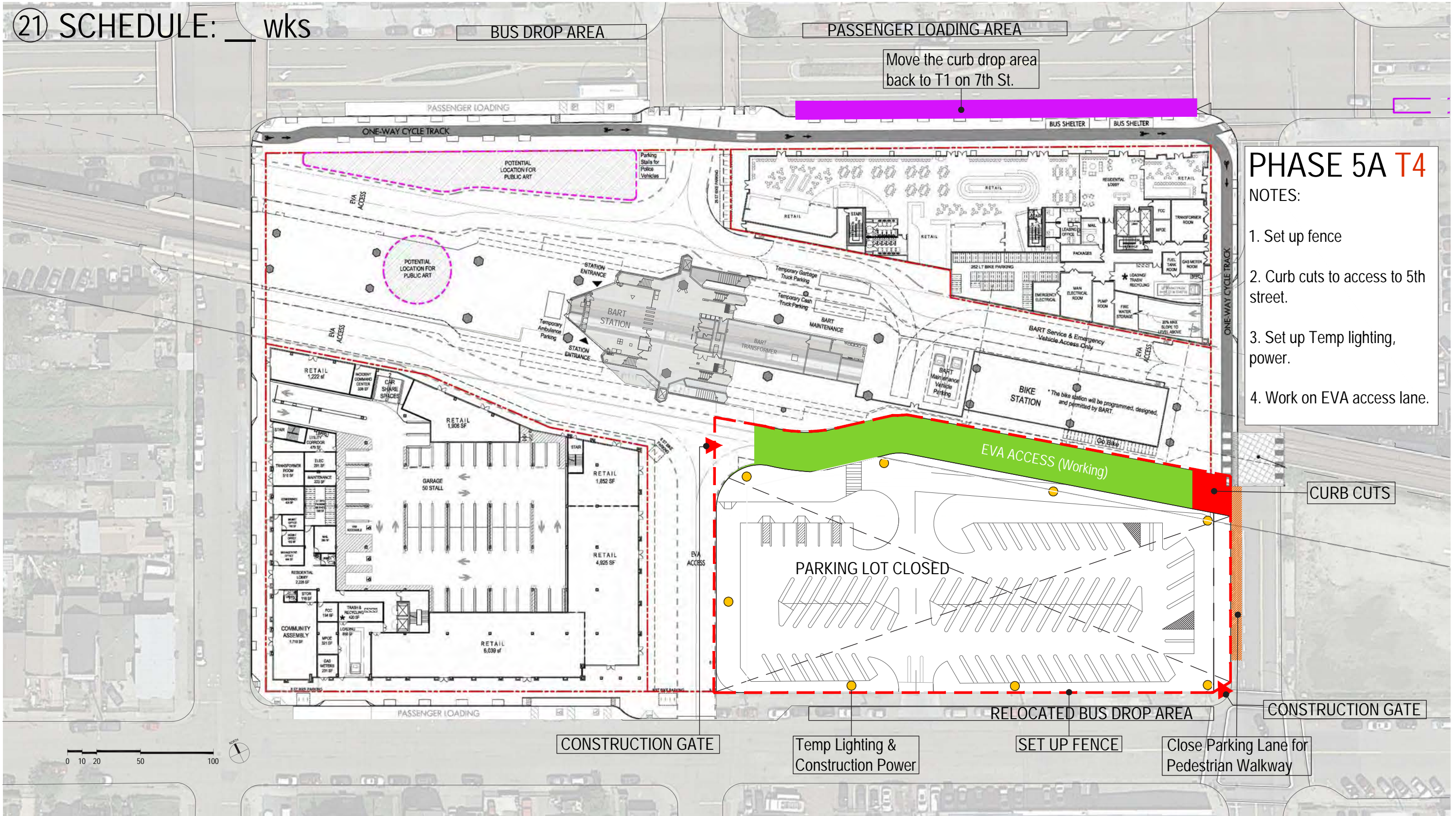

**PHASE 5A T4**

- NOTES:
1. Set up fence
  2. Curb cuts to access to 5th street.
  3. Set up Temp lighting, power.
  4. Work on EVA access lane.

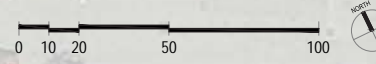

\*Refinements of the Phasing Plan will be incorporated into the project's CMP and that plan will include refinements to the site logistics plan, traffic control plan, and pedestrian and bike access plan, in order to minimize potential construction impacts and coordinate the various phases. Pursuant to COA #13, the CMP will be submitted to the City for review and approval by the Bureau of Planning, Bureau of Building, and other relevant City departments, including the Fire Department, Department of Transportation, and the Public Works Department.

\* The off-site phasing will be determined based on the Construction Management Plans. The off-site phasing will be complete prior to the Certificate of Occupancy of T1.

22 SCHEDULE:      wks

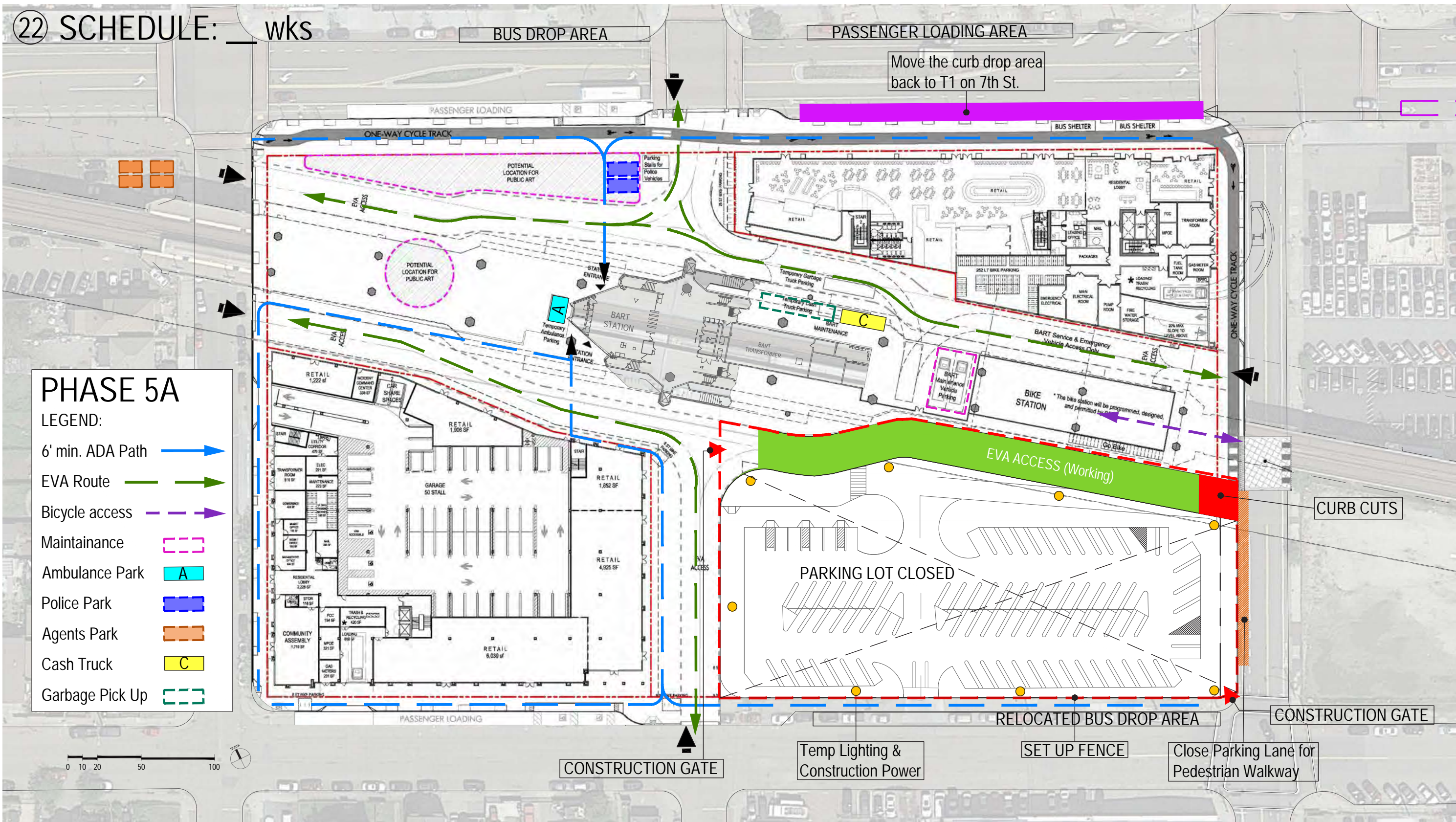

\*Refinements of the Phasing Plan will be incorporated into the project's CMP and that plan will include refinements to the site logistics plan, traffic control plan, and pedestrian and bike access plan, in order to minimize potential construction impacts and coordinate the various phases. Pursuant to COA #13, the CMP will be submitted to the City for review and approval by the Bureau of Planning, Bureau of Building, and other relevant City departments, including the Fire Department, Department of Transportation, and the Public Works Department.

\* The off-site phasing will be determined based on the Construction Management Plans. The off-site phasing will be complete prior to the Certificate of Occupancy of T1.

23 SCHEDULE:      wks

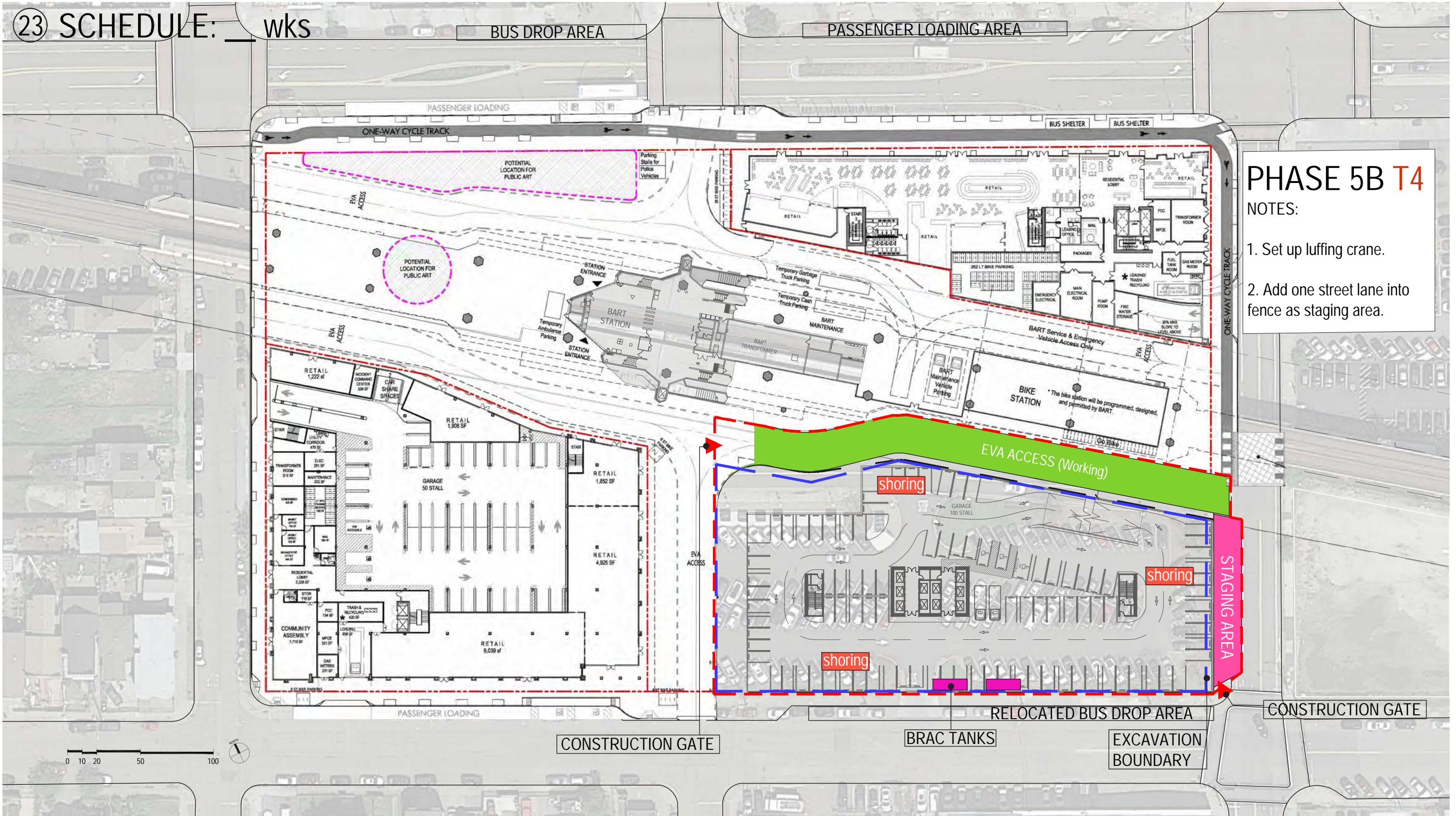

**PHASE 5B T4**

- NOTES:
1. Set up luffing crane.
  2. Add one street lane into fence as staging area.

\*Refinements of the Phasing Plan will be incorporated into the project's CMP and that plan will include refinements to the site logistics plan, traffic control plan, and pedestrian and bike access plan, in order to minimize potential construction impacts and coordinate the various phases. Pursuant to COA #13, the CMP will be submitted to the City for review and approval by the Bureau of Planning, Bureau of Building, and other relevant City departments, including the Fire Department, Department of Transportation, and the Public Works Department.

\* The off-site phasing will be determined based on the Construction Management Plans. The off-site phasing will be complete prior to the Certificate of Occupancy of T1.



24 SCHEDULE: wks

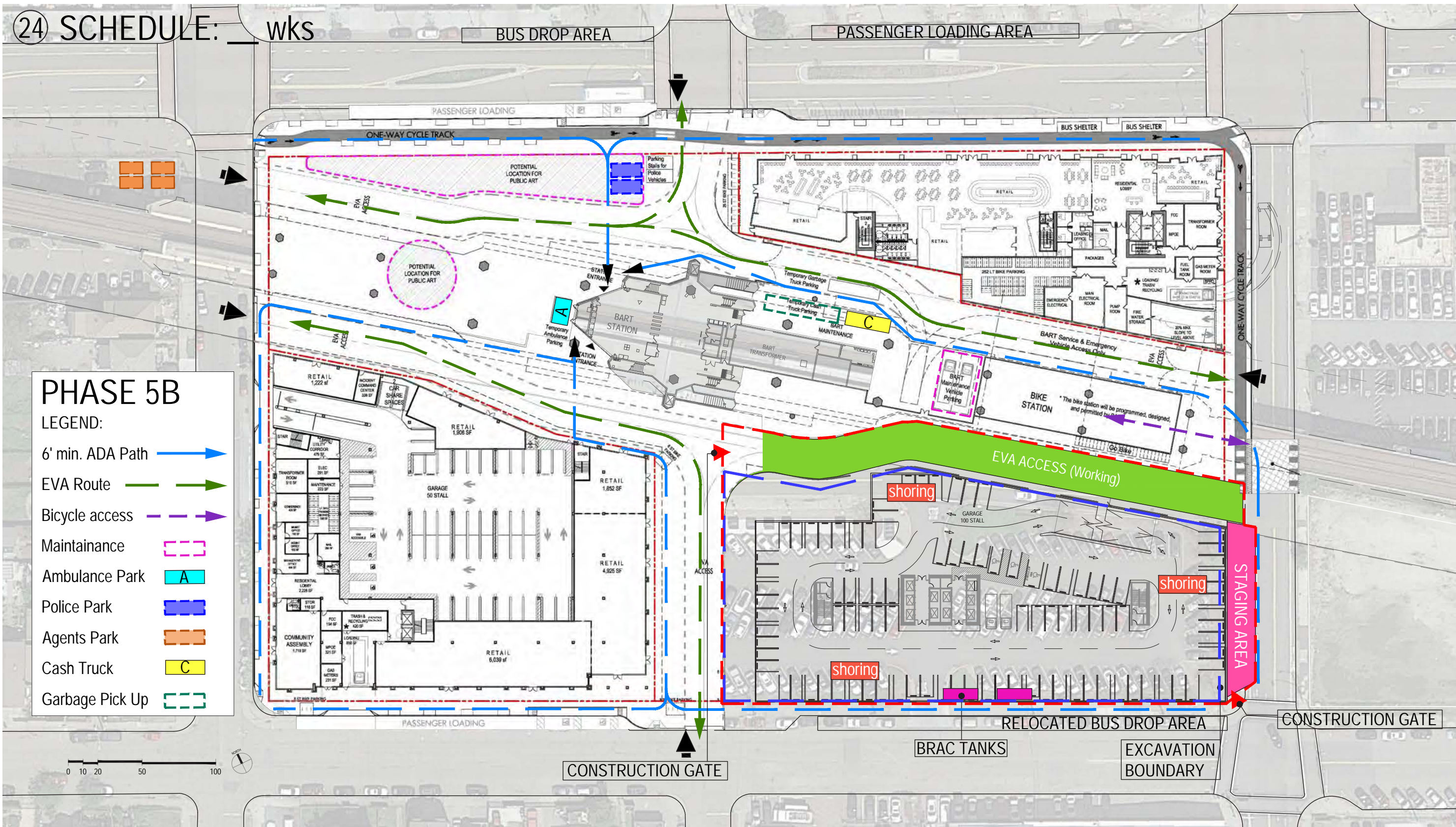

**PHASE 5B**  
**LEGEND:**

- 6' min. ADA Path →
- EVA Route →
- Bicycle access →
- Maintainance
- Ambulance Park A
- Police Park B
- Agents Park
- Cash Truck C
- Garbage Pick Up

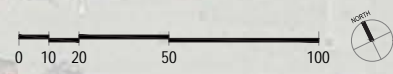

\*Refinements of the Phasing Plan will be incorporated into the project's CMP and that plan will include refinements to the site logistics plan, traffic control plan, and pedestrian and bike access plan, in order to minimize potential construction impacts and coordinate the various phases. Pursuant to COA #13, the CMP will be submitted to the City for review and approval by the Bureau of Planning, Bureau of Building, and other relevant City departments, including the Fire Department, Department of Transportation, and the Public Works Department.

\* The off-site phasing will be determined based on the Construction Management Plans. The off-site phasing will be complete prior to the Certificate of Occupancy of T1.

25 SCHEDULE:      wks

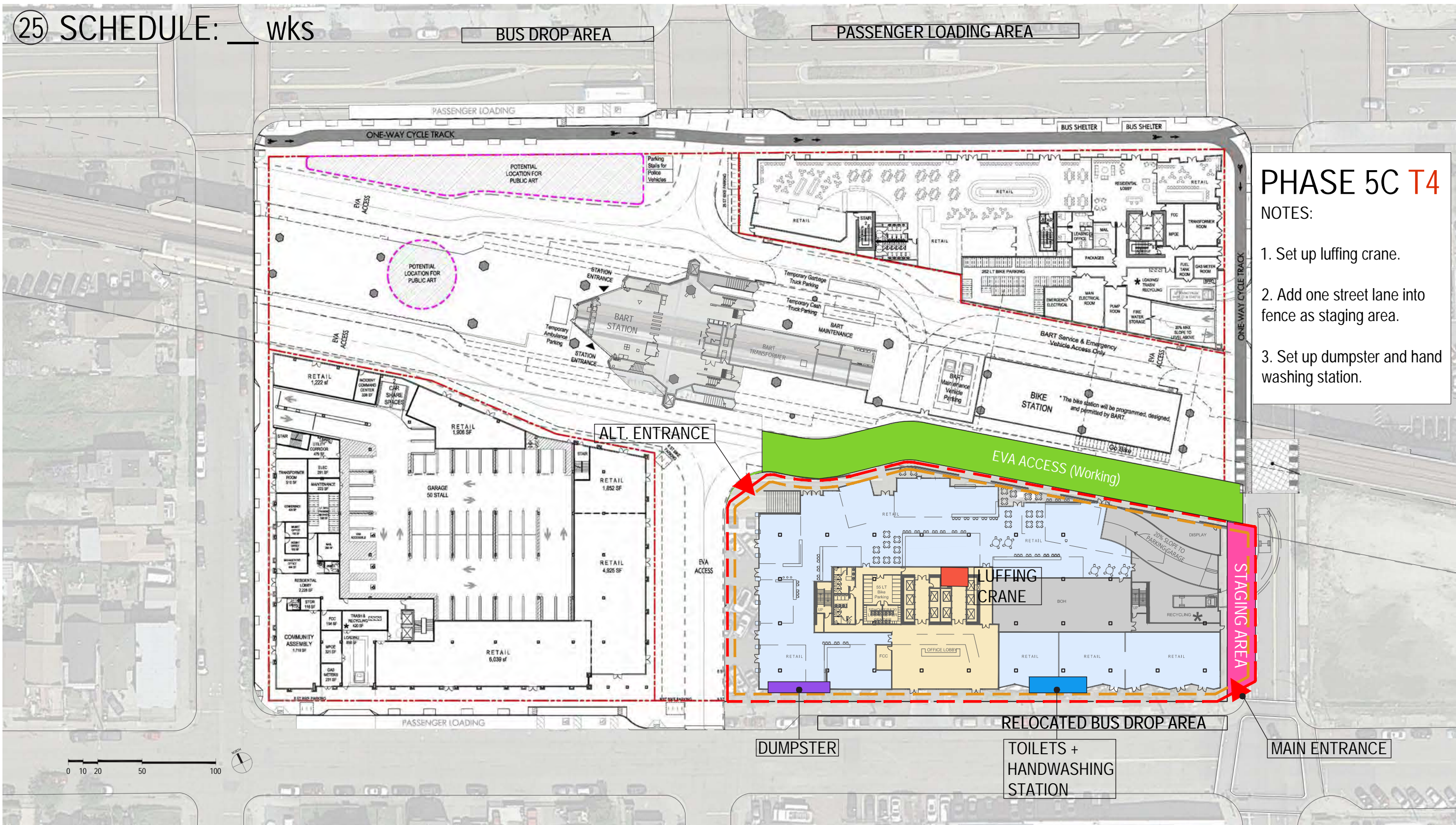

## PHASE 5C T4

NOTES:

1. Set up luffing crane.
2. Add one street lane into fence as staging area.
3. Set up dumpster and hand washing station.

\*Refinements of the Phasing Plan will be incorporated into the project's CMP and that plan will include refinements to the site logistics plan, traffic control plan, and pedestrian and bike access plan, in order to minimize potential construction impacts and coordinate the various phases. Pursuant to COA #13, the CMP will be submitted to the City for review and approval by the Bureau of Planning, Bureau of Building, and other relevant City departments, including the Fire Department, Department of Transportation, and the Public Works Department.

\* The off-site phasing will be determined based on the Construction Management Plans. The off-site phasing will be complete prior to the Certificate of Occupancy of T1.

PHASE 5C FINISH  
T4 PAVING OF SIDE WALK

26 SCHEDULE: WKS

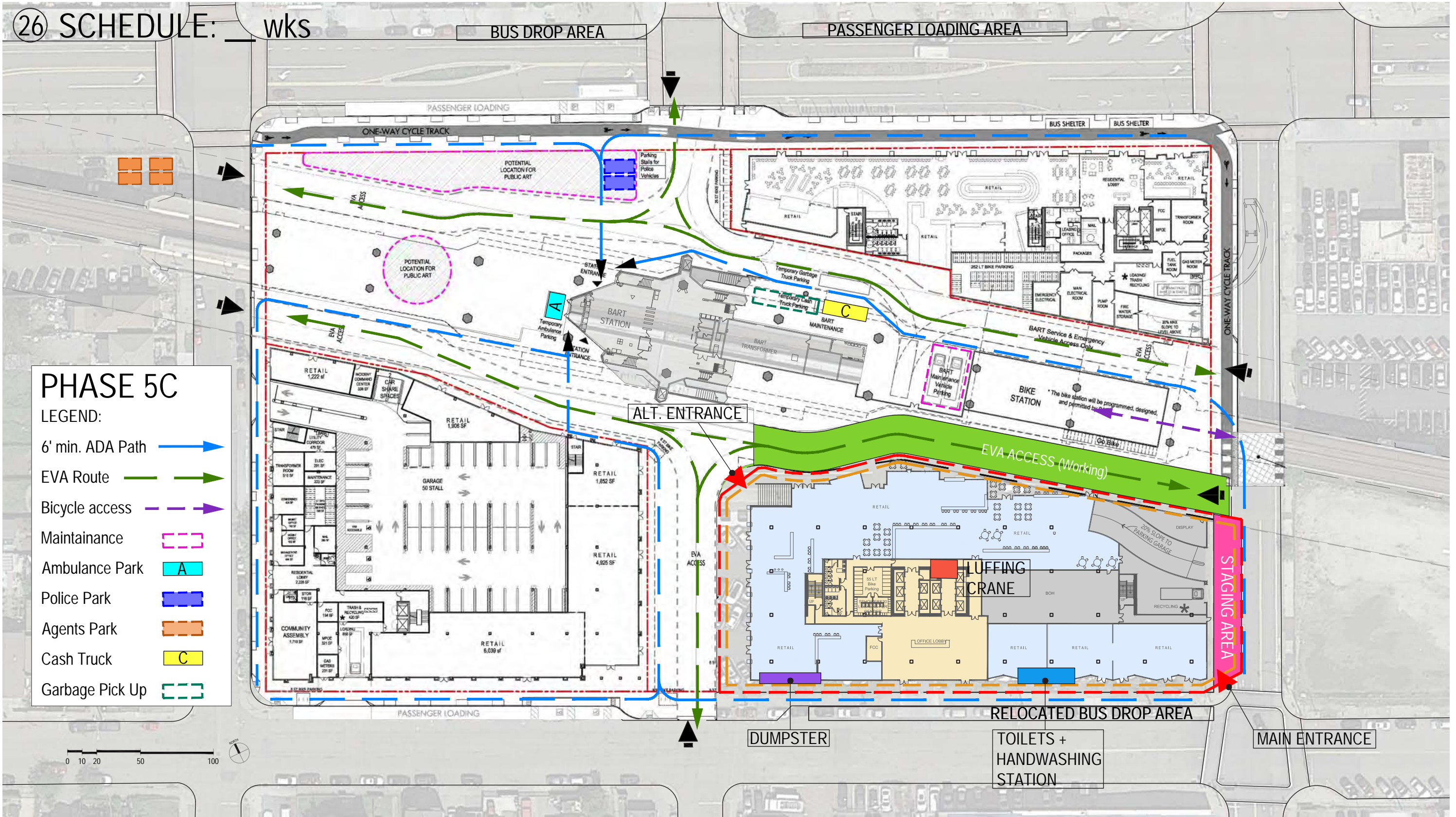

\*Refinements of the Phasing Plan will be incorporated into the project's CMP and that plan will include refinements to the site logistics plan, traffic control plan, and pedestrian and bike access plan, in order to minimize potential construction impacts and coordinate the various phases. Pursuant to COA #13, the CMP will be submitted to the City for review and approval by the Bureau of Planning, Bureau of Building, and other relevant City departments, including the Fire Department, Department of Transportation, and the Public Works Department.

\* The off-site phasing will be determined based on the Construction Management Plans. The off-site phasing will be complete prior to the Certificate of Occupancy of T1.

27 SCHEDULE: WKS

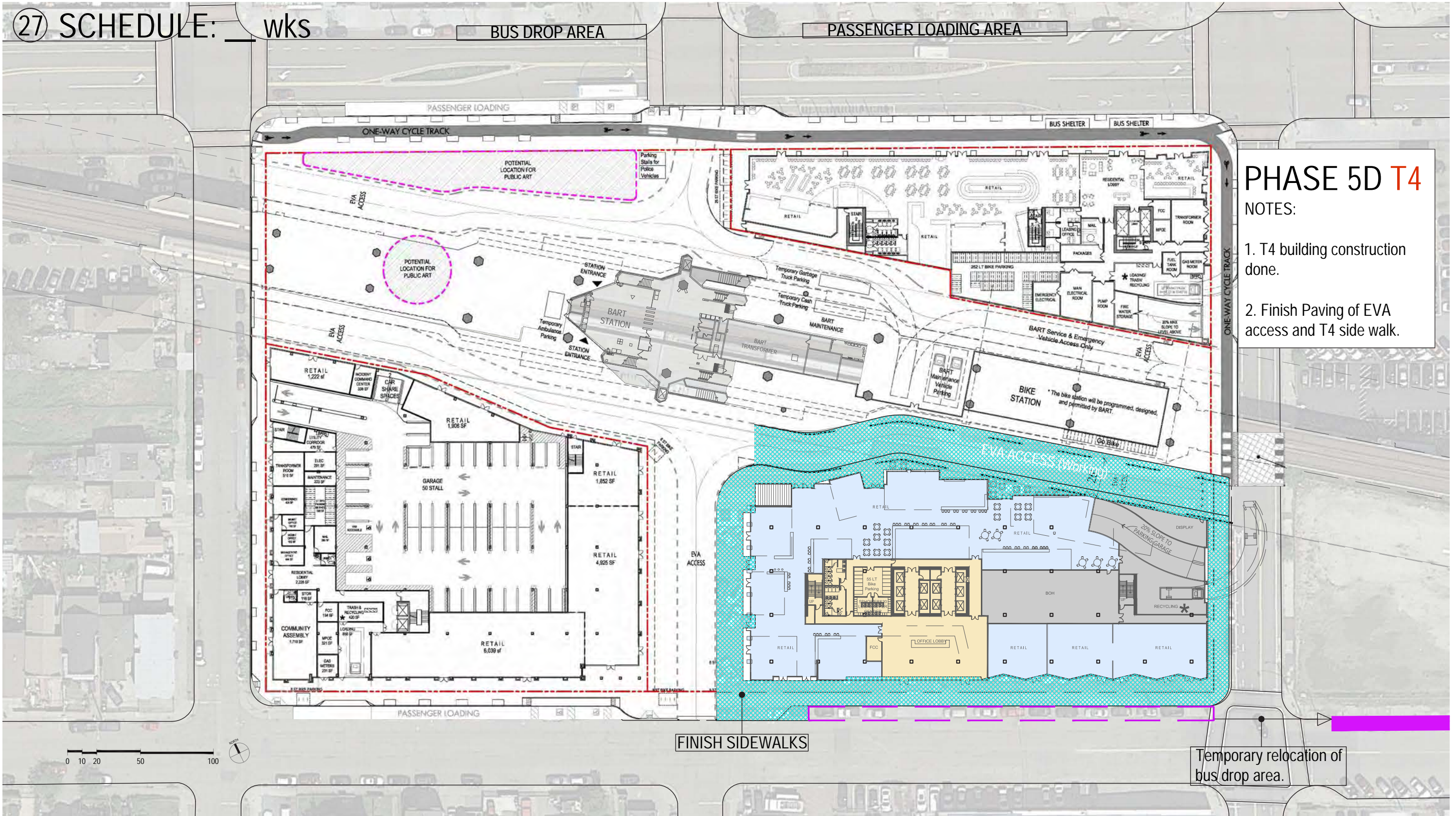

PHASE 5D T4

- NOTES:
1. T4 building construction done.
  2. Finish Paving of EVA access and T4 side walk.

Temporary relocation of bus drop area.

\*Refinements of the Phasing Plan will be incorporated into the project's CMP and that plan will include refinements to the site logistics plan, traffic control plan, and pedestrian and bike access plan, in order to minimize potential construction impacts and coordinate the various phases. Pursuant to COA #13, the CMP will be submitted to the City for review and approval by the Bureau of Planning, Bureau of Building, and other relevant City departments, including the Fire Department, Department of Transportation, and the Public Works Department.

\* The off-site phasing will be determined based on the Construction Management Plans. The off-site phasing will be complete prior to the Certificate of Occupancy of T1.

PHASE 5D FINISH T4 PAVING OF SIDE WALK

28 SCHEDULE:      wks

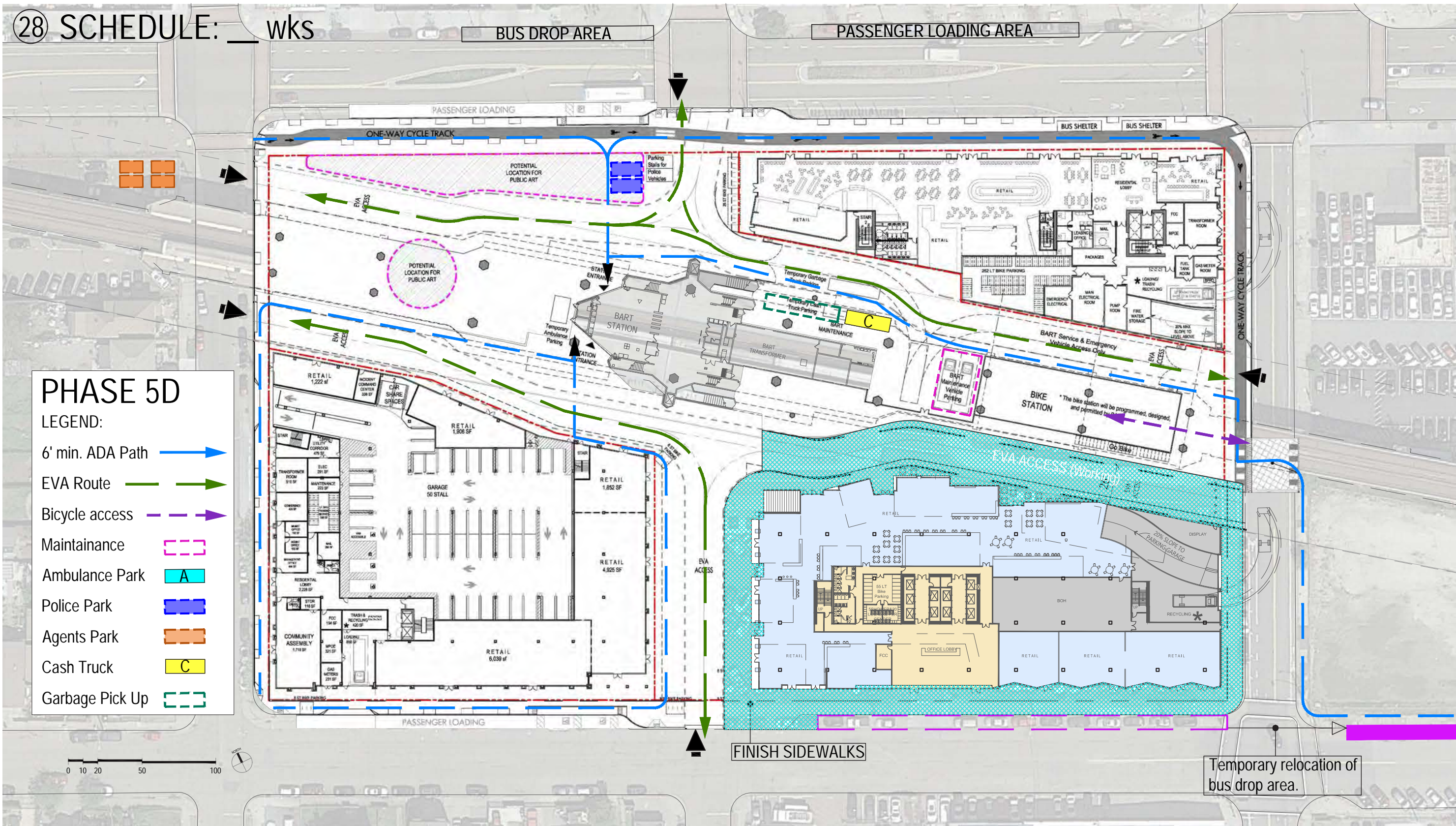

PHASE 5D

LEGEND:

- 6' min. ADA Path →
- EVA Route →
- Bicycle access →
- Maintainance
- Ambulance Park A
- Police Park B
- Agents Park C
- Cash Truck C
- Garbage Pick Up

\*Refinements of the Phasing Plan will be incorporated into the project's CMP and that plan will include refinements to the site logistics plan, traffic control plan, and pedestrian and bike access plan, in order to minimize potential construction impacts and coordinate the various phases. Pursuant to COA #13, the CMP will be submitted to the City for review and approval by the Bureau of Planning, Bureau of Building, and other relevant City departments, including the Fire Department, Department of Transportation, and the Public Works Department.

\* The off-site phasing will be determined based on the Construction Management Plans. The off-site phasing will be complete prior to the Certificate of Occupancy of T1.

29 SCHEDULE:      wks

BUS DROP AREA

PASSENGER LOADING AREA

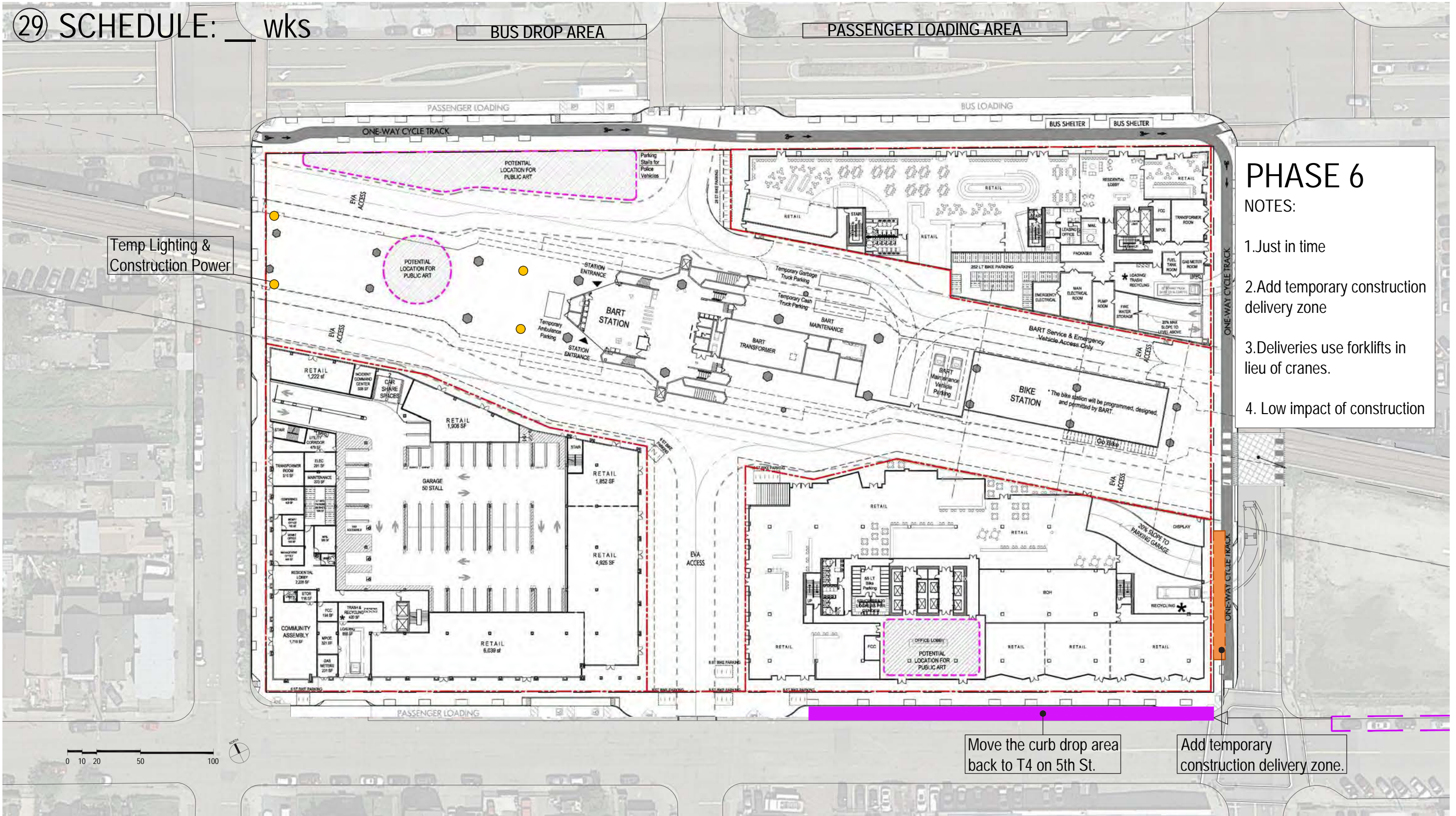

## PHASE 6

NOTES:

1. Just in time
2. Add temporary construction delivery zone
3. Deliveries use forklifts in lieu of cranes.
4. Low impact of construction

Temp Lighting & Construction Power

Move the curb drop area back to T4 on 5th St.

Add temporary construction delivery zone.

\*Refinements of the Phasing Plan will be incorporated into the project's CMP and that plan will include refinements to the site logistics plan, traffic control plan, and pedestrian and bike access plan, in order to minimize potential construction impacts and coordinate the various phases. Pursuant to COA #13, the CMP will be submitted to the City for review and approval by the Bureau of Planning, Bureau of Building, and other relevant City departments, including the Fire Department, Department of Transportation, and the Public Works Department.

\* The off-site phasing will be determined based on the Construction Management Plans. The off-site phasing will be complete prior to the Certificate of Occupancy of T1.

PHASE 6 UNDER TRACK  
RETAIL CONSTRUCTION

30 SCHEDULE:      wks

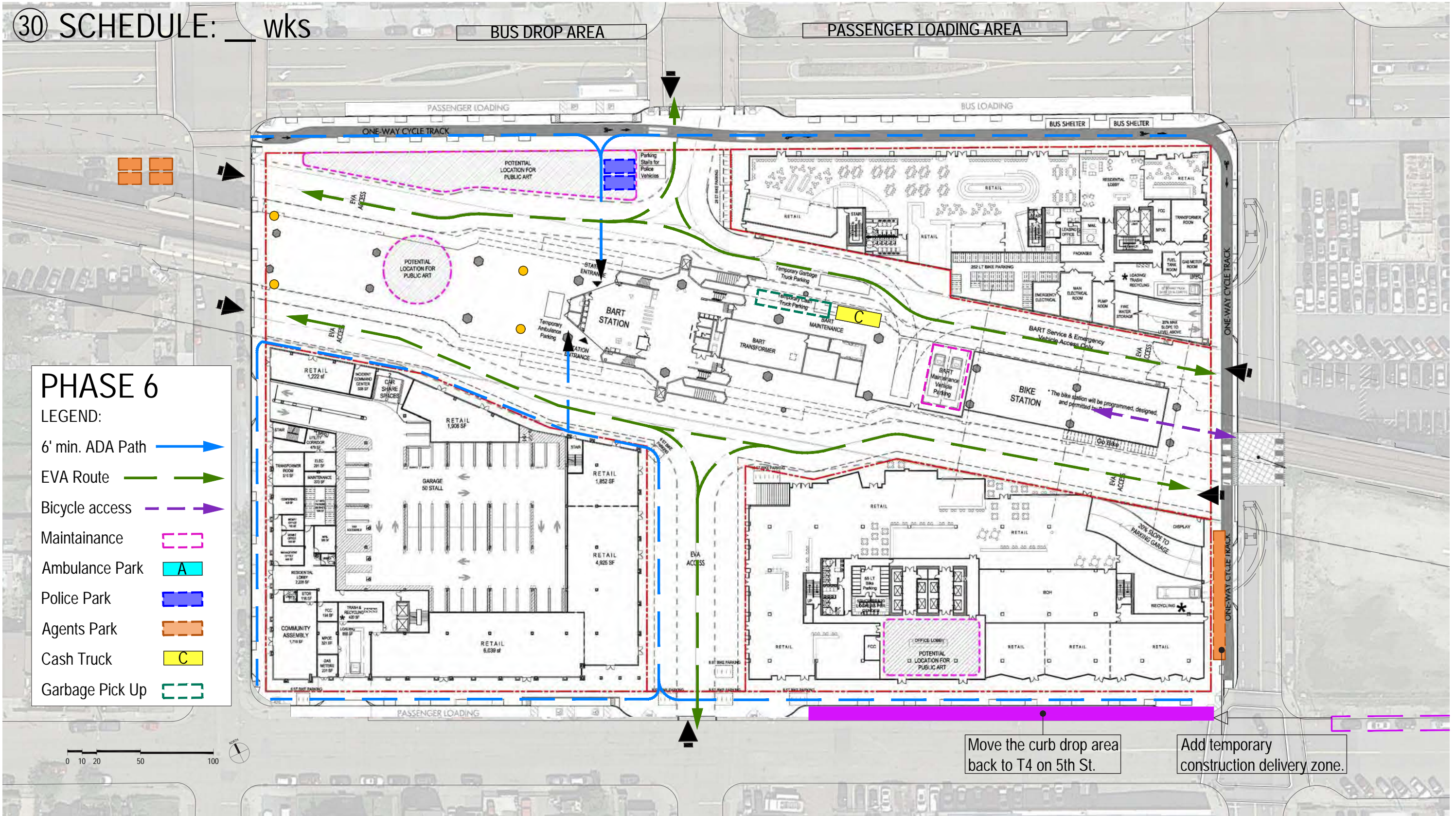

**PHASE 6**

LEGEND:

- 6' min. ADA Path →
- EVA Route →
- Bicycle access →
- Maintainance
- Ambulance Park A
- Police Park B
- Agents Park
- Cash Truck C
- Garbage Pick Up

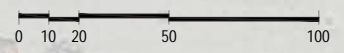

\*Refinements of the Phasing Plan will be incorporated into the project's CMP and that plan will include refinements to the site logistics plan, traffic control plan, and pedestrian and bike access plan, in order to minimize potential construction impacts and coordinate the various phases. Pursuant to COA #13, the CMP will be submitted to the City for review and approval by the Bureau of Planning, Bureau of Building, and other relevant City departments, including the Fire Department, Department of Transportation, and the Public Works Department.

\* The off-site phasing will be determined based on the Construction Management Plans. The off-site phasing will be complete prior to the Certificate of Occupancy of T1.

31 SCHEDULE:      wks

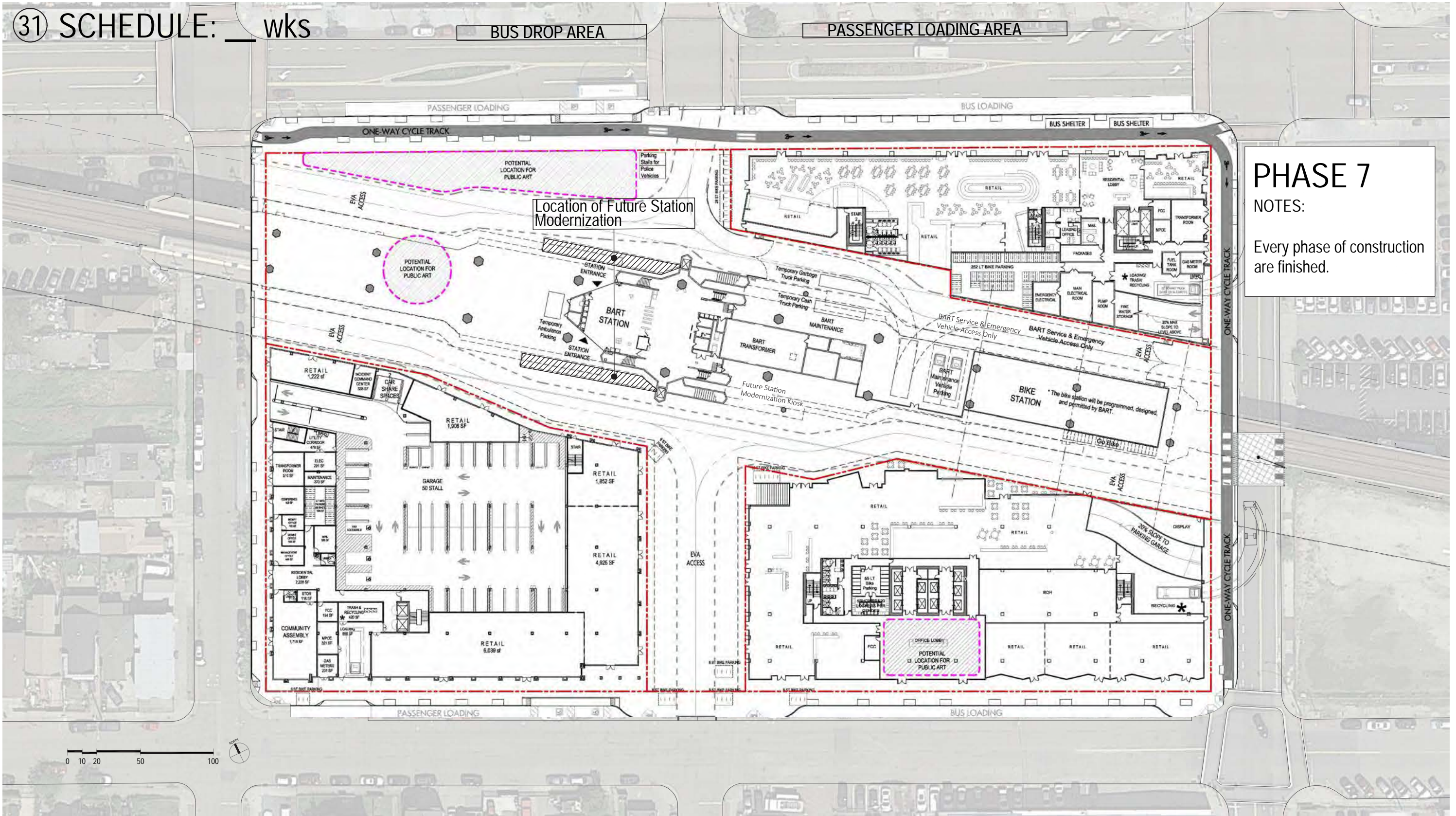

**PHASE 7**  
 NOTES:  
 Every phase of construction are finished.

\*Refinements of the Phasing Plan will be incorporated into the project's CMP and that plan will include refinements to the site logistics plan, traffic control plan, and pedestrian and bike access plan, in order to minimize potential construction impacts and coordinate the various phases. Pursuant to COA #13, the CMP will be submitted to the City for review and approval by the Bureau of Planning, Bureau of Building, and other relevant City departments, including the Fire Department, Department of Transportation, and the Public Works Department.

\* The off-site phasing will be determined based on the Construction Management Plans. The off-site phasing will be complete prior to the Certificate of Occupancy of T1.

**PHASE 7 EVERY  
 CONSTRUCTION PHASE DONE**



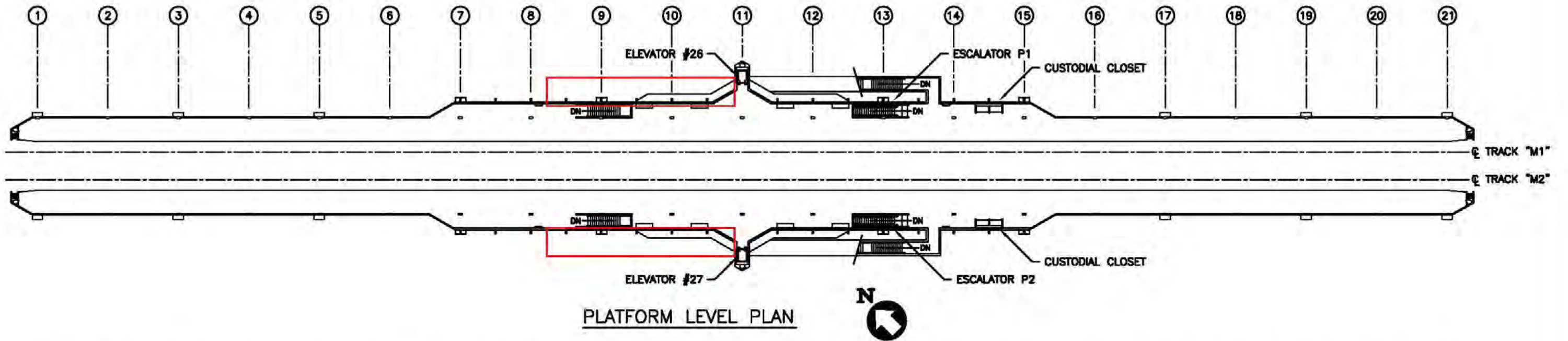

PLATFORM LEVEL PLAN

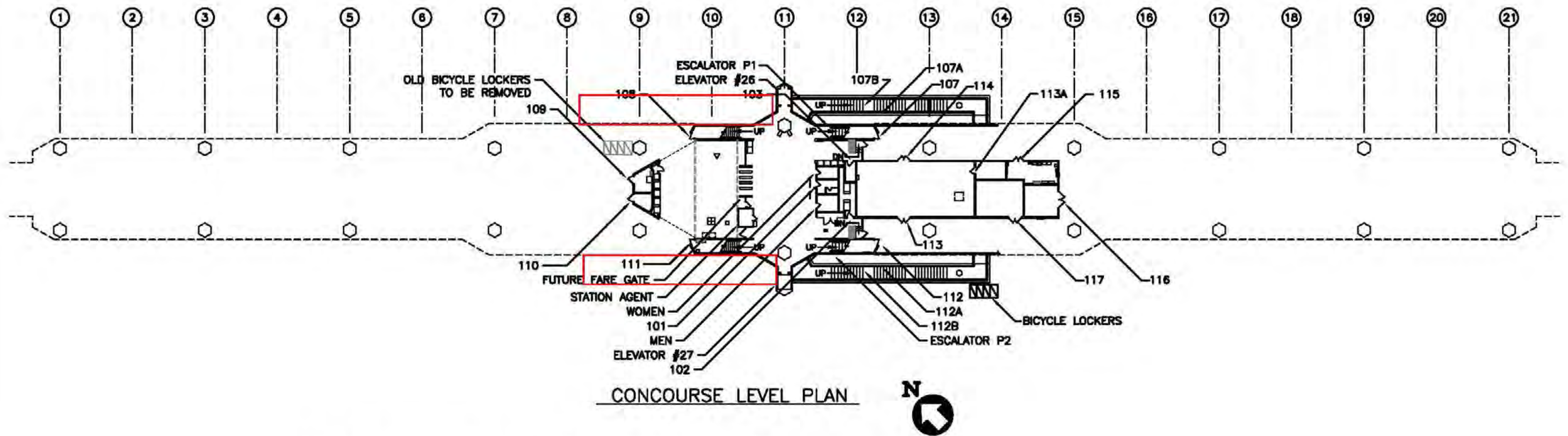

CONCOURSE LEVEL PLAN

DOOR/ROOM LEGEND					
DR.NO.	USE	DR.NO.	USE	DR.NO.	USE
101	STAFF RESTROOM	109	CUSTODIAN	113A	BATTERY RM.
102	ELEV. EQUIP. RM.	110	STAFF BREAKROOM	114	TRAIN CONTROL
103	STORAGE	111	ELECT. EQUIP.	115	ELECT. EQUIP.
107	STORAGE	112	STORAGE	116	TRANSFORMER
107A	GATE	112A	GATE	117	FAN ROOM
107B	STORAGE	112B	STORAGE		
108	STORAGE	113	TRAIN CONTROL		

**WEST OAKLAND STATION - OWS**  
**"M" LINE - STATION M-10**  
**FLOOR PLANS**

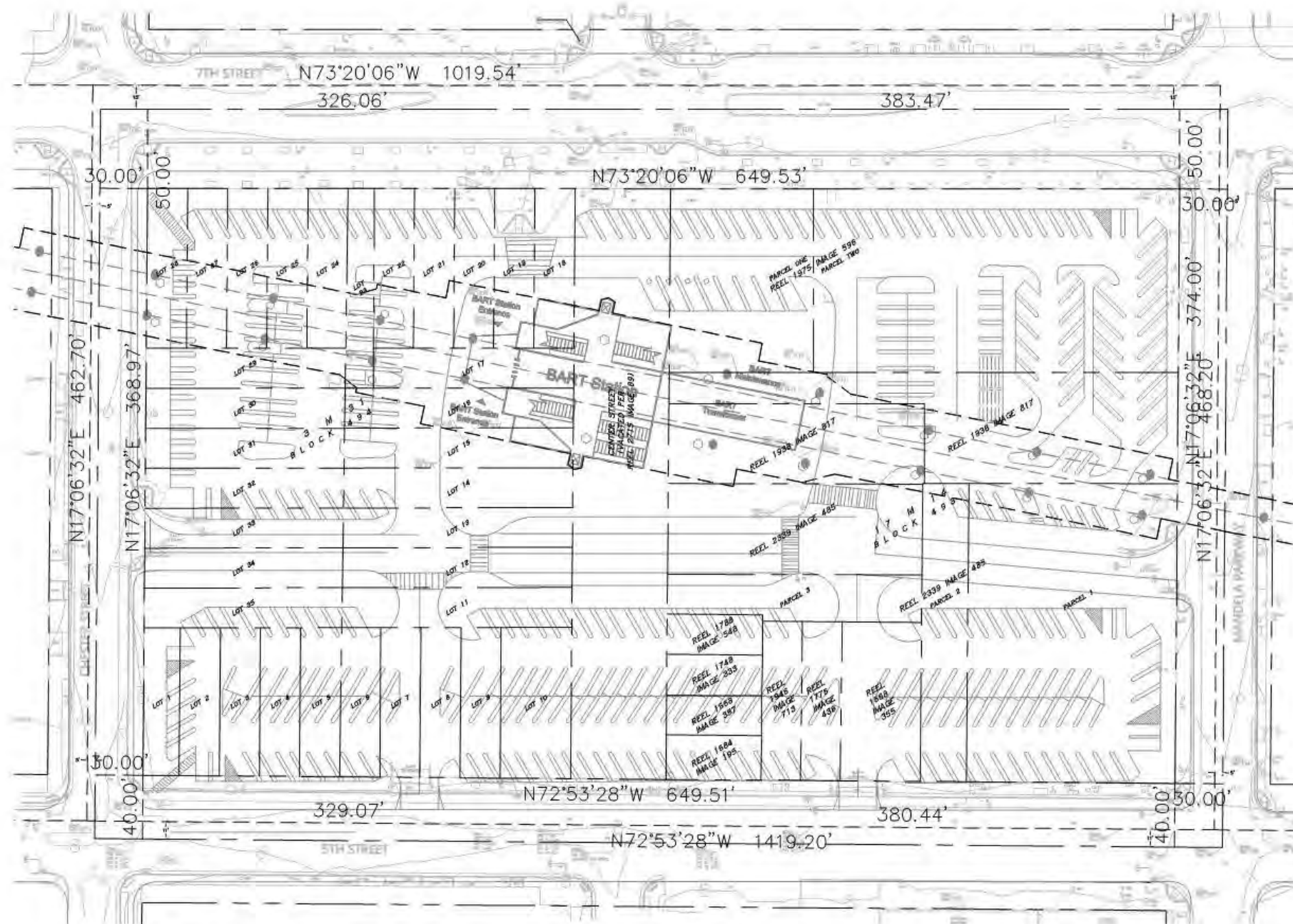

**NOTE:**  
 EXISTING BOUNDARY FROM RECORD INFORMATION FOR  
 PLANNING PURPOSES ONLY

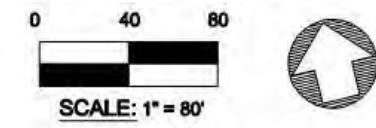

Revisions	
No.	Description

Date:	12/06/2018
Scale:	AS SHOWN
Design:	N/A
Drawn:	ADD
Approved:	KS
Job No:	180384

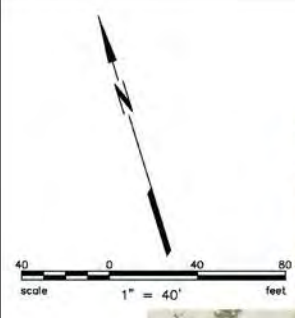

**BASIS OF BEARINGS**

THE BEARING OF NORTH 72°53'28" WEST BETWEEN FOUND MONUMENTS ON 5TH AVENUE BETWEEN HENRY STREET AND KIRKHAM STREET AS SHOWN ON THAT RECORD OF SURVEY, R/S 1687, FILED AUGUST 7, 2000 IN BOOK 25 OF RECORDS OF SURVEY AT PAGES 58-69, INCLUSIVE, ALAMEDA COUNTY RECORDS, WAS TAKEN AS THE BASIS OF BEARINGS FOR THIS SURVEY.

**BENCHMARK**

THE ELEVATIONS SHOWN HEREON ARE BASED ON A FOUND CITY OF OAKLAND BENCHMARK, DESIGNATION 25/H, BEING A BRONZE DISK STAMPED, "SEC 25 STA H," ELEVATION 10.784 FEET (DATUM = MEAN SEA LEVEL).

**NOTES**

1. THE SURVEY WAS CONDUCTED IN NOVEMBER OF 2018.
2. ALL UNITS ARE IN US SURVEY FEET AND DECIMALS THEREOF.
3. THE TOPOGRAPHIC MAPPING SHOWN HEREON IS A WORKING DOCUMENT. THE TOPOGRAPHIC SURVEY AND MAPPING IS IN PROGRESS AND HAS NOT BEEN COMPLETED OR FINALIZED.

**SURVEYOR'S STATEMENT:**

THIS MAP CORRECTLY REPRESENTS A SURVEY MADE BY ME OR UNDER MY DIRECTION IN CONFORMANCE WITH THE REQUIREMENTS OF THE PROFESSIONAL LAND SURVEYOR'S ACT.

KEVIN STEIN, P.L.S. NO. 9028

DATE: 12/06/2018

**PRELIMINARY**

PROGRESS PRINT

DATE: 12/06/2018

GRAPHIC SCALE: 1" = 40' FEET. DATE: 12/06/2018. DRAWN BY: ADD. APPROVED BY: KS. JOB NO: 180384.

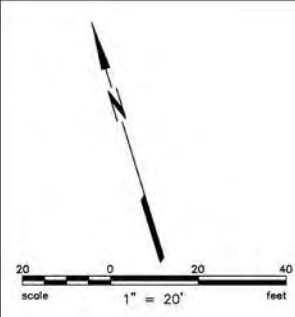

**SYMBOLS & LEGEND**

- EXISTING**
  - FOUND CITY OF OAKLAND MONUMENT
  - VALVE
  - FIRE HYDRANT
  - BACKFLOW PREVENTION DEVICE
  - RISER
  - SIGN
  - STREET LIGHT (UNLESS NOTED OTHERWISE)
  - LIGHT POLE (UNLESS NOTED OTHERWISE)
  - GUY ANCHOR
  - UTILITY POLE
  - TELEPHONE MANHOLE
  - MANHOLE
- SUBJECT PROPERTY** (dashed line)
- ADJOINING LOT** (dash-dot line)
- CENTERLINE** (dotted line)
- SURVEY TIE** (long dash-short dash line)
- STORM DRAIN** (line with 'SD' label)
- SANITARY SEWER** (line with 'SS' label)
- OVERHEAD UTILITY LINE** (line with 'OH' label)
- CONCRETE** (cross-hatched pattern)
- DETECTABLE WARNING** (star pattern)

**ABBREVIATIONS**

- AC ASPHALT CONCRETE
- CA CABLE
- CB CATCH BASIN
- CO CLEAN OUT
- COMM COMMUNICATION
- CONC CONCRETE
- DI DROP INLET
- DWY DRIVEWAY
- E ELECTRIC
- EP EDGE OF PAVEMENT
- FL SURFACE FLOWLINE
- G GAS
- GYP GUY POLE
- INV BOTTOM INSIDE OF PIPE
- LG LIP OF GUTTER
- M METER
- MH MANHOLE
- OH OVERHEAD UTILITY LINE
- SD STORM DRAIN
- SL STREETLIGHT
- SS SANITARY SEWER
- TC TOP FACE OF CURB
- TEL TELECOMMUNICATION LINE
- TG TOP OF GRATE
- TS TRAFFIC SIGNAL
- TV TELEVISION
- UB UTILITY BOX
- V VALVE
- VLT VAULT
- W WATER
- WM WATER METER



1646 N. CALIFORNIA BLVD.,  
SUITE 400  
WALNUT CREEK, CA 94596  
(925) 940-2200  
www.bkf.com

**BKF 100**  
YEARS  
ENGINEERS · SURVEYORS · PLANNERS

TOPOGRAPHIC AND BOUNDARY SURVEY  
WEST OAKLAND BART

CALIFORNIA  
COUNTY OF ALAMEDA

OAKLAND

Date:	No.	Revisions
12/06/2018		
Scale: AS SHOWN		
Design: N/A		
Drawn: ADD		
Approved: KS		
Job No: 180384		

Drawing Number:  
**180384**  
2 of 5

DRAWING NAME: N:\2018\180384\_West\_Oakland\_BART\_TG\_Survey\ASAP\Mapings\Topo\180384.dwg  
DATE: 12/06/18 10:30:18 AM

**SYMBOLS & LEGEND**

**EXISTING**

-  FOUND CITY OF OAKLAND MONUMENT
  -  VALVE
  -  FIRE HYDRANT
  -  BACKFLOW PREVENTION DEVICE
  -  RISER
  -  SIGN
  -  STREET LIGHT (UNLESS NOTED OTHERWISE)
  -  LIGHT POLE (UNLESS NOTED OTHERWISE)
  -  GUY ANCHOR
  -  UTILITY POLE
  -  TELEPHONE MANHOLE
  -  MANHOLE
- 
-  SUBJECT PROPERTY
  -  ADJOINING LOT
  -  CENTERLINE
  -  SURVEY TIE
  -  STORM DRAIN
  -  SANITARY SEWER
  -  OVERHEAD UTILITY LINE
  -  CONCRETE
  -  DETECTABLE WARNING

**ABBREVIATIONS**

- AC ASPHALT CONCRETE
- CA CABLE
- CB CATCH BASIN
- CO CLEAN OUT
- COMM COMMUNICATION
- CONC CONCRETE
- DI DROP INLET
- DWY DRIVEWAY
- E ELECTRIC
- EP EDGE OF PAVEMENT
- FL SURFACE FLOWLINE
- G GAS
- GYP GUY POLE
- INV BOTTOM INSIDE OF PIPE
- LG LIP OF GUTTER
- M METER
- MH MANHOLE
- OH OVERHEAD UTILITY LINE
- SD STORM DRAIN
- SL STREETLIGHT
- SS SANITARY SEWER
- TC TOP FACE OF CURB
- TEL TELECOMMUNICATION LINE
- TG TOP OF GRATE
- TS TRAFFIC SIGNAL
- TV TELEVISION
- UB UTILITY BOX
- V VALVE
- VLT VAULT
- W WATER
- WM WATER METER

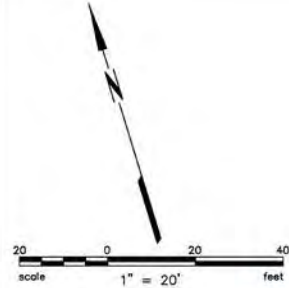

DRAWING NAME: K:\2018\180384\DWG\_180384.dwg, Date: 12/06/2018 11:53:24 AM, User: kst, Plot Date: 12/06/2018 11:53:24 AM

Revisions

No.	Date:	By:	Reason:
1	12/06/2018	AS SHOWN	N/A
2		ADD	KS
3		ADD	KS

Drawing Number:

180384

**SYMBOLS & LEGEND**

**EXISTING**

- FOUND CITY OF OAKLAND MONUMENT
- VALVE
- FIRE HYDRANT
- BACKFLOW PREVENTION DEVICE
- RISER
- SIGN
- STREET LIGHT (UNLESS NOTED OTHERWISE)
- LIGHT POLE (UNLESS NOTED OTHERWISE)
- GUY ANCHOR
- UTILITY POLE
- TELEPHONE MANHOLE
- MANHOLE

**ABBREVIATIONS**

- AC ASPHALT CONCRETE
- CA CABLE
- CB CATCH BASIN
- CO CLEAN OUT
- COMM COMMUNICATION
- CONC CONCRETE
- DI DROP INLET
- DWY DRIVEWAY
- E ELECTRIC
- EP EDGE OF PAVEMENT
- FL SURFACE FLOWLINE
- G GAS
- GYP GUY POLE
- INV BOTTOM INSIDE OF PIPE
- LG LIP OF GUTTER
- M METER
- MH MANHOLE
- OH OVERHEAD UTILITY LINE
- SD STORM DRAIN
- SL STREETLIGHT
- SS SANITARY SEWER
- TC TOP FACE OF CURB
- TEL TELECOMMUNICATION LINE
- TG TOP OF GRATE
- TS TRAFFIC SIGNAL
- TV TELEVISION
- UB UTILITY BOX
- V VALVE
- VLT VAULT
- W WATER
- WM WATER METER

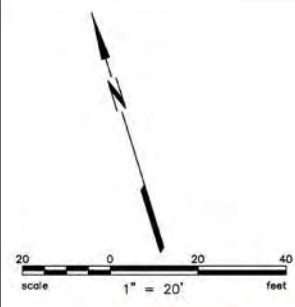

1646 N. CALIFORNIA BLVD.,  
SUITE 400  
WALNUT CREEK, CA 94596  
(925) 940-2200  
www.bkf.com

**BKF 100 YEARS**  
ENGINEERS, SURVEYORS, PLANNERS

TOPOGRAPHIC AND BOUNDARY SURVEY  
WEST OAKLAND BART

CALIFORNIA  
COUNTY OF ALAMEDA

Revisions	
No.	Description

Date: 12/06/2018  
Scale: AS SHOWN  
Design: N/A  
Drawn: ADD  
Approved: KS  
Job No: 180384

Drawing Number:  
**180384**

4 of 5

DRAWING NAME: K:\2018\180384\West Oakland BART\_Topo\_Survey\ASAP\Maping\Topo\180384.dwg  
DATE: 12/06/2018 10:00:00 AM  
USER: JTB

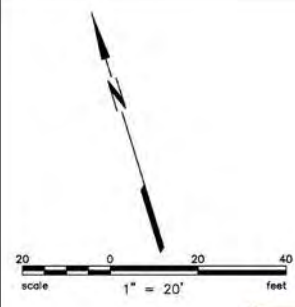

**SYMBOLS & LEGEND**

<b>EXISTING</b>	
	FOUND CITY OF OAKLAND MONUMENT
	VALVE
	FIRE HYDRANT
	BACKFLOW PREVENTION DEVICE
	RISER
	SIGN
	STREET LIGHT (UNLESS NOTED OTHERWISE)
	LIGHT POLE (UNLESS NOTED OTHERWISE)
	UTILITY POLE
	GUY ANCHOR
	TELEPHONE MANHOLE
	MANHOLE
	SUBJECT PROPERTY
	ADJOINING LOT
	CENTERLINE
	SURVEY TIE
	STORM DRAIN
	SANITARY SEWER
	OVERHEAD UTILITY LINE
	CONCRETE
	DETECTABLE WARNING

**ABBREVIATIONS**

AC	ASPHALT CONCRETE
CA	CABLE
CB	CATCH BASIN
CO	CLEAN OUT
COMM	COMMUNICATION
CONC	CONCRETE
DI	DROP INLET
DWY	DRIVEWAY
E	ELECTRIC
EP	EDGE OF PAVEMENT
FL	SURFACE FLOWLINE
G	GAS
GYP	GUY POLE
INV	BOTTOM INSIDE OF PIPE
LG	LIP OF GUTTER
M	METER
MH	MANHOLE
OH	OVERHEAD UTILITY LINE
SD	STORM DRAIN
SL	STREETLIGHT
SS	SANITARY SEWER
TC	TOP FACE OF CURB
TEL	TELECOMMUNICATION LINE
TG	TOP OF GRATE
TS	TRAFFIC SIGNAL
TV	TELEVISION
UB	UTILITY BOX
V	VALVE
VL	VAULT
W	WATER
WM	WATER METER



1646 N. CALIFORNIA BLVD.,  
SUITE 400  
WALNUT CREEK, CA 94596  
(925) 940-2200  
www.bkf.com

**BKF 100 YEARS**  
ENGINEERS · SURVEYORS · PLANNERS

CALIFORNIA  
COUNTY OF ALAMEDA

TOPOGRAPHIC AND BOUNDARY SURVEY  
WEST OAKLAND BART

Date:	12/06/2018
Scale:	AS SHOWN
Design:	N/A
Drawn:	ADD
Approved:	KS
Job No.:	180384

Revisions

No.	
-----	--

Drawing Number:  
**180384**

5 of 5

DRAWING NAME: K:\Projects\180384\180384\_001\180384\_001.dwg; DATE: 12/06/2018 10:00:00 AM; USER: jason; PLOT DATE: 12/06/2018 10:00:00 AM; PLOT USER: jason

# VESTING TENTATIVE PARCEL MAP NO. 10940

## FOR CONDOMINIUM PURPOSES

Revisions	
04/06/2020	AS SHOWN
	BY CG
	IN CC
	ISSUED ES
	No20180384

TENTATIVE  
PARCEL MAP  
C-1.01A

### SHEET INDEX

SHEET #	SHEET TITLE
1	TITLE SHEET/EXISTING SITE PLAN
2	PROPOSED SITE PLAN
3	EMERGENCY VEHICLE ACCESS EASEMENT

### SYMBOLS & LEGEND

EXISTING	
	VALVE
	FIRE HYDRANT
	BACKFLOW PREVENTION DEVICE
	RISER
	SIGN
	STREET LIGHT
	LIGHT POLE
	GUY ANCHOR
	UTILITY POLE
	TELEPHONE MANHOLE
	MANHOLE
	EXISTING PROPERTY LINE
	ADJOINING LOT
	CENTERLINE
	SURVEY TIE
	STORM DRAIN
	SANITARY SEWER
	OVERHEAD UTILITY LINE
	CONCRETE
	DETECTABLE WARNING
	BOUNDARY LINE

### ABBREVIATIONS

AC	ASPHALT CONCRETE
CA	CABLE
CB	CATCH BASIN
CO	CLEAN OUT
COMM	COMMUNICATION
CONC	CONCRETE
DBH	DIAMETER AT BREAST HEIGHT
DI	DROP INLET
DWY	DRIVEWAY
E	ELECTRIC
EP	EDGE OF PAVEMENT
EVAE	EMERGENCY VEHICLE ACCESS EASEMENT
FL	SURFACE FLOWLINE
G	GAS
GYP	GUY POLE
INV	BOTTOM INSIDE OF PIPE
LG	LIP OF GUTTER
M	METER
MH	MANHOLE
MIN	MINIMUM
OH	OVERHEAD UTILITY LINE
PL	PROPERTY LINE
R	RADIUS
SD	STORM DRAIN
SF	SQUARE FEET
SL	STREETLIGHT
SS	SANITARY SEWER
(T)	TOTAL
TC	TOP FACE OF CURB
TEL	TELECOMMUNICATION LINE
TG	TOP OF GRATE
TS	TRAFFIC SIGNAL
TV	TELEVISION
UB	UTILITY BOX
V	VALVE
VLT	VAULT
W	WATER
WM	WATER METER

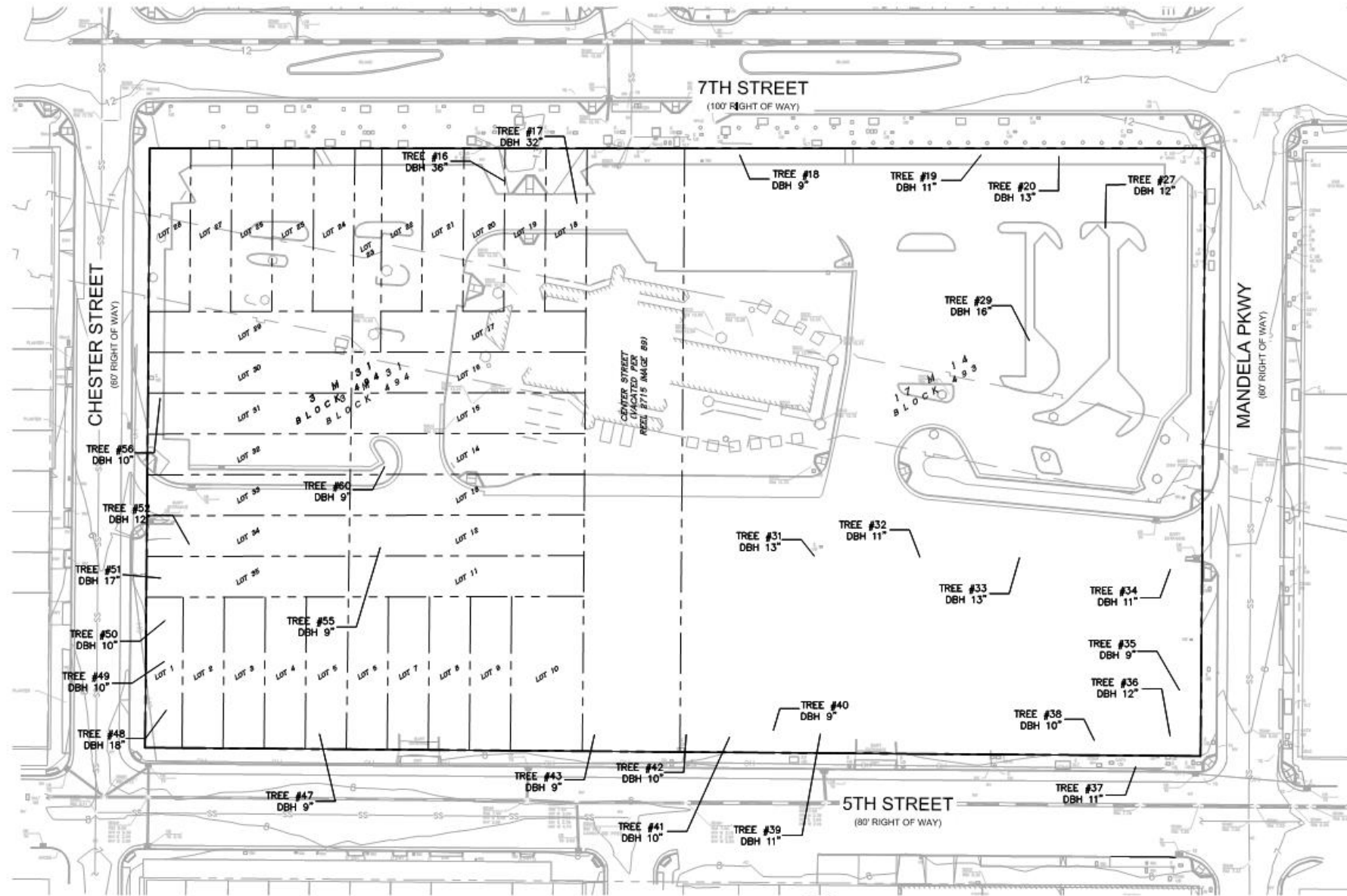

EXISTING CONDITIONS  
SCALE 1"=40'

Tree number	DBH (in)	Species Name
16	36	Pinus Pinea
17	32	Pinus Pinea
20	13	Liriodendron Tulipifera
28	12	Maytenus Boaria
29	16	Maytenus Boaria
31	13	Liriodendron Tulipifera
33	13	Liriodendron Tulipifera
36	12	Liriodendron Tulipifera
48	18	Platanus X Acerifolia
51	17	Platanus X Acerifolia
52	12	Liriodendron Tulipifera

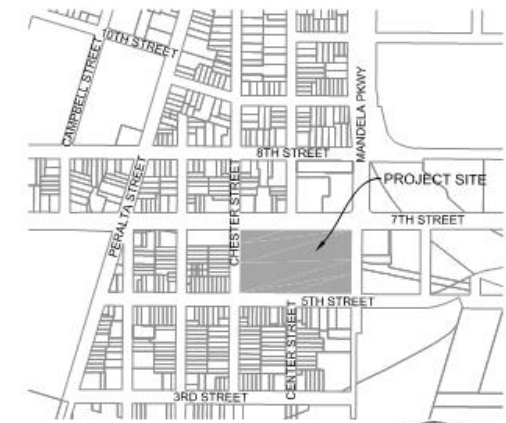

KEY MAP  
SCALE 1"=500'

PROPERTY ADDRESS:  
1451 7TH STREET  
OAKLAND, CA 94607

OWNER AND SUBDIVIDER:  
SAN FRANCISCO BAY AREA RAPID TRANSIT DISTRICT  
300 LAKESIDE DRIVE, 22ND FLOOR  
OAKLAND, CA 94612  
PHONE: 510-597-6300

### BASIS OF BEARINGS

THE BEARING OF NORTH 72°53'28" WEST BETWEEN FOUND MONUMENTS ON 5TH STREET BETWEEN HENRY STREET AND KIRKHAM STREET AS SHOWN ON THAT RECORD OF SURVEY, R/S 1687, FILED AUGUST 7, 2000 IN BOOK 25 OF RECORDS OF SURVEY AT PAGES 58-69, INCLUSIVE, ALAMEDA COUNTY RECORDS, WAS TAKEN AS THE BASIS OF BEARINGS FOR THIS SURVEY.

### BENCHMARK

THE ELEVATIONS SHOWN HEREON ARE BASED ON A FOUND CITY OF OAKLAND BENCHMARK, DESIGNATION 25/H, BEING A BRONZE DISK STAMPED, "SEC 25 STA H." ELEVATION 10.784 FEET (DATUM = MEAN SEA LEVEL).

### NOTES

- BASED ON INFORMATION CONTAINED IN THE PRELIMINARY TITLE REPORT, ORDER NUMBER NCS-891862-SC, DATED JANUARY 31, 2018, PROVIDED BY FIRST AMERICAN TITLE COMPANY, THE SUBJECT PROPERTY IS OWNED BY SPBART BEING ASSESSOR PARCEL NUMBERS 004-0077-003, 004-0071-003, AND THE VACATION OF CENTER STREET; THERE ARE 36 PARCELS, NOT INCLUDING THE VACATION OF CENTER STREET. THE EXISTING PARCELS WILL BE RECONFIGURED TO CREATE 3 LOTS AND ONE REMAINDER PARCEL VIA PARCEL MAP TO BE PROCESSED.
- THE INTENT OF THE MAP IS TO MERGE THE 36 PARCELS AND THE VACATED CENTER STREET INTO THE FOUR CONSOLIDATE PARCELS DEFINING THE KEY COMPONENTS OF THE NEW DEVELOPMENT: LOT 1 MARKET RATE RESIDENTIAL TOWER, LOT 2 OFFICE BUILDING, LOT 3 AFFORDABLE HOUSING, AND THE DESIGNATED REMAINDER PARCEL FOR THE EXISTING WEST OAKLAND BART STATION AND NEW ENTRY PLAZAS.
- THE CONTROL SURVEY WAS CONDUCTED IN NOVEMBER OF 2018.
- ALL UNITS ARE IN US SURVEY FEET AND DECIMALS THEREOF.
- THE TOPOGRAPHIC SURVEY IS BASED ON A FIELD SURVEY COMPLETED IN DECEMBER 2018.
- ALL BUILDINGS TO THE NORTH OF THE BART STATION SHALL BE 30' FROM THE BART PLATFORM, AND ALL BUILDINGS TO THE SOUTH OF THE BART STATION SHALL BE 33' FROM THE BART PLATFORM.
- ALL EMERGENCY VEHICLE ACCESS EASEMENTS SHALL BE 26' WIDE.
- LOTS 1, 2 AND 3 ARE ALLOWED UP TO FOUR COMMERCIAL CONDOMINIUMS ON EACH LOT.
- MULTIPLE MAPS MAY BE FILED FOR THIS PROJECT.

### SURVEYOR'S STATEMENT:

THIS MAP CORRECTLY REPRESENTS A SURVEY MADE BY ME OR UNDER MY DIRECTION IN CONFORMANCE WITH THE REQUIREMENTS OF THE PROFESSIONAL LAND SURVEYOR'S ACT.

PAUL KITTRIDGE  
PROJECT MANAGER  
P.L.S. # 5790



DATE: \_\_\_\_\_



Revisions	No.	Date
AS SHOWN		04/06/2020
CG		
CC		
Drawn ES		
No. 20180384		

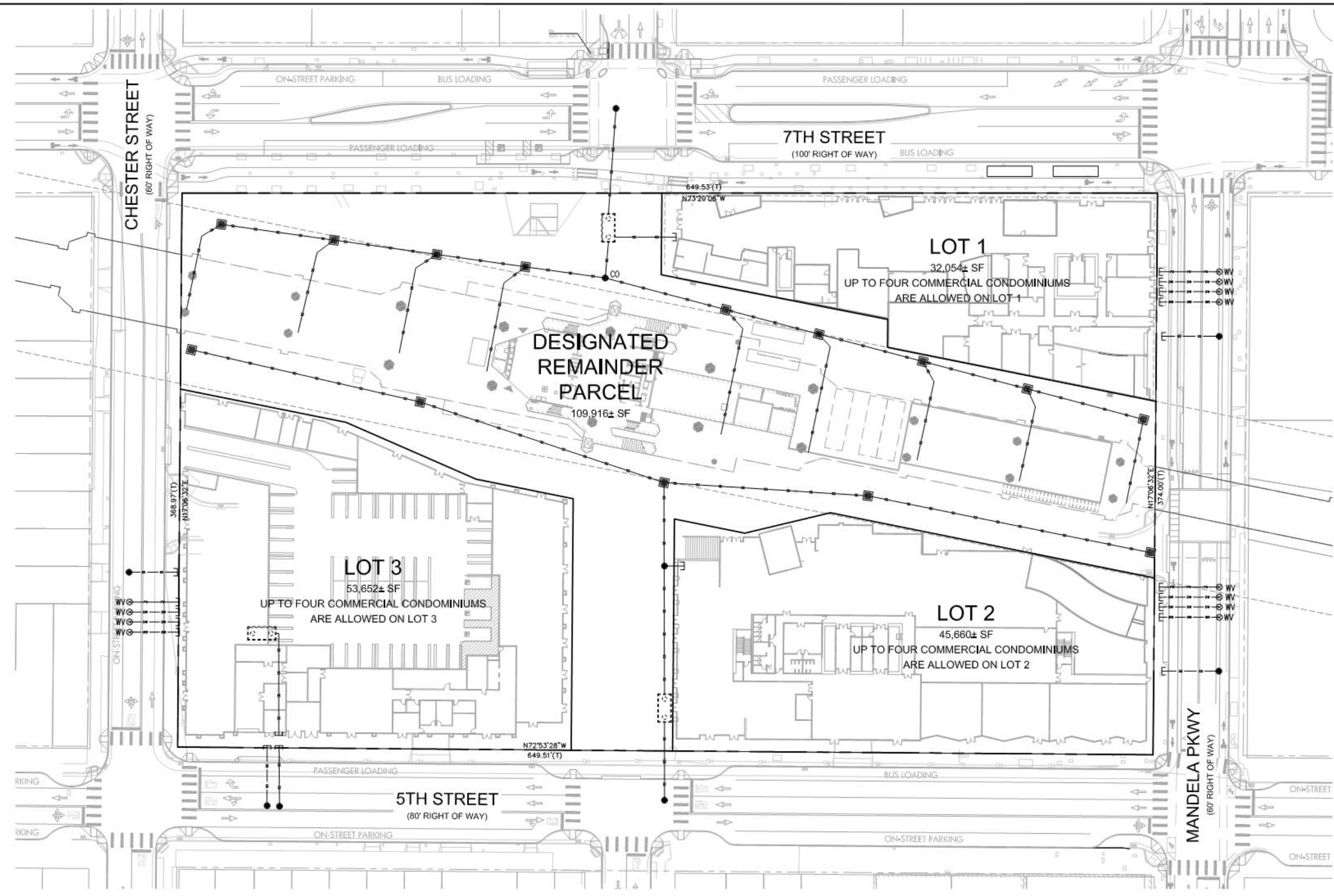

DRAWING NAME: K:\2018\180384\_West\_Oakland\_BART\_100\_Survey\ENG\TENTATIVE PARCEL MAP\MAP SHEETS\02\02\MPL.dwg  
PLOT DATE: 04-06-20 PLOTTED BY: mlr

**LEGEND**  
BOUNDARY LINE  
PROPOSED PARCEL LINE

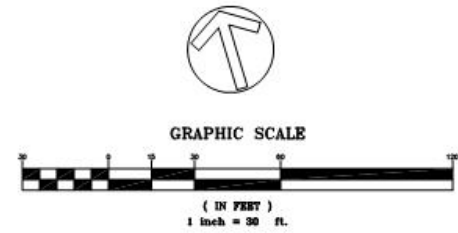
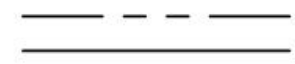

**TENTATIVE PARCEL MAP**  
**C-1.01B**

Revisions	No.	Date
AS SHOWN		04/06/2020
BY CG		
IN CC		
ISSUED ES		
No. 20180384		

TENTATIVE  
PARCEL MAP  
C-1.01C

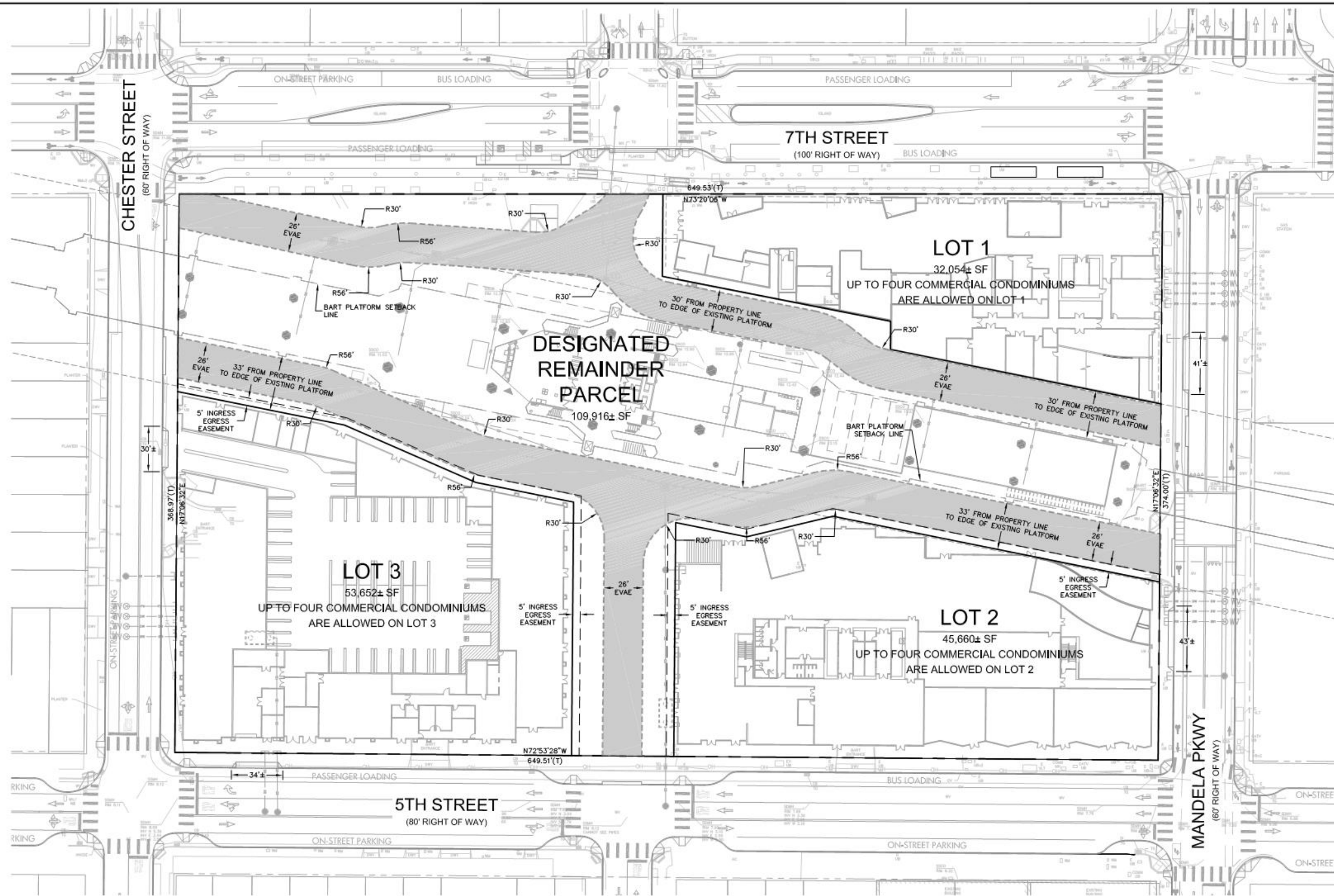

EMERGENCY VEHICLE ACCESS EASEMENT

- LEGEND**
- PROPOSED EVAE
  - BOUNDARY LINE
  - PROPOSED PARCEL LINE

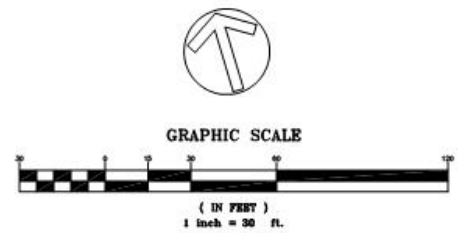
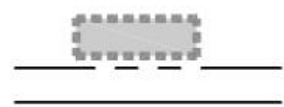

DRAWING NAME: K:\2018\180384 West\_Oakland\_BART\_100\_Survey\ENG\TENTATIVE PARCEL MAP\SHEETS\OSWOB1MEA.dwg  
PLOT DATE: 04-06-20 PLOTTED BY: mlr

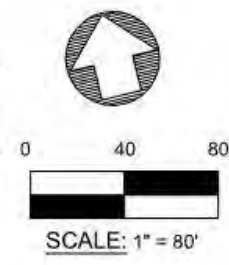
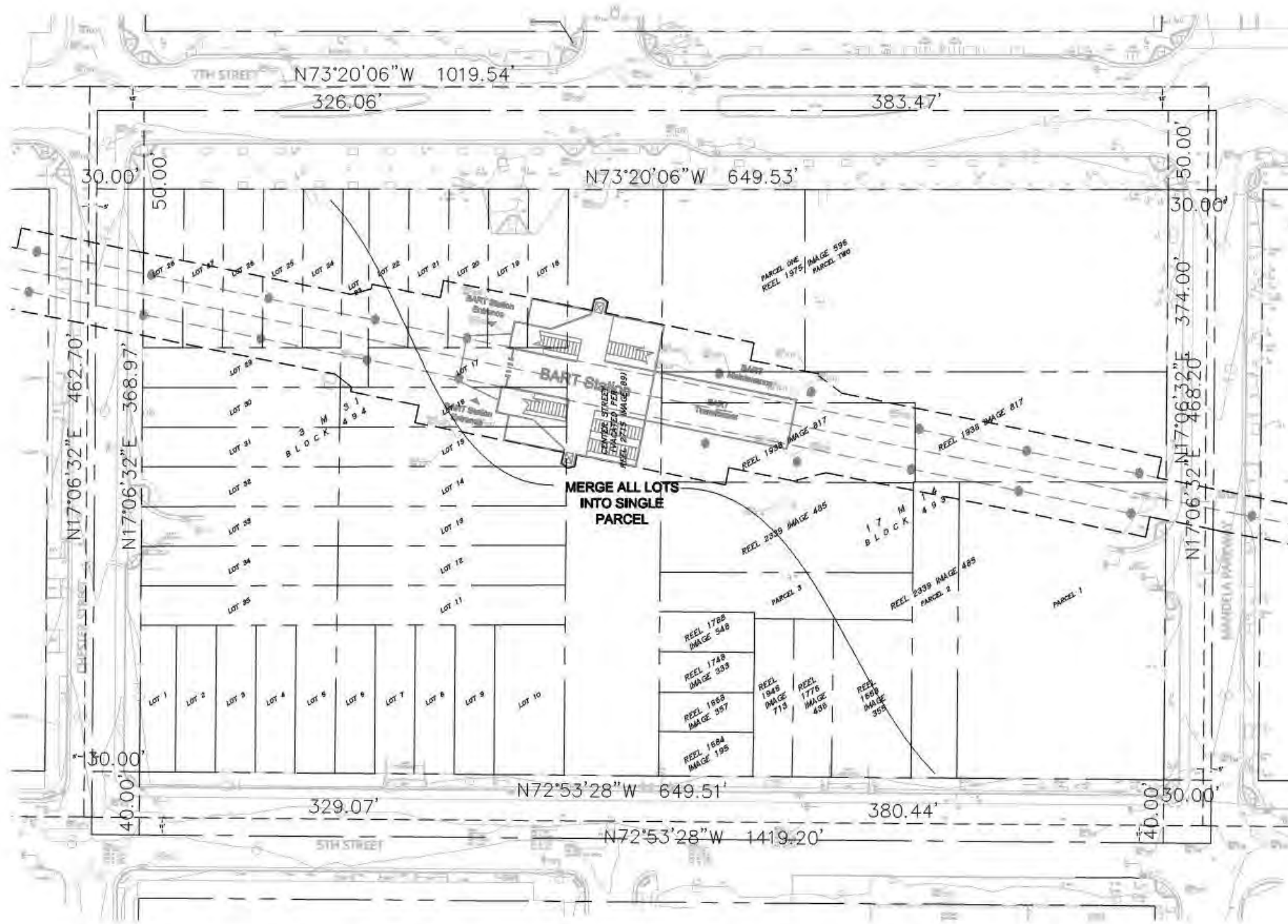

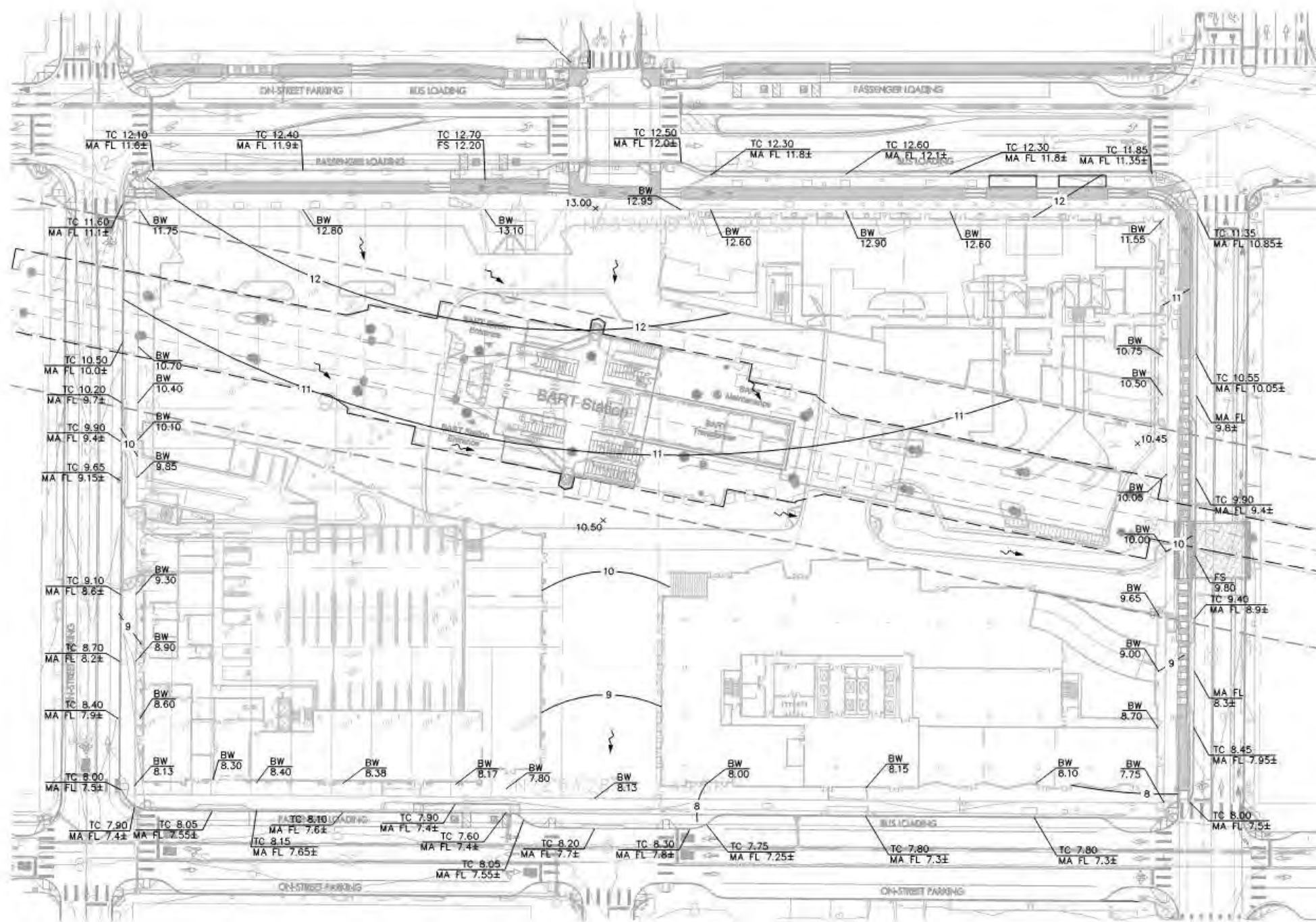

**ABBREVIATIONS:**

FF	FINISHED FLOOR
FG	FINISHED GROUND
FS	FINISHED SURFACE
FL	FLOW LINE
MA	MATCH
TC	TOP OF CURB
TS	TOP OF STEP
TW	TOP OF WALL

**LEGEND:**

	DIRECTION OF PROPOSED DRAINAGE
	GRADE BREAK
	5.00' CONTOUR

**GRADING NOTES:**

1. TC ELEVATIONS ARE 6" ABOVE ADJACENT PAVEMENT FL ELEVATIONS, UNLESS OTHERWISE NOTED ON PLAN.

**EARTHWORK SUMMARY:**

TOTAL EXCAVATION: 51,303 CUBIC YARDS  
 TOTAL FILL: 0 CUBIC YARDS  
 TOTAL OFFHAUL: 51,303 CUBIC YARDS

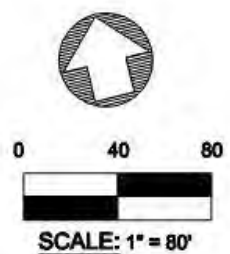

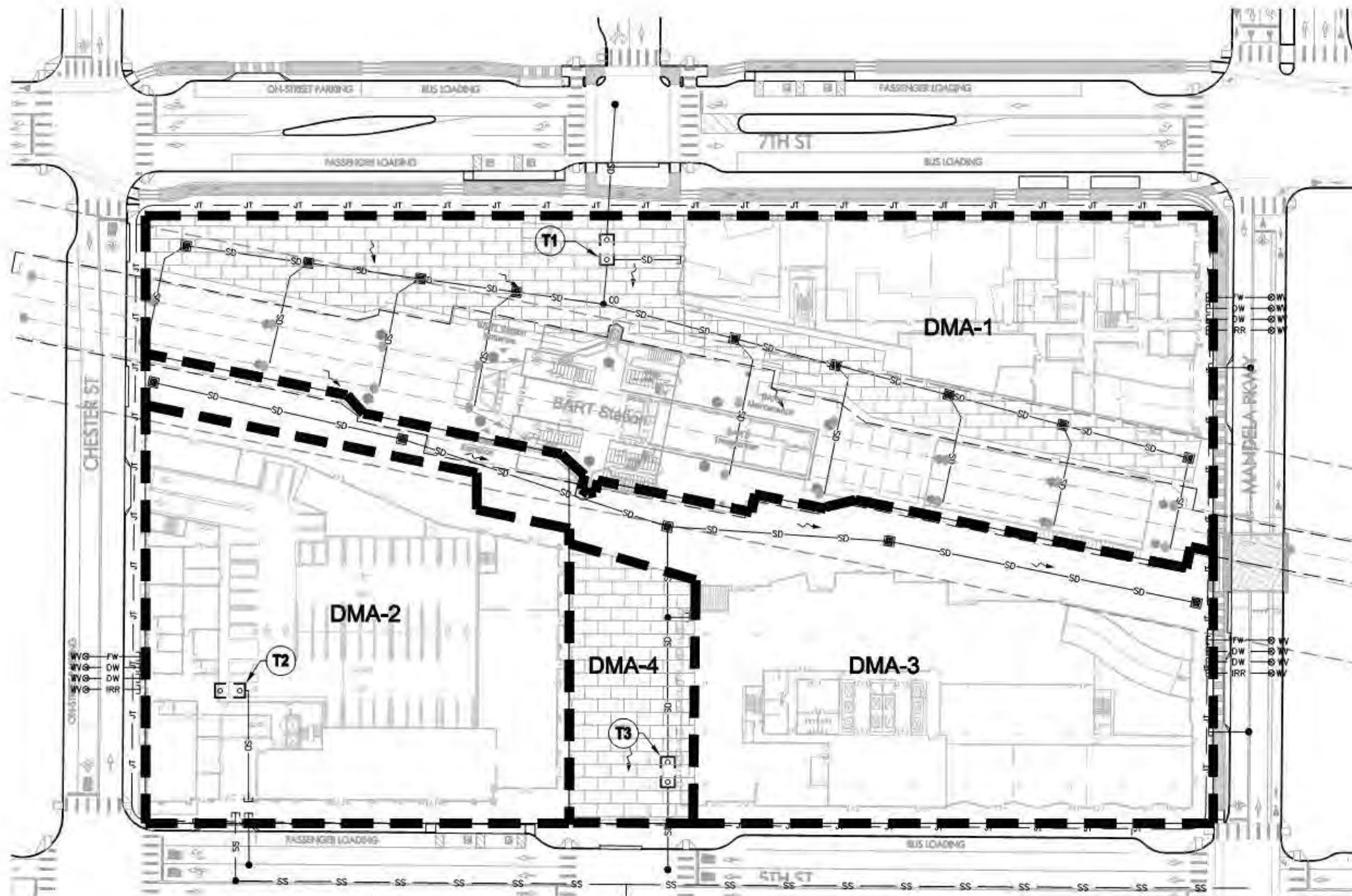

**LEGEND:**

- DRAINAGE MANAGEMENT AREA (DMA)
- PERMEABLE PAVING
- FILTER VAULT  
SEE SHEET C3.01
- TREATMENT AREA LABEL

**STORMWATER MANAGEMENT NOTES:**

1. THE TREATMENT VAULTS WERE SELECTED BASED ON 243,131 SF OF IMPERVIOUS SURFACE AND A TREATMENT INTENSITY OF 0.2 IN/HR. SEE OLD CASTLE WASHINGTON GULD PF-V-B-WA-0001 PERK FILTER DETAIL ON SHEET C3.01. ALL FILTER VAULTS SHOWN ARE COMPRISED OF (31) - 18" CARTRIDGES.

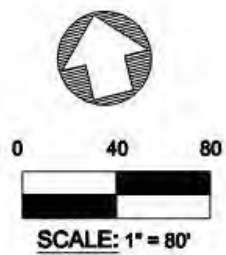

TOTAL SITE AREA (SF)	TOTAL LAND AREA DISTURBED (SF)	TOTAL EXISTING/PRE-PROJECT IMPERVIOUS SURFACE (SF)	REPLACED IMPERVIOUS SURFACE (SF)	NEW IMPERVIOUS SURFACE (SF)	TOTAL POST-PROJECT IMPERVIOUS SURFACE (SF)
243,130	243,130	212,865	177,410	25,135	202,545

DMA	Impervious Area (SF)	Pervious Area (SF)	Treatment Type	Designated Treatment Area
1	74,600	28,445	Filter Vault	T1
2	58,278	0	Filter Vault	T2
3	69,667	0	Filter Vault	T3
4	0	12,140	Permeable Paving	T4

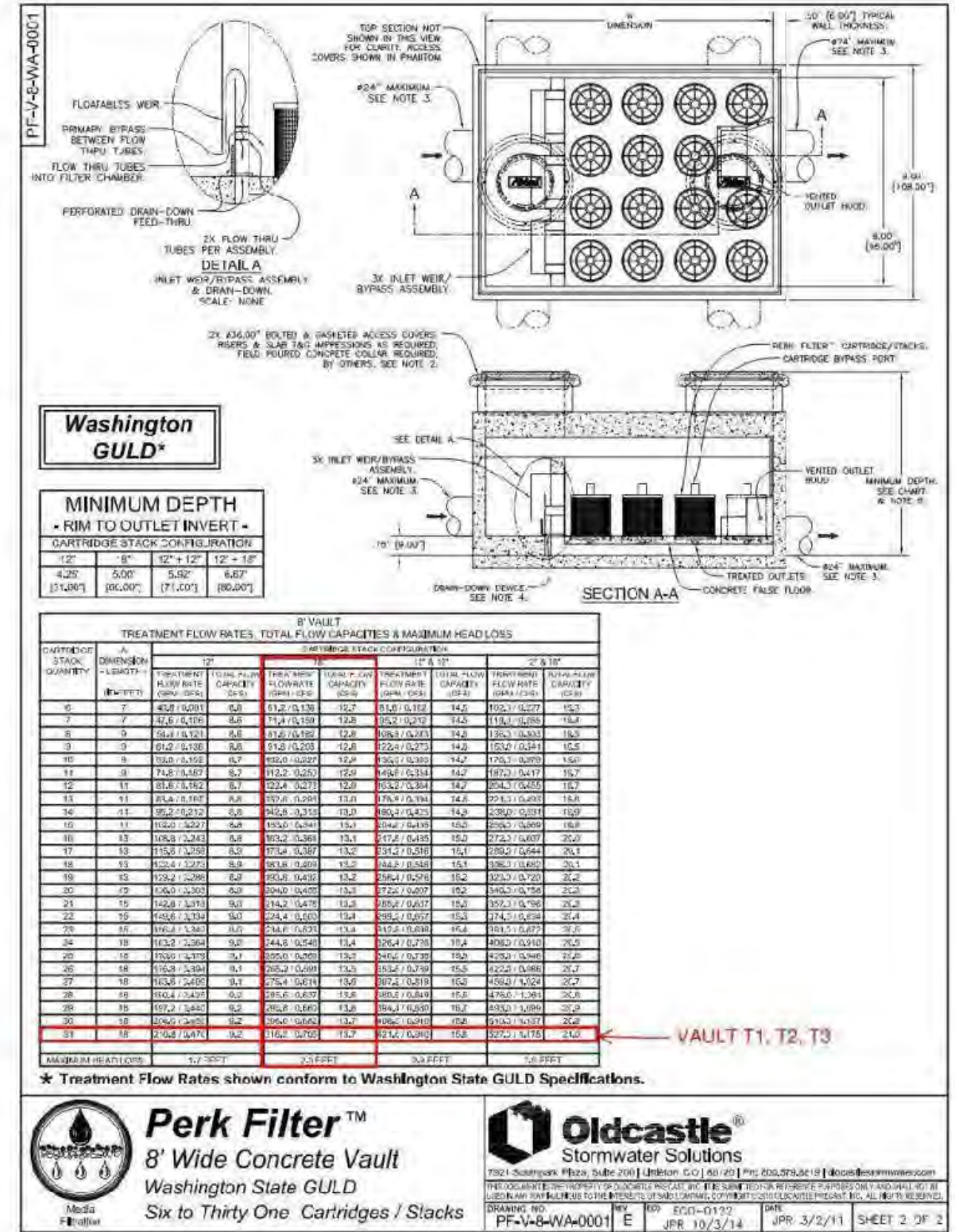
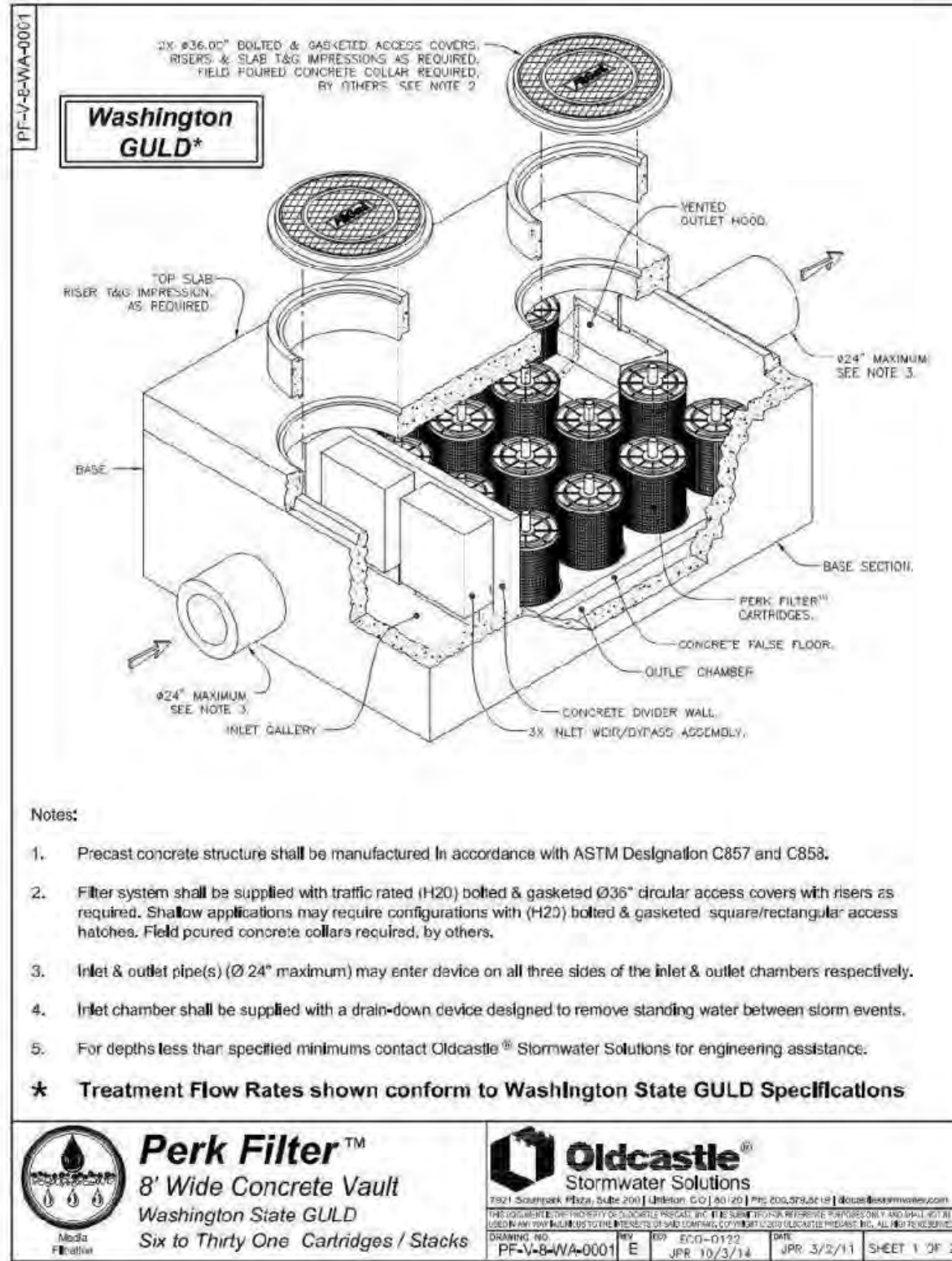



## Special Projects

### Non-I.I.D Treatment Summary

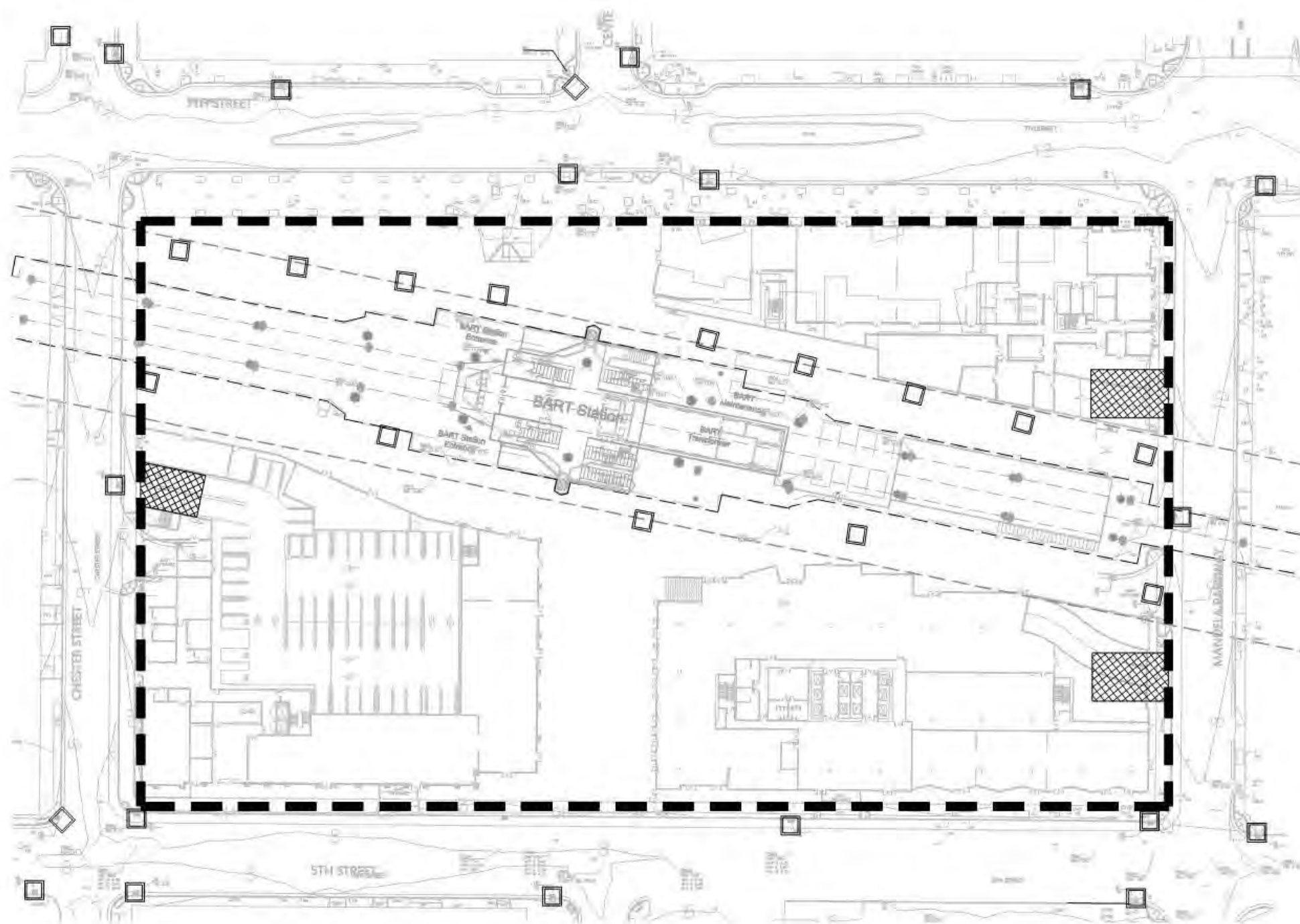
Category	Impervious Area Created/Replaced (acres)	Site Coverage (%)	Project Density or FAR	Density/Criteria	Allowable Credit (%)	Applied Credit (%)
A			N.A.	N.A.	100%	
B				Res $\geq$ 50 DU/ac or FAR $\geq$ 2:1	50%	
				Res $\geq$ 75 DU/ac or FAR $\geq$ 3:1	75%	
				Res $\geq$ 100 DU/ac or FAR $\geq$ 4:1	100%	
C				<b>Location credit (select one)<sup>5</sup>:</b>		
				Within 1/4 mile of transit hub	50%	50%
				Within 1/2 mile of transit hub	25%	
				Within a planned PDA	25%	
				<b>Density credit (select one):</b>		
				Res $\geq$ 30 DU/ac or FAR $\geq$ 2:1	10%	
				Res $\geq$ 60 DU/ac or FAR $\geq$ 4:1	20%	
				Res $\geq$ 100 DU/ac or FAR $\geq$ 6:1	30%	30%
				<b>Parking credit (select one):</b>		
				$\geq$ 10% at-grade surface parking <sup>6</sup>	10%	
No surface parking	20%	20%				
<b>TOTAL TOD CREDIT =</b>					<b>100%</b>	



**EROSION CONTROL LEGEND:**

-  STABILIZED CONSTRUCTION ENTRANCE (TC-1)\*\* WITH ENTRANCE/OUTLET TIRE WASH (TC-3)\*\*
-  STORM DRAIN INLET PROTECTION (SC-10)\*\*
-  FIBER ROLL (SC-05)\*\*

\*\*REFER TO SHEET C4.01 FOR DETAILS

**EROSION CONTROL NOTES:**

1. SITE ACCESS SHOWN ON THIS PLAN IS PROVIDED FOR INFORMATION PURPOSES ONLY. CONTRACTOR SHALL LOCATE CONSTRUCTION ACCESS DRIVEWAYS AS NECESSARY.
2. EROSION AND SEDIMENT CONTROL MEASURES SHALL BE IN EFFECT AND MAINTAINED BY THE CONTRACTOR ON A YEAR-ROUND BASIS UNTIL ALL DISTURBED AREAS ARE STABILIZED UNLESS OTHERWISE PERMITTED BY THE COUNTY INSPECTOR.
3. ALL INLETS RECEIVING STORM WATER RUNOFF FROM THE PROJECT AREA MUST BE EQUIPPED WITH REQUIRED INLET PROTECTION.
4. ALL PAVED AREAS SHALL BE KEPT CLEAR OF EARTH MATERIALS AND DEBRIS. THE SITE SHALL BE MAINTAINED SO AS TO MINIMIZE SEDIMENT LADEN RUNOFF ENTERING THE STORM DRAIN SYSTEM.
5. STOCKPILED EARTHEN MATERIAL SHALL BE EITHER COVERED WITH A TARP OR WATERED SUFFICIENTLY TO ELIMINATE DUST.
6. REFERENCE: "CALIFORNIA STORM WATER BEST MANAGEMENT PRACTICE (BMP) HANDBOOK", JANUARY 2015.



0 40 80



SCALE: 1" = 80'



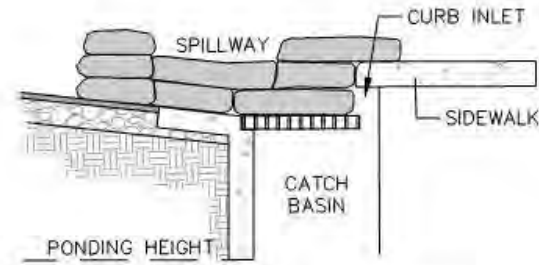
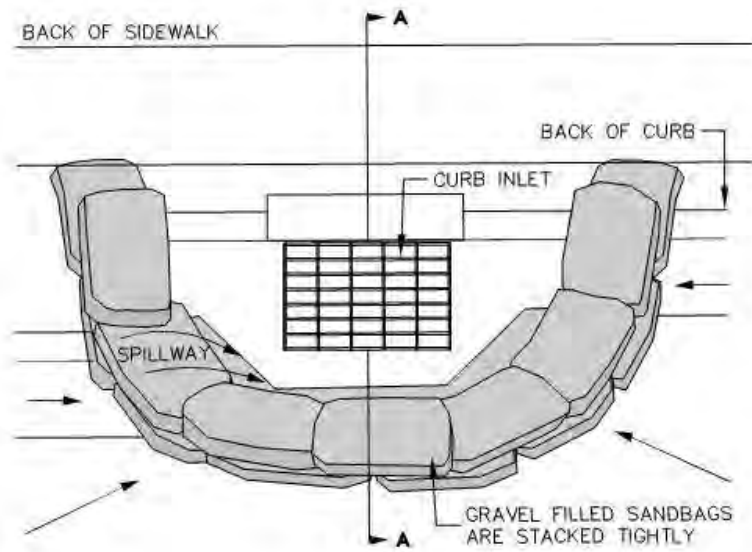

SECTION A-A

NOTES:

1. PLACE CURB TYPE SEDIMENT BARRIERS ON GENTLY SLOPING STREET SEGMENTS, WHERE WATER CAN POND AND ALLOW SEDIMENT TO SEPARATE FROM RUNOFF.
2. SANDBAGS OF EITHER BURLAP OR WOVEN 'GEOTEXTILE' FABRIC, ARE FILLED WITH GRAVEL LAYERED AND PACKED TIGHTLY.
3. LEAVE A ONE SANDBAG GAP IN THE TOP ROW TO PROVIDE A SPILLWAY FOR OVERFLOW.
4. INSPECT BARRIERS AND REMOVE SEDIMENT AFTER EACH STORM EVENT. SEDIMENT AND GRAVEL MUST BE REMOVED FROM THE TRAVELED WAY IMMEDIATELY.

① CURB INLET SEDIMENT BARRIER  
NOT TO SCALE

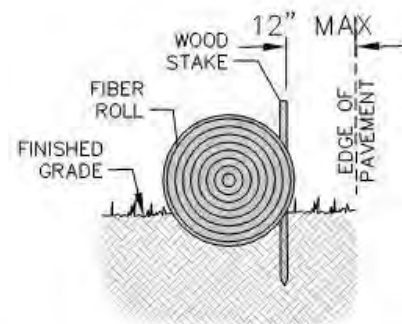

ENTRENCHMENT DETAIL  
IN FLAT AREA

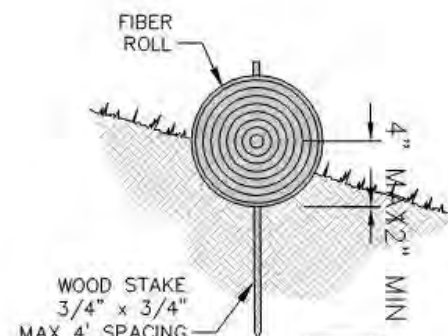

ENTRENCHMENT DETAIL  
IN SLOPED AREA

NOTES:

1. FIBER ROLLS ARE TUBES MADE FROM POROUS BIODEGRADABLE FIBER STUFFED IN A PHOTO-DEGRADABLE OPEN WEAVE NETTING. THEY ARE APPROXIMATELY 8" DIAMETER.
2. FIBER ROLL INSTALLATION REQUIRES THE PLACEMENT AND SECURE STAKING OF THE ROLL IN A TRENCH; 2"-4" DEEP, DUG ON CONTOUR. RUNOFF MUST NOT BE ALLOWED TO RUN UNDER OR AROUND ROLL. ROLLS SHOULD BE ABUTTED SECURELY TO PROVIDE A TIGHT JOINT, NOT OVERLAPPED.

② FIBER ROLL  
NOT TO SCALE

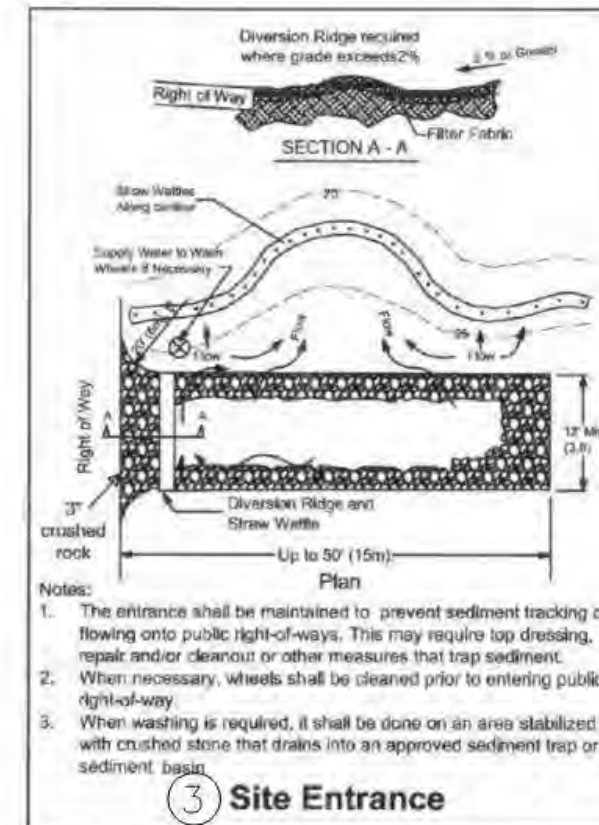

Notes:

1. The entrance shall be maintained to prevent sediment tracking or flowing onto public right-of-ways. This may require top dressing, repair and/or cleanout or other measures that trap sediment.
2. When necessary, wheels shall be cleaned prior to entering public right-of-way.
3. When washing is required, it shall be done on an area stabilized with crushed stone that drains into an approved sediment trap or sediment basin.

③ Site Entrance

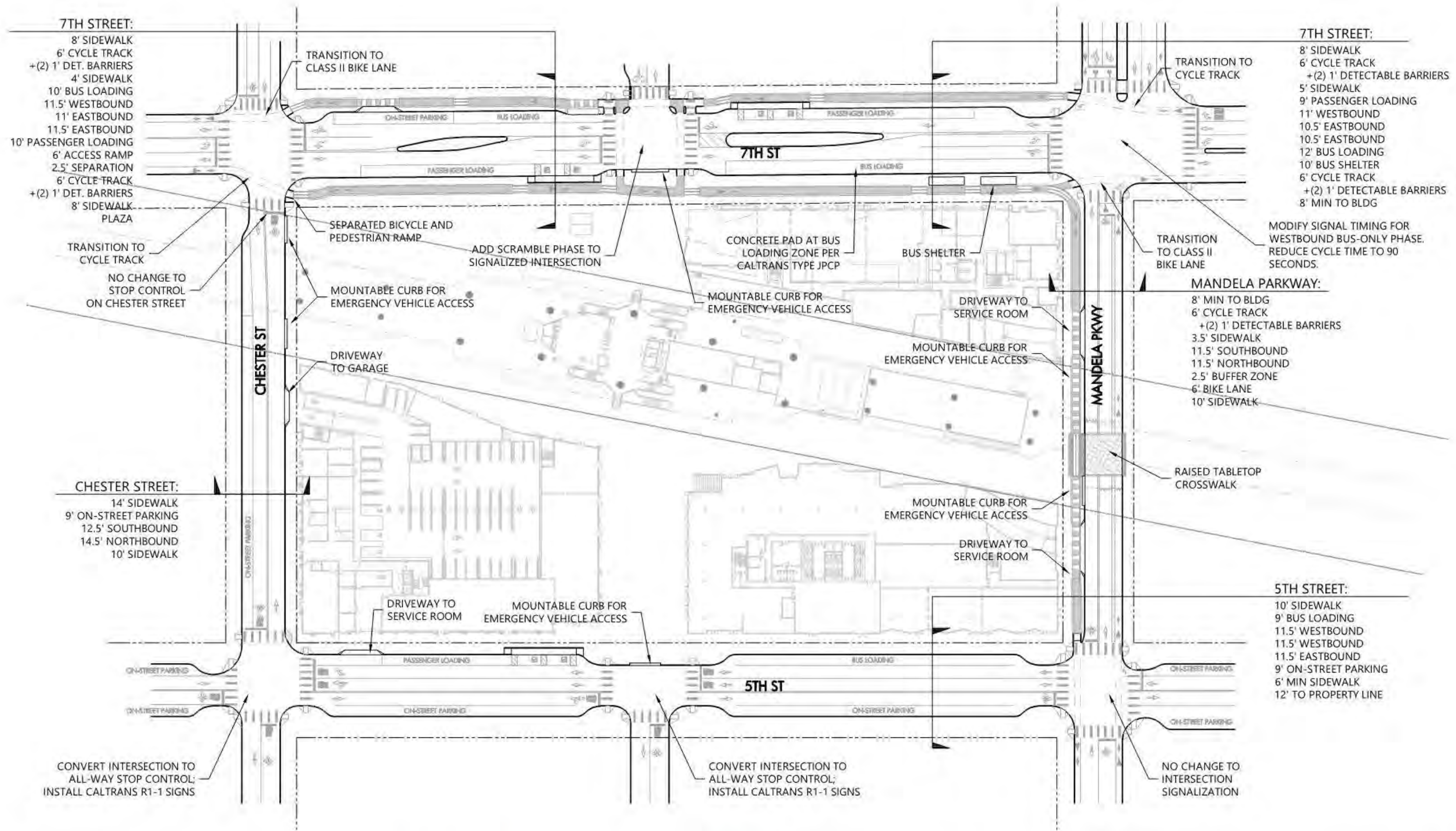



CYCLE TRACK CASE STUDY



CYCLE TRACK CASE STUDY

**Rendering of Better Market Street with trapezoidal delineator between pedestrians and bicycles**

Source:  
San Francisco Public Works  
Better Market Street Project

Trapezoidal delineator

Enhancing Mobility, Access and Safety for Pedestrians (Part II)

**Recommendation**  
Use a trapezoidal indicator between bicycle and pedestrian sides of a separated bikeway at sidewalk level

PLAN, Regular Tile: 12.00" (300 mm) width, 12.00" (300 mm) height

PLAN, End Tile: 12.00" (300 mm) width, 12.00" (300 mm) height

SECTION: 10.00" (250 mm) top width, 6.25" (150 mm) bottom width, 1.00" (25 mm) height

DETAIL: 1.875" (48 mm) top width, 1.00" (25 mm) bottom width, 0.75" (19 mm) height, 22° angle

**DETAIL 1 - LANE DROP**

CONTINUE 1-WAY CLEAR REFLECTIVE MARKERS AT 12'

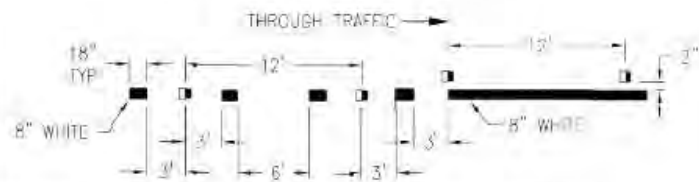

**DETAIL 2 - LANE LINE EXTENSIONS THROUGH INTERSECTIONS**



**DETAIL 3 - CROSSWALKS**



**DETAIL 4 - LEFT EDGE LINE**

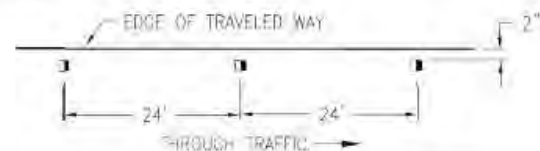

CONTINUE 1-WAY YELLOW REFLECTIVE MARKERS AT 24'

WITH REFLECTIVE STRIPS (EXPOSED) AND MAY BE AT INTERSECTIONS. THE SUFFICIENCY OF CLEARANCE SHALL BE MAINTAINED THROUGHOUT THE PROJECT. THIS SHALL BE THE RESPONSIBILITY OF THE CONTRACTOR.

CITY OF OAKLAND DESIGN AND CONSTRUCTION SERVICES DEPARTMENT



PAVEMENT MARKING  
DETAIL

TRANSPORTATION SERVICES MANAGER
DATE: JANUARY 2020
REV: 04/20
T-3

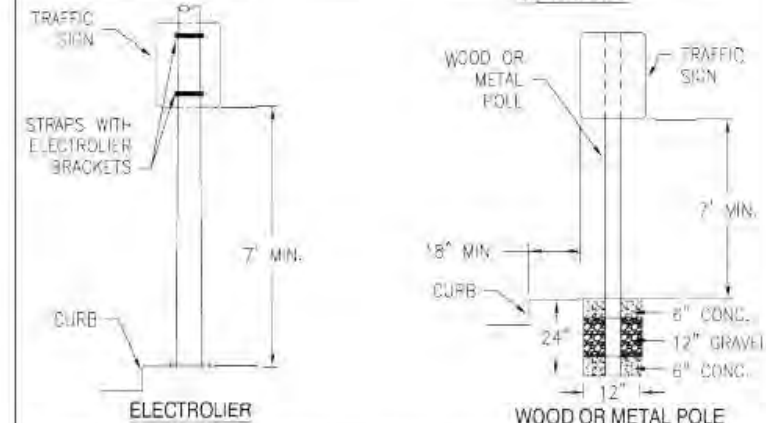
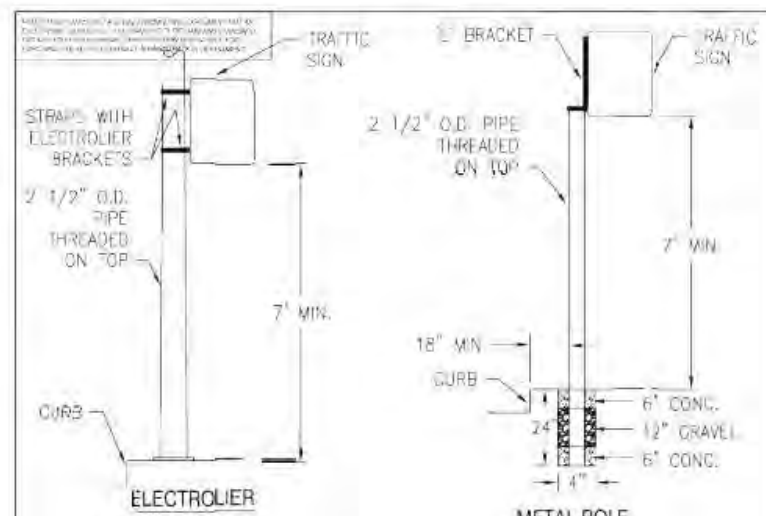

CITY OF OAKLAND DESIGN AND CONSTRUCTION SERVICES DEPARTMENT



SIGN INSTALLATION  
DETAILS

TRANSPORTATION SERVICES MANAGER
DATE: JANUARY 2020
REV: 04/20
T-4

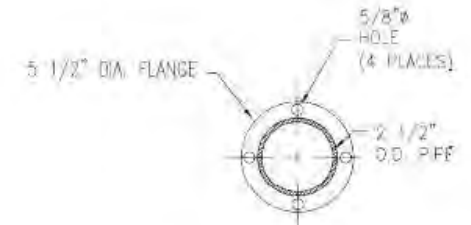
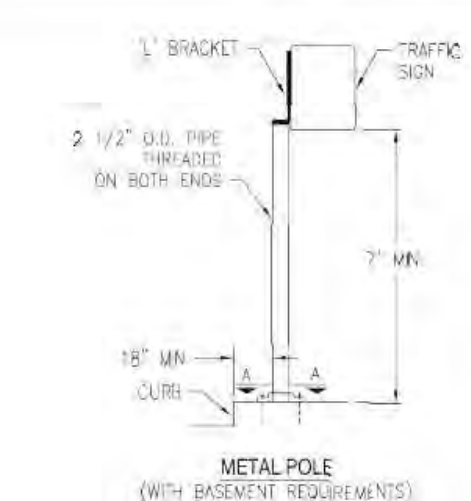

**SECTION A-A**  
5/8" HOLE (4 PLACES)  
2 1/2" O.D. PIPE  
1/4" THICK FLANGE  
USE 3/8" DIA. X 3" LENGTH ANCHOR BOLTS - ALL 4 PLACES OR EQUAL

CITY OF OAKLAND DESIGN AND CONSTRUCTION SERVICES DEPARTMENT



SIGN INSTALLATION  
DETAILS

TRANSPORTATION SERVICES MANAGER
DATE: JANUARY 2020
REV: 04/20
T-5

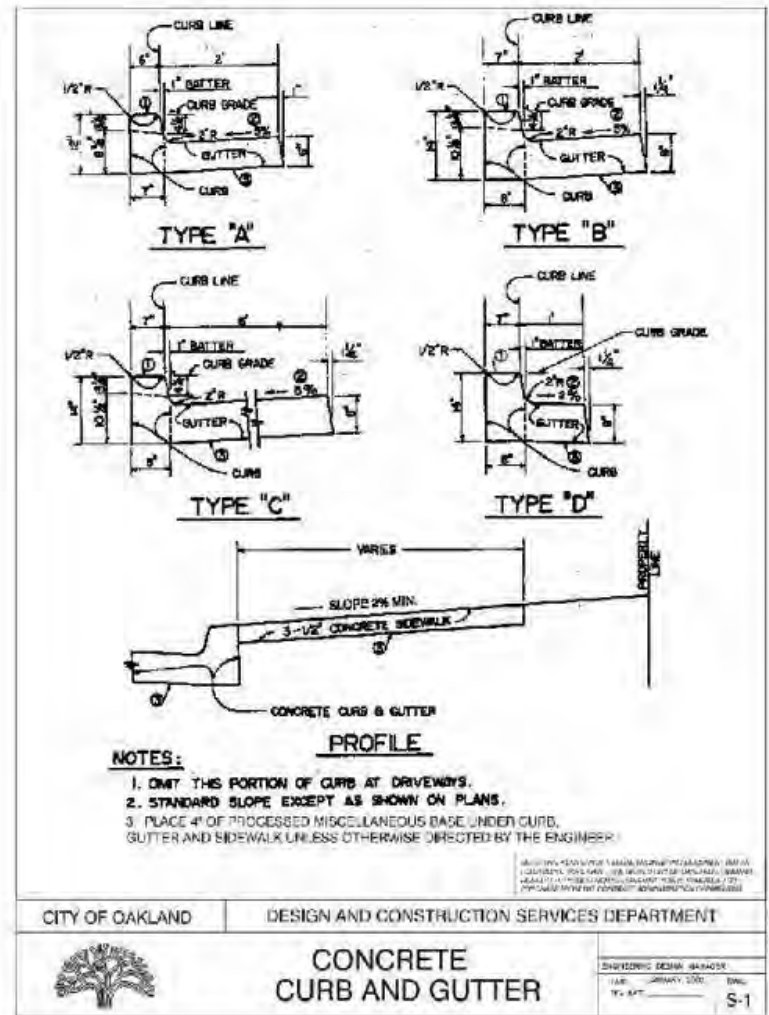

CITY OF OAKLAND	DESIGN AND CONSTRUCTION SERVICES DEPARTMENT
<b>CONCRETE CURB AND GUTTER</b>	
ENGINEERING DESIGN MANAGER	DATE: JANUARY 2020 DWG: S-1

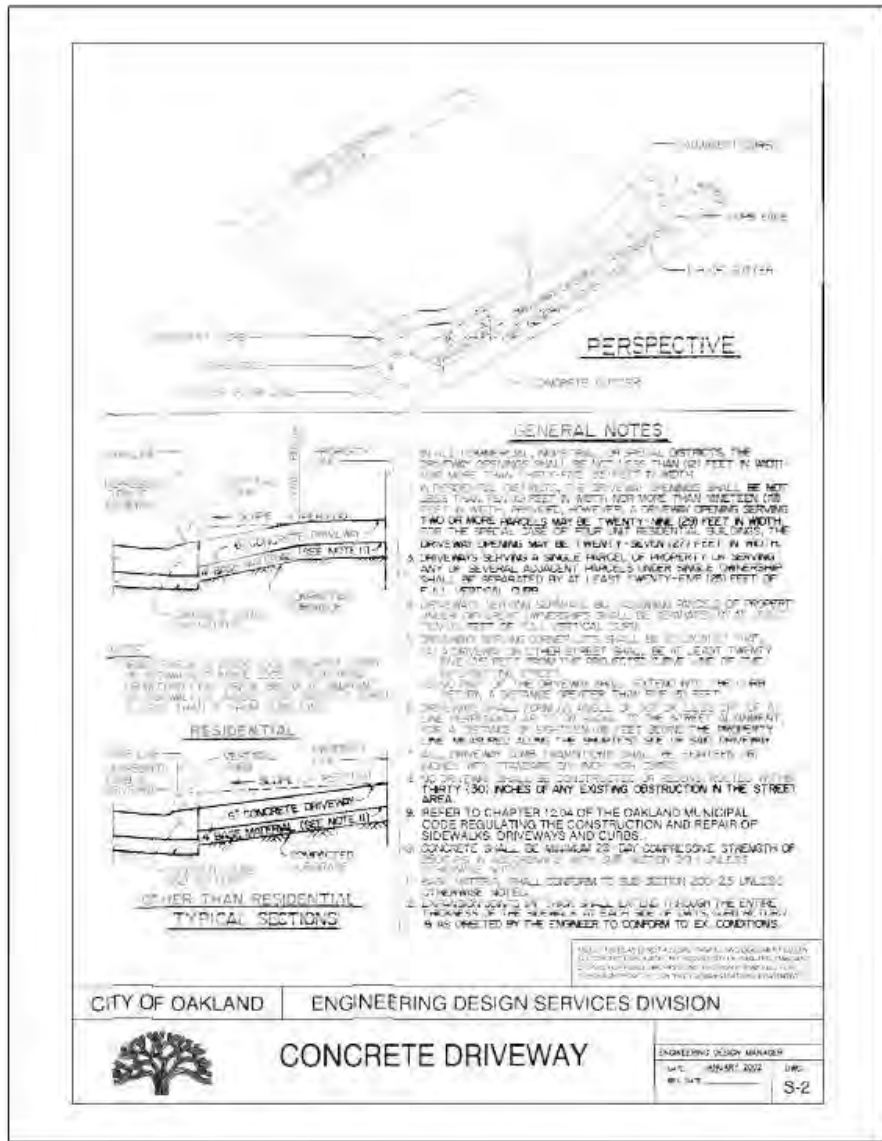

CITY OF OAKLAND	ENGINEERING DESIGN SERVICES DIVISION
<b>CONCRETE DRIVEWAY</b>	
ENGINEERING DESIGN MANAGER	DATE: JANUARY 2020 DWG: S-2

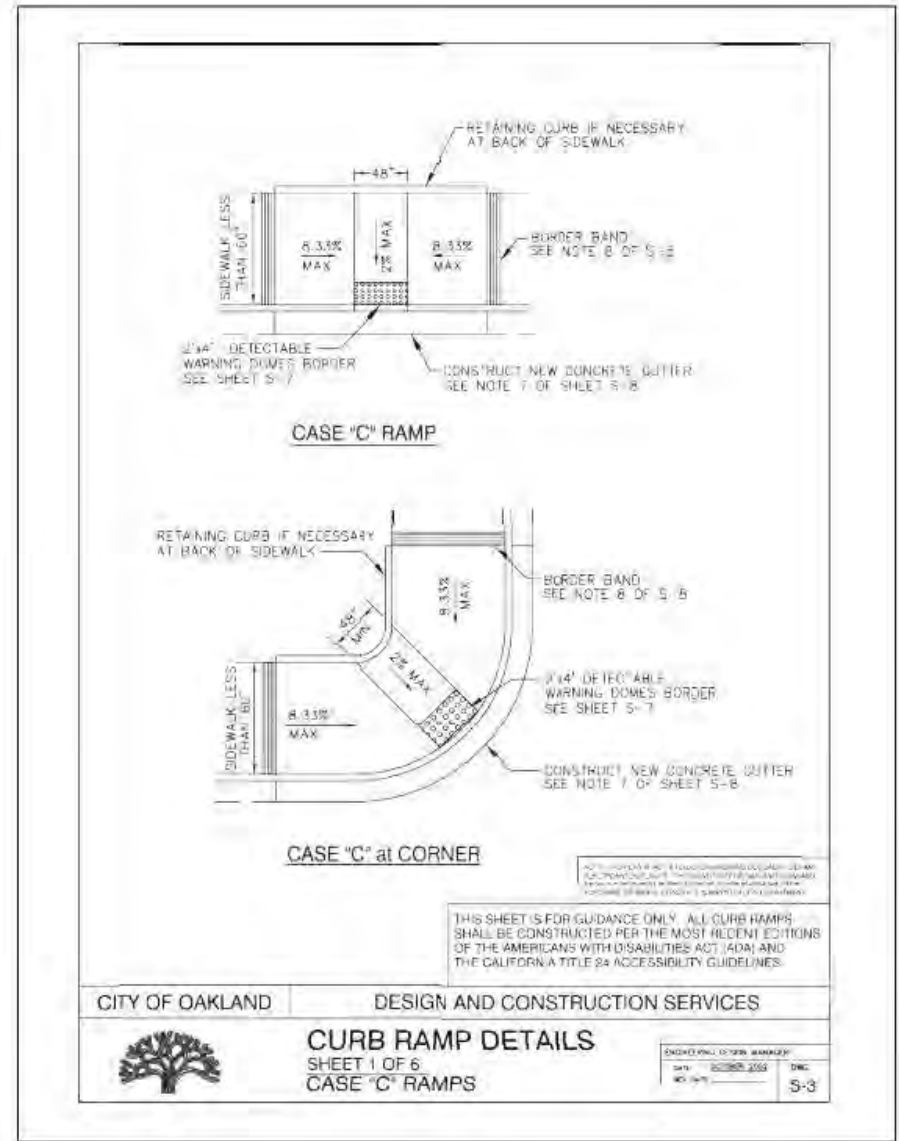

CITY OF OAKLAND	DESIGN AND CONSTRUCTION SERVICES
<b>CURB RAMP DETAILS</b>	
ENGINEERING DESIGN MANAGER	DATE: OCTOBER 2019 DWG: S-3

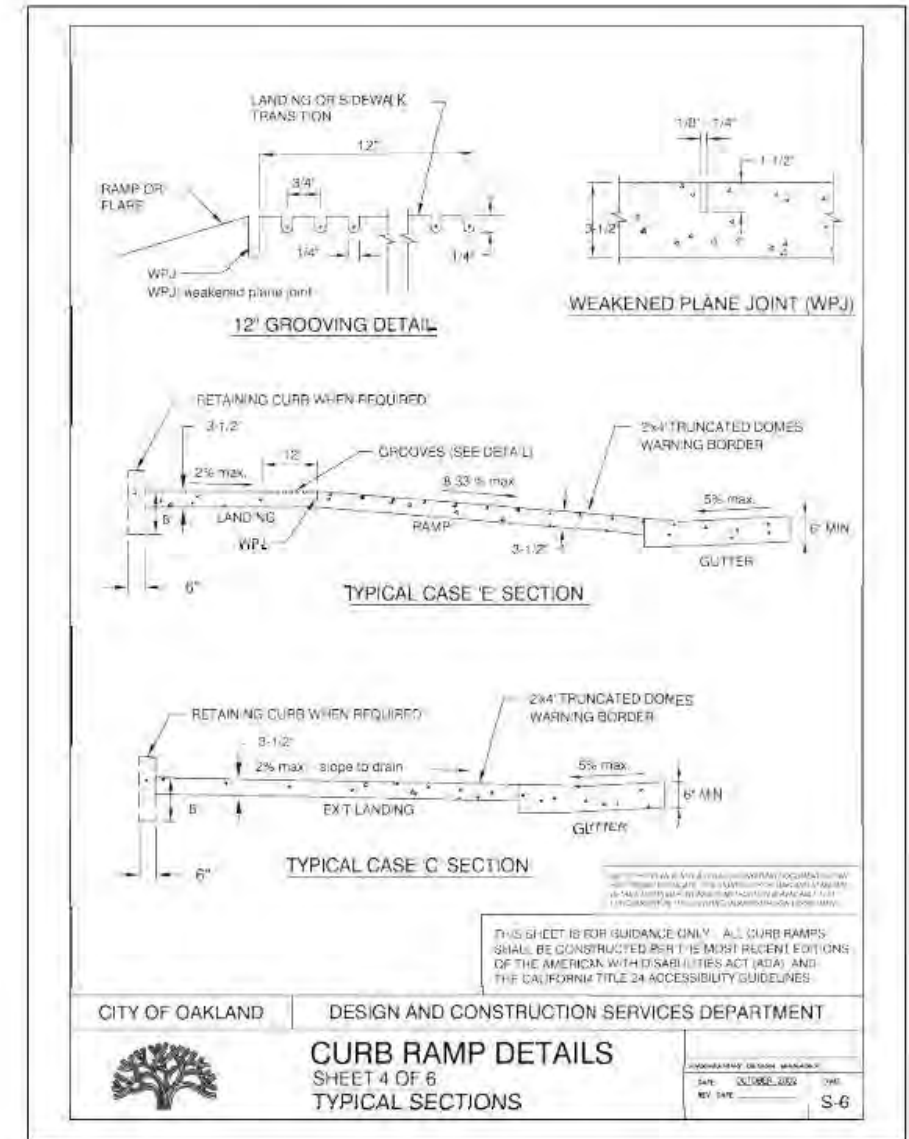
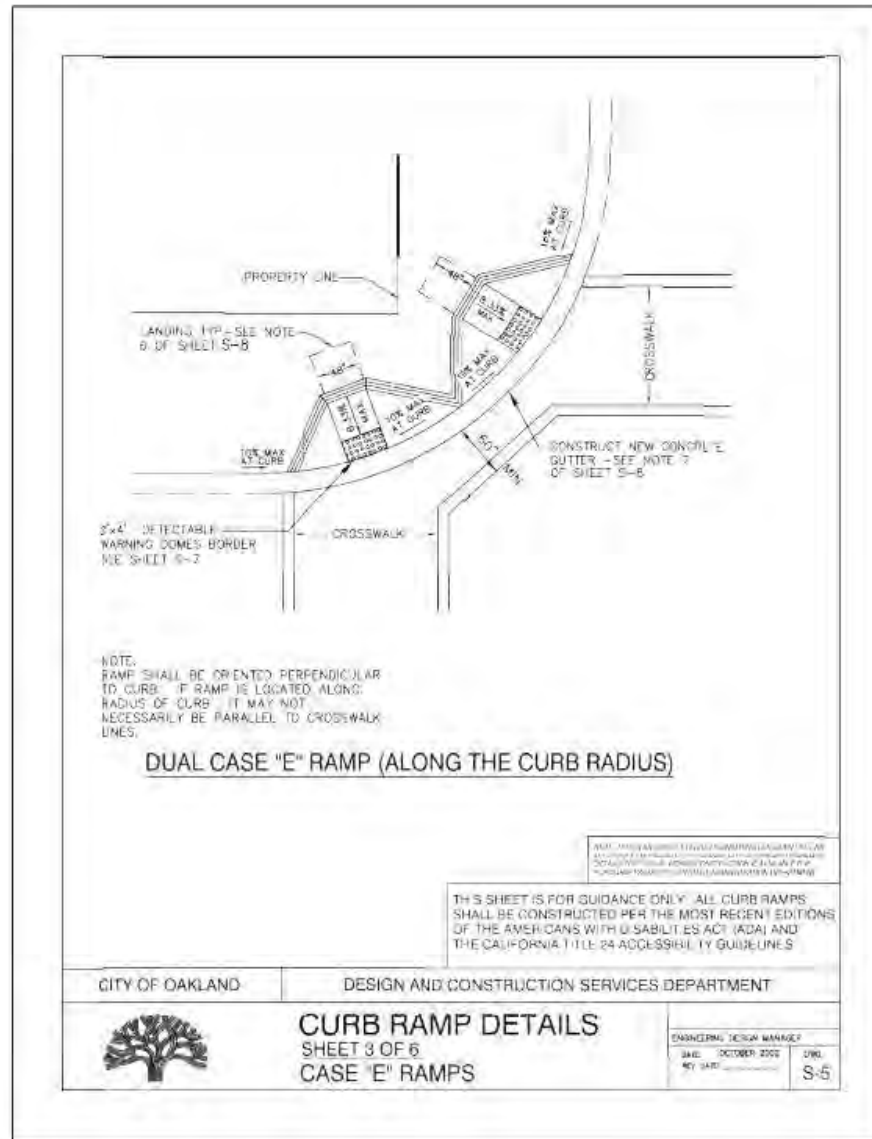
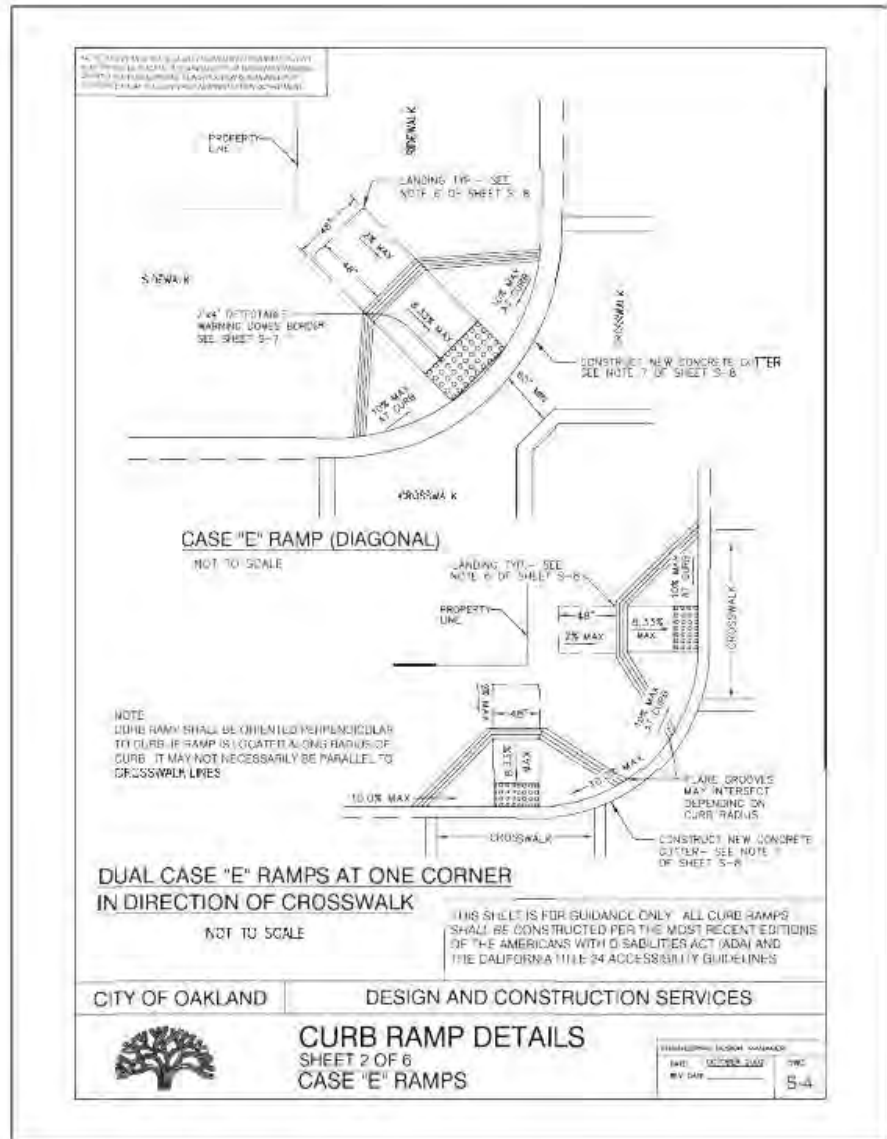

1. Curb ramps shall have 4 ft. by 2 ft. long detectable warning border centered and squared at the ramp bottom.
2. The detectable warning border shall contrast visually with the adjoining surfaces, either light or dark. The material used to provide contrast shall be an integral part of the walking surface and shall contrast by at least 70 percent. A fully cured 2 ft. x 2 ft. sample of both the cast-in-place detectable warning border and the adjacent curb ramp shall be submitted to the Engineer for review and approval prior to installation.
3. Dome orientation shall conform to the latest ADA / Title 24 regulations.
4. The closest corner of the truncated dome tile to the street shall be set 6" from the flowline.
5. Detectable dome warning tiles or strips made of materials other than concrete shall only be used with the written approval of the Director of Public Works.
6. Precast concrete detectable warning dome pavers shall be installed on top of a 4 inch thick concrete pad. Mortared joints shall be flush with top surface and finished to provide a smooth surface. Pavers shall be laid such that joints are level with adjoining joints to provide a smooth transition from paver to paver and from paver to concrete surface.

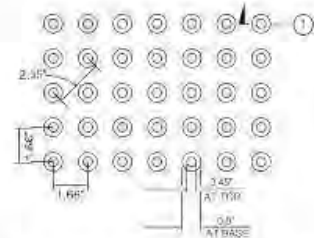

Bottom Diameter = 0.9 inches  
 Top Diameter = 0.4 inches  
 Height = 0.2 inches  
 Center-to-Center Spacing = 2.35 inches

PLAN VIEW OF DETECTABLE WARNING DOMES  
 NTS

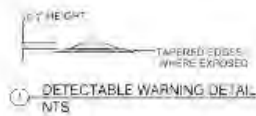

THIS SHEET IS FOR GUIDANCE ONLY. ALL CURB RAMPS SHALL BE CONSTRUCTED FOR THE MOST RECENT EDITIONS OF THE AMERICAN WITH DISABILITIES ACT (ADA), AND THE CALIFORNIA TITLE 24 ACCESSIBILITY GUIDELINES.

CITY OF OAKLAND	DESIGN AND CONSTRUCTION SERVICES
	<b>CURB RAMP DETAILS</b> SHEET 5 OF 6 DETECTABLE WARNINGS
ENGINEERING DESIGN MANAGER REV. DATE: OCTOBER 2012	CHK: S-7

**CASE "C" CURB RAMP NOTES**

1. If site conditions do not accommodate a Case E ramp, a Case "C" Curb Ramp shall be constructed.
2. If the sidewalk is less than 5-feet wide, a Case C ramp shall be installed.
3. The maximum slope of the lower landing of a Case C ramp shall be 2%. In all cases the lower landing shall be sloped to drain.
4. No vertical obstructions shall be allowed within a Case C curb ramp.

**CASE "E" CURB RAMP NOTES:**

5. Two ramps shall be provided at each corner of an intersection, unless otherwise allowed by the plans or by the Engineer. The centerline and path of travel of both curb ramps must be perpendicular to the gutter.
6. A level landing (4-ft deep with 2% max. slope) shall be provided at the upper end of each Case E curb ramp over its full width to permit safe exit from the ramp surface. If a level landing cannot be installed, then the side flares of the ramp shall slope less than or equal to 8.33%.

**GENERAL CURB RAMP NOTES:**

7. When constructing curb ramps, construct concrete gutter to match existing gutter widths. The new gutter shall be flush with the bottom of the curb ramp and the new gutter shall be considered part of the curb ramp construction.
8. Each curb ramp shall be bounded by a 12-inch border band with 1/4 inch deep grooves scored 3/4 inches apart except in the curb and gutter area.
9. Vertical obstructions, such as utility poles and traffic signals, shall only be allowed with the approval of the Engineer.
10. Existing utility boxes and covers shall be adjusted to conform flush with the curb ramp surface. All utility boxes and covers located within the detectable warning border area shall be relocated.

CITY OF OAKLAND	ENGINEERING DESIGN DIVISION
	<b>CURB RAMP DETAILS</b> SHEET 6 OF 6 GENERAL NOTES
ENGINEERING DESIGN MANAGER DATE: OCTOBER 2012	CHK: S-8

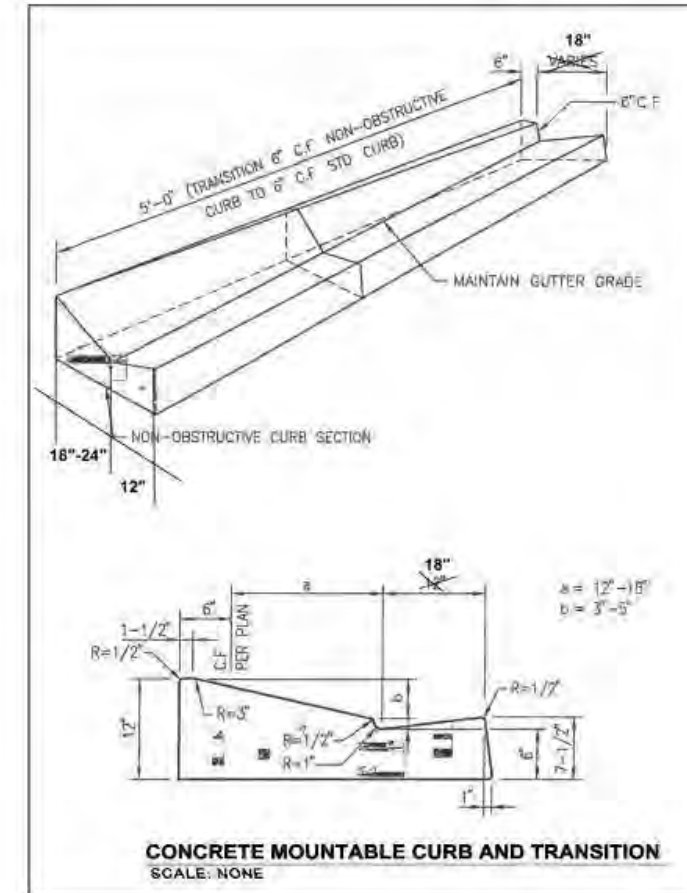

**CONCRETE MOUNTABLE CURB AND TRANSITION**  
 SCALE: NONE

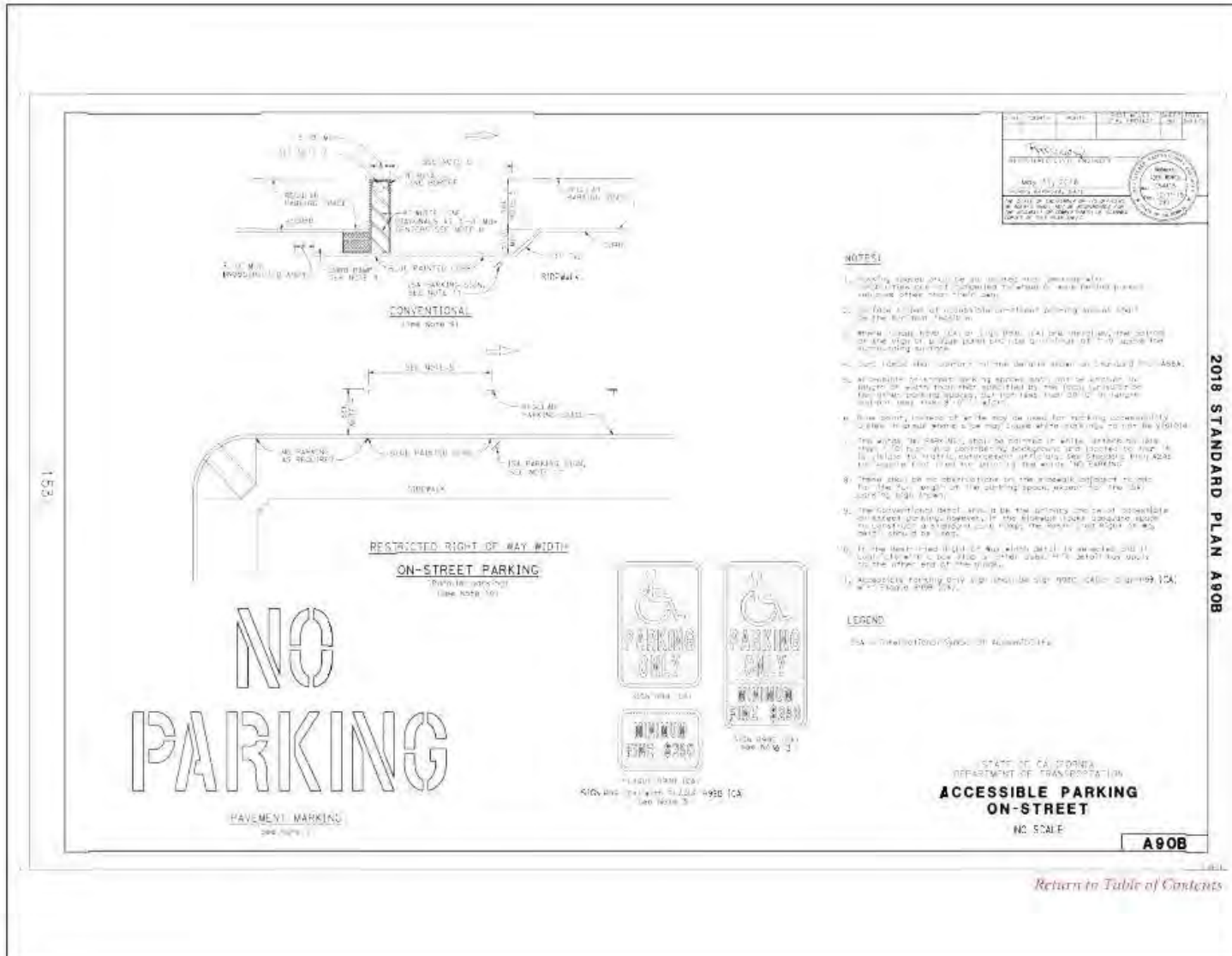

[Return to Table of Contents](#)

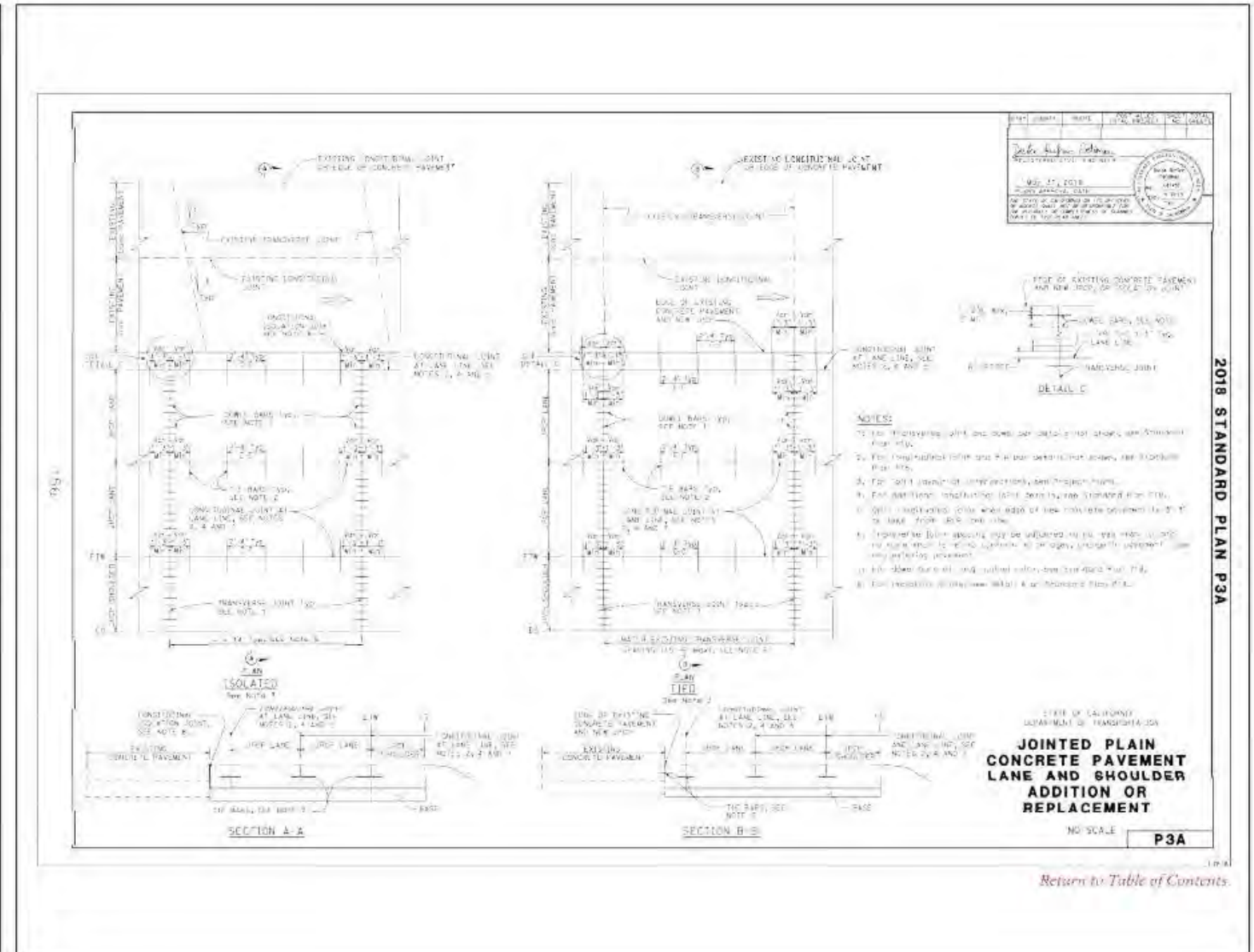

[Return to Table of Contents](#)



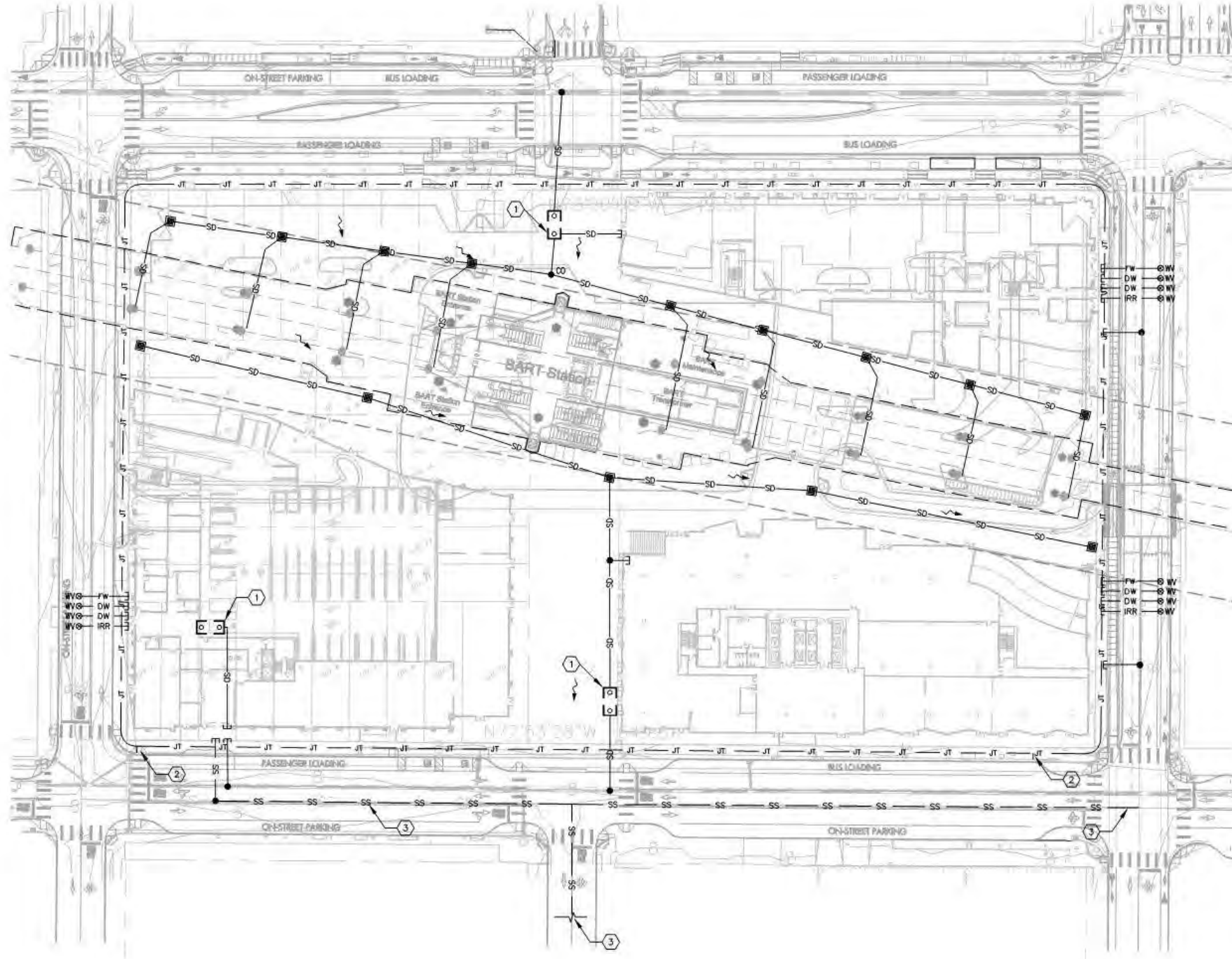

**UTILITY KEYNOTES:**

- ① NEW OLD CASTLE WASHINGTON GULD PV-V-8-WA-0001 PERK FILTER OR APPROVED EQUAL SEE DETAIL ON SHEET C3.01
- ② POTENTIAL CONNECTION LOCATION FOR ELECTRICAL AND TELECOM
- ③ REBUILD/UPSIZE SANITARY SEWER LINE TO CONNECTION AT CENTER ST x 3RD ST

**UTILITY LEGEND:**

- SD STORM DRAIN LINE
- IRR IRRIGATION LINE
- FW FIRE WATER LINE
- DW DOMESTIC WATER LINE
- SS SANITARY SEWER LINE
- JT JOINT TRENCH: ELEC + TELECOM
- DOMESTIC WATER MANHOLE PER CITY OF OAKLAND STANDARD DETAIL D-11
- STORM DRAIN MANHOLE
- WV WATER VALVE
- DRAIN INLET

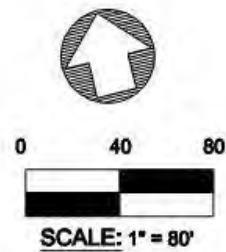

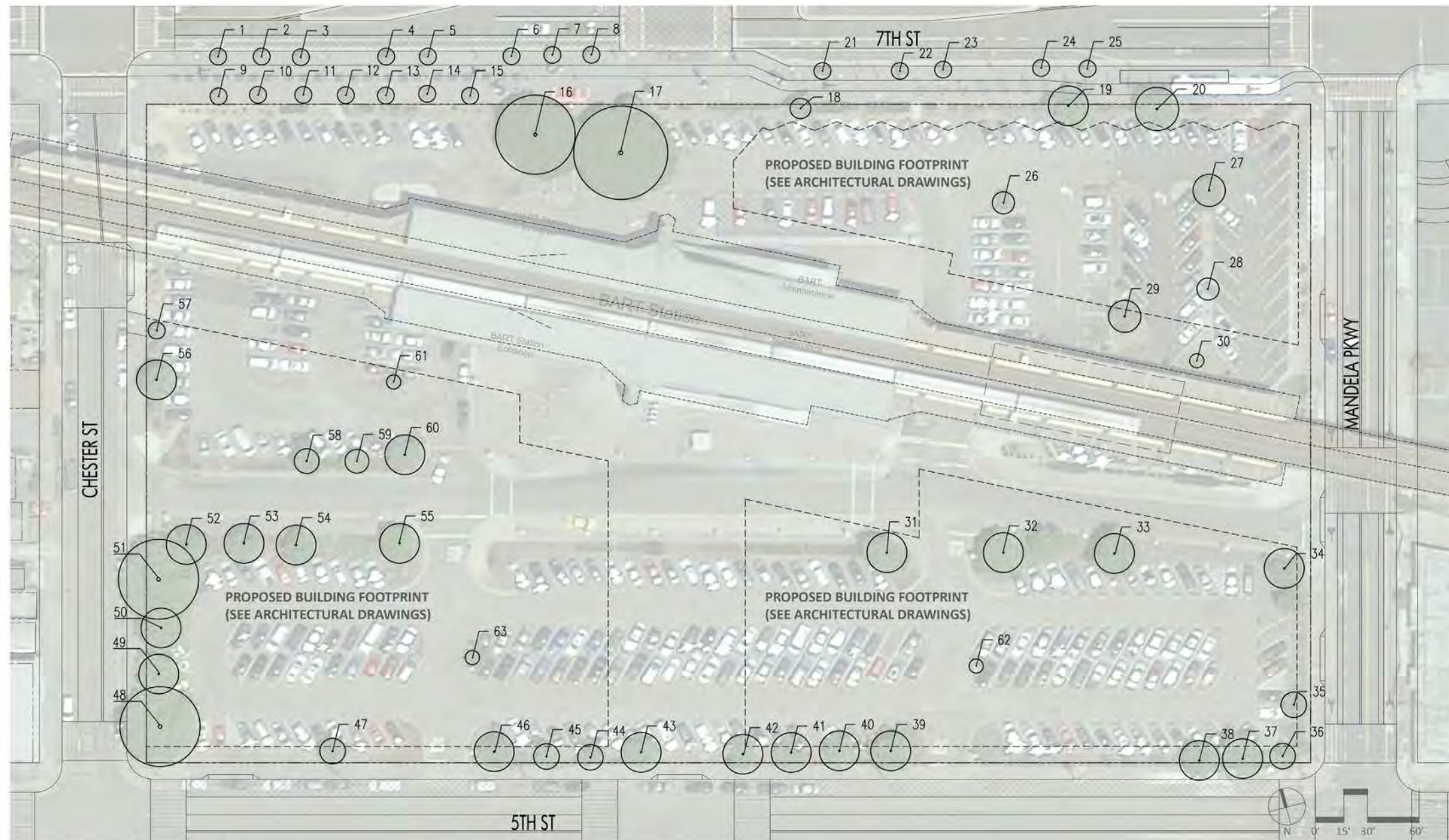

**Trees Proposed for Removal**

Key	Species	DBH (in)
1	Pistacia chinensis	4
2	Pistacia chinensis	4
3	Pistacia chinensis	4
4	Pistacia chinensis	3
5	Pistacia chinensis	5
6	Pistacia chinensis	4
7	Pistacia chinensis	4
8	Pistacia chinensis	4
9	Pistacia chinensis	4
10	Pistacia chinensis	4
11	Pistacia chinensis	4
12	Pistacia chinensis	4
13	Pistacia chinensis	4

Key	Species	DBH (in)
14	Pistacia chinensis	4
15	Pistacia chinensis	4
16	Pinus pinea	36
17	Pinus pinea	32
18	Liriodendron tulipifera	9
19	Liriodendron tulipifera	11
20	Liriodendron tulipifera	13
21	Pistacia chinensis	4
22	Pistacia chinensis	4
23	Pistacia chinensis	4
24	Pistacia chinensis	4
25	Pistacia chinensis	5
26	Maytenus boaria	7

Key	Species	DBH (in)
27	Maytenus boaria	12
28	Maytenus boaria	5
29	Maytenus boaria	16
30	Maytenus boaria	2
31	Liriodendron tulipifera	13
32	Liriodendron tulipifera	11
33	Liriodendron tulipifera	13
34	Liriodendron tulipifera	11
35	Liriodendron tulipifera	9
36	Liriodendron tulipifera	12
37	Liriodendron tulipifera	11
38	Liriodendron tulipifera	10
39	Liriodendron tulipifera	11

Key	Species	DBH (in)
40	Liriodendron tulipifera	9
41	Liriodendron tulipifera	10
42	Liriodendron tulipifera	10
43	Liriodendron tulipifera	9
44	Liriodendron tulipifera	7
45	Liriodendron tulipifera	8
46	Liriodendron tulipifera	8
47	Liriodendron tulipifera	9
48	Platanus X acerifolia	18
49	Platanus X acerifolia	10
50	Platanus X acerifolia	10
51	Platanus X acerifolia	17
52	Liriodendron tulipifera	12

Key	Species	DBH (in)
53	Liriodendron tulipifera	8
54	Liriodendron tulipifera	8
55	Liriodendron tulipifera	9
56	Liriodendron tulipifera	10
57	Liriodendron tulipifera	5
58	Liriodendron tulipifera	8
59	Liriodendron tulipifera	7
60	Liriodendron tulipifera	9
61	Maytenus boaria	5
62	Maytenus boaria	5
63	Maytenus boaria	7

**Bolded trees are protected trees.**

OWNER



BUILDING T1  
FDP PACKAGE

PROJECT

**WEST OAKLAND BART**  
1451 7th St, Oakland, CA 94607

ARCHITECT



PROJECT TEAM



STAMP

KEY

PROJ #: 168-153 WO BART  
DATE: 06/04/20  
SCALE: 1"=60' - 0"

TITLE:  
**TREE  
REMOVAL  
PLAN**

SHEET:  
**L1.00**

OWNER  
 HENSEL PHELPS  
 suda  
 BUILDING T1 FDP PACKAGE  
 PROJECT  
 WEST OAKLAND BART  
 1451 7th St, Oakland, CA 94607  
 ARCHITECT  
 jrdv ARCHITECTS  
 PROJECT TEAM  
 BKF ENGINEERS  
 1646 N. CALIFORNIA  
 BLVD, SUITE 400  
 WALNUT CREEK  
 CA 94598  
 (925) 940-2200  
 PGAdesign  
 444 17th Street  
 Oakland  
 CA 94612  
 (510) 465-1284  
 stok  
 STOK  
 845B Front Street  
 San Francisco  
 CA 94111  
 (415) 328-7100  
 STAMP  
 KEY  
 PROJ #: 168-153 WO BART  
 DATE: 03/26/20  
 SCALE: 1"=60' - 0"  
 TITLE: LAYOUT & MATERIALS PLAN  
 SHEET: L1.01

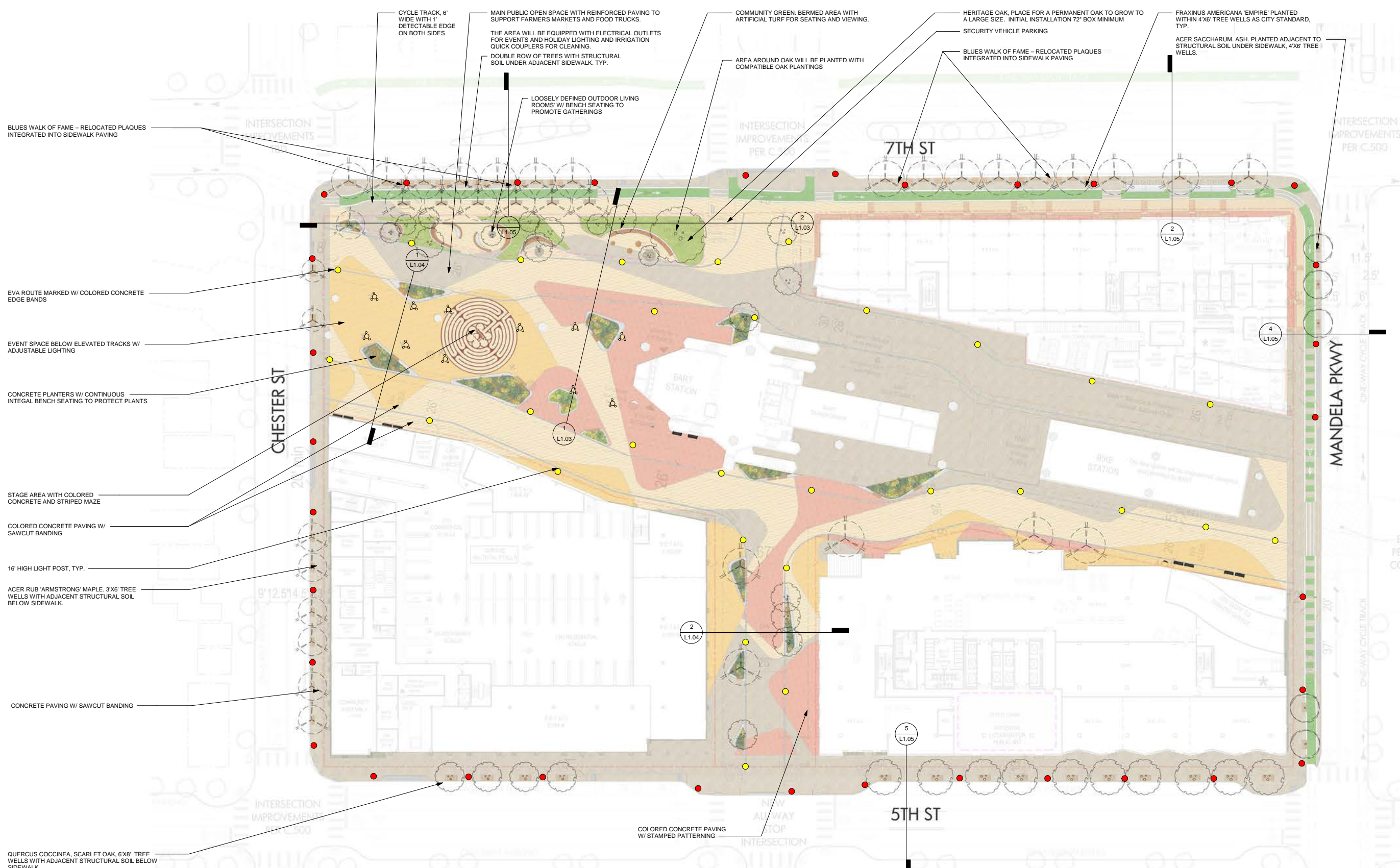

**IRRIGATION METHOD & WATER EFFICIENT LANDSCAPE ORDINANCE**

- IRRIGATION SYSTEM WILL BE DESIGNED TO PROVIDE THE MINIMUM AMOUNT OF WATER NECESSARY TO SUSTAIN GOOD PLANT HEALTH. ALL SELECTED COMPONENTS TO BE COMMERCIAL GRADE, SELECTED FOR DURABILITY, VANDAL RESISTANCE AND MINIMUM MAINTENANCE REQUIREMENT.
- THE SYSTEM WILL BE DRIPLINE IRRIGATION AS APPROPRIATE TO PLANT TYPE, EXPOSURE AND SLOPE CONDITIONS.
- CONTROL OF THE SYSTEM WILL BE VIA A WEATHER-ENABLED CONTROLLER CAPABLE OF DAILY SELF-ADJUSTMENT BASED ON REAL-TIME WEATHER CONDITIONS AS MEASURED BY AN ON-SITE WEATHER SENSOR.
- THE SYSTEM WILL INCLUDE A MASTER CONTROL VALVE AND FLOW SENSING CAPABILITY WHICH WILL SHUT DOWN ALL OR PART OF THE SYSTEM IF LEAKS ARE DETECTED.
- THE LANDSCAPE IS OVER 500 SQUARE FEET OF NEW LANDSCAPING AND WILL THEREFORE MEET THE REQUIREMENTS OF THE WATER EFFICIENCY LANDSCAPE ORDINANCE (WELO): [HTTPS://WATER.CA.GOV/LEGACYFILES/WATERUSEEFFICIENCY/LANDSCAPEORDINANCE/DOCS/TITLE%202023%20EXTRACT%20-%20OFFICIAL%20CCR%20PAGES.PDF](https://water.ca.gov/legacyfiles/wateruseefficiency/landscapeordinance/docs/title%202023%20extract%20-%20official%20ccr%20pages.pdf)

**WEST OAKLAND STATION CRIME PREVENTION THROUGH ENVIRONMENTAL DESIGN STRATEGIES**

- AREA LIGHTING:**
- ALL LOADING, UNLOADING, KISS AND RIDE, DROP OFF, PICK UP AREAS WILL BE LIT TO 5 CANDLE FOOT. SIDEWALKS AROUND THE SITE WILL BE LIT TO 1.25 CANDLE FOOT (CITY STANDARD), BIKE LOCKER AREAS WILL BE LIT TO 10 CANDLE FOOT, AND EXTERIOR PATRON WAITING AREAS OUTSIDE THE BART FAIR GATES WILL BE LIT TO 10 CANDLE FOOT. SEE SHEET L1.07 FOR MORE DETAIL REGARDING THE LOCATION OF THESE AREAS.
  - POLE LIGHTS ARE KEPT 20' CLEAR OF TREES AND LANDSCAPING. LIGHT POLES ARE LESS THAN 22' HIGH. OTHER LIGHTS WILL BE MOUNTED ON BUILDING, ON BOLLARDS OR ALONG OVERHEAD WIRES (<20' HIGH).
  - THE LIGHTING WILL USE A FULL COLOR INDEX IN ORDER TO BETTER DISTINGUISH FORM AND MOVEMENT.
- AREA PLANTING:**
- PLANTINGS, INCLUDING THE RAISED PLANTERS AND BERMS THEY ARE IN, WILL NOT EXCEED 36" IN HEIGHT. TREES WILL BE LIMBED UP TO 7' HIGH. THE INTENTION IS TO AVOID BLIND SPOTS CAUSED BY HIGH PLANTS AND PLANTERS. TREES WILL BE THE TYPE THAT RETAIN A THIN TRUNK AS THEY GROW AND MATURE. THE TREE CANOPIES WILL NOT BE OVERLY DENSE AND WILL ALLOW LIGHT IN FROM ABOVE.

- AREA SITE FURNISHINGS:**
- SITE FURNISHINGS, EARTH FORMS, AND ARTWORK WILL BE DESIGNED NOT TO OBSCURE VISIBILITY. BENCHES HAVE SEPARATORS/ARMRESTS, SO THEY ARE USED FOR SITTING ONLY. PLANTER BOXES AND LANDSCAPE WALLS WILL HAVE GROOVES OR ELEMENTS TO DETER SKATEBOARDERS. FENCES ARE DESIGNED TO RESIST TEMPERING AND CLIMBING.
- AREA SIGNAGE:**
- DIRECTIONAL AND WAYFINDING SIGNAGE WILL BE PLACED AT APPROPRIATE LOCATIONS TO HELP DIRECT THE VISITOR TO THEIR DESTINATION.
- SURVEILLANCE CAMERAS:**
- A SERIES OF SURVEILLANCE CAMERAS WILL BE PLACED TO COVER THE ENTIRE SITE. THESE CAMERAS WILL COMPLY WITH BART FACILITY STANDARDS.

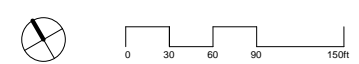

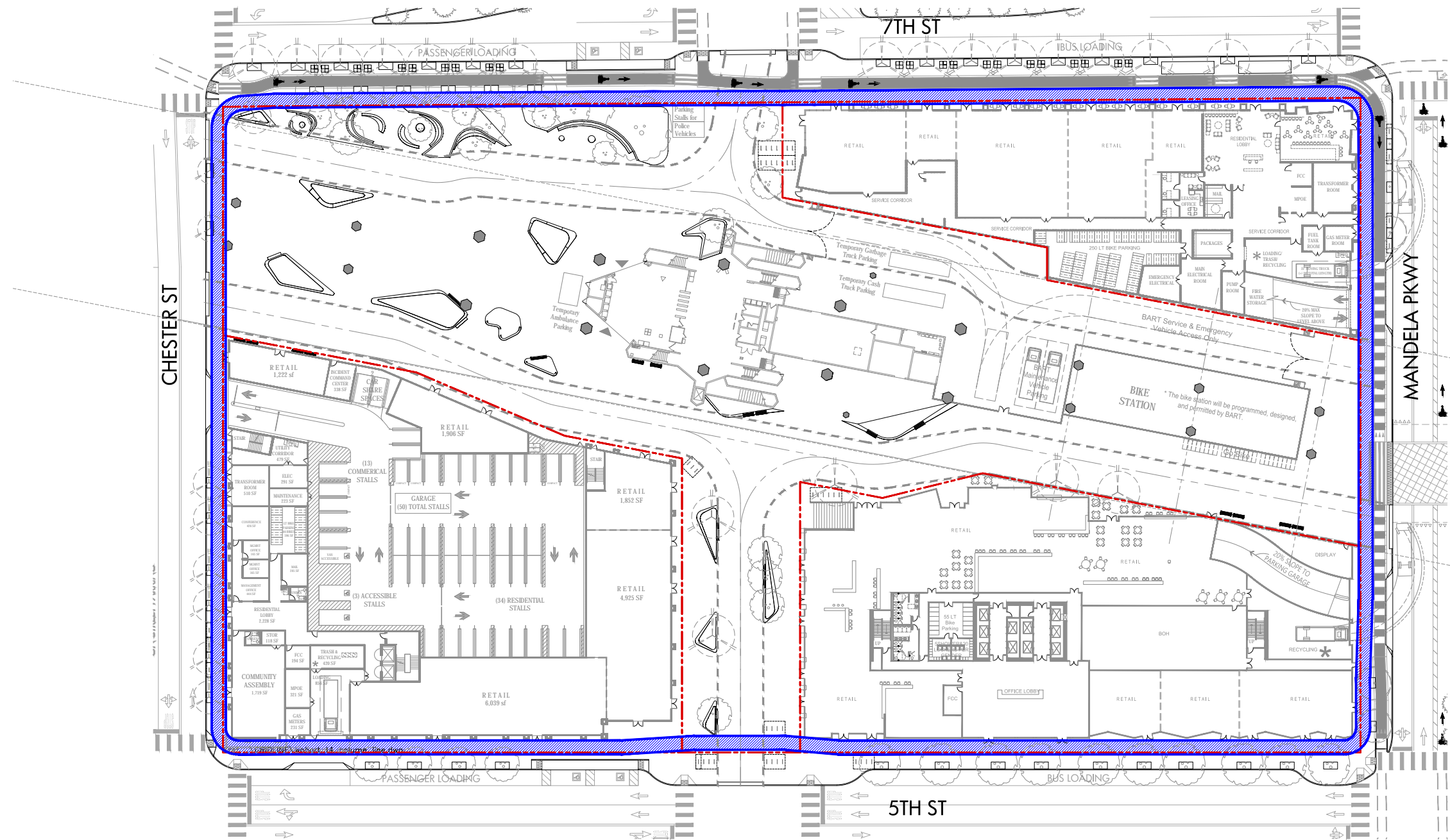

**LEGEND**

- 8' CLEAR ZONE FOR PEDESTRIAN
- PROPERTY LINE

**STAMP**

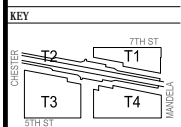

PROJ # 168-153 WO BART  
 DATE July 23, 2020  
 SCALE 1/32"=1'-0"  
 TITLE

PUBLIC ACCESS

SHEET: **L1.01.02**

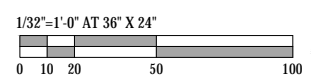

OWNER



BUILDING T1  
FDP PACKAGE

PROJECT

WEST OAKLAND BART  
1451 7th St, Oakland, CA 94607

ARCHITECT



PROJECT TEAM

BNF ENGINEERS  
1508 N CALIFORNIA  
BLVD, SUITE 400  
WALNUT CREEK  
CA 94598  
(925) 940-2200

PGA DESIGN  
444 17th Street  
Oakland  
CA 94612  
(510) 465-1284

STOK  
9408 Front Street  
San Francisco  
CA 94111  
(415) 329-7100

STAMP

KEY

PROJ #: 168-153 WO BART  
DATE: 03/26/20  
SCALE: 1"=60' - 0"

TITLE:  
LANDSCAPE  
WALL HEIGHT  
PLAN

SHEET:  
L1.02

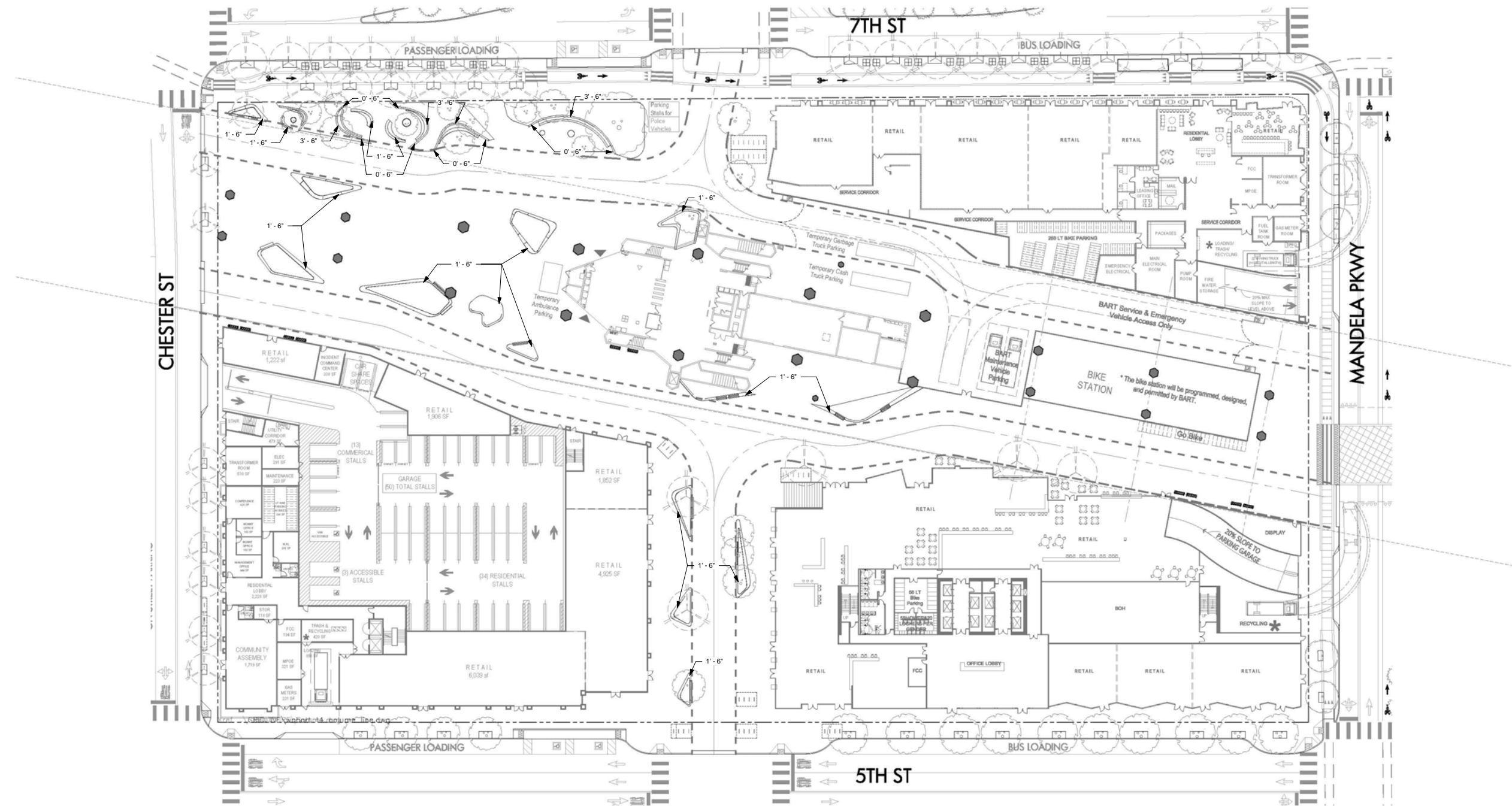



1 SECTION 1  
 L1.03 1/16" = 1'-0"



2 SECTION 2  
 L1.03 1/16" = 1'-0"

STAMP

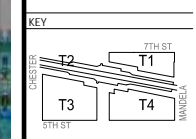

PROJ # 188-151 WO BART  
 DATE July 24, 2020  
 SCALE 1/16" = 1'-0"  
 TITLE

SECTIONS

SHEET: L1.03

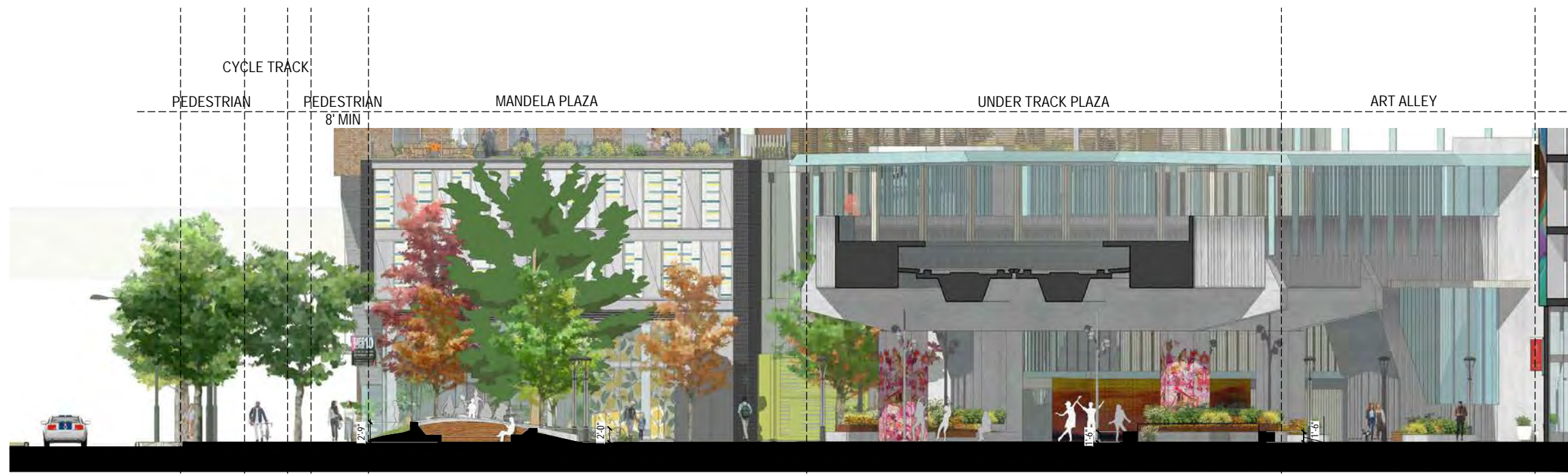

1 SECTION 3  
L1.04 1/16" = 1'-0"

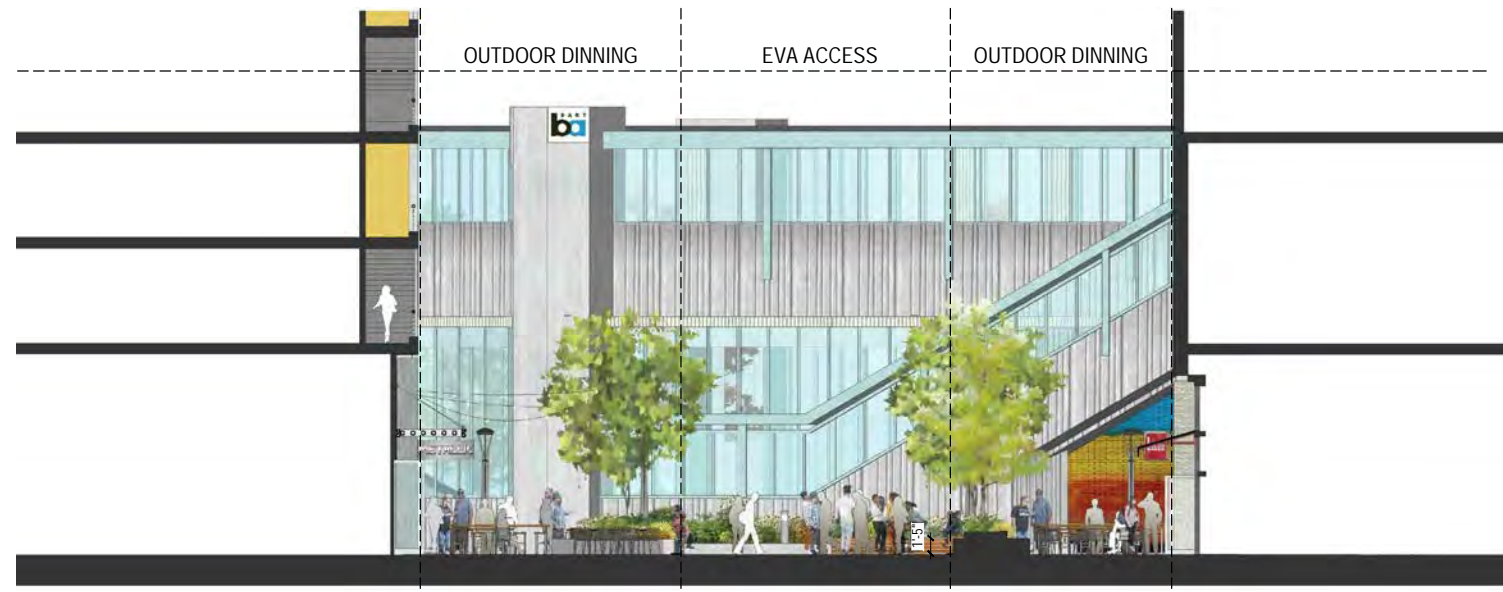

2 SECTION 4  
L1.04 1/16" = 1'-0"



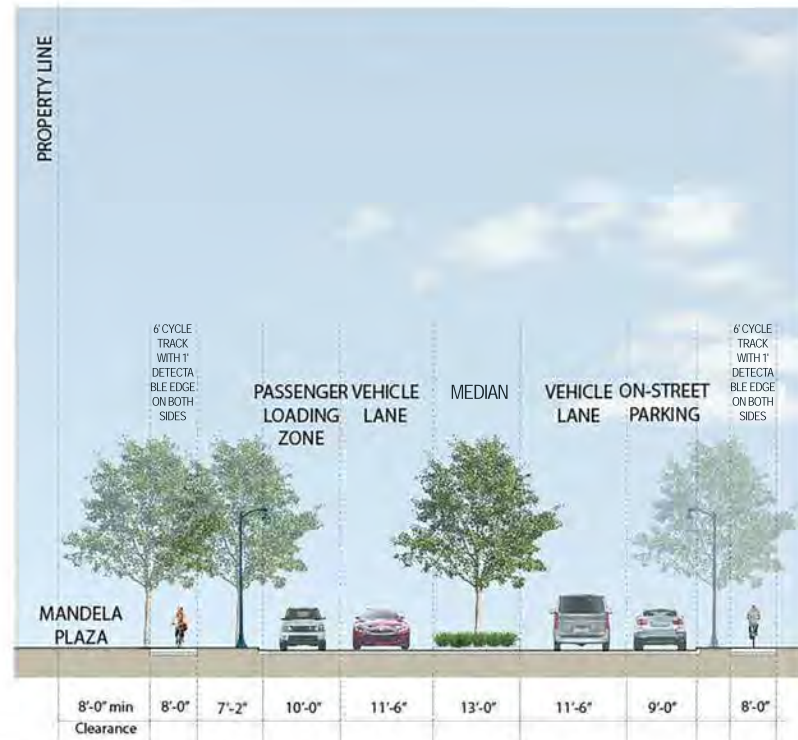

1 7TH STREET WEST SECTION  
L1.05 1" = 20'-0"

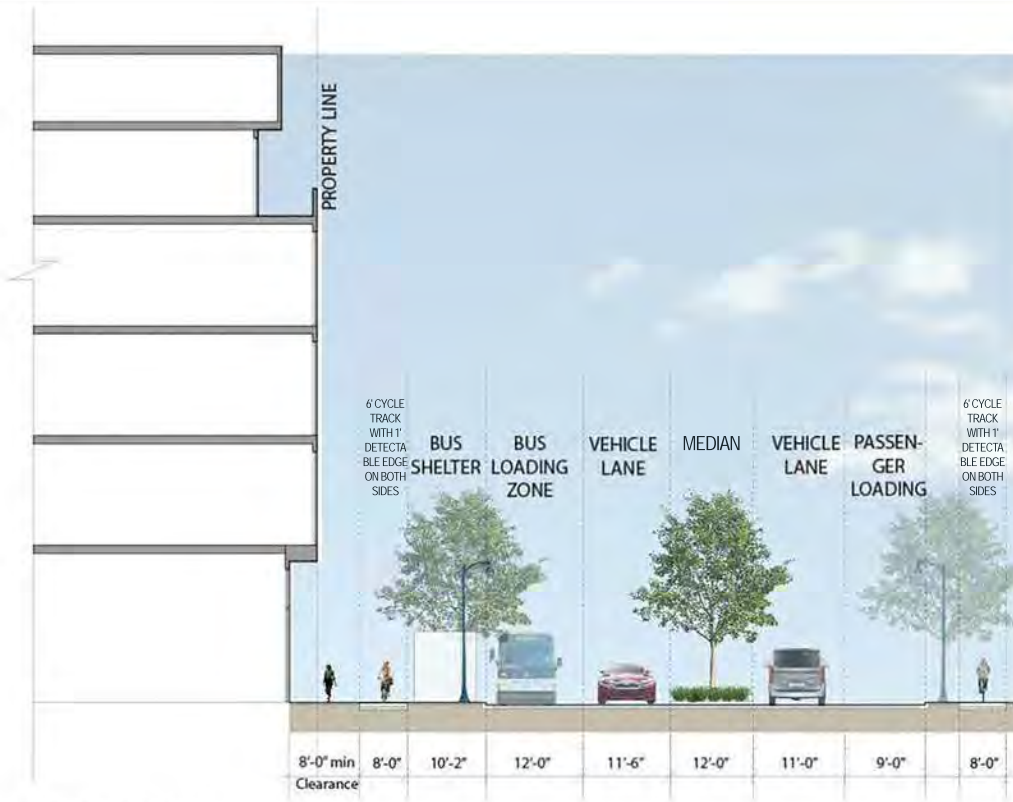

2 7TH STREET EAST SECTION  
L1.05 1" = 20'-0"

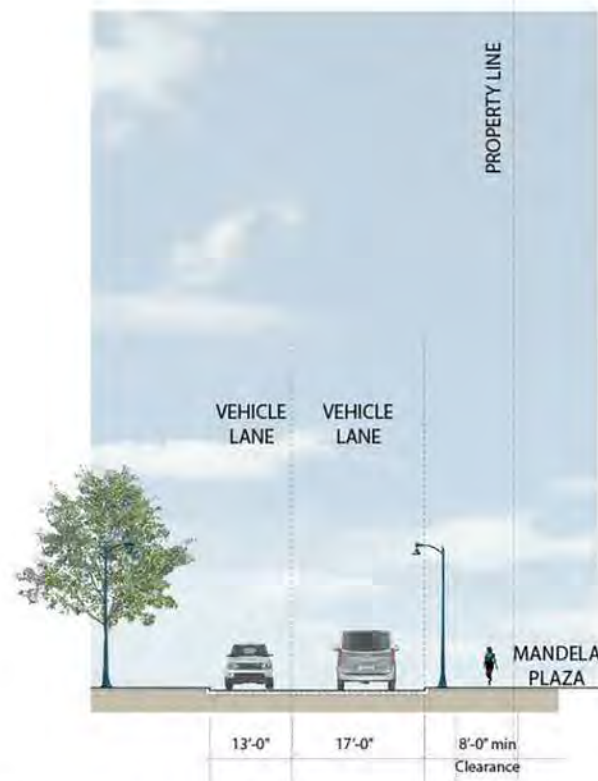

3 CHESTER STREET SECTION  
L1.05 1" = 20'-0"

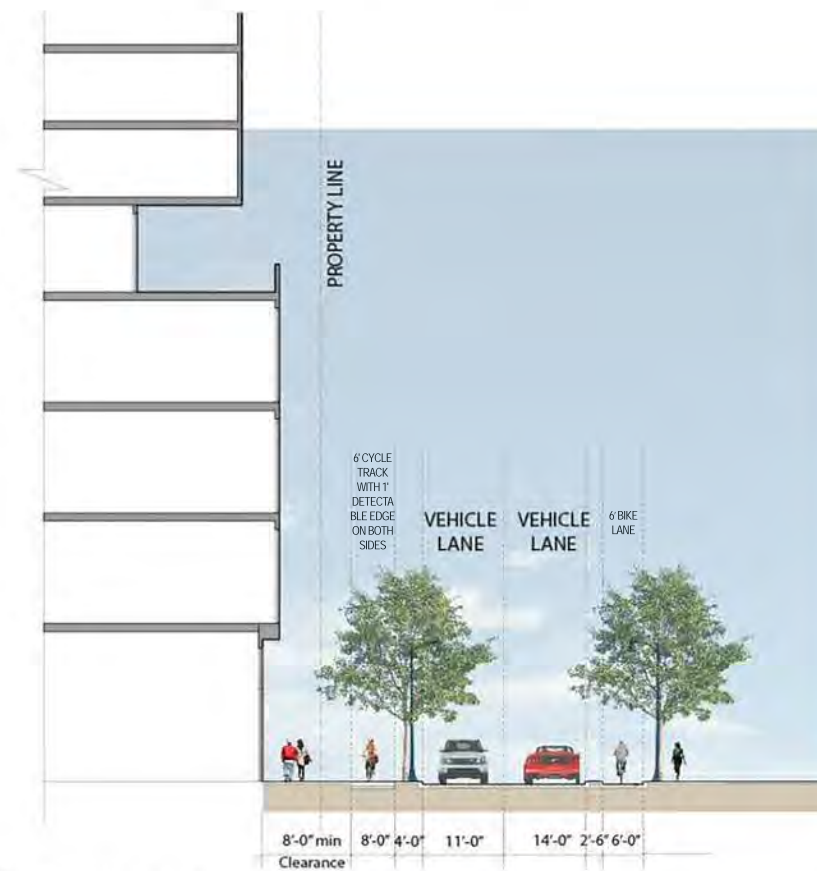

4 MANDELA PKWY SECTION  
L1.05 1" = 20'-0"

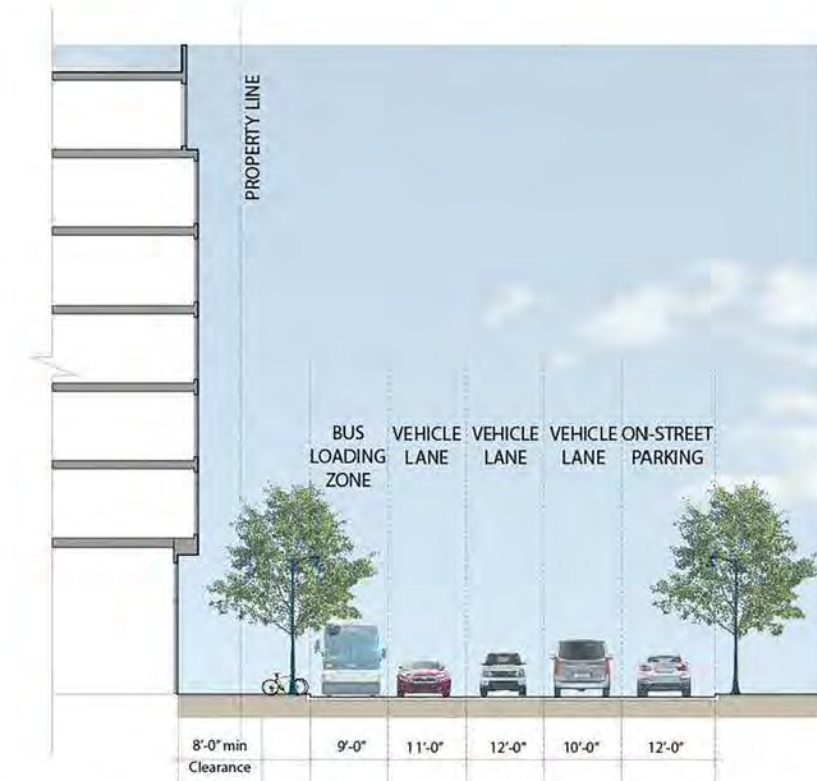

5 5TH STREET SECTION  
L1.05 1" = 20'-0"

OWNER  
 HENSEL PHELPS  
 suda  
 BUILDING T1 FDP PACKAGE  
 PROJECT  
**WEST OAKLAND BART**  
 1451 7th St, Oakland, CA 94607  
 ARCHITECT  
 jrdv ARCHITECTS  
 PROJECT TEAM  
 BIL BOHANNON  
 1000 14TH AVENUE  
 SUITE 400  
 BERKELEY, CA 94710  
 (415) 841-1000  
 BART 100  
 PGAdesign  
 STOK  
 STRIP  
 KEY  
 PROJ # 08-150-000-BART  
 DATE 06-04-20  
 SCALE 1"=20'-0"  
 TITLE **STREET SECTIONS**  
 SHEET **L1.05**



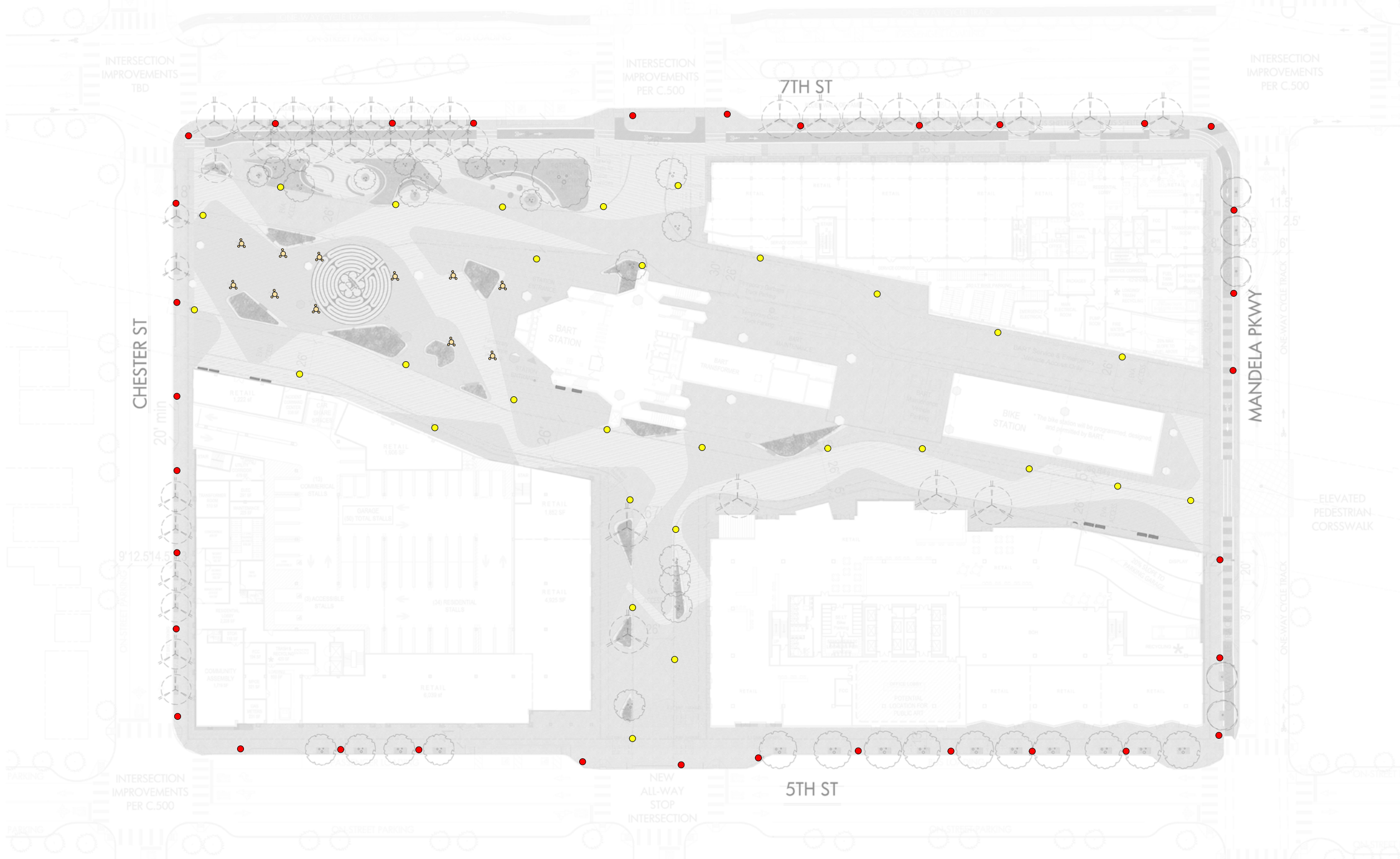

**LEGEND - LIGHTING PLAN**

- AREA LIGHTS FOR PLAZA
- AREA LIGHTS WITH MULTIPLE HEADS FOR EVENT PLAZA
- STREET LIGHTS AS CITY REQUIRED

OWNER	 						
PROJECT	 <b>BUILDING T1</b> <b>FDP PACKAGE</b>						
ARCHITECT	 <b>WEST OAKLAND BART</b> 1451 7th St, Oakland, CA 94607						
PROJECT TEAM	<table style="width: 100%; font-size: 8px;"> <tr> <td style="width: 50%;"> <b>BKF ENGINEERS</b>            1546 N. CALIFORNIA BLVD., SUITE 400            WALNUT CREEK, CA 94596            (925) 940-2200         </td> <td style="width: 50%; text-align: right;"> </td> </tr> <tr> <td> <b>PGA DESIGN</b>            444 17th Street            Oakland, CA 94612            (510) 465-1284         </td> <td style="text-align: right;"> </td> </tr> <tr> <td> <b>STOK</b>            945B Front Street            San Francisco, CA 94111            (415) 329-7100         </td> <td style="text-align: right;"> </td> </tr> </table>	<b>BKF ENGINEERS</b> 1546 N. CALIFORNIA BLVD., SUITE 400 WALNUT CREEK, CA 94596 (925) 940-2200		<b>PGA DESIGN</b> 444 17th Street Oakland, CA 94612 (510) 465-1284		<b>STOK</b> 945B Front Street San Francisco, CA 94111 (415) 329-7100	
<b>BKF ENGINEERS</b> 1546 N. CALIFORNIA BLVD., SUITE 400 WALNUT CREEK, CA 94596 (925) 940-2200							
<b>PGA DESIGN</b> 444 17th Street Oakland, CA 94612 (510) 465-1284							
<b>STOK</b> 945B Front Street San Francisco, CA 94111 (415) 329-7100							
STAMP							
KEY							
PROJ #:	168-153 WO BART						
DATE:	03/26/20						
SCALE:	1"=60' - 0"						
TITLE:	<b>LIGHTING PLAN</b>						
SHEET:	<b>L1.06</b>						



**PLANTING LEGEND**

- |   |  |   |
|---|--|---|
| <p><b>PLANTING ZONE 1: MANDELA PLAZA ENTRY</b></p> <ul style="list-style-type: none"> <li>CAREX DIVULSA</li> <li>NANDINA DOMESTICA ALBA 'LEMON-LIME'</li> <li>BERBERIS 'ORANGE ROCKET'</li> <li>IRIS DOUGLASIANA 'CANYON SNOW'</li> <li>MUHLENBERGIA DUBIA 'PINE MUHLY'</li> <li>PITTOSPORUM TOBIRA 'MOJO'</li> <li>PHORMIUM 'YELLOW WAVE'</li> <li>CORDYLINE 'DESIGN-A-LINE'</li> <li>DIGIPLIXIS ILLUMINATION 'APRICOT'</li> </ul> | <p><b>PLANTING ZONE 2: SHADE TOLERANT PLANTS BELOW BART TRACKS</b></p> <ul style="list-style-type: none"> <li>MAHONIA 'SOFT CARESS'</li> <li>MUHLENBERGIA DUBIA 'PINE MUHLY'</li> <li>BLECHNUM SPICANT 'DEER FERN'</li> <li>HELLEBORUS ARGUTIFOLIUS</li> <li>WOODWARDIA FIMBRIATA 'GIANT CHAIN FERN'</li> <li>CORDYLINE 'DESIGN-A-LINE'</li> <li>EUPHORBIA CHARACIAS SSP.</li> <li>PHORMIUM 'YELLOW WAVE'</li> </ul> | <p><b>PLANTING ZONE 3: SOUTH FACING ALLEY</b></p> <ul style="list-style-type: none"> <li>CAREX DIVULSA</li> <li>MUHLENBERGIA DUBIA 'PINE MUHLY'</li> <li>IRIS DOUGLASIANA 'CANYON SNOW'</li> <li>MONARDELLA VILLOSA 'RUSSIAN RIVER'</li> <li>SALVIA SPATHACEA 'HUMMINGBIRD SAGE'</li> <li>SALVIA 'DARA'S CHOICE'</li> </ul> |
|---|--|---|

PLEASE SEE RELATED IMAGES ON THE NEXT PAGE

OWNER  
**HEC**  
 HENSEL PHELPS  
 suda  
 BUILDING T1  
 FDP PACKAGE  
 PROJECT

**WEST OAKLAND BART**  
 1451 7th St, Oakland, CA 94607

ARCHITECT  
**jrdr**  
 ARCHITECTS

PROJECT TEAM  
 CIVIL ENGINEERS  
 TARRIL CALIFORNIA  
 8115, SUITE 400  
 PALM BEACH GARDENS  
 CA 33408  
 (561) 840-2200  
 PDA DESIGN  
 444 13th Street  
 DUBLIN  
 CA 94568  
 (916) 853-1364  
 STON  
 1449 First Street  
 SAN FRANCISCO  
 CA 94111  
 (415) 391-1500

STAMP

KEY

PROJ.# 09-153 WO BART  
 DATE 09/24/10  
 SCALE 1"=60'-0"  
 TITLE  
**PLANTING ZONE**

SHEET **L1.07**

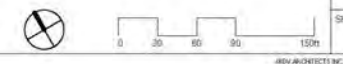

# TREES

## STREET TREES



ACER RUBRUM 'ARMSTRONG'



QUERCUS COCCINEA



AFROCARPUS FALCATUS



PISTACIA CHINENSIS

## PLAZA TREES



POPULUS DELTOIDES



CHITALPA TASHKENTENSIS



ALBIZIA JULIBRISSIN

# SHRUBS & GROUNDCOVER

## PLANTING ZONE 1 : ON THE PLAZA



CAREX DIVULSA



PHORMIUM 'YELLOW WAVE'



BERBERIS 'ORANGE ROCKET' 4'H X 2'W

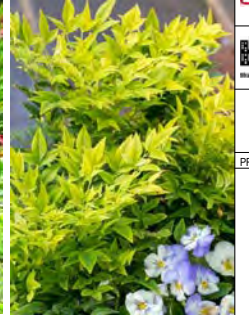

NANDINA DOMESTICA ALBA 'LEMON-LIME' 4'H X 3'W



CORDYLIN 'DESIGN-A LINE' 3'X3'



PITTOSPORUM TOBIRA 'MOJO' 3'X3'



DIGIPLEXIS ILLUMINATION 'APRICOT' 2'H X 18"W



IRIS DOUGLASIANA 'CANYON SNOW'



MUHLENBERGIA DUBIA 'PINE MUHLY'

## PLANTING ZONE 2 : UNDER THE TRUCK



MAHONIA 'SOFT CARESS' 4'X4'



PHORMIUM 'YELLOW WAVE'



CORDYLIN 'DESIGN-A LINE' 3'X3'



EUPHORBIA CHARACIAS SSP.



BLECHNUM SPICANT 'DEER FERN'



WOODWARDIA FIMBRIATA 'GIANT CHAIN FERN'



HELLEBORUS ARGUTIFOLIUS 3'X3'



MUHLENBERGIA DUBIA 'PINE MUHLY'

## PLANTING ZONE 3 : IN THE ALLEY



MUHLENBERGIA DUBIA 'PINE MUHLY'



MONARDELLA VILLOSA 'RUSSIAN RIVER'



IRIS DOUGLASIANA 'CANYON SNOW'



SALVIA SPATHACEA 'HUMMINGBIRD SAGE'



SALVIA "DARA'S CHOICE"



CAREX DIVULSA

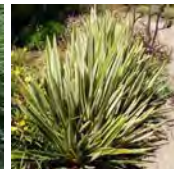

PHORMIUM TONY TIGER' 2.5'X2.5

OWNER  
 HENSEL PHELPS

BUILDING T1 FDP PACKAGE

PROJECT

**WEST OAKLAND BART**  
 1451 7th St, Oakland, CA 94607

ARCHITECT  
 ARCHITECTS

PROJECT TEAM  
 BKF ENGINEERS  
 1566 N. CALIFORNIA BLVD, SUITE 400  
 WALNUT CREEK, CA 94599  
 (925) 940-2200  
 © Robert Perry

PGA DESIGN  
 444 17th Street  
 Oakland, CA 94612  
 (510) 465-1284

STOK  
 945B Front Street  
 San Francisco, CA 94111  
 (415) 329-7100

STAMP

KEY

PROJ #: 168-153 WO BART  
 DATE: 06/04/20  
 SCALE:  
 TITLE: LANDSCAPE PLANTS

SHEET: **L1.08**

JRDV ARCHITECTS INC. COPYRIGHT © 2015. ALL RIGHTS RESERVED.

**CAST-IN-PLACE CONCRETE PAVING**



COLORED C.I.P w/ SAWCUT BANDING

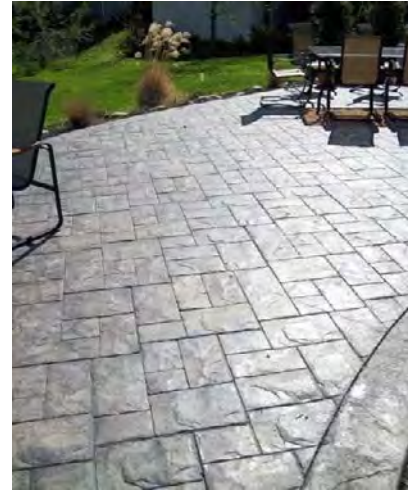

COLORED C.I.P w/ SAWCUT BANDING



C.I.P w/ SAWCUT BANDING

NOTE: ALL PAVING SHALL BE ADA COMPLIANT AND MINIMIZE UNDULATING AFFECTS WHEN TRAVELING OVER SURFACE

**PLANTER WALL**



POUR-IN-PLACE CONCRETE WITH SACK FINISH

**SITE FEATURES**



SLOPED TURF



EVENT PLAZA

**SITE FURNITURES**



BENCH: MODEL: NEW STANDARD BENCH, MANUFACTURER: STREETLIFE, TEL: 215.247.0148, WEBSITE: <https://www.streetlife.nl/us>



BIKE RACK: MODEL: BOLA BIKE RACK, MANUFACTURER: LANDSCAPEFORMS, TEL: 800.430.6209, WEBSITE: <https://www.landscapeforms.com/en-US>



TRASH BIN: MODEL: CHASE PARK LITTER, MANUFACTURER: LANDSCAPEFORMS, WEBSITE: <https://www.landscapeforms.com/en-US>



PICNIC TABLE SET: MODEL: GRETCHEN PICNIC TABLE, ADA COMPLIANT STYLE, MANUFACTURER: LANDSCAPE FORMS, TELEPHONE: 800.430.6209, WEBSITE: [WWW.LANDSCAPEFORMS.COM](http://WWW.LANDSCAPEFORMS.COM)

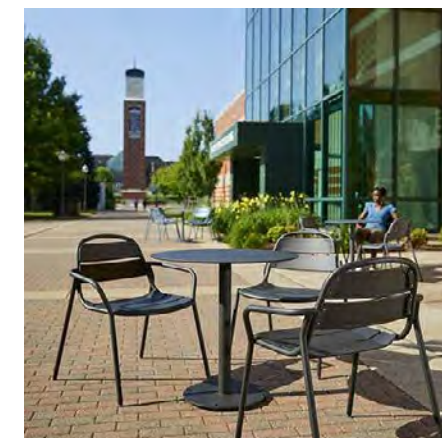

DINING TABLE & CHAIR SET: 21 CHAIR WITH ARMS BY LANDSCAPE FORMS, 4 CHAIRS PER TABLE, CATENA TABLE, 48" DIAMETER, NO UMBRELLA HOLE, ADA COMPLIANT QUAD SUPPORT LEGS, ADJUSTABLE GLIDES. FINISH: LANDSCAPE FORMS PROPRIETARY PANGARD II® POLYESTER POWDERCOAT COLOR: TBD FROM MANUFACTURER'S STANDARD PALETTE MANUFACTURER: LANDSCAPE FORMS, TELEPHONE: 800.430.6209, WEBSITE: [WWW.LANDSCAPEFORMS.COM](http://WWW.LANDSCAPEFORMS.COM)



OWNER

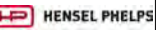

BUILDING T1  
FDP PACKAGE

PROJECT

**WEST OAKLAND BART**  
1451 7th St, Oakland, CA 94607

ARCHITECT



PROJECT TEAM



STAMP

KEY

PROJ #: 168-153 WO BART

DATE: 06/04/20

SCALE:

TITLE:

**LANDSCAPE MATERIALS**

SHEET: **L1.09**

STREET LIGHT

# Domus Luminaire



**Manufacturer(s):** Lumec  
**Catalog #:**  
 DMS50-HPS-SC3M-5MB-SCITX (Large Domus)  
 DOSHPS-SG3-5MB-SCITX-LMS (Small Domus)  
**Photometric File:**  
 50105312.ies (Domus DMS50, 200-250W)  
 50206072.ies (Domus DOS, 35-150W)  
**Application:**  
 Domus DMS50 - Arterial and/or collector street lighting  
 Domus DOS - Residential street lighting and/or sidewalk side pedestrian lighting  
**Lamp Type:** 35W, 100W, 150W, 250W HPS  
**Optical System:** Type III  
**Ballast Voltage:** Multi-tap 120/240V  
**Color:** Teal Green only  
**Special Requirements:**  
**Luminaire Cost:** \$\$\$

As shown: Domus DOS luminaire w/ 3' arm on 16' octagonal pole.  
 Color: Teal Green  
 Location: Coliseum Gardens  
**Public Works Agency  
 Electrical Services Division  
 Dept of Infrastructure and Operations**

Page 19 of 71

STREET LIGHTS

PEDESTRIAN LIGHTING



PLAZA LIGHTS



landscape lighting

landscape lighting

PEDESTRIAN ACCENT LIGHT



OVERHEAD CABLE LIGHTS

**selux**

**Low-voltage LED Ceiling**

**Specifications:**  
**Luminaire Housing/Hanger:** Constructed from high strength polycarbonate. Hanger brackets are made of stainless steel. Hanger brackets are made of stainless steel. Hanger brackets are made of stainless steel.  
**LED Driver:** LED driver is fully compliant (passive current programmable LED driver). Driver provides 90% efficiency for 50% over the requirements of IES and includes a 5 Year warranty.  
**LED Array:** 100% dimmable LED array. LED array is made of high quality LEDs. LED array is made of high quality LEDs. LED array is made of high quality LEDs.  
**LED Optics:** LED optics are made of high quality materials. LED optics are made of high quality materials. LED optics are made of high quality materials.

**Settings and Ratings:** Luminaire rated to 1000V and 1000W. Luminaire is rated to 1000V and 1000W. Luminaire is rated to 1000V and 1000W.

**Warranty:** 5 Year Limited LED Luminaire Warranty. 5 Year Limited LED Luminaire Warranty. 5 Year Limited LED Luminaire Warranty.

# ALCOTT AREA LIGHT



**General Description**  
 The Alcott Area Light is a contemporary interpretation of a traditional outdoor lamp. Its simple, clean lines are perfect for a modern, energy-efficient LED luminaire. With its minimalist design, the Alcott Area Light is a perfect choice for any outdoor lighting project.

**Electrical**  
 Single primary 100V/277V/347V AC, Class 2, 24VDC driver (integrated with LED array) with built-in surge protection. LED array with built-in surge protection. LED array with built-in surge protection.

**Alcott Type 3**  
 Type 3: 200W, 277V, 200W, 277V, 200W, 277V.  
**Alcott Type 5**  
 Type 5: 200W, 277V, 200W, 277V, 200W, 277V.

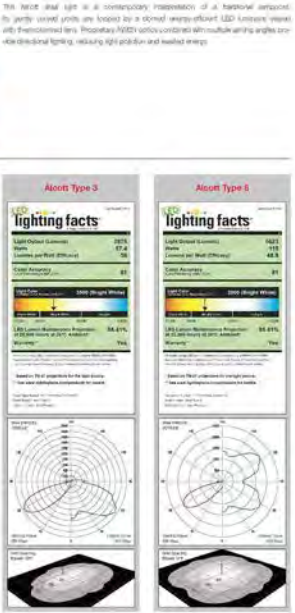

# ALCOTT AREA LIGHT



**Finish**  
 The Alcott Area Light is available in a variety of finishes. The finishes are: Teal Green, White, Black, and Bronze. The finishes are: Teal Green, White, Black, and Bronze.

**To Order**

Product	Lamp	Ballast	Color	Height	Weight
AC	100W	100W	Teal Green	16'	150 lbs
AC	150W	150W	Teal Green	16'	150 lbs

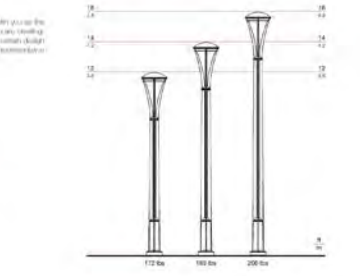

UNDERTRACK LIGHTING

**LIQMAN LIGHTING USA**

**UZA-20001 Zaab 2 Single Side Cluster Column**

**Construction:** The UZA-20001 is constructed from high quality materials. The UZA-20001 is constructed from high quality materials. The UZA-20001 is constructed from high quality materials.

**Adjustable surface spotlight family:** The UZA-20001 is an adjustable surface spotlight. The UZA-20001 is an adjustable surface spotlight. The UZA-20001 is an adjustable surface spotlight.

**Hardware:** The UZA-20001 includes a variety of hardware. The UZA-20001 includes a variety of hardware. The UZA-20001 includes a variety of hardware.

**Options:** The UZA-20001 is available in a variety of options. The UZA-20001 is available in a variety of options. The UZA-20001 is available in a variety of options.



**OWNER**  
 HENSEL PHELPS

**suda**  
 Strategic Urban Development Alliance, LLC

**BUILDING T1  
 FDP PACKAGE**

**PROJECT**

**WEST OAKLAND BART**  
 1451 7th St, Oakland, CA 94607

**ARCHITECT**  
 jrdv ARCHITECTS

**PROJECT TEAM**

**STOK**  
 9450 Front Street  
 San Francisco CA 94111  
 (415) 329-7100

**PROJ #:** 168-153 WO BART  
**DATE:** 06/04/20  
**SCALE:**  
**TITLE:** LIGHTING IMAGES  
**SHEET:** L1.10

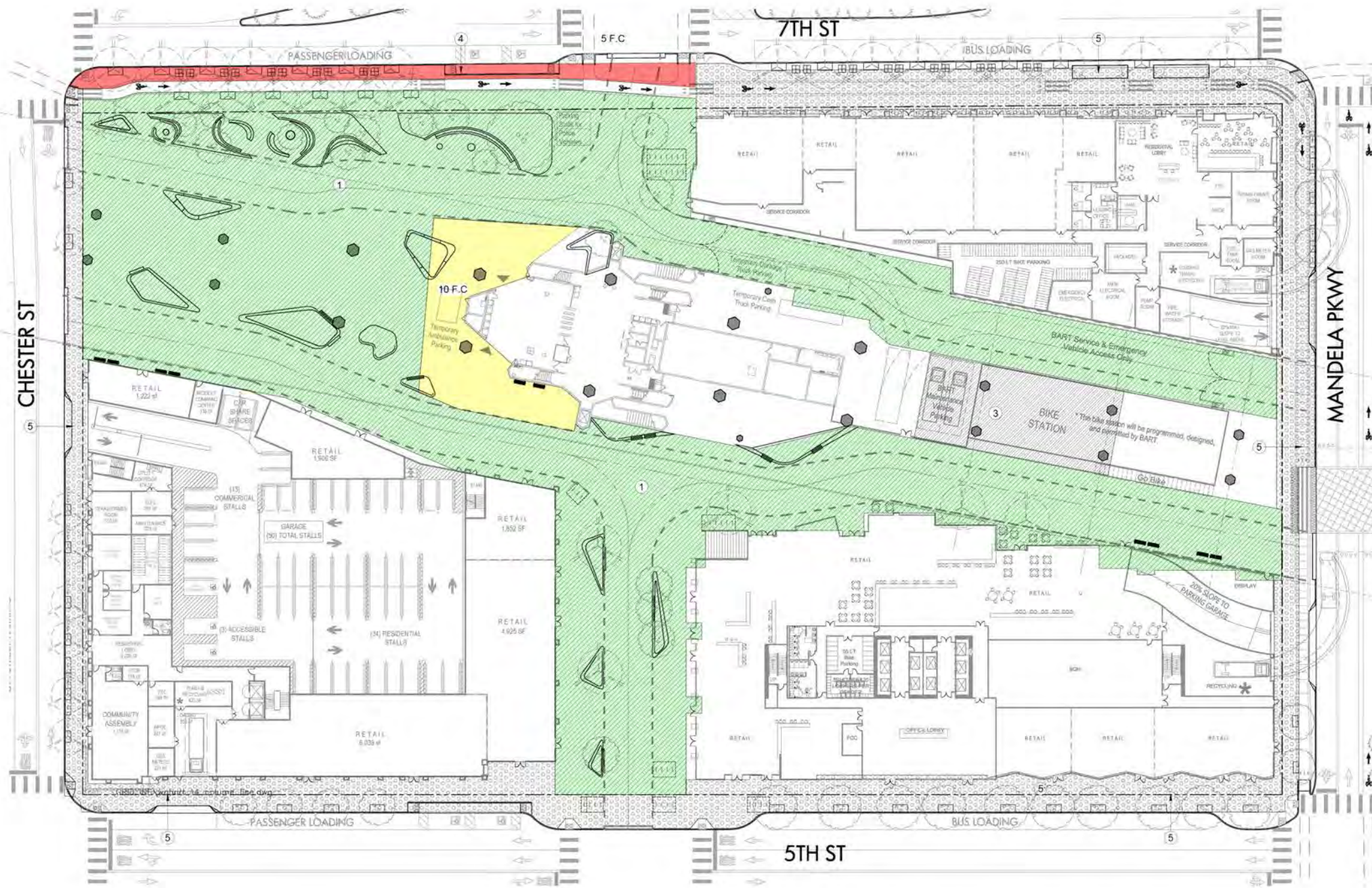

**LIGHTING PHOTOMETRIC GOALS**

AREA	FOOT CANDLE	LIGHT TYPE	CONTROLS
1. PEDESTRIAN WALKWAY	2 MIN	LED	POWER-LINE CARRIER TECHNOLOGY
2. EXTERIOR PATRON WAITING AREA	10	LED	DIMMABLE, TO REDUCE CONTRAST
3. BIKE LOCKER AREA	10	LED	SAME AS SURROUNDING SPACE
4. LOADING, UNLOADING, KISS-AND-RIDE AREAS, AND PEDESTRIAN WALKWAYS	5	LED	PHOTOCELL AND POWER-LINE CARRIER TECHNOLOGY OR WIRELESS CONTROL
5. OTHER EXTERIOR SPACES	1.25	LED	POWER-LINE CARRIER





1 - Mandela Plaza Center Street Entrance



2 - Artwalk from Center Street



3 - Undertrack Plaza from Artwalk



4 - Mandela Plaza Chester Street Entrance and Blues Walk of Fame



**MANDELA STATION  
@WEST OAKLAND  
BART**  
1451 7th St, Oakland,  
CA 94607

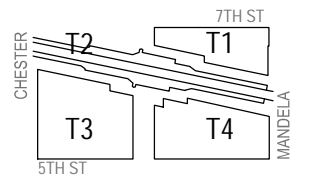

JRDV Architects, Inc  
The Cathedral Building  
Broadway and Telegraph  
PO Box 70126  
Oakland, CA 94612 USA  
510 295 4392 T  
www.jrdv.com



PROJ. # 168-153 WO BART

DATE: July 24, 2020

**LANDSCAPE  
VIEWS**

SHEET:

**L-1.12**

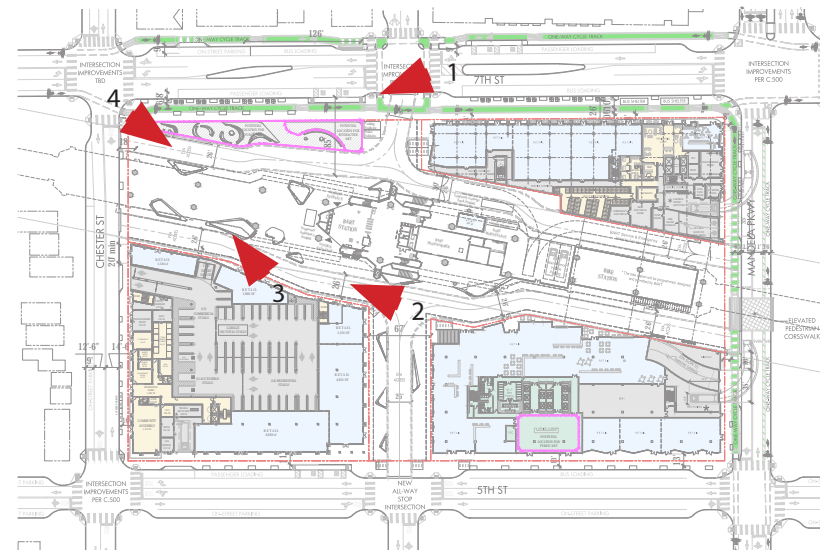

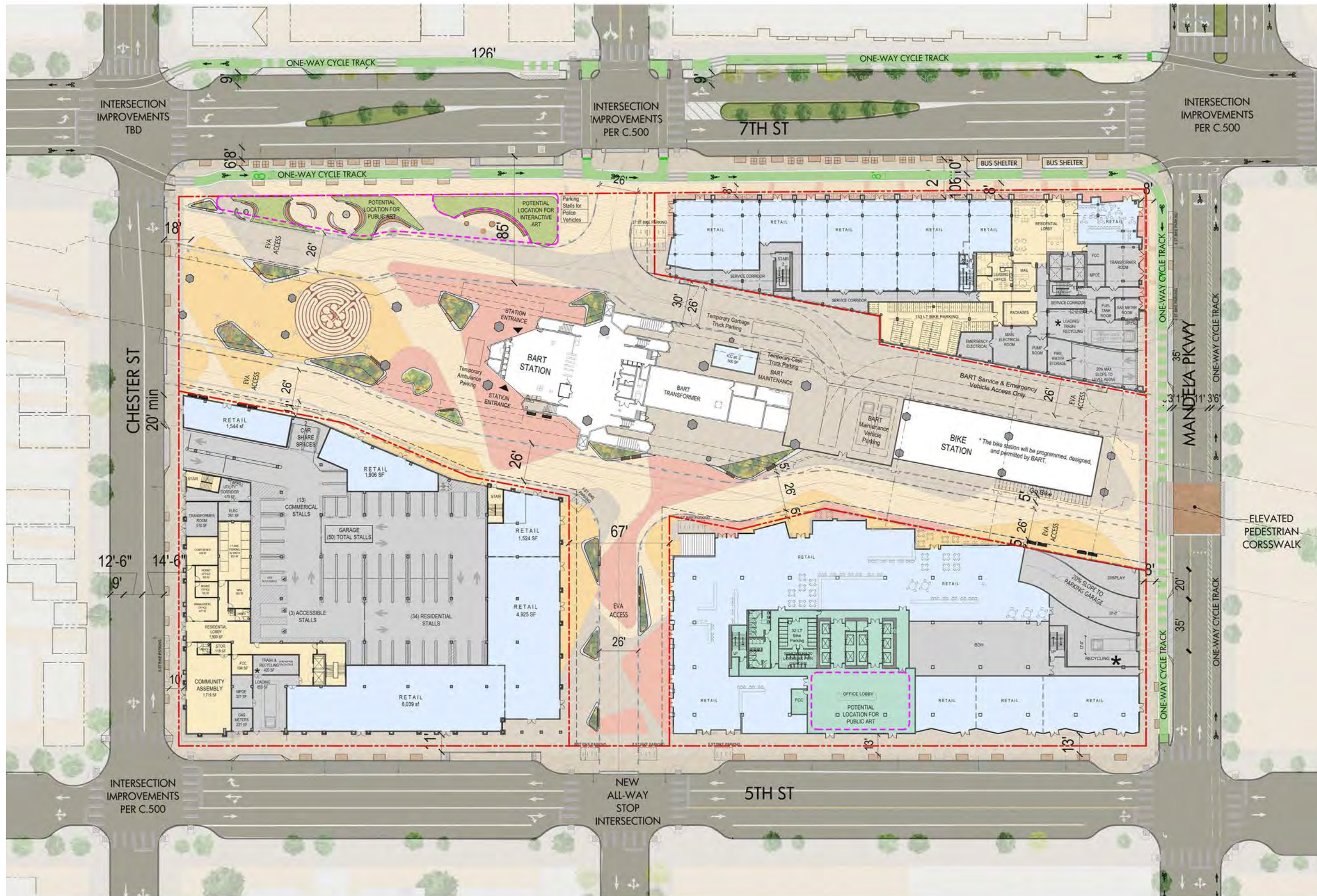

**MANDELA STATION**  
**@WEST OAKLAND**  
**BART**  
 1451 7th St, Oakland,  
 CA 94607

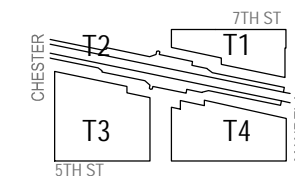

JRDV Architects, Inc  
 The Cathedral Building  
 Broadway and Telegraph  
 PO Box 70126  
 Oakland, CA 94612 USA  
 510 295 4392 T  
 www.jrdv.com

ENGINEERS, SURVEYORS, PLANNERS  
  
  
 LANDSCAPE ARCHITECTS

PROJ. # 168-153 WO BART  
 DATE: July 24, 2020

**SITE PLAN**

SHEET:

A-9.01

The recycling space on T1 site is 1,150 cubic feet minimum, on T3 site is 510 cubic feet minimum, and on T4 site is 647 cubic feet minimum. The total recycling space on site is 2,307 cubic feet minimum.

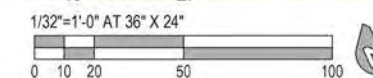



# Public Space Design

## Public Space Improvements:

The public spaces for the Mandela Station site are designed to reinforce the vibrant mixed-use development that furthers Oakland's efforts to promote urban living at key transit sites, and provides an active and delightful center for the West Oakland community.

The site is designed with a series of important civic open spaces, including:

- Mandela Plaza, a major community civic plaza at 7th Street fronting BART Station entrance. This plaza is designed with varied paving and green spaces. It is designed with a delightful series of sculptural seating areas arranged to promote community interaction – a “Living Room” for the residents and surrounding neighborhood.
- Center Square, a pedestrian plaza replacing the vacated Center Street. This plaza is focused on providing food related tenants along T3 and T4, and will be designed with fixed and permanent seating to become a destination food hub for the neighborhood, BART patrons and the on-site residents.

- Art Alley, a pedestrian paseo that activates the area south of the BART tracks. This area is lined with small gallery spaces and will have a expansive “art wall” along the north façade of T3 framing the alley space.

- Undertrack Area, a flexible event space that will provide a venue for the programs that activate Mandela Plaza and Art Alley. The under track will feature movable food kiosks, pop-up events, farmers markets, art fairs, live music and other programmed events that will help make Mandela Station a destination location.

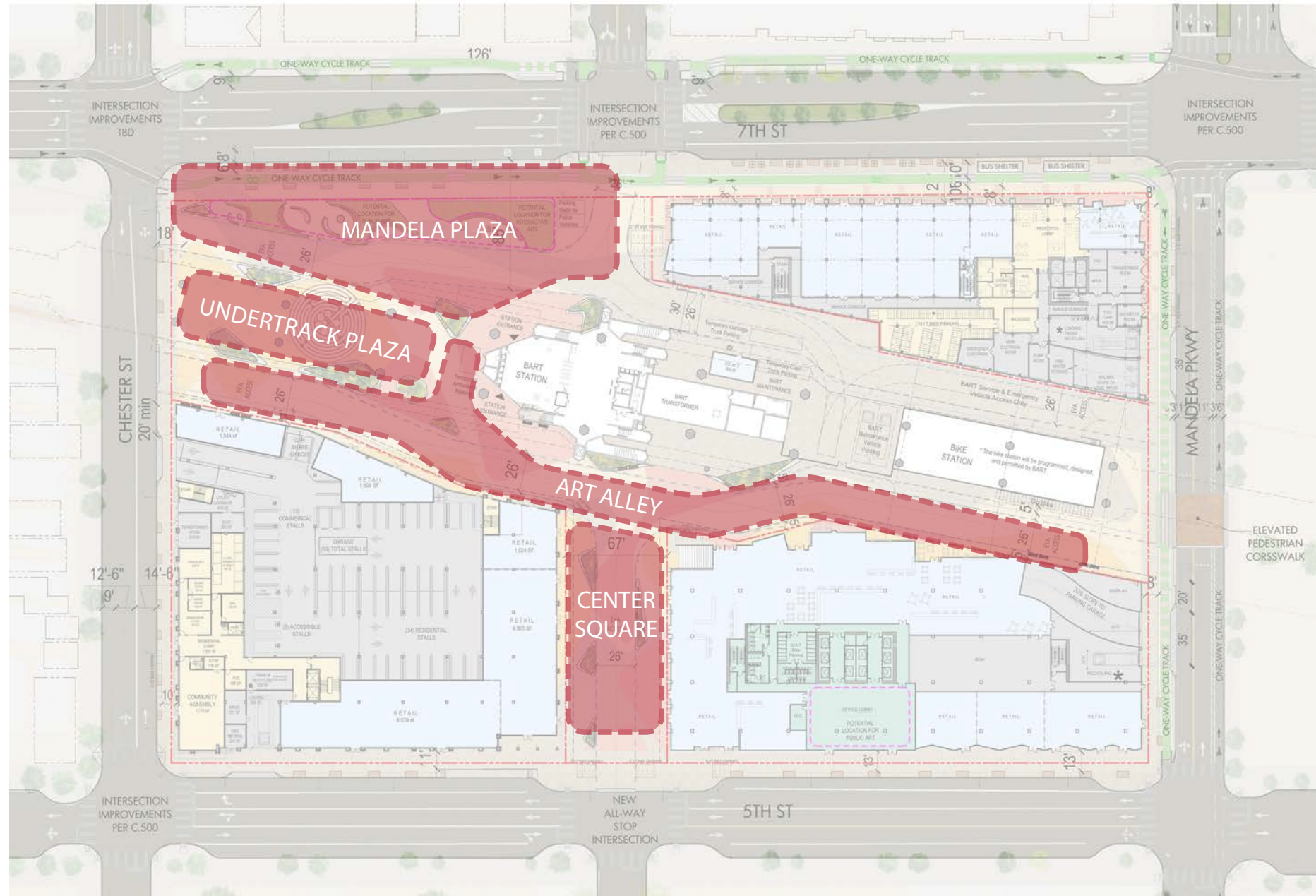

**Hardscape and Green-scape Design:** Landscape plan is designed to enhance the pedestrian public spaces, and to create a high quality of pedestrian experience and civic prominence. The existing trees will be replaced because of conflicts with the access plan. The new tree planting complements the overall landscape strategy of the 7th and 5th Street corridors to ensure a continuous, interesting and varied visual experience.

**Landscape Materials:** The landscape materials are designed with pavers or stamped concrete and other decorative materials to create a high quality public pedestrian experience and to maximize the types of uses that can occur on site. The landscape is designed to become a catalyst to a larger vision for the 7th Street corridor. The new tree planting complements the overall landscape strategy of the 7th Street corridor to ensure a continuous, interesting and varied visual experience.

**Site Lighting:** The Lighting plan is designed to create well lighted plazas and pedestrian pathways through the site. The visual security of all pedestrian spaces within the site is facilitated by locating retail and other public activities along all edges of the development. The landscape plan provides adequate lighting to provide a safe environment while conforming to current best practices to mitigate light pollution.



## MANDELA STATION @WEST OAKLAND

### BART

1451 7th St, Oakland,  
CA 94607

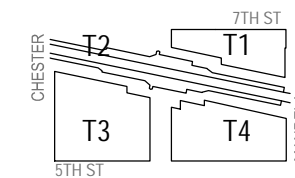

JRDV Architects, Inc  
The Cathedral Building  
Broadway and Telegraph  
PO Box 70126  
Oakland, CA 94612 USA  
510 295 4392 T  
www.jrdv.com



PROJ. # 168-153 WO BART

DATE: July 24, 2020

## PUBLIC SPACE IMPROVEMENT: PUBLIC SPACE DESIGN

SHEET:

A-9.01

# Mandela Plaza

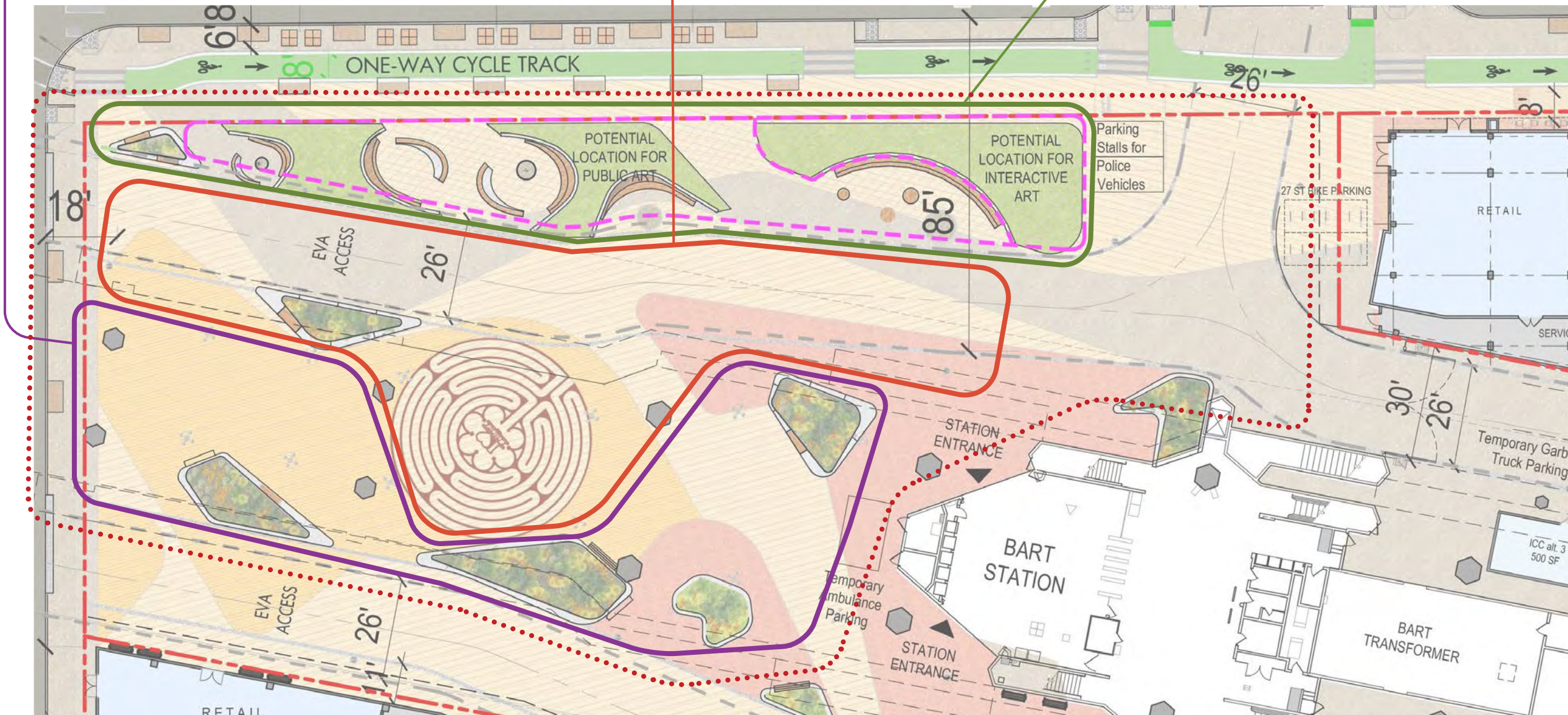

MANDELA STATION  
@WEST OAKLAND  
BART  
1451 7th St, Oakland,  
CA 94607

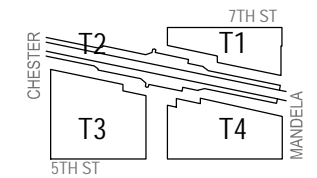

JRDV Architects, Inc  
The Cathedral Building  
Broadway and Telegraph  
PO Box 70126  
Oakland, CA 94612 USA  
510 295 4392 T  
www.jrdv.com



PROJ. # 168-153 WO BART  
DATE: July 24, 2020

PUBLIC SPACE  
IMPROVEMENT:  
MANDELA PLAZA

SHEET: A-9.02

Note: Undertrack painting is optional pending BART's approval.

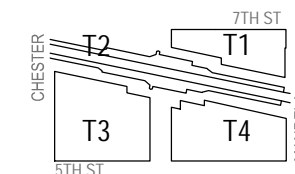
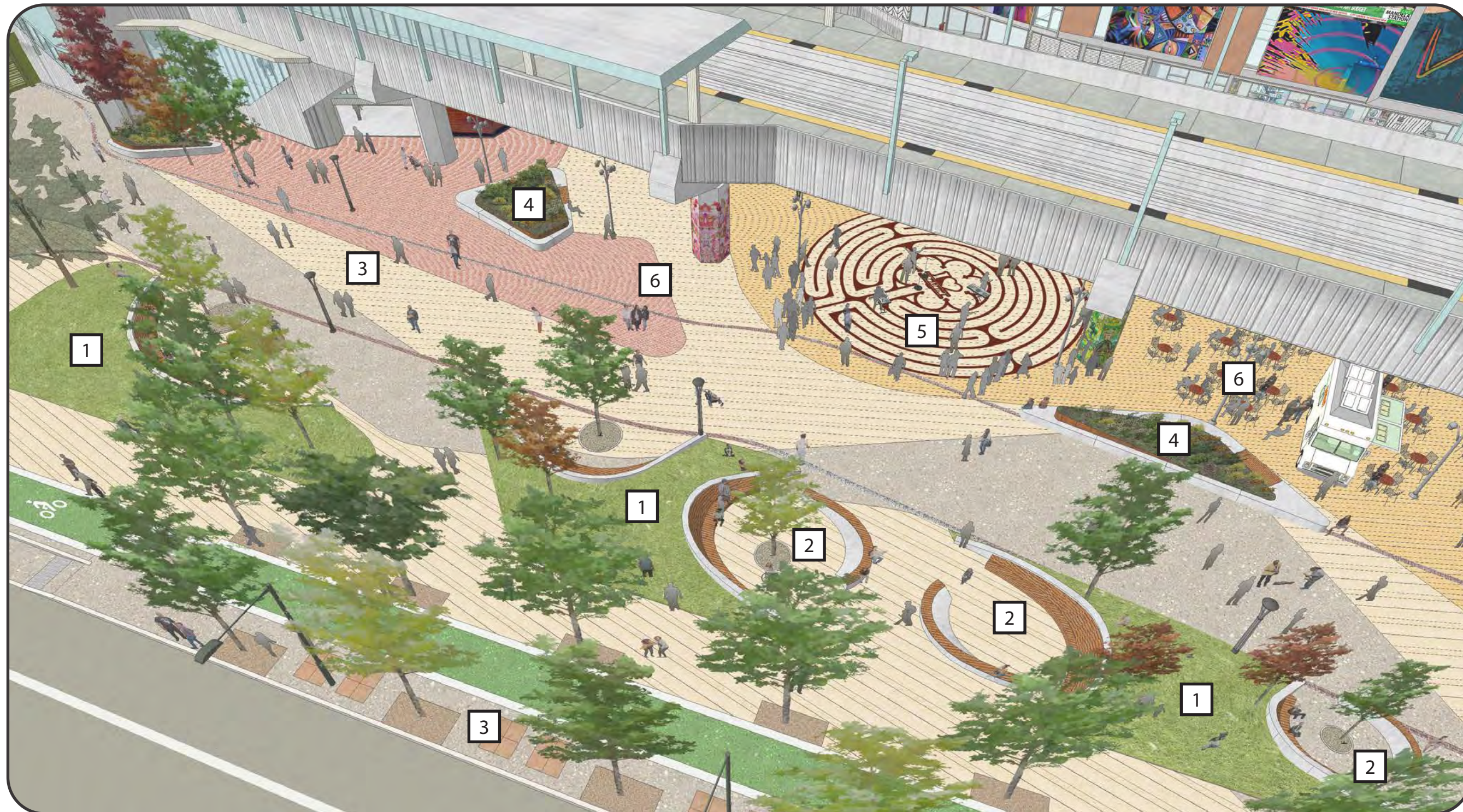

## Mandela Plaza Features

- 1** SCULPTED BERMS - Artificial turf berms to promote informal seating and interactive play options for a wide range of age groups.
- 2** OUTDOOR 'LIVING ROOMS' - Nodes framed with integral bench seating for small gatherings.
- 3** BLUES WALK OF FAME - Relocated plaques cast into 7th Street sidewalk paving north of Mandela Plaza and the T1 building.
- 4** BENCH PLANTERS - Concrete planters with consistent, bench-height edge to provide fixed seating option for plaza events.
- 5** MAZE STRIPING - Maze for public interaction. This open space is flexible for performances and other event activities.
- 6** ADDITIONAL OPEN SPACE - Framed open space for food trucks, outdoor dining, and other temporary programming.

# CHILDREN'S INTERACTIVE ART

LOCATION OPTION 1  
LOCATION OPTION 2

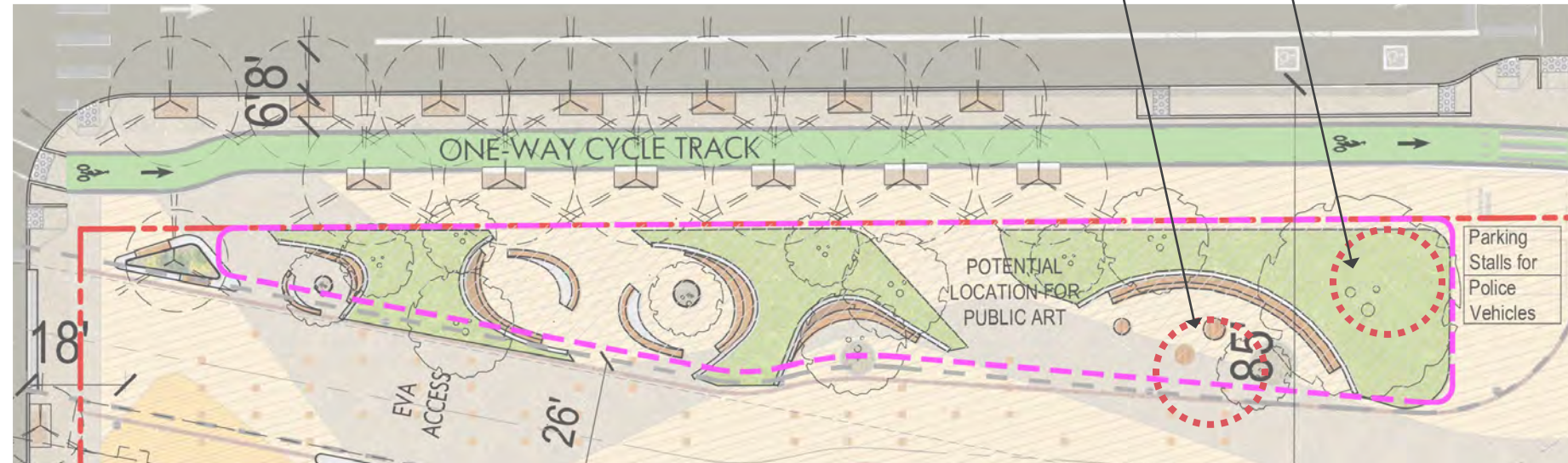

**MANDELA STATION  
@WEST OAKLAND  
BART**  
1451 7th St, Oakland,  
CA 94607

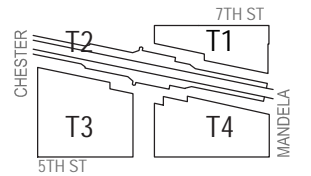

JRDV Architects, Inc  
The Cathedral Building  
Broadway and Telegraph  
PO Box 70126  
Oakland, CA 94612 USA  
510 295 4392 T  
www.jrdv.com



PROJ. # 168-153 WO BART  
DATE: SEPTEMBER 04, 2020

## CHILDREN'S INTERACTIVE ART

SHEET:

A-9.04

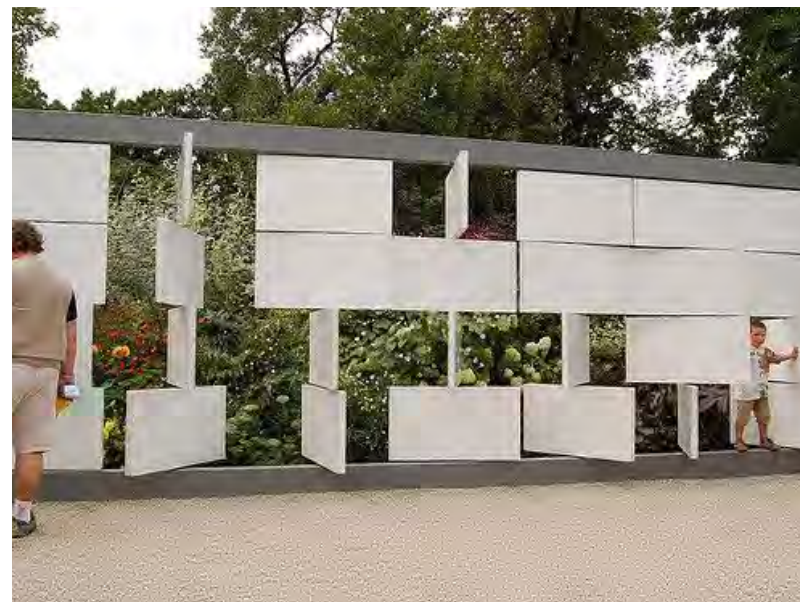

# Public Space Programming and Activation

The Developer will provide regular programming in the public plazas of the proposed Mandela Station at West Oakland BART Station as required in the Conditions of Approval (COA #66) approved on February 6, 2019 by the City of Oakland Planning Commission. The purpose of the programming is to provide future BART riders, project-site residents, shoppers and workers, and the larger community of West Oakland with excellent opportunities to relax and enjoy as well as providing local businesses and non-profits to financially support themselves and promote their services and products.

Programmed events may include:

1. Concert events will be held on a monthly schedule in co-operation with the Developer and local non-profit Zoo Labs among others. Zoo Labs empowers music artists as leaders and directs resources toward their ventures.
2. Farmers Market events will be held monthly in collaboration with the Mandela Grocery Cooperative, a worker-owned grocery store that provides nourishing foods and enhanced opportunities for food vendors, including the Freedom Farmers Market weekly from July to November.
3. Local vendor Pop-Ups events will be held monthly and co-sponsored by PopUp Village. Popupvillage.org features opportunities including:
  - Arts and Culture classes and exhibits
  - Food & Agriculture
  - Health & wellness
  - Youth Activities
  - Highlights local retail vendors
  - Performers of music, dance, spoken word
  - Education
  - These are a few of the collaborator of existing programs on 7th Street that as developers we intend to support and expand in collaboration with these organizations.

All program schedules and events will be advertised widely using: BART Station Public Information System, the networks of organizations that participated in the West Oakland Advisory Committee process and the local media outlets.



Community Art Fair



Local Farmers Market



Undertrack Program Events



Food Truck Events



Undertrack Program Events



Undertrack Program Events



Food Truck Events



Sunday Music Show

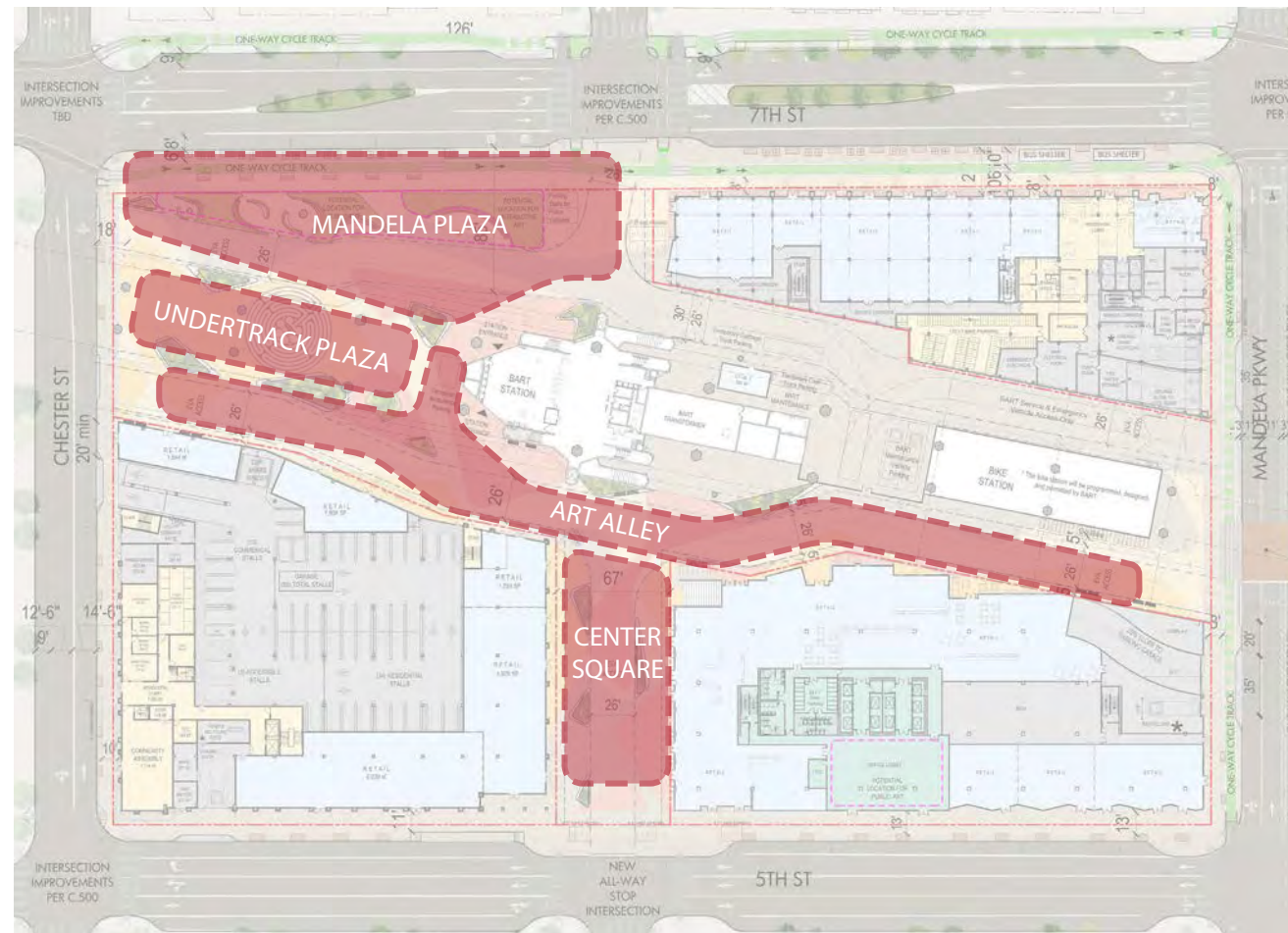

Public Open Space Map



**MANDELA STATION  
@WEST OAKLAND  
BART**  
1451 7th St, Oakland,  
CA 94607

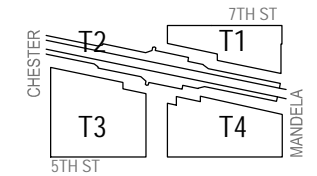

JRDV Architects, Inc  
The Cathedral Building  
Broadway and Telegraph  
PO Box 70126  
Oakland, CA 94612 USA  
510 295 4392 T  
www.jrdv.com



PROJ. # 168-153 WO BART  
DATE: July 24, 2020

## EVENT SPACE PROGRAM

SHEET:

# Under Track Strategy

The Under-Track area is designed to integrate with both Mandela Plaza on 7th Street and Art Alley to the south. These combination of these spaces are planned to be programmed and perceived both separately and as linked spaces.

**Programmed Activation.** Under-Track area is designed as a flexible and activated space that will support food kiosks, exhibits and a wide range of staged events. The physical space of the Under-Track area serves these programmed activities by creating a defined space with high “ceiling” and significant scale, that is visually connected to the surrounding Public Spaces. The space also functions as an interesting urban plaza when no events are staged. It becomes an delightful and safe passage through the site.

**Landscape Paving.** The paving patterns are designed to define the space and encourage pedestrians to flow through the space. The variety of paving materials is designed to reduce the scale of the space, by implying nodes and clusters that can contain smaller groups or events. The paving pattern and variety of materials will also create a visually interesting plaza surface that does not require any activation or events.

**Seating.** Seating is provided with a combination of fixed-seating that is integrated into the planters. And, movable café-seating and tables to be placed and managed by specific events. The goal is to promote this space as both safe pedestrian passage through the site, and as a place to rest or participate in a planned event. The number of movable seats will be managed by the client and will respond to the actual demand.

**Lighting.** The lighting of the Under-Track area is designed to provide a high level of ambient light and “decorative” feature lighting. The ambient light is provided by a double row of 10’high light standards with a fixture that provide directional up-lighting and ground-lighting. Feature lighting will be provided with either fixtures attached to the BART structure, or fixtures attached to the light standards. This lighting will provide changeable artistically colored lighting that creates a powerful night presence that extends to the plaza and 7th Street. Lighting levels are designed to ensure visual safety for this space at all times.

**Decorative Surface Painting.** The columns of the BART structure may be painted with a surface graphic that is colorful and visually animates the space. This painted surface will create a delightful backdrop that will enhance the space for events and for the enjoyment of the public.

Note: Undertrack painting is optional pending BART’s approval.



1 - From BART Station North Entrance



2 - From Art Walk



3 - From Mandela Plaza



4 - From Under Track Plaza

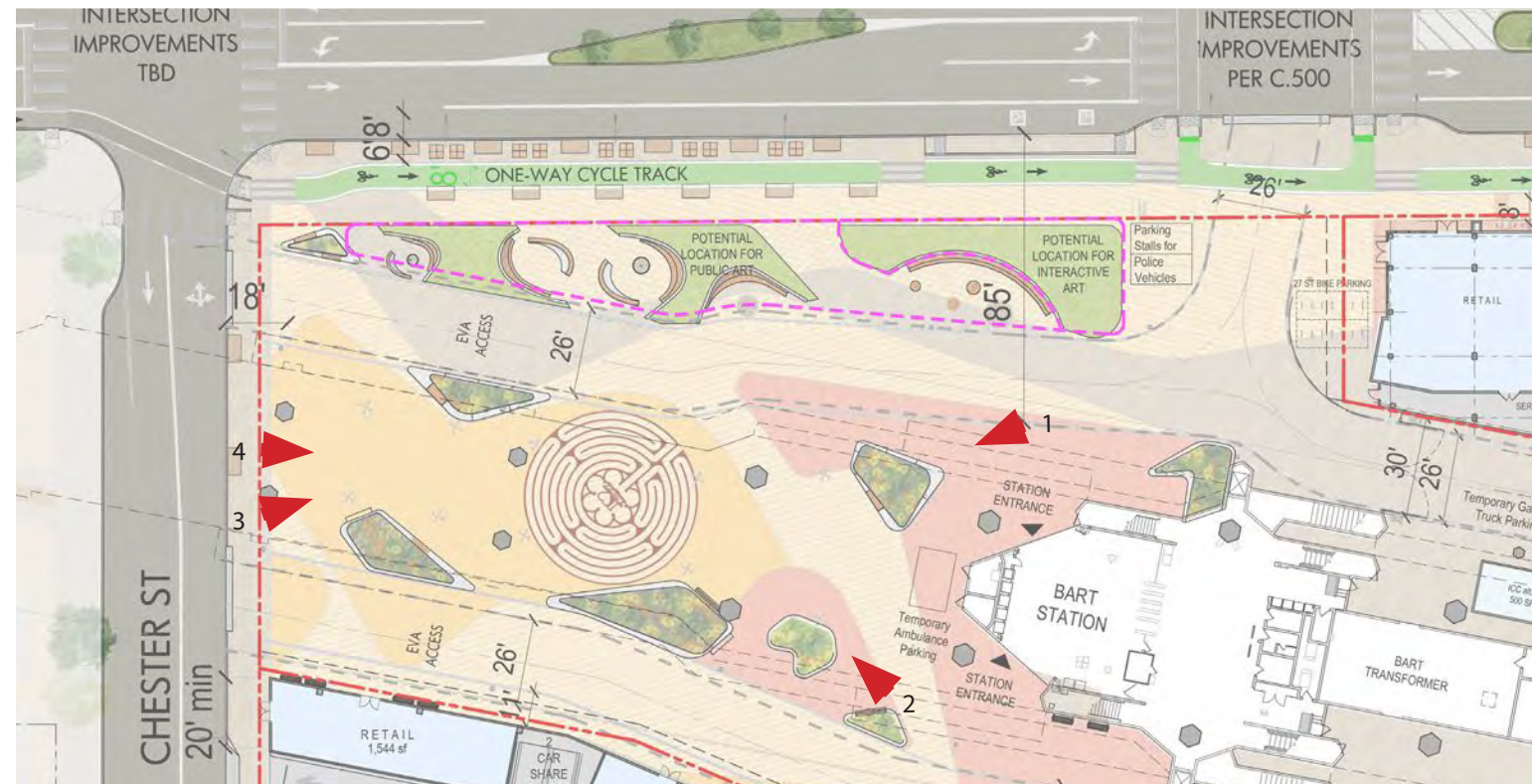

Partial Site Plan

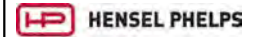
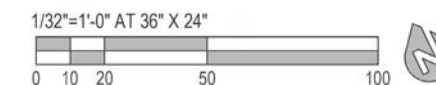

**MANDELA STATION  
@WEST OAKLAND  
BART**  
1451 7th St, Oakland,  
CA 94607

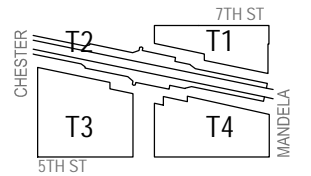

JRDV Architects, Inc  
The Cathedral Building  
Broadway and Telegraph  
PO Box 70126  
Oakland, CA 94612 USA  
510 295 4392 T  
www.jrdv.com



PROJ. # 168-153 WO BART

DATE: July 24, 2020

**UNDER TRACK  
SPACE**

SHEET:

**A-9.06**

# Under-Track Activation



Farmers Markets



Food Trucks and Mobile Enterprise



Music and Staged Events



Off The Grid Events



Night Markets



Art Fairs and Pop-up Events



MANDELA STATION  
 @WEST OAKLAND  
 BART  
 1451 7th St, Oakland,  
 CA 94607

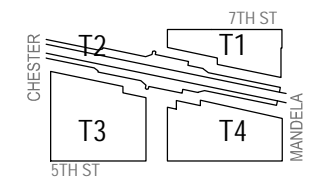

JRDV Architects, Inc  
 The Cathedral Building  
 Broadway and Telegraph  
 PO Box 70126  
 Oakland, CA 94612 USA  
 510 295 4392 T  
 www.jrdv.com



PROJ. # 168-153 WO BART  
 DATE: July 24, 2020

UNDER TRACK  
 SPACE

SHEET:

A-9.07

## Mandela Plaza - Community Civic Space:

This urban plaza creates a major community civic plaza at 7th Street fronting BART Station entrance. It is designed with a delightful series of sculptural seating and green-berm areas arranged to promote community use – a “Living Room” for the residents and surrounding neighborhood. The plaza provides access to the BART station, and also celebrates the civic importance of this site in the community. This plaza is located centrally to the overall site in order to increase its public importance, public access, and public use for community, arts and cultural events. This central plaza is designed to enhance the 7th Street corridor activation and overall public experience.

This plaza is designed with varied paving and green spaces. The Landscape plan is designed to complement the importance and use of the space by the neighborhood and residents on site. The arced cluster seating and green berms along 7th Street create a welcoming pedestrian and community experience.

The new tree planting complements the overall landscape strategy of the 7th Street corridor to ensure a continuous, interesting and varied visual experience. Paving materials are quality pavers or stamped colored concrete and are aesthetically designed to differentiate unique spaces within the pedestrian plazas, promote visual access to the BART station entrance, and to create opportunities for cultural, community and arts events. The landscape plan is designed to create a delightful destination for the West Oakland community and users of the transit hub.



VIEW FROM 7TH STREET



VIEW FROM 7TH STREET

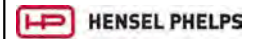

**MANDELA STATION**  
**@WEST OAKLAND**  
**BART**  
 1451 7th St, Oakland,  
 CA 94607

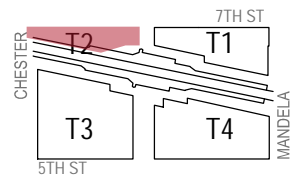

JRDV Architects, Inc  
 The Cathedral Building  
 Broadway and Telegraph  
 PO Box 70126  
 Oakland, CA 94612 USA  
 510 295 4392 T  
 www.jrdv.com



PROJ. # 168-153 WO BART  
 DATE: July 24, 2020

**MANDELA PLAZA**

SHEET:

**A-9.08**





VIEW OF BART ENTRANCE AT 7TH STREET



VIEW FROM CHESTER STREET



**MANDELA STATION**  
**@WEST OAKLAND**  
**BART**  
 1451 7th St, Oakland,  
 CA 94607

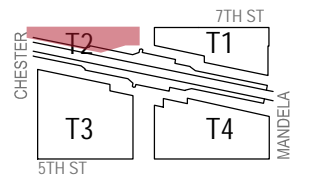

JRDV Architects, Inc  
 The Cathedral Building  
 Broadway and Telegraph  
 PO Box 70126  
 Oakland, CA 94612 USA  
 510 295 4392 T  
 www.jrdv.com



PROJ. # 168-153 WO BART  
 DATE: July 24, 2020

**MANDELA PLAZA**

SHEET:

**A-9.09**



VIEW FROM 7TH STREET



VIEW FROM 7TH STREET



VIEW OF 7TH STREET SIDEWALK AND LANDSCAPED BERM



**MANDELA STATION**  
**@WEST OAKLAND**  
**BART**  
 1451 7th St, Oakland,  
 CA 94607

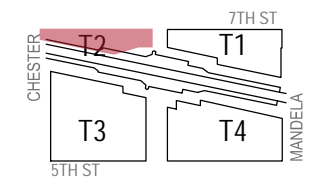

JRDV Architects, Inc  
 The Cathedral Building  
 Broadway and Telegraph  
 PO Box 70126  
 Oakland, CA 94612 USA  
 510 295 4392 T  
 www.jrdv.com



PROJ. # 168-153 WO BART  
 DATE: July 24, 2020

**MANDELA PLAZA**

SHEET:

**A-9.10**



VIEW FROM 7TH STREET



VIEW OF MANDELA PLAZA



**MANDELA STATION**  
**@WEST OAKLAND**  
**BART**  
 1451 7th St, Oakland,  
 CA 94607

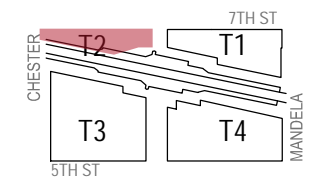

JRDV Architects, Inc  
 The Cathedral Building  
 Broadway and Telegraph  
 PO Box 70126  
 Oakland, CA 94612 USA  
 510 295 4392 T  
 www.jrdv.com



PROJ. # 168-153 WO BART  
 DATE: July 24, 2020

**MANDELA PLAZA**

SHEET:

**A-9.11**

# Art Alley

Art Alley: The mid-block passage south of the BART trackway has been designed as an activated pedestrian paseo. This area is lined will have a expansive “art wall” along the north façade of T3 framing the alley space. Along the Art Alley at T3 will be the Art Wall management offices and shop.

Buildings are set back to provide both adequate emergency vehicle access and to create a delightful and activated pedestrian passage through the site to the BART station. The space is lined with public uses that activate the space, including the Under-Track programmed space and the bike station.

Landscape Materials: The landscape materials are designed with pavers or stamped colored concrete and other materials to create a high quality public pedestrian experience and to enhance the pedestrian experience of circulating through the site and to the BART station.

Site Lighting: The Lighting plan has been designed to create well lit plazas and pedestrian pathways through the site. The visual security of all pedestrian spaces within the site is also facilitated by locating well-lit retail and other public activities along all edges of the development. The landscape lighting complements the overall concept to provide a safe environment while conforming to current best practices to mitigate light pollution.



VIEW FROM CHESTER STREET



VIEW AT CENTER SQUARE



VIEW FROM MANDELA PARKWAY

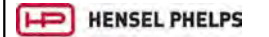

**MANDELA STATION  
@WEST OAKLAND  
BART**  
1451 7th St, Oakland,  
CA 94607

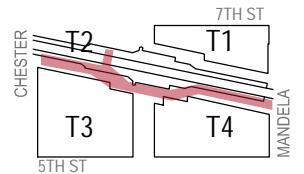

JRDV Architects, Inc  
The Cathedral Building  
Broadway and Telegraph  
PO Box 70126  
Oakland, CA 94612 USA  
510 295 4392 T  
www.jrdv.com



PROJ. # 168-153 WO BART  
DATE: July 24, 2020

# ART ALLEY

SHEET:

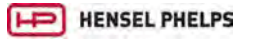

MANDELA STATION  
 @WEST OAKLAND  
 BART  
 1451 7th St, Oakland,  
 CA 94607

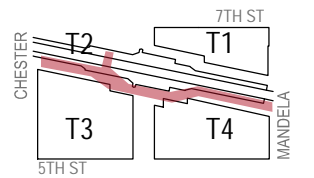

JRDV Architects, Inc  
 The Cathedral Building  
 Broadway and Telegraph  
 PO Box 70126  
 Oakland, CA 94612 USA  
 510 295 4392 T  
 www.jrdv.com



PROJ. # 168-153 WO BART  
 DATE: July 24, 2020

ART ALLEY

SHEET:  
 A-9.14

# Center Square

Center Square: The vacated Center Street has been transformed into an active urban destination for the neighborhood. This space is both an important pedestrian connection to the BART station and a significant public plaza for the surrounding community. It is lined with a wide variety of local food offerings that showcase the cultural and ethnic diversity of West Oakland. The space creates an inviting place for the neighborhood to shop, dine, and relish a quality community experience.

The landscape materials are designed with high quality paver, brick, finished concrete and other materials to create a high quality public pedestrian experience and to maximize the types of uses that can occur on site.

Site Lighting: The Lighting plan has been designed to create a well lit space that connects BART to 5th Street. The visual security of pedestrians within this space is facilitated by locating retail and other public activities along all edges of the development. The landscape plan is designed with adequate lighting to provide a safe environment while conforming to current best practices to mitigate light pollution.



Evening Food Festivals



Neighborhood Food Destination

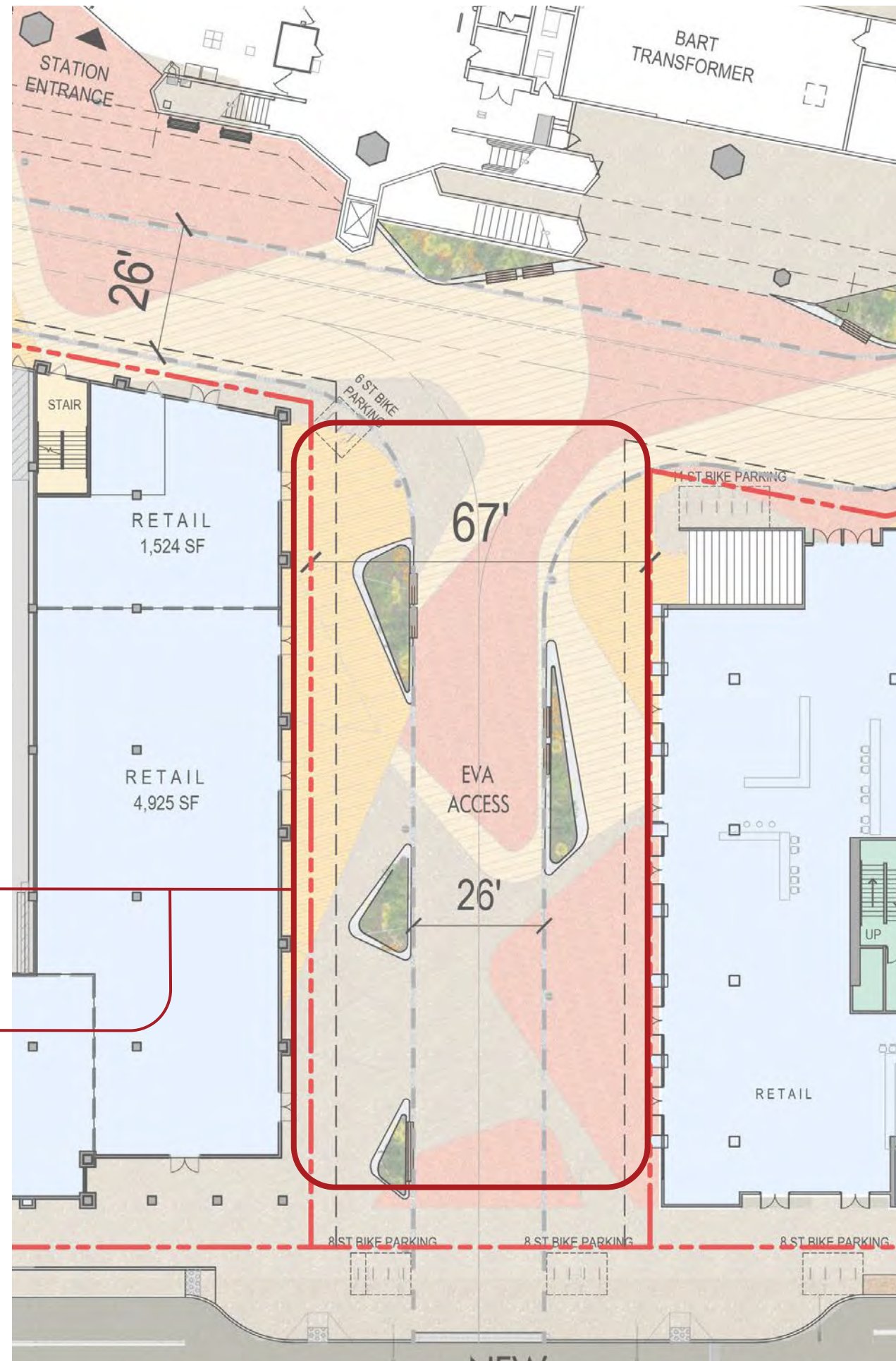

MANDELA STATION  
@WEST OAKLAND

BART  
1451 7th St, Oakland,  
CA 94607

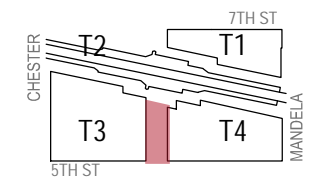

JRDV Architects, Inc  
The Cathedral Building  
Broadway and Telegraph  
PO Box 70126  
Oakland, CA 94612 USA  
510 295 4392 T  
www.jrdv.com



PROJ. # 168-153 WO BART

DATE: July 24, 2020

CENTER  
SQUARE

SHEET:

A-9.15



BIRDSEYE OF CENTER SQUARE



**MANDELA STATION**  
**@WEST OAKLAND**  
**BART**  
 1451 7th St, Oakland,  
 CA 94607

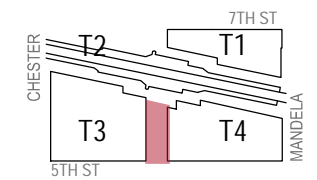

JRDV Architects, Inc  
 The Cathedral Building  
 Broadway and Telegraph  
 PO Box 70126  
 Oakland, CA 94612 USA  
 510 295 4392 T  
 www.jrdv.com



PROJ. # 168-153 WO BART

DATE: July 24, 2020

**CENTER  
 SQUARE**

SHEET:

**A-9.16**



VIEW OF CENTER SQUARE

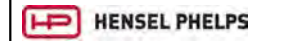

**MANDELA STATION  
@WEST OAKLAND  
BART**  
1451 7th St, Oakland,  
CA 94607

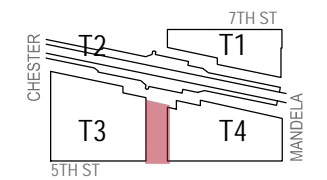

JRDV Architects, Inc  
The Cathedral Building  
Broadway and Telegraph  
PO Box 70126  
Oakland, CA 94612 USA  
510 295 4392 T  
www.jrdv.com



PROJ. # 168-153 WO BART  
DATE: July 24, 2020

CENTER  
SQUARE

SHEET: A-9.17





VIEW FROM 5TH STREET



VIEW OF CENTER SQUARE



**MANDELA STATION  
@WEST OAKLAND**

**BART**

1451 7th St, Oakland,  
CA 94607

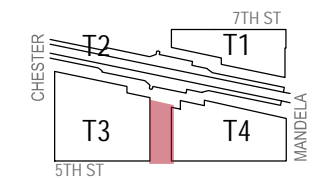

JRDV Architects, Inc  
The Cathedral Building  
Broadway and Telegraph  
PO Box 70126  
Oakland, CA 94612 USA  
510 295 4392 T  
www.jrdv.com



PROJ. # 168-153 WO BART

DATE: July 24, 2020

SHEET:

**CENTER  
SQUARE**

**A-9.18**



VIEW OF EXTERIOR STAIR



VIEW OF ART ALLEY FROM CENTER SQUARE



**MANDELA STATION**  
**@WEST OAKLAND**  
**BART**  
 1451 7th St, Oakland,  
 CA 94607

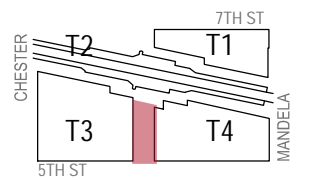

JRDV Architects, Inc  
 The Cathedral Building  
 Broadway and Telegraph  
 PO Box 70126  
 Oakland, CA 94612 USA  
 510 295 4392 T  
 www.jrdv.com



PROJ. # 168-153 WO BART

DATE: July 24, 2020

**CENTER SQUARE**

SHEET: **A-9.19**

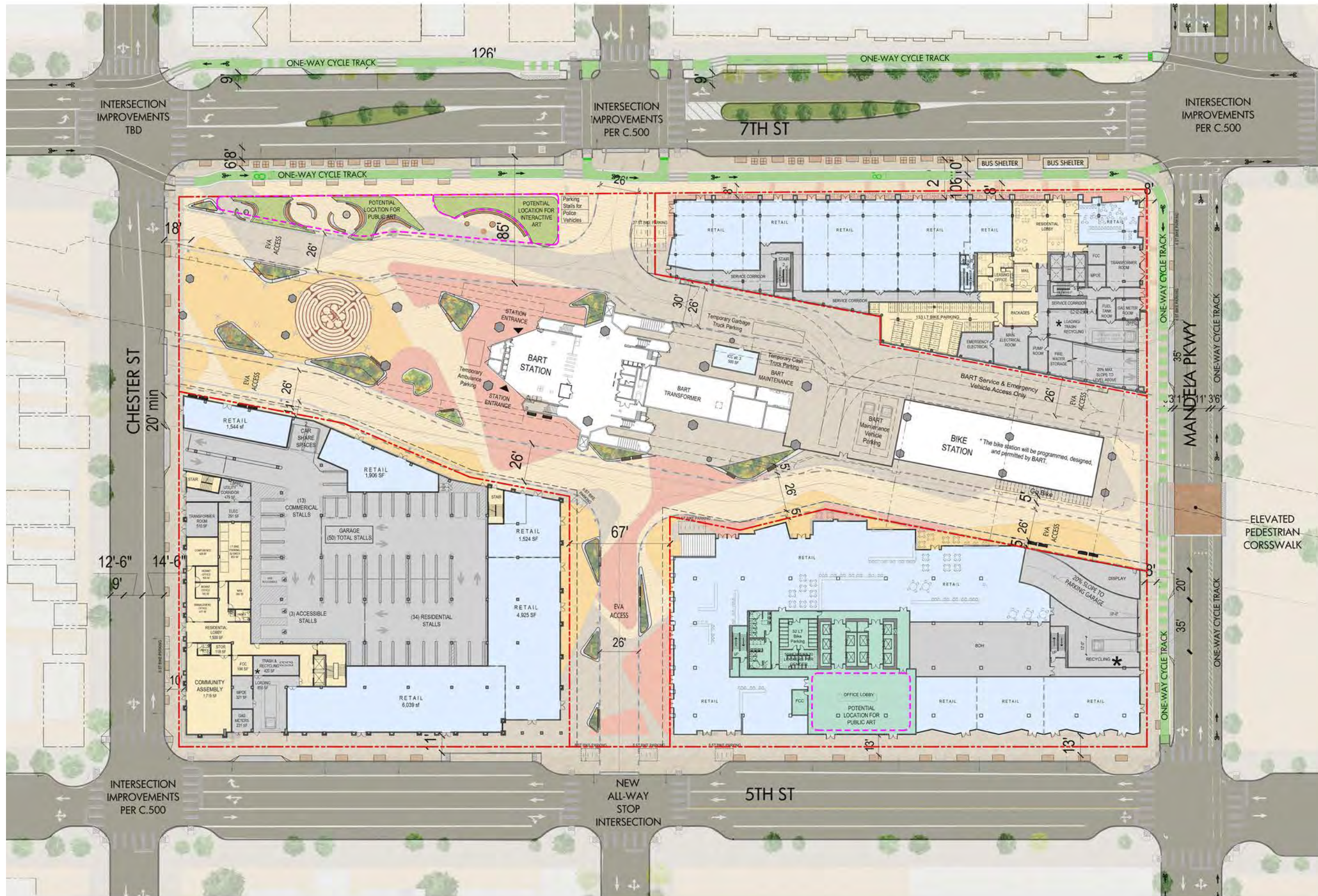

**MANDELA STATION  
 @WEST OAKLAND  
 BART**  
 1451 7th St, Oakland,  
 CA 94607

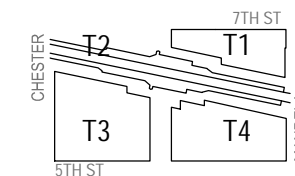

**JRDV URBAN  
 INTERNATIONAL**  
 JRDV Architects, Inc  
 The Cathedral Building  
 Broadway and Telegraph  
 PO Box 70126  
 Oakland, CA 94612 USA  
 510 295 4392 T  
 www.jrdv.com

**BKF100+  
 YEARS**  
 ENGINEERS, SURVEYORS, PLANNERS  
**stök**  
 PGAdesign  
 LANDSCAPE ARCHITECTS

PROJ. # 168-153 WO BART  
 DATE: July 24, 2020

**SITE PLAN**

SHEET:

**A-10.01**

The recycling space on T1 site is 1,150 cubic feet minimum, on T3 site is 510 cubic feet minimum, and on T4 site is 647 cubic feet minimum. The total recycling space on site is 2,307 cubic feet minimum.

\*The Hall of Fame Plaques will be removed from the right of way to be relocated back into the 7th Street right of way at an appropriate realigned location by the completion of T1.  
 \*The dancing lights will be removed from the right of way and there is no plan for their relocation as part of the FDP at this time.

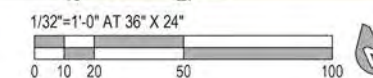

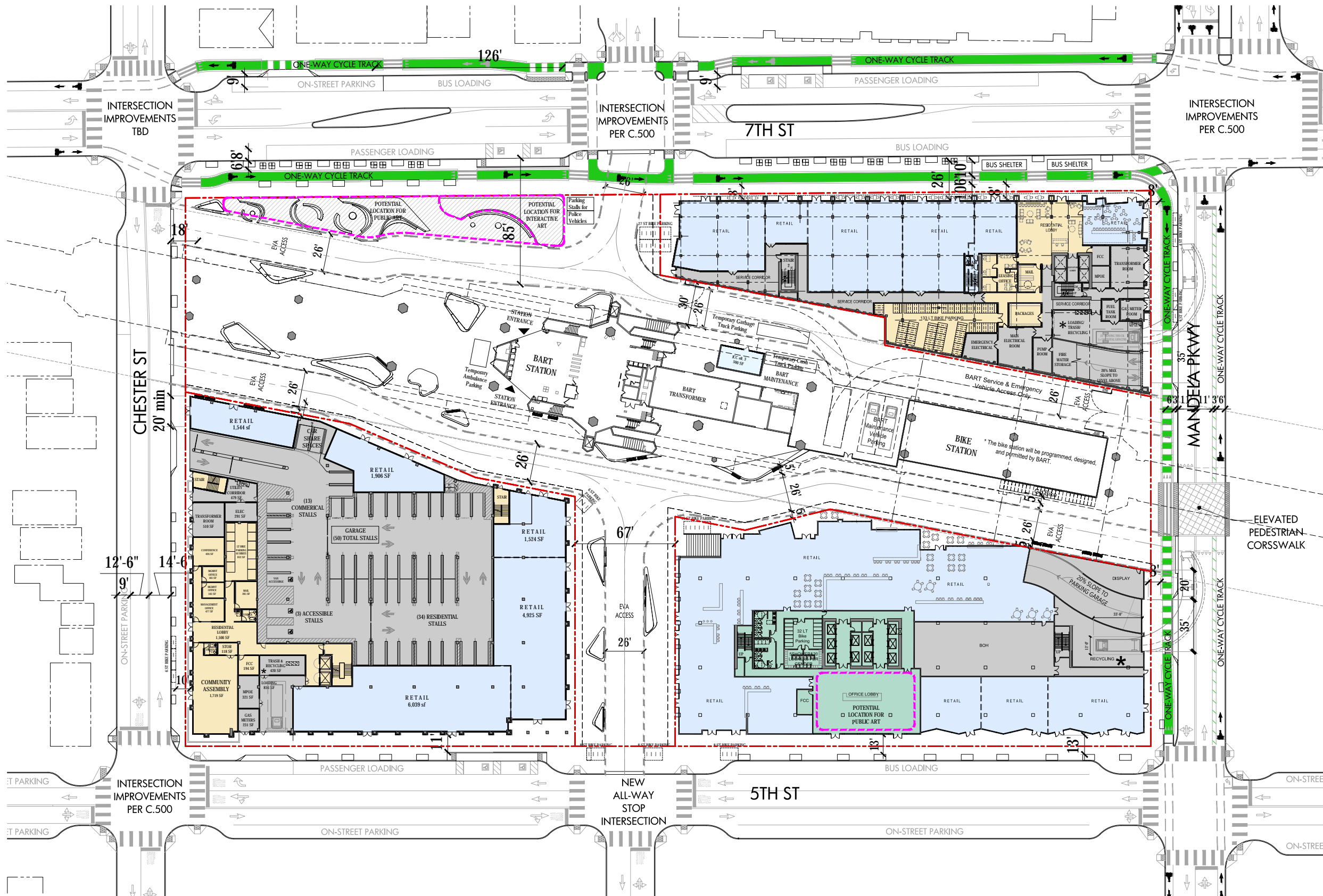

1. The recycling space on T1 site is 1,150 cubic feet minimum, on T3 site is 510 cubic feet minimum, and on T4 site is 647 cubic feet minimum. The total recycling space on site is 2,307 cubic feet minimum.

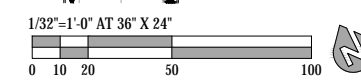

**MANDELA STATION**  
**@WEST OAKLAND**  
**BART**  
 1451 7th St, Oakland,  
 CA 94607

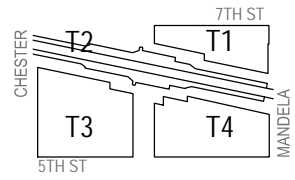

**JRDV URBAN**  
 INTERNATIONAL  
 JRDV Architects, Inc  
 The Cathedral Building  
 Broadway and Telegraph  
 PO Box 70126  
 Oakland, CA 94612 USA  
 510 295 4392 T  
 www.jrdv.com

**BKF100+**  
 YEARS  
 ENGINEERS, SURVEYORS, PLANNERS  
**stök**  
 PGAdesign  
 LANDSCAPE ARCHITECTS

PROJ. # 168-153 WO BART  
 DATE: July 24, 2020

**SITE PLAN**

SHEET:

# Crosswalks & Intersections

5th Street/Center Street and 5th Street/Chester Street Intersection: High-visibility crosswalks will be installed along with directional, ADA compliant curb ramps.

Chester Street/7th Street Intersection: To facilitate safe pedestrian, bicycle and vehicle movement, the curbs and crosswalks have been engineered to separate pedestrian and bicycle movements with clear non-conflicting pathways.

Bulb-outs have been provided where possible, including the NW, NE, and SW corners. Bus turning requirements prevent this on the SE corner.

Mandela Parkway/7th Street Intersection: This is a significant bike and pedestrian access point. To facilitate safe pedestrian, bicycle and vehicle movement, the curbs and crosswalks have been engineered to clearly separate pedestrian and bicycle movements with clear non-conflicting pathways. A dedicated bicycle signal phase will be evaluated for further consideration.

Mandela Parkway/5th Street Intersection: The NE, SE and SW crosswalks at this intersection have been bulbed out to minimize pedestrian crossing distances and ADA-compliant, directional curb ramps will be installed. Crosswalks will be reconfigured to create more directional connectivity.

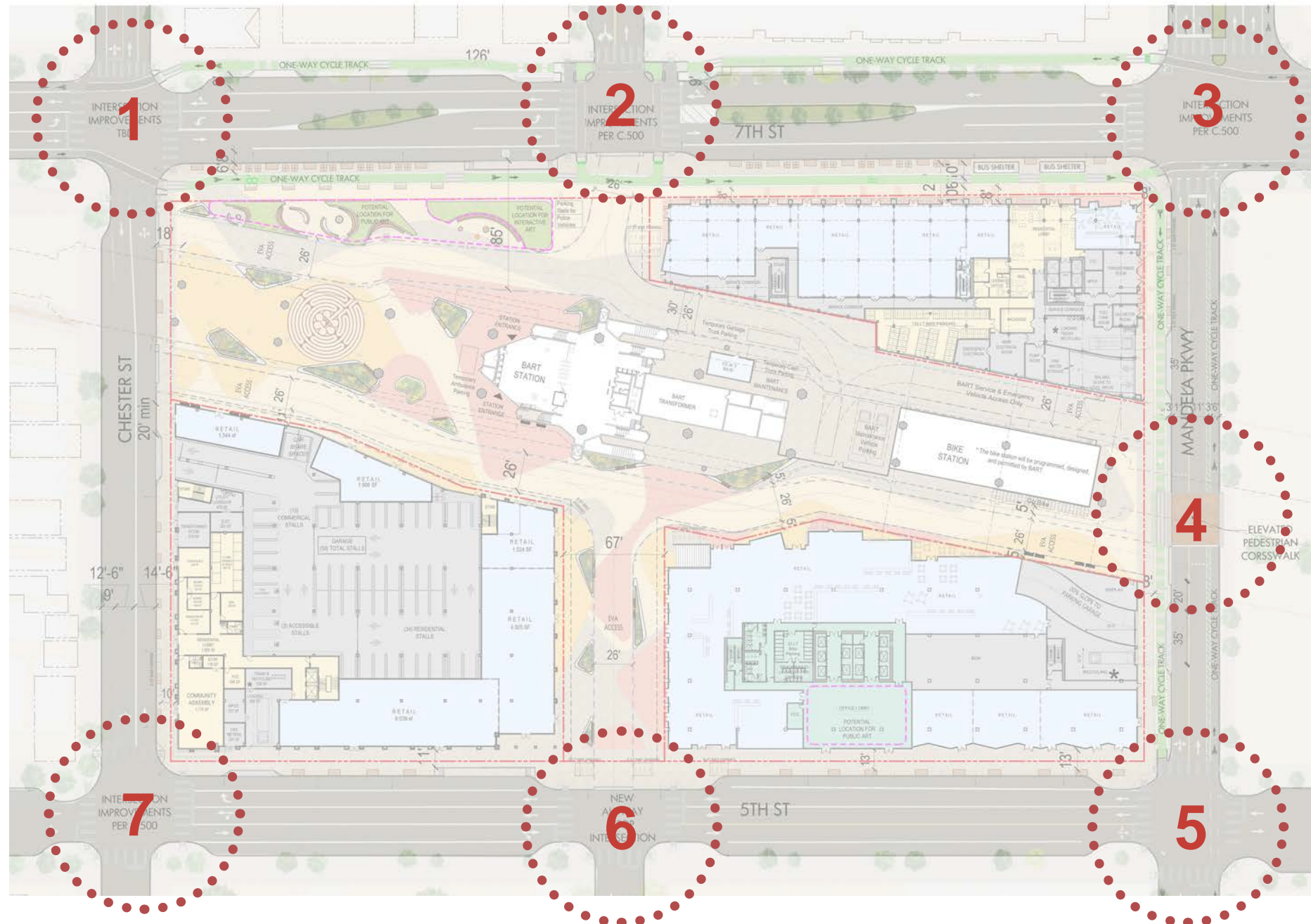

Mid-Block Crossing on Mandela: A high-visibility, mid-block pedestrian crossing will be added on Mandela Parkway between 7th and 5th Streets. The crossing design is raised and coordinated with the design of the two-way cycle track to facilitate safe pedestrian crossing of both the roadway and the cycle track.

7th Street/Center Street Intersection: The intersection crossing will be designed with a scramble pedestrian crossing to facilitate access. Bike and pedestrian access will be designed to prevent conflicts and promote ease of use. A protected intersection design will be provided with separated pedestrian crossing and bikeway crossing.

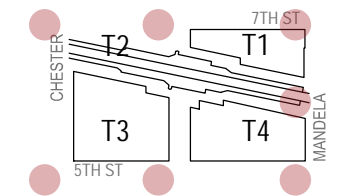

## 7TH STREET

8' SIDEWALK  
 6' CYCLE TRACK  
 +(2) 1' DET. BARRIERS  
 4' SIDEWALK  
 10' BUS LOADING  
 11.5' WESTBOUND  
 11' EASTBOUND  
 11.5' EASTBOUND  
 10' PASSENGER LOADING  
 8.5' SEPARATION  
 6' CYCLE TRACK  
 +(2) 1' DET. BARRIERS  
 8' SIDEWALK  
 PLAZA

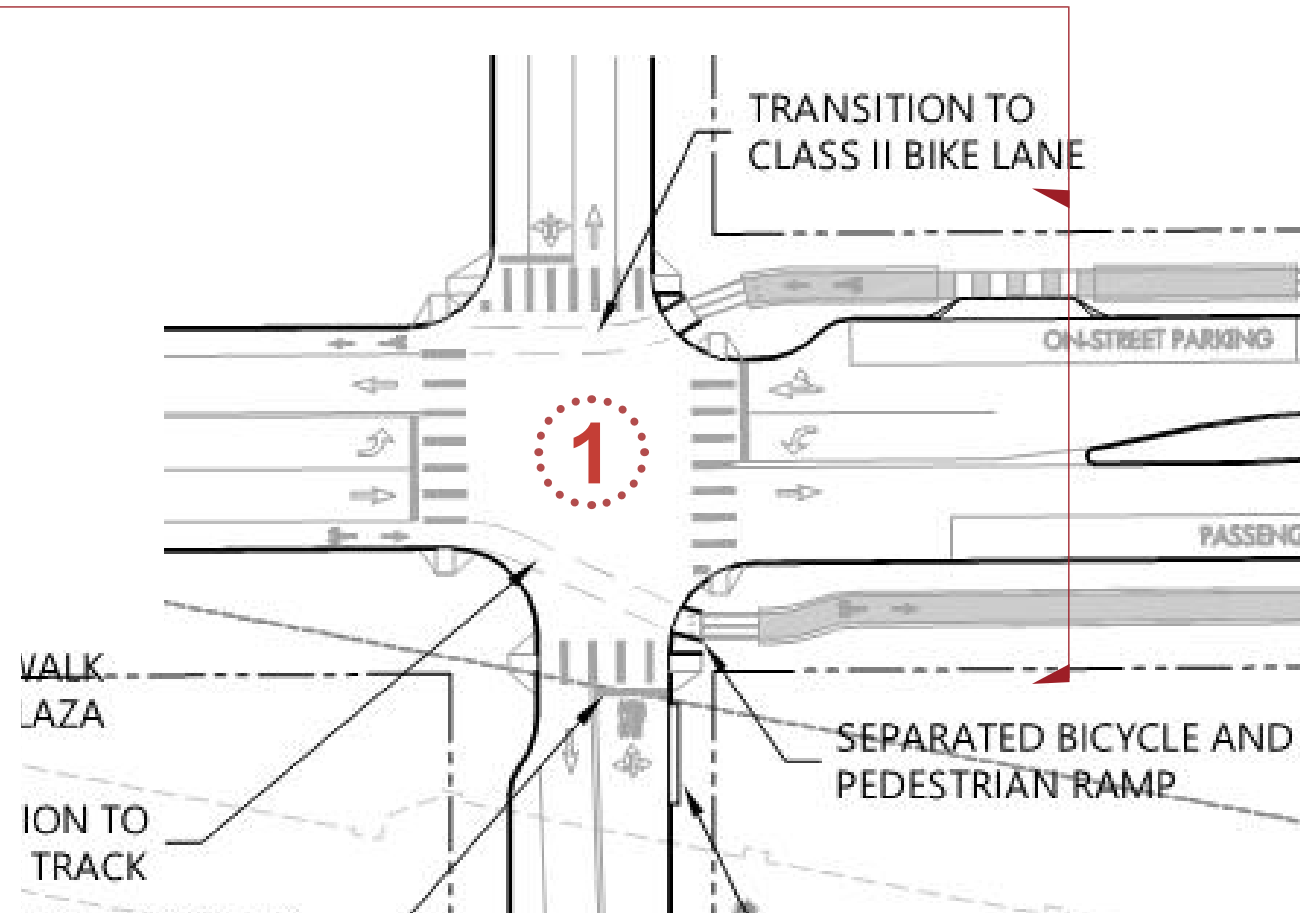

### RAMP NOTES:

1. BICYCLE AND PEDESTRIAN RAMPS SHALL BE SEPERATED.
2. DETECTABLE WARNING DOMES SHALL BE INSTALLED AT ALL RAMPS, SEE SHEET C5.03.



MANDELA STATION  
 @WEST OAKLAND  
 BART  
 1451 7th St, Oakland,  
 CA 94607

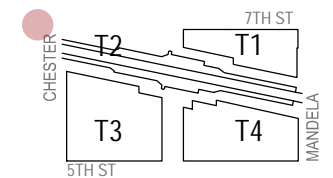

JRDV Architects, Inc  
 The Cathedral Building  
 Broadway and Telegraph  
 PO Box 70126  
 Oakland, CA 94612 USA  
 510 295 4392 T  
 www.jrdv.com



PROJ. # 168-153 WO BART  
 DATE: July 24, 2020

## CROSSWALKS & INTERSECTIONS

SHEET:

A-10.03.01



**MANDELA STATION**  
**@WEST OAKLAND**  
**BART**  
 1451 7th St, Oakland,  
 CA 94607

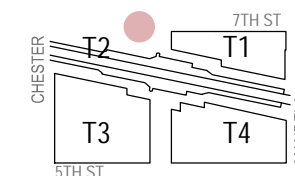

**6' ACCESSIBLE  
LOADING ZONE**

ADD SCRAMBLE PHASE TO  
SIGNALIZED INTERSECTION

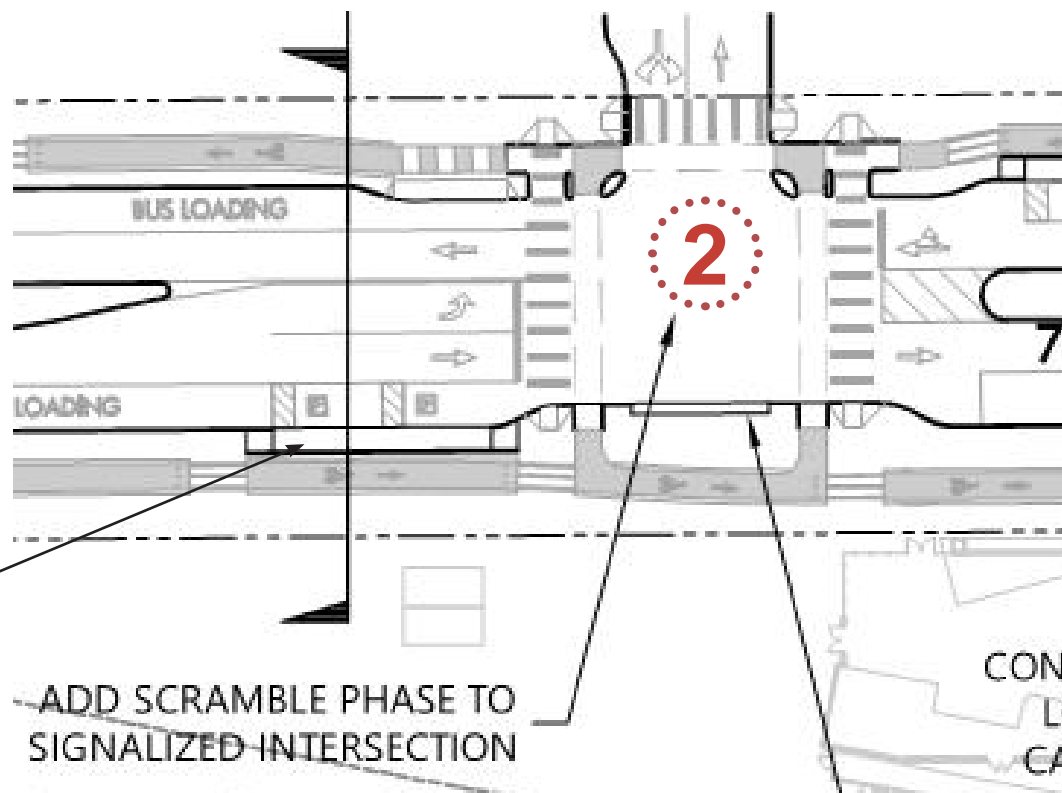

**RAMP NOTES:**

1. BICYCLE AND PEDESTRIAN RAMPS SHALL BE SEPERATED.
2. DETECTABLE WARNING DOMES SHALL BE INSTALLED AT ALL RAMPS, SEE SHEET C5.03.



JRDV Architects, Inc  
 The Cathedral Building  
 Broadway and Telegraph  
 PO Box 70126  
 Oakland, CA 94612 USA  
 510 295 4392 T  
 www.jrdv.com



PROJ. # 168-153 WO BART  
 DATE: July 24, 2020

**CROSSWALKS &  
INTERSECTIONS**

SHEET:

**A-10.03.02**



MANDELA STATION  
 @WEST OAKLAND  
 BART  
 1451 7th St, Oakland,  
 CA 94607

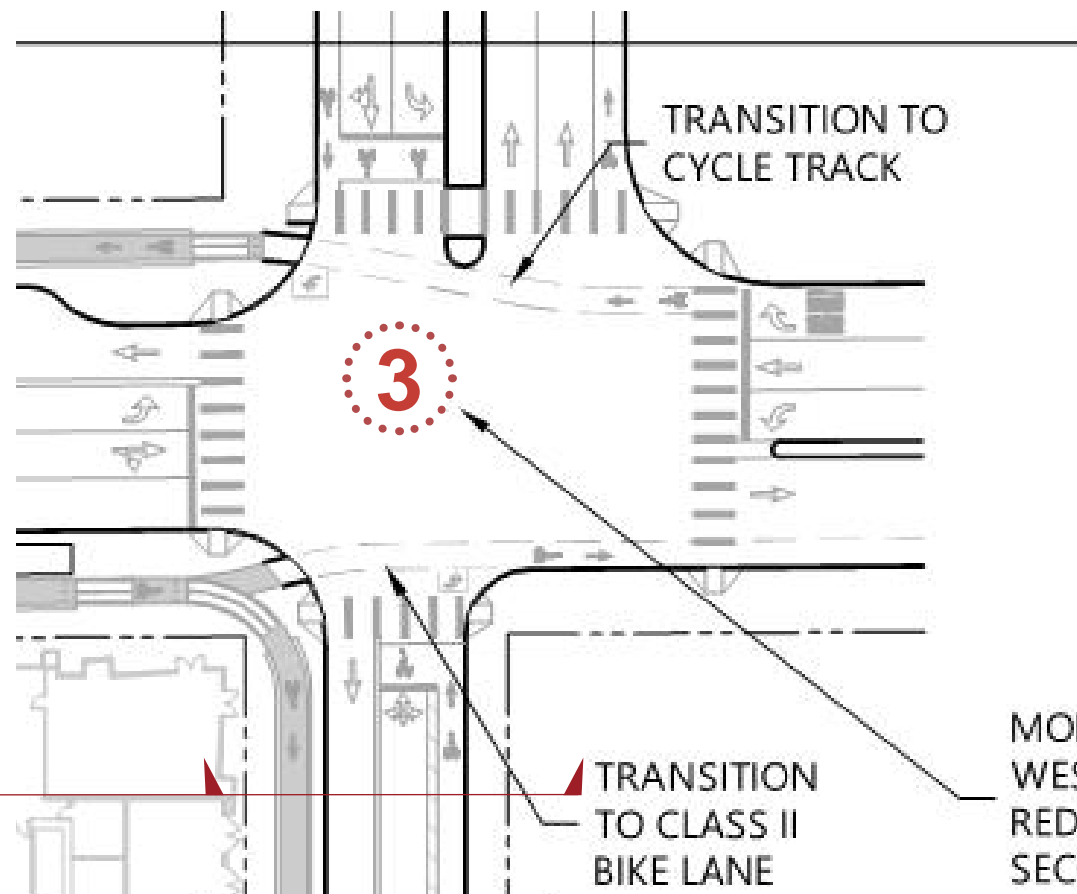
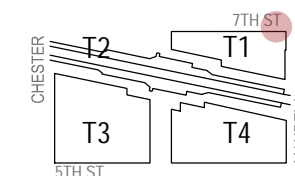

**MANDELA PARKWAY**

- 8' MIN. TO BUILDING
- 6' CYCLE TRACK
- +(2) 1' DET. BARRIERS
- 3.5' SIDEWALK
- 11.5' SOUTHBOUND
- 11.5' NORTHBOUND
- 2.5' BUFFER ZONE
- 6' BIKE LANE
- 10' SIDEWALK LANE

**RAMP NOTES:**

1. BICYCLE AND PEDESTRIAN RAMPS SHALL BE SEPERATED.
2. DETECTABLE WARNING DOMES SHALL BE INSTALLED AT ALL RAMPS, SEE SHEET C5.03.



JRDV Architects, Inc  
 The Cathedral Building  
 Broadway and Telegraph  
 PO Box 70126  
 Oakland, CA 94612 USA  
 510 295 4392 T  
 www.jrdv.com



PROJ. # 168-153 WO BART  
 DATE: July 24, 2020

**CROSSWALKS & INTERSECTIONS**

SHEET:

A-10.03.03





MANDELA STATION  
 @WEST OAKLAND  
 BART  
 1451 7th St, Oakland,  
 CA 94607

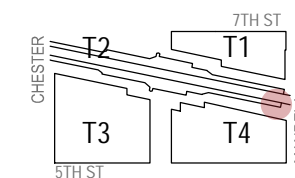

DETECTABLE WARNING  
 DOMES BOTH SIDES

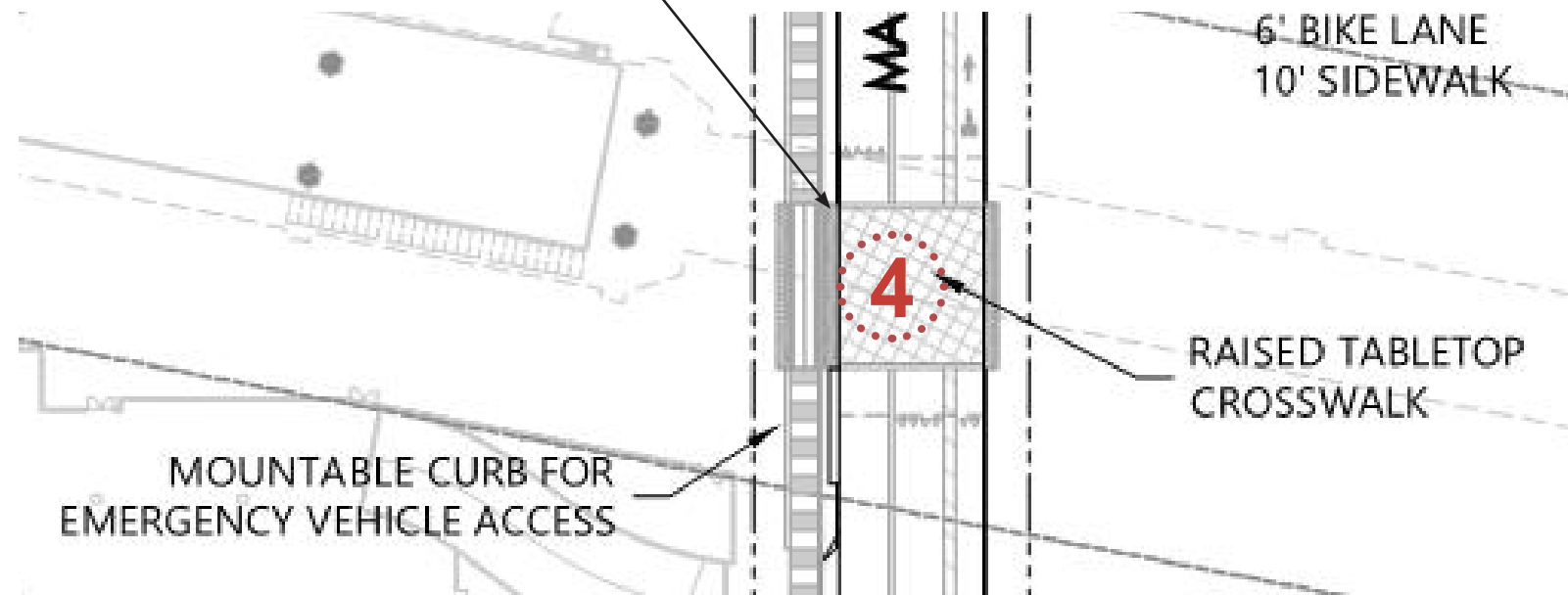

MOUNTABLE CURB FOR  
 EMERGENCY VEHICLE ACCESS

6' BIKE LANE  
 10' SIDEWALK

RAISED TABLETOP  
 CROSSWALK



JRDV Architects, Inc  
 The Cathedral Building  
 Broadway and Telegraph  
 PO Box 70126  
 Oakland, CA 94612 USA  
 510 295 4392 T  
 www.jrdv.com



PROJ. # 168-153 WO BART  
 DATE: July 24, 2020

CROSSWALKS &  
 INTERSECTIONS

SHEET:

A-10.03.04

**RAMP NOTES:**

1. BICYCLE AND PEDESTRIAN RAMPS SHALL BE SEPERATED.
2. DETECTABLE WARNING DOMES SHALL BE INSTALLED AT ALL RAMPS, SEE SHEET C5.03.



**MANDELA STATION  
@WEST OAKLAND  
BART**

1451 7th St, Oakland,  
CA 94607

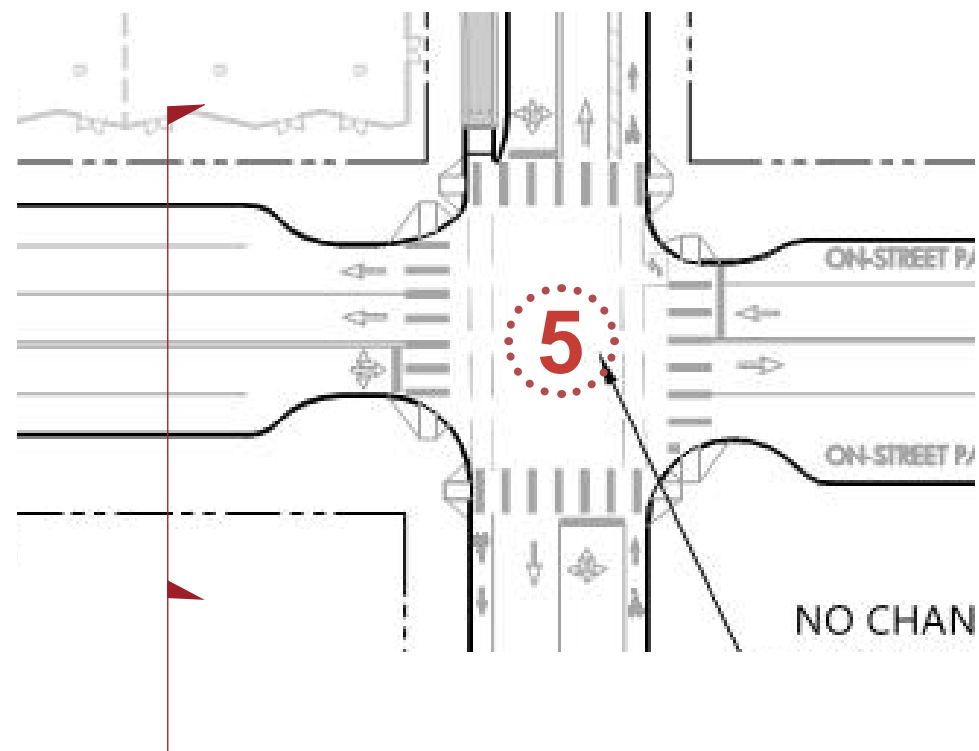
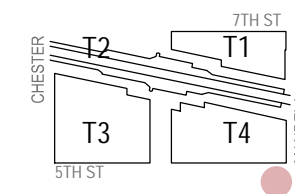

**5TH STREET**

- 10' SIDEWALK
- 9' BUS LOADING
- 11.5' WESTBOUND
- 11.5' WESTBOUND
- 11.5' EASTBOUND
- 9' ON-STREET PARKING
- 6' MIN SIDEWALK
- 12' TO PROPERTY LINE



**RAMP NOTES:**

1. BICYCLE AND PEDESTRIAN RAMPS SHALL BE SEPERATED.
2. DETECTABLE WARNING DOMES SHALL BE INSTALLED AT ALL RAMPS, SEE SHEET C5.03.

PROJ. # 168-153 WO BART

DATE: July 24, 2020

**CROSSWALKS &  
INTERSECTIONS**

SHEET:

A-10.03.05



**MANDELA STATION  
@WEST OAKLAND  
BART**  
1451 7th St, Oakland,  
CA 94607

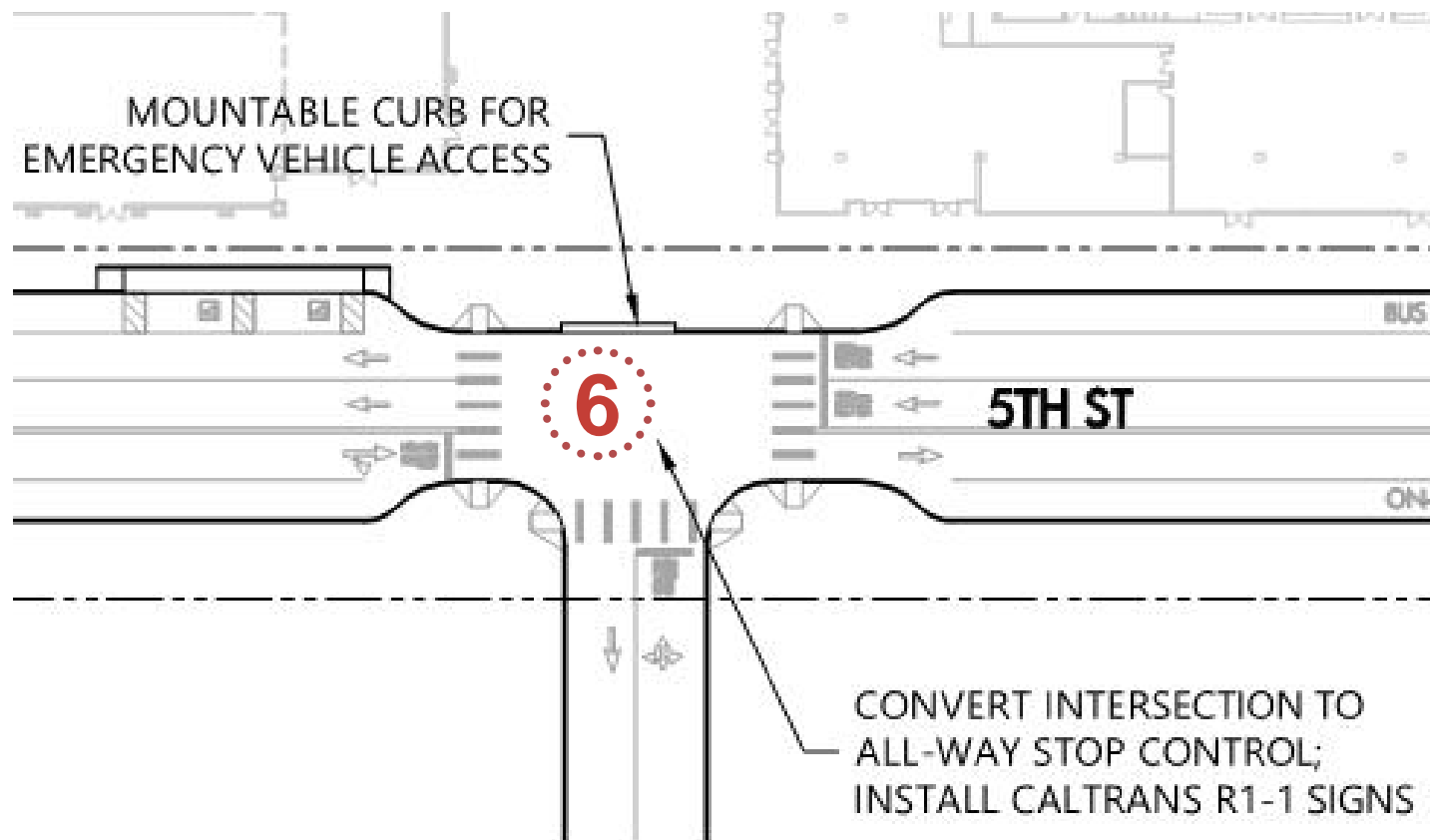
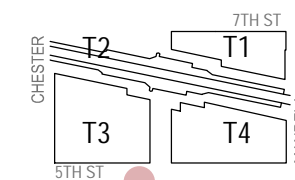

JRDV Architects, Inc  
The Cathedral Building  
Broadway and Telegraph  
PO Box 70126  
Oakland, CA 94612 USA  
510 295 4392 T  
www.jrdv.com



PROJ. # 168-153 WO BART  
DATE: July 24, 2020

## CROSSWALKS & INTERSECTIONS

SHEET:

A-10.03.06

### RAMP NOTES:

1. BICYCLE AND PEDESTRIAN RAMPS SHALL BE SEPERATED.
2. DETECTABLE WARNING DOMES SHALL BE INSTALLED AT ALL RAMPS, SEE SHEET C5.03.



**CHESTER STREET**

14' SIDEWALK

9' ON-STREET PARKING

12.5' SOUTHBOUND

14.5' NORTHBOUND

10' SIDEWALK

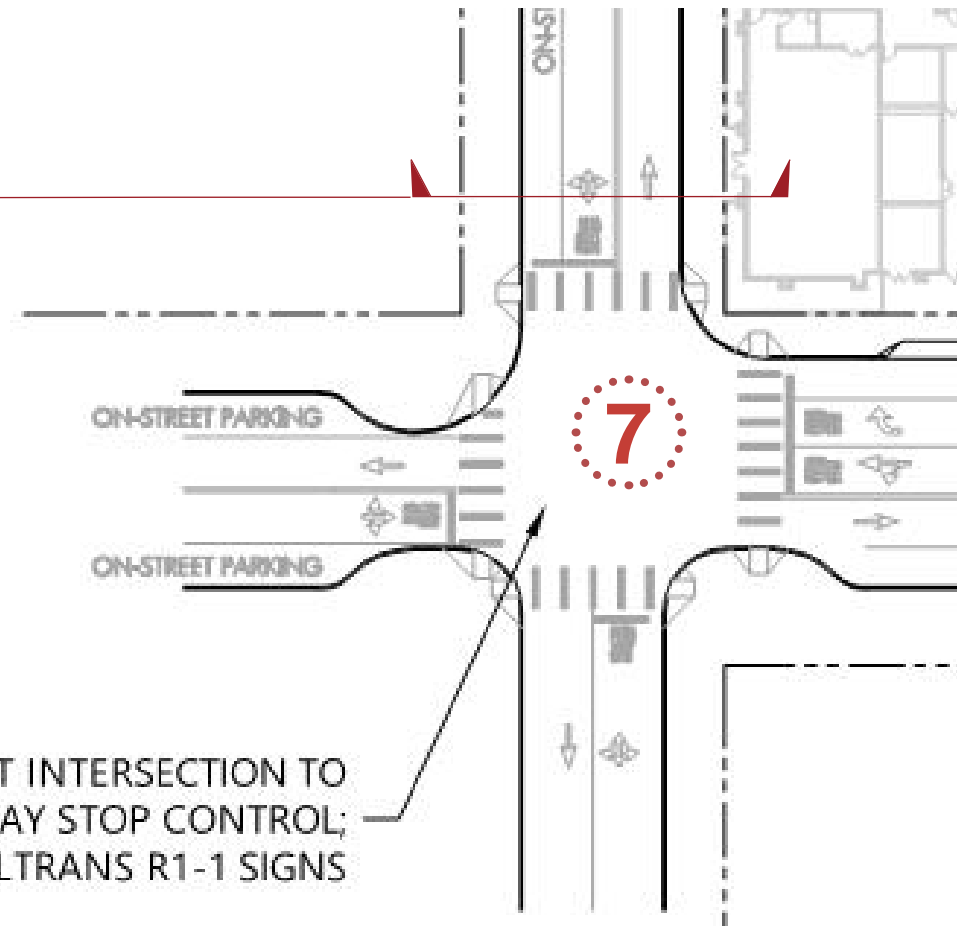

CONVERT INTERSECTION TO  
ALL-WAY STOP CONTROL;  
INSTALL CALTRANS R1-1 SIGNS

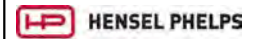

**MANDELA STATION  
@WEST OAKLAND**

**BART**

1451 7th St, Oakland,  
CA 94607

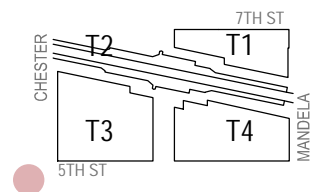

JRDV Architects, Inc  
The Cathedral Building  
Broadway and Telegraph  
PO Box 70126  
Oakland, CA 94612 USA  
510 295 4392 T  
www.jrdv.com



PROJ. # 168-153 WO BART

DATE: July 24, 2020

**CROSSWALKS &  
INTERSECTIONS**

SHEET:

A-10.03.07

**RAMP NOTES:**

1. BICYCLE AND PEDESTRIAN RAMPS SHALL BE SEPERATED.
2. DETECTABLE WARNING DOMES SHALL BE INSTALLED AT ALL RAMPS, SEE SHEET C5.03.



# Sidewalks

7th Street (between Mandela Parkway and Chester Street):

The sidewalk widths are range from 10'-15', and are designed to allow adequate clearances in order to accommodate the needs of pedestrians, bus passengers, and curbside passenger loading. The sidewalk is clear space for passanger loading at the curb, and a protected class 4 cycle track with clearly marked pedestrian crossing indicators.

Street lighting and street trees are located to reinforce the visual experience of the sidewalk space.

5th Street (between Mandela Parkway and Center Street):

The sidewalk width will be 10-15 feet min. wide in order to accommodate the needs of pedestrians, bus passengers, and curbside passenger loading.

5th Street (between Center and Chester Street):

Between 5th and 7th Streets, sidewalks adjacent to the project site are a minimum of 10 feet wide, and provide 8' clear path. The sidewalk is buffered from adjacent loading and street traffic by street pedestrian-scale lighting and street trees.

Chester Street Section  
3/L1.05

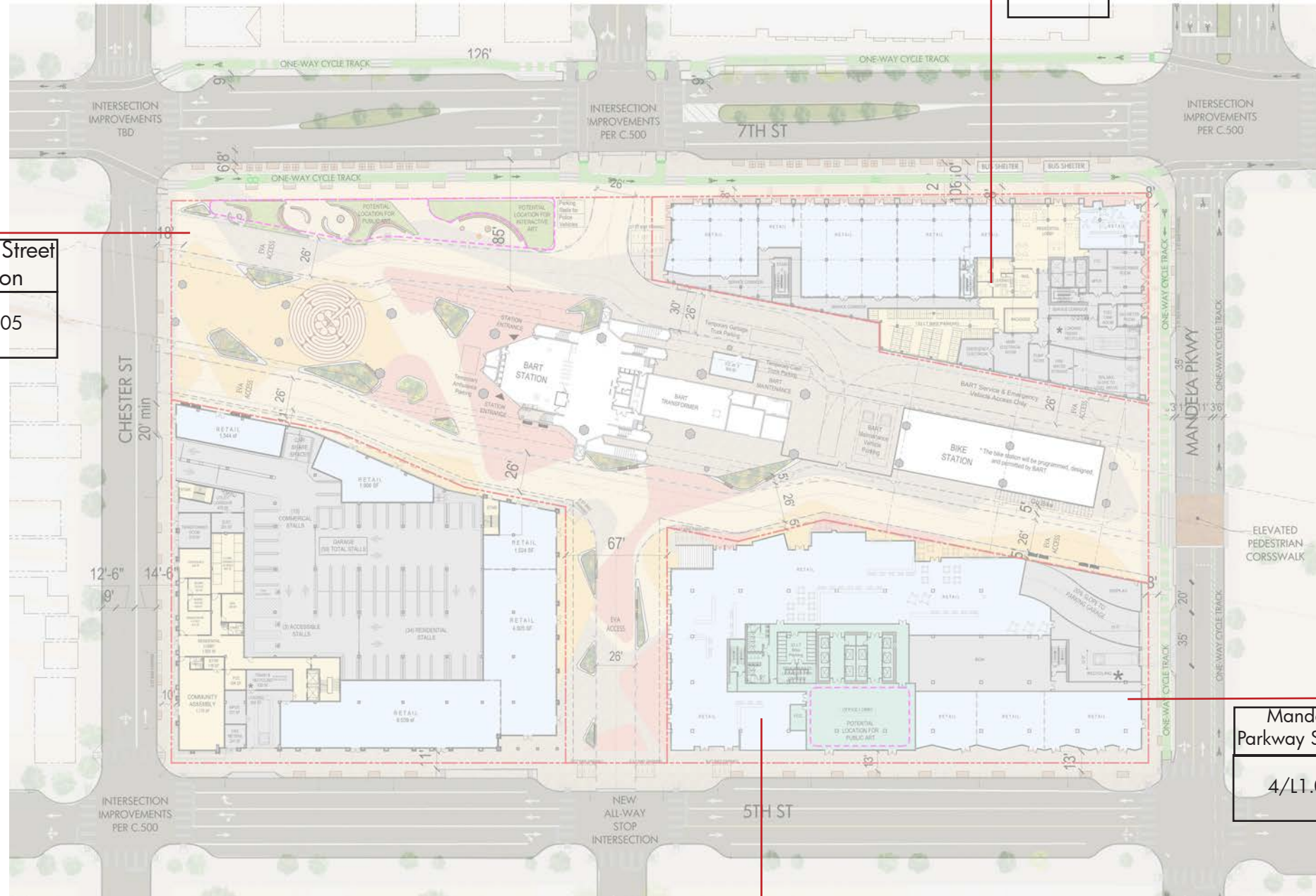

7th Street Section  
2/L1.05

Mandela Parkway Section  
4/L1.05

5th Street Section  
5/L1.05

Parking and Truck Loading Entrances: for the project are designed to provide clear sight lines, and include ADA features such as tactile warning strips, and audible warnings for when vehicles cross the pedestrian path of travel.

\*The developer will coordinate with the City of Oakland and the appropriate property owners, and document in the CMP prior to building permit, to determine the feasibility of and if deemed feasible, complete the sidewalk gap on the south side of 5th Street just east of Center Street.



**MANDELA STATION  
@WEST OAKLAND  
BART**  
1451 7th St, Oakland,  
CA 94607

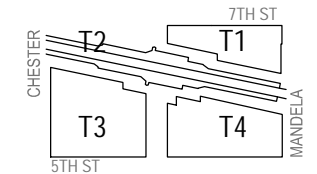

**JRDV URBAN  
INTERNATIONAL**  
JRDV Architects, Inc  
The Cathedral Building  
Broadway and Telegraph  
PO Box 70126  
Oakland, CA 94612 USA  
510 295 4392 T  
www.jrdv.com



PROJ. # 168-153 WO BART  
DATE: July 24, 2020

**PUBLIC SPACE  
IMPROVEMENT:  
SIDEWALKS**

SHEET:  
**A-10.04.01**

# Bikeways & Bike Parkings

## Mandela Cycle Tracks:

To facilitate bicycle access from the bicycle lanes on Mandela Parkway south of 7th Street and north of 5th Street, two raised, one-way cycle tracks are located along the west and east sides of Mandela Parkway between 7th and 5th Streets.

These one-way cycle tracks are 6 feet wide, with an 8' and 10' separation from face of curb to the edge of the cycle track. In addition to the cycle track, sidewalks with a minimum width of 8' clear are provided.

## 7th St Cycle Tracks Eastbound:

To facilitate bicycle access in conjunction with passenger loading from vehicles and buses along eastbound 7th Street between Chester Street and Mandela Parkway, a raised, one-way cycle track is provided.

The cycle track travel surface is 6 feet, with an 8'-10' foot setback from sidewalk to the face of curb.

## 7th St Cycle Tracks Westbound:

On westbound 7th Street between Mandela Parkway and Chester Street, a raised, one-way cycle track is located with a width of 6 feet.

The cycle track is provided an 8' setback sidewalk from the face of curb to the edge of the cycle track to provide adequate space for pedestrian loading.

Ford Go-bike: has been co-relocated with the Bike Station, to provide ease of access, prevent plaza use conflicts and to reinforce the bike station as a central hub for bike users.

\*The phasing of the bike station will be determined based on funding and construction phasing of the surrounding parcels; and will be documented within the Construction Management Plans. The phasing will likely follow completion of T1 and/or the completion of the adjacent EVA access routes; but, will be based on availability of grants and/or other funding.

\*Accommodating a pedestrian walkway and in-lane bicycle facility on 7th Street and Mandela Pkwy during the construction period of T1 may be accommodated, but it may require changes to the street lanes during construction which need to be studied by the developer and DOT and documented in the Construction Management Plan.

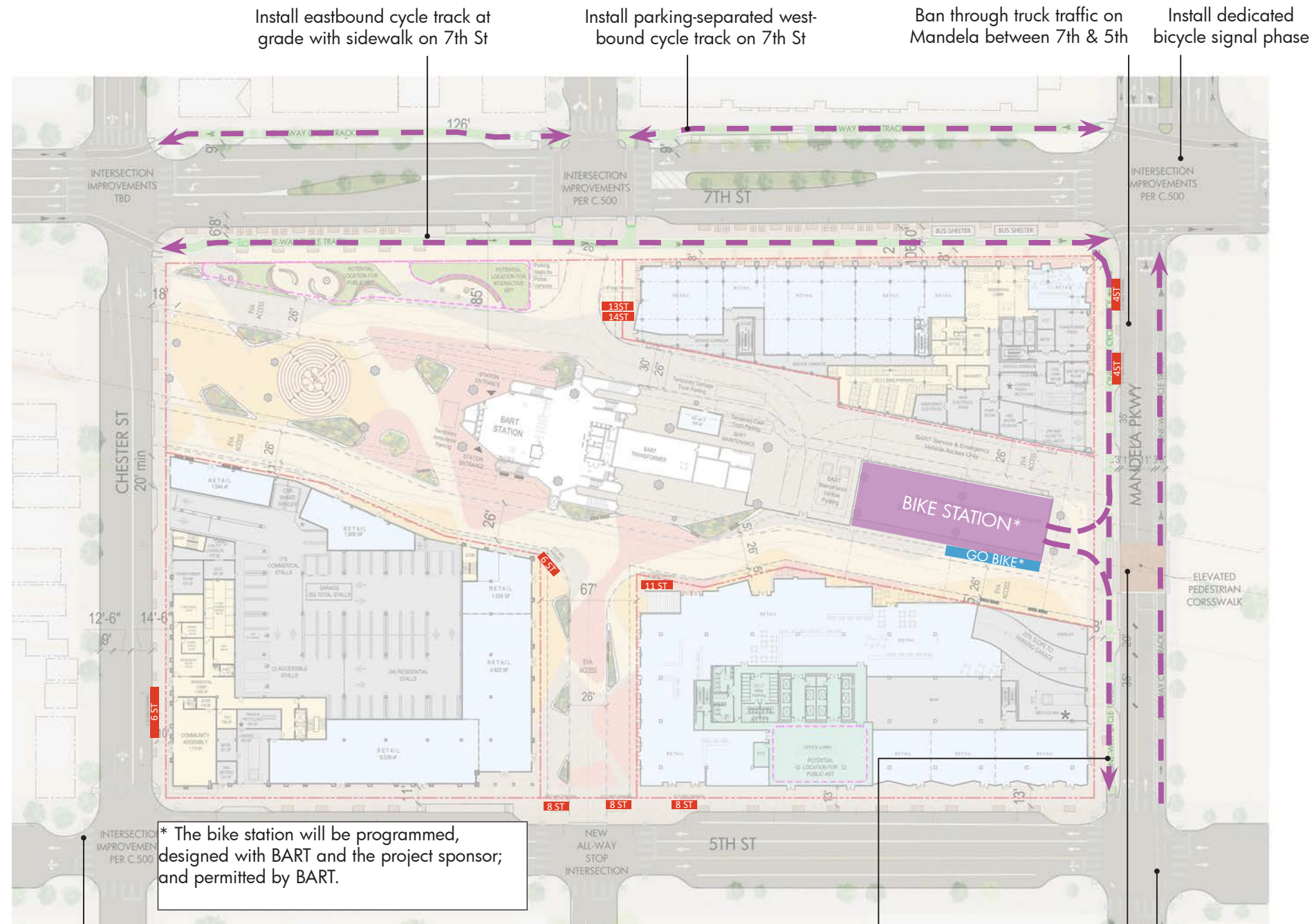

Install high-visibility crosswalks, directional curb ramps & pedestrian refuges on 5th St

Install 2 one-way cycle tracks on Mandela between 7th & 5th on grade with sidewalk

Install high-visibility mid-block crosswalk  
Install dedicated bicycle signal phase

## Bike Station:

The project will include an enhanced bicycle station located on the east side of the station structure. The bike station will be programmed, designed with BART and the project sponsor; and permitted by BART. The city will be responsible for design review.

Additional bicycle parking for BART and commercial patrons is provided throughout the site in the form of bicycle racks. Bicycle parking for the TOD's commercial and residential tenants will also be provided in accordance with City of Oakland requirements.

## Bike Parking Account:

**ON SITE SHORT TERM PARKING: 82**

**BIKE STATION:** The bike station will be programmed, designed with BART and the project sponsor; and permitted by BART. The city will be responsible for design review.

**GO BIKE PARKING NUMBER: 21**



## MANDELA STATION @ WEST OAKLAND

### BART

1451 7th St, Oakland, CA 94607

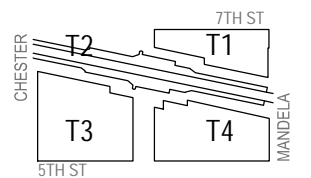

JRDV Architects, Inc  
The Cathedral Building  
Broadway and Telegraph  
PO Box 70126  
Oakland, CA 94612 USA  
510 295 4392 T  
www.jrdv.com



PROJ. # 168-153 WO BART

DATE: July 24, 2020

## PUBLIC SPACE IMPROVEMENT: BIKES

SHEET:

A-10.05

# Passenger Loading

## 7th Street Passenger Loading:

Will be located on the south side of 7th Street west of Center Street. A portion (50 linear feet) of this loading area closest to the intersection with Center Street is designated as a loading space for passengers with disabilities. This area provides the most direct access to the station entrance.

Another 200 feet of linear curb is on north side of 7th Street between Center Street and Mandela Parkway for passenger loading and unloading and 100 feet of linear curb near the Chester Street intersection.

## 5th Street Passenger Loading:

130 feet of linear curb is proposed along westbound 5th Street on the west side of the intersection with Center Street.

## Wayfinding:

Signage directing vehicles to loading zones will be provided at key decision points like the Mandela Parkway and 7th Street intersection and the 5th Street and Kirkham or Union Street intersections. Loading zone locations will be incorporated into smartphone mapping and TNC apps to facilitate safe and efficient circulation and access.

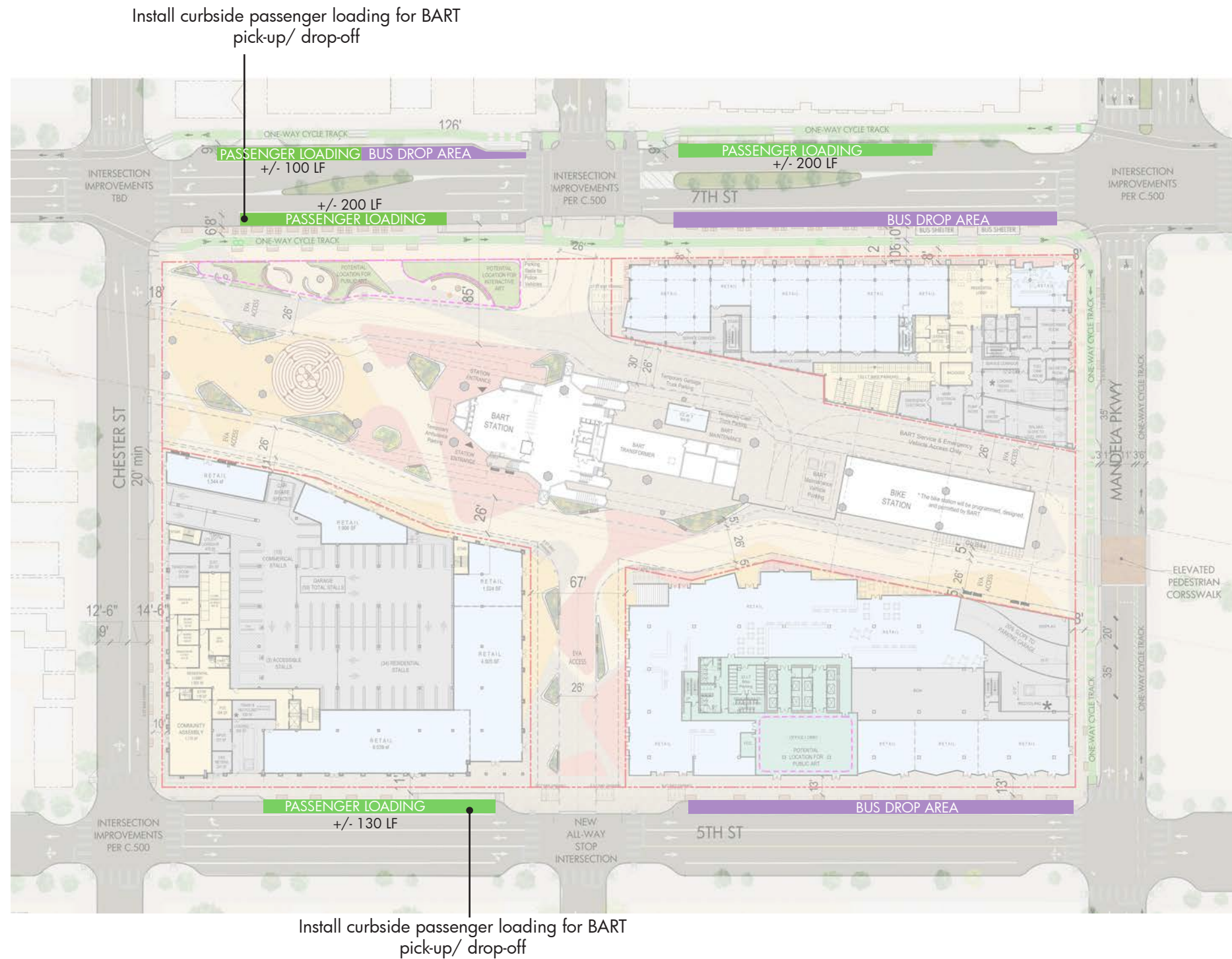

**MANDELA STATION  
@WEST OAKLAND  
BART**  
1451 7th St, Oakland,  
CA 94607

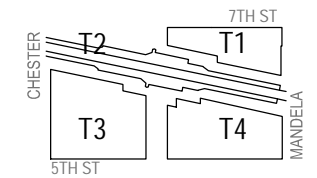

JRDV Architects, Inc  
The Cathedral Building  
Broadway and Telegraph  
PO Box 70126  
Oakland, CA 94612 USA  
510 295 4392 T  
www.jrdv.com



PROJ. # 168-153 WO BART

DATE: July 24, 2020

**PUBLIC SPACE  
IMPROVEMENT:  
PASSENGER  
LOADING**

SHEET:

A-10.06

# Bus Stops

Install bus stop for intercity coaches (Bolt, Megabus) - optional location east of Mandela

Install bus stop for line 29 and Emery-Go-Round

Start sidewalk taper immediately after cross-walk to better accommodate bus access

## 7th Street Eastbound:

The existing bus stop on eastbound 7th Street will be retained and extended to the intersection with Center Street for an approximate total length of 260 linear feet. This stop would serve AC Transit Lines 29, 36, and 62 and will serve as both a stop and layover space for AC Transit Line 14. If Emery-Go-Round service is extended to the West Oakland Station, this stop could serve Emery-Go-Round vehicles as well.

7th Street Westbound: A new bus stop will be installed on westbound 7th Street to serve AC Transit Line 29 and Emery-Go-Round, if the service is extended to the West Oakland Station. 90 feet of linear curb is provided at this location to accommodate transit vehicles, as well as a concrete bus pad in the roadway.

5th Street Westbound: The bus stop and layover for lines 36 and 62 will be relocated to westbound 5th Street on the far side of the intersection with Mandela Parkway. 235 feet of curb length is provided to accommodate the bus stop and layovers, and a concrete bus pad will be installed in the roadway.

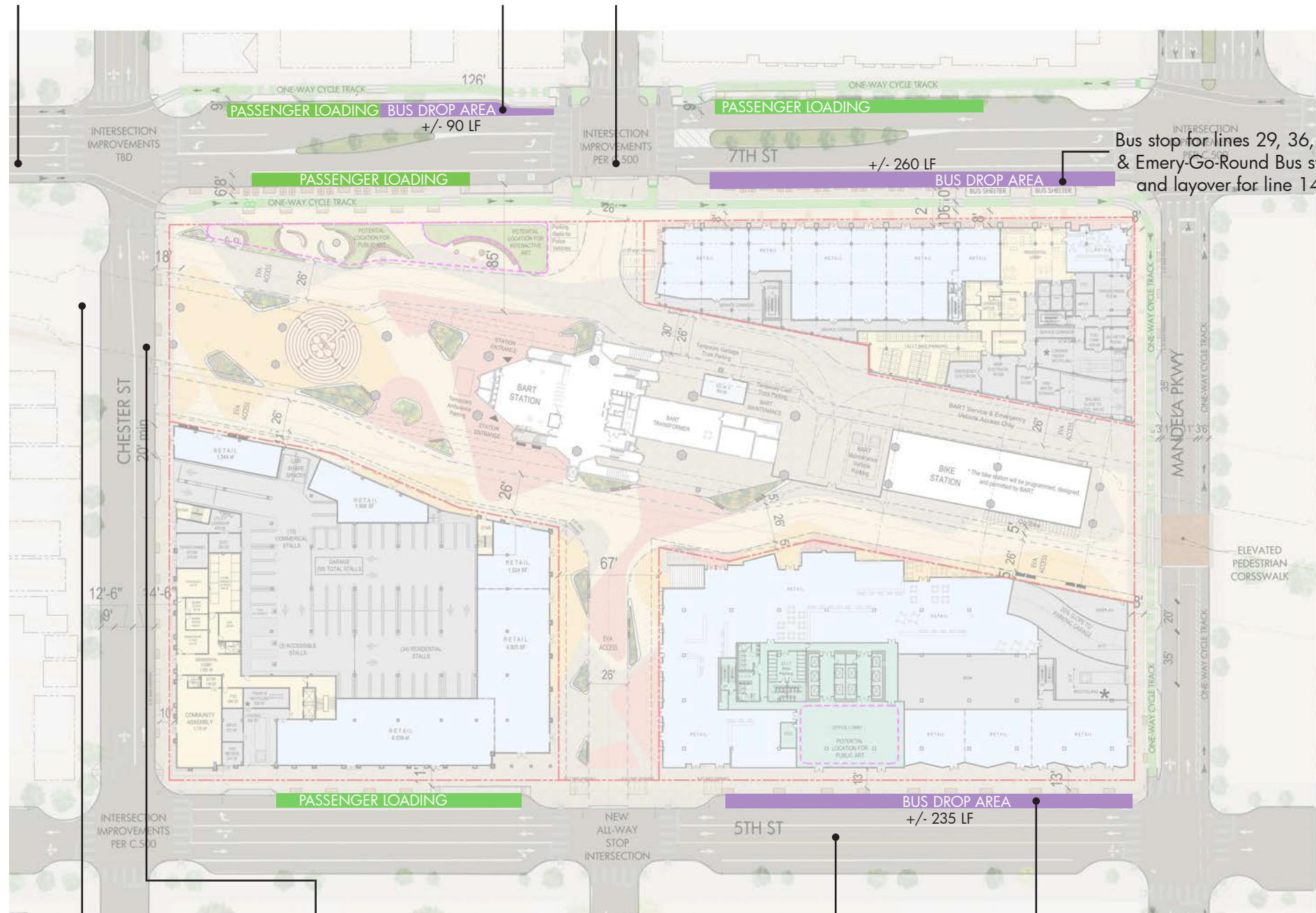

Potential layover space for lines 36 & 62, requires further evaluation

Redesign Chester St cross-section to facilitate buses turning right

Install median barrier to prevent jaywalking to/from bus stop

Bus stop and layover for lines 62 & 36

**Intercity & Private Bus Stops:** A bus stop for intercity coaches (e.g., Megabus and Bolt) could be installed on 7th Street between Henry and Chester Streets. Private employer shuttle could also utilize this stop. The existing BART surface parking immediately adjacent to this curb could be utilized for bus and shuttle transit passenger pick-up and drop-off (if not utilized as a layover space for AC Transit buses). A option to locate this bus stop east of Mandela Parkway is under consideration.

**Passenger Amenities:** All bus stops are provide with a high level of passenger amenities, including shelters with seating, maps and other information, and real-time bus arrival information; trash receptacles; and lighting.

\*The developer will work with the City to designate a bus stop for intercity coaches (e.g., Megabus and Bolt) and other shuttles on 7th Street between Henry and Chester Streets.



**MANDELA STATION  
@WEST OAKLAND**  
BART  
1451 7th St, Oakland,  
CA 94607

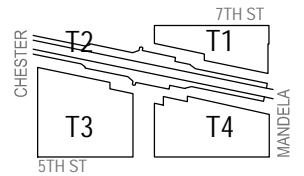

JRDV Architects, Inc  
The Cathedral Building  
Broadway and Telegraph  
PO Box 70126  
Oakland, CA 94612 USA  
510 295 4392 T  
www.jrdv.com



PROJ. # 168-153 WO BART

DATE: July 24, 2020

## PUBLIC SPACE IMPROVEMENT: BUS STOPS

SHEET:



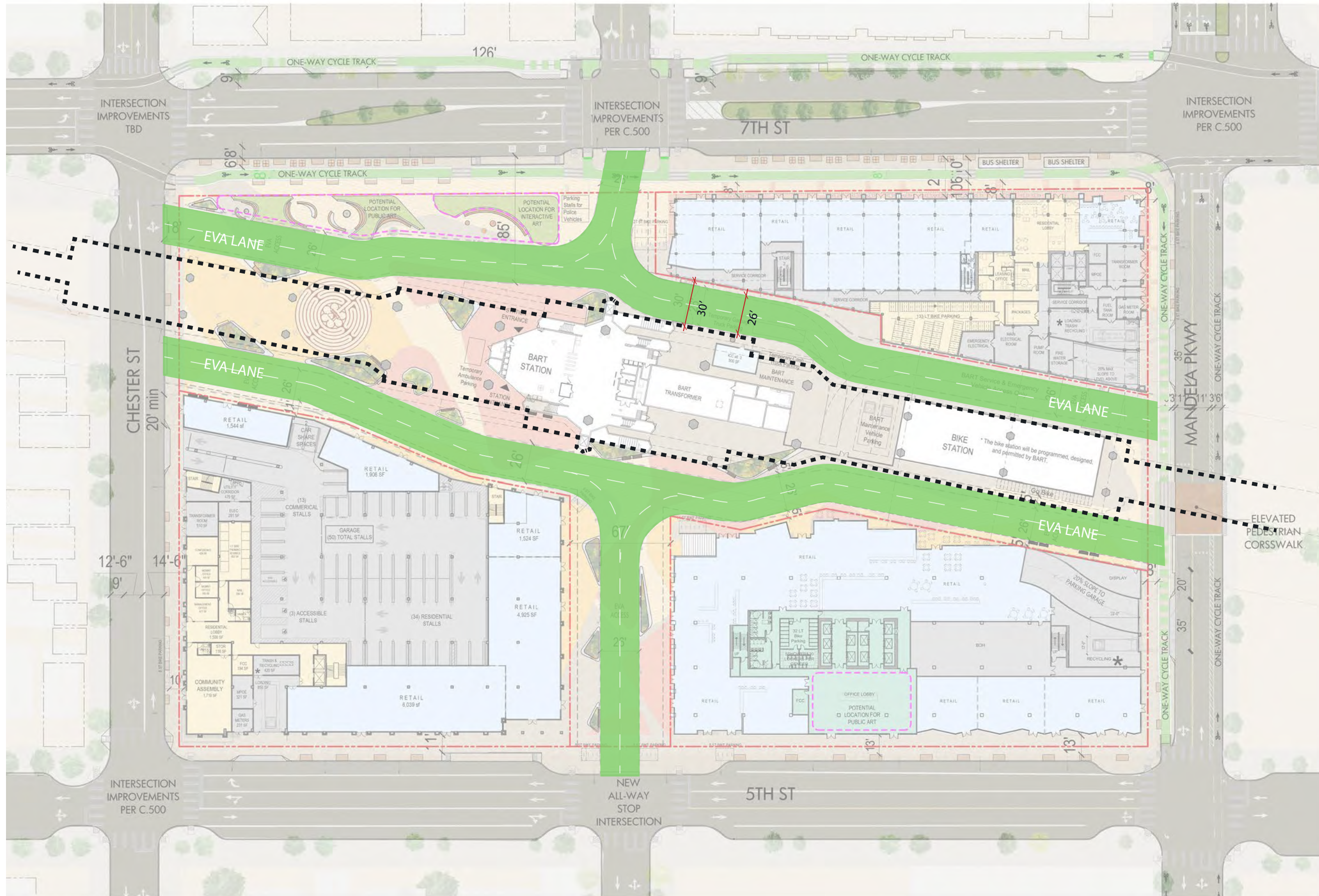

The recycling space on T1 site is 1,150 cubic feet minimum, on T3 site is 510 cubic feet minimum, and on T4 site is 647 cubic feet minimum. The total recycling space on site is 2,307 cubic feet minimum.

\* For detail about the gates for EVA, please refer to drawing A-60.01.



**MANDELA STATION**  
**@WEST OAKLAND**  
**BART**  
 1451 7th St, Oakland,  
 CA 94607

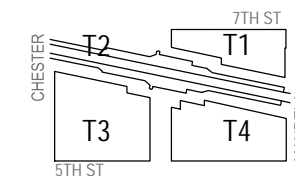

PROJ. # 168-153 WO BART  
 DATE: July 24, 2020

**EMERGENCY**  
**VEHICLE**  
**ACCESS**

SHEET:

**A-10.08**

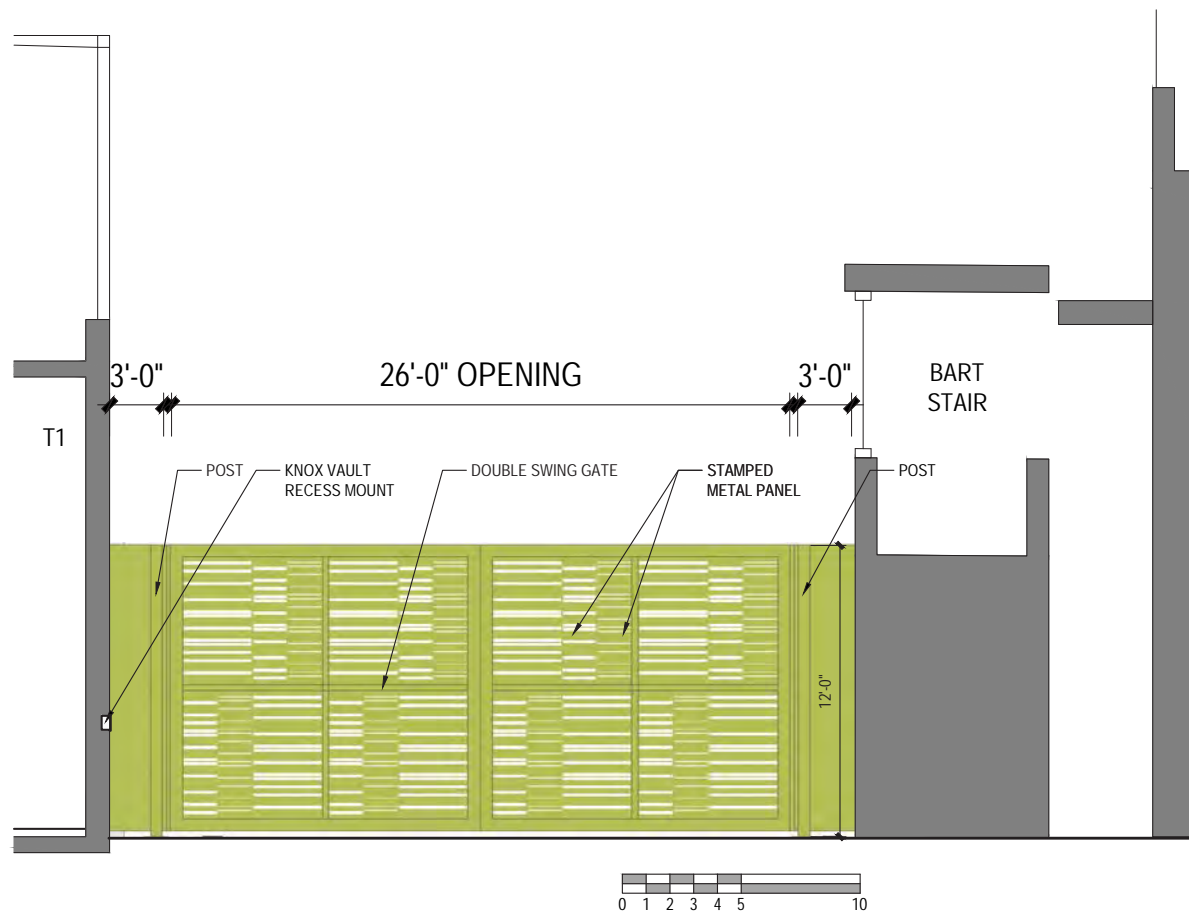

① EVA ROUATE WEST GATE  
1/4" = 1' - 0"

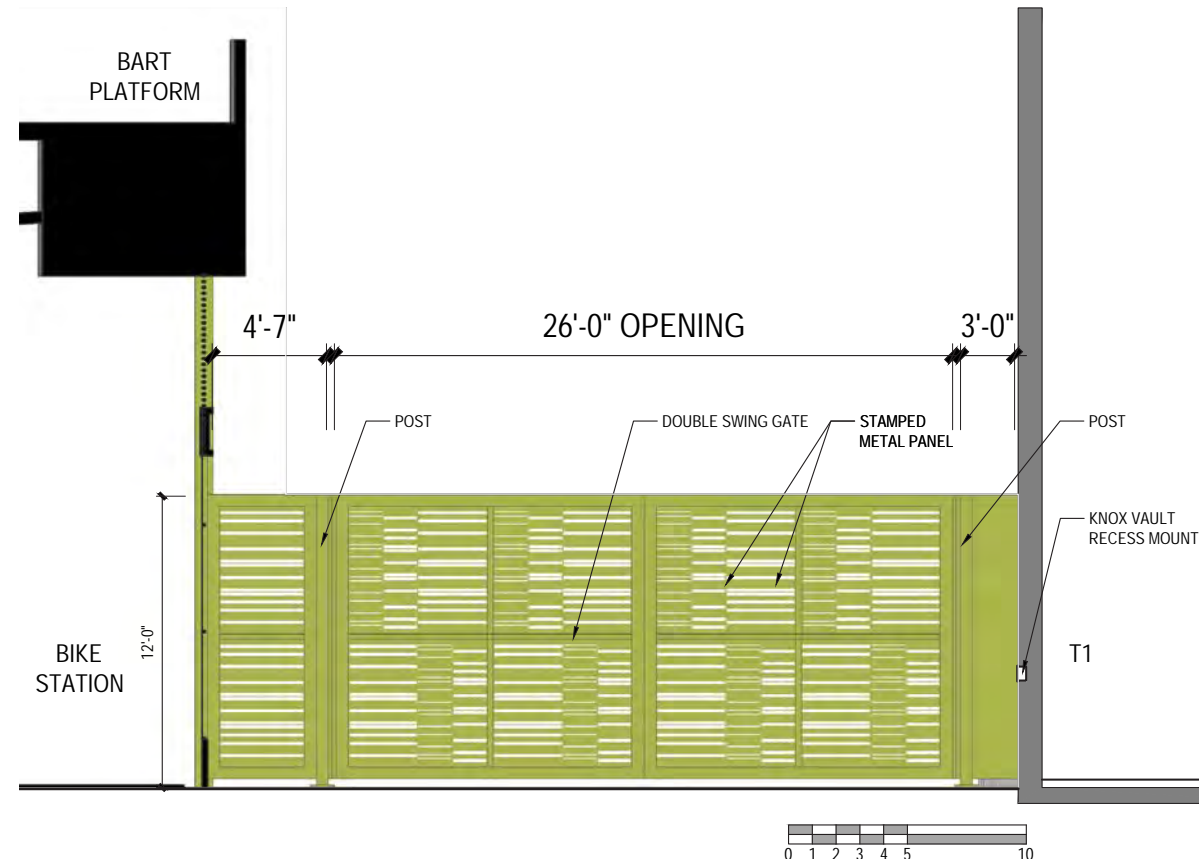

② EVA ROUATE EAST GATE  
1/4" = 1' - 0"

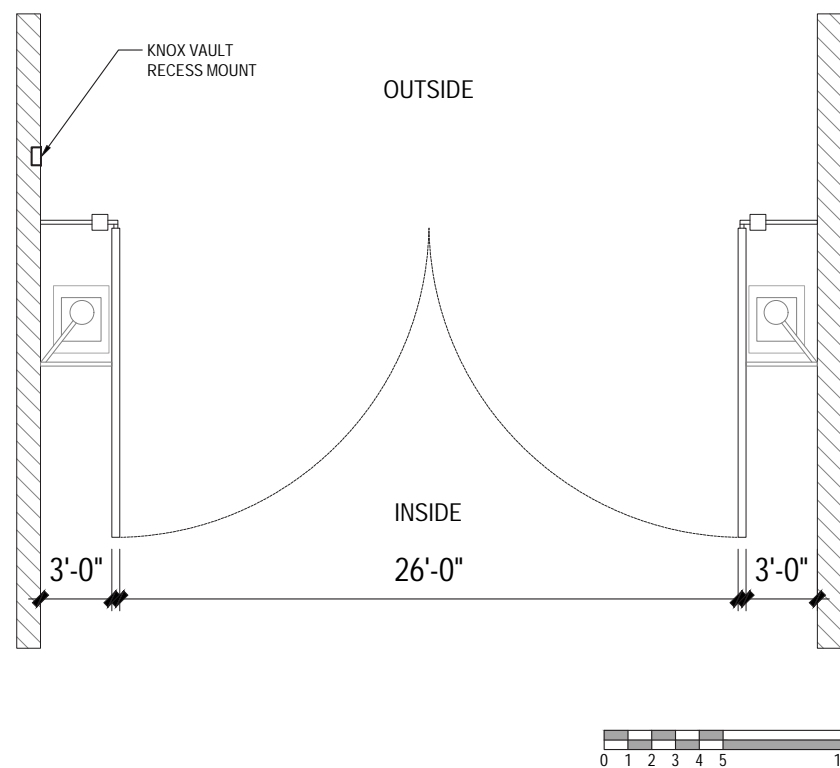

③ TYPICAL EVA ROUATE ENTRANCE PLAN  
1/4" = 1' - 0"



MANDELA STATION  
@WEST OAKLAND  
BART  
1451 7th St, Oakland,  
CA 94607

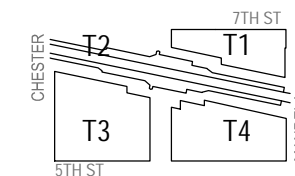

JRDV Architects, Inc  
The Cathedral Building  
Broadway and Telegraph  
PO Box 70126  
Oakland, CA 94612 USA  
510 295 4392 T  
www.jrdv.com



PROJ. # 168-153 WO BART  
DATE: July 24, 2020

EVA GATE  
DETAIL

SHEET:

A-60.01

**ATTACHMENT G:**

**Proposed T3 Final Development Plan, dated September 16,  
2020**

# MANDELA STATION

@ West Oakland BART

## FINAL DEVELOPMENT PLAN T3

July 24, 2020

Amended September 16, 2020



**GENERAL**

G100	TITLE SHEET, DRAWING INDEX
A-00.01 -	RENDERINGS
A-00.14 -	

**CONTEXT INFO**

A-01.01	ZONING INFO
A-01.02	OPEN SPACE ANALYSIS
A-01.03	ZONING SUMMARY
A-01.04	PHASING PLAN
A-01.05	GREENPOINT RATED
A-01.06	CONTEXT MAP
A-01.07	CONTEXT PHOTOS
A-01.08	CONTEXT VIEW
A-01.09	CONTEXT VIEW

**CIVIL PLANS**

C1.00	EXISTING CONDITIONS PLAN
180384 1-5	TOPOGRAPHIC AND BOUNDARY SURVEY
C-1.01A -	TENTATIVE PARCEL MAP
C-1.01C	
C1.02	LOT MERGER PLAN
C2.00	PROPOSED GRADING PLAN
C3.00	STORMWATER MANAGEMENT PLAN
C4.00	EROSION CONTROL PLAN
C4.01	EROSION CONTROL PLAN DETAILS

**LANDSCAPE PLANS**

L1.00	TREE REMOVAL PLAN
L1.01	LAYOUT & MATERIALS PLAN
L1.01.02	PUBLIC ACCESS PLAN
L1.02	LANDSCAPE WALL HEIGHT PLAN
L1.03	LANDSCAPE SECTIONS
L1.04	LANDSCAPE SECTIONS
L1.05	STREET SECTIONS
L1.06	PRELIMINARY LIGHTING PLAN
L1.07	PLANTING ZONES
L1.08	LANDSCAPE PLANTS
L1.09	LANDSCAPE MATERIALS
L1.10	LIGHTING IMAGES
L1.11	LIGHT LEVEL GOALS
L1.13	PODIUM LAYOUT PLAN T3
L1.14	PODIUM PALETTE T1
L-00.12	LANDSCAPE VIEWS

**ARCHITECTURAL PLANS, ELEVATIONS, AND DETAILS**

A-9.01	UNDER TRACK STRATEGY
A-9.02	UNDER TRACK REFERENCE
A-9.03	EVENT SPACE PROGRAM
A-9.04	MASSING CONCEPT
A-9.05	7TH ELEV. CONCEPT
A-9.06	ARTWALK ELEVATION CONCEPT
A-9.07	CENTER SQUARE ELEVATION CONCEPT
A-9.08	MASSING DIAGRAM
A-9.09	UNIT MIX
A-9.10	MATERIAL PALETTE
A53.01	TYPICAL WALL & WINDOW SECTION 1
A53.02	TYPICAL WALL & WINDOW SECTION 2
A10.01	SITE PLAN
A13.01	T3 GROUND FLOOR PLAN
A13.02	T3 2ND FLOOR PLAN
A13.03	T3 3RD FLOOR PLAN
A13.04	T3 4-7TH FLOOR PLAN
A13.05	T3 9TH ROOF PLAN
A23.01	T3 SOUTH ELEVATION
A23.02	T3 EAST ELEVATION
A23.03	T3 NORTH ELEVATION
A-23.03.01	PUBLIC ART REFERENCES - ART EXHIBITION WALL
A23.04	T3 WEST ELEVATION
A33.01	SECTION A-A
A33.02	SECTION B-B



T3 RESIDENTIAL

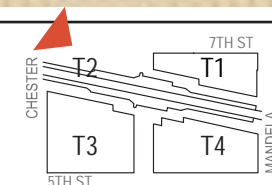



T3 RESIDENTIAL

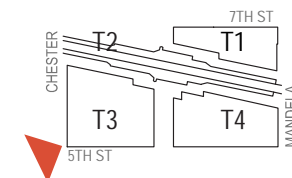

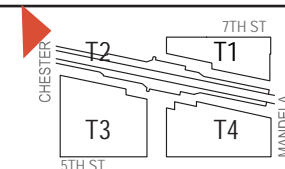



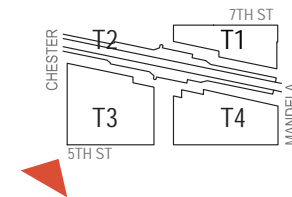

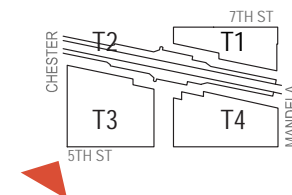

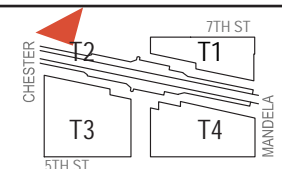

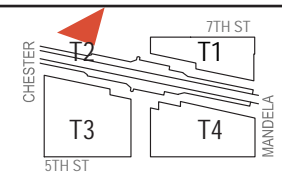

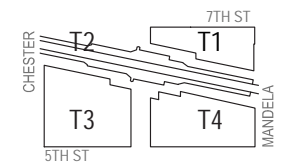

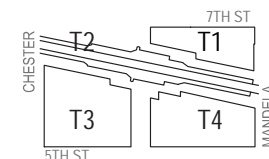



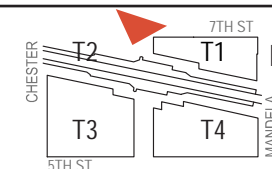



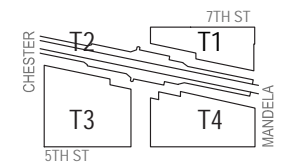

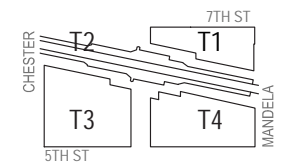

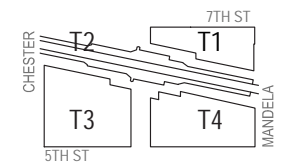

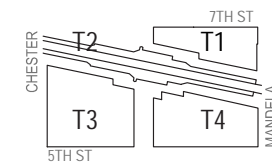

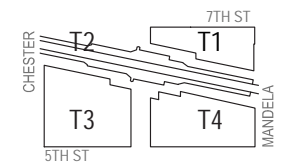

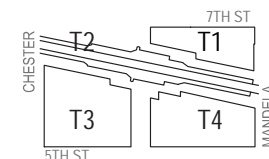

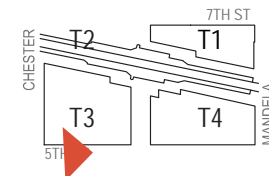

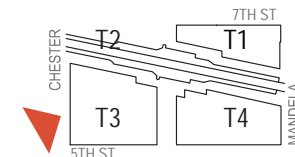



**Proposed Program**

USES	T1	T2	T3	T4	Program Total
OFFICE				300,000 sf	300,000 sf
RETAIL	14,350 sf	Flexible Kiosk Program	15,944 sf	23,184 sf	53,478 sf
OTHER NON-RESIDENTIAL			2,057 sf	8,540 sf	10,597 sf
RESIDENTIAL	522 units		240 units*		762 units (20% min. affordable)
PARKING	125		50	210	385 spaces

\*79 units at 30% AMI, 11 units at 50% AMI, 148 units at 60% AMI, 2 units at 120% AMI

Note: Program is based on the previously approved Conditions of Approval, As approved by the Planning Commission February 6, 2019.

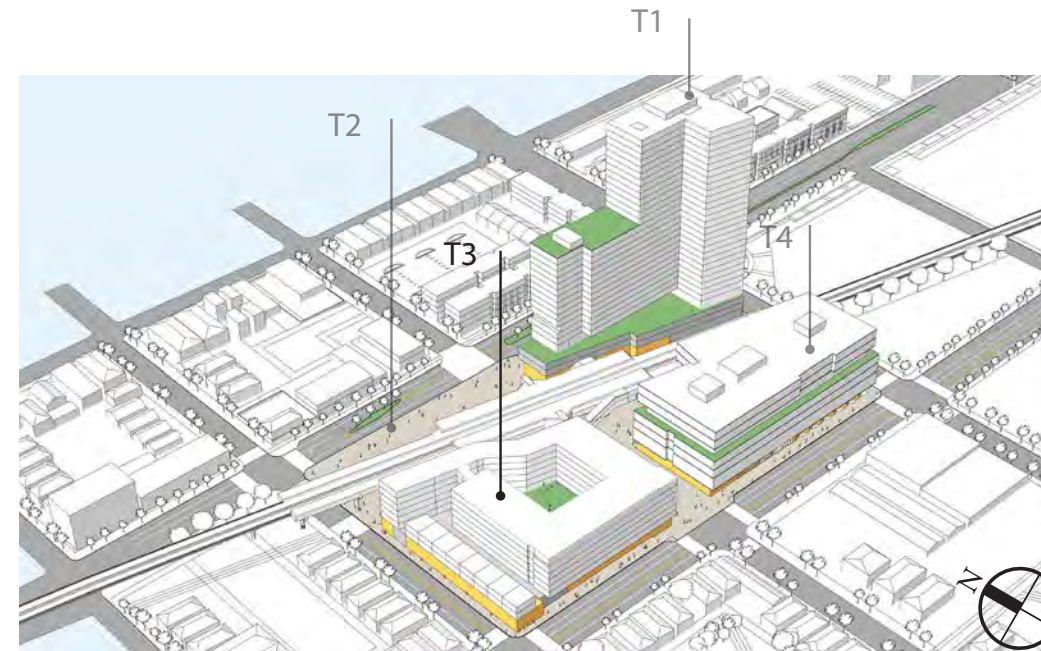

**T3 Open Space Calculation and Parking Analysis**

Residential Open Space Req				
240 Units	200	48,000 SF		
<b>Required Open Space</b>		<b>48,000 SF</b>		
Open Space Provided				
Private Open Space		10,187		
Common Courtyard		14,628 SF		
		<b>24,815*</b> SF		
*Open space waiver of 30,499 sf requested for T3 per Density Bonus Letter.				
T3 Parking Analysis		Pkg		
T3 Req. Pkg	240	0.5	120	
Commercial Pkg	15,944	600	22	
<b>Total</b>		<b>142 Spaces</b>		
PKG Reductions				
Transit	0.3		43 Spaces	
Car Share	0.2		29 Spaces	
<b>Residential PKG Req</b>		<b>71 Spaces</b>		
Parking Provided				
T3 Parking		50* Spaces		
*Parking waiver requested for 21 spaces per Density Bonus Letter.				
Bicycle Parking				
	Multi-family Req	Commerical Req	Total Req	Total Provided
Short Term	12	8	20	20
Long Term	64	2	66	68

**Note:**

The Applicant is requesting a waiver/reduction of the group usable open space requirements for T-3 pursuant to Government Code section 65915 (e); and

The Applicant is requesting a reduction in the amount of parking required for T-3 pursuant to Government Code section 65915 (p)

The ROW encroachment permit application for façade elements will be submitted prior to building permit.

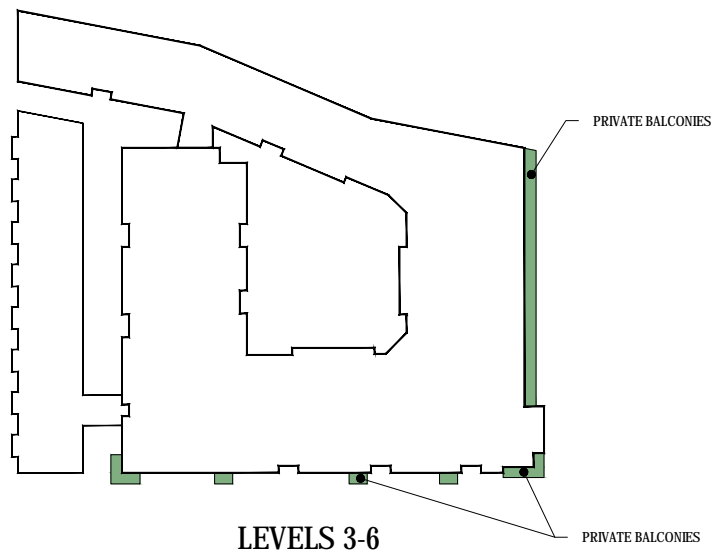
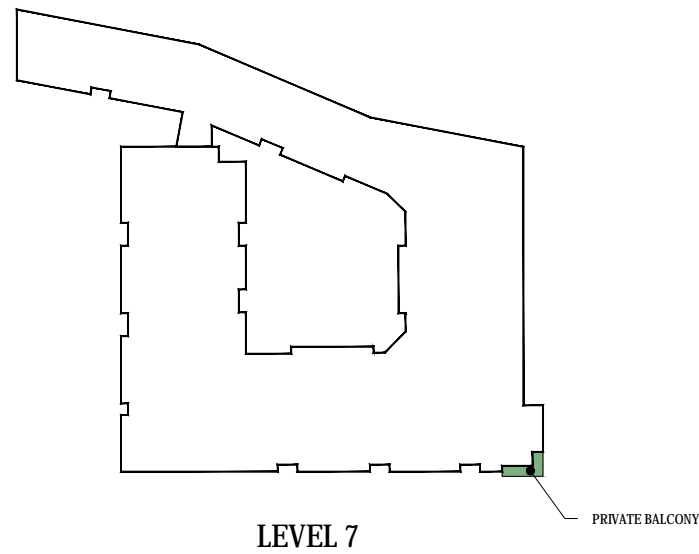
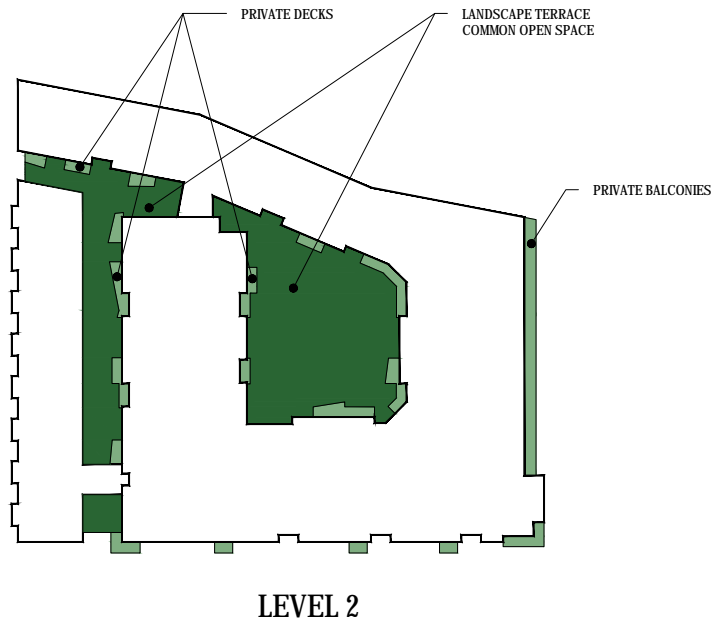

T3 OPEN SPACE SUMMARY		
LEVEL	COMMON	PRIVATE
LV2	10,187 SF	2,528 SF
LV3		1,161 SF
LV4		1,161 SF
LV5		1,161 SF
LV6		1,161 SF
LV7		142 SF
SUBTOTAL	10,187 SF	14,628 SF (X2)
TOTAL T3 OPEN SPACE	24,815 SF*	

\*The Applicant is requesting a waiver/reduction of the group usable open space requirements for T-3 pursuant to Government Code section 65915 (e);

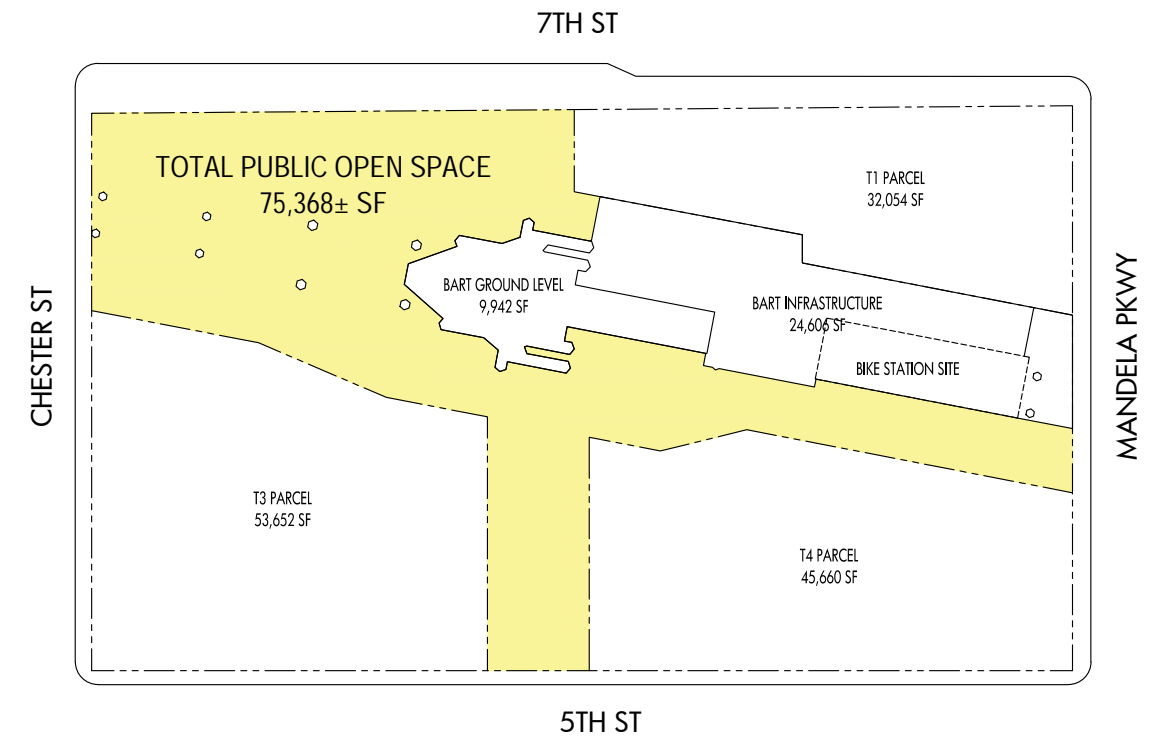

GROUND LEVEL - PUBLIC OPEN SPACE 75,368± SF

GENERAL ZONING INFORMATION	REFERENCE	NOTES
ASSESORS BLOCK	Survey	See Survey; Tract 8046, Blocks 494
ZONING USE DISTRICT	Oak GIS	S-15W
PERMITTED AND/OR CONDITIONAL USES	17.97.010-.020	Residential, Community Assembly, General Retail, Full +Limited Service Retail, Parking, Commercial Office permitted
HEIGHT & BULK DISTRICT	17.97	S-15W 60'; master plan consistent with zoning requirements
GENERAL PLAN / POLICY PLAN	OAK-GIS	General Commercial; West Oakland Specific Plan
HISTORIC OR LANDMARK STATUS	OAK-GIS	None
LIQUEFACTION HAZARD ZONE	OAK-GIS	Severity 4
CONDO CONVERSION IMPACT AREA	OAK-GIS	None
<b>HEIGHT AND BULK CONTROLS</b>		
SITE AREA	Survey	54,096 SF
FLOOR AREA RATIO (FAR)	17.97.130	S-15W 60' - 3.0; Master Plan within zoning density requirements
HEIGHT LIMIT	17.97	60' (Height limit modified to allow 80' tall building pursuant to State Affordable Housing Exemption)
REQUIRED SETBACKS	17.97.060	No Front Yard Setbacks Required; Interior Lot subject to PUD
REAR YARDS / COURTS		None Required
ADJACENCIES		None Significant
UNIT SEPARATION / EXPOSURE REQUIREMENTS	17.108.080	8' minimum at living room window +2' for each floor above = maximum 10% of It width
<b>DETAILED CONTROLS &amp; REQUIREMENTS</b>		
RESIDENTIAL DENSITY LIMITS	17.97.130	S-15W 60' - 375sf/unit; Density increase per State Affordable Housing and PUD density bonus
OPEN SPACE REQUIREMENTS	17.97.130	S-15W 60' - 150sf/unit; Overall master plan within zoning limites
SCREENING & SETBACK OF PARKING & LOADING	17.116.290	All parking garages are screened per zoning requirements
OFF-STREET PARKING - RESIDENTIAL	17.116.060	0.5 parking space per dwelling unit required; Parking meets zoning requirements with approved reductions
OFF-STREET PARKING - RETAIL	17.116.080	1 space/600 Sf of ground floor; Parking meets zoning requirements with approved reductions
OFF-STREET PARKING - COMMERCIAL	17.116.080	None required
OFF-STREET PARKING DIMENSIONS	17.116.200	50-50 compact / standard; or 75% intermediate + 12.5% compact
OFF-STREET DRIVE AISLE DIMENSIONS	17.116.210	21'-24' two way aisle widths
OFF-STREET LOADING - RESIDENTIAL	17.116.120	Loading per zoning requirements
OFF-STREET LOADING - RETAIL	17.116.150	Loading per zoning requirements
LOADING BERTH DIMENSIONS	17.116.220	10'x23', 12' high for residential activities
BICYCLE REQUIREMENTS - RESIDENTIAL	17.117.090	LT: total 60 spaces; ST: total 12 spaces LT: 0.25 spaces per dwelling unit; ST: 0.05 per dwelling unit; bicycle parking provide per zoning code
BICYCLE REQUIREMENTS - RETAIL	17.117.110	LT: total 2 spaces; ST: total 8 spaces LT: 1 per 12k; ST: 1 per 2k; bicycle parking provided per zoning code

# PROJECT SCHEDULE

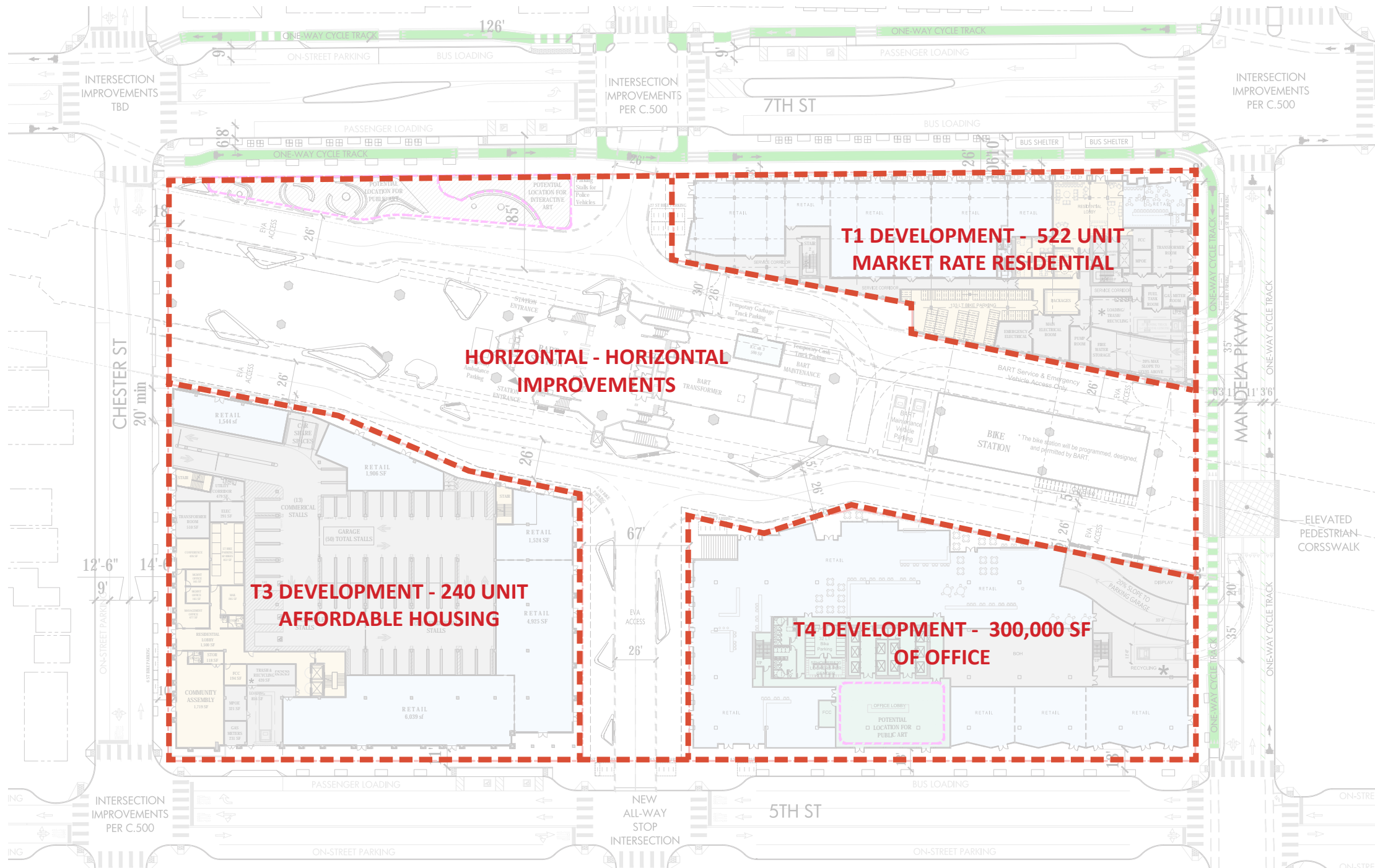

## 1. Horizontal

i.	Submit application for Final Development Plan	1 year following PDP approval	
ii.	Anticipated FDP approval date by Agency	1 year following submittal of Horizontal FDP application	
iii.	Commence construction – Initial PX and/or PZ job (additional PX and PZ jobs will be tied to each later phase)	2 years following FDP approval	

## 2. Phase I – T3 Development (plus PZ/PX for that phase)

i.	Submit application for Final Development Plan	1 year following PDP approval	
ii.	Anticipated FDP approval date by Agency	1 year following submittal of Phase I FDP application	
iii.	Commence construction	2 years following FDP approval (allowing time to secure affordable financing)	

## 3. Phase II – T1 Development & T2 Development (plus PZ/PX for that phase)

i.	Submit application for Final Development Plan	3 years following PDP approval	
ii.	Anticipated FDP approval date by Agency	1 year following submittal of Phase II FDP application	
iii.	Commence construction	The latter of 2 years following FDP approval or 2 years following Phase I commencement of construction	

## 4. Phase III – T4 Development (plus PZ/PX for that phase)

i.	Submit application for Final Development Plan	5 years following PDP approval	
ii.	Anticipated FDP approval date by Agency	1 year following submittal of Phase III FDP application	
iii.	Commence construction	The latter of 2 years following FDP approval or 2 years following Phase II commencement of construction	

All dates are subject to force majeure events

SITE LOCATION



LOCATION OF PROJECT SITE WITHIN WEST OAKLAND NEIGHBORHOOD

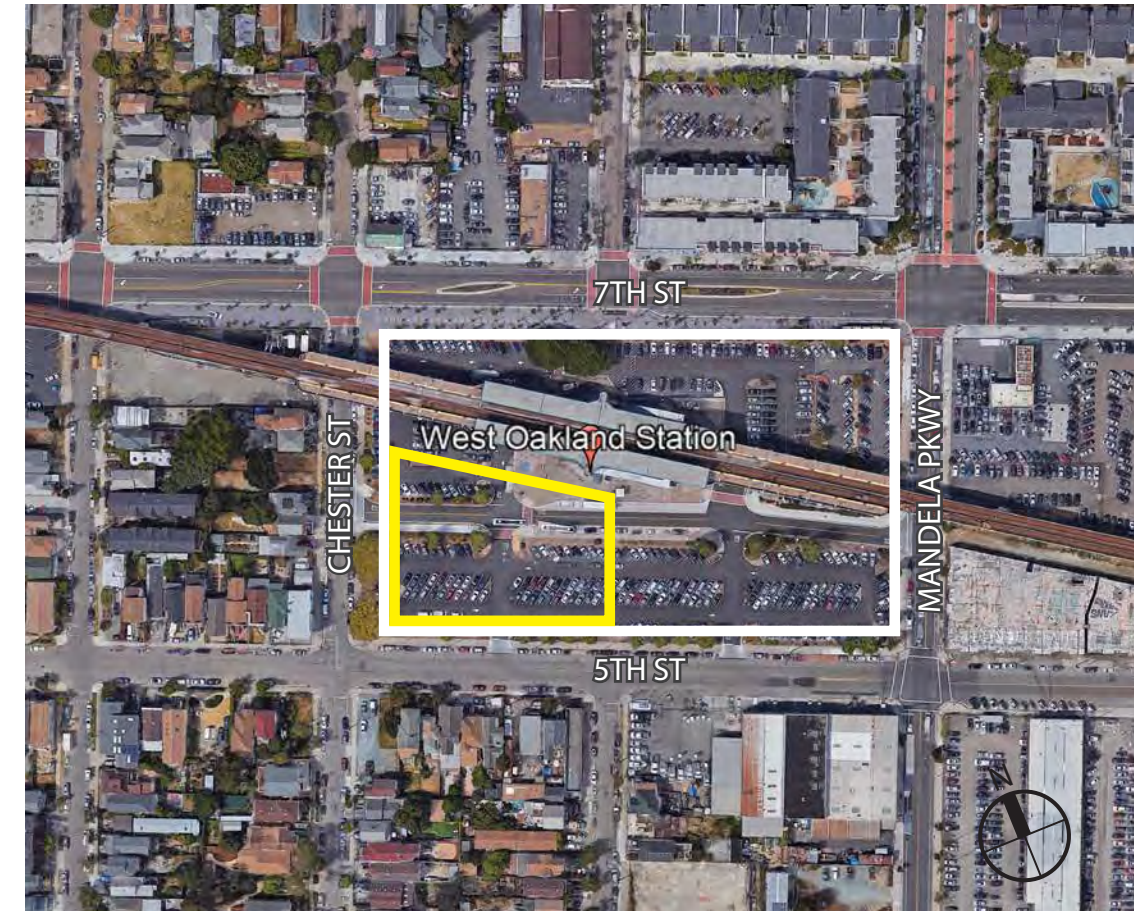

1.40 ACRE PROJECT SITE



NEW HOME RATING SYSTEM, VERSION 7.0

Blueprint Scoresheet

		Points Targeted	Community	Energy	IAQ/Health	Resources	Water	Responsible Party	Blueprint Page No.
		Possible Points							
<b>CALGreen</b>									
Yes	CALGreen Res (REQUIRED)	4		1	1	1	1		
<b>C. LANDSCAPE</b>									
Yes	C1. Plants Grouped by Water Needs (Hydrozoning)	1					1		
<b>C3. Resource Efficient Landscapes</b>									
Yes	C3.1 No Invasive Species Listed by Cal-IPC	1				1			
Yes	C3.3 Drought Tolerant, California Native, Mediterranean Species, or Other Appropriate Species	1					3		
<b>E. EXTERIOR</b>									
Yes	E4. Durable and Non-Combustible Cladding Materials	1				1			
<b>E5. Durable Roofing Materials</b>									
Yes	E5.2 Roofing Warranty for Shingle Roofing	Y	R	R	R	R	R		
<b>F. INSULATION</b>									
<b>F1. Insulation with 30% Post-Consumer or 60% Post-Industrial Recycled Content</b>									
Yes	F1.1 Walls and Floors	1				1			
<b>F2. Insulation that Meets the CDPH Standard Method—Residential for Low Emissions</b>									
Yes	F2.1 Walls and Floors	1			1				
Yes	F2.2 Ceilings	1			1				
<b>G. PLUMBING</b>									
<b>G2. Install Water-Efficient Fixtures</b>									
Yes	G2.1 WaterSense Showerheads 1.8 gpm with Matching Compensation Valve	2					2		
Yes	G2.2 WaterSense Bathroom Faucets with 1.0gpm or less	1					1		
1.28 gpf	G2.3 WaterSense Toilets with a Maximum Performance (MaP) Threshold of No Less Than 500 Grams 1.28gpf OR 1.1 gpf	1					2		
<b>H. HEATING, VENTILATION, AND AIR CONDITIONING</b>									
<b>H6. Whole House Mechanical Ventilation Practices to Improve Indoor Air Quality</b>									
Yes	H6.1 Meet ASHRAE Standard 62.2-2010 Ventilation Residential Standards	Y	R	R	R	R	R		
<b>J. BUILDING PERFORMANCE AND TESTING</b>									
<b>J5. Building Performance Exceeds Title 24 Part 6</b>									
Option 1: Compliance Over Title 24	J5.1 Home Outperforms Title 24	25		25+					
<b>N. COMMUNITY</b>									
<b>N1. Smart Development</b>									
Yes	N1.1 Infill Site	2	1				1		
<b>N2. Home(s)/Development Located Near Transit</b>									
Yes	N2.2. Within 1/2 mile of a Major Transit Stop	2	2						
<b>N3. Pedestrian and Bicycle Access</b>									
<b>N3.1 Pedestrian Access to Services Within 1/2 Mile of Community Services</b>									
10	Enter the number of Tier 1 services								
10	Enter the number of Tier 2 services								
Yes	N9.2 Community Location	2	1		1				
<b>O. OTHER</b>									
Yes	O1. GreenPoint Rated Checklist in Blueprints	Y	R	R	R	R	R		
Yes	O2. Pre-Construction Kickoff Meeting with Rater and Subcontractors	2		0.5		1	0.5		
Yes	O7. Green Appraisal Addendum	Y	R	R	R	R	R		
<b>P. DESIGN CONSIDERATIONS</b>									
<b>P3. Commissioning</b>									
Yes	P3.1 Design Phase	2		1	1				
Yes	P3.2 Construction Phase	3		2	1				
Yes	P3.3 Post-Construction Phase	3		2	1				
<b>Summary</b>									
Total Available Points in Specific Categories		375.5	46	110.5	70	95	54		
Minimum Points Required in Specific Categories		50	2	25	6	6	6		
<b>Total Points Targeted</b>		<b>58</b>	<b>6</b>	<b>31.5</b>	<b>7</b>	<b>6</b>	<b>7.5</b>		



Final Development Plan  
Mandela Station @ West Oakland BART: T3  
1451 7th St, Oakland, CA 94607  
July 24, 2020

GREENPOINT RATED  
CHECKLIST

A-01.06

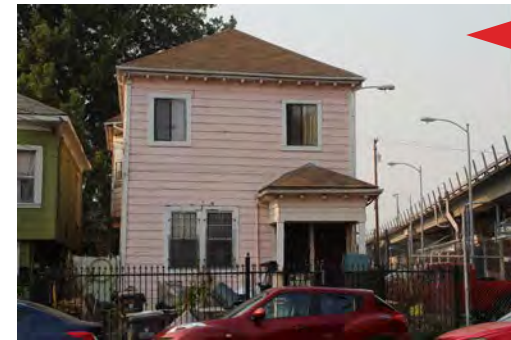

1,2,3,4: VIEW OF WEST RESIDENTIAL HOUSING

5,6: VIEW OF SOUTH RESIDENTIAL HOUSING

7: VIEW OF WEST SIDE OF BART PLAZA

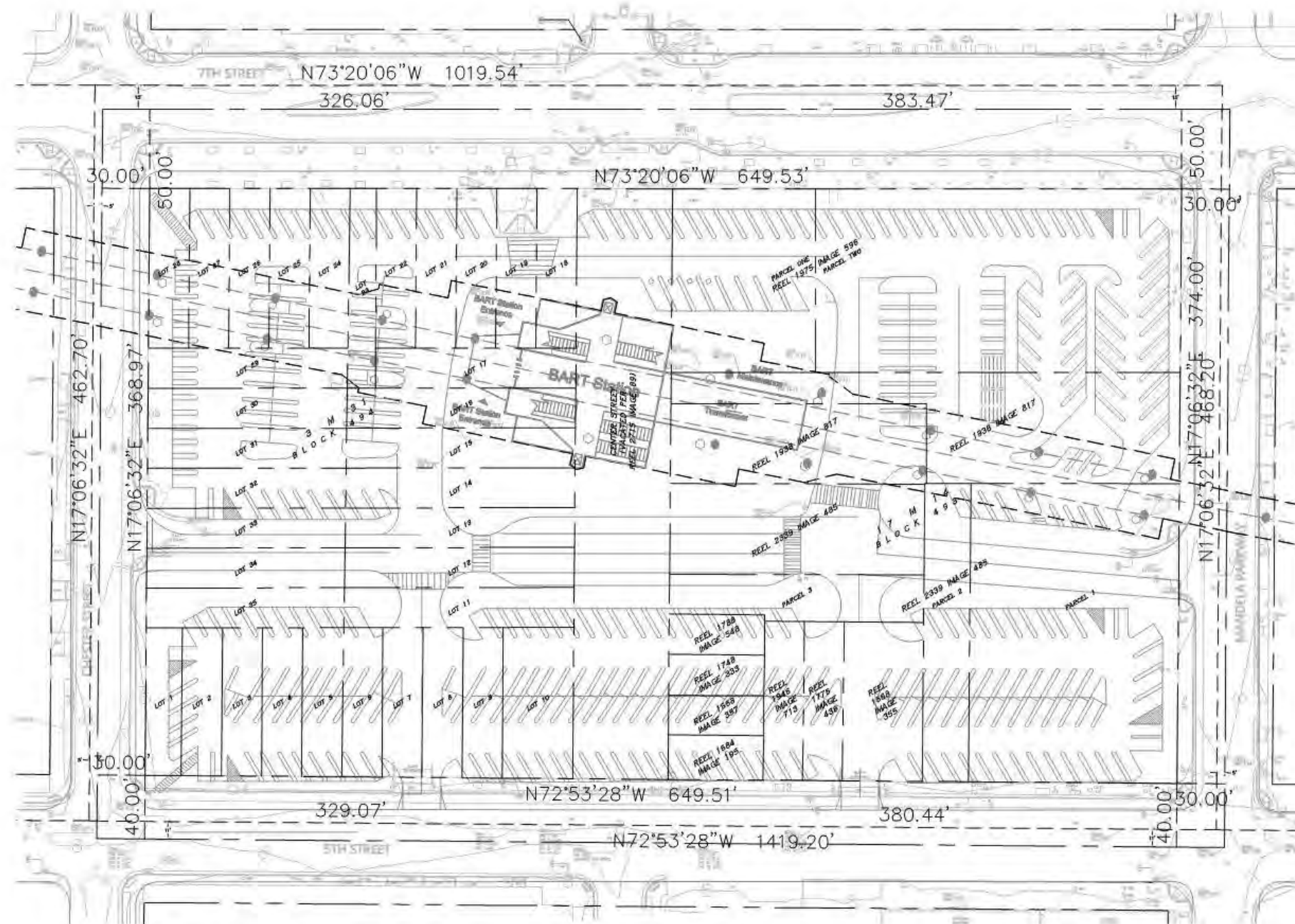

**NOTE:**  
 EXISTING BOUNDARY FROM RECORD INFORMATION FOR  
 PLANNING PURPOSES ONLY

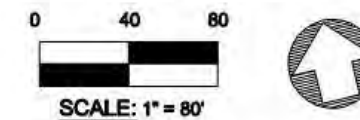



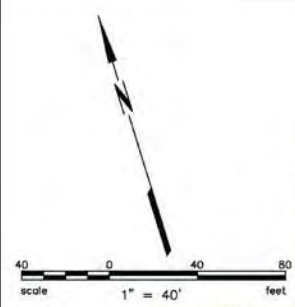

**BASIS OF BEARINGS**

THE BEARING OF NORTH 72°53'28" WEST BETWEEN FOUND MONUMENTS ON 5TH AVENUE BETWEEN HENRY STREET AND KIRKHAM STREET AS SHOWN ON THAT RECORD OF SURVEY, R/S 1687, FILED AUGUST 7, 2000 IN BOOK 25 OF RECORDS OF SURVEY AT PAGES 58-69, INCLUSIVE, ALAMEDA COUNTY RECORDS, WAS TAKEN AS THE BASIS OF BEARINGS FOR THIS SURVEY.

**BENCHMARK**

THE ELEVATIONS SHOWN HEREON ARE BASED ON A FOUND CITY OF OAKLAND BENCHMARK, DESIGNATION 25/H, BEING A BRONZE DISK STAMPED, "SEC 25 STA H," ELEVATION 10.784 FEET (DATUM = MEAN SEA LEVEL).

**NOTES**

1. THE SURVEY WAS CONDUCTED IN NOVEMBER OF 2018.
2. ALL UNITS ARE IN US SURVEY FEET AND DECIMALS THEREOF.
3. THE TOPOGRAPHIC MAPPING SHOWN HEREON IS A WORKING DOCUMENT. THE TOPOGRAPHIC SURVEY AND MAPPING IS IN PROGRESS AND HAS NOT BEEN COMPLETED OR FINALIZED.

**SURVEYOR'S STATEMENT:**

THIS MAP CORRECTLY REPRESENTS A SURVEY MADE BY ME OR UNDER MY DIRECTION IN CONFORMANCE WITH THE REQUIREMENTS OF THE PROFESSIONAL LAND SURVEYOR'S ACT.

KEVIN STEIN, P.L.S. NO. 9028

DATE: \_\_\_\_\_

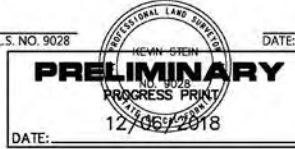

Revisions	
No.	Description

Date:	12/06/2018
Scale:	AS SHOWN
Design:	N/A
Drawn:	ADD
Approved:	KS
Job No.:	180384

Drawing Number:  
**180384**  
1 of 5

- ### SYMBOLS & LEGEND
- EXISTING**
- FOUND CITY OF OAKLAND MONUMENT
  - VALVE
  - FIRE HYDRANT
  - BACKFLOW PREVENTION DEVICE
  - RISER
  - SIGN
  - STREET LIGHT (UNLESS NOTED OTHERWISE)
  - LIGHT POLE (UNLESS NOTED OTHERWISE)
  - GUY ANCHOR
  - UTILITY POLE
  - TELEPHONE MANHOLE
  - MANHOLE
- - - SUBJECT PROPERTY
  - - - ADJOINING LOT
  - - - CENTERLINE
  - - - SURVEY TIE
  - - - STORM DRAIN
  - - - SANITARY SEWER
  - - - OVERHEAD UTILITY LINE
  - - - CONCRETE
  - ◻ DETECTABLE WARNING

- ### ABBREVIATIONS
- AC ASPHALT CONCRETE
  - CA CABLE
  - CB CATCH BASIN
  - CO CLEAN OUT
  - COMM COMMUNICATION
  - CONC CONCRETE
  - DI DROP INLET
  - DWY DRIVEWAY
  - E ELECTRIC
  - EP EDGE OF PAVEMENT
  - FL SURFACE FLOWLINE
  - G GAS
  - GYP GUY POLE
  - INV BOTTOM INSIDE OF PIPE
  - LG LIP OF GUTTER
  - M METER
  - MH MANHOLE
  - OH OVERHEAD UTILITY LINE
  - SD STORM DRAIN
  - SL STREETLIGHT
  - SS SANITARY SEWER
  - TC TOP FACE OF CURB
  - TEL TELECOMMUNICATION LINE
  - TG TOP OF GRATE
  - TS TRAFFIC SIGNAL
  - TV TELEVISION
  - UB UTILITY BOX
  - V VALVE
  - VLT VAULT
  - W WATER
  - WM WATER METER

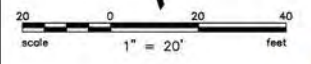

1646 N. CALIFORNIA BLVD.,  
 SUITE 400  
 WALNUT CREEK, CA 94596  
 (925) 940-2200  
 www.bkf.com

**BKF 100 YEARS**  
 ENGINEERS · SURVEYORS · PLANNERS

TOPOGRAPHIC AND BOUNDARY SURVEY  
 WEST OAKLAND BART

OAKLAND      COUNTY OF ALAMEDA      CALIFORNIA

Date:	12/06/2018	No.:
Scale:	AS SHOWN	
Design:	N/A	
Drawn:	ADD	
Approved:	KS	
Job No.:	180384	

Revisions

Drawing Number: **180384**

DRAWING NAME: K:\2018\180384\180384\_01\180384\_01.dwg; DATE: 12/06/18 10:30:45 AM; USER: JAMES.BARTON; PLOT DATE: 12/06/18 10:30:45 AM; PLOT USER: JAMES.BARTON



**SYMBOLS & LEGEND**

**EXISTING**

- FOUND CITY OF OAKLAND MONUMENT
- VALVE
- FIRE HYDRANT
- BACKFLOW PREVENTION DEVICE
- RISER
- SIGN
- STREET LIGHT (UNLESS NOTED OTHERWISE)
- LIGHT POLE (UNLESS NOTED OTHERWISE)
- GUY ANCHOR
- UTILITY POLE
- TELEPHONE MANHOLE
- MANHOLE

**ABBREVIATIONS**

- AC ASPHALT CONCRETE
- CA CABLE
- CB CATCH BASIN
- CO CLEAN OUT
- COMM COMMUNICATION
- CONC CONCRETE
- DI DROP INLET
- DWY DRIVEWAY
- E ELECTRIC
- EP EDGE OF PAVEMENT
- FL SURFACE FLOWLINE
- G GAS
- GYP GUY POLE
- INV BOTTOM INSIDE OF PIPE
- LG LIP OF GUTTER
- M METER
- MH MANHOLE
- OH OVERHEAD UTILITY LINE
- SD STORM DRAIN
- SL STREETLIGHT
- SS SANITARY SEWER
- TC TOP FACE OF CURB
- TEL TELECOMMUNICATION LINE
- TG TOP OF GRATE
- TS TRAFFIC SIGNAL
- TV TELEVISION
- UB UTILITY BOX
- V VALVE
- VLT VAULT
- W WATER
- WM WATER METER

1646 N. CALIFORNIA BLVD.,  
SUITE 400  
WALNUT CREEK, CA 94596  
(925) 940-2200  
www.bkf.com

**BKF 100 YEARS**  
ENGINEERS · SURVEYORS · PLANNERS

CALIFORNIA  
COUNTY OF ALAMEDA

TOPOGRAPHIC AND BOUNDARY SURVEY  
WEST OAKLAND BART

Date:	12/06/2018	No.:	
Scale:	AS SHOWN	Revisions:	
Design:	N/A		
Drawn:	ADD		
Approved:	KS		
Job No.:	180384		
Drawing Number:	180384		

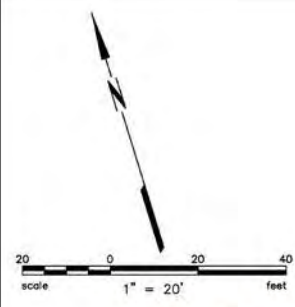

DRAWING NAME: K:\2018\180384\West Oakland BART.dwg; User: JAS; Date: 12/06/2018 10:00:00 AM; Plot Date: 12/06/2018 10:00:00 AM; Plot Scale: 1/1; Plot Units: Feet; Plot Orientation: Landscape; Plot Color: Black; Plot Lineweight: 0.20; Plot Style: Standard; Plot Weight: 0.20; Plot Color: Black; Plot Lineweight: 0.20; Plot Style: Standard; Plot Weight: 0.20

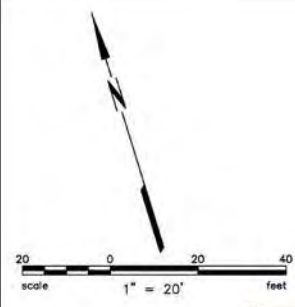

**SYMBOLS & LEGEND**

	EXISTING	FOUND CITY OF OAKLAND MONUMENT
	VALVE	VALVE
	FIRE HYDRANT	FIRE HYDRANT
	BACKFLOW PREVENTION DEVICE	BACKFLOW PREVENTION DEVICE
	RISER	RISER
	SIGN	SIGN
	STREET LIGHT (UNLESS NOTED OTHERWISE)	STREET LIGHT (UNLESS NOTED OTHERWISE)
	LIGHT POLE (UNLESS NOTED OTHERWISE)	LIGHT POLE (UNLESS NOTED OTHERWISE)
	UTILITY POLE	UTILITY POLE
	GUY ANCHOR	GUY ANCHOR
	TELEPHONE MANHOLE	TELEPHONE MANHOLE
	MANHOLE	MANHOLE
	SUBJECT PROPERTY	SUBJECT PROPERTY
	ADJOINING LOT	ADJOINING LOT
	CENTERLINE	CENTERLINE
	SURVEY TIE	SURVEY TIE
	STORM DRAIN	STORM DRAIN
	SANITARY SEWER	SANITARY SEWER
	OVERHEAD UTILITY LINE	OVERHEAD UTILITY LINE
	CONCRETE	CONCRETE
	DETECTABLE WARNING	DETECTABLE WARNING

**ABBREVIATIONS**

AC	ASPHALT CONCRETE
CA	CABLE
CB	CATCH BASIN
CO	CLEAN OUT
COMM	COMMUNICATION
CONC	CONCRETE
DI	DROP INLET
DWY	DRIVEWAY
E	ELECTRIC
EP	EDGE OF PAVEMENT
FL	SURFACE FLOWLINE
G	GAS
GYP	GUY POLE
INV	BOTTOM INSIDE OF PIPE
LG	LIP OF GUTTER
M	METER
MH	MANHOLE
OH	OVERHEAD UTILITY LINE
SD	STORM DRAIN
SL	STREETLIGHT
SS	SANITARY SEWER
TC	TOP FACE OF CURB
TEL	TELECOMMUNICATION LINE
TG	TOP OF GRATE
TS	TRAFFIC SIGNAL
TV	TELEVISION
UB	UTILITY BOX
V	VALVE
VL	VAULT
W	WATER
WM	WATER METER



1646 N. CALIFORNIA BLVD.,  
SUITE 400  
WALNUT CREEK, CA 94596  
(925) 940-2200  
www.bkf.com

**BKF 100 YEARS**  
ENGINEERS, SURVEYORS, PLANNERS

CALIFORNIA  
COUNTY OF ALAMEDA

TOPOGRAPHIC AND BOUNDARY SURVEY  
WEST OAKLAND BART

Date:	12/06/2018
Scale:	AS SHOWN
Design:	N/A
Drawn:	ADD
Approved:	KS
Job No.:	180384

Revisions

No.	
-----	--

Drawing Number:  
**180384**

5 of 5

DRAWING NAME: K:\Projects\180384\180384\_001\180384\_001.dwg; DATE: 12/06/2018 10:00:00 AM; USER: BKF\BKF\BKF; PLOT DATE: 12/06/2018 10:00:00 AM; PLOT USER: BKF\BKF\BKF; PLOT DEVICE: HP DesignJet 500; PLOT SCALE: 1"=20'; PLOT SHEET: 1 OF 1

# VESTING TENTATIVE PARCEL MAP NO. 10940

FOR CONDOMINIUM PURPOSES

**SHEET INDEX**

SHEET #	SHEET TITLE
1	TITLE SHEET/EXISTING SITE PLAN
2	PROPOSED SITE PLAN
3	EMERGENCY VEHICLE ACCESS EASEMENT

**SYMBOLS & LEGEND**

**EXISTING**

[Symbol]	VALVE
[Symbol]	FIRE HYDRANT
[Symbol]	BACKFLOW PREVENTION DEVICE
[Symbol]	RISER
[Symbol]	SIGN
[Symbol]	STREET LIGHT
[Symbol]	LIGHT POLE
[Symbol]	GUY ANCHOR
[Symbol]	UTILITY POLE
[Symbol]	TELEPHONE MANHOLE
[Symbol]	MANHOLE
[Symbol]	EXISTING PROPERTY LINE
[Symbol]	ADJOINING LOT CENTERLINE
[Symbol]	SURVEY TRIE
[Symbol]	STORM DRAIN
[Symbol]	SANITARY SEWER
[Symbol]	OVERHEAD UTILITY LINE
[Symbol]	CONCRETE
[Symbol]	DETECTABLE WARNING BOUNDARY LINE

**ABBREVIATIONS**

AC	ASPHALT CONCRETE
CA	CABLE
CB	CATCH BASIN
CO	CLEAN OUT
COMM	COMMUNICATION
CONC	CONCRETE
DBH	DIAMETER AT BREAST HEIGHT
DI	DROP INLET
DWY	DRIVEWAY
E	ELECTRIC
EP	EDGE OF PAVEMENT
EVAE	EMERGENCY VEHICLE ACCESS EASEMENT
FL	SURFACE FLOWLINE
G	GAS
GYP	GUY POLE
INV	BOTTOM INSIDE OF PIPE
LG	LIP OF GUTTER
M	METER
MH	MANHOLE
MIN	MINIMUM
OH	OVERHEAD UTILITY LINE
PL	PROPERTY LINE
R	RADIUS
SD	STORM DRAIN
SF	SQUARE FEET
SL	STREETLIGHT
SS	SANITARY SEWER
(T)	TOTAL
TC	TOP FACE OF CURB
TEL	TELECOMMUNICATION LINE
TG	TOP OF GRATE
TS	TRAFFIC SIGNAL
TV	TELEVISION
UB	UTILITY BOX
V	VALVE
VA	VAULT
W	WATER
WM	WATER METER

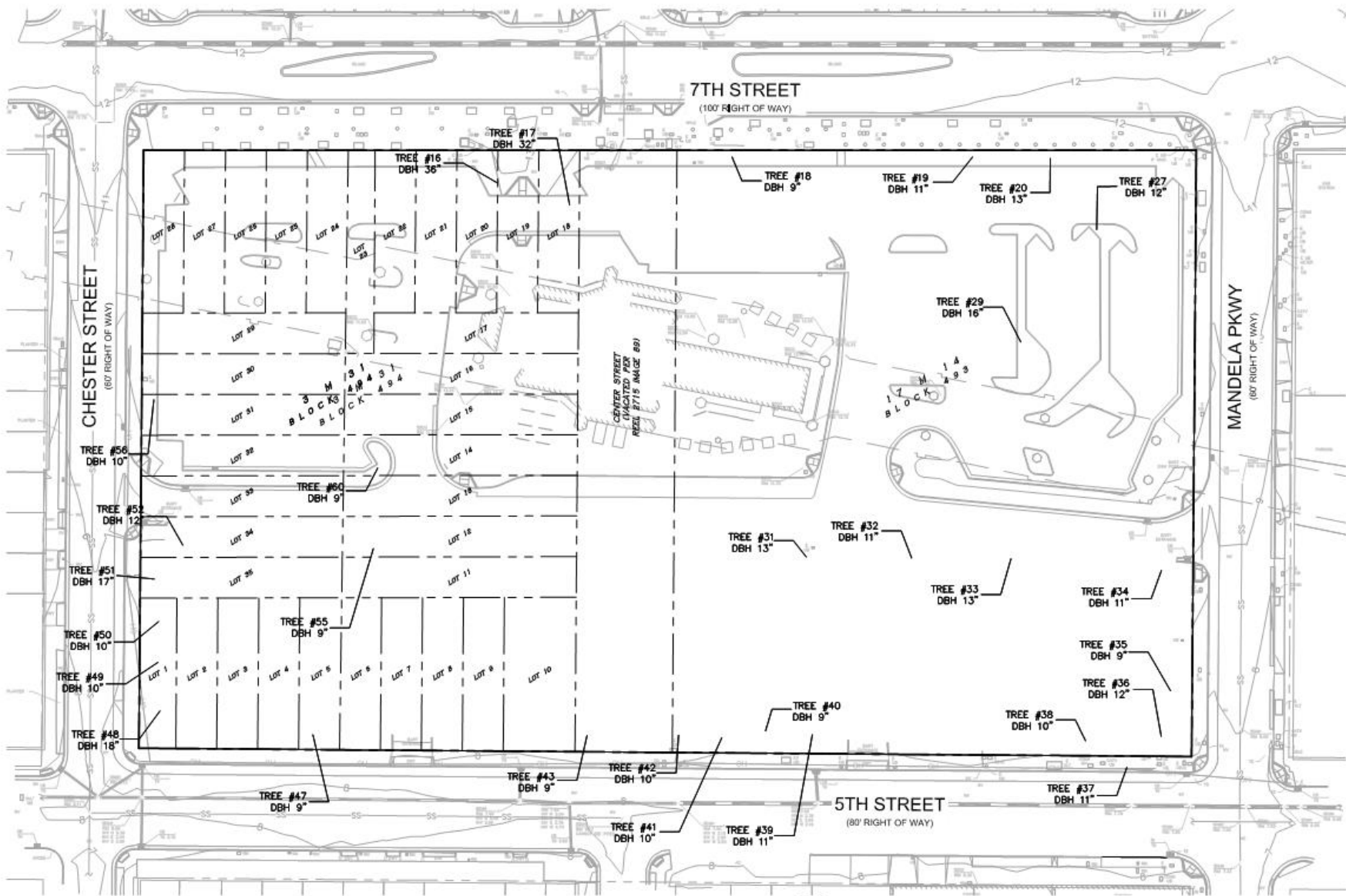

**PROPERTY ADDRESS:**  
1451 7TH STREET  
OAKLAND, CA 94607

**OWNER AND SUBDIVIDER:**  
SAN FRANCISCO BAY AREA RAPID TRANSIT DISTRICT  
300 LAKESIDE DRIVE, 22ND FLOOR  
OAKLAND, CA 94612  
PHONE: 510-597-6300

**BASIS OF BEARINGS**

THE BEARING OF NORTH 72°53'28" WEST BETWEEN FOUND MONUMENTS ON 5TH STREET BETWEEN HENRY STREET AND KIRKHAM STREET AS SHOWN ON THAT RECORD OF SURVEY, R/S 1687, FILED AUGUST 7, 2000 IN BOOK 25 OF RECORDS OF SURVEY AT PAGES 58-59, INCLUSIVE, ALAMEDA COUNTY RECORDS, WAS TAKEN AS THE BASIS OF BEARINGS FOR THIS SURVEY.

**BENCHMARK**

THE ELEVATIONS SHOWN HEREON ARE BASED ON A FOUND CITY OF OAKLAND BENCHMARK, DESIGNATION 25/H, BEING A BRONZE DISK STAMPED, "SEC 25 STA H," ELEVATION 10.784 FEET (DATUM = MEAN SEA LEVEL).

**NOTES**

1. BASED ON INFORMATION CONTAINED IN THE PRELIMINARY TITLE REPORT, ORDER NUMBER NCS-891852-SC, DATED JANUARY 31, 2018, PROVIDED BY FIRST AMERICAN TITLE COMPANY, THE SUBJECT PROPERTY IS OWNED BY SFBART BEING ASSESSOR PARCEL NUMBERS 004-0077-003, 004-0071-003, AND THE VACATION OF CENTER STREET; THERE ARE 36 PARCELS, NOT INCLUDING THE VACATION OF CENTER STREET, THE EXISTING PARCELS WILL BE RECONFIGURED TO CREATE 3 LOTS AND ONE REMAINDER PARCEL VIA PARCEL MAP TO BE PROCESSED.
2. THE INTENT OF THE MAP IS TO MERGE THE 36 PARCELS AND THE VACATED CENTER STREET INTO THE FOUR CONSOLIDATE PARCELS DEFINING THE KEY COMPONENTS OF THE NEW DEVELOPMENT: LOT 1 MARKET RATE RESIDENTIAL TOWER, LOT 2 OFFICE BUILDING, LOT 3 AFFORDABLE HOUSING, AND THE DESIGNATED REMAINDER PARCEL FOR THE EXISTING WEST OAKLAND BART STATION AND NEW ENTRY PLAZAS.
3. THE CONTROL SURVEY WAS CONDUCTED IN NOVEMBER OF 2018.
4. ALL UNITS ARE IN US SURVEY FEET AND DECIMALS THEREOF.
5. THE TOPOGRAPHIC SURVEY IS BASED ON A FIELD SURVEY COMPLETED IN DECEMBER 2018.
6. ALL BUILDINGS TO THE NORTH OF THE BART STATION SHALL BE 30' FROM THE BART PLATFORM, AND ALL BUILDINGS TO THE SOUTH OF THE BART STATION SHALL BE 33' FROM THE BART PLATFORM.
7. ALL EMERGENCY VEHICLE ACCESS EASEMENTS SHALL BE 26' WIDE.
8. LOTS 1, 2 AND 3 ARE ALLOWED UP TO FOUR COMMERCIAL CONDOMINIUMS ON EACH LOT.
9. MULTIPLE MAPS MAY BE FILED FOR THIS PROJECT.

**SURVEYOR'S STATEMENT:**

THIS MAP CORRECTLY REPRESENTS A SURVEY MADE BY ME OR UNDER MY DIRECTION IN CONFORMANCE WITH THE REQUIREMENTS OF THE PROFESSIONAL LAND SURVEYOR'S ACT.

PAUL KITTEDGE  
PROJECT MANAGER  
P.L.S. # 5790



DATE: \_\_\_\_\_

Tree number	DBH (in)	Species Name
16	36	Pinus Pinea
17	32	Pinus Pinea
20	13	Liriodendron Tulipifera
29	12	Maytenus Boaria
29	16	Maytenus Boaria
31	13	Liriodendron Tulipifera
33	13	Liriodendron Tulipifera
36	12	Liriodendron Tulipifera
48	18	Platanus X Acerifolia
51	17	Platanus X Acerifolia
52	12	Liriodendron Tulipifera

EXISTING CONDITIONS  
SCALE 1"=40'



KEY MAP  
SCALE 1"=500'



DRAWING NAME: K:\2018\190384\_WestOakland\_BART\_T00\_Survey\ENG\TENTATIVE PARCEL MAP\190384\T00\_Survey\190384.dwg  
PLOT DATE: 04-06-20 PLOTTED BY: mitr

No.	Description	Date

Revisions	
No.	Description
04/06/2020	AS SHOWN
	IN CC
	REVISED ES
	No:20180384

**TENTATIVE  
PARCEL MAP  
C-1.01B**

DRAWING NAME: K:\2018\190384\_WestOakland\_BART\_TOD\_Survey\ENG\TENTATIVE PARCEL MAP\SHEETS\02\02\01\01.dwg  
PLOT DATE: 04-06-20 PLOTTED BY: mtr

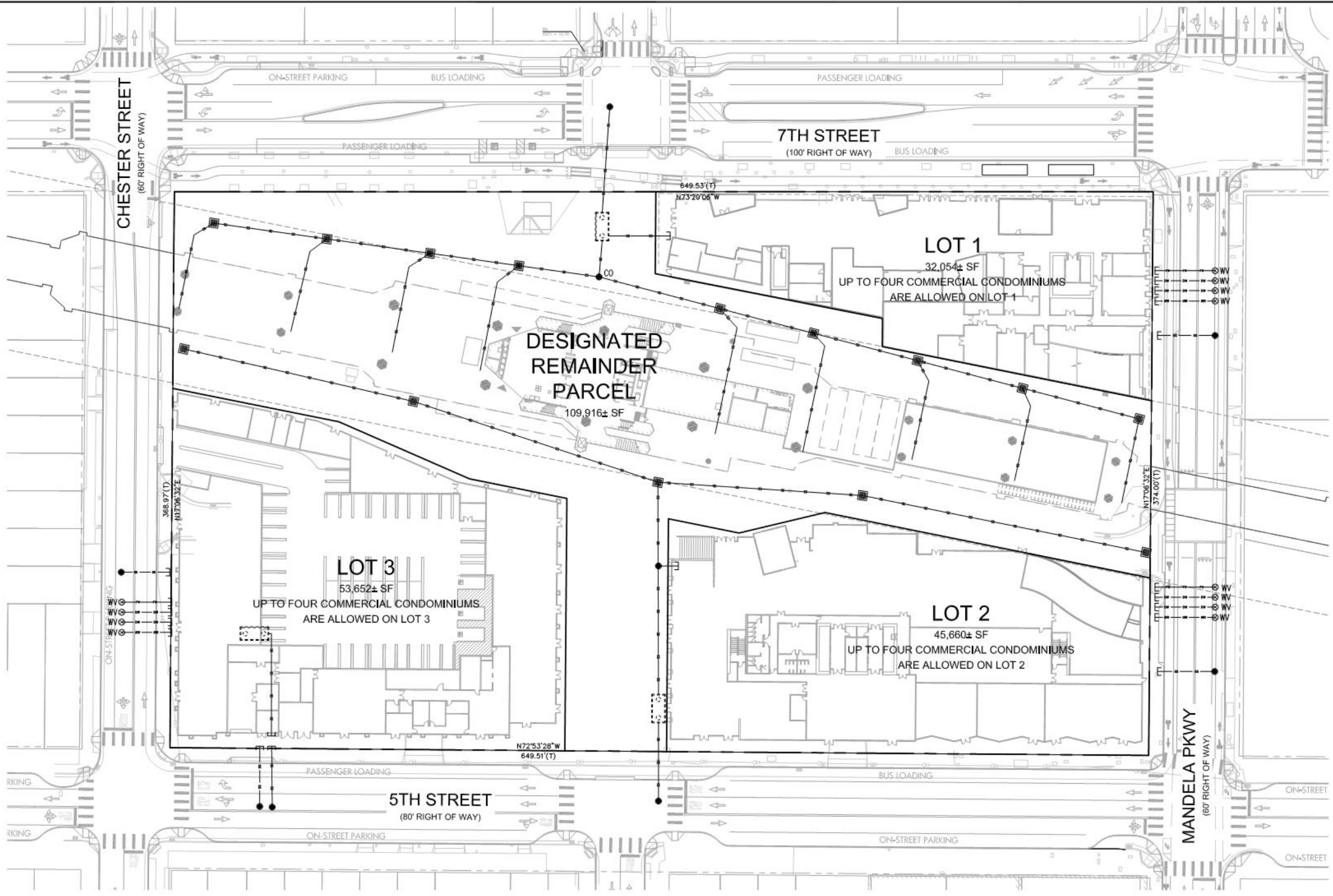

**LEGEND**

BOUNDARY LINE  
PROPOSED PARCEL LINE

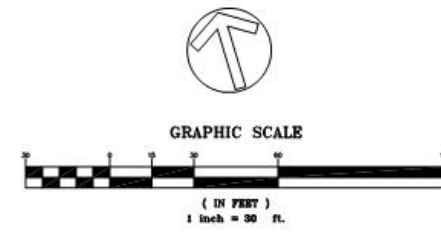
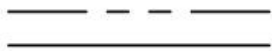

Revisions	No.	Date
AS SHOWN		04/06/2020
CC		
ES		
ES		
No. 20180384		

TENTATIVE  
PARCEL MAP  
C-1.01C

DRAWING NAME: K:\2018\190384\_WestOak\ond\_BART\_TOD\_Survey\ENG\_TENTATIVE PARCEL MAP\SHEETS\05W0BTMEA.dwg  
PLOT DATE: 04-06-20 PLOTTED BY: mitr

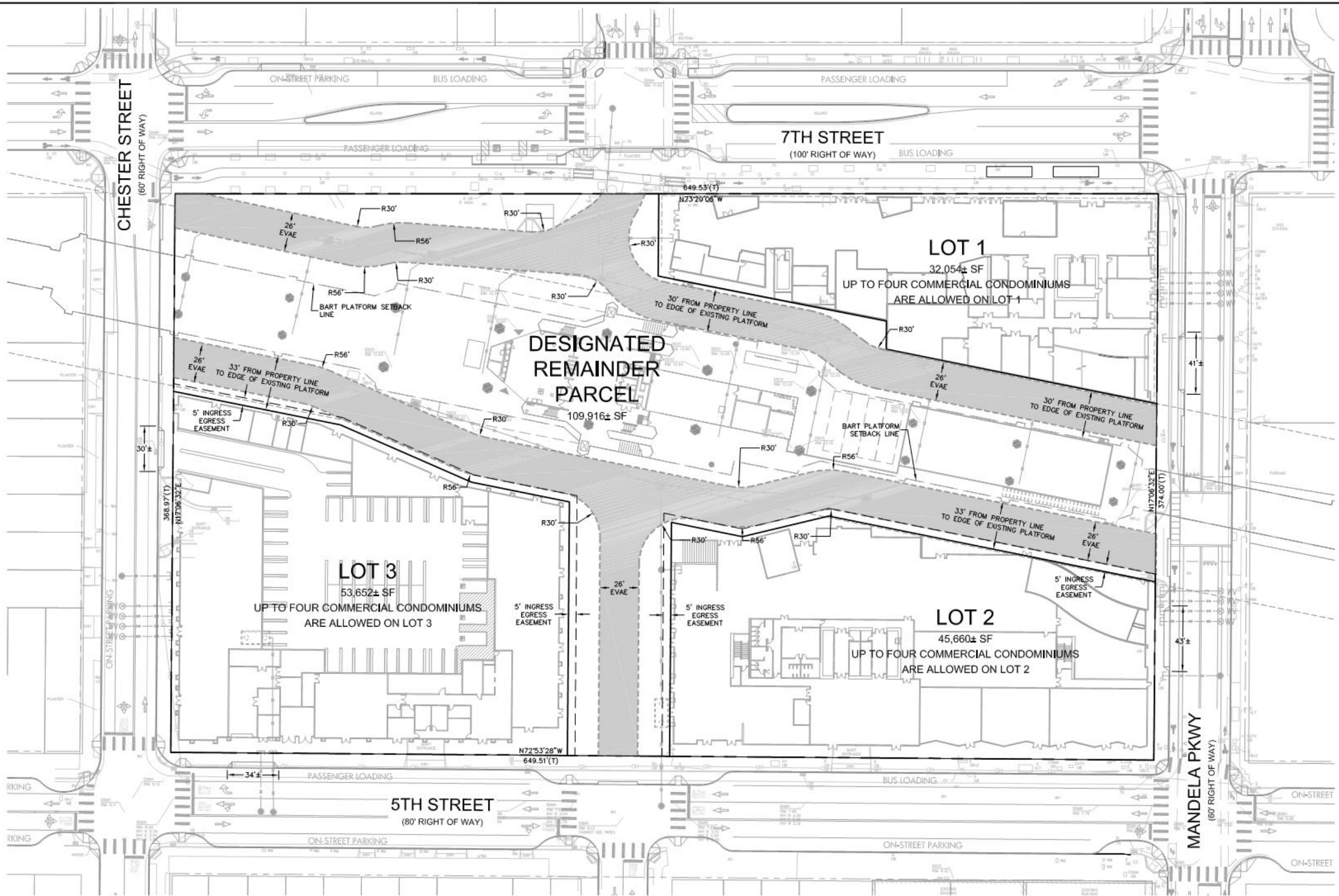

- LEGEND**
- PROPOSED EVAE
  - BOUNDARY LINE
  - PROPOSED PARCEL LINE

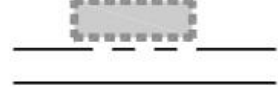

EMERGENCY VEHICLE ACCESS EASEMENT

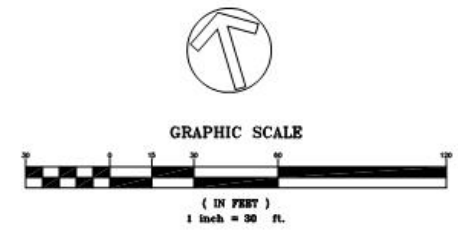



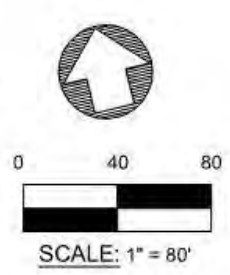
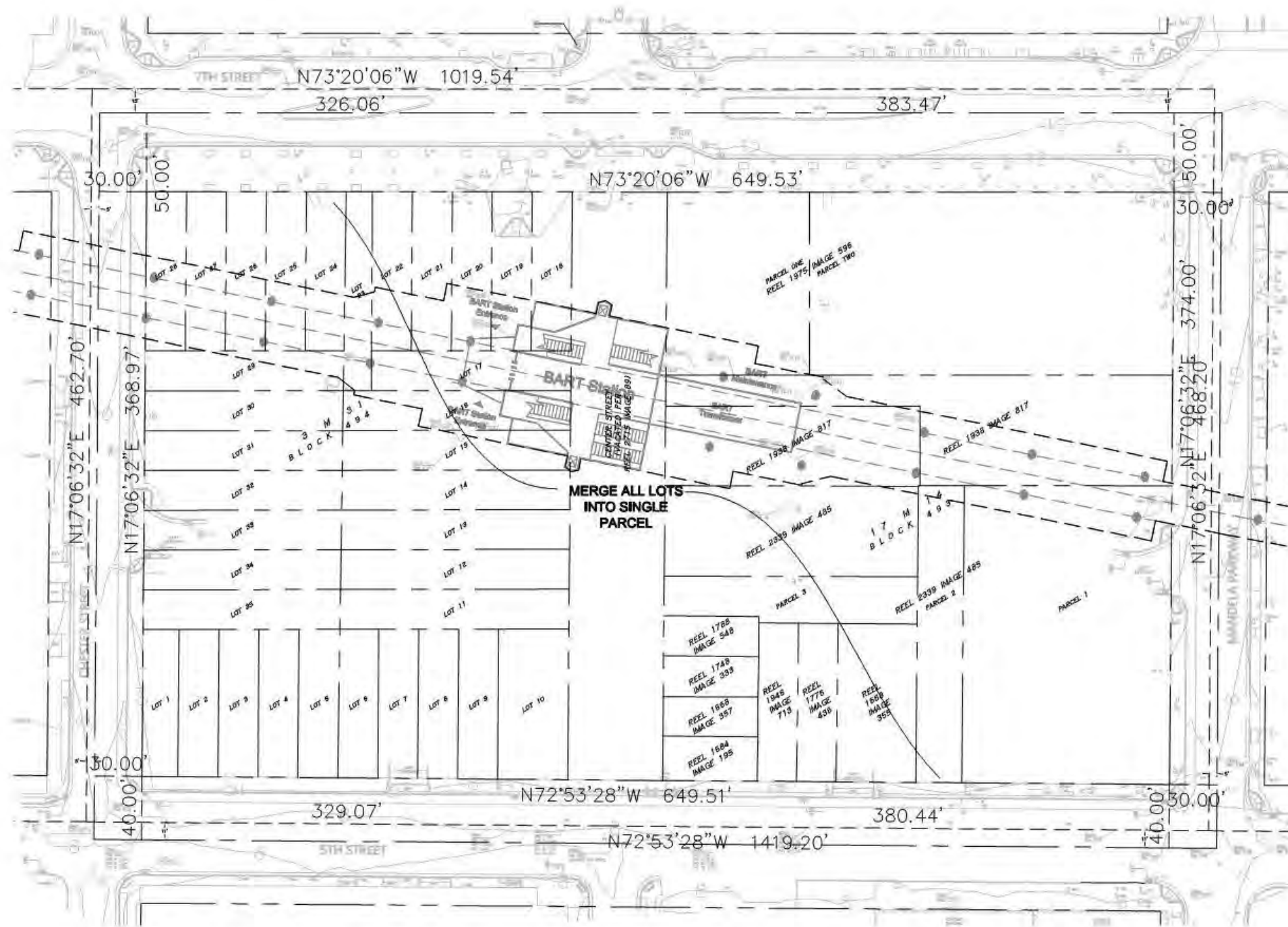

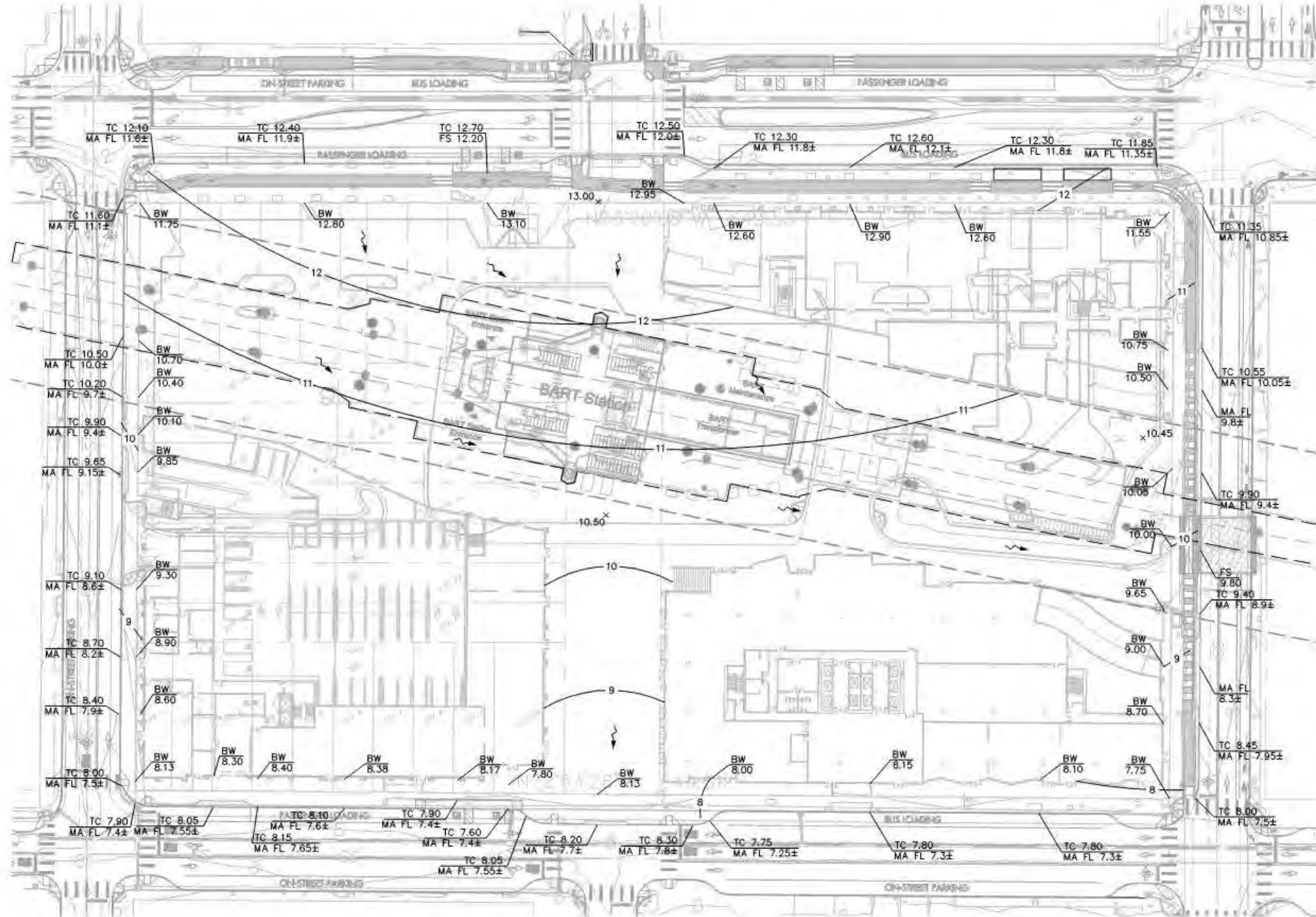

**ABBREVIATIONS:**

FF	FINISHED FLOOR
FG	FINISHED GROUND
FS	FINISHED SURFACE
FL	FLOW LINE
MA	MATCH
TC	TOP OF CURB
TS	TOP OF STEP
TW	TOP OF WALL

**LEGEND:**

	DIRECTION OF PROPOSED DRAINAGE
	GRADE BREAK
	CONTOUR

**GRADING NOTES:**

1. TC ELEVATIONS ARE 6" ABOVE ADJACENT PAVEMENT FL ELEVATIONS, UNLESS OTHERWISE NOTED ON PLAN.



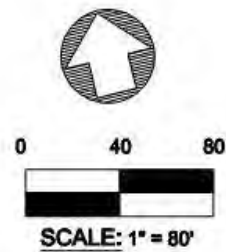

**EARTHWORK SUMMARY:**

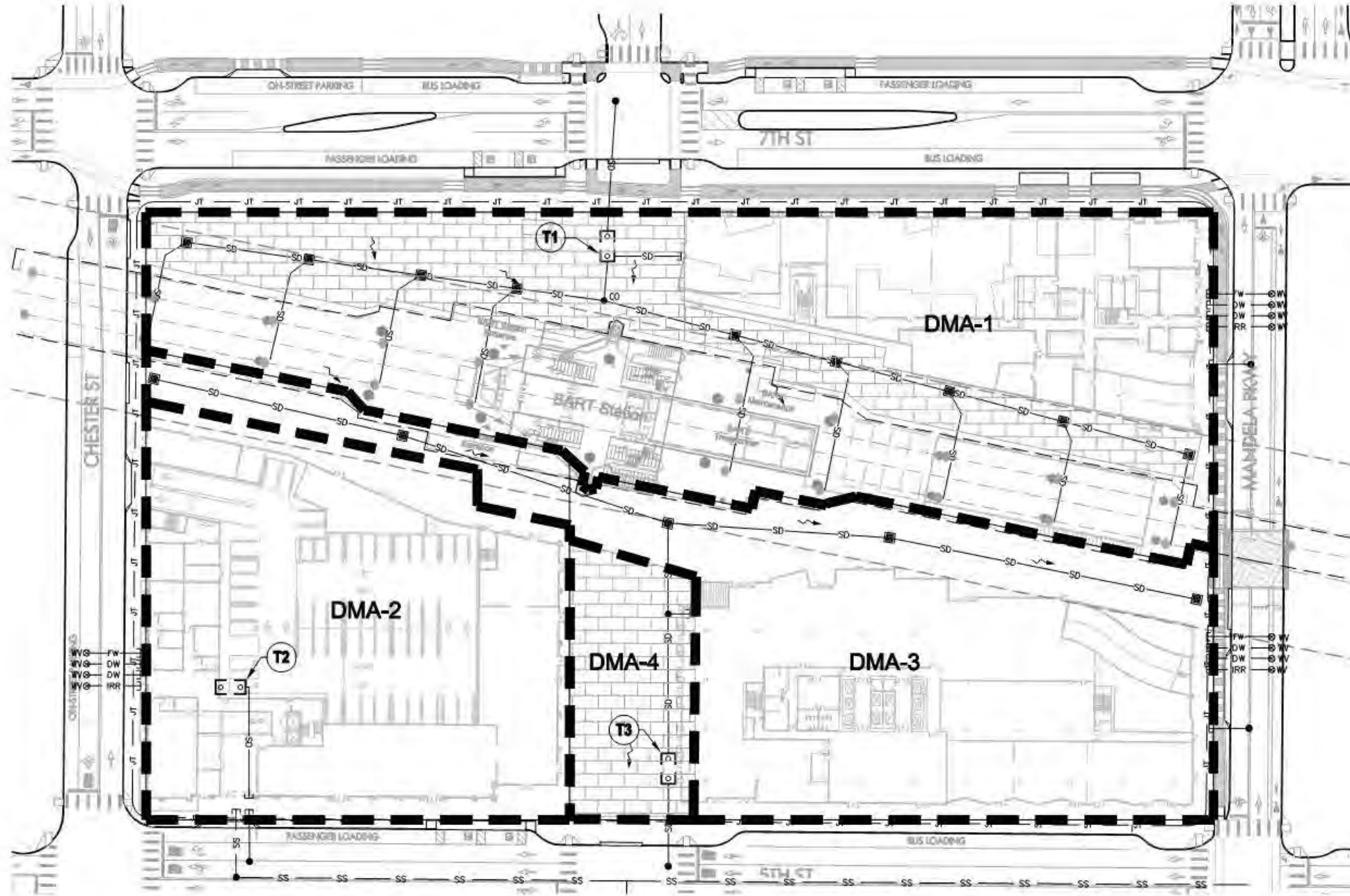
TOTAL EXCAVATION: 51,303 CUBIC YARDS  
 TOTAL FILL: 0 CUBIC YARDS  
 TOTAL OFFHAUL: 51,303 CUBIC YARDS





**LEGEND:**

-  DRAINAGE MANAGEMENT AREA (DMA)
-  PERMEABLE PAVING
-  FILTER VAULT  
SEE SHEET C3.01
-  TREATMENT AREA LABEL

**STORMWATER MANAGEMENT NOTES:**

1. THE TREATMENT VAULTS WERE SELECTED BASED ON 243,131 SF OF IMPERVIOUS SURFACE AND A TREATMENT INTENSITY OF 0.2 IN/HR. SEE OLD CASTLE WASHINGTON GULD PF-V-8-WA-0001 PERK FILTER DETAIL ON SHEET C3.01. ALL FILTER VAULTS SHOWN ARE COMPRISED OF (31) - 18" CARTRIDGES.

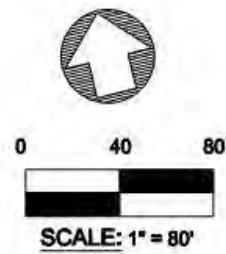

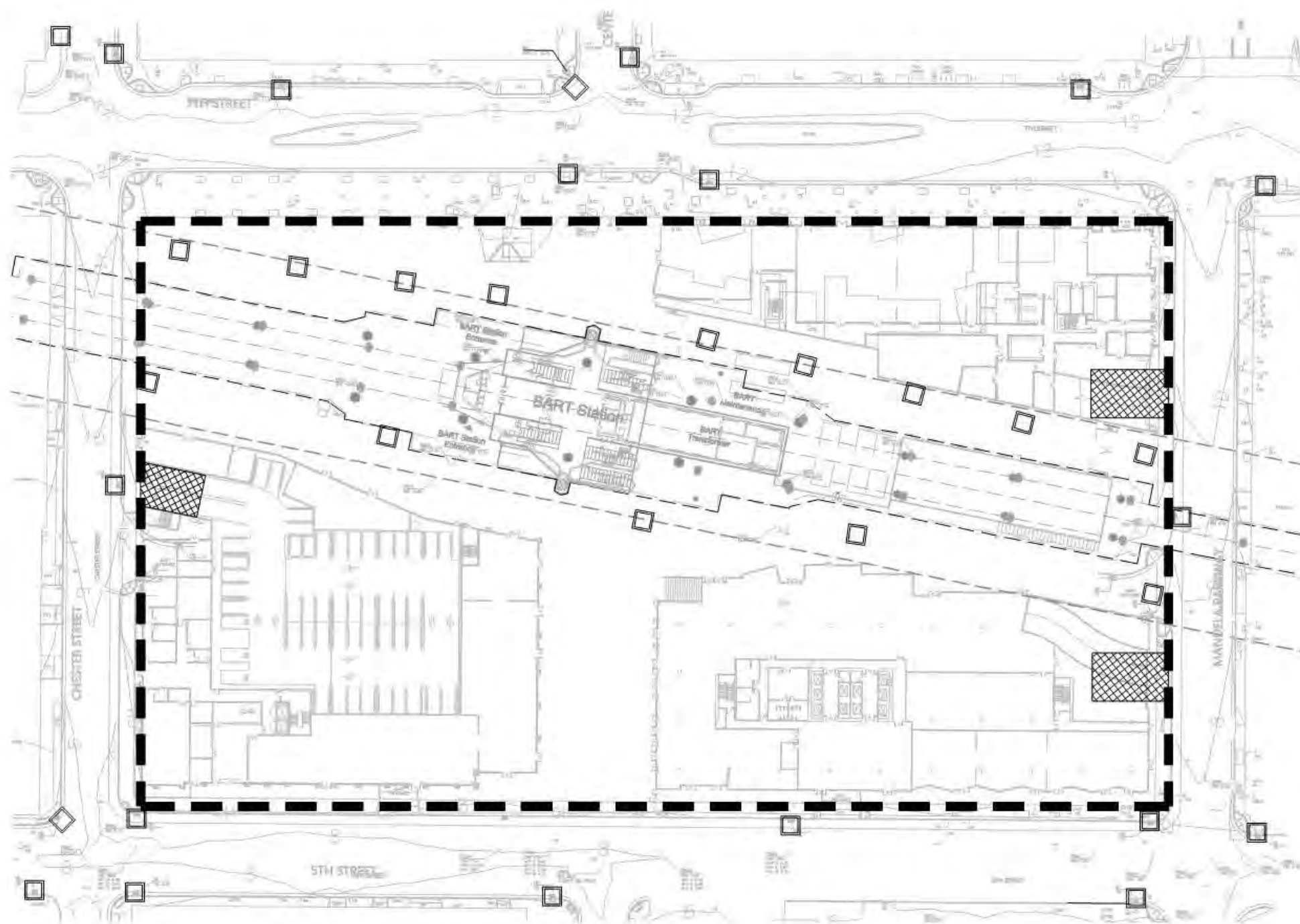

TOTAL SITE AREA (SF)	TOTAL LAND AREA DISTURBED (SF)	TOTAL EXISTING/PRE-PROJECT IMPERVIOUS SURFACE (SF)	REPLACED IMPERVIOUS SURFACE (SF)	NEW IMPERVIOUS SURFACE (SF)	TOTAL POST-PROJECT IMPERVIOUS SURFACE (SF)
243,130	243,130	212,865	177,410	25,135	202,545

DMA	Impervious Area (SF)	Pervious Area (SF)	Treatment Type	Designated Treatment Area
1	74,600	28,445	Filter Vault	T1
2	58,278	0	Filter Vault	T2
3	69,667	0	Filter Vault	T3
4	0	12,140	Permeable Paving	T4



**EROSION CONTROL LEGEND:**

-  STABILIZED CONSTRUCTION ENTRANCE (TC-1)\*\* WITH ENTRANCE/OUTLET TIRE WASH (TC-3)\*\*
-  STORM DRAIN INLET PROTECTION (SC-10)\*\*
-  FIBER ROLL (SC-05)\*\*

\*\*REFER TO SHEET C4.01 FOR DETAILS

**EROSION CONTROL NOTES:**

1. SITE ACCESS SHOWN ON THIS PLAN IS PROVIDED FOR INFORMATION PURPOSES ONLY. CONTRACTOR SHALL LOCATE CONSTRUCTION ACCESS DRIVEWAYS AS NECESSARY.
2. EROSION AND SEDIMENT CONTROL MEASURES SHALL BE IN EFFECT AND MAINTAINED BY THE CONTRACTOR ON A YEAR-ROUND BASIS UNTIL ALL DISTURBED AREAS ARE STABILIZED UNLESS OTHERWISE PERMITTED BY THE COUNTY INSPECTOR.
3. ALL INLETS RECEIVING STORM WATER RUNOFF FROM THE PROJECT AREA MUST BE EQUIPPED WITH REQUIRED INLET PROTECTION.
4. ALL PAVED AREAS SHALL BE KEPT CLEAR OF EARTH MATERIALS AND DEBRIS. THE SITE SHALL BE MAINTAINED SO AS TO MINIMIZE SEDIMENT LADEN RUNOFF ENTERING THE STORM DRAIN SYSTEM.
5. STOCKPILED EARTHEN MATERIAL SHALL BE EITHER COVERED WITH A TARP OR WATERED SUFFICIENTLY TO ELIMINATE DUST.
6. REFERENCE: "CALIFORNIA STORM WATER BEST MANAGEMENT PRACTICE (BMP) HANDBOOK", JANUARY 2015.



0 40 80



SCALE: 1" = 80'

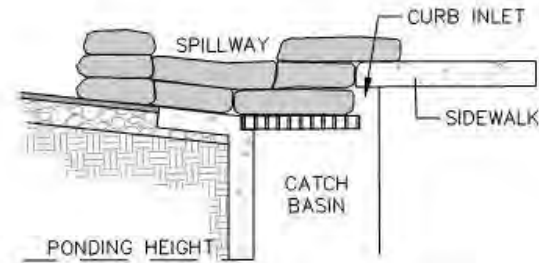
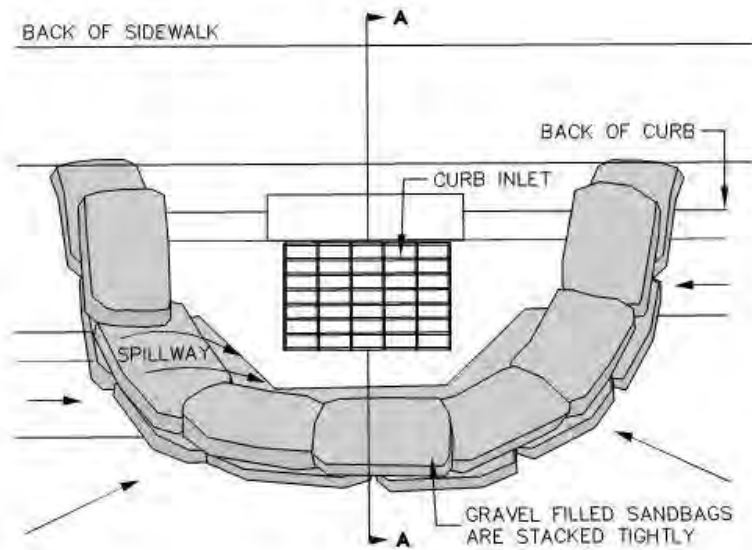

SECTION A-A

NOTES:

1. PLACE CURB TYPE SEDIMENT BARRIERS ON GENTLY SLOPING STREET SEGMENTS, WHERE WATER CAN POND AND ALLOW SEDIMENT TO SEPARATE FROM RUNOFF.
2. SANDBAGS OF EITHER BURLAP OR WOVEN 'GEOTEXTILE' FABRIC, ARE FILLED WITH GRAVEL LAYERED AND PACKED TIGHTLY.
3. LEAVE A ONE SANDBAG GAP IN THE TOP ROW TO PROVIDE A SPILLWAY FOR OVERFLOW.
4. INSPECT BARRIERS AND REMOVE SEDIMENT AFTER EACH STORM EVENT. SEDIMENT AND GRAVEL MUST BE REMOVED FROM THE TRAVELED WAY IMMEDIATELY.

① CURB INLET SEDIMENT BARRIER  
NOT TO SCALE

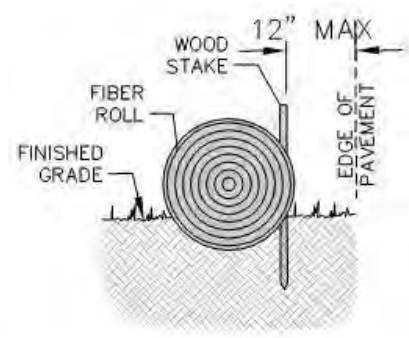

ENTRENCHMENT DETAIL  
IN FLAT AREA

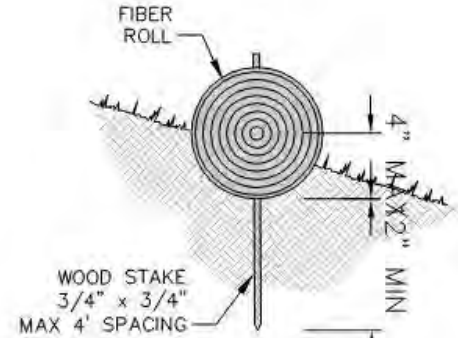

ENTRENCHMENT DETAIL  
IN SLOPED AREA

NOTES

1. FIBER ROLLS ARE TUBES MADE FROM POROUS BIODEGRADABLE FIBER STUFFED IN A PHOTO-DEGRADABLE OPEN WEAVE NETTING. THEY ARE APPROXIMATELY 8" DIAMETER.
2. FIBER ROLL INSTALLATION REQUIRES THE PLACEMENT AND SECURE STAKING OF THE ROLL IN A TRENCH; 2"-4" DEEP, DUG ON CONTOUR. RUNOFF MUST NOT BE ALLOWED TO RUN UNDER OR AROUND ROLL. ROLLS SHOULD BE ABUTTED SECURELY TO PROVIDE A TIGHT JOINT, NOT OVERLAPPED.

② FIBER ROLL  
NOT TO SCALE

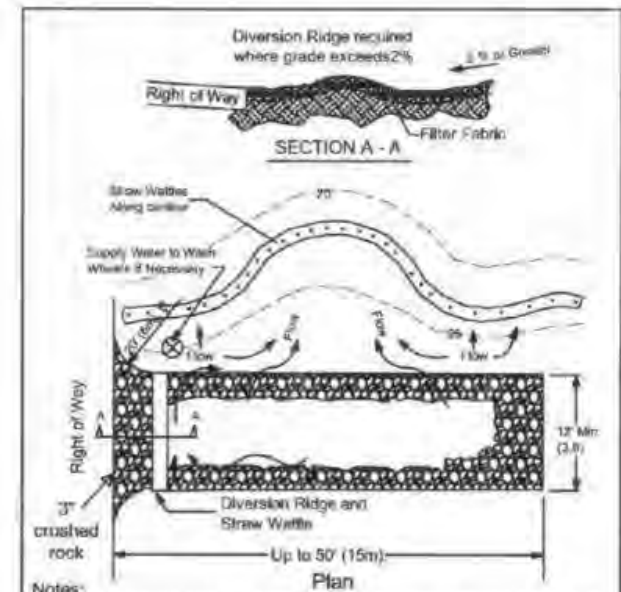

Notes:

1. The entrance shall be maintained to prevent sediment tracking or flowing onto public right-of-ways. This may require top dressing, repair and/or cleanout or other measures that trap sediment.
2. When necessary, wheels shall be cleaned prior to entering public right-of-way.
3. When washing is required, it shall be done on an area stabilized with crushed stone that drains into an approved sediment trap or sediment basin.

③ Site Entrance

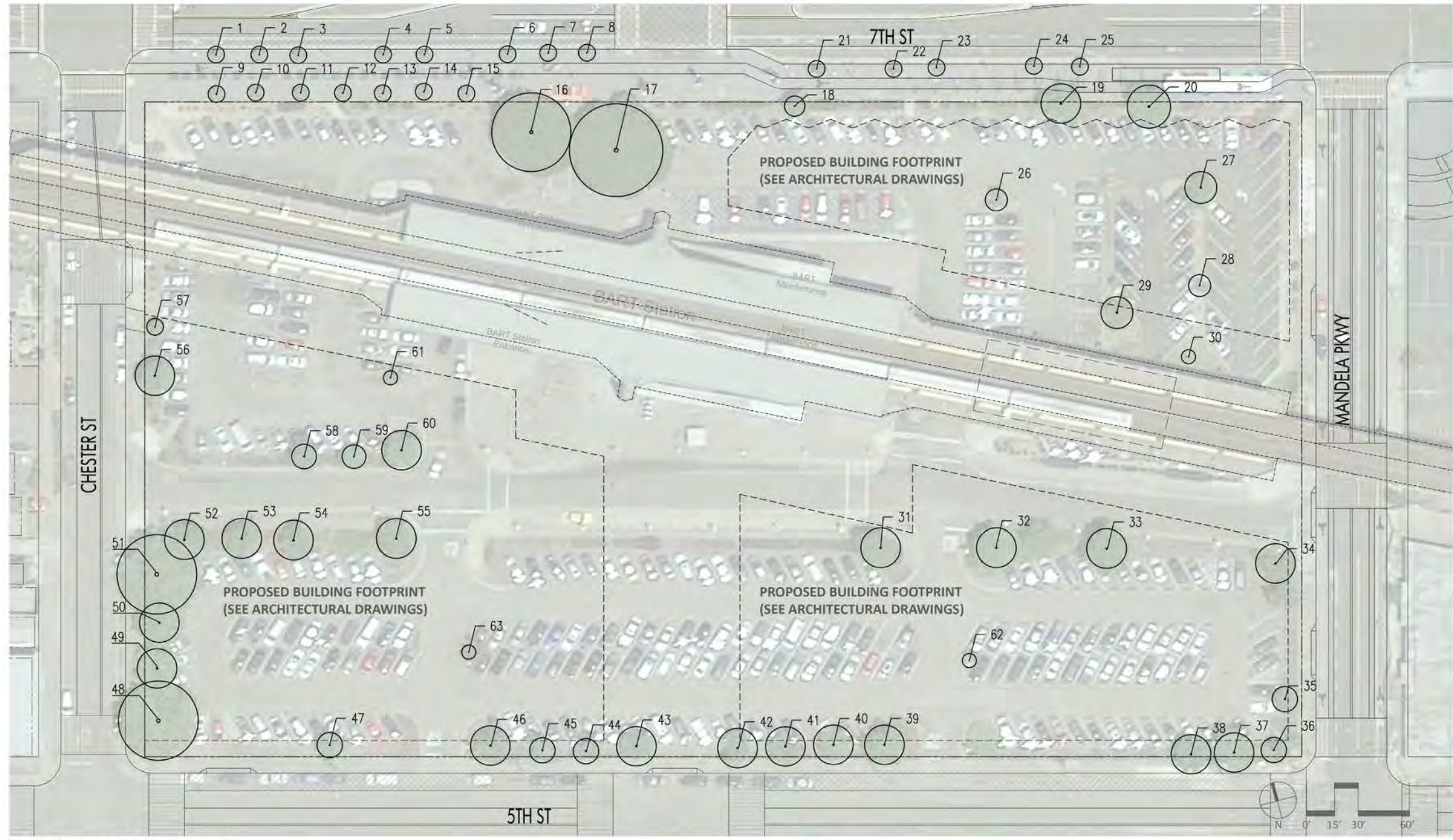

**Trees Proposed for Removal**

Key	Species	DBH (in)
1	<i>Pistacia chinensis</i>	4
2	<i>Pistacia chinensis</i>	4
3	<i>Pistacia chinensis</i>	4
4	<i>Pistacia chinensis</i>	3
5	<i>Pistacia chinensis</i>	5
6	<i>Pistacia chinensis</i>	4
7	<i>Pistacia chinensis</i>	4
8	<i>Pistacia chinensis</i>	4
9	<i>Pistacia chinensis</i>	4
10	<i>Pistacia chinensis</i>	4
11	<i>Pistacia chinensis</i>	4
12	<i>Pistacia chinensis</i>	4
13	<i>Pistacia chinensis</i>	4

Key	Species	DBH (in)
14	<i>Pistacia chinensis</i>	4
15	<i>Pistacia chinensis</i>	4
16	<i>Pinus pinea</i>	36
17	<i>Pinus pinea</i>	32
18	<i>Liriodendron tulipifera</i>	9
19	<i>Liriodendron tulipifera</i>	11
20	<i>Liriodendron tulipifera</i>	13
21	<i>Pistacia chinensis</i>	4
22	<i>Pistacia chinensis</i>	4
23	<i>Pistacia chinensis</i>	4
24	<i>Pistacia chinensis</i>	4
25	<i>Pistacia chinensis</i>	5
26	<i>Maytenus boaria</i>	7

Key	Species	DBH (in)
27	<i>Maytenus boaria</i>	12
28	<i>Maytenus boaria</i>	5
29	<i>Maytenus boaria</i>	16
30	<i>Maytenus boaria</i>	2
31	<i>Liriodendron tulipifera</i>	13
32	<i>Liriodendron tulipifera</i>	11
33	<i>Liriodendron tulipifera</i>	13
34	<i>Liriodendron tulipifera</i>	11
35	<i>Liriodendron tulipifera</i>	9
36	<i>Liriodendron tulipifera</i>	12
37	<i>Liriodendron tulipifera</i>	11
38	<i>Liriodendron tulipifera</i>	10
39	<i>Liriodendron tulipifera</i>	11

Key	Species	DBH (in)
40	<i>Liriodendron tulipifera</i>	9
41	<i>Liriodendron tulipifera</i>	10
42	<i>Liriodendron tulipifera</i>	10
43	<i>Liriodendron tulipifera</i>	9
44	<i>Liriodendron tulipifera</i>	7
45	<i>Liriodendron tulipifera</i>	8
46	<i>Liriodendron tulipifera</i>	8
47	<i>Liriodendron tulipifera</i>	9
48	<i>Platanus X acerifolia</i>	18
49	<i>Platanus X acerifolia</i>	10
50	<i>Platanus X acerifolia</i>	10
51	<i>Platanus X acerifolia</i>	17
52	<i>Liriodendron tulipifera</i>	12

Key	Species	DBH (in)
53	<i>Liriodendron tulipifera</i>	8
54	<i>Liriodendron tulipifera</i>	8
55	<i>Liriodendron tulipifera</i>	9
56	<i>Liriodendron tulipifera</i>	10
57	<i>Liriodendron tulipifera</i>	5
58	<i>Liriodendron tulipifera</i>	8
59	<i>Liriodendron tulipifera</i>	7
60	<i>Liriodendron tulipifera</i>	9
61	<i>Maytenus boaria</i>	5
62	<i>Maytenus boaria</i>	5
63	<i>Maytenus boaria</i>	7

**Bolded trees are protected trees.**

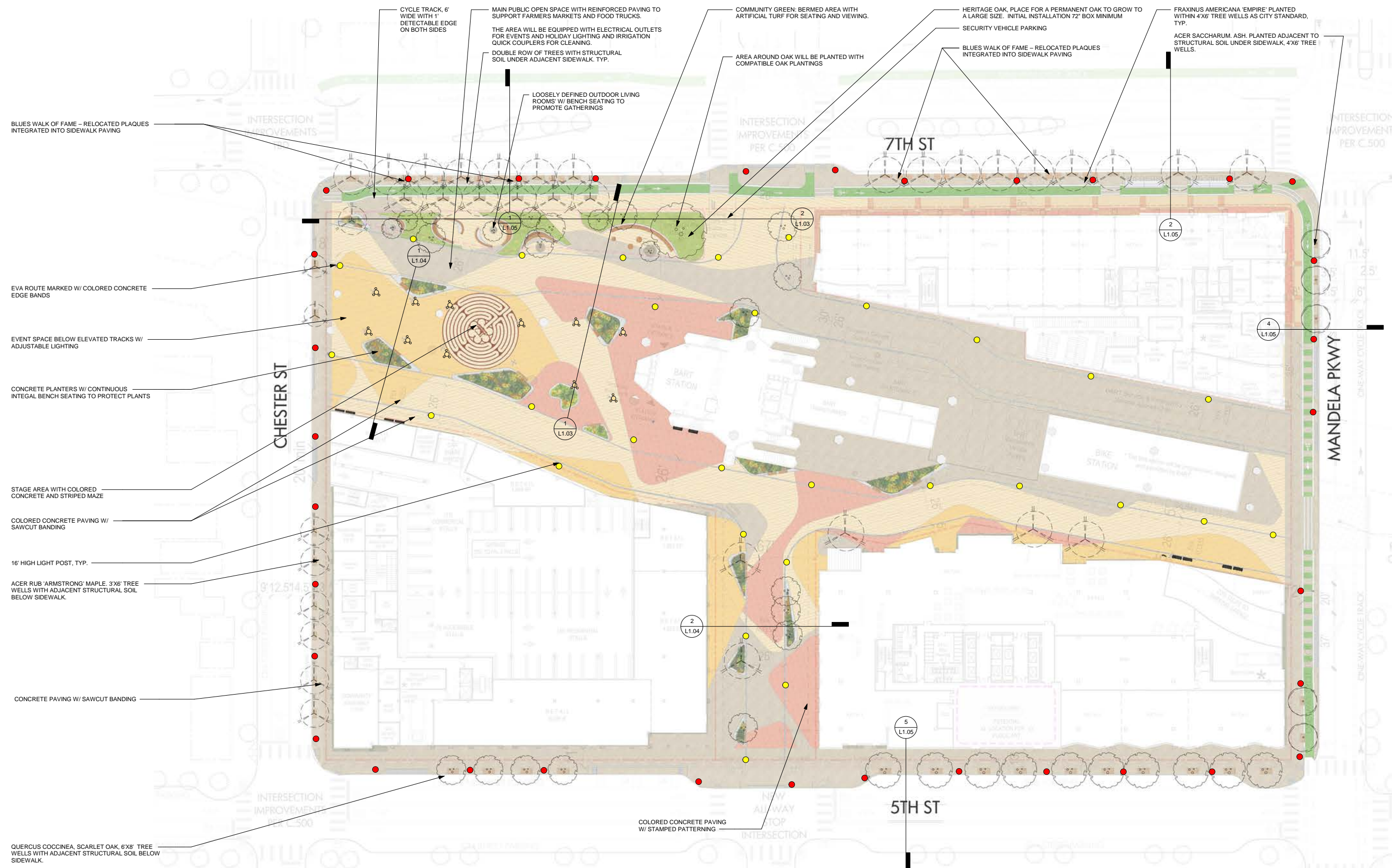

BLUES WALK OF FAME - RELOCATED PLAQUES INTEGRATED INTO SIDEWALK PAVING

EVA ROUTE MARKED W/ COLORED CONCRETE EDGE BANDS

EVENT SPACE BELOW ELEVATED TRACKS W/ ADJUSTABLE LIGHTING

CONCRETE PLANTERS W/ CONTINUOUS INTEGRAL BENCH SEATING TO PROTECT PLANTS

STAGE AREA WITH COLORED CONCRETE AND STRIPED MAZE

COLORED CONCRETE PAVING W/ SAWCUT BANDING

16' HIGH LIGHT POST, TYP.

ACER RUB 'ARMSTRONG' MAPLE 3'X6' TREE WELLS WITH ADJACENT STRUCTURAL SOIL BELOW SIDEWALK

CONCRETE PAVING W/ SAWCUT BANDING

QUERCUS COCCINEA, SCARLET OAK, 6'X8' TREE WELLS WITH ADJACENT STRUCTURAL SOIL BELOW SIDEWALK

THE PLAZA IS DESIGNED TO SUPPORT AND BALANCE THE NEEDS OF FUTURE USERS. THESE PATRONS WILL VARY FROM COMMUTERS TO THOSE COMING TO ATTEND LARGE EVENTS OR SIMPLY TO VISIT THE UNIQUE MARKETS. VARIOUS SIZED GATHERING SPACES ACCOMMODATE DIVERSE USES.

**IRRIGATION METHOD & WATER EFFICIENT LANDSCAPE ORDINANCE**

- IRRIGATION SYSTEM WILL BE DESIGNED TO PROVIDE THE MINIMUM AMOUNT OF WATER NECESSARY TO SUSTAIN GOOD PLANT HEALTH. ALL SELECTED COMPONENTS TO BE COMMERCIAL GRADE, SELECTED FOR DURABILITY, VANDAL RESISTANCE AND MINIMUM MAINTENANCE REQUIREMENT.
- THE SYSTEM WILL BE DRIPLINE IRRIGATION AS APPROPRIATE TO PLANT TYPE, EXPOSURE AND SLOPE CONDITIONS.
- CONTROL OF THE SYSTEM WILL BE VIA A WEATHER-ENABLED CONTROLLER CAPABLE OF DAILY SELF-ADJUSTMENT BASED ON REAL-TIME WEATHER CONDITIONS AS MEASURED BY AN ON-SITE WEATHER SENSOR.
- THE SYSTEM WILL INCLUDE A MASTER CONTROL VALVE AND FLOW SENSING CAPABILITY WHICH WILL SHUT DOWN ALL OR PART OF THE SYSTEM IF LEAKS ARE DETECTED.
- THE LANDSCAPE IS OVER 500 SQUARE FEET OF NEW LANDSCAPING AND WILL THEREFORE MEET THE REQUIREMENTS OF THE WATER EFFICIENCY LANDSCAPE ORDINANCE (WELO): [HTTPS://WATER.CA.GOV/LEGACYFILES/WATERUSEEFFICIENCY/LANDSCAPEORDINANCE/DOCS/TITLE%202023%20EXTRACT%20-%20OFFICIAL%20OCR%20PAGES.PDF](https://water.ca.gov/legacy/files/wateruseefficiency/landscapordinance/docs/title%202023%20EXTRACT%20-%20OFFICIAL%20OCR%20PAGES.PDF)

**WEST OAKLAND STATION CRIME PREVENTION THROUGH ENVIRONMENTAL DESIGN STRATEGIES**

- AREA LIGHTING:**
- ALL LOADING, UNLOADING, KISS AND RIDE, DROP OFF, PICK UP AREAS WILL BE LIT TO 5 CANDLE FOOT. SIDEWALKS AROUND THE SITE WILL BE LIT TO 1.25 CANDLE FOOT (CITY STANDARD), BIKE LOCKER AREAS WILL BE LIT TO 10 CANDLE FOOT, AND EXTERIOR PATRON WAITING AREAS OUTSIDE THE BART FAIR GATES WILL BE LIT TO 10 CANDLE FOOT. SEE SHEET L1.07 FOR MORE DETAIL REGARDING THE LOCATION OF THESE AREAS.
  - POLE LIGHTS ARE KEPT 20' CLEAR OF TREES AND LANDSCAPING. LIGHT POLES ARE LESS THAN 22' HIGH. OTHER LIGHTS WILL BE MOUNTED ON BUILDING, ON BOLLARDS OR ALONG OVERHEAD WIRES (<20' HIGH).
  - THE LIGHTING WILL USE A FULL COLOR INDEX IN ORDER TO BETTER DISTINGUISH FORM AND MOVEMENT.
- AREA PLANTING:**
- PLANTINGS, INCLUDING THE RAISED PLANTERS AND BERMS THEY ARE IN, WILL NOT EXCEED 36" IN HEIGHT. TREES WILL BE LIMBED UP TO 7' HIGH. THE INTENTION IS TO AVOID BLIND SPOTS CAUSED BY HIGH PLANTS AND PLANTERS. TREES WILL BE THE TYPE THAT RETAIN A THIN TRUNK AS THEY GROW AND MATURE. THE TREE CANOPIES WILL NOT BE OVERLY DENSE AND WILL ALLOW LIGHT IN FROM ABOVE.

- AREA SITE FURNISHINGS:**
- SITE FURNISHINGS, EARTH FORMS, AND ARTWORK WILL BE DESIGNED NOT TO OBSCURE VISIBILITY. BENCHES HAVE SEPARATORS/ARMRESTS, SO THEY ARE USED FOR SITTING ONLY. PLANTER BOXES AND LANDSCAPE WALLS WILL HAVE GROOVES OR ELEMENTS TO DETER SKATEBOARDERS. FENCES ARE DESIGNED TO RESIST TEMPERING AND CLIMBING.
- AREA SIGNAGE:**
- DIRECTIONAL AND WAYFINDING SIGNAGE WILL BE PLACED AT APPROPRIATE LOCATIONS TO HELP DIRECT THE VISITOR TO THEIR DESTINATION.
- SURVEILLANCE CAMERAS:**
- A SERIES OF SURVEILLANCE CAMERAS WILL BE PLACED TO COVER THE ENTIRE SITE. THESE CAMERAS WILL COMPLY WITH BART FACILITY STANDARDS.

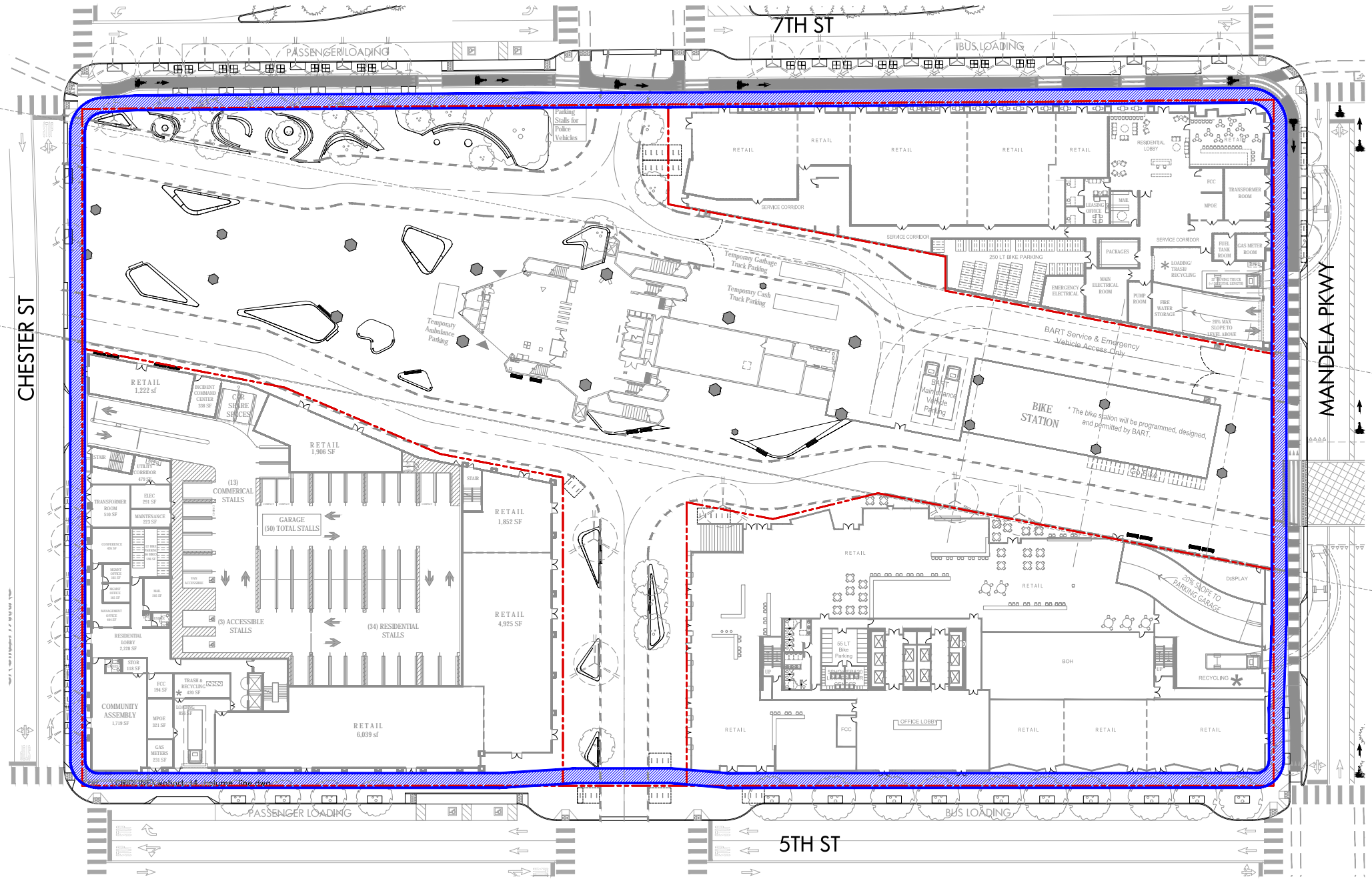

**LEGEND**  
 8' CLEAR ZONE FOR PEDESTRIAN  
 PROPERTY LINE

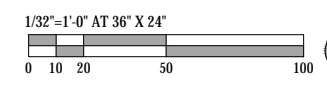



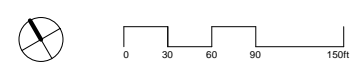
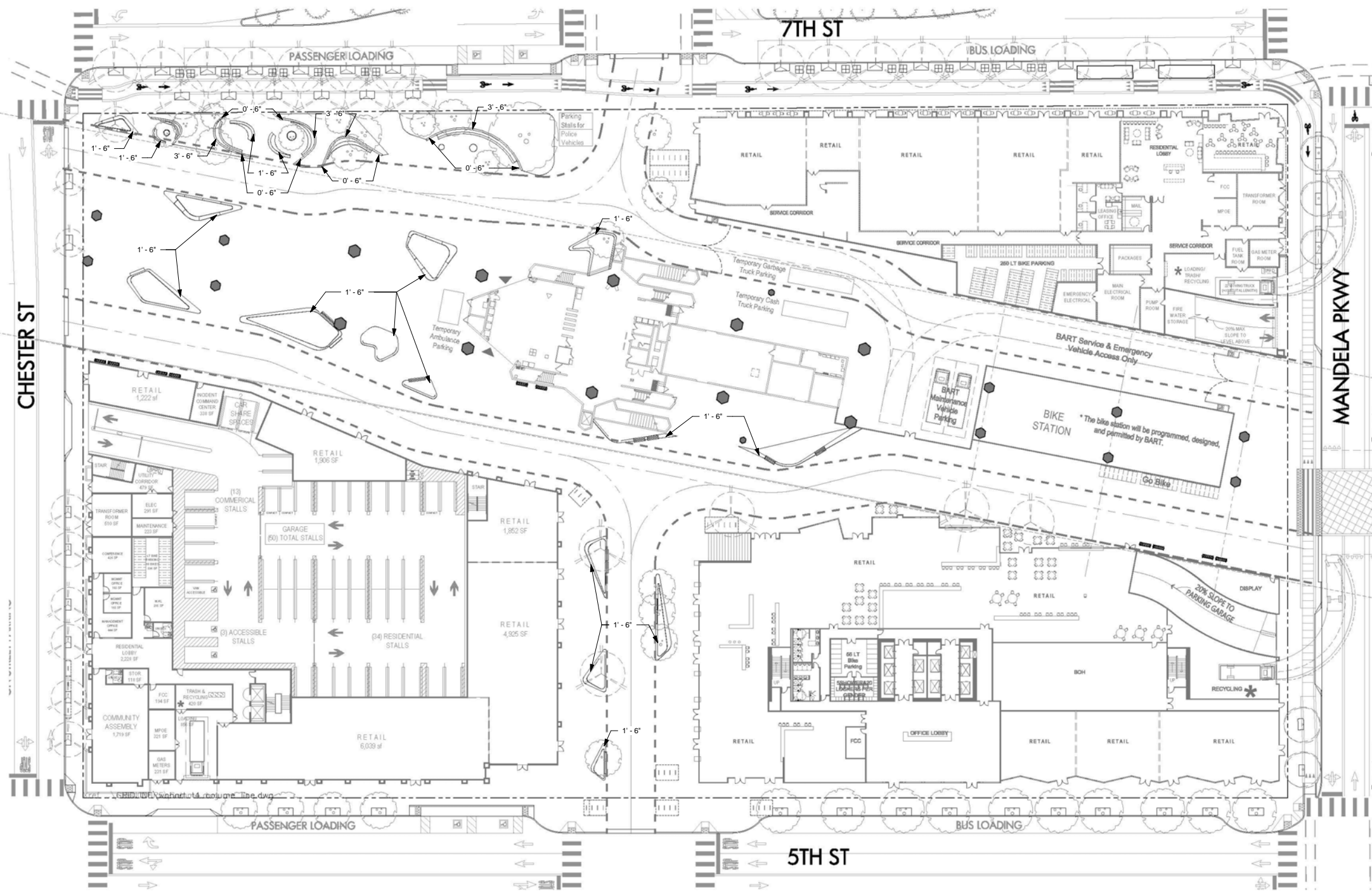

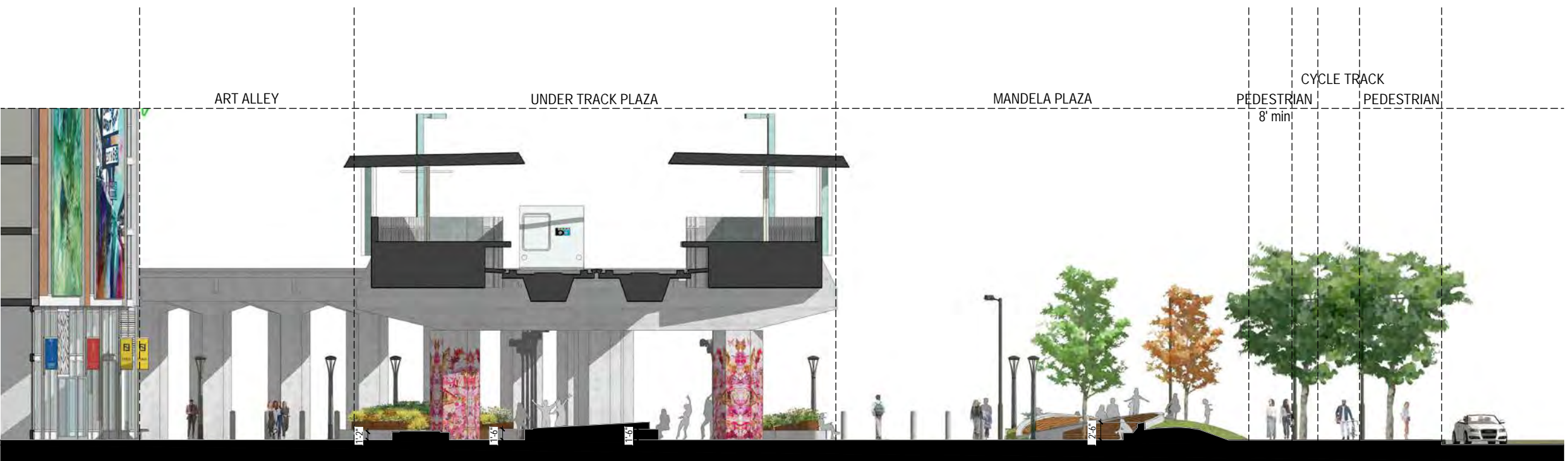

1 SECTION 1  
 L1.03 1/16" = 1'-0"



2 SECTION 2  
 L1.03 1/16" = 1'-0"



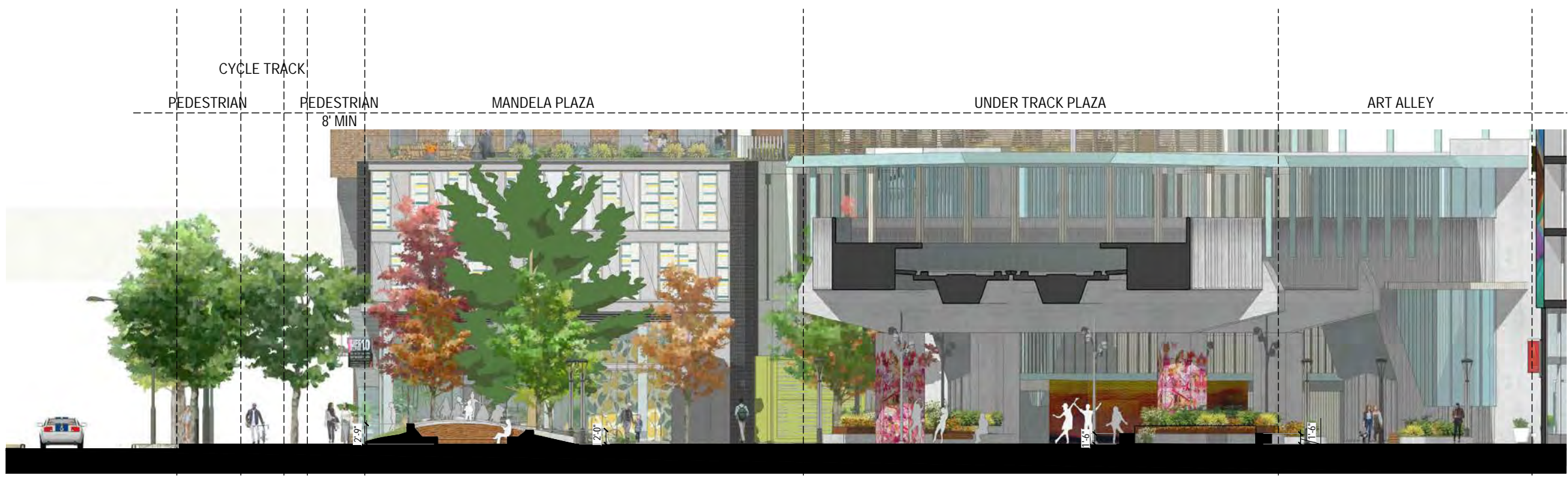

1 SECTION 3  
L1.04 1/16" = 1'-0"

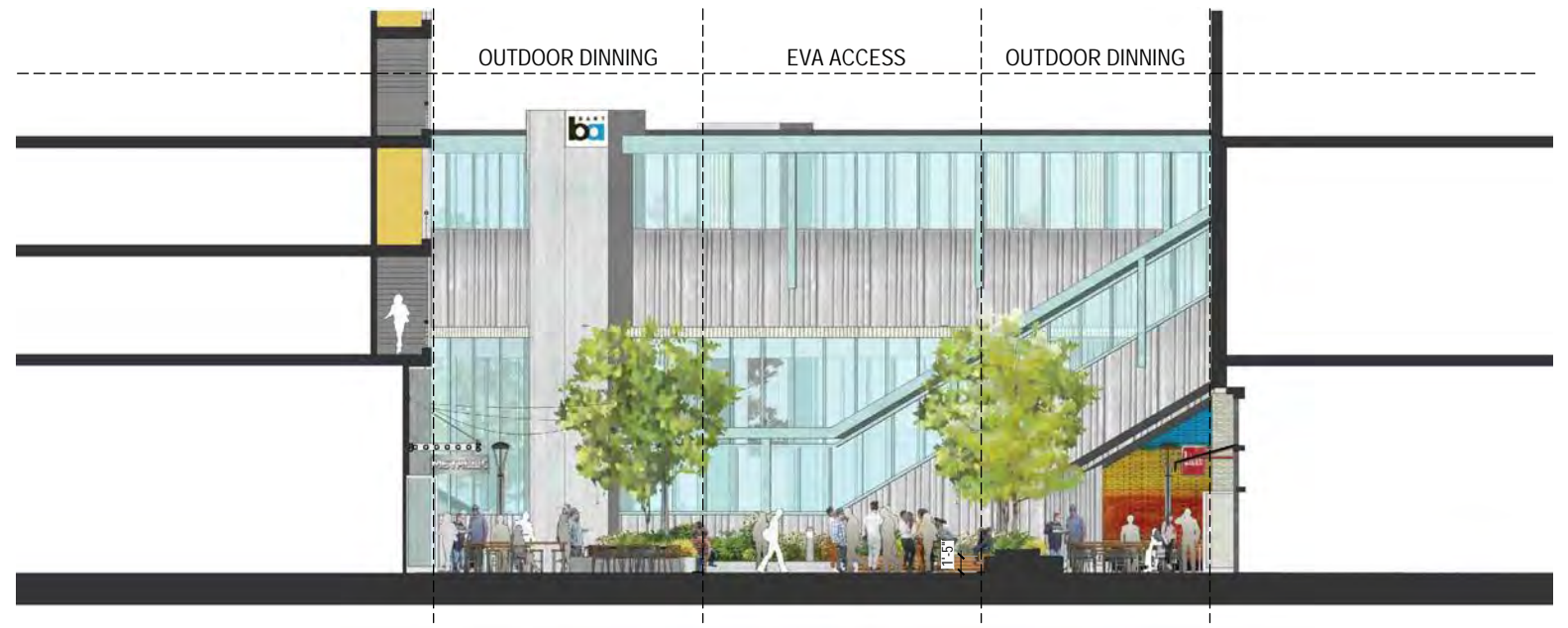

2 SECTION 4  
L1.04 1/16" = 1'-0"

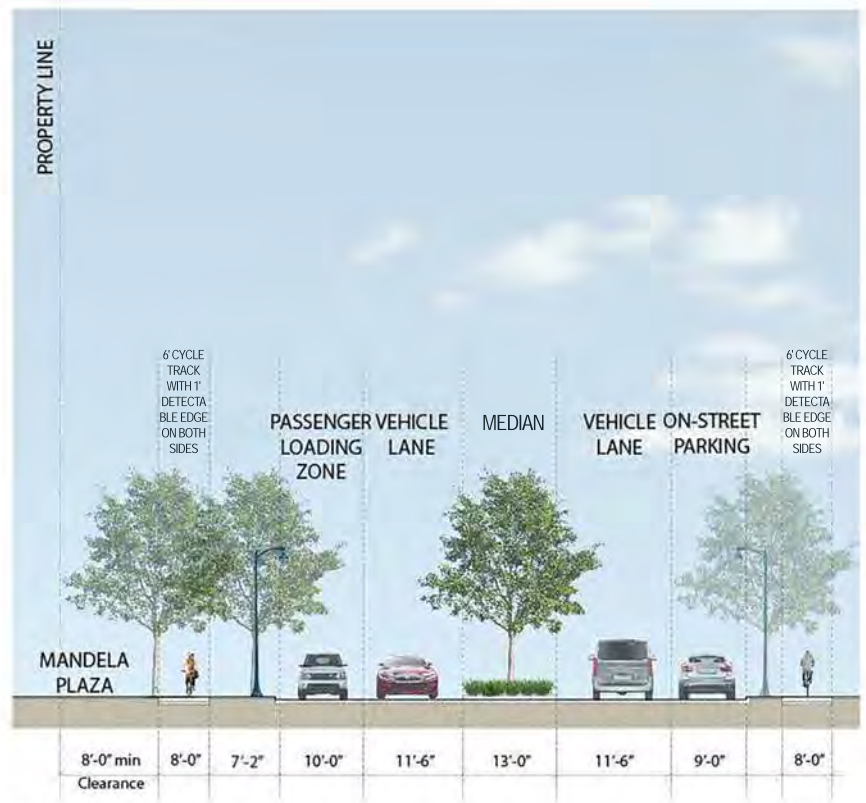

1 7TH STREET WEST SECTION  
 L1.05 1" = 20'-0"

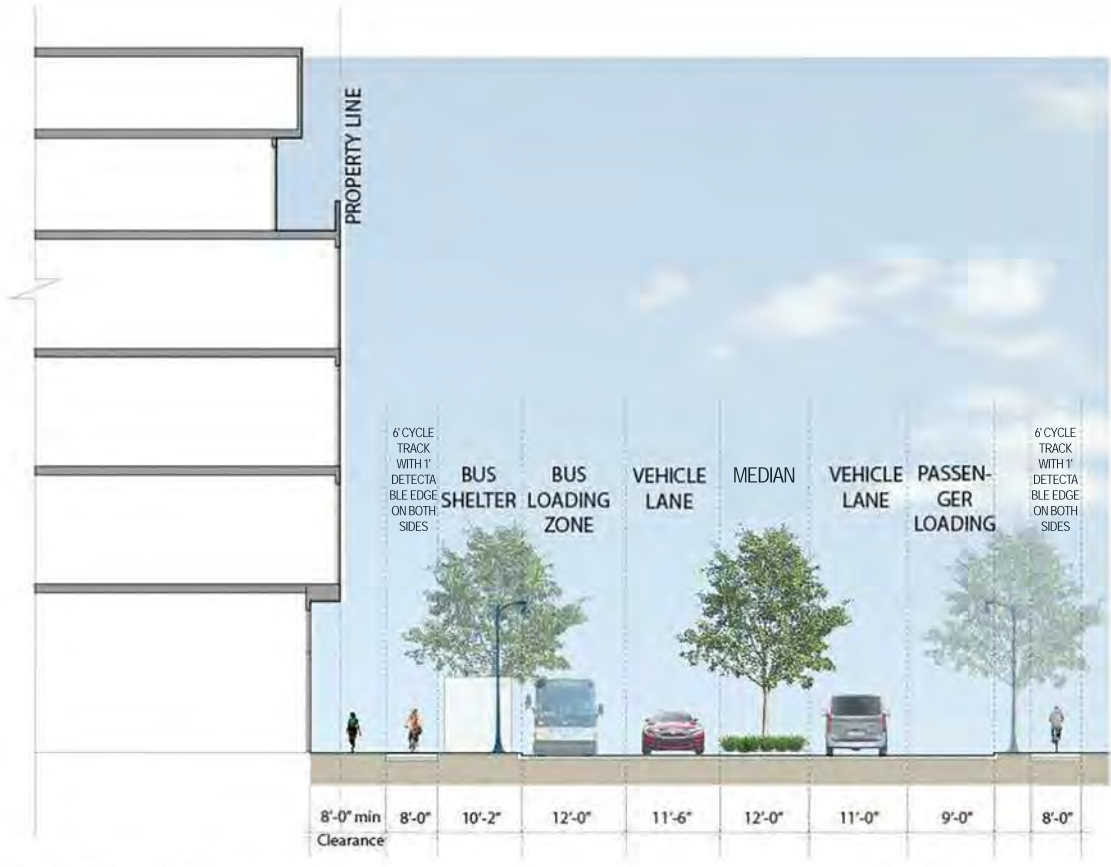

2 7TH STREET EAST SECTION  
 L1.05 1" = 20'-0"

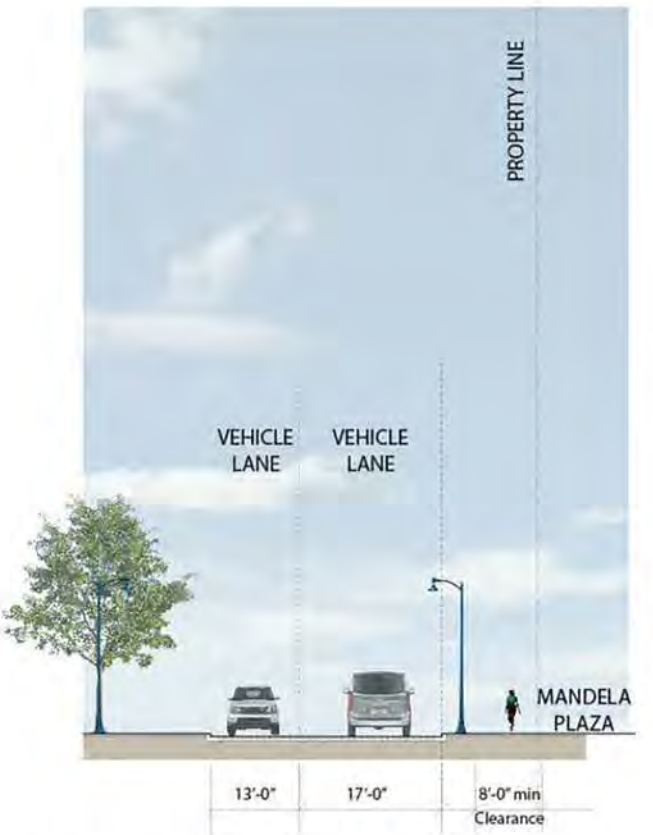

3 CHESTER STREET SECTION  
 L1.05 1" = 20'-0"

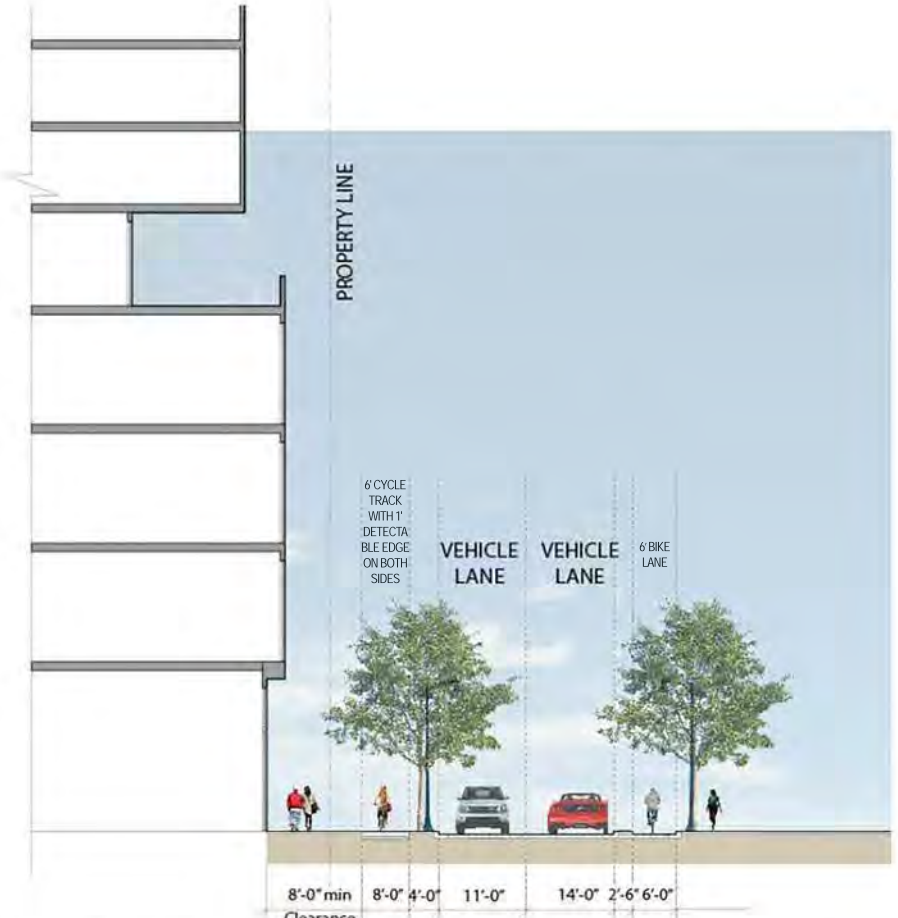

4 MANDELA PKWY SECTION  
 L1.05 1" = 20'-0"

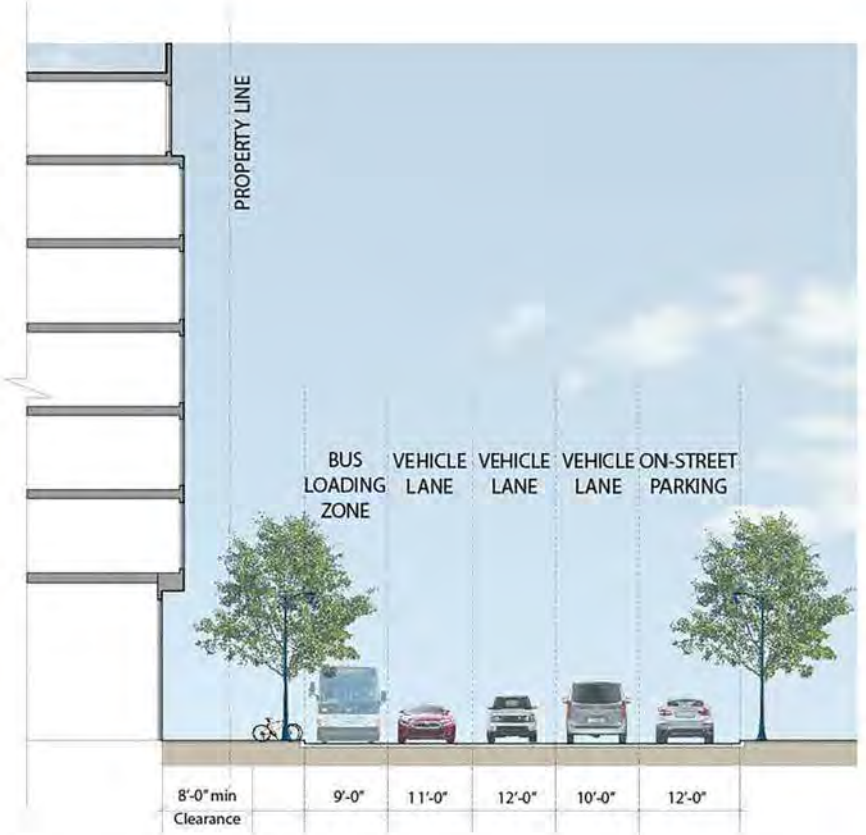

5 5TH STREET SECTION  
 L1.05 1" = 20'-0"

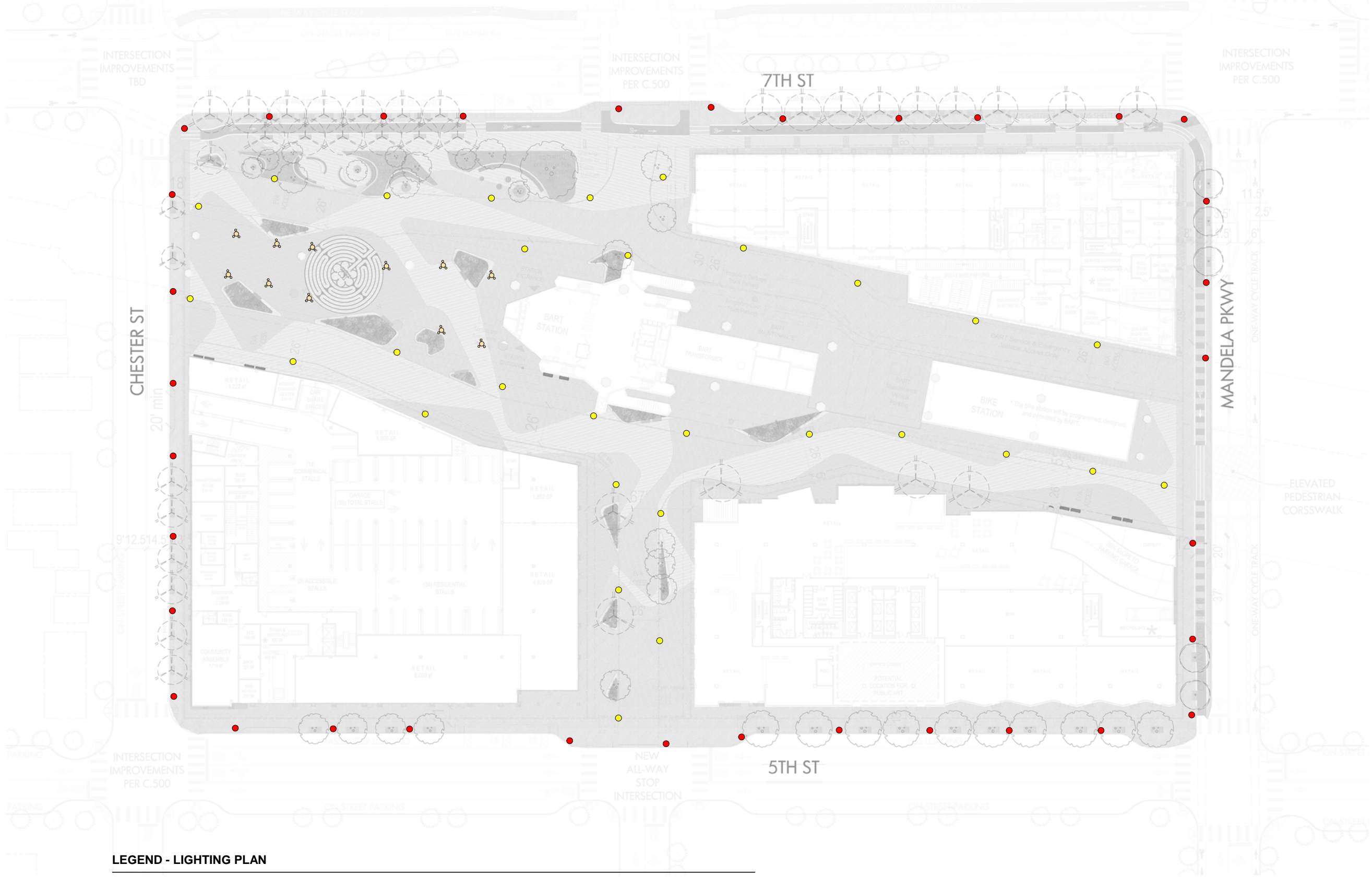

**LEGEND - LIGHTING PLAN**

- AREA LIGHTS FOR PLAZA
-  AREA LIGHTS WITH MULTIPLE HEADS FOR EVENT PLAZA
- STREET LIGHTS AS CITY REQUIRED

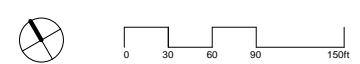

OWNER  
  
  

BUILDING T3  
 FDP PACKAGE

PROJECT  
**WEST OAKLAND BART**  
 1451 7th St, Oakland, CA 94607

ARCHITECT  
  
 JRDV Architects, Inc.  
 The Commercial Building  
 Broadway and Telegraph  
 Oakland, CA 94612 USA  
 (510) 288-4300 T  
 www.jrdv.com

PROJECT TEAM  
  
 BKF ENGINEERS  
 1646 N CALIFORNIA  
 BLVD, SUITE 400  
 WALNUT CREEK  
 CA 94596  
 (925) 940-3200  
  
 PGA DESIGN  
 444 17th Street  
 Oakland  
 CA 94612  
 (510) 465-1284  
  
 STOK  
 9458 Front Street  
 San Francisco  
 CA 94111  
 (415) 329-7100

STAMP

KEY

PROJ #: 168-153 WO BART  
 DATE: 03/26/20  
 SCALE: 1"=60' - 0"  
 TITLE:

**LIGHTING PLAN**

SHEET: **L1.06**



**PLANTING LEGEND**

<p><b>PLANTING ZONE 1: MANDELA PLAZA ENTRY</b></p> <ul style="list-style-type: none"> <li>CAREX DIVULSA</li> <li>NANDINA DOMESTICA ALBA 'LEMON-LIME'</li> <li>BERBERIS 'ORANGE ROCKET'</li> <li>IRIS DOUGLASIANA 'CANYON SNOW'</li> <li>MUHLENBERGIA DUBIA 'PINE MUHLY'</li> <li>PITOSPORUM TOBIRA 'MOJO'</li> <li>PHORMIUM 'YELLOW WAVE'</li> <li>CORDYLINE 'DESIGN-A LINE'</li> <li>DIGIPLIXIS ILLUMINATION 'APRICOT'</li> </ul>	<p><b>PLANTING ZONE 2: SHADE TOLERANT PLANTS BELOW BART TRACKS</b></p> <ul style="list-style-type: none"> <li>MAHONIA 'SOFT CARESS'</li> <li>MUHLENBERGIA DUBIA 'PINE MUHLY'</li> <li>BLECHNUM SPICANT 'DEER FERN'</li> <li>HELLEBORUS ARGUTIFOLIUS</li> <li>WOODWARDIA FIMBRIATA 'GIANT CHAIN FERN'</li> <li>CORDYLINE 'DESIGN-A LINE'</li> <li>EUPHORBIA CHARACIAS SSP.</li> <li>PHORMIUM 'YELLOW WAVE'</li> </ul>	<p><b>PLANTING ZONE 3: SOUTH FACING ALLEY</b></p> <ul style="list-style-type: none"> <li>CAREX DIVULSA</li> <li>MUHLENBERGIA DUBIA 'PINE MUHLY'</li> <li>IRIS DOUGLASIANA 'CANYON SNOW'</li> <li>MONARDELLA VILLOSA 'RUSSIAN RIVER'</li> <li>SALVIA SPATHACEA 'HUMMINGBIRD SAGE'</li> <li>SALVIA 'DARA'S CHOICE'</li> </ul>
--	--	---

PLEASE SEE RELATED IMAGES ON THE NEXT PAGE

OWNER  
**HEC**  
 HENSEL PHELPS  
 suda  
 T3  
 BUILDING T1  
 FDP PACKAGE  
 PROJECT

**WEST OAKLAND BART**  
 1451 7th St, Oakland, CA 94607

ARCHITECT  
**jrdv** ARCHITECTS  
 1000 Broadway, Suite 1000  
 Oakland, CA 94612  
 (415) 435-1000

PROJECT TEAM  
 BKP ENGINEERS  
 1548 INDIAN CREEK  
 WALNUT CREEK  
 CA 94596  
 (925) 940-2300  
 PDA DESIGN  
 444 17th Street  
 Oakland  
 CA 94612  
 (510) 465-1264  
 STOK  
 1400 First Street  
 San Francisco  
 CA 94111  
 (415) 329-7100

STAMP

KEY

PROJ # 168-163 WO BART  
 DATE 06/04/20  
 SCALE 1"=60' - 0"  
 TITLE **PLANTING ZONE**

SHEET **L1.07**

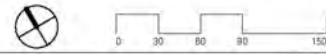

# TREES

## STREET TREES



ACER RUBRUM 'ARMSTRONG'



QUERCUS COCCINEA



AFROCARPUS FALCATUS



PISTACIA CHINENSIS

## PLAZA TREES



POPULUS DELTOIDES



CHITALPA TASHKENTENSIS



ALBIZIA JULIBRISSIN

# SHRUBS & GROUNDCOVER

## PLANTING ZONE 1 : ON THE PLAZA



CAREX DIVULSA



PHORMIUM 'YELLOW WAVE'



BERBERIS 'ORANGE ROCKET' 4'H X 2'W



NANDINA DOMESTICA  
ALBA 'LEMON-LIME' 4'H X 3'W



CORDYLINE 'DESIGN-A LINE' 3'X3'



PITTOSPORUM TOBIRA 'MOJO' 3'X3'



DIGIPLEXIS ILLUMINATION  
'APRICOT' 2'H X 18"W



IRIS DOUGLASIANA  
'CANYON SNOW'



MUHLENBERGIA DUBIA 'PINE MUHLY'

## PLANTING ZONE 2 : UNDER THE TRUCK



MAHONIA 'SOFT CARESS' 4'X4'



PHORMIUM 'YELLOW WAVE'



CORDYLINE 'DESIGN-A LINE' 3'X3'



EUPHORBIA CHARACIAS SSP.



BLECHNUM SPICANT 'DEER FERN'



WOODWARDIA FIMBRIATA 'GIANT CHAIN FERN'



HELLEBORUS ARGUTIFOLIUS 3'X3'



MUHLENBERGIA DUBIA 'PINE MUHLY'

## PLANTING ZONE 3 : IN THE ALLEY



MUHLENBERGIA DUBIA 'PINE MUHLY'



MONARDELLA VILLOSA  
'RUSSIAN RIVER'



IRIS DOUGLASIANA  
'CANYON SNOW'



SALVIA SPATHACEA  
'HUMMINGBIRD SAGE'



SALVIA 'DARA'S CHOICE'



CAREX DIVULSA

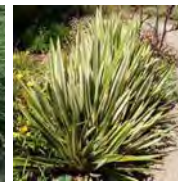

PHORMIUM 'TONY TIGER' 2.5'X2.5

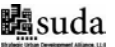

BUILDING T3  
FDP PACKAGE

PROJECT

WEST OAKLAND BART  
1451 7th St, Oakland, CA 94607

ARCHITECT



PROJECT TEAM



STAMP

KEY

PROJ # 168-153 WO BART

DATE 06/04/20

SCALE

TITLE  
LANDSCAPE  
PLANTS

SHEET:  
L1.08

**CAST-IN-PLACE CONCRETE PAVING**

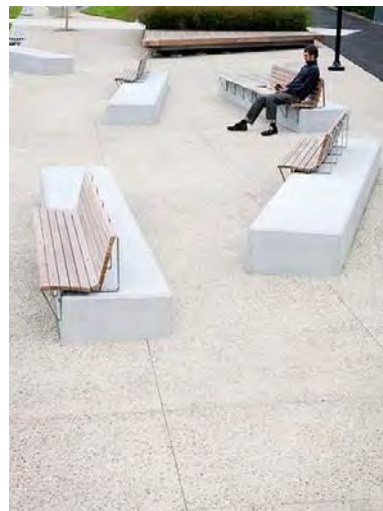

COLORED C.I.P w/ SAWCUT BANDING

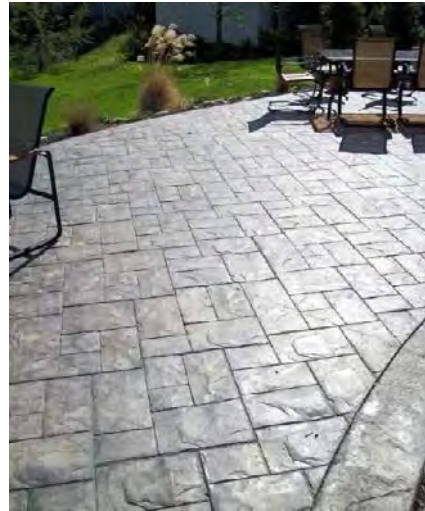

COLORED C.I.P w/ SAWCUT BANDING



C.I.P w/ SAWCUT BANDING

**NOTE:** ALL PAVING SHALL BE ADA COMPLIANT AND MINIMIZE UNDULATING AFFECTS WHEN TRAVELING OVER SURFACE

**PLANTER WALL**



POUR-IN-PLACE CONCRETE WITH SACK FINISH

**SITE FEATURES**



SLOPED TURF



EVENT PLAZA

**SITE FURNITURES**



BENCH: MODEL: NEW STANDARD BENCH, MANUFACTURER: STREETLIFE, TEL: 215.247.0148, WEBSITE: <https://www.streetlife.nl/us>



BIKE RACK: MODEL: BOLA BIKE RACK, MANUFACTURER: LANDSCAPEFORMS, TEL: 800.430.6209, WEBSITE: <https://www.landscapeforms.com/en-US>



TRASH BIN: MODEL: CHASE PARK LITTER, MANUFACTURER: LANDSCAPEFORMS, WEBSITE: <https://www.landscapeforms.com/en-US>



PICNIC TABLE SET: MODEL: GRETCHEN PICNIC TABLE, ADA COMPLIANT STYLE, MANUFACTURER: LANDSCAPE FORMS, TELEPHONE: 800.430.6209, WEBSITE: [WWW.LANDSCAPEFORMS.COM](http://WWW.LANDSCAPEFORMS.COM)

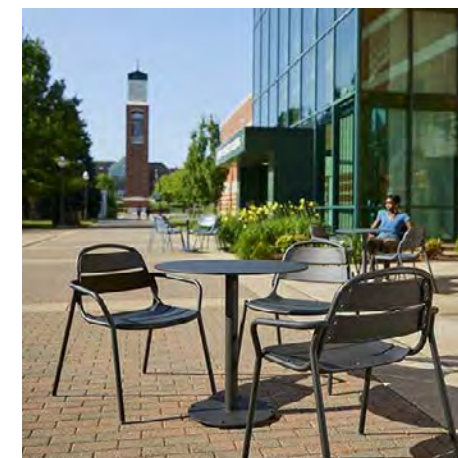

DINING TABLE & CHAIR SET: 21 CHAIR WITH ARMS BY LANDSCAPE FORMS, 4 CHAIRS PER TABLE, CATENA TABLE, 48" DIAMETER, NO UMBRELLA HOLE, ADA COMPLIANT QUAD SUPPORT LEGS, ADJUSTABLE GLIDES. FINISH: LANDSCAPE FORMS PROPRIETARY PANGARD II® POLYESTER POWDERCOAT COLOR: TBD FROM MANUFACTURER'S STANDARD PALETTE MANUFACTURER: LANDSCAPE FORMS, TELEPHONE: 800.430.6209, WEBSITE: [WWW.LANDSCAPEFORMS.COM](http://WWW.LANDSCAPEFORMS.COM)





Domus Luminaire



Manufacturer(s): Lumec
Catalog #: DMS50-HPS-SC3M-SMB-SCITX (Large Domus)
DOSHPS-5G3-SMB-SCITX-LMS (Small Domus)
Photometric File: 50105312.ies (Domus DMS50, 200-250W)
50206071.ies (Domus DOS, 35-150W)

Application: Domus DMS50 - Arterial and/or collector street lighting
Domus DOS - Residential street lighting and/or sidewalk side pedestrian lighting

Lamp Type: 35W, 100W, 150W, 250W HPS
Optical System: Type III
Ballast Voltage: Multi-tap 120/240V

Color: Teal Green only

Special Requirements:

Luminaire Cost: \$\$\$



As shown: Domus DOS luminaire w/ 3' arm on 16' octagonal pole.

Location: Coliseum Gardens



STREET LIGHTS

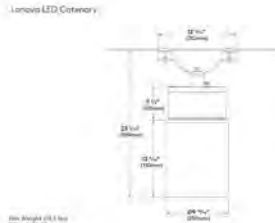

Specifications
Luminaire Housing/Hanger: One-piece stainless steel housing...
LED Driver: LEDs are driven by a full-bridge constant current LED driver...
LED Array: One-piece housing... LED array is mounted...
LED Optics: One or half (removal of) cylindrical acrylic cover...
5 Year Limited LED Luminaire Warranty...

OVERHEAD CABLE LIGHTS



PLAZA LIGHTS



landscape lighting

landscape lighting

ALCOTT AREA LIGHT Product Data Sheet



The Alcott Area Light is a contemporary re-interpretation of a traditional lamp... It features a high-quality finish and is constructed with durable materials...

General Description
Alcott Type 3
Alcott Type 5

Lighting facts tables for Alcott Type 3 and Alcott Type 5, including columns for Light Output, Power, Voltage, and Dimensions.



UZA-20001 Zaab 2 Single Side Cluster Column

Product page for UZA-20001, featuring a large image of the cluster column, technical drawings, and detailed specifications for construction, materials, and installation.

ALCOTT AREA LIGHT Product Data Sheet



The Alcott Area Light is a contemporary re-interpretation of a traditional lamp... It features a high-quality finish and is constructed with durable materials...

Lighting facts tables for Alcott Area Light, including columns for Product, Lamp, Drive Current, Color Temp, Input Voltage, and Mounting.



Other
ALCOTT is designed by Robert A.M. Stone Architects



BUILDING T3 FDP PACKAGE

PROJECT

WEST OAKLAND BART 1451 7th St, Oakland, CA 94607



PROJECT TEAM
BKF ENGINEERS
WALNUT CREEK
PGA DESIGN
STOK

STAMP

KEY

PROJ #: 168-153 WO BART
DATE: 06/04/20

TITLE: LIGHTING IMAGES

SHEET: L1.10



**LIGHTING PHOTOMETRIC GOALS**

AREA	FOOT CANDLE	LIGHT TYPE	CONTROLS
1. PEDESTRIAN WALKWAY	2 MIN	LED	POWER-LINE CARRIER TECHNOLOGY
2. EXTERIOR PATRON WAITING AREA	10	LED	DIMMABLE, TO REDUCE CONTRAST
3. BIKE LOCKER AREA	10	LED	SAME AS SURROUNDING SPACE
4. LOADING, UNLOADING, KISS-AND-RIDE AREAS, AND PEDESTRIAN WALKWAYS	5	LED	PHOTOCELL AND POWER-LINE CARRIER TECHNOLOGY OR WIRELESS CONTROL
5. OTHER EXTERIOR SPACES	1.25	LED	POWER-LINE CARRIER

**WEST OAKLAND BART**  
 4784# 城市/街 编号/地址: 793

ARCHITECT  
**jrdrv** ARCHITECTS  
 PROJECT TEAM  
 BKV ENGINEERS  
 BKF100  
 PDA DESIGN  
 STOK

STAMP  
 KEY  
 PROJ # 168-153-WO-BART  
 DATE 03/26/20  
 SCALE 1"=60'-0"  
 TITLE LIGHT LEVEL GOALS  
 SHEET L1.11





- 1. Outdoor dinning
- 2. Wood lounge platforms
- 3. Bench seating area
- 4. Lounge seating area
- 5. BBQ area
- 6. Gas fire pit
- 7. Children play area
- 8. Private deck
- 9. Small gathering platform

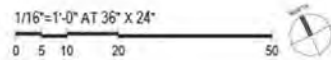

**BBQ AND OUTDOOR DINING AREA**



**CHILDRENS PLAY AREA**

**PODIUM PALETTE\_T3**

**AMENITIES**



ADA COMPLIANT OUTDOOR KITCHEN



SEATING WITH FIRE PIT



LOUNGE AREA WITH ADA COMPLIANCE  
COMMUNITY TABLE



DOG PARK



BOCCE COURT

**PAVING MATERIALS**

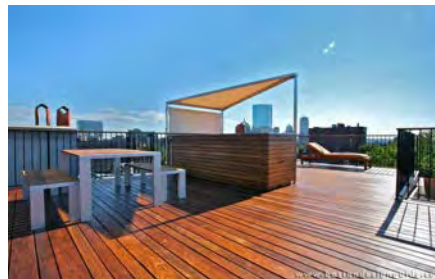

WOOD DECKING



STEPSTONE PAVERS

**SITE FURNISHINGS**



MOVABLE LOUNGE CHAIRS



SEATING ALONG PLANTER



PLANTERS



BUILT IN FURNISHINGS



DINING AREA



ARBOR



ACCESSIBLE PLAY STRUCTURES



**PLANTING PALETTE**



PHORMIUM 'DARK DELIGHT'



CEANOTHUS X PALLIDUS 'MARIE SIMON'



ANIGOZANTHOS 'BUSH GOLD'



KNIPHOFIA 'NANCY'S RED'



JUNCUS PATENS



VERBENA BONARIENSIS



NYALLA LOMANDRA



SENECIO MANDRALISCAE



ACER RUBRUM



CERCIS OCCIDENTALIS



ARBUTUS 'MARINA'



FEIJOA SELLOWIANA

OWNER  
 HEC  
 HENSEL PHELPS  
 suda  
 BUILDING T3  
 FDP PACKAGE

PROJECT  
**WEST OAKLAND BART**  
 1451 7th St, Oakland, CA 94607

ARCHITECT  
 jrdrv ARCHITECTS  
JRDRV Architects, Inc.  
 The Cathedral Building  
 Broadway and Telegraph  
 PO Box 70128  
 Oakland, CA 94612 USA  
 510 285 4382 T  
 www.jrdrv.com

PROJECT TEAM  
 BKF ENGINEERS  
1646 N. CALIFORNIA  
 BLVD., SUITE 400  
 WALNUT CREEK,  
 CA 94596  
 (925) 940-2200  
 PGAdesign  
424 17th Street  
 Oakland,  
 CA 94612  
 (510) 465-1284  
 STOK  
9408 Front Street  
 San Francisco  
 CA 94111  
 (415) 328-7100

STAMP  
 KEY

PROJ #: 168-153 WO BART  
 DATE: 06/04/20  
 SCALE:  
 TITLE:

**PODIUM  
 PALETTE\_T3**

SHEET: **L1.14**



1 - Mandela Plaza Center Street Entrance



2 - Artwalk from Center Street



3 - Undertrack Plaza from Artwalk



4 - Mandela Plaza Chester Street Entrance and Blues Walk of Fame

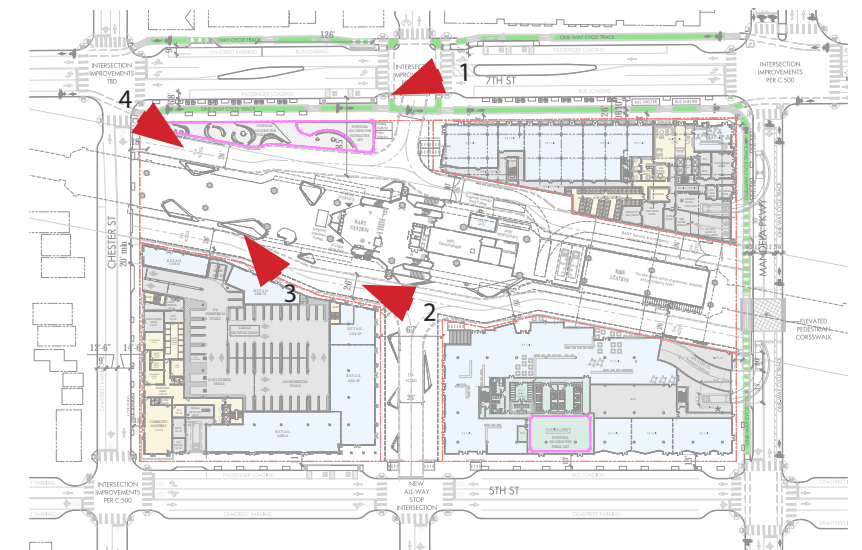

# Under Track Strategy

The Under-Track area is designed to integrate with both Mandela Plaza on 7th Street and Art Alley to the south. These combination of these spaces are planned to be programmed and perceived both separately and as linked spaces.

**Programmed Activation.** Under-Track area is designed as a flexible and activated space that will support food kiosks, exhibits and a wide range of staged events. The physical space of the Under-Track area serves these programmed activities by creating a defined space with high “ceiling” and significant scale, that is visually connected to the surrounding Public Spaces. The space also functions as an interesting urban plaza when no events are staged. It becomes an delightful and safe passage through the site.

**Landscape Paving.** The paving patterns are designed to define the space and encourage pedestrians to flow through the space. The variety of paving materials is designed to reduce the scale of the space, by implying nodes and clusters that can contain smaller groups or events. The paving pattern and variety of materials will also create a visually interesting plaza surface that does not require any activation or events.

**Seating.** Seating is provided with a combination of fixed-seating that is integrated into the planters. And, movable café-seating and tables to be placed and managed by specific events. The goal is to promote this space as both safe pedestrian passage through the site, and as a place to rest or participate in a planned event. The number of movable seats will be managed by the client and will respond to the actual demand.

**Lighting.** The lighting of the Under-Track area is designed to provide a high level of ambient light and “decorative” feature lighting. The ambient light is provided by a double row of 10’high light standards with a fixture that provide directional up-lighting and ground-lighting. Feature lighting will be provided with either fixtures attached to the BART structure, or fixtures attached to the light standards. This lighting will provide changeable artistically colored lighting that creates a powerful night presence that extends to the plaza and 7th Street. Lighting levels are designed to ensure visual safety for this space at all times.

**Decorative Surface Painting.** The columns of the BART structure may be painted with a surface graphic that is colorful and visually animates the space. This painted surface will create a delightful backdrop that will enhance the space for events and for the enjoyment of the public.



1 - From BART Station North Entrance



2 - From Art Walk



3 - From Mandela Plaza



4 - From Under Track Plaza

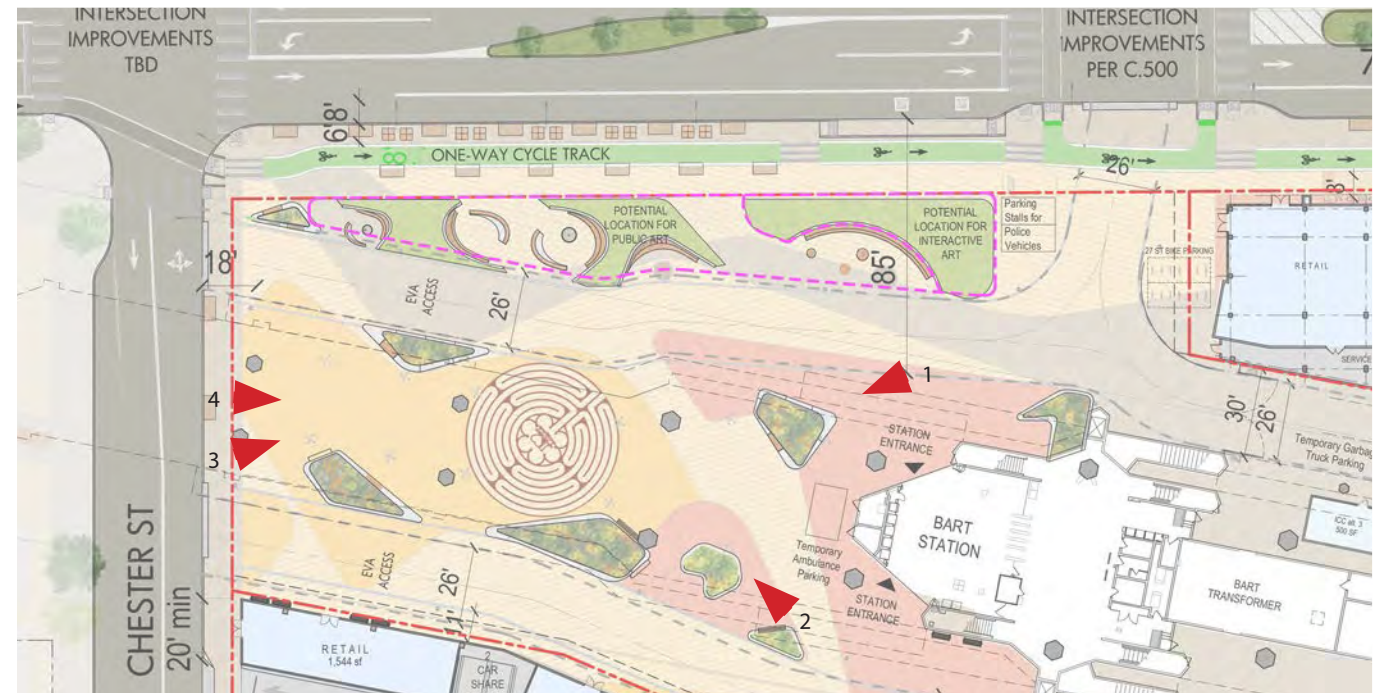

Partial Site Plan

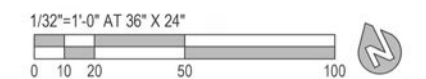

**Note:** Undertrack painting is optional pending BART’s approval.

# Public Space Programming and Activation

The Developer will provide regular programming in the public plazas of the proposed Mandela Station at West Oakland BART Station as required in the Conditions of Approval (COA #66) approved on February 6, 2019 by the City of Oakland Planning Commission. The purpose of the programming is to provide future BART riders, project-site residents, shoppers and workers, and the larger community of West Oakland with excellent opportunities to relax and enjoy as well as providing local businesses and non-profits to financially support themselves and promote their services and products.

Programmed events may include:

1. Concert events will be held on a monthly schedule in co-operation with the Developer and local non-profit Zoo Labs among others. Zoo Labs empowers music artists as leaders and directs resources toward their ventures.
2. Farmers Market events will be held monthly in collaboration with the Mandela Grocery Cooperative, a worker-owned grocery store that provides nourishing foods and enhanced opportunities for food vendors, including the Freedom Farmers Market weekly from July to November.
3. Local vendor Pop-Ups events will be held monthly and co-sponsored by PopUp Village. [popupvillage.org](http://popupvillage.org) features opportunities including:
  - Arts and Culture classes and exhibits
  - Food & Agriculture
  - Health & wellness
  - Youth Activities
  - Highlights local retail vendors
  - Performers of music, dance, spoken word
  - Education
  - These are a few of the collaborator of existing programs on 7th Street that as developers we intend to support and expand in collaboration with these organizations.

All program schedules and events will be advertised widely using: BART Station Public Information System, the networks of organizations that participated in the West Oakland Advisory Committee process and the local media outlets.



Community Art Fair



Local Farmers Market



Undertrack Program Events



Food Truck Events



Undertrack Program Events



Undertrack Program Events



Food Truck Events



Sunday Music Show

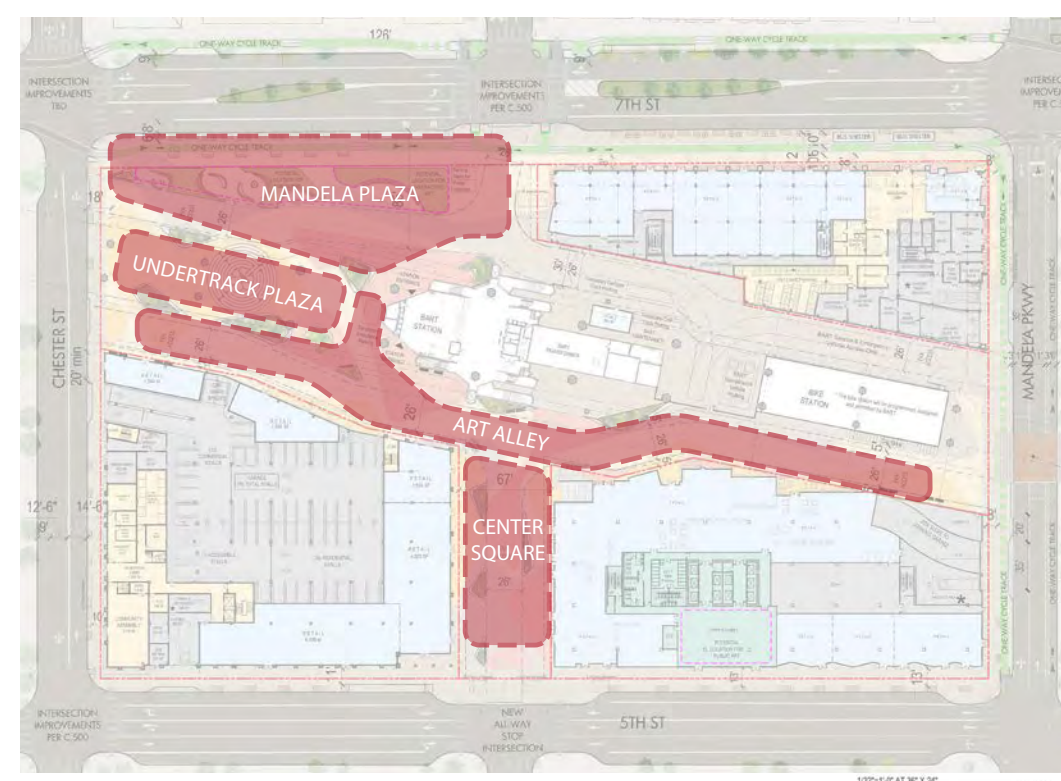

Public Open Space Map



5TH STREET ELEVATION OF T3 AFFORDABLE HOUSING

STEPPING DOWN FROM HEIGHT DENSITY TO LOW DENSITY





5TH STREET ELEVATION OF T3 AFFORDABLE HOUSING



CANAL DISTRICT, SLUSEHOLMEN, DENMARK



LICHTENBERG TOWNHOUSES, BERLIN, GERMANY

BREAKING DOWN THE FACADE VERTICALLY IN RESPONSE TO TRADITIONAL URBAN FABRIC



ART WALK ELEVATION



ART WALL REFERENCE



CENTER SQUARE ELEVATION

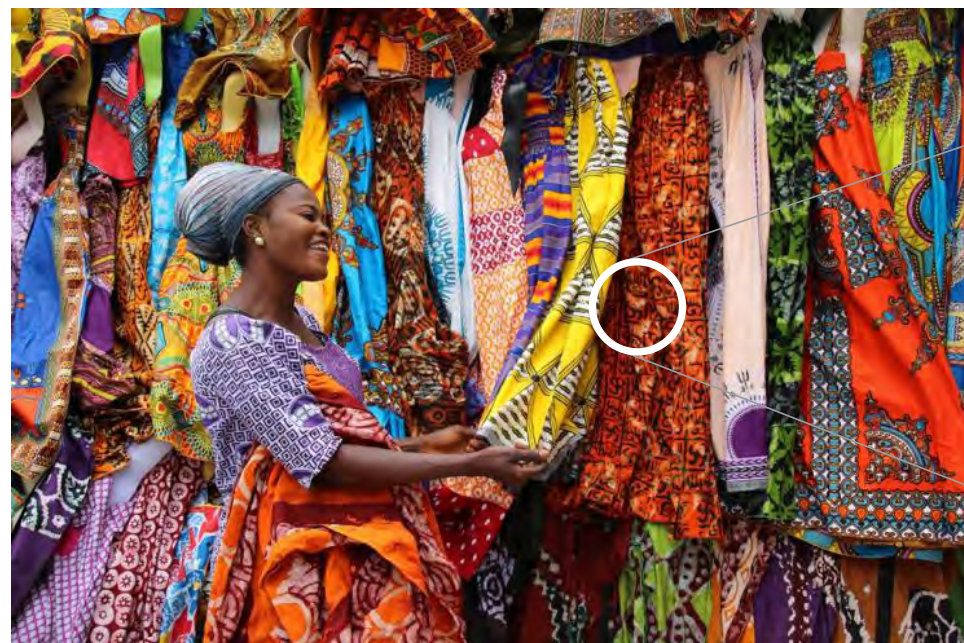

Wax, the Pan African Cloth

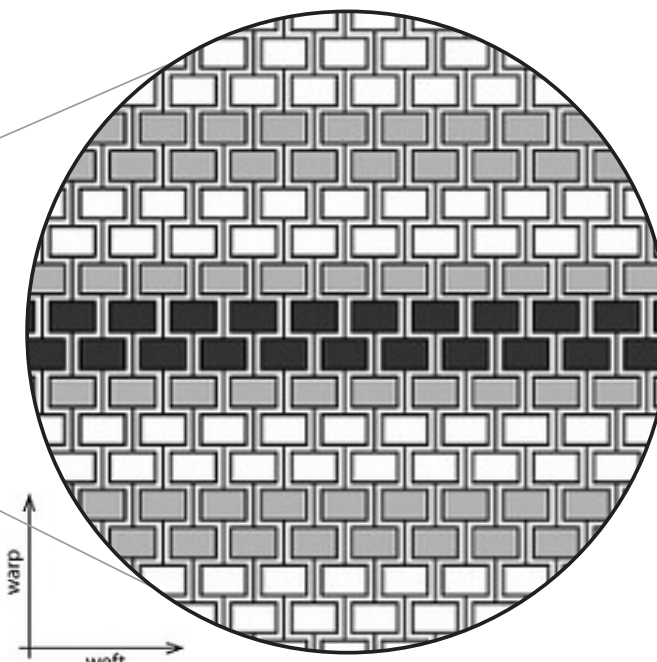
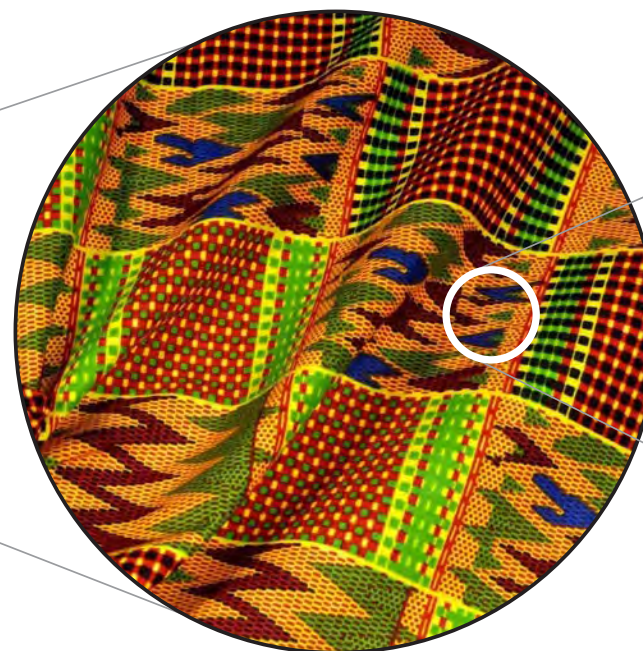

Weaving Construction

WEAVING CONSTRUCTION

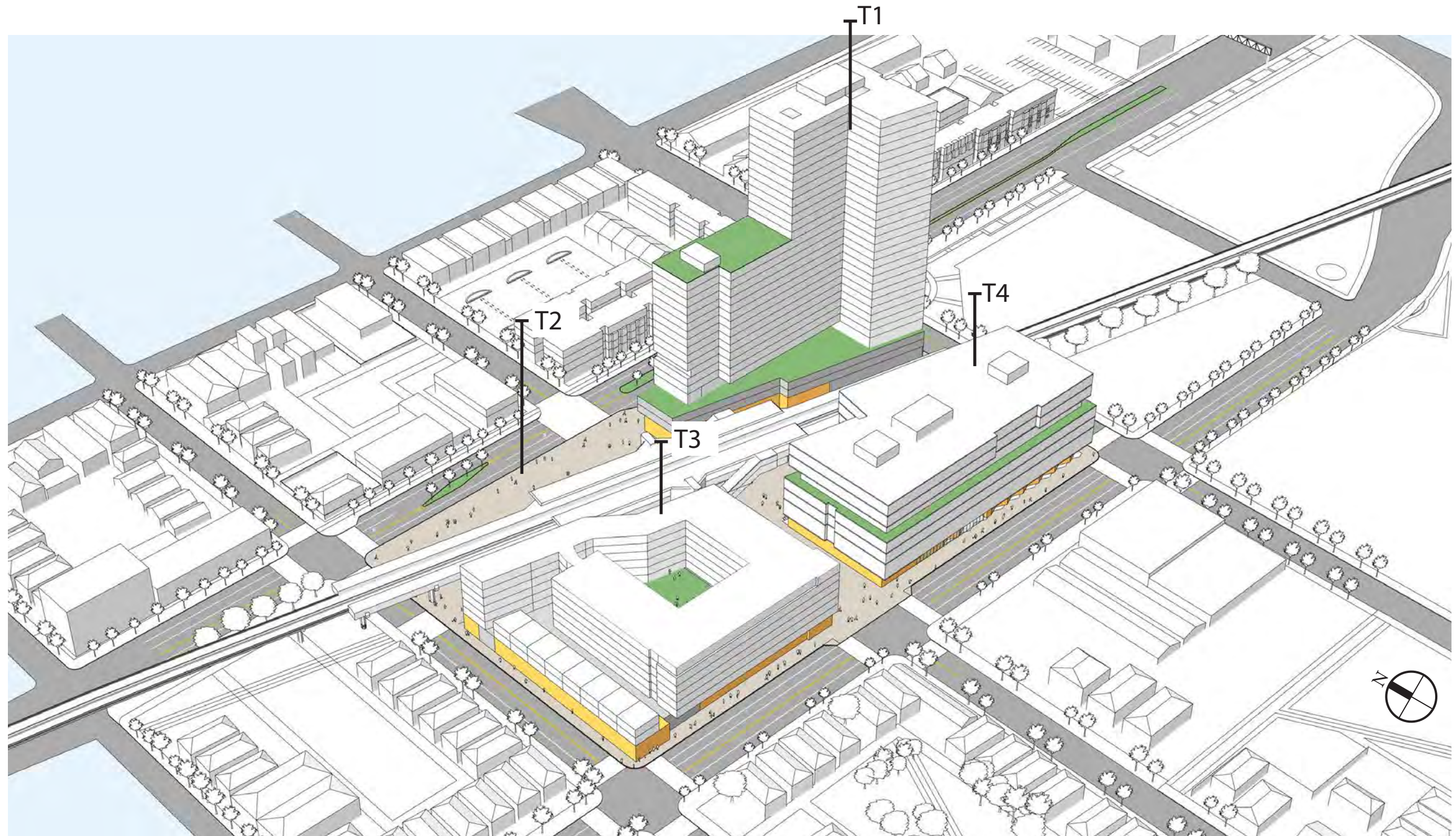

T3 RESIDENTIAL

<u>FLRS</u>	<u>F/F HGT.</u>	<u>FLR. ELEV.</u>
Roof		+80.0
7	10.0'	+70.0
6	10.0'	+60.0
5	10.0'	+50.0
4	10.0'	+40.0
3	10.0'	+30.0
2	10.0'	+20.0
1	20.0'	+0.0

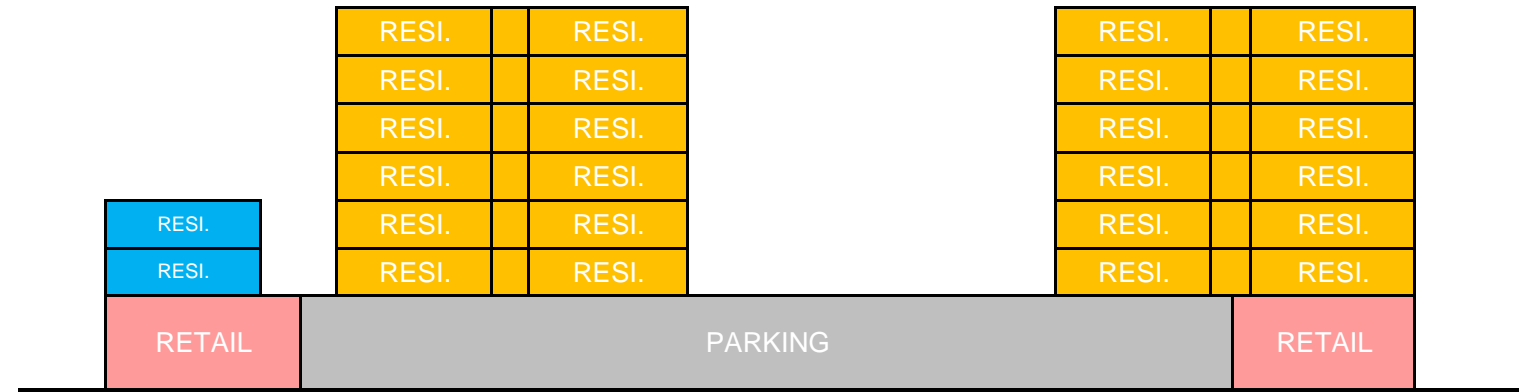

**COMBINED HOUSING UNITS MIX**

<u>FLRS</u>	<u>F/F HGT.</u>	<u>FLR. ELEV.</u>	<u>UNIT TYPE</u>	<u>1178 SF 3B</u>	<u>945 SF 2B</u>	<u>635 SF 1B</u>	<u>423 SF ST</u>	<u>Incident Command Center</u>	<u>Amenity Spaces GSF</u>	<u>Circulation &amp; BOH GSF</u>	<u>UNIT NSF</u>	<u>RES. GSF</u>	<u>EFF.</u>	<u>Retail Space GSF</u>	<u>PARKING SPACES</u>	<u>GSF</u>	<u>FLOOR AREA GSF</u>	<u>FLOOR AREA (PLANNING) GSF</u>	<u>TOTAL BRS</u>	
Roof		+80.0																		
7	10.0'	+70.0	39 unit	1 unit	8 unit	23 unit	7 unit			5,448 sf	26,466 sf	31,914 sf	82.93%				31,914 sf	31,914 sf		
6	10.0'	+60.0	39 unit	1 unit	8 unit	23 unit	7 unit			5,448 sf	26,466 sf	31,914 sf	82.93%				31,914 sf	31,914 sf		
5	10.0'	+50.0	39 unit	1 unit	8 unit	23 unit	7 unit			5,448 sf	26,466 sf	31,914 sf	82.93%				31,914 sf	31,914 sf		
4	10.0'	+40.0	39 unit	1 unit	8 unit	23 unit	7 unit			5,448 sf	26,466 sf	31,914 sf	82.93%				31,914 sf	31,914 sf		
3	10.0'	+30.0	43 unit	5 unit	8 unit	23 unit	7 unit			6,839 sf	31,389 sf	38,228 sf	82.11%				38,228 sf	38,228 sf		
2	10.0'	+20.0	41 unit	5 unit	7 unit	22 unit	7 unit		1,224 sf	7,172 sf	29,832 sf	38,228 sf	78.04%				38,228 sf	38,228 sf		
1	20.0'	+0.0						338 sf	1,838 sf	3,402 sf		6,833 sf		15,957 sf	50 stall	21,333 sf	23,128 sf	44,461 sf		
<b>TOTAL UNITS</b>				<b>3B</b>	<b>2B</b>	<b>1B</b>	<b>ST</b>	<b>GSF</b>	<b>GSF</b>	<b>GSF</b>	<b>NSF</b>	<b>GSF</b>		<b>GSF</b>	<b>SPACES</b>	<b>GSF</b>	<b>GSF</b>	<b>GSF</b>	<b>TOTAL BEDROOMS</b>	
				<b>240 unit</b>	<b>14 unit</b>	<b>47 unit</b>	<b>137 unit</b>	<b>42 unit</b>	<b>338 sf</b>	<b>3,062 sf</b>	<b>39,205 sf</b>	<b>167,085 sf</b>	<b>210,945 sf</b>		<b>15,957 sf</b>	<b>50 stall</b>	<b>21,333 sf</b>	<b>227,240 sf</b>	<b>248,573 sf</b>	<b>323 bedrooms</b>

# T3 SOUTH / 5TH STREET ELEVATION



## 7TH FLOOR

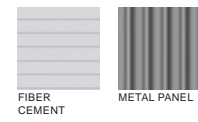
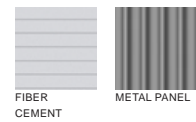
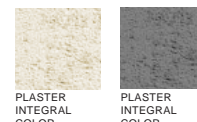
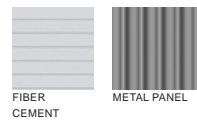

## 2-6TH FLOOR

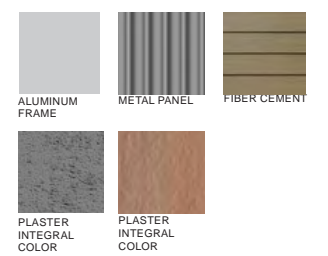
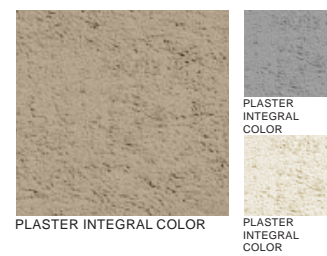
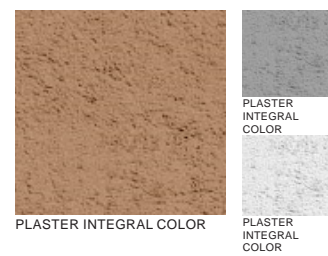
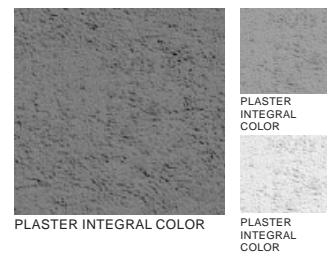
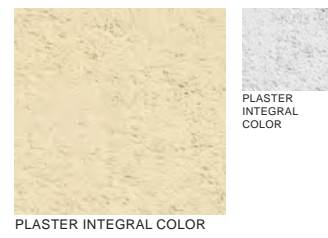

## GROUND FLOOR



## WINDOW SYSTEM

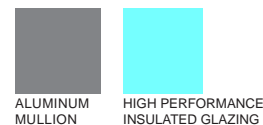

## BALCONY

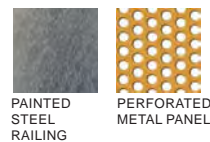

## STOREFRONT SYSTEM

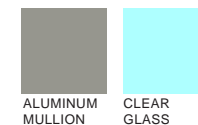

## BASE



# T3 EAST / CENTER SQUARE ELEVATION

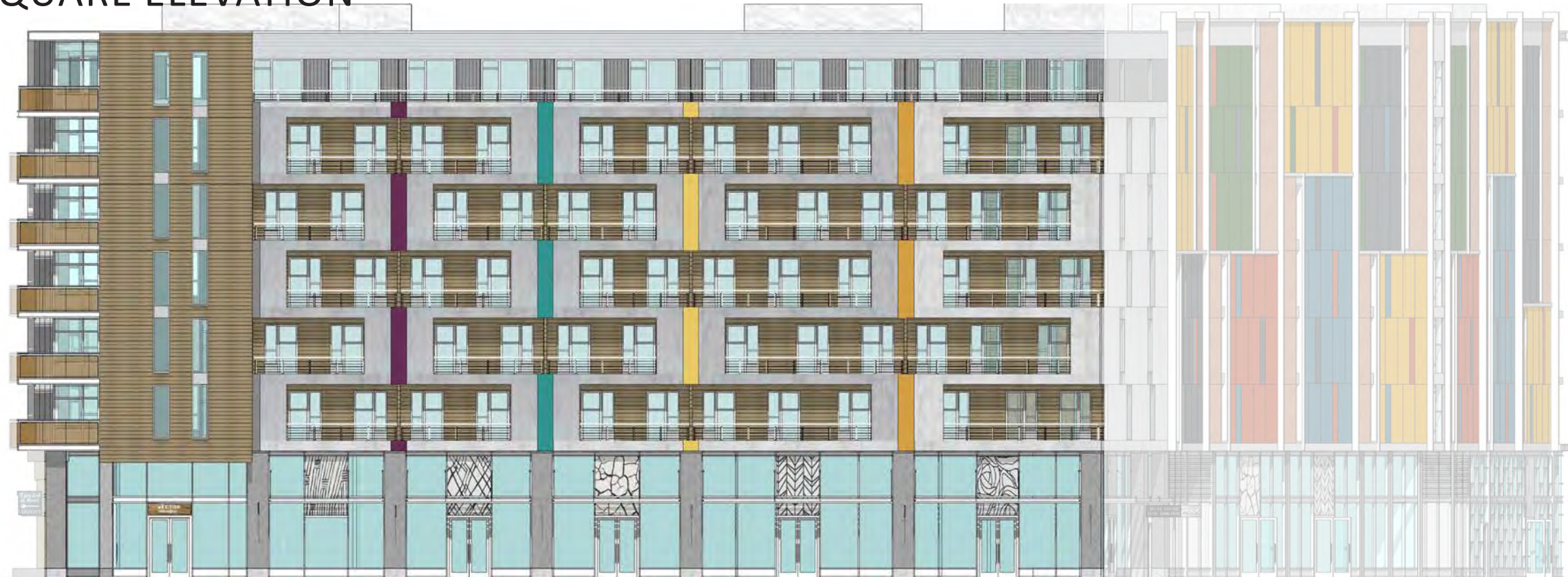

## 7TH FLOOR

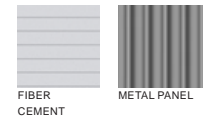

## 2-6TH FLOOR

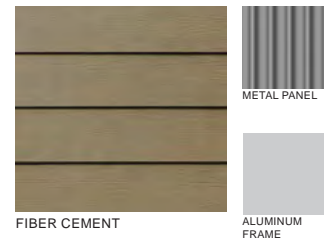

## GROUND FLOOR



## WINDOW SYSTEM

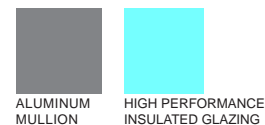

## BALCONY

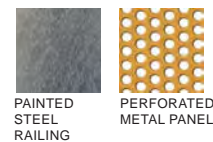

## STOREFRONT SYSTEM

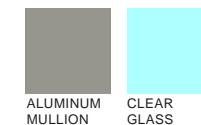

## BASE



# T3 NORTH / ART ALLEY ELEVATION

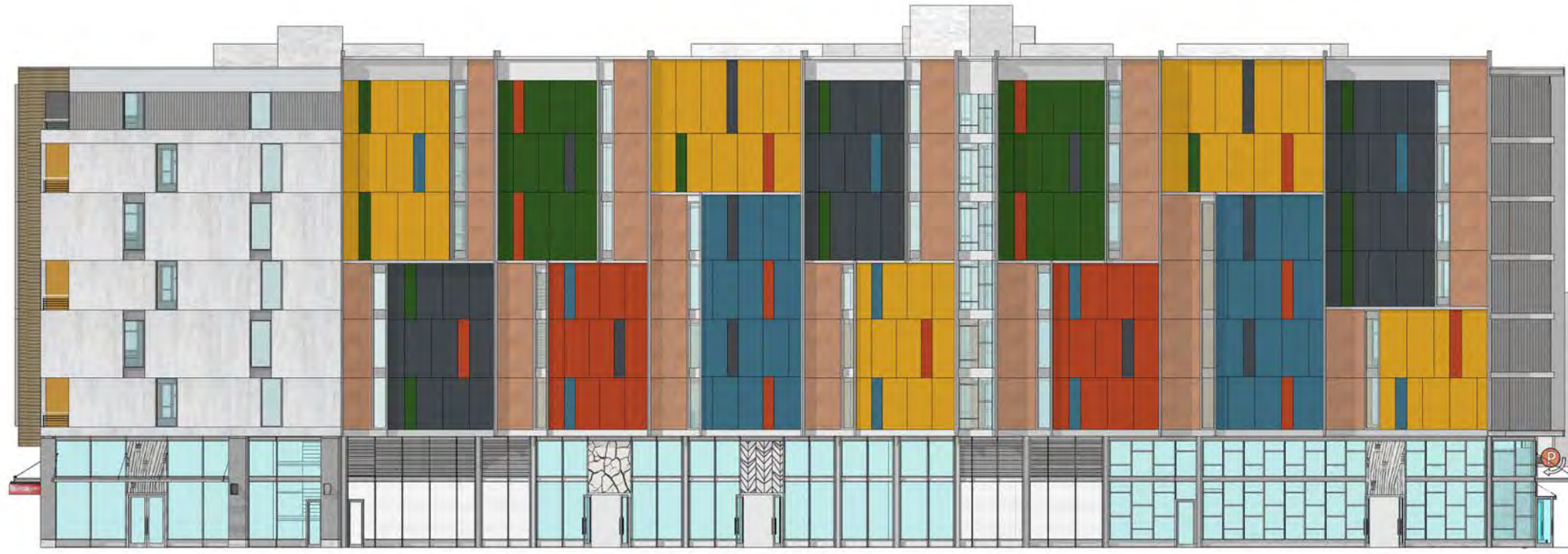

<p><b>7TH FLOOR</b></p>  <p>FIBER CEMENT</p>  <p>METAL PANEL</p>	<p><b>2-6TH FLOOR</b></p>  <p>CEMENT PLASTER</p>  <p>3-COAT CEMENT PLASTER SYSTEM</p>  <p>METAL PANEL</p>  <p>ACM ALUMINUM COLORED PANEL</p>  <p>ALUMINUM FRAME</p>  <p>METAL PANEL</p>	<p><b>GROUND FLOOR</b></p>  <p>BRICK TILE</p>	<p><b>WINDOW SYSTEM</b></p>  <p>ALUMINUM MULLION</p>  <p>HIGH PERFORMANCE INSULATED GLAZING</p>	<p><b>STOREFRONT SYSTEM</b></p>  <p>ALUMINUM MULLION</p>  <p>CLEAR GLASS</p>	<p><b>BASE</b></p>  <p>BRICK TILE</p>
---	--	---	--	--	--



# T3 WEST / CHESTER STREET ELEVATION



## 7TH FLOOR

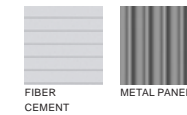
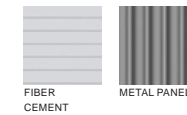
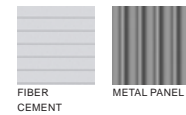
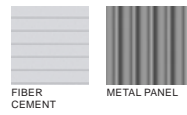
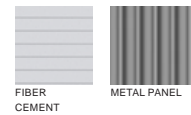

## 2-6TH FLOOR

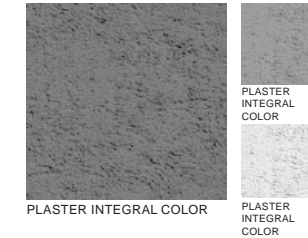
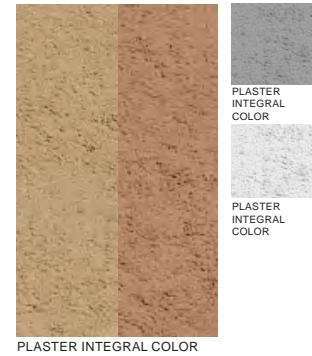
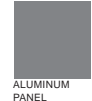
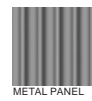

## GROUND FLOOR



## WINDOW SYSTEM

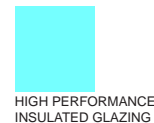

## BALCONY

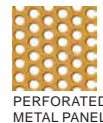
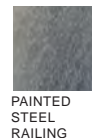

## STOREFRONT SYSTEM



## BASE





HIGH PERFORMANCE ALUMINUM  
WINDOWS - FIXED/OPERABLE

METAL RAILING W/  
PERFORATED METAL PANEL

ALUMINUM WINDOW WALL  
SYSTEM W/ CUSTOM COLOR  
FINISH AND HIGH PERFORMANCE  
INSULATED GLASS

ALUMINUM STORE FRONT  
WINDOW WALL W/ CUSTOM  
COLOR POWDER COAT FINISH

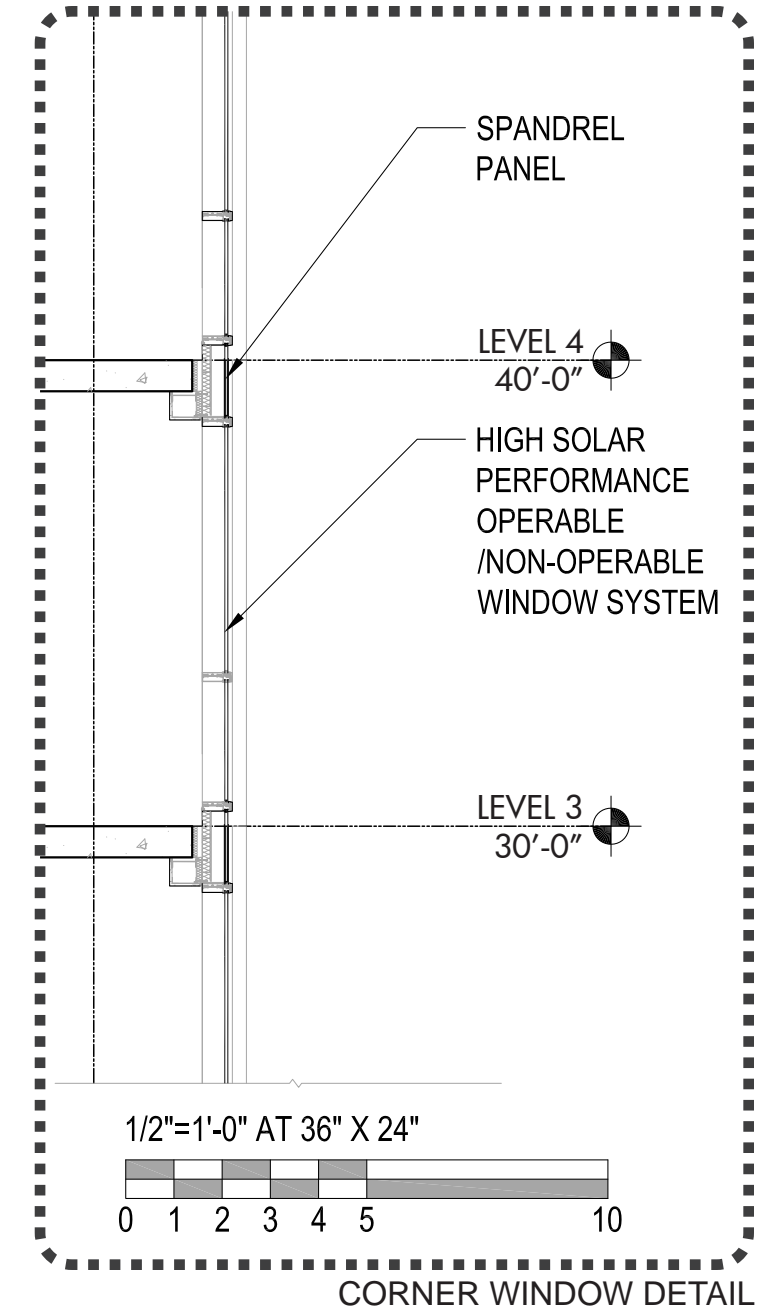

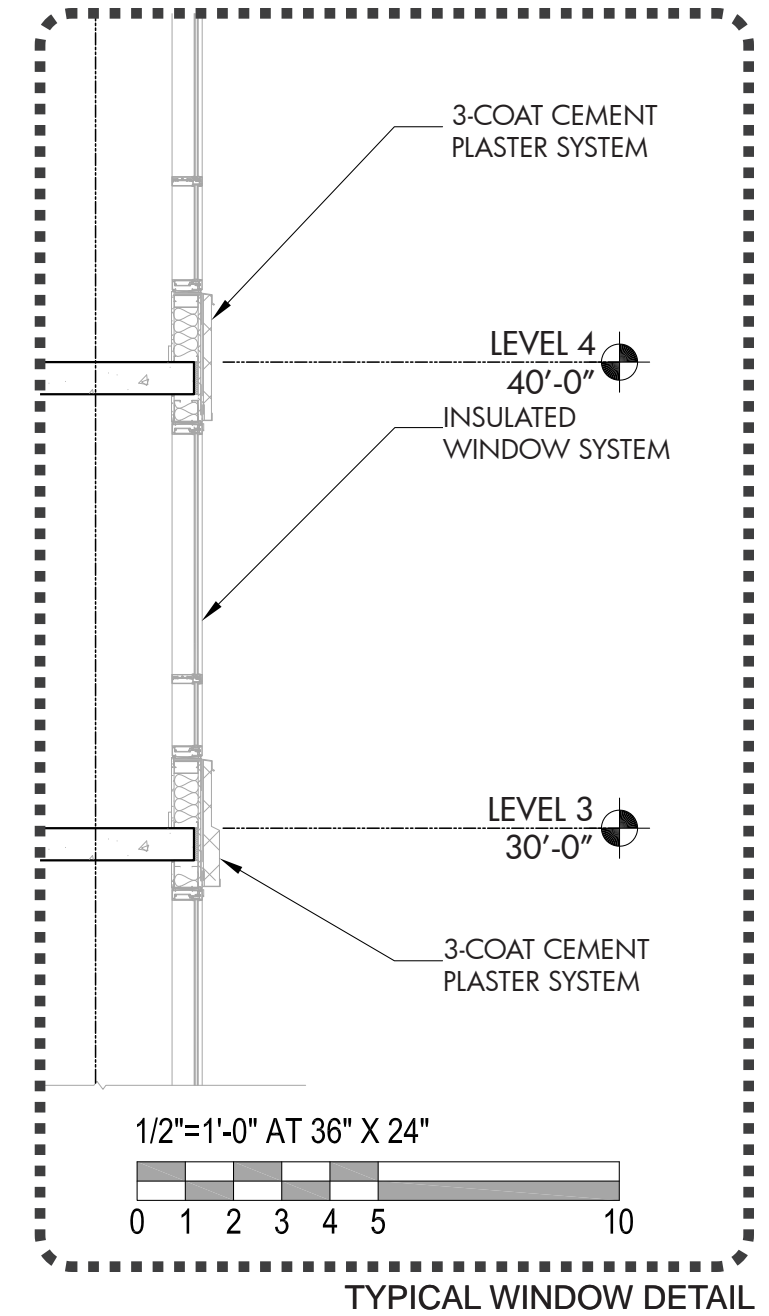
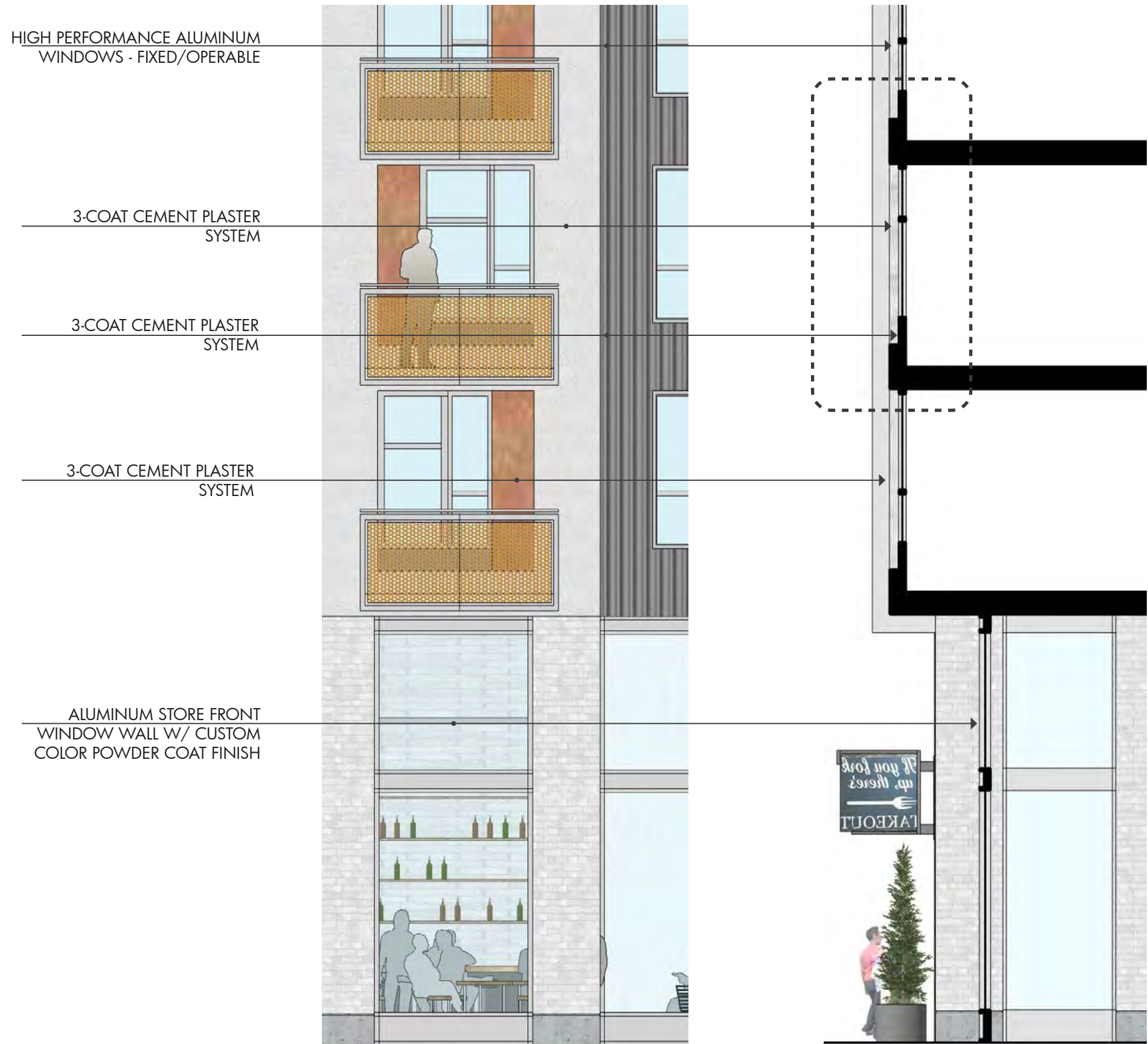

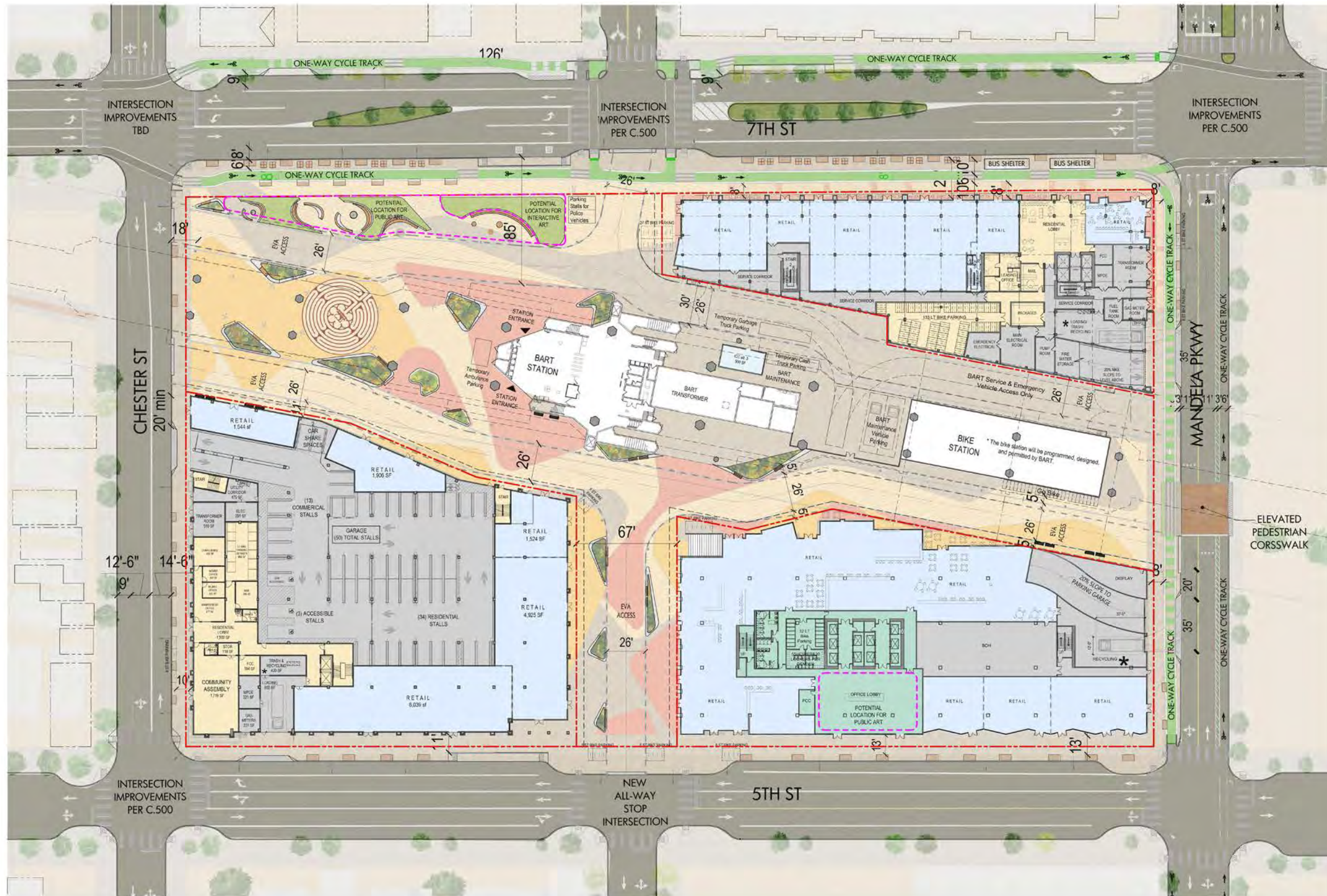

1. The recycling space on T1 site is 1,150 cubic feet minimum, on T3 site is 510 cubic feet minimum, and on T4 site is 647 cubic feet minimum. The total recycling space on site is 2,307 cubic feet minimum.

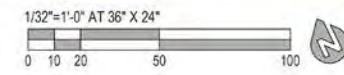

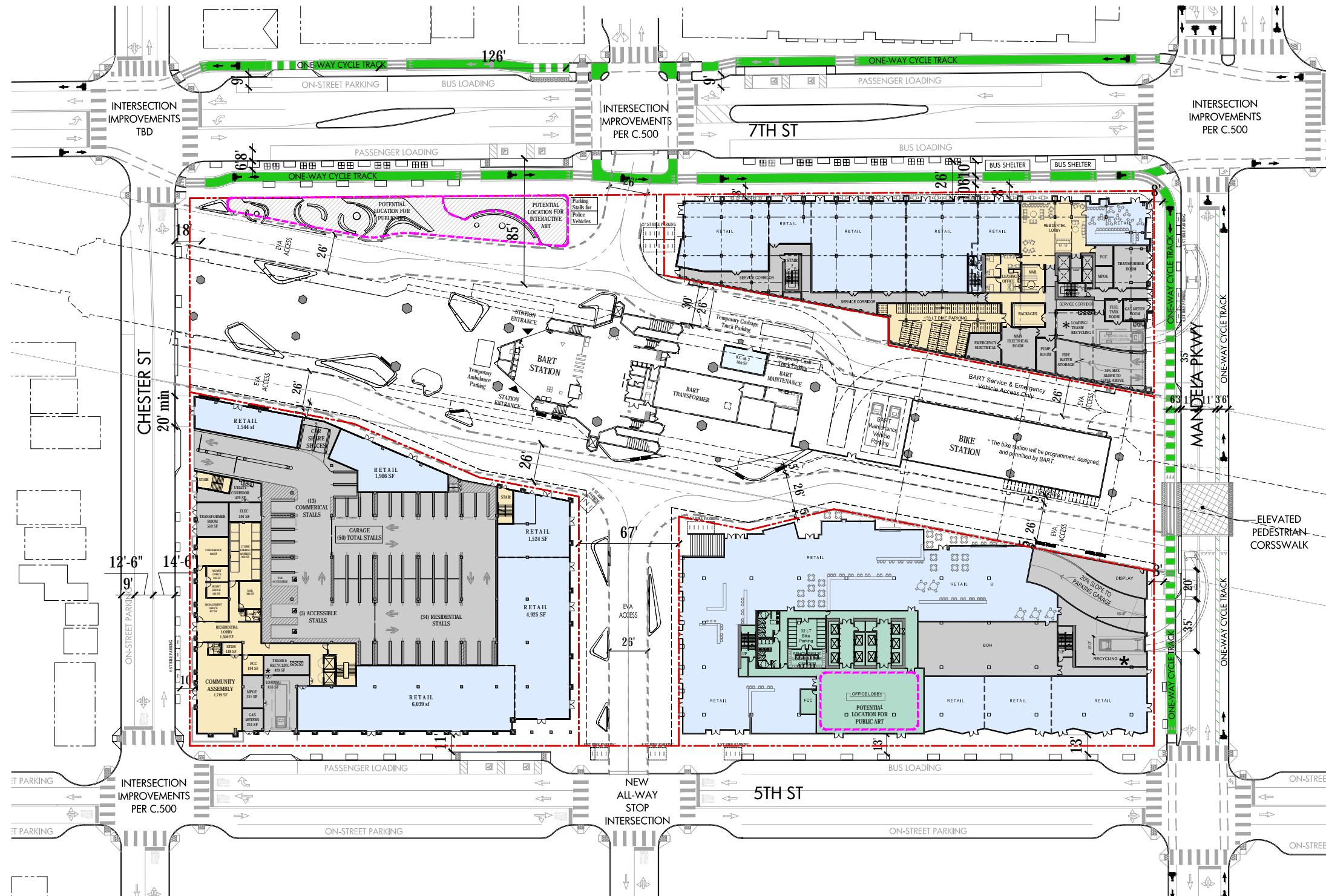

1. The recycling space on T1 site is 1,150 cubic feet minimum, on T3 site is 510 cubic feet minimum, and on T4 site is 647 cubic feet minimum. The total recycling space on site is 2,307 cubic feet minimum.

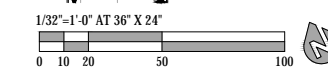

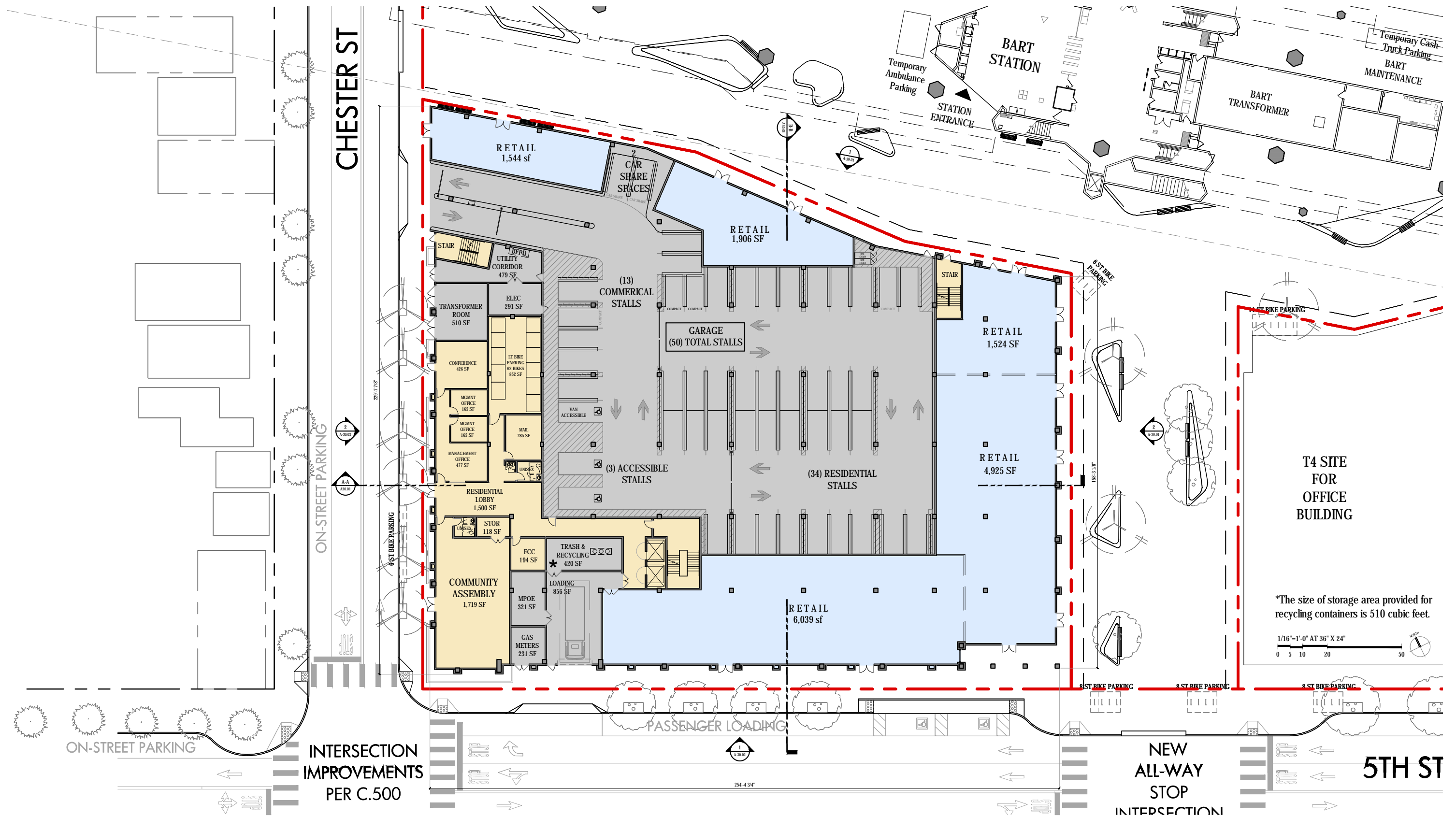



T4 SITE  
FOR  
OFFICE  
BUILDING

1/16"=1'-0" AT 36" X 24"  
0 5 10 20 50



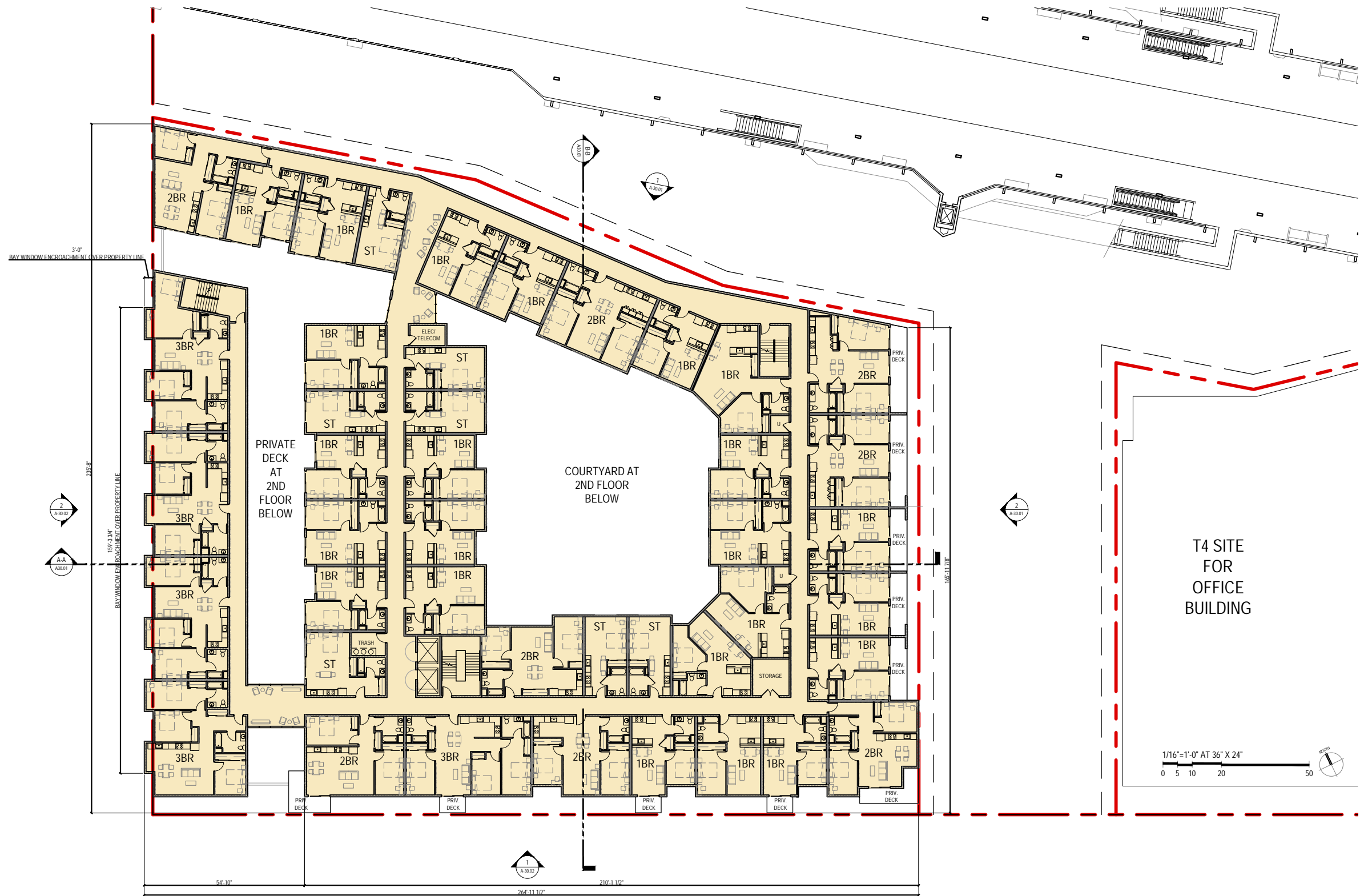

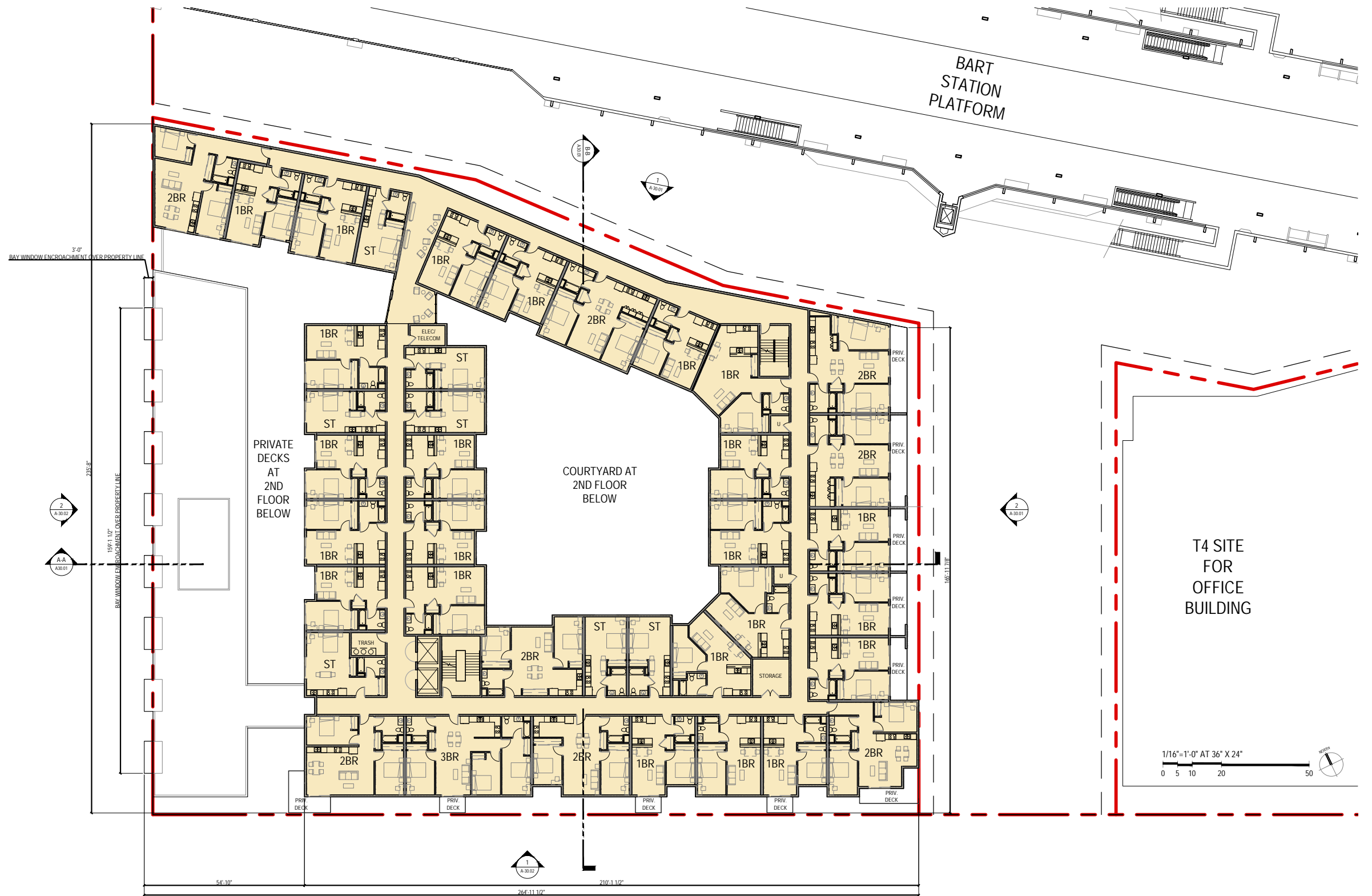

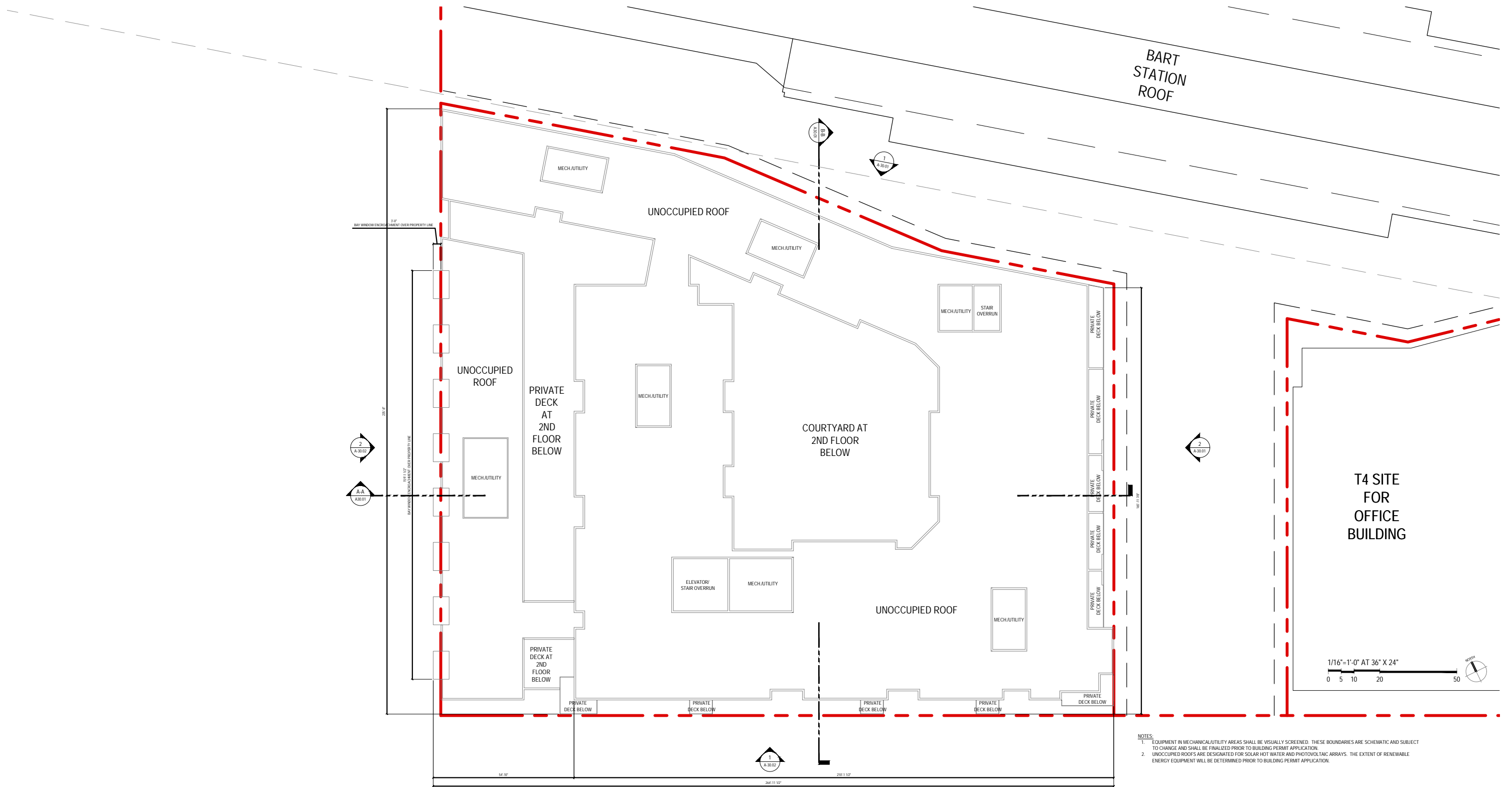

NOTES:  
 1. EQUIPMENT IN MECHANICAL UTILITY AREAS SHALL BE VISUALLY SCREENED. THESE BOUNDARIES ARE SCHEMATIC AND SUBJECT TO CHANGE AND SHALL BE FINALIZED PRIOR TO BUILDING PERMIT APPLICATION.  
 2. UNOCCUPIED ROOFS ARE DESIGNATED FOR SOLAR HOT WATER AND PHOTOVOLTAIC ARRAYS. THE EXTENT OF RENEWABLE ENERGY EQUIPMENT WILL BE DETERMINED PRIOR TO BUILDING PERMIT APPLICATION.



- ### General Elevation Notes
1. Refer to A-53.01, A-53.02 for window detail
  2. Refer to A-02.03 for additional information about material
  3. Refer to Landscape Architect & Civil Drawings for additional information.



- ### General Elevation Notes
1. Refer to A-53.01, A-53.02 for window detail
  2. Refer to A-02.03 for additional information about material
  3. Refer to Landscape Architect & Civil Drawings for additional information.



- ### General Elevation Notes
1. Refer to A-53.01, A-53.02 for window detail
  2. Refer to A-02.03 for additional information about material
  3. Refer to Landscape Architect & Civil Drawings for additional information.



VINYL WALL MOUNTED MURAL

Tiffin Metal Products developed the Wall Mount Bracket System as a cost effective means of attaching vinyl to walls.

## WALL MOUNT BRACKET SYSTEM

This system includes stationary and adjustable wall mount brackets manufactured from 12 gauge galvanized material. The adjustable wall mount brackets include an 8" full thread shoulder bolt to tension the vinyl. To complete the package, 3/4" diameter fiberglass rods are available in 10', 12' and 14' lengths.

Note: Mounting hardware supplied by customer.

**TIFFIN** METAL PRODUCTS

**TIFFIN METAL PRODUCTS CO.™**  
450 Wall Street · Tiffin, Ohio 44883  
800-537-0983 · www.tiffinmetal.com

CONCEALED BRACKET SYSTEM



ACCESS & INSTALLATION SYSTEM

## Public Art References – Art Exhibition Wall

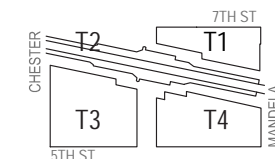



- ### General Elevation Notes
1. Refer to A-53.01, A-53.02 for window detail
  2. Refer to A-02.03 for additional information about material
  3. Refer to Landscape Architect & Civil Drawings for additional information.



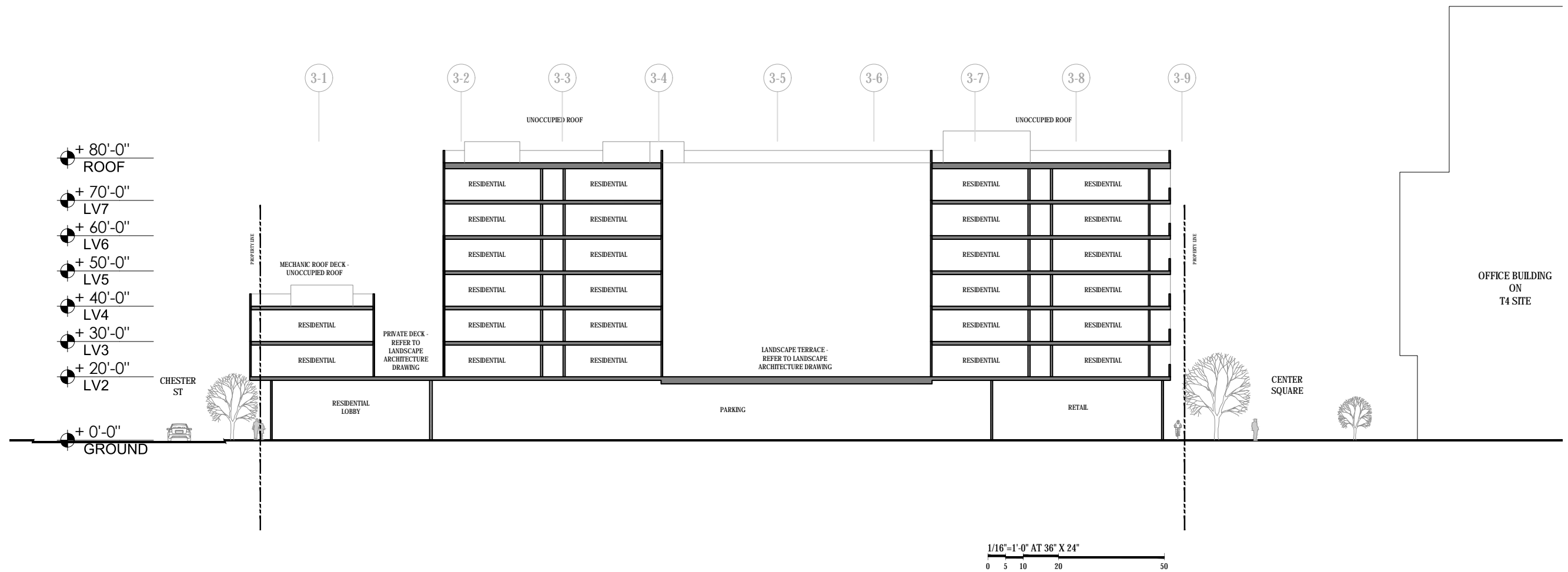

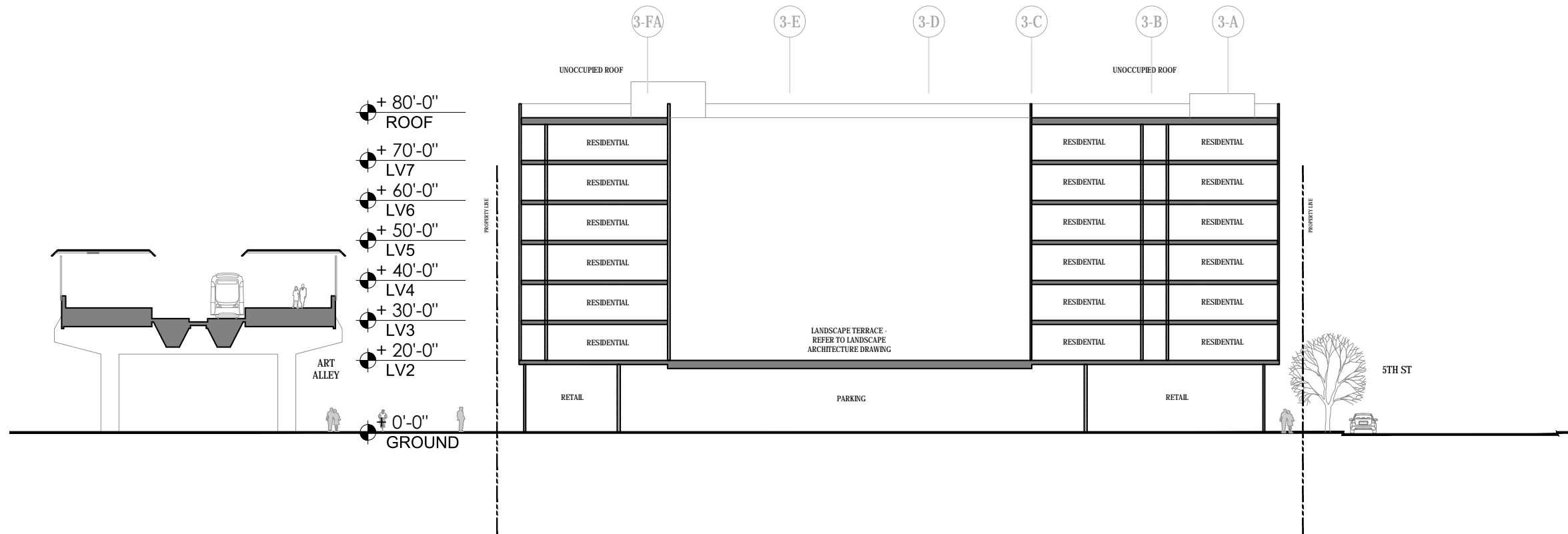

1/16"=1'-0" AT 36" X 24"  
 0 5 10 20 50

## **ATTACHMENT H:**

### **Conditions of Approval:**

1. Standard Conditions of Approval, with proposed revisions
2. Oakland Department of Transportation, Engineering Services Conditions of Approval
3. Oakland Department of Transportation, City Surveyor Conditions of Approval
4. Oakland Fire Department Conditions of Approval

## **Exhibit 1:**

### **Conditions of Approval**

- Standard Conditions of Approval, with proposed revisions

## ATTACHMENT H

### CONDITIONS OF APPROVAL

#### PROJECT: WEST OAKLAND BART TRANSIT-ORIENTED DEVELOPMENT PROJECT SPONSORS: CHINA HARBOR ENGINEERING/ STRATEGIC URBAN DEVELOPMENT ALLIANCE

*As Approved by Planning Commission on February 6, 2019, and amended on  
November 4, 2020 (amendments underlined)*

---

#### **Part 1: Standard Conditions of Approval – General Administrative Conditions**

---

##### **1. Approved Use**

The project shall be constructed and operated in accordance with the authorized use as described in the approved application materials dated February 6, 2019 and the approved plans, as amended by the following conditions of approval and mitigation measures, if applicable (“Conditions of Approval” or “Conditions”).

This action by the Planning Commission includes the approvals set forth below. This Approval includes:

- a. West Oakland BART TOD PUD permit, including West Oakland BART TOD Preliminary Development Plan (February 6, 2019) and West Oakland BART TOD Design Guidelines (February 6, 2019).
- b. Transportation Demand Management (TDM) Plan
- c. Greenhouse Gas Reduction Plan (GGRP)
- d. Vesting Tentative Parcel Map (10940)

##### **2. Effective Date, Expiration, Extensions and Extinguishment**

Pursuant to the City’s Subdivision Code, an approved Vesting Tentative Parcel Map expires two years after its approval, but may be extended for an additional year, for a maximum for a three-year period. The California Subdivision Map Act, however, specifies that an approved tentative map expires two years after its approval and that upon application of the subdivider prior to the expiration of the approved tentative map, the life of the tentative map may be extended for an additional six years. Case law indicates that these provisions in the California Subdivision Map Act preempt the City’s Subdivision Code. This Approval shall become effective immediately, unless the Approval is appealable, in which case the Approval shall become effective in ten (10) calendar days unless an appeal is filed.

Upon written request and payment of appropriate fees submitted no later than the expiration date of this Approval, the Director of City Planning or designee may grant a one-year extension of this date, with additional extensions subject to approval by the approving body. Expiration of any necessary building permit or other construction-related permit for this project may invalidate this

Approval if said Approval has also expired. If litigation is filed challenging this Approval, or its implementation, then the time period stated above for obtaining necessary permits for construction or alteration and/or commencement of authorized activities is automatically extended for the duration of the litigation.

The Preliminary Development Plan Approval shall become effective in ten (10) calendar days unless an appeal is filed. Unless a different termination date is prescribed, this Approval shall expire two years from the Approval date, or from the date of the final decision in the event of an appeal, unless within such period a complete Final Development Plan application has been submitted. A complete Final Development Plan shall be submitted to the Bureau of Planning every two years in order to prevent the Preliminary Development Plan from expiring. The Final Development Plans shall expire two years from approval date, unless within such period a complete building permit application has been filed with the Bureau of Building and is diligently pursued towards completion, or the authorized activities have commenced in the case of a permit not involving construction or alteration. Upon written request and payment of appropriate fees submitted no later than the expiration date of this Approval, the Director of City Planning or designee may grant a one-year extension of this date, with additional extensions subject to approval by the approving body. Expiration of any necessary building permit or other construction-related permit for this project may invalidate this Approval if said Approval has also expired. If litigation is filed challenging this Approval, or its implementation, then the time period stated above for obtaining necessary permits for construction or alteration and/or commencement of authorized activities is automatically extended for the duration of the litigation.

**3. Compliance with Other Requirements**

The project applicant shall comply with all other applicable federal, state, regional, rapid transit districts (such as BART), and local laws/codes, requirements, regulations, and guidelines, including but not limited to those imposed by the City's Planning and Building Department, Fire Marshal, Department of Transportation, and Public Works Department. Compliance with other applicable requirements may require changes to the approved use and/or plans. These changes shall be processed in accordance with the procedures contained in Condition #4.

**4. Minor and Major Changes**

a. Minor changes to the approved project, plans, Conditions, facilities, or use may be approved administratively by the Director of City Planning. Major changes to the approved project, plans, Conditions, facilities, or use shall be reviewed by the Director of City Planning to determine whether such changes require submittal and approval of a revision to the Approval by the original approving body or a new independent permit/approval. Major revisions shall be reviewed in accordance with the procedures required for the original permit/approval. A new independent permit/approval shall be reviewed in accordance with the procedures required for the new permit/approval.

Major changes include, but are not limited to, changes of any of the following: decrease in the amount of affordable housing units, increase in the number of units, substantial change in building footprint, substantial change in height, etc.

**5. Compliance with Conditions of Approval**

- a. The project applicant and property owner, including successors, (collectively referred to hereafter as the “project applicant” or “applicant”) shall be responsible for compliance with all the Conditions of Approval and any recommendations contained in any submitted and approved technical report at his/her sole cost and expense, subject to review and approval by the City of Oakland.
- b. The City of Oakland reserves the right at any time during construction to require certification by a licensed professional at the project applicant’s expense that the as-built project conforms to all applicable requirements, including but not limited to, approved maximum heights and minimum setbacks. Failure to construct the project in accordance with the Approval may result in remedial reconstruction, permit revocation, permit modification, stop work, permit suspension, or other corrective action.
- c. Violation of any term, Condition, or project description relating to the Approval is unlawful, prohibited, and a violation of the Oakland Municipal Code. The City of Oakland reserves the right to initiate civil and/or criminal enforcement and/or abatement proceedings, or after notice and public hearing, to revoke the Approval or alter these Conditions if it is found that there is violation of any of the Conditions or the provisions of the Planning Code or Municipal Code, or the project operates as or causes a public nuisance. This provision is not intended to, nor does it, limit in any manner whatsoever the ability of the City to take appropriate enforcement actions. The project applicant shall be responsible for paying fees in accordance with the City’s Master Fee Schedule for inspections conducted by the City or a City-designated third-party to investigate alleged violations of the Approval or Conditions.

**6. Signed Copy of the Approval/Conditions**

A copy of the Approval letter and Conditions shall be signed by the project applicant, attached to each set of permit plans submitted to the appropriate City agency for the project, and made available for review at the project job site at all times.

**7. Blight/Nuisances**

The project site shall be kept in a blight/nuisance-free condition. Any existing blight or nuisance shall be abated within sixty (60) days of approval, unless an earlier date is specified elsewhere.

**8. Indemnification**

- a. To the maximum extent permitted by law, the project applicant shall defend (with counsel acceptable to the City), indemnify, and hold harmless the City of Oakland, the Oakland City Council, the Oakland Redevelopment Successor Agency, the Oakland City Planning Commission, and their respective agents, officers, employees, and volunteers (hereafter collectively called “City”) from any liability, damages, claim, judgment, loss (direct or indirect), action, causes of action, or proceeding (including legal costs, attorneys’ fees, expert witness or consultant fees, City Attorney or staff time, expenses or costs) (collectively called “Action”) against the City to attack, set aside, void or annul this Approval or implementation of this Approval. The City may elect, in its sole discretion, to participate in the defense of said Action and the project applicant shall reimburse the City for its reasonable legal costs and attorneys’ fees.

- b. Within ten (10) calendar days of the filing of any Action as specified in subsection (a) above, the project applicant shall execute a Joint Defense Letter of Agreement, or similarly termed document, with the City, acceptable to the Office of the City Attorney, which memorializes the above obligations. These obligations and the Joint Defense Letter of Agreement shall survive termination, extinguishment, or invalidation of the Approval. Failure to timely execute the Letter of Agreement does not relieve the project applicant of any of the obligations contained in this Condition or other requirements or Conditions of Approval that may be imposed by the City.

**9. Severability**

The Approval would not have been granted but for the applicability and validity of each and every one of the specified Conditions, and if one or more of such Conditions is found to be invalid by a court of competent jurisdiction this Approval would not have been granted without requiring other valid Conditions consistent with achieving the same purpose and intent of such Approval.

**10. Special Inspector/Inspections, Independent Technical Review, Project Coordination and Monitoring**

The project applicant may be required to cover the full costs of independent third-party technical review and City monitoring and inspection, including without limitation, special inspector(s)/inspection(s) during times of extensive or specialized plan-check review or construction, and inspections of potential violations of the Conditions of Approval. The project applicant shall establish a deposit with Engineering Services and/or the Bureau of Building, if directed by the Director of Public Works, Building Official, Director of City Planning, Director of Transportation, or designee, prior to the issuance of a construction-related permit and on an ongoing as-needed basis.

**11. Public Improvements**

The project applicant shall obtain all necessary permits/approvals, such as encroachment permits, obstruction permits, curb/gutter/sidewalk permits, and public improvement (“p-job”) permits from the City for work in the public right-of-way, including but not limited to, streets, curbs, gutters, sidewalks, utilities, and fire hydrants. Prior to any work in the public right-of-way, the applicant shall submit plans for review and approval by the Bureau of Planning, the Bureau of Building, Engineering Services, Department of Transportation, and other City departments as required. Public improvements shall be designed and installed to the satisfaction of the City.

The public improvements included in the project that shall comply with this condition include, but are not limited to, the following:

Streetscape Improvements

- 7<sup>th</sup> Street Improvements
  - Raised Class IV one-way separated bikeways on both sides of 7<sup>th</sup> Street between Chester St and Mandela Pkwy
  - Minimum 8 ft pedestrian through zone on the sidewalk between Chester St and Mandela Pkwy. 7<sup>th</sup> St sidewalk to provide adequate width to accommodate high level of pedestrians with pedestrian amenities such as seating, real-time bus arrival information, trash receptacles, and pedestrian-lighting



- Approximately 270-foot extended bus stop on eastbound 7<sup>th</sup> St at Mandela Pkwy
- Approximately 130-foot bus stop on westbound 7<sup>th</sup> St just west of Center St
- Approximately 250 feet of linear curb designated for passenger loading and unloading on eastbound 7<sup>th</sup> St between Chester St and Center St, with about 50 feet of curb on eastbound 7<sup>th</sup> St just west of Center St designated as blue accessible loading zone.
- Mandela Parkway Improvements
  - Class IV one-way separated bikeways on both sides of Mandela Pkwy between 7<sup>th</sup> St and 5<sup>th</sup> St
  - Minimum 8 ft pedestrian through zone on the sidewalk between 7<sup>th</sup> St and 5<sup>th</sup> St
  - Prohibit parking on the west side of Mandela Parkway between 5<sup>th</sup> St and 7<sup>th</sup> St
- 5<sup>th</sup> Street Improvements
  - Minimum 8 ft pedestrian through zone on the sidewalk between Chester Street and Mandela Parkway
  - Approximately 170-foot long bus stop and layover zone with a concrete bus pad on 5<sup>th</sup> Street just west of Mandela Pkwy.
  - Approximately 100 feet of linear curb designated for passenger loading and unloading east of Center St and about 200 feet west of Center St
- Chester Street Improvements
  - Minimum 8 ft pedestrian through zone on the sidewalk between 7<sup>th</sup> St and 5<sup>th</sup> St
  - Centerline redesigned to facilitate northbound bus turning movements.
  - Prohibit parking on the east side of Chester St between 5<sup>th</sup> St and 7<sup>th</sup> St and on the west side of Chester St for about 100 feet south of 7<sup>th</sup> St.

Intersection Improvements

- 5<sup>th</sup> St and Center St
  - High-visibility crosswalks and directional ramps
  - Curb extensions
- 5<sup>th</sup> St and Chester St
  - High-visibility crosswalks and directional ramps
- 5<sup>th</sup> St and Mandela Pkwy
  - High-visibility crosswalks and directional ramps
- Mandela Pkwy between 5<sup>th</sup> St and 7<sup>th</sup> St
  - High-visibility, mid-block pedestrian crossing

Other:

- Bike station on the east side of the existing BART station, under the BART tracks, accommodating at least 500 bicycles.

**12. Compliance Matrix**

The project applicant shall submit a Compliance Matrix, in both written and electronic form, for review and approval by the Bureau of Planning and the Bureau of Building that lists each Condition of Approval (including each mitigation measure if applicable) in a sortable spreadsheet. The Compliance Matrix shall contain, at a minimum, each required Condition of Approval, when compliance with the Condition is required, and the status of compliance with each Condition. For multi-phased projects, the Compliance Matrix shall indicate which Condition

applies to each phase. The project applicant shall submit the initial Compliance Matrix prior to the issuance of the first construction-related permit and shall submit an updated matrix upon request by the City.

**13. Construction Management Plan**

Prior to the issuance of the first construction-related permit, the project applicant and his/her general contractor shall submit a Construction Management Plan (CMP) for review and approval by the Bureau of Planning, Bureau of Building, and other relevant City departments such as the Fire Department, Department of Transportation, and the Public Works Department as directed. The CMP shall contain measures to minimize potential construction impacts including measures to comply with all construction-related Conditions of Approval (and mitigation measures if applicable) such as dust control, construction emissions, hazardous materials, construction days/hours, construction traffic control, waste reduction and recycling, stormwater pollution prevention, noise control, complaint management, and cultural resource management (see applicable Conditions below). The CMP shall provide project-specific information including descriptive procedures, approval documentation, and drawings (such as a site logistics plan, fire safety plan, construction phasing plan, proposed truck routes, traffic control plan, complaint management plan, construction worker parking plan, and litter/debris clean-up plan) that specify how potential construction impacts will be minimized and how each construction-related requirement will be satisfied throughout construction of the project.

**14. Standard Conditions of Approval / Mitigation Monitoring and Reporting Program (SCAMMRP)**

a. All mitigation measures identified in the **Addendum #1 to the West Oakland Specific Plan (WOSP) Environmental Impact Report (EIR) (SCH #2012102047)** are included in the Standard Condition of Approval / Mitigation Monitoring and Reporting Program (SCAMMRP) which is included in these Conditions of Approval as Part 2 and are incorporated herein by reference, as Attachment A, as Conditions of Approval of the project. The Standard Conditions of Approval identified in the **Addendum #1 to the WOSP EIR (SCH #2012102047)** are also included in the SCAMMRP, and are, therefore, incorporated into these Conditions by reference but are not repeated in these Conditions. To the extent that there is any inconsistency between the SCAMMRP and these Conditions, the more restrictive Conditions, as determined by the City, shall govern. In the event a Standard Condition of Approval or mitigation measure recommended in the **Addendum #1 to the WOSP EIR (SCH #2012102047)** has been inadvertently omitted from the SCAMMRP, that Standard Condition of Approval or mitigation measure is adopted and incorporated from the **Addendum #1 to the WOSP EIR (SCH #2012102047)** into the SCAMMRP by reference, and adopted as a Condition of Approval. The project applicant and property owner shall be responsible for compliance with the requirements of any submitted and approved technical reports, all applicable mitigation measures adopted, and with all Conditions of Approval set forth herein at his/her sole cost and expense, unless otherwise expressly provided in a specific mitigation measure or Condition of Approval, and subject to the review and approval by the City of Oakland. The SCAMMRP identifies the timeframe and responsible party for implementation and monitoring for each Standard Condition of Approval and mitigation measure. Unless otherwise specified, monitoring of compliance with the Standard Conditions of Approval and mitigation measures will be the responsibility of the Bureau of Planning,

with overall authority concerning compliance residing with the Environmental Review Officer. Adoption of the SCAMMRP will constitute fulfillment of the CEQA monitoring and/or reporting requirement set forth in section 21081.6 of CEQA.

- b. Prior to the issuance of the first construction-related permit, the project applicant shall pay the applicable mitigation and monitoring fee to the City in accordance with the City's Master Fee Schedule.

## Part 2: Standard Conditions of Approval – Environmental Protection Measures

---

### AESTHETICS

#### 15. Trash and Blight Removal

Requirement: The project applicant and his/her successors shall maintain the property free of blight, as defined in chapter 8.24 of the Oakland Municipal Code. For nonresidential and multi-family residential projects, the project applicant shall install and maintain trash receptacles near public entryways as needed to provide sufficient capacity for building users.

When Required: Ongoing

Initial Approval: N/A

Monitoring/Inspection: Bureau of Building

#### 16. Graffiti Control

Requirement:

- a. During construction and operation of the project, the project applicant shall incorporate best management practices reasonably related to the control of graffiti and/or the mitigation of the impacts of graffiti. Such best management practices may include, without limitation:
  - i. Installation and maintenance of landscaping to discourage defacement of and/or protect likely graffiti-attracting surfaces.
  - ii. Installation and maintenance of lighting to protect likely graffiti-attracting surfaces.
  - iii. Use of paint with anti-graffiti coating.
  - iv. Incorporation of architectural or design elements or features to discourage graffiti defacement in accordance with the principles of Crime Prevention Through Environmental Design (CPTED).
  - v. Other practices approved by the City to deter, protect, or reduce the potential for graffiti defacement.
- b. The project applicant shall remove graffiti by appropriate means within seventy-two (72) hours. Appropriate means include the following:
  - i. Removal through scrubbing, washing, sanding, and/or scraping (or similar method) without damaging the surface and without discharging wash water or cleaning detergents into the City storm drain system.
  - ii. Covering with new paint to match the color of the surrounding surface.
  - iii. Replacing with new surfacing (with City permits if required).

When Required: Ongoing

Initial Approval: N/A

Monitoring/Inspection: Bureau of Building

**17. Landscape Plan**

***a. Landscape Plan Required***

- Requirement: The project applicant shall submit a final Landscape Plan for City review and approval that is consistent with the approved Landscape Plan. The Landscape Plan shall be included with the set of drawings submitted for the construction-related permit and shall comply with the landscape requirements of chapter 17.124 of the Planning Code. Proposed plants shall be predominantly drought-tolerant. Specification of any street trees shall comply with the Master Street Tree List and Tree Planting Guidelines (which can be viewed at <http://www2.oaklandnet.com/oakca1/groups/pwa/documents/report/oak042662.pdf> and <http://www2.oaklandnet.com/oakca1/groups/pwa/documents/form/oak025595.pdf>, respectively), and with any applicable streetscape plan.

When Required: Prior to approval of construction-related permit

Initial Approval: Bureau of Planning

Monitoring/Inspection: N/A

***b. Landscape Installation***

Requirement: The project applicant shall implement the approved Landscape Plan unless a bond, cash deposit, letter of credit, or other equivalent instrument acceptable to the Director of City Planning, is provided. The financial instrument shall equal the greater of \$2,500 or the estimated cost of implementing the Landscape Plan based on a licensed contractor's bid.

When Required: Prior to building permit final

Initial Approval: Bureau of Planning

Monitoring/Inspection: Bureau of Building

***c. Landscape Maintenance***

Requirement: All required planting shall be permanently maintained in good growing condition and, whenever necessary, replaced with new plant materials to ensure continued compliance with applicable landscaping requirements. The property owner shall be responsible for maintaining planting in adjacent public rights-of-way. All required fences, walls, and irrigation systems shall be permanently maintained in good condition and, whenever necessary, repaired or replaced.

When Required: Ongoing

Initial Approval: N/A

Monitoring/Inspection: Bureau of Building

**18. Lighting**

Requirement: Proposed new exterior lighting fixtures shall be adequately shielded to a point below the light bulb and reflector to prevent unnecessary glare onto adjacent properties.

When Required: Prior to building permit final

Initial Approval: N/A

Monitoring/Inspection: Bureau of Building

**19. Public Art for Private Development**

Requirement: The project is subject to the City’s Public Art Requirements for Private Development, adopted by Ordinance No. 13275 C.M.S. (“Ordinance”). The public art contribution requirements are equivalent to one-half percent (0.5%) for the “residential” building development costs, and one percent (1.0%) for the “non-residential” building development costs.

The contribution requirement can be met through: 1) the installation of freely accessible art at the site; 2) the installation of freely accessible art within one-quarter mile of the site; or 3) satisfaction of alternative compliance methods described in the Ordinance, including, but not limited to, payment of an in-lieu fee contribution. The applicant shall provide proof of full payment of the in-lieu contribution and/or provide plans, for review and approval by the Planning Director, showing the installation or improvements required by the Ordinance prior to issuance of a building permit.

Proof of installation of artwork, or other alternative requirement, is required prior to the City’s issuance of a final certificate of occupancy for each phase of a project unless a separate, legal binding instrument is executed ensuring compliance within a timely manner subject to City approval.

When Required: Payment of in-lieu fees and/or plans showing fulfillment of public art requirement – Prior to Issuance of Building permit

Installation of art/cultural space – Prior to Issuance of a Certificate of Occupancy.

Initial Approval: Bureau of Planning

Monitoring/Inspection: Bureau of Building

## **AIR QUALITY**

**20. West Oakland Community Emissions Reduction Program**

Requirement: Project shall comply with all air quality-related standard conditions the City adopts in support of the West Oakland Community Emissions Reduction Program (AB617).

When Required: After adoption of the West Oakland Community Emissions Reduction Program, according to requirements therein

Initial Approval: TBD

Monitoring/Inspection: According to the West Oakland Community Emissions Reduction Program

**21. Dust Controls – Construction Related**

Requirement: The project applicant shall implement all of the following applicable dust control measures during construction of the project:

- a) Water all exposed surfaces of active construction areas at least twice daily. Watering should be sufficient to prevent airborne dust from leaving the site. Increased watering frequency may be necessary whenever wind speeds exceed 15 miles per hour. Reclaimed water should be used whenever feasible.
- b) Cover all trucks hauling soil, sand, and other loose materials or require all trucks to maintain at least two feet of freeboard (i.e., the minimum required space between the top of the load and the top of the trailer).
- c) All visible mud or dirt track-out onto adjacent public roads shall be removed using wet power vacuum street sweepers at least once per day. The use of dry power sweeping is prohibited.
- d) Limit vehicle speeds on unpaved roads to 15 miles per hour.
- e) All demolition activities (if any) shall be suspended when average wind speeds exceed 20 mph.
- f) All trucks and equipment, including tires, shall be washed off prior to leaving the site.
- g) Site accesses to a distance of 100 feet from the paved road shall be treated with a 6 to 12 inch compacted layer of wood chips, mulch, or gravel.

When Required: During construction

Initial Approval: N/A

Monitoring/Inspection: Bureau of Building

**22. Criteria Air Pollutant Controls - Construction Related**

Requirement: The project applicant shall implement all of the following applicable basic control measures for criteria air pollutants during construction of the project as applicable:

- a) Idling times on all diesel-fueled commercial vehicles over 10,000 lbs. shall be minimized either by shutting equipment off when not in use or reducing the maximum idling time to two minutes (as required by the California airborne toxics control measure Title 13, Section 2485, of the California Code of Regulations). Clear signage to this effect shall be provided for construction workers at all access points.
- b) Idling times on all diesel-fueled off-road vehicles over 25 horsepower shall be minimized either by shutting equipment off when not in use or reducing the maximum idling time to two minutes and fleet operators must develop a written policy as required by Title 23, Section 2449, of the California Code of Regulations (“California Air Resources Board Off-Road Diesel Regulations”).
- c) All construction equipment shall be maintained and properly tuned in accordance with the manufacturer’s specifications. All equipment shall be checked by a certified mechanic and determined to be running in proper condition prior to operation. Equipment check documentation should be kept at the construction site and be available for review by the City and the Bay Area Air Quality District as needed.
- d) Portable equipment shall be powered by grid electricity if available. If electricity is not available, propane or natural gas generators shall be used if feasible. Diesel engines shall

only be used if grid electricity is not available and propane or natural gas generators cannot meet the electrical demand.

- e) Low VOC (i.e., ROG) coatings shall be used that comply with BAAQMD Regulation 8, Rule 3: Architectural Coatings.
- f) All equipment to be used on the construction site shall comply with the requirements of Title 13, Section 2449, of the California Code of Regulations (“California Air Resources Board Off-Road Diesel Regulations”) and upon request by the City (and the Air District if specifically requested), the project applicant shall provide written documentation that fleet requirements have been met.

When Required: During construction

Initial Approval: N/A

Monitoring/Inspection: Bureau of Building

**Construction activities with average daily emissions exceeding the CEQA thresholds for construction activity, currently 54 pounds per day of ROG, NOx, or PM2.5 or 82 pounds per day of PM10. In most cases, criteria pollutants from construction will not require SCA measures, but analysis must be performed to determine applicability for projects that exceed 100,000 square feet of non-residential development or 200 residential dwelling units.**

- g) Criteria Air Pollutant Reduction Measures

Requirement: The project applicant shall retain a qualified air quality consultant to identify criteria air pollutant reduction measures to reduce the project's average daily emissions below 54 pounds per day of ROG, NOx, or PM2.5 or 82 pounds per day of PM10. Quantified emissions and identified reduction measures shall be submitted to the City (and the Air District if specifically requested) for review and approval prior to the issuance of building permits and the approved criteria air pollutant reduction measures shall be implemented during construction.

- h) Construction Emissions Minimization Plan

Requirement: The project applicant shall prepare a Construction Emissions Minimization Plan (Emissions Plan) for all identified criteria air pollutant reduction measures. The Emissions Plan shall be submitted to the City (and the Air District if specifically requested) for review and approval prior to the issuance of building permits. The Emissions Plan shall include the following:

- i. An equipment inventory summarizing the type of off-road equipment required for each phase of construction, including the equipment manufacturer, equipment identification number, engine model year, engine certification (tier rating), horsepower, and engine serial number. For all Verified Diesel Emissions Control Strategies (VDECS), the equipment inventory shall also include the technology type, serial number, make, model, manufacturer, CARB verification number level, and installation date.



- ii. A Certification Statement that the Contractor agrees to comply fully with the Emissions Plan and acknowledges that a significant violation of the Emissions Plan shall constitute a material breach of contract.

When Required: Prior to issuance of a construction related permit

Initial Approval: Bureau of Planning

Monitoring/Inspection: Bureau of Building

**23. Diesel Particulate Matter Controls-Construction Related**

***a. Diesel Particulate Matter Reduction Measures***

Requirement: The project applicant shall implement appropriate measures during construction to reduce potential health risks to sensitive receptors due to exposure to diesel particulate matter (DPM) from construction emissions. The project applicant shall choose **one** of the following methods:

- i. The project applicant shall retain a qualified air quality consultant to prepare a Health Risk Assessment (HRA) in accordance with current guidance from the California Air Resources Board (CARB) and Office of Environmental Health and Hazard Assessment to determine the health risk to sensitive receptors exposed to DPM from project construction emissions. The HRA shall be submitted to the City (and the Air District if specifically requested) for review and approval. If the HRA concludes that the health risk is at or below acceptable levels, then DPM reduction measures are not required. If the HRA concludes that the health risk exceeds acceptable levels, DPM reduction measures shall be identified to reduce the health risk to acceptable levels as set forth under subsection b below. Identified DPM reduction measures shall be submitted to the City for review and approval prior to the issuance of building permits and the approved DPM reduction measures shall be implemented during construction.

-or-

- ii. All off-road diesel equipment shall be equipped with the most effective Verified Diesel Emission Control Strategies (VDECS) available for the engine type (Tier 4 engines automatically meet this requirement) as certified by CARB. The equipment shall be properly maintained and tuned in accordance with manufacturer specifications. This shall be verified through an equipment inventory submittal and Certification Statement that the Contractor agrees to compliance and acknowledges that a significant violation of this requirement shall constitute a material breach of contract.

When Required: Prior to issuance of a construction related permit (i), during construction (ii)

Initial Approval: Bureau of Planning

Monitoring/Inspection: Bureau of Building

***b. Construction Emissions Minimization Plan (if required by a above)***

Requirement: The project applicant shall prepare a Construction Emissions Minimization Plan (Emissions Plan) for all identified DPM reduction measures (if any). The Emissions Plan shall be submitted to the City (and the Bay Area Air Quality District if specifically requested) for

review and approval prior to the issuance of building permits. The Emissions Plan shall include the following:

- i. An equipment inventory summarizing the type of off-road equipment required for each phase of construction, including the equipment manufacturer, equipment identification number, engine model year, engine certification (tier rating), horsepower, and engine serial number. For all VDECS, the equipment inventory shall also include the technology type, serial number, make, model, manufacturer, CARB verification number level, and installation date.
- ii. A Certification Statement that the Contractor agrees to comply fully with the Emissions Plan and acknowledges that a significant violation of the Emissions Plan shall constitute a material breach of contract.

When Required: Prior to issuance of a construction related permit

Initial Approval: Bureau of Planning

Monitoring/Inspection: Bureau of Building

**24. Exposure to Air Pollution (Toxic Air Contaminants)**

***a. Health Risk Reduction Measures***

Requirement: The project applicant shall incorporate appropriate measures into the project design in order to reduce the potential health risk due to exposure to toxic air contaminants. The project applicant shall choose **one** of the following methods:

- i. The project applicant shall retain a qualified air quality consultant to prepare a Health Risk Assessment (HRA) in accordance with California Air Resources Board (CARB) and Office of Environmental Health and Hazard Assessment requirements to determine the health risk of exposure of project residents/occupants/users to air pollutants. The HRA shall be submitted to the City for review and approval. If the HRA concludes that the health risk is at or below acceptable levels, then health risk reduction measures are not required. If the HRA concludes that the health risk exceeds acceptable levels, health risk reduction measures shall be identified to reduce the health risk to acceptable levels. Identified risk reduction measures shall be submitted to the City for review and approval and be included on the project drawings submitted for the construction-related permit or on other documentation submitted to the City.

- or -

- ii. The project applicant shall incorporate the following health risk reduction measures into the project. These features shall be submitted to the City for review and approval and be included on the project drawings submitted for the construction-related permit or on other documentation submitted to the City:
  - Installation of air filtration to reduce cancer risks and Particulate Matter (PM) exposure for residents and other sensitive populations in the project that are in close proximity to sources of air pollution. Air filter devices shall be rated MERV-16 or higher. As part of implementing this measure, an ongoing maintenance plan for the building’s HVAC air filtration system shall be required.
  - Where appropriate, install passive electrostatic filtering systems, especially those with low air velocities (i.e., 1 mph).

- Phasing of residential developments when proposed within 500 feet of freeways such that homes nearest the freeway are built last, if feasible.
- The project shall be designed to locate sensitive receptors as far away as feasible from the source(s) of air pollution. Operable windows, balconies, and building air intakes shall be located as far away from these sources as feasible. If near a distribution center, residents shall be located as far away as feasible from a loading dock or where trucks concentrate to deliver goods.
- Sensitive receptors shall be located on the upper floors of buildings, if feasible.
- Planting trees and/or vegetation between sensitive receptors and pollution source, if feasible. Trees that are best suited to trapping PM shall be planted, including one or more of the following: Pine (*Pinus nigra* var. *maritima*), Cypress (*X Cupressocyparis leylandii*), Hybrid poplar (*Populus deltoids X trichocarpa*), and Redwood (*Sequoia sempervirens*).
- Sensitive receptors shall be located as far away from truck activity areas, such as loading docks and delivery areas, as feasible.
- Existing and new diesel generators shall meet CARB's Tier 4 emission standards, if feasible.
- Emissions from diesel trucks shall be reduced through implementing the following measures, if feasible:
  - Installing electrical hook-ups for diesel trucks at loading docks.
  - Requiring trucks to use Transportation Refrigeration Units (TRU) that meet Tier 4 emission standards.
  - Requiring truck-intensive projects to use advanced exhaust technology (e.g., hybrid) or alternative fuels.
  - Prohibiting trucks from idling for more than two minutes.
  - Establishing truck routes to avoid sensitive receptors in the project. A truck route program, along with truck calming, parking, and delivery restrictions, shall be implemented.

When Required: Prior to approval of construction-related permit

Initial Approval: Bureau of Planning

Monitoring/Inspection: Bureau of Building

***b. Maintenance of Health Risk Reduction Measures***

Requirement: The project applicant shall maintain, repair, and/or replace installed health risk reduction measures, including but not limited to the HVAC system (if applicable), on an ongoing and as-needed basis. Prior to occupancy, the project applicant shall prepare and then distribute to the building manager/operator an operation and maintenance manual for the HVAC system and filter including the maintenance and replacement schedule for the filter.

When Required: Ongoing

Initial Approval: N/A

Monitoring/Inspection: Bureau of Building

**25. Stationary Sources of Air Pollution (Toxic Air Contaminants)**

Requirement: The project applicant shall incorporate appropriate measures into the project design in order to reduce the potential health risk due to on-site stationary sources of toxic air contaminants. The project applicant shall choose **one** of the following methods:

- a. The project applicant shall retain a qualified air quality consultant to prepare a Health Risk Assessment (HRA) in accordance with California Air Resources Board (CARB) and Office of Environmental Health and Hazard Assessment requirements to determine the health risk associated with proposed stationary sources of pollution in the project. The HRA shall be submitted to the City for review and approval. If the HRA concludes that the health risk is at or below acceptable levels, then health risk reduction measures are not required. If the HRA concludes the health risk exceeds acceptable levels, health risk reduction measures shall be identified to reduce the health risk to acceptable levels. Identified risk reduction measures shall be submitted to the City for review and approval and be included on the project drawings submitted for the construction-related permit or on other documentation submitted to the City.

- or -

- b. The project applicant shall incorporate the following health risk reduction measures into the project. These features shall be submitted to the City for review and approval and be included on the project drawings submitted for the construction-related permit or on other documentation submitted to the City:
  - i. Installation of non-diesel fueled generators, if feasible, or;
  - ii. Installation of diesel generators with an EPA-certified Tier 4 engine or engines that are retrofitted with a CARB Level 3 Verified Diesel Emissions Control Strategy, if feasible.

When Required: Prior to approval of construction-related permit

Initial Approval: Bureau of Planning

Monitoring/Inspection: Bureau of Building

## **BIOLOGICAL RESOURCES**

### **26. Tree Removal During Bird Breeding Season**

Requirement: To the extent feasible, removal of any tree and/or other vegetation suitable for nesting of birds shall not occur during the bird breeding season of February 1 to August 15 (or during December 15 to August 15 for trees located in or near marsh, wetland, or aquatic habitats). If tree removal must occur during the bird breeding season, all trees to be removed shall be surveyed by a qualified biologist to verify the presence or absence of nesting raptors or other birds. Pre-removal surveys shall be conducted within 15 days prior to the start of work and shall be submitted to the City for review and approval. If the survey indicates the potential presence of nesting raptors or other birds, the biologist shall determine an appropriately sized buffer around the nest in which no work will be allowed until the young have successfully fledged. The size of the nest buffer will be determined by the biologist in consultation with the California Department of Fish and Wildlife, and will be based to a large extent on the nesting species and its sensitivity to disturbance. In general, buffer sizes of 200 feet for raptors and 50 feet for other birds should suffice to prevent disturbance to birds nesting in the urban environment, but these buffers may be

increased or decreased, as appropriate, depending on the bird species and the level of disturbance anticipated near the nest.

When Required: Prior to removal of trees

Initial Approval: Bureau of Planning

Monitoring/Inspection: Bureau of Building

**27. Tree Permit**

**a. *Tree Permit Required***

Requirement: Pursuant to the City's Tree Protection Ordinance (OMC chapter 12.36), the project applicant shall obtain a tree permit and abide by the conditions of that permit.

When Required: Prior to approval of construction-related permit

Initial Approval: Permit approval by Public Works Department, Tree Division; evidence of approval submitted to Bureau of Building

Monitoring/Inspection: Bureau of Building

**b. *Tree Protection During Construction***

Requirement: Adequate protection shall be provided during the construction period for any trees which are to remain standing, including the following, plus any recommendations of an arborist:

- i. Before the start of any clearing, excavation, construction, or other work on the site, every protected tree deemed to be potentially endangered by said site work shall be securely fenced off at a distance from the base of the tree to be determined by the project's consulting arborist. Such fences shall remain in place for duration of all such work. All trees to be removed shall be clearly marked. A scheme shall be established for the removal and disposal of logs, brush, earth and other debris which will avoid injury to any protected tree.
- ii. Where proposed development or other site work is to encroach upon the protected perimeter of any protected tree, special measures shall be incorporated to allow the roots to breathe and obtain water and nutrients. Any excavation, cutting, filling, or compaction of the existing ground surface within the protected perimeter shall be minimized. No change in existing ground level shall occur within a distance to be determined by the project's consulting arborist from the base of any protected tree at any time. No burning or use of equipment with an open flame shall occur near or within the protected perimeter of any protected tree.
- iii. No storage or dumping of oil, gas, chemicals, or other substances that may be harmful to trees shall occur within the distance to be determined by the project's consulting arborist from the base of any protected trees, or any other location on the site from which such substances might enter the protected perimeter. No heavy construction equipment or construction materials shall be operated or stored within a distance from the base of any protected trees to be determined by the project's consulting arborist. Wires, ropes, or other devices shall not be attached to any protected tree, except as needed for support of the tree. No sign, other than a tag showing the botanical classification, shall be attached to any protected tree.

- iv. Periodically during construction, the leaves of protected trees shall be thoroughly sprayed with water to prevent buildup of dust and other pollution that would inhibit leaf transpiration.
- v. If any damage to a protected tree should occur during or as a result of work on the site, the project applicant shall immediately notify the Public Works Department and the project's consulting arborist shall make a recommendation to the City Tree Reviewer as to whether the damaged tree can be preserved. If, in the professional opinion of the Tree Reviewer, such tree cannot be preserved in a healthy state, the Tree Reviewer shall require replacement of any tree removed with another tree or trees on the same site deemed adequate by the Tree Reviewer to compensate for the loss of the tree that is removed.
- vi. All debris created as a result of any tree removal work shall be removed by the project applicant from the property within two weeks of debris creation, and such debris shall be properly disposed of by the project applicant in accordance with all applicable laws, ordinances, and regulations.

When Required: During construction

Initial Approval: Public Works Department, Tree Division

Monitoring/Inspection: Bureau of Building

***c. Tree Replacement Plantings***

Requirement: Replacement plantings shall be required for tree removals for the purposes of erosion control, groundwater replenishment, visual screening, wildlife habitat, and preventing excessive loss of shade, in accordance with the following criteria:

- i. No tree replacement shall be required for the removal of nonnative species, for the removal of trees which is required for the benefit of remaining trees, or where insufficient planting area exists for a mature tree of the species being considered.
- ii. Replacement tree species shall consist of *Sequoia sempervirens* (Coast Redwood), *Quercus agrifolia* (Coast Live Oak), *Arbutus menziesii* (Madrone), *Aesculus californica* (California Buckeye), *Umbellularia californica* (California Bay Laurel), or other tree species acceptable to the Tree Division.
- iii. Replacement trees shall be at least twenty-four (24) inch box size, unless a smaller size is recommended by the arborist, except that three fifteen (15) gallon size trees may be substituted for each twenty-four (24) inch box size tree where appropriate.
- iv. Minimum planting areas must be available on site as follows:
  - For *Sequoia sempervirens*, three hundred fifteen (315) square feet per tree;
  - For other species listed, seven hundred (700) square feet per tree.
- v. In the event that replacement trees are required but cannot be planted due to site constraints, an in lieu fee in accordance with the City's Master Fee Schedule may be substituted for required replacement plantings, with all such revenues applied toward tree planting in city parks, streets and medians.
- vi. The project applicant shall install the plantings and maintain the plantings until established. The Tree Reviewer of the Tree Division of the Public Works Department may require a landscape plan showing the replacement plantings and the method of

irrigation. Any replacement plantings which fail to become established within one year of planting shall be replanted at the project applicant's expense.

When Required: Prior to building permit final

Initial Approval: Public Works Department, Tree Division

Monitoring/Inspection: Bureau of Building

## **CULTURAL RESOURCES**

### **28. Archaeological and Paleontological Resources – Discovery During Construction**

Requirement: Pursuant to CEQA Guidelines section 15064.5(f), in the event that any historic or prehistoric subsurface cultural resources are discovered during ground disturbing activities, all work within 50 feet of the resources shall be halted and the project applicant shall notify the City and consult with a qualified archaeologist or paleontologist, as applicable, to assess the significance of the find. In the case of discovery of paleontological resources, the assessment shall be done in accordance with the Society of Vertebrate Paleontology standards. If any find is determined to be significant, appropriate avoidance measures recommended by the consultant and approved by the City must be followed unless avoidance is determined unnecessary or infeasible by the City. Feasibility of avoidance shall be determined with consideration of factors such as the nature of the find, project design, costs, and other considerations. If avoidance is unnecessary or infeasible, other appropriate measures (e.g., data recovery, excavation) shall be instituted. Work may proceed on other parts of the project site while measures for the cultural resources are implemented.

In the event of data recovery of archaeological resources, the project applicant shall submit an Archaeological Research Design and Treatment Plan (ARDTP) prepared by a qualified archaeologist for review and approval by the City. The ARDTP is required to identify how the proposed data recovery program would preserve the significant information the archaeological resource is expected to contain. The ARDTP shall identify the scientific/historic research questions applicable to the expected resource, the data classes the resource is expected to possess, and how the expected data classes would address the applicable research questions. The ARDTP shall include the analysis and specify the curation and storage methods. Data recovery, in general, shall be limited to the portions of the archaeological resource that could be impacted by the proposed project. Destructive data recovery methods shall not be applied to portions of the archaeological resources if nondestructive methods are practicable. Because the intent of the ARDTP is to save as much of the archaeological resource as possible, including moving the resource, if feasible, preparation and implementation of the ARDTP would reduce the potential adverse impact to less than significant. The project applicant shall implement the ARDTP at his/her expense.

In the event of excavation of paleontological resources, the project applicant shall submit an excavation plan prepared by a qualified paleontologist to the City for review and approval. All significant cultural materials recovered shall be subject to scientific analysis, professional museum curation, and/or a report prepared by a qualified paleontologist, as appropriate, according to current professional standards and at the expense of the project applicant.

When Required: During construction

Initial Approval: N/A

Monitoring/Inspection: Bureau of Building

**29. Archaeologically Sensitive Areas – Pre-Construction Measures**

Requirement: The project applicant shall implement either Provision A (Intensive Pre-Construction Study) or Provision B (Construction ALERT Sheet) concerning archaeological resources.

**Provision A: Intensive Pre-Construction Study.**

The project applicant shall retain a qualified archaeologist to conduct a site-specific, intensive archaeological resources study for review and approval by the City prior to soil-disturbing activities occurring on the project site. The purpose of the site-specific, intensive archaeological resources study is to identify early the potential presence of history-period archaeological resources on the project site. At a minimum, the study shall include:

- a. Subsurface presence/absence studies of the project site. Field studies may include, but are not limited to, auguring and other common methods used to identify the presence of archaeological resources.
- b. A report disseminating the results of this research.
- c. Recommendations for any additional measures that could be necessary to mitigate any adverse impacts to recorded and/or inadvertently discovered cultural resources.

If the results of the study indicate a high potential presence of historic-period archaeological resources on the project site, or a potential resource is discovered, the project applicant shall hire a qualified archaeologist to monitor any ground disturbing activities on the project site during construction and prepare an ALERT sheet pursuant to Provision B below that details what could potentially be found at the project site. Archaeological monitoring would include briefing construction personnel about the type of artifacts that may be present (as referenced in the ALERT sheet, required per Provision B below) and the procedures to follow if any artifacts are encountered, field recording and sampling in accordance with the Secretary of Interior’s Standards and Guidelines for Archaeological Documentation, notifying the appropriate officials if human remains or cultural resources are discovered, and preparing a report to document negative findings after construction is completed if no archaeological resources are discovered during construction.

**Provision B: Construction ALERT Sheet.**

The project applicant shall prepare a construction “ALERT” sheet developed by a qualified archaeologist for review and approval by the City prior to soil-disturbing activities occurring on the project site. The ALERT sheet shall contain, at a minimum, visuals that depict each type of artifact that could be encountered on the project site. Training by the qualified archaeologist shall be provided to the project’s prime contractor, any project subcontractor firms (including demolition, excavation, grading, foundation, and pile driving), and utility firms involved in soil-disturbing activities within the project site.

The ALERT sheet shall state, in addition to the basic archaeological resource protection measures contained in other standard conditions of approval, all work must stop and the City’s Environmental Review Officer contacted in the event of discovery of the following cultural materials: concentrations of shellfish remains; evidence of fire (ashes, charcoal, burnt earth, fire-cracked rocks); concentrations of bones; recognizable Native American artifacts (arrowheads,



shell beads, stone mortars [bowls], humanly shaped rock); building foundation remains; trash pits, privies (outhouse holes); floor remains; wells; concentrations of bottles, broken dishes, shoes, buttons, cut animal bones, hardware, household items, barrels, etc.; thick layers of burned building debris (charcoal, nails, fused glass, burned plaster, burned dishes); wood structural remains (building, ship, wharf); clay roof/floor tiles; stone walls or footings; or gravestones. Prior to any soil-disturbing activities, each contractor shall be responsible for ensuring that the ALERT sheet is circulated to all field personnel, including machine operators, field crew, pile drivers, and supervisory personnel. The ALERT sheet shall also be posted in a visible location at the project site.

When Required: Prior to approval of construction-related permit; during construction

Initial Approval: Bureau of Building; Bureau of Planning

Monitoring/Inspection: Bureau of Building

**30. Human Remains – Discovery During Construction**

Requirement: Pursuant to CEQA Guidelines section 15064.5(e)(1), in the event that human skeletal remains are uncovered at the project site during construction activities, all work shall immediately halt and the project applicant shall notify the City and the Alameda County Coroner. If the County Coroner determines that an investigation of the cause of death is required or that the remains are Native American, all work shall cease within 50 feet of the remains until appropriate arrangements are made. In the event that the remains are Native American, the City shall contact the California Native American Heritage Commission (NAHC), pursuant to subdivision (c) of section 7050.5 of the California Health and Safety Code. If the agencies determine that avoidance is not feasible, then an alternative plan shall be prepared with specific steps and timeframe required to resume construction activities. Monitoring, data recovery, determination of significance, and avoidance measures (if applicable) shall be completed expeditiously and at the expense of the project applicant.

When Required: During construction

Initial Approval: N/A

Monitoring/Inspection: Bureau of Building

## **GEOLOGY AND SOILS**

**31. Construction-Related Permit(s)**

Requirement: The project applicant shall obtain all required construction-related permits/approvals from the City. The project shall comply with all standards, requirements and conditions contained in construction-related codes, including but not limited to the Oakland Building Code and the Oakland Grading Regulations, to ensure structural integrity and safe construction.

When Required: Prior to approval of construction-related permit

Initial Approval: Bureau of Building

Monitoring/Inspection: Bureau of Building

**32. Soils Report**

Requirement: The project applicant shall submit a soils report prepared by a registered geotechnical engineer for City review and approval. The soils report shall contain, at a minimum, field test results and observations regarding the nature, distribution and strength of existing soils, and recommendations for appropriate grading practices and project design. The project applicant shall implement the recommendations contained in the approved report during project design and construction.

When Required: Prior to approval of construction-related permit

Initial Approval: Bureau of Building

Monitoring/Inspection: Bureau of Building

**33. Seismic Hazards Zone (Landslide/Liquefaction)**

Requirement: The project applicant shall submit a site-specific geotechnical report, consistent with California Geological Survey Special Publication 117 (as amended), prepared by a registered geotechnical engineer for City review and approval containing at a minimum a description of the geological and geotechnical conditions at the site, an evaluation of site-specific seismic hazards based on geological and geotechnical conditions, and recommended measures to reduce potential impacts related to liquefaction and/or slope stability hazards. The project applicant shall implement the recommendations contained in the approved report during project design and construction.

When Required: Prior to approval of construction-related permit

Initial Approval: Bureau of Building

Monitoring/Inspection: Bureau of Building

## **GREENHOUSE GAS EMISSIONS / GLOBAL CLIMATE CHANGE**

**34. Greenhouse Gas (GHG) Reduction Plan**

***a. Greenhouse Gas (GHG) Reduction Plan Required***

Requirement: The project applicant shall retain a qualified air quality consultant to develop a Greenhouse Gas (GHG) Reduction Plan for City review and approval and shall implement the approved GHG Reduction Plan. The goal of the GHG Reduction Plan shall be to increase energy efficiency and reduce GHG emissions to below at least one of the Bay Area Quality Management District's (BAAQMD's) CEQA Thresholds of Significance (1,100 metric tons of CO<sub>2</sub>e per year or 4.6 metric tons of CO<sub>2</sub>e per year per service population) AND to reduce GHG emissions by 36 percent below the project's 2005 "business-as-usual" baseline GHG emissions(as explained below) to help implement the City's Energy and Climate Action Plan (adopted in 2012) which calls for reducing GHG emissions by 36 percent below 2005 levels. The GHG Reduction Plan shall include, at a minimum, (a) a detailed GHG emissions inventory for the project under a "business-as-usual" scenario with no consideration of project design features, or other energy efficiencies, (b) an "adjusted" baseline GHG emissions

inventory for the project, taking into consideration energy efficiencies included as part of the project (including the City's Standard Conditions of Approval, proposed mitigation measures, project design features, and other City requirements), and additional GHG reduction measures available to further reduce GHG emissions, and (c) requirements for ongoing monitoring and reporting to demonstrate that the additional GHG reduction measures are being implemented. If the project is to be constructed in phases, the GHG Reduction Plan shall provide GHG emission scenarios by phase.

Potential GHG reduction measures to be considered include, but are not be limited to, measures recommended in BAAQMD's latest CEQA Air Quality Guidelines, the California Air Resources Board Scoping Plan (December 2008, as may be revised), the California Air Pollution Control Officers Association (CAPCOA) Quantifying Greenhouse Gas Mitigation Measures (August 2010, as may be revised), the California Attorney General's website, and Reference Guides on Leadership in Energy and Environmental Design (LEED) published by the U.S. Green Building Council.

The types of allowable GHG reduction measures include the following (listed in order of City preference): (1) physical design features; (2) operational features; and (3) the payment of fees to fund GHG-reducing programs (i.e., the purchase of "carbon credits") as explained below.

The allowable locations of the GHG reduction measures include the following (listed in order of City preference): (1) the project site; (2) off-site within the City of Oakland; (3) off-site within the San Francisco Bay Area Air Basin; (4) off-site within the State of California; then (5) elsewhere in the United States.

As with preferred locations for the implementation of all GHG reductions measures, the preference for carbon credit purchases include those that can be achieved as follows (listed in order of City preference): (1) within the City of Oakland; (2) within the San Francisco Bay Area Air Basin; (3) within the State of California; then (4) elsewhere in the United States. The cost of carbon credit purchases shall be based on current market value at the time purchased and shall be based on the project's operational emissions estimated in the GHG Reduction Plan or subsequent approved emissions inventory, which may result in emissions that are higher or lower than those estimated in the GHG Reduction Plan.

For physical GHG reduction measures to be incorporated into the design of the project, the measures shall be included on the drawings submitted for construction-related permits.

When Required: Prior to approval of construction-related permit.

Initial Approval: Bureau of Planning

Monitoring/Inspection: N/A

**b. *GHG Reduction Plan Implementation During Construction***

Requirement: The project applicant shall implement the GHG Reduction Plan during construction of the project. For physical GHG reduction measures to be incorporated into the design of the project, the measures shall be implemented during construction. For physical GHG reduction measures to be incorporated into off-site projects, the project applicant shall obtain all necessary permits/approvals and the measures shall be included on drawings and submitted to the City Planning Director or his/her designee for review and approval. These off-site improvements shall be installed prior to completion of the subject project (or prior to completion of the project phase for phased projects). For GHG reduction measures involving the purchase of carbon credits, evidence of the payment/purchase shall be submitted to the

City for review and approval prior to completion of the project (or prior to completion of the project phase, for phased projects).

When Required: During construction

Initial Approval: Bureau of Planning

Monitoring/Inspection: Bureau of Building

**c. *GHG Reduction Plan Implementation After Construction***

Requirement: The project applicant shall implement the GHG Reduction Plan after construction of the project (or at the completion of the project phase for phased projects). For operational GHG reduction measures to be incorporated into the project or off-site projects, the measures shall be implemented on an indefinite and ongoing basis.

The project applicant shall satisfy the following requirements for ongoing monitoring and reporting to demonstrate that the additional GHG reduction measures are being implemented. The GHG Reduction Plan requires regular periodic evaluation over the life of the project (generally estimated to be at least 40 years) to determine how the Plan is achieving required GHG emissions reductions over time, as well as the efficacy of the specific additional GHG reduction measures identified in the Plan.

**Annual Report.** Implementation of the GHG reduction measures and related requirements shall be ensured through compliance with Conditions of Approval adopted for the project. Generally, starting two years after the City issues the first Certificate of Occupancy for the project, the project applicant shall prepare each year of the useful life of the project an Annual GHG Emissions Reduction Report (“Annual Report”), for review and approval by the City Planning Director or his/her designee. The Annual Report shall be submitted to an independent reviewer of the City’s choosing, to be paid for by the project applicant.

The Annual Report shall summarize the project’s implementation of GHG reduction measures over the preceding year, intended upcoming changes, compliance with the conditions of the Plan, and include a brief summary of the previous year’s Annual Report results (starting the second year). The Annual Report shall include a comparison of annual project emissions to the baseline emissions reported in the GHG Plan.

The GHG Reduction Plan shall be considered fully attained when project emissions are less than either applicable numeric BAAQMD CEQA Thresholds AND GHG emissions are 36 percent below the project’s 2005 “business-as-usual” baseline GHG emissions, as confirmed by the City through an established monitoring program. Monitoring and reporting activities will continue at the City’s discretion, as discussed below.

**Corrective Procedure.** If the third Annual Report, or any report thereafter, indicates that, in spite of the implementation of the GHG Reduction Plan, the project is not achieving the GHG reduction goal, the project applicant shall prepare a report for City review and approval, which proposes additional or revised GHG measures to better achieve the GHG emissions reduction goals, including without limitation, a discussion on the feasibility and effectiveness of the menu of other additional measures (“Corrective GHG Action Plan”). The project applicant shall then implement the approved Corrective GHG Action Plan.

If, one year after the Corrective GHG Action Plan is implemented, the required GHG emissions reduction target is still not being achieved, or if the project applicant fails to submit a report at the times described above, or if the reports do not meet City requirements outlined above, the City may, in addition to its other remedies, (a) assess the project applicant a

financial penalty based upon actual percentage reduction in GHG emissions as compared to the percent reduction in GHG emissions established in the GHG Reduction Plan; or (b) refer the matter to the City Planning Commission for scheduling of a compliance hearing to determine whether the project's approvals should be revoked, altered or additional conditions of approval imposed.

The penalty as described in (a) above shall be determined by the City Planning Director or his/her designee and be commensurate with the percentage GHG emissions reduction not achieved (compared to the applicable numeric significance thresholds) or required percentage reduction from the "adjusted" baseline.

In determining whether a financial penalty or other remedy is appropriate, the City shall not impose a penalty if the project applicant has made a good faith effort to comply with the GHG Reduction Plan.

The City would only have the ability to impose a monetary penalty after a reasonable cure period and in accordance with the enforcement process outlined in Planning Code Chapter 17.152. If a financial penalty is imposed, such penalty sums shall be used by the City solely toward the implementation of the GHG Reduction Plan.

**Timeline Discretion and Summary.** The City shall have the discretion to reasonably modify the timing of reporting, with reasonable notice and opportunity to comment by the applicant, to coincide with other related monitoring and reporting required for the project.

When Required: Ongoing

Initial Approval: Bureau of Planning

Monitoring/Inspection: Bureau of Planning

## **HAZARDS AND HAZARDOUS MATERIALS**

### **35. Hazardous Materials Related to Construction**

Requirement: The project applicant shall ensure that Best Management Practices (BMPs) are implemented by the contractor during construction to minimize potential negative effects on groundwater, soils, and human health. These shall include, at a minimum, the following:

- a. Follow manufacture's recommendations for use, storage, and disposal of chemical products used in construction;
- b. Avoid overtopping construction equipment fuel gas tanks;
- c. During routine maintenance of construction equipment, properly contain and remove grease and oils;
- d. Properly dispose of discarded containers of fuels and other chemicals;
- e. Implement lead-safe work practices and comply with all local, regional, state, and federal requirements concerning lead (for more information refer to the Alameda County Lead Poisoning Prevention Program); and
- f. If soil, groundwater, or other environmental medium with suspected contamination is encountered unexpectedly during construction activities (e.g., identified by odor or visual staining, or if any underground storage tanks, abandoned drums or other hazardous materials or wastes are encountered), the project applicant shall cease work in the vicinity of the suspect

material, the area shall be secured as necessary, and the applicant shall take all appropriate measures to protect human health and the environment. Appropriate measures shall include notifying the City and applicable regulatory agency(ies) and implementation of the actions described in the City’s Standard Conditions of Approval, as necessary, to identify the nature and extent of contamination. Work shall not resume in the area(s) affected until the measures have been implemented under the oversight of the City or regulatory agency, as appropriate.

When Required: During construction

Initial Approval: N/A

Monitoring/Inspection: Bureau of Building

**36. Hazardous Building Materials and Site Contamination**

***a. Hazardous Building Materials Assessment***

Requirement: The project applicant shall submit a comprehensive assessment report to the Bureau of Building, signed by a qualified environmental professional, documenting the presence or lack thereof of asbestos-containing materials (ACMs), lead-based paint, polychlorinated biphenyls (PCBs), and any other building materials or stored materials classified as hazardous materials by State or federal law. If lead-based paint, ACMs, PCBs, or any other building materials or stored materials classified as hazardous materials are present, the project applicant shall submit specifications prepared and signed by a qualified environmental professional, for the stabilization and/or removal of the identified hazardous materials in accordance with all applicable laws and regulations. The project applicant shall implement the approved recommendations and submit to the City evidence of approval for any proposed remedial action and required clearances by the applicable local, state, or federal regulatory agency.

When Required: Prior to approval of demolition, grading, or building permits

Initial Approval: Bureau of Building

Monitoring/Inspection: Bureau of Building

***b. Environmental Site Assessment Required***

Requirement: The project applicant shall submit a Phase I Environmental Site Assessment report, and Phase II Environmental Site Assessment report if warranted by the Phase I report, for the project site for review and approval by the City. The report(s) shall be prepared by a qualified environmental assessment professional and include recommendations for remedial action, as appropriate, for hazardous materials. The project applicant shall implement the approved recommendations and submit to the City evidence of approval for any proposed remedial action and required clearances by the applicable local, state, or federal regulatory agency.

When Required: Prior to approval of construction-related permit.

Initial Approval: Applicable regulatory agency with jurisdiction

Monitoring/Inspection: Applicable regulatory agency with jurisdiction

***c. Health and Safety Plan Required***

Requirement: The project applicant shall submit a Health and Safety Plan for the review and approval by the City in order to protect project construction workers from risks associated with hazardous materials. The project applicant shall implement the approved Plan.

When Required: Prior to approval of construction-related permit

Initial Approval: Bureau of Building

Monitoring/Inspection: Bureau of Building

**d. *Best Management Practices (BMPs) Required for Contaminated Sites***

Requirement: The project applicant shall ensure that Best Management Practices (BMPs) are implemented by the contractor during construction to minimize potential soil and groundwater hazards. These shall include the following:

- i. Soil generated by construction activities shall be stockpiled on-site in a secure and safe manner. All contaminated soils determined to be hazardous or non-hazardous waste must be adequately profiled (sampled) prior to acceptable reuse or disposal at an appropriate off-site facility. Specific sampling and handling and transport procedures for reuse or disposal shall be in accordance with applicable local, state, and federal requirements.
- ii. Groundwater pumped from the subsurface shall be contained on-site in a secure and safe manner, prior to treatment and disposal, to ensure environmental and health issues are resolved pursuant to applicable laws and policies. Engineering controls shall be utilized, which include impermeable barriers to prohibit groundwater and vapor intrusion into the building.

When Required: During construction

Initial Approval: N/A

Monitoring/Inspection: Bureau of Building

**37. Fire Safety Phasing Plan**

Requirement: The project applicant shall submit a Fire Safety Phasing Plan for City review and approval, and shall implement the approved Plan. The Fire Safety Phasing Plan shall include all of the fire safety features incorporated into each phase of the project and the schedule for implementation of the features.

When Required: Prior to approval of construction-related permit

Initial Approval: Oakland Fire Department

Monitoring/Inspection: Bureau of Building

## **HYDROLOGY AND WATER QUALITY**

**38. Erosion and Sedimentation Control Plan for Construction**

**a. *Erosion and Sedimentation Control Plan Required***

Requirement: The project applicant shall submit an Erosion and Sedimentation Control Plan to the City for review and approval. The Erosion and Sedimentation Control Plan shall include all necessary measures to be taken to prevent excessive stormwater runoff or carrying by stormwater runoff of solid materials on to lands of adjacent property owners, public streets, or to creeks as a result of conditions created by grading and/or construction operations. The Plan shall include, but not be limited to, such measures as short-term erosion

control planting, waterproof slope covering, check dams, interceptor ditches, benches, storm drains, dissipation structures, diversion dikes, retarding berms and barriers, devices to trap, store and filter out sediment, and stormwater retention basins. Off-site work by the project applicant may be necessary. The project applicant shall obtain permission or easements necessary for off-site work. There shall be a clear notation that the plan is subject to changes as changing conditions occur. Calculations of anticipated stormwater runoff and sediment volumes shall be included, if required by the City. The Plan shall specify that, after construction is complete, the project applicant shall ensure that the storm drain system shall be inspected and that the project applicant shall clear the system of any debris or sediment.

When Required: Prior to approval of construction-related permit

Initial Approval: Bureau of Building

Monitoring/Inspection: N/A

***b. Erosion and Sedimentation Control During Construction***

Requirement: The project applicant shall implement the approved Erosion and Sedimentation Control Plan. No grading shall occur during the wet weather season (October 15 through April 15) unless specifically authorized in writing by the Bureau of Building.

When Required: During construction

Initial Approval: N/A

Monitoring/Inspection: Bureau of Building

**39. State Construction General Permit**

Requirement: The project applicant shall comply with the requirements of the Construction General Permit issued by the State Water Resources Control Board (SWRCB). The project applicant shall submit a Notice of Intent (NOI), Stormwater Pollution Prevention Plan (SWPPP), and other required Permit Registration Documents to SWRCB. The project applicant shall submit evidence of compliance with Permit requirements to the City.

When Required: Prior to approval of construction-related permit

Initial Approval: State Water Resources Control Board; evidence of compliance submitted to Bureau of Building

Monitoring/Inspection: State Water Resources Control Board

**40. Site Design Measures to Reduce Stormwater Runoff**

Requirement: Pursuant to Provision C.3 of the Municipal Regional Stormwater Permit issued under the National Pollutant Discharge Elimination System (NPDES), the project applicant is encouraged to incorporate appropriate site design measures into the project to reduce the amount of stormwater runoff. These measures may include, but are not limited to, the following:

- a. Minimize impervious surfaces, especially directly connected impervious surfaces and surface parking areas;
- b. Utilize permeable paving in place of impervious paving where appropriate;
- c. Cluster structures;
- d. Direct roof runoff to vegetated areas;



- e. Preserve quality open space; and
- f. Establish vegetated buffer areas.

When Required: Ongoing

Initial Approval: N/A

Monitoring/Inspection: N/A

**41. NPDES C.3 Stormwater Requirements for Regulated Projects**

***a. Post-Construction Stormwater Management Plan Required***

Requirement: The project applicant shall comply with the requirements of Provision C.3 of the Municipal Regional Stormwater Permit issued under the National Pollutant Discharge Elimination System (NPDES). The project applicant shall submit a Post-Construction Stormwater Management Plan to the City for review and approval with the project drawings submitted for site improvements, and shall implement the approved Plan during construction. The Post-Construction Stormwater Management Plan shall include and identify the following:

- i. Location and size of new and replaced impervious surface;
- ii. Directional surface flow of stormwater runoff;
- iii. Location of proposed on-site storm drain lines;
- iv. Site design measures to reduce the amount of impervious surface area;
- v. Source control measures to limit stormwater pollution;
- vi. Stormwater treatment measures to remove pollutants from stormwater runoff, including the method used to hydraulically size the treatment measures; and
- vii. Hydromodification management measures, if required by Provision C.3, so that post-project stormwater runoff flow and duration match pre-project runoff.

When Required: Prior to approval of construction-related permit

Initial Approval: Bureau of Planning; Bureau of Building

Monitoring/Inspection: Bureau of Building

***b. Maintenance Agreement Required***

Requirement: The project applicant shall enter into a maintenance agreement with the City, based on the Standard City of Oakland Stormwater Treatment Measures Maintenance Agreement, in accordance with Provision C.3, which provides, in part, for the following:

- i. The project applicant accepting responsibility for the adequate installation/construction, operation, maintenance, inspection, and reporting of any on-site stormwater treatment measures being incorporated into the project until the responsibility is legally transferred to another entity; and
- ii. Legal access to the on-site stormwater treatment measures for representatives of the City, the local vector control district, and staff of the Regional Water Quality Control Board, San Francisco Region, for the purpose of verifying the implementation, operation, and maintenance of the on-site stormwater treatment measures and to take corrective action if necessary.

The maintenance agreement shall be recorded at the County Recorder's Office at the applicant's expense.

When Required: Prior to building permit final

Initial Approval: Bureau of Building

Monitoring/Inspection: Bureau of Building

## **NOISE**

### **42. Construction Days/Hours**

Requirement: The project applicant shall comply with the following restrictions concerning construction days and hours:

- a. Construction activities are limited to between 7:00 a.m. and 7:00 p.m. Monday through Friday, except that pier drilling and/or other extreme noise generating activities greater than 90 dBA shall be limited to between 8:00 a.m. and 4:00 p.m.
- b. Construction activities are limited to between 9:00 a.m. and 5:00 p.m. on Saturday. In residential zones and within 300 feet of a residential zone, construction activities are allowed from 9:00 a.m. to 5:00 p.m. only within the interior of the building with the doors and windows closed. No pier drilling or other extreme noise generating activities greater than 90 dBA are allowed on Saturday.
- c. No construction is allowed on Sunday or federal holidays.

Construction activities include, but are not limited to, truck idling, moving equipment (including trucks, elevators, etc.) or materials, deliveries, and construction meetings held on-site in a non-enclosed area.

Any construction activity proposed outside of the above days and hours for special activities (such as concrete pouring which may require more continuous amounts of time) shall be evaluated on a case-by-case basis by the City, with criteria including the urgency/emergency nature of the work, the proximity of residential or other sensitive uses, and a consideration of nearby residents'/occupants' preferences. The project applicant shall notify property owners and occupants located within 300 feet at least 14 calendar days prior to construction activity proposed outside of the above days/hours. When submitting a request to the City to allow construction activity outside of the above days/hours, the project applicant shall submit information concerning the type and duration of proposed construction activity and the draft public notice for City review and approval prior to distribution of the public notice.

When Required: During construction

Initial Approval: N/A

Monitoring/Inspection: Bureau of Building

### **43. Construction Noise**

Requirement: The project applicant shall implement noise reduction measures to reduce noise impacts due to construction. Noise reduction measures include, but are not limited to, the following:

- a. Equipment and trucks used for project construction shall utilize the best available noise control techniques (e.g., improved mufflers, equipment redesign, use of intake silencers, ducts, engine enclosures and acoustically-attenuating shields or shrouds) wherever feasible.

- b. Except as provided herein, impact tools (e.g., jack hammers, pavement breakers, and rock drills) used for project construction shall be hydraulically or electrically powered to avoid noise associated with compressed air exhaust from pneumatically powered tools. However, where use of pneumatic tools is unavoidable, an exhaust muffler on the compressed air exhaust shall be used; this muffler can lower noise levels from the exhaust by up to about 10 dBA. External jackets on the tools themselves shall be used, if such jackets are commercially available, and this could achieve a reduction of 5 dBA. Quieter procedures shall be used, such as drills rather than impact equipment, whenever such procedures are available and consistent with construction procedures.
- c. Applicant shall use temporary power poles instead of generators where feasible.
- d. Stationary noise sources shall be located as far from adjacent properties as possible, and they shall be muffled and enclosed within temporary sheds, incorporate insulation barriers, or use other measures as determined by the City to provide equivalent noise reduction.
- e. The noisiest phases of construction shall be limited to less than 10 days at a time. Exceptions may be allowed if the City determines an extension is necessary and all available noise reduction controls are implemented.

When Required: During construction

Initial Approval: N/A

Monitoring/Inspection: Bureau of Building

#### **44. Extreme Construction Noise**

##### ***a. Construction Noise Management Plan Required***

Requirement: Prior to any extreme noise generating construction activities (e.g., pier drilling, pile driving and other activities generating greater than 90dBA), the project applicant shall submit a Construction Noise Management Plan prepared by a qualified acoustical consultant for City review and approval that contains a set of site-specific noise attenuation measures to further reduce construction impacts associated with extreme noise generating activities. The project applicant shall implement the approved Plan during construction. Potential attenuation measures include, but are not limited to, the following:

- i. Erect temporary plywood noise barriers around the construction site, particularly along on sites adjacent to residential buildings;
- ii. Implement “quiet” pile driving technology (such as pre-drilling of piles, the use of more than one pile driver to shorten the total pile driving duration), where feasible, in consideration of geotechnical and structural requirements and conditions;
- iii. Utilize noise control blankets on the building structure as the building is erected to reduce noise emission from the site;
- iv. Evaluate the feasibility of noise control at the receivers by temporarily improving the noise reduction capability of adjacent buildings by the use of sound blankets for example and implement such measure if such measures are feasible and would noticeably reduce noise impacts; and
- v. Monitor the effectiveness of noise attenuation measures by taking noise measurements.

When Required: Prior to approval of construction-related permit

Initial Approval: Bureau of Building

Monitoring/Inspection: Bureau of Building

***b. Public Notification Required***

Requirement: The project applicant shall notify property owners and occupants located within 300 feet of the construction activities at least 14 calendar days prior to commencing extreme noise generating activities. Prior to providing the notice, the project applicant shall submit to the City for review and approval the proposed type and duration of extreme noise generating activities and the proposed public notice. The public notice shall provide the estimated start and end dates of the extreme noise generating activities and describe noise attenuation measures to be implemented.

When Required: During construction

Initial Approval: Bureau of Building

Monitoring/Inspection: Bureau of Building

**45. Construction Noise Complaints**

Requirement: The project applicant shall submit to the City for review and approval a set of procedures for responding to and tracking complaints received pertaining to construction noise, and shall implement the procedures during construction. At a minimum, the procedures shall include:

- a. Designation of an on-site construction complaint and enforcement manager for the project;
- b. A large on-site sign near the public right-of-way containing permitted construction days/hours, complaint procedures, and phone numbers for the project complaint manager and City Code Enforcement unit;
- c. Protocols for receiving, responding to, and tracking received complaints; and
- d. Maintenance of a complaint log that records received complaints and how complaints were addressed, which shall be submitted to the City for review upon the City's request.

When Required: Prior to approval of construction-related permit

Initial Approval: Bureau of Building

Monitoring/Inspection: Bureau of Building

**46. Exposure to Community Noise**

Requirement: The project applicant shall submit a Noise Reduction Plan prepared by a qualified acoustical engineer for City review and approval that contains noise reduction measures (e.g., sound-rated window, wall, and door assemblies) to achieve an acceptable interior noise level in accordance with the land use compatibility guidelines of the Noise Element of the Oakland General Plan. The applicant shall implement the approved Plan during construction. To the maximum extent practicable, interior noise levels shall not exceed the following:

- a. 45 dBA: Residential activities, civic activities, hotels
- b. 50 dBA: Administrative offices; group assembly activities
- c. 55 dBA: Commercial activities
- d. 65 dBA: Industrial activities

When Required: Prior to approval of construction-related permit

Initial Approval: Bureau of Planning

Monitoring/Inspection: Bureau of Building

**47. Operational Noise**

Requirement: Noise levels from the project site after completion of the project (i.e., during project operation) shall comply with the performance standards of chapter 17.120 of the Oakland Planning Code and chapter 8.18 of the Oakland Municipal Code. If noise levels exceed these standards, the activity causing the noise shall be abated until appropriate noise reduction measures have been installed and compliance verified by the City.

When Required: Ongoing

Initial Approval: N/A

Monitoring/Inspection: Bureau of Building

## **POPULATION AND HOUSING**

**48. Jobs/Housing Impact Fee**

Requirement: The project applicant shall comply with the requirements of the City of Oakland Jobs/Housing Impact Fee Ordinance (chapter 15.68 of the Oakland Municipal Code).

When Required: Prior to issuance of building permit; subsequent milestones pursuant to ordinance

Initial Approval: Bureau of Building

Monitoring/Inspection: N/A

## **PUBLIC SERVICES**

**49. Capital Improvements Impact Fee**

Requirement: The project applicant shall comply with the requirements of the City of Oakland Capital Improvements Fee Ordinance (chapter 15.74 of the Oakland Municipal Code).

When Required: Prior to issuance of building permit

Initial Approval: Bureau of Building

Monitoring/Inspection: N/A

## **TRANSPORTATION/TRAFFIC**

**50. Construction Activity in the Public Right-of-Way**

*c. Obstruction Permit Required*

Requirement: The project applicant shall obtain an obstruction permit from the City prior to placing any temporary construction-related obstruction in the public right-of-way, including City streets, sidewalks, bicycle facilities, and bus stops.

When Required: Prior to approval of construction-related permit

Initial Approval: Department of Transportation

Monitoring/Inspection: Department of Transportation

**d. *Traffic Control Plan Required***

Requirement: In the event of obstructions to vehicle or bicycle travel lanes, bus stops, or sidewalks, the project applicant shall submit a Traffic Control Plan to the City for review and approval prior to obtaining an obstruction permit. The project applicant shall submit evidence of City approval of the Traffic Control Plan with the application for an obstruction permit. The Traffic Control Plan shall contain a set of comprehensive traffic control measures for auto, transit, bicycle, and pedestrian accommodations (or detours, if accommodations are not feasible), including detour signs if required, lane closure procedures, signs, cones for drivers, and designated construction access routes. The Traffic Control Plan shall be in conformance with the City's Supplemental Design Guidance for Accommodating Pedestrians, Bicyclists, and Bus Facilities in Construction Zones. The project applicant shall implement the approved Plan during construction.

Initial Approval: Department of Transportation

Monitoring/Inspection: Department of Transportation

**e. *Repair of City Streets***

Requirement: The project applicant shall repair any damage to the public right-of way, including streets and sidewalks, caused by project construction at his/her expense within one week of the occurrence of the damage (or excessive wear), unless further damage/excessive wear may continue; in such case, repair shall occur prior to approval of the final inspection of the construction-related permit. All damage that is a threat to public health or safety shall be repaired immediately.

When Required: Prior to building permit final

Initial Approval: N/A

Monitoring/Inspection: Department of Transportation

**51. Bicycle Parking**

Requirement: The project applicant shall comply with the City of Oakland Bicycle Parking Requirements (Chapter 17.1178 of the Oakland Planning Code). The project drawings submitted for construction-related permits shall demonstrate compliance with the requirements.

When Required: Prior to approval of construction-related permit

Initial Approval: Bureau of Planning

Monitoring/Inspection: Bureau of Building

**52. Transportation Improvements**

Requirement: The project applicant shall implement the recommended on- and off-site transportation-related improvements contained within the Transportation Impact Review for the project (e.g., signal timing adjustments, restriping, signalization, traffic control devices, roadway

reconfigurations, transportation demand management measures, and transit, pedestrian, and bicyclist amenities). The project applicant is responsible for funding and installing the improvements, and shall obtain all necessary permits and approvals from the City and/or other applicable regulatory agencies such as, but not limited to, Caltrans (for improvements related to Caltrans facilities), the California Public Utilities Commission (for improvements related to railroad crossings), BART, and AC Transit prior to installing the improvements. To implement this measure for intersection modifications, the project applicant shall submit Plans, Specifications, and Estimates (PS&E) to the City for review and approval. All elements shall be designed to applicable City standards in effect at the time of construction and all new or upgraded signals shall include these enhancements as required by the City. All other facilities supporting vehicle travel and alternative modes through the intersection shall be brought up to both City standards and ADA standards (according to Federal and State Access Board guidelines) at the time of construction. Current City Standards call for, among other items, the elements listed below:

- a. 2070L Type Controller with cabinet accessory
- b. GPS communication (clock)
- c. Accessible pedestrian crosswalks according to Federal and State Access Board guidelines with signals (audible and tactile)
- d. Countdown pedestrian head module switch out
- e. City Standard ADA wheelchair ramps
- f. Video detection on existing (or new, if required)
- g. Mast arm poles, full activation (where applicable)
- h. Polara Push buttons (full activation)
- i. Bicycle detection (full activation)
- j. Pull boxes
- k. Signal interconnect and communication with trenching (where applicable), or through existing conduit (where applicable), 600 feet maximum
- l. Conduit replacement contingency
- m. Fiber switch
- n. PTZ camera (where applicable)
- o. Transit Signal Priority (TSP) equipment consistent with other signals along corridor
- p. Signal timing plans for the signals in the coordination group
- q. Bi-directional curb ramps (where feasible, and if project is on a street corner)
- r. Upgrade ramps on receiving curb (where feasible, and if project is on a street corner)

The following improvements shall be submitted as part of the FDP for horizontal and public improvements and a p-job application for review and approval by the Department of Transportation (DOT). If approved they shall be implemented.

Requirement #1. Ensure that the garage driveway on Chester Street and the loading docks for each project building provide adequate sight distance between vehicles exiting the garage and pedestrians on the adjacent sidewalk.

Requirement #2. Implement the following at the 7th Street/Mandela Parkway intersection:

- o Convert the existing through/right-turn lane on the westbound 7th Street approach to a right-turn/bus only lane, and remove the merge lane on westbound 7th Street west of the intersection
- o Modify the signal timings at the intersection to provide a bus only phase for the westbound approach, and reduce the signal cycle length to 90 seconds

Requirement #3. After the completion of the first phase of the project, conduct a signal warrant analysis at the 7th Street/Chester Street intersection to determine if and when the intersection should be signalized. If signalization is warranted, the project shall signalize the intersection with protected left-turn phasing for the east/west 7<sup>th</sup> Street approaches. In addition, and as determined by the City of Oakland staff, the signal may be interconnected with existing adjacent signals along 7th Street. If signalization is not warranted, the project shall conduct an analysis to determine if other control devices, such as all-way stop controls, or rectangular rapid flash beacon (RRFB) should be installed at the intersection. The project shall implement the recommended improvement at the intersection as approved by the City of Oakland.

Requirement #4. Ensure that the Ford GoBike station currently located in-street on 7th Street just east of Center Street is relocated on the BART Station Plaza to provide close and convenient access to the West Oakland BART station and the bicycle facilities adjacent to the project site.

Requirement #5. Explore the feasibility of (and implement, if feasible) installing curb extensions (bulb-outs) and directional curb ramps with truncated domes at the following locations:

- o Southwest corner of the 7th Street/Chester Street intersection.
- o All four corners of the 5th Street/Mandela Parkway intersection and curb extensions (bulb-outs) across the 5th Street approaches of the southwest and northeast corners.

Requirement #6. Provide all-way stop control at the 5th Street/Center Street and 5th Street/Chester Street intersection.

Requirement #7. If reviewed and approved by BART and Oakland Fire Department, provide rolled curb instead of curb cuts for emergency vehicle access points on Chester Street and Mandela Parkway.

Requirement #8. Install a pedestrian scramble at the 7th Street/Center Street intersection.

Requirement #9. Coordinate with the City of Oakland and the appropriate property owners to determine the feasibility of and if deemed feasible, complete the sidewalk gap on the south side of 5th Street just east of Center Street.

Requirement #10. Work with the City to designate a bus stop for intercity coaches (e.g., Megabus and Bolt) and other shuttles on 7th Street between Henry and Chester Streets.



Requirement #11. Install improvement measures at the proposed mid-block crossing on Mandela Parkway, such as raised crosswalk, Rectangular Rapid Flash Beacon (RRFB), or other measures as approved by the City of Oakland.

When Required: Prior to issuance of first building permit final or as otherwise specified in the requirements above or in Condition #72

Initial Approval: Bureau of Building; Department of Transportation

Monitoring/Inspection: Bureau of Building

**53. Transportation and Parking Demand Management**

***a. Transportation and Parking Demand Management (TDM) Plan Required***

Requirement: The project applicant shall submit a Transportation and Parking Demand Management (TDM) Plan for review and approval by the City.

- i. The goals of the TDM Plan shall be the following:
  - Reduce vehicle traffic and parking demand generated by the project to the maximum extent practicable.
  - Achieve the following project vehicle trip reductions (VTR):
    - Projects generating 50-99 net new a.m. or p.m. peak hour vehicle trips: 10 percent VTR
    - Projects generating 100 or more net new a.m. or p.m. peak hour vehicle trips: 20 percent VTR
  - Increase pedestrian, bicycle, transit, and carpool/vanpool modes of travel. All four modes of travel shall be considered, as appropriate.
  - Enhance the City’s transportation system, consistent with City policies and programs.
- ii. The TDM Plan should include the following:
  - Baseline existing conditions of parking and curbside regulations within the surrounding neighborhood that could affect the effectiveness of TDM strategies, including inventory of parking spaces and occupancy if applicable.
  - Proposed TDM strategies to achieve VTR goals (see below).
- iii. For employers with 100 or more employees at the subject site, the TDM Plan shall also comply with the requirements of Oakland Municipal Code Chapter 10.68 Employer-Based Trip Reduction Program.
- iv. The following TDM strategies **must** be incorporated into a TDM Plan based on a project location or other characteristics. When required, these mandatory strategies should be identified as a credit toward a project’s VTR.

<b>Improvement</b>	<b>Required by code or when...</b>
<b>Bus boarding bulbs or islands</b>	<ul style="list-style-type: none"> <li>• A bus boarding bulb or island does not already exist and a bus stop is located along the project frontage; and/or</li> </ul>

<b>Improvement</b>	<b>Required by code or when...</b>
	<ul style="list-style-type: none"> <li>• A bus stop along the project frontage serves a route with 15 minutes or better peak hour service and has a shared bus-bike lane curb</li> </ul>
<b>Bus shelter</b>	<ul style="list-style-type: none"> <li>• A stop with no shelter is located within the project frontage, or</li> <li>• The project is located within 0.10 miles of a flag stop with 25 or more boardings per day</li> </ul>
<b>Concrete bus pad</b>	<ul style="list-style-type: none"> <li>• A bus stop is located along the project frontage and a concrete bus pad does not already exist</li> </ul>
<b>Curb extensions or bulb-outs</b>	<ul style="list-style-type: none"> <li>• Identified as an improvement within site analysis</li> </ul>
<b>Implementation of a corridor-level bikeway improvement</b>	<ul style="list-style-type: none"> <li>• A buffered Class II or Class IV bikeway facility is in a local or county adopted plan within 0.10 miles of the project location; and</li> <li>• The project would generate 500 or more daily bicycle trips</li> </ul>
<b>Implementation of a corridor-level transit capital improvement</b>	<ul style="list-style-type: none"> <li>• A high-quality transit facility is in a local or county adopted plan within 0.25 miles of the project location; and</li> <li>• The project would generate 400 or more peak period transit trips</li> </ul>
<b>Installation of amenities such as lighting; pedestrian-oriented green infrastructure, trees, or other greening landscape; and trash receptacles per the Pedestrian Master Plan and any applicable streetscape plan.</b>	<ul style="list-style-type: none"> <li>• Always required</li> </ul>
<b>Installation of safety improvements identified in the Pedestrian Master Plan (such as crosswalk striping, curb ramps, count down signals, bulb outs, etc.)</b>	<ul style="list-style-type: none"> <li>• When improvements are identified in the Pedestrian Master Plan along project frontage or at an adjacent intersection</li> </ul>
<b>In-street bicycle corral</b>	<ul style="list-style-type: none"> <li>• A project includes more than 10,000 square feet of ground floor retail, is located along a Tier 1 bikeway, and on-street vehicle parking is provided along the project frontages.</li> </ul>

<b>Improvement</b>	<b>Required by code or when...</b>
<b>Intersection improvements<sup>1</sup></b>	<ul style="list-style-type: none"> <li>Identified as an improvement within site analysis</li> </ul>
<b>New sidewalk, curb ramps, curb and gutter meeting current City and ADA standards</b>	<ul style="list-style-type: none"> <li>Always required</li> </ul>
<b>No monthly permits and establish minimum price floor for public parking<sup>2</sup></b>	<ul style="list-style-type: none"> <li>If proposed parking ratio exceeds 1:1000 sf. (commercial)</li> </ul>
<b>Parking garage is designed with retrofit capability</b>	<ul style="list-style-type: none"> <li>Optional if proposed parking ratio exceeds 1:1.25 (residential) or 1:1000 sf. (commercial)</li> </ul>
<b>Parking space reserved for car share</b>	<ul style="list-style-type: none"> <li>If a project is providing parking and a project is located within downtown. One car share space reserved for buildings between 50 – 200 units, then one car share space per 200 units.</li> </ul>
<b>Paving, lane striping or restriping (vehicle and bicycle), and signs to midpoint of street section</b>	<ul style="list-style-type: none"> <li>Typically required</li> </ul>
<b>Pedestrian crossing improvements</b>	<ul style="list-style-type: none"> <li>Identified as an improvement within site analysis</li> </ul>
<b>Pedestrian-supportive signal changes<sup>3</sup></b>	<ul style="list-style-type: none"> <li>Identified as an improvement within operations analysis</li> </ul>
<b>Real-time transit information system</b>	<ul style="list-style-type: none"> <li>A project frontage block includes a bus stop or BART station and is along a Tier 1 transit route with 2 or more routes or peak period frequency of 15 minutes or better</li> </ul>
<b>Relocating bus stops to far side</b>	<ul style="list-style-type: none"> <li>A project is located within 0.10 mile of any active bus stop that is currently near-side</li> </ul>
<b>Signal upgrades<sup>4</sup></b>	<ul style="list-style-type: none"> <li>Project size exceeds 100 residential units, 80,000 sf. of retail, or 100,000 sf. of commercial; and</li> <li>Project frontage abuts an intersection with signal infrastructure older than 15 years</li> </ul>
<b>Transit queue jumps</b>	<ul style="list-style-type: none"> <li>Identified as a needed improvement within operations</li> </ul>

<sup>1</sup> Including but not limited to visibility improvements, shortening corner radii, pedestrian safety islands, accounting for pedestrian desire lines.

<sup>2</sup> May also provide a cash incentive or transit pass alternative to a free parking space in commercial properties.

<sup>3</sup> Including but not limited to reducing signal cycle lengths to less than 90 seconds to avoid pedestrian crossings against the signal, providing a leading pedestrian interval, provide a “scramble” signal phase where appropriate.

<sup>4</sup> Including typical traffic lights, pedestrian signals, bike actuated signals, transit-only signals

Improvement	Required by code or when...
	analysis of a project with frontage along a Tier 1 transit route with 2 or more routes or peak period frequency of 15 minutes or better
<b>Transit Operations</b>	<ul style="list-style-type: none"> <li>• The project applicant shall, if feasible, contribute its fair share to AC Transit service enhancements to meet access goals outlined in the City of Oakland West Oakland Specific Plan and AC Transit’s ACgo expanded service plan and improve connections to local goods and services. Alternatively, the project applicant may explore and propose other TDM measure(s), including those already set forth in the TDM plan, in lieu of this fair share contribution. The City may approve the substitute TDM measure(s) if the City, in its discretion, deems the measure(s) more feasible, reasonably related, and roughly proportional to the impacts of the development.</li> </ul>
<b>Trenching and placement of conduit for providing traffic signal interconnect</b>	<ul style="list-style-type: none"> <li>• Project size exceeds 100 units, 80,000 sf. of retail, or 100,000 sf. of commercial; and</li> <li>• Project frontage block is identified for signal interconnect improvements as part of a planned ITS improvement; and</li> <li>• A major transit improvement is identified within operations analysis requiring traffic signal interconnect</li> </ul>
<b>Unbundled parking</b>	<ul style="list-style-type: none"> <li>• If proposed parking ratio exceeds 1:1.25 (residential)</li> </ul>

- v. Other TDM strategies to consider include, but are not limited to, the following:
- Inclusion of additional long-term and short-term bicycle parking that meets the design standards set forth in chapter five of the Bicycle Master Plan and the Bicycle Parking Ordinance (chapter 17.117 of the Oakland Planning Code), and shower and locker facilities in commercial developments that exceed the requirement.
  - Construction of and/or access to bikeways per the Bicycle Master Plan; construction of priority bikeways, on-site signage and bike lane striping.
  - Installation of safety elements per the Pedestrian Master Plan (such as crosswalk striping, curb ramps, count down signals, bulb outs, etc.) to encourage convenient and safe crossing at arterials, in addition to safety elements required to address safety impacts of the project.
  - Installation of amenities such as lighting, street trees, and trash receptacles per the Pedestrian Master Plan, the Master Street Tree List and Tree Planting Guidelines (which can be viewed at <http://www2.oaklandnet.com/oakca1/groups/pwa/documents/report/oak042662.pdf>)

***CONDITIONS OF APPROVAL***

and <http://www2.oaklandnet.com/oakca1/groups/pwa/documents/form/oak025595.pdf>, respectively)

and any applicable streetscape plan.

- Construction and development of transit stops/shelters, pedestrian access, way finding signage, and lighting around transit stops per transit agency plans or negotiated improvements.
- Direct on-site sales of transit passes purchased and sold at a bulk group rate (through programs such as AC Transit Easy Pass or a similar program through another transit agency).
- Provision of a transit subsidy to employees or residents, determined by the project applicant and subject to review by the City, if employees or residents use transit or commute by other alternative modes.
- Provision of an ongoing contribution to transit service to the area between the project and nearest mass transit station prioritized as follows: 1) Contribution to AC Transit bus service; 2) Contribution to an existing area shuttle service; and 3) Establishment of new shuttle service. The amount of contribution (for any of the above scenarios) would be based upon the cost of establishing new shuttle service (Scenario 3).
- Guaranteed ride home program for employees, either through 511.org or through separate program.
- Pre-tax commuter benefits (commuter checks) for employees.
- Free designated parking spaces for on-site car-sharing program (such as City Car Share, Zip Car, etc.) and/or car-share membership for employees or tenants.
- On-site carpooling and/or vanpool program that includes preferential (discounted or free) parking for carpools and vanpools.
- Distribution of information concerning alternative transportation options.
- Parking spaces sold/leased separately for residential units. Charge employees for parking, or provide a cash incentive or transit pass alternative to a free parking space in commercial properties.
- Parking management strategies including attendant/valet parking and shared parking spaces.
- Requiring tenants to provide opportunities and the ability to work off-site.
- Allow employees or residents to adjust their work schedule in order to complete the basic work requirement of five eight-hour workdays by adjusting their schedule to reduce vehicle trips to the worksite (e.g., working four, ten-hour days; allowing employees to work from home two days per week).
- Provide or require tenants to provide employees with staggered work hours involving a shift in the set work hours of all employees at the workplace or flexible work hours involving individually determined work hours.

The TDM Plan shall indicate the estimated VTR for each strategy, based on published research or guidelines where feasible. For TDM Plans containing ongoing operational VTR strategies, the Plan shall include an ongoing monitoring and enforcement program to ensure

the Plan is implemented on an ongoing basis during project operation. If an annual compliance report is required, as explained below, the TDM Plan shall also specify the topics to be addressed in the annual report.

When Required: Prior to approval of planning application.

Initial Approval: Bureau of Planning

Monitoring/Inspection: N/A

b. TDM Implementation – Physical Improvements

Requirement: For VTR strategies involving physical improvements, the project applicant shall obtain the necessary permits/approvals from the City and install the improvements prior to the completion of the project.

When Required: Prior to building permit final

Initial Approval: Bureau of Building

Monitoring/Inspection: Bureau of Building

c. TDM Implementation – Operational Strategies

Requirement: For projects that generate 100 or more net new a.m. or p.m. peak hour vehicle trips and contain ongoing operational VTR strategies, the project applicant shall submit an annual compliance report for the first five years following completion of the project (or completion of each phase for phased projects) for review and approval by the City. The annual report shall document the status and effectiveness of the TDM program, including the actual VTR achieved by the project during operation. If deemed necessary, the City may elect to have a peer review consultant, paid for by the project applicant, review the annual report. If timely reports are not submitted and/or the annual reports indicate that the project applicant has failed to implement the TDM Plan, the project will be considered in violation of the Conditions of Approval and the City may initiate enforcement action as provided for in these Conditions of Approval. The project shall not be considered in violation of this Condition if the TDM Plan is implemented but the VTR goal is not achieved.

When Required: Ongoing

Initial Approval: Department of Transportation

Monitoring/Inspection: Department of Transportation

**54. Transportation Impact Fee**

Requirement: The project applicant shall comply with the requirements of the City of Oakland Transportation Impact Fee Ordinance (chapter 15.74 of the Oakland Municipal Code).

When Required: Prior to issuance of building permit

Initial Approval: Bureau of Building

Monitoring/Inspection: N/A

**55. Plug-In Electric Vehicle (PEV) Charging Infrastructure**

*a. PEV-Ready Parking Spaces*

Requirement: The applicant shall submit, for review and approval of the Building Official and the Zoning Manager, plans that show the location of parking spaces equipped with full electrical circuits designated for future PEV charging (i.e. “PEV-Ready) per the requirements

of Chapter 15.04 of the Oakland Municipal Code. Building electrical plans shall indicate sufficient electrical capacity to supply the required PEV-Ready parking spaces.

When Required: Prior to Issuance of Building Permit

Initial Approval: Bureau of Building

Monitoring/Inspection: Bureau of Building

***b. PEV-Capable Parking Spaces***

Requirement: The applicant shall submit, for review and approval of the Building Official, plans that show the location of inaccessible conduit to supply PEV-capable parking spaces per the requirements of Chapter 15.04 of the Oakland Municipal Code. Building electrical plans shall indicate sufficient electrical capacity to supply the required PEV-capable parking spaces.

When Required: Prior to Issuance of Building Permit

Initial Approval: Bureau of Building

Monitoring/Inspection: Bureau of Building

***c. ADA-Accessible Spaces***

Requirement: The applicant shall submit, for review and approval of the Building Official, plans that show the location of future accessible EV parking spaces as required under Title 24 Chapter 11B Table 11B-228.3.2.1, and specify plans to construct all future accessible EV parking spaces with appropriate grade, vertical clearance, and accessible path of travel to allow installation of accessible EV charging station(s).

When Required: Prior to Issuance of Building Permit

Initial Approval: Bureau of Building

Monitoring/Inspection: Bureau of Building

**UTILITY AND SERVICE SYSTEMS**

**56. Construction and Demolition Waste Reduction and Recycling**

Requirement: The project applicant shall comply with the City of Oakland Construction and Demolition Waste Reduction and Recycling Ordinance (chapter 15.34 of the Oakland Municipal Code) by submitting a Construction and Demolition Waste Reduction and Recycling Plan (WRRP) for City review and approval, and shall implement the approved WRRP. Projects subject to these requirements include all new construction, renovations/alterations/modifications with construction values of \$50,000 or more (except R-3 type construction), and all demolition (including soft demolition) except demolition of type R-3 construction. The WRRP must specify the methods by which the project will divert construction and demolition debris waste from landfill disposal in accordance with current City requirements. The WRRP may be submitted electronically at [www.greenhalosystems.com](http://www.greenhalosystems.com) or manually at the City’s Green Building Resource Center. Current standards, FAQs, and forms are available on the City’s website and in the Green Building Resource Center.

When Required: Prior to approval of construction-related permit

Initial Approval: Public Works Department, Environmental Services Division

Monitoring/Inspection: Public Works Department, Environmental Services Division

**57. Underground Utilities**

Requirement: The project applicant shall place underground all new utilities serving the project and under the control of the project applicant and the City, including all new gas, electric, cable, and telephone facilities, fire alarm conduits, street light wiring, and other wiring, conduits, and similar facilities. The new facilities shall be placed underground along the project's street frontage and from the project structures to the point of service. Utilities under the control of other agencies, such as PG&E, shall be placed underground if feasible. All utilities shall be installed in accordance with standard specifications of the serving utilities.

When Required: During construction

Initial Approval: N/A

Monitoring/Inspection: Bureau of Building

**58. Recycling Collection and Storage Space**

Requirement: The project applicant shall comply with the City of Oakland Recycling Space Allocation Ordinance (chapter 17.118 of the Oakland Planning Code). The project drawings submitted for construction-related permits shall contain recycling collection and storage areas in compliance with the Ordinance. For residential projects, at least two (2) cubic feet of storage and collection space per residential unit is required, with a minimum of ten (10) cubic feet. For nonresidential projects, at least two (2) cubic feet of storage and collection space per 1,000 square feet of building floor area is required, with a minimum of ten (10) cubic feet.

When Required: Prior to approval of construction-related permit

Initial Approval: Bureau of Planning

Monitoring/Inspection: Bureau of Building

**59. Green Building Requirements**

***a. Compliance with Green Building Requirements During Plan-Check***

Requirement: The project applicant shall comply with the requirements of the California Green Building Standards (CALGreen) mandatory measures and the applicable requirements of the City of Oakland Green Building Ordinance (chapter 18.02 of the Oakland Municipal Code).

- i. The following information shall be submitted to the City for review and approval with the application for a building permit:
  - Documentation showing compliance with Title 24 of the current version of the California Building Energy Efficiency Standards.
  - Completed copy of the final green building checklist approved during the review of the Planning and Zoning permit.
  - Copy of the Unreasonable Hardship Exemption, if granted, during the review of the Planning and Zoning permit.



- Permit plans that show, in general notes, detailed design drawings, and specifications as necessary, compliance with the items listed in subsection (ii) below.
  - Copy of the signed statement by the Green Building Certifier approved during the review of the Planning and Zoning permit that the project complied with the requirements of the Green Building Ordinance.
  - Signed statement by the Green Building Certifier that the project still complies with the requirements of the Green Building Ordinance, unless an Unreasonable Hardship Exemption was granted during the review of the Planning and Zoning permit.
  - Other documentation as deemed necessary by the City to demonstrate compliance with the Green Building Ordinance.
- ii. The set of plans in subsection (i) shall demonstrate compliance with the following:
- CALGreen mandatory measures.
  - Green building point level/certification requirement per the appropriate checklist approved during the Planning entitlement process.
  - All green building points identified on the checklist approved during review of the Planning and Zoning permit, unless a Request for Revision Plan-check application is submitted and approved by the Bureau of Planning that shows the previously approved points that will be eliminated or substituted.
  - The required green building point minimums in the appropriate credit categories.

When Required: Prior to approval of construction-related permit

Initial Approval: Bureau of Building

Monitoring/Inspection: N/A

***b. Compliance with Green Building Requirements During Construction***

Requirement: The project applicant shall comply with the applicable requirements of CALGreen and the Oakland Green Building Ordinance during construction of the project.

The following information shall be submitted to the City for review and approval:

- i. Completed copies of the green building checklists approved during the review of the Planning and Zoning permit and during the review of the building permit.
- ii. Signed statement(s) by the Green Building Certifier during all relevant phases of construction that the project complies with the requirements of the Green Building Ordinance.
- iii. Other documentation as deemed necessary by the City to demonstrate compliance with the Green Building Ordinance.

When Required: During construction

Initial Approval: N/A

Monitoring/Inspection: Bureau of Building

***c. Compliance with Green Building Requirements After Construction***

Requirement: Prior to the finaling the Building Permit, the Green Building Certifier shall submit the appropriate documentation to City staff and attain the minimum required point level.

When Required: Prior to Final Approval

Initial Approval: Bureau of Planning

Monitoring/Inspection: Bureau of Building

**60. Sanitary Sewer System**

Requirement: The project applicant shall prepare and submit a Sanitary Sewer Impact Analysis to the City for review and approval in accordance with the City of Oakland Sanitary Sewer Design Guidelines. The Impact Analysis shall include an estimate of pre-project and post-project wastewater flow from the project site. In the event that the Impact Analysis indicates that the net increase in project wastewater flow exceeds City-projected increases in wastewater flow in the sanitary sewer system, the project applicant shall pay the Sanitary Sewer Impact Fee in accordance with the City's Master Fee Schedule for funding improvements to the sanitary sewer system.

When Required: Prior to approval of construction-related permit

Initial Approval: Public Works Department, Department of Engineering and Construction

Monitoring/Inspection: N/A

**61. Storm Drain System**

Requirement: The project storm drainage system shall be designed in accordance with the City of Oakland's Storm Drainage Design Guidelines. To the maximum extent practicable, peak stormwater runoff from the project site shall be reduced by at least 25 percent compared to the pre-project condition.

When Required: Prior to approval of construction-related permit

Initial Approval: Bureau of Building

Monitoring/Inspection: Bureau of Building

**62. Water Efficient Landscape Ordinance (WELO)**

Requirement: The project applicant shall comply with California's Water Efficient Landscape Ordinance (WELO) in order to reduce landscape water usage. For any landscape project with an aggregate (total noncontiguous) landscape area equal to 2,500 sq. ft. or less. The project applicant may implement either the Prescriptive Measures or the Performance Measures, of, and in accordance with the California's Model Water Efficient Landscape Ordinance. For any landscape project with an aggregate (total noncontiguous) landscape area over 2,500 sq. ft., the project applicant shall implement the Performance Measures in accordance with the WELO.

*Prescriptive Measures:* Prior to construction, the project applicant shall submit documentation showing compliance with Appendix D of California's Model Water Efficient Landscape Ordinance (see website below starting on page 23):

<http://www.water.ca.gov/wateruseefficiency/landscapeordinance/docs/Title%202023%20extract%20-%20Official%20CCR%20pages.pdf>

*Performance Measures:* Prior to construction, the project applicant shall prepare and submit a Landscape Documentation Package for review and approval, which includes the following

---

- a. Project Information:
  - i. Date,
  - ii. Applicant and property owner name,
  - iii. Project address,
  - iv. Total landscape area,
  - v. Project type (new, rehabilitated, cemetery, or home owner installed),
  - vi. Water supply type and water purveyor,
  - vii. Checklist of documents in the package, and
  - viii. Applicant signature and date with the statement: "I agree to comply with the requirements of the water efficient landscape ordinance and submit a complete Landscape Documentation Package."
- b. Water Efficient Landscape Worksheet
  - i. Hydrozone Information Table
  - ii. Water Budget Calculations with Maximum Applied Water Allowance (MAWA) and Estimated Total Water Use
- c. Soil Management Report
- d. Landscape Design Plan
- e. Irrigation Design Plan, and
- f. Grading Plan

Upon installation of the landscaping and irrigation systems, the Project applicant shall submit a Certificate of Completion and landscape and irrigation maintenance schedule for review and approval by the City. The Certificate of Compliance shall also be submitted to the local water purveyor and property owner or his or her designee.

For the specific requirements within the Water Efficient Landscape Worksheet, Soil Management Report, Landscape Design Plan, Irrigation Design Plan and Grading Plan, see the link below.

<http://www.water.ca.gov/wateruseefficiency/landscapeordinance/docs/Title%202023%20extract%20-%20Official%20CCR%20pages.pdf>

When Required: Prior to approval of construction-related permit

Initial Approval: Bureau of Planning

Monitoring/Inspection: Bureau of Building

## **Part 3: Standard Conditions of Approval – Other Standard Conditions**

---

### **63. Employee Rights**

Requirement: The project applicant and business owners in the project shall comply with all state and federal laws regarding employees' right to organize and bargain collectively with employers and shall comply with the City of Oakland Minimum Wage Ordinance (chapter 5.92 of the Oakland Municipal Code).

When Required: Ongoing

Initial Approval: N/A

Monitoring/Inspection: N/A

### **64. Neighborhood Retail Survey**

Requirement: The project applicant shall conduct a survey of community members located within one-half mile of the project site to identify neighborhood needs and preferences for the proposed commercial space. The City strongly encourages the project applicant to seek tenants for the proposed commercial space that meet the needs and preferences of local community members. Please refer to the City's Survey Guidelines for more information (contained in a separate document and available from the Oakland Planning Bureau).

When Required: Prior to commercial operations

Initial Approval: N/A

Monitoring/Inspection: N/A

### **65. High-Quality Design of Ground-Floor Public Plazas and Walkways.**

Requirement: In order to ensure a safe and lively pedestrian realm around the BART station and the proposed project, the ground floor public plazas and walkways shall be high-quality, well-designed spaces that include excellent pedestrian-scaled lighting, extensive furnishings, and interactive art or other amenities for children.

When Required: FDP for horizontal improvements and PX/PZ Permit.

Initial Approval: Bureau of Planning

Monitoring/Inspection: Bureau of Building

### **66. Programming of Ground-Floor Public Plazas.**

Requirement: Provide regular programming of the plaza on 7<sup>th</sup> St, including concerts, farmer's markets, local vendor pop-ups, etc. These events shall be regularly scheduled events with a calendar that can be used to advertise at BART stations and throughout the community. Applicant shall provide Bureau of Planning staff with an event program and evidence of program manager retention on an annual basis. The event program shall include a minimum of twenty-four (24) events per year, each event to last a minimum of three hours. The event program should

state the name and contact information for the program manager, the date, time, name and nature of each event.

When Required: Completion of public plaza construction-related permits

Initial Approval: Bureau of Planning

Monitoring/Inspection: Bureau of Building

**67. High-Quality and High-Amenity Residential Group Open Space.**

Requirement: The project applicant is only providing ~~28%~~50% of the required useable open space for residential development, so the open space that is provided shall be high-quality and high-amenity. Group open space shall include amenities that are attractive to families with children as well as single residents such as high quality fire pits, bbq areas, pools, or hot tubs, and ample high quality play equipment for various age groups.

When Required: Prior to approval of FDP for each vertical phase of development.

Initial Approval: Bureau of Planning

Monitoring/Inspection: Bureau of Building

**68. Retail on 7<sup>th</sup> Street Plaza Design Under the BART Tracks.**

Requirement: ~~The project applicant shall provide approximately 7,610 square feet of retail under the BART tracks between Chester Street and the BART Station, consistent with the approved PDP. If retail uses under the BART tracks are deemed infeasible by the City of Oakland, then an equivalent amount of retail shall be provided along 7<sup>th</sup> St between Chester Street and Center Street. Retail can be provided in kiosks, containers, or other small scale retail buildings. At the same time, if retail cannot be provided under the BART tracks on Development Area T2, then~~ The applicant shall design the space under the BART tracks in development area T2 as an attractive, delightful space for residents, community members, and BART riders to spend time with adequate provisions for safety such as security and lighting improvements.

When Required: Prior to approval of FDP ~~that includes retail on Development Area T2~~ for Horizontal Improvements.

Initial Approval: Bureau of Planning

Monitoring/Inspection: Bureau of Building

**69. Provide noise buffering of BART tracks.**

Requirement: Consistent with the requirements of the WOSP, the proposed buildings adjacent to the BART tracks shall be designed to buffer and attenuate noise from BART to the surrounding neighborhood. New buildings shall not aggravate noise conditions for the surrounding community, and where feasible shall mitigate BART noise in compliance with the WOSP.

When Required: Prior to approval of building permit.

Initial Approval: Bureau of Building, Bureau of Planning

Monitoring/Inspection: Bureau of Building

**70. Project Phasing**

The project phasing is as follows:

Phase I (submitted within 24 years of approved PDP)

- a) FDP for all horizontal and off-site improvements and infrastructure (submitted within two years ~~one year~~ after the approval of PDP), including but not limited to the following improvements:
  - i. Final design for all public plazas and walkways
  - ii. Final design for streetscape improvements
  - iii. Detailed phasing plan for implementation of all horizontal improvements, ensuring continuous AC Transit service, access to the BART station, and adequate emergency access throughout all phases, to the satisfaction of the City of Oakland, BART, and AC Transit.

~~PX/PZ Permit for horizontal improvements and infrastructure, with phasing (to be approved prior to issuance of any building permit)~~
- b) FDP for Residential/Retail (Development Area ~~T2 and T3~~) (submitted within two years after the approval of the PDP):
  - i. 240 multifamily housing units ~~and 22 duplex residential units~~ (Development Area T3);
  - ii. ~~15,200~~944 square feet of retail along 5<sup>th</sup> St (Development Area T3);  
~~7,670 square feet of retail under the BART tracks (Development Area T2)~~
  - iii. ~~272~~ 50 parking spaces (Development Area T3); and
  - iv. ~~60,224~~ 24,815 square feet of open space (in private and group configurations).
- c) PX/PZ Permit complete application for horizontal improvements and infrastructure related to Phase I submitted within 2 years of the FDP approval and diligently pursued towards completion. The PX/PZ for Phase I horizontal improvements shall be approved prior to issuance of any building permit. Bonding is required for all future phases of public improvements that are not included in Phase I.
- d) Building Permits for Development Areas ~~T2 and T3~~, including grading permit (complete building permit application filed with the Bureau of Building within two years of approval of FDP and diligently pursued towards approval).
  - i. Building permits for Development Areas ~~T2 and T3~~ will not be granted until the PX/PZ Permit is approved

Any other improvements or changes thereto that the City deems necessary to conform to project approvals and plans.

Phase II (submitted and application deemed complete within two years of Phase I FDP approval). Phase II can occur concurrently with Phase I, as long as all requirements of Condition #78 related to Affordable Residential Rental Units - Agreement and Monitoring are met.

- a) FDP for residential Tower with ~~office and~~ retail (Development Area T1):
  - i. ~~522~~00 dwelling units;
  - ii. ~~82,460 square feet of office~~
  - iii. ~~14,350,185~~ square feet of retail;
  - iv. ~~17,6488,002~~ square feet of group open space (in private and group configurations),  
and
  - v. 125 parking spaces
  - vi. ~~600 space bike station with retail under the tracks (between Development Areas T1 and T4)~~

- b) PX/PZ Permit for horizontal improvements and infrastructure related to Phase II (to be approved prior to issuance of any building permit).
- c) Building Permits for Development Area T1 (complete building permit application filed with the Bureau of Building within two years after approval of FDP and diligently pursued towards approval).
- d) Under track bike station (between Development Areas T1 and T4) to be permitted by BART, with review by City of Oakland, should be completed as part of Phase II.

Any other improvements or changes that the City deems necessary to conform to project approvals and plans.

Phase III (submitted and application deemed complete within two years of Phase II FDP)

- a) FDP for office and retail (Development Area T4): (submitted and application deemed complete within two years of Phase II FDP approval)
  - i. 300,000 square feet of office;
  - ii. ~~30,800~~ 23,184 square feet of retail; and
  - iii. ~~428~~ 210 parking spaces.
- b) PX/PZ Permit for horizontal improvements and infrastructure related to Phase III (to be approved prior to issuance of any building permit for Phase III).
- c) Building Permits for Development Area T4 (complete building permit application filed with the Bureau of Building within two years after approval of Phase III FDP and diligently pursued towards approval)

Any other improvements or changes thereto that the City deems necessary to conform to project approvals and plans.

When Required: Each FDP.

Initial Approval: Bureau of Planning

Monitoring/Inspection: N/A

**71. Submittal and Approval of FDP for Horizontal Improvements.**

Multiple FDPs may be submitted as a part of the project, but the FDP for Horizontal Improvements shall be submitted before, or in conjunction with, any other FDP.

Requirement: The project applicant shall apply for the Final Development Permit (FDP) for all horizontal improvements before any other FDPs shall be considered. The FDP for horizontal improvements shall be approved before, or in conjunction with, any other FDP approval. In any event, the horizontal improvements required in Phase I should be developed prior to any other improvements in any other Phase. The FDP for horizontal improvements shall include a phasing plan for implementation of all horizontal improvements, ensuring uninterrupted AC Transit service and provision of adequate emergency vehicle access, to the satisfaction of AC Transit, the City of Oakland, and BART. Horizontal improvements include, but are not limited to: public plazas, public walkways, sidewalks improvements, bikeways, crosswalks, curb extensions, bus stops, intersection improvements, etc.

When Required: Prior to submittal or approval of any other FDP.

Initial Approval: Bureau of Planning

Monitoring/Inspection: N/A

**72. Submittal and Approval of PX/PZ permit for horizontal improvements.**

Requirement: The project applicant shall apply for the PX/PZ permit for all horizontal improvements and receive approval from all relevant departments and agencies before any building permits will be approved. Horizontal improvements include, but are not limited to: public plazas, public walkways, sidewalks improvements, bikeways, crosswalks, curb extensions, bus stops, intersection improvements, etc. If the applicant requests to implement the public improvements in phases, the PX/PZ permits shall be submitted consistent with the desired phases, but at the first phase, the applicant shall bond for all public improvements that will be implemented in future phases. In addition, the following phasing criteria shall be met:

- All improvements on both sides of 7<sup>th</sup> Street, including sidewalks, loading areas, intersection improvements, and the Class IV cycle track continuation on Mandela Parkway to 5<sup>th</sup> Street, shall be operational and functional prior to the issuance of the Certificate of Occupancy for the residential tower on T1. The Blues Walk of Fame plaques shall be reinstalled along 7<sup>th</sup> St as a part of this phase of work.
- All off-site improvements, as articulated in Condition #52, shall be operational prior to the issuance of the Certificate of Occupancy for the residential tower on T1, unless otherwise articulated in the condition.

When Required: Prior to approval of any building permit.

Initial Approval: Bureau of Building and OakDOT

Monitoring/Inspection: N/A

**73. Compliance with all relevant Conditions of Approval.**

Requirements: In addition to the conditions above, project applicant shall comply with the conditions in the attached exhibits, including:

- Exhibit A: City of Oakland Department of Transportation, Engineering Services Conditions of Approval
- Exhibit B: City of Oakland Department of Transportation, Office of the City Surveyor Conditions of Approval
- Exhibit C: City of Oakland Fire Department, Conditions of Approval

When Required: As specified in the specific conditions of approval

Initial Approval: As specified in the specific conditions of approval

Monitoring/Inspection: As specified in the specific conditions of approval

**74. Below market rate retail**

Requirements: If feasible, a minimum of 20% of the total retail square footage or number of tenants shall be provided below market rate.

When Required: At time of close out of building permit for each phase of development.



Initial Approval: Bureau of Planning.

Monitoring/Inspection: NA.

**75. Level of affordable housing provided**

Requirements: Provide one third (1/3) of all affordable residential units below 30% Area Median Income (AMI)

When Required: At FDP and building permits for Phase I development (Development Area T3)

Initial Approval: Bureau of Planning

Monitoring/Inspection: NA

**76. Performance Bonds.**

Requirements: Pursuant to O.M.C. Section 17.97.035, a cash bond or surety bond for the completion of all of the public improvements that facilitate public access to the BART station, including, but not limited to, sidewalks, bike lanes intersection improvements, etc shall be required for those improvements for which a building permit is not submitted within two years of FDP approval. The bond shall be in a form approved by the City Attorney, in a sum of one hundred fifty percent (150%) of the estimated cost of the work, and conditioned upon the faithful performance of the work specified within the time specified, according to the Phasing Plan.

When Required: At first PX Permit

Initial Approval: Bureau of Planning and OakDOT

Monitoring/Inspection: OakDOT

**77. Rotating Art Exhibit Wall on Development Area T3**

Requirements: A rotating art exhibit shall be provided on the T3 wall facing the BART tracks, consistent with the PDP. The applicant intends to use portions of the Public Art fee to pay for the infrastructure for the rotating art. At the time of building permit application, applicant shall provide details for the rotating art exhibit wall, for City (Staff and Public Art Advisory Committee) approval, in accordance with O.M.C. Section 15.78.070.C.3, Alternative Means of Satisfaction of Public Art Requirement, including:

- Management plan, including who will curate and manage the rotating art
- Contractual agreements to support the management plan
- Budget, schedule and funding plan for implementation of rotating art
- Conceptual Art Plan and Details of first ‘exhibit’, including chosen artist(s) and associated agreements in accordance with the City’s Public Art Supplemental Submittal requirements
- Documentation of Preliminary BART art requirements and restrictions

The first exhibit of the rotating art exhibit wall shall be installed prior to Issuance of a Certificate of Occupancy for T3/Phase 1. The rotating art exhibit wall shall not be without art for more than 30 days.

Prior to Issuance of the Building Permit for T3, if the rotating art exhibit is deemed infeasible by City staff, an alternate permanent Public Art proposal for this wall shall be submitted for approval in its place. The permanent wall art shall follow the conditions related to providing Public Art for Private Development, including providing for plans showing fulfillment of public art requirement. Installation of the art shall be provided prior to issuance of a Certificate of Occupancy.

If the permanent Public Art is also deemed infeasible, then prior to Issuance of the Building Permit, the project shall go back to the Design Review Committee for review to ensure the wall has appropriate architectural detail and interest to be a stand-alone wall without art.

When Required: Submittal of Final Public Art Plan at Building Permit Application. City approval of plans providing details of the rotating art exhibit wall Public Art Submittal plan, including who will manage the exhibits, associated contracts, financial plan for ongoing exhibits, and plan for first exhibit – Prior to Issuance of Building permit

Installation of art/cultural space – Prior to Issuance of a Certificate of Occupancy.

Initial Approval: Economic & Workforce Development/Public Art Program and Public Art Advisory Committee (approval by PAAC for this alternative plan required in OMC) and Bureau of Planning

Monitoring/Inspection: Economic & Workforce Development/ Public Art Program and Bureau of Building

## **78. Affordable Residential Rental Units - Agreement and Monitoring**

Requirement #1: Pursuant to Section 17.107 of the Oakland Planning Code and the State Density Bonus Law California Government Code Section 65915 et seq. (“**State Density Bonus Law**”), the proposed project shall provide a minimum of 90 target dwelling units available at very low income (as 15% of the units), 148 target dwelling units available at low income (60% AMI), and 2 units at 120% AMI, for a total of 240 affordable units. This meets, and in fact exceeds, the minimum requirements for receiving a density bonus, concession and/or waiver of development standards.

Requirement #2: The approved residential affordable units that are part of this approval shall remain and continue to be affordable at the specified level in accordance with California Health and Safety Code Section 50053 and its implementing regulations for a term of not less than 55 years or a longer period of time if required by the construction or mortgage finance assistance program, mortgage insurance program, or rental subsidy program. This Condition of Approval must also be in compliance with Section 65915(c)(1) of the State Density Bonus Law specifically, as well as all other applicable provisions of the State Density Bonus Law.

Requirement #3: **Prior to submittal of a construction-related permit**, the applicant shall contact the the Housing and Community Development Department (Housing Development Services Division) to enter into a Regulatory Agreement based on the City’s model documents, as may be amended from time to time, governing the target dwelling units. The Agreement shall contain restrictive covenants to ensure the continued affordability of the target dwelling units at the specified rent levels for a period of not less than fifty-five (55) years pursuant Section 65915 (c)(1) of the State Density Bonus Law, and restrict the occupancy of those units only to residents who satisfy the affordability requirement as

approved for this project. Only households meeting the eligibility standards for the target dwelling units shall be eligible to occupy the target dwelling units.

If the property has an approved condominium map and the developer chooses to rent the affordable units at initial occupancy, the units cannot convert to ownership during the term of the Agreement, even if the market rate units in the development convert to ownership.

The Regulatory Agreement shall be recorded with the Alameda County Recorder's Office as an encumbrance against the property, and a copy of the recorded agreement shall be provided to and retained by the City. **The Regulatory Agreement may not be subordinated in priority to any other lien interest in the property.**

Requirement #4: Rental target dwelling units shall be managed / operated by the developer or developer's agent or the developer's successor. The developer of rental target dwelling units shall submit for review and approval by the Housing and Community Development Department and any other relevant City departments, an annual report identifying which units are target dwelling units, the monthly rent, vacancy information, monthly income for tenants of each target rental dwelling unit throughout the prior year, and other information required by the City. Said agreement shall maintain the tenants' privacy. The applicant shall pay to the Housing and Community Development Department an annual monitoring fee pursuant to the Master Fee Schedule (updated annually and available from the Budget Office of the City Oakland's Finance Department: <https://www.oaklandca.gov/departments/finance-department>) for City monitoring of target dwelling units .

Requirement #5: The floor area, number of bedrooms, and amenities (such as fixtures, appliances, location and utilities) of the affordable units shall be substantially equal in size and quality to those of the market rate units. Further, the proportion of unit types (i.e. three-bedroom and four-bedroom, etc.) of the affordable units shall be roughly the same as the project's market rate units.

Requirement #6: Tenant households in affordable units must have equal access to the project's services and facilities as tenant households in all other units within the project.

Requirement #7: Applicant shall comply with the requirements of Section 65915(c)(3)(A) of the State Density Bonus Law requiring, without limitation, replacement units in those circumstances where the parcel subject to the density bonus requests contains or contained affordable units within the last five years.

Requirement #8: Applicants shall comply with all applicable provisions of State Density Bonus Law and all provisions of the City's density bonus law that are not preempted by state law.

Requirement #9: Affordable units shall be constructed concurrent with the construction of the market rate units in each phase of the project.

Requirement #10: The City will not issue final certificates of occupancy for more than fifty percent (50%) of the market rate units in any phase of development until final certificates of occupancy are issued for all of the affordable units in that phase.

When Required: First Construction-Related Permit Application and Ongoing Initial Approval: Housing and Community Development Department – Housing Development Services Division  
Ongoing Monitoring/Inspections: Housing Development Services Division

**Applicant Statement**

I have read and accept responsibility for the Conditions of Approval. I agree to abide by and conform to the Conditions of Approval, as well as to all provisions of the Oakland Planning Code and Oakland Municipal Code pertaining to the project.

\_\_\_\_\_  
Name of Project Applicant

\_\_\_\_\_  
Signature of Project Applicant

\_\_\_\_\_  
Date

## **Exhibit 2:**

### **Conditions of Approval**

- Oakland Department of Transportation, Engineering Services Conditions of Approval

# City of Oakland Department of Transportation

Transportation and Right-of-Way Management Division, Engineering Services

If Project is approved by the Advisory Agency, attach the Engineering Services "Conditions of Approval" provided below.

<b>Planning/Zoning Number(s)</b> PLN18490-REV02, PLN18521-R01		<b>Engineering Staff Contact</b> Chong Hong	
<b>Project Address</b> 1451 7th Street		<b>Project Description</b> Merger & subdivide into 3 condominium parcels & 1 reminder parcel	
<b>Tentative Map No.</b> VTPM10940	No. of New Lots	<b>4</b>	No. Condominiums 4 on each lot <input type="checkbox"/> Mixed Use
<input type="checkbox"/> <b>No Map</b>	<input type="checkbox"/> <b>Parcel Map Waiver</b>	<input checked="" type="checkbox"/> <b>Merger</b>	<input type="checkbox"/> <b>Lot Line Adjustment LLA</b> <input type="checkbox"/> <b>No. Existing Lots LLA</b> <input type="checkbox"/> <b>No. New Lots LLA</b>
<b><u>GENERAL REQUIREMENTS</u></b>		<b><u>SPECIFIC PROJECT CONDITIONS OF APPROVAL</u></b>	
<u>SIDEWALKS, CURB AND GUTTERS</u> 1. Existing sidewalks fronting subject property must be compliant with ADA standards. 2. Uplifted, uneven, damaged sidewalks shall be repaired with no more than ¼ inch lift and no more than 2% cross slope. 3. Sidewalk clear width of 5.5 feet minimum is required and must not be less than 50-inches between obstacles, poles, trees, hydrants, pinch points for ADA access. 4. Existing sidewalks, curbs/gutter/driveway approaches damaged, broken or if non-standard shall be repaired. 5. A Curb, Gutter and Sidewalk (CGS) permit is required to repair or construct sidewalk. 6. Infrastructure and improvements to be privately maintained within the right of way and any non-standard features MAY be accepted with an Encroachment Permit. 7. City may revoke encroachment permit at its sole discretion and may charge property owner(s) for use of the right-of-way.		Prior to issuance of a building permit for any phase in the project or recording of Parcel Map, applicant shall obtain a PX permit and enter into a P-Job Agreement for construction of improvements within the City's right-of-way and post bond of the entire offsite improvements. Improvement plans shall be prepared by a registered civil engineer and submitted to Department of Transportation, Engineering Services for review and approval prior to issuance of a PX permit. Applicants shall obtain permit from Department of Transportation prior to beginning construction within the right-of-way.  Applicant shall post bond for the entire public improvements in the 1st phase PX permit.	
<u>STREET PAVING AND STRIPING</u> 8. Street and roadway area(s) fronting the development must be resurfaced up to one traffic lane in width 13 ft. or to the centerline of the street, after completion of construction and as required by the Inspector. 9. Evaluation of the street's Pavement Condition Index at time plans are submitted for permit review shall determine any restoration requirements. 10. Existing striping fronting the property and up to 1 block length shall be restored to the satisfaction of the Inspector. Thermoplastic shall be required unless specified otherwise in the plans approved for construction. 11. "Moratorium Streets" are resurfaced or newly constructed streets within the past 5-year period. No trenching or excavation is permitted on any Moratorium Street without the written authorization of the Public Works Director.		Conditions 8, 9, 10 and 11 apply.  Actual limit of pavement restorations will be determined based on the project affected street Pavement Condition Index.  Engineering Services will determine if any of the improvements shown on the plans submitted for the PX permit require the review and approval of the City's Traffic Engineer prior to issuance of the PX permit.	
<u>DRIVEWAYS</u> 12. Driveway approach, length, width, driveway separation, clearances from poles and utilities, type of curb, driveway angle, shall be approved by Bureau of Planning in advance of any review by Engineering Services. 13. Any existing driveway that will no longer be required to serve the property shall be replaced with new sidewalk curb and gutter, with curb striping as required by Inspector.		Driveway approaches shall be identified on the improvement plans for the PX permit and proposed locations must be approved by Engineering Services and Planning Department.	
<u>CURB RAMPS</u> 14. New curb ramps shall meet the latest State of California standards when plans are submitted for review.		See comments on Page 2.	

<p>15. Curb ramps shall be directional unless approved otherwise in writing by the City Engineer.</p> <p>16. New curb ramps are required at intersections fronting the project site and when the use or occupancy necessitates installation or replacement of curb ramps. Additional curb ramps required by the City Engineer shall be installed by the project sponsor.</p> <p>17. Where a new curb ramp is required for the project the curb ramp located on the opposite side of the roadway, across a marked or un-marked crosswalk, shall also be installed or upgraded to be ADA compliant by the project sponsor.</p>	<p>New directional handicap ramps shall be installed at the intersection(s) fronting the property and directly across each intersection to the satisfaction of the City Engineer. The improvement plans submitted for the PX permit shall identify all handicap ramps to be installed.</p>
<p><b><u>STREET GEOMETRY AND STRIPING DESIGN</u></b></p> <p>18. New striping, curb painting, bulb-outs, changes to existing dimensions, impact to traffic resulting from development, traffic pattern, circulation, signals, traffic count, street/lane change shall be reviewed and approved by the City’s Traffic Engineer.</p> <p>19. Any alteration to geometry of roadway/sidewalk, markings, traffic control signs and devices shall be reviewed and approved by the City’s Traffic Engineer.</p> <p>20. Traffic and parking sign posts shall be coated with anti-graffiti coating.</p> <p>21. Traffic Control Plans (TCP) for temporary traffic control measures shall be submitted separately for review and approval by City’s Traffic Engineer prior to permit issuance and when the TCP is adjusted and updated during construction.</p>	<p>Engineering Services will determine if any of the improvements shown on the plans submitted for the PX permit require the review and approval of the City’s Traffic Engineer prior to issuance of the PX permit.</p>
<p><b><u>SANITARY SEWER</u></b></p> <p>22. Sanitary sewer impact analysis is required when new development results in a net increase of volume of wastewater flow to the City’s sanitary sewer system. Sewer flow calculations prepared by developer’s engineer must include existing and proposed flows. Developer shall submit analysis with completed application for review. Mitigation fees shall be paid prior to issuance of a Building or PX permit whichever occurs first.</p> <p>23. A “PSL” certificate, Sewer Lateral Permit, and EBMUD Inspection are required for all projects where construction costs are one-hundred thousand dollars (\$100K +) or more.</p> <p>24. A Sewer Lateral permit (SL) is required for any new sewer lateral or rehabilitation of existing lateral. Abandonment of a sewer lateral requires a separate permit.</p> <p>25. Sewer profiles shall be included on the plans approved for construction. If existing utilities are within twelve inches (12”) of proposed sewer, engineer shall have existing utility potholed and resolve conflict before approval of plans.</p>	<p>Condition 22, 23, 24, and 25 apply.</p> <p>Applicant shall submit sewer calculations and design for review and approval at the time of submitting improvement plans for PX permit. Applicant shall obtain PSL certificate, a SL permit and lateral abandonment permit(s) as applicable to the proposed development.</p> <p>Sewer mitigation fee must be paid in full before PX permit issuance. Applicant is responsible for existing sewer main upgrade associated with the project.</p> <p>See addition information note 2 in Page 5.</p>
<p><b><u>STORM DRAINS</u></b></p> <p>26. Connection of storm drain to sewer line is prohibited. Any unauthorized connection shall be separated from the sanitary sewer.</p> <p>27. Drainage plans shall be submitted for review and approval. Plans shall follow City standard details and design standards. Blind connections or tap connections are prohibited for storm drains.</p>	<p>Applicant shall submit the storm drainage calculations for review and approval at the time of submitting the improvement plans for PX permit. No runoff shall cross private property lines without first recording a storm drainage easement for this purpose. New storm drainage easements on private property shall be privately maintained and will not be accepted by the City.</p>

<p>28. Hydrology and Hydraulic Calculations, shall meet City’s Storm Drainage Design Standards.</p> <p>29. Reduction in Peak Flow by 25% or to the extent possible is required.</p>	
<p><u>STORM WATER TREATMENT</u></p> <p>30. Requirements for permanent and temporary storm water pollution prevention, Alameda County Clean Water Program (C.3), shall be included in the Building improvement plans for on-site work. Any approved storm drain from on-site development shall be tied to an inlet structure at the back of curb designating public and private ownership.</p> <p>31. Permanent storm water treatment (BMP’s) to service the development shall be privately maintained and included in the O&amp;M Agreement for the project.</p> <p>32. Roof runoff must be directed through an approved treatment device prior to entering the City’s storm drainage system.</p> <p>33. Right-of-way shall not be used for storm water treatment features.</p>	<p>Applicant shall submit the storm drainage calculations for review and approval at the time of submitting the improvement plans for PX permit.</p>
<p><u>STREET TREES AND LANDSCAPING (PRIVATE)</u></p> <p>34. Trees and irrigation for the proposed development shall be owned and maintained by the property owner(s).</p> <p>35. Landscape and irrigation plans shall be submitted with the civil plans for work (PX permit) for review and approval by the City’s Arborist.</p> <p>36. Landscape, irrigation plans and tree species shall meet City standards for Street Tree Planting.</p> <p>37. Tree shall be spaced twenty feet (20’) on center and shall not obstruct street lights. Tree wells shall be 3 ft. x 3ft. or 4 ft. x 4 ft. (minimum) for mature tree height of 25 to 40 feet.</p> <p>38. Tree Grates, Root Barrier and Staking Details for new trees shall be included in the approved plans. Tree Grates must be ADA compliant.</p>	<p>The improvement plans submitted for the PX permit shall include landscape and irrigation plans for any landscaping proposed with the City’s right-of-way. Any street trees, tree grates and root barriers shall be reviewed and approved by the City’s Arborist as determined by Engineering Services.</p>
<p><u>EASEMENTS AND ENCROACHMENTS</u></p> <p>39. All property lines, existing and proposed easements, shall be clearly shown on the plans for construction (PX permit).</p> <p>40. Easement dedication or vacation requires separate application and permit (PPE permit) if not included on a Final Tract Map or Parcel Map.</p> <p>41. Major Encroachment permits require City Council resolution and Indenture Agreement with County Recorder’s Number shown on the Final or Parcel Map.</p> <p>42. Permanent building elements encroaching into the right-of-way normally require a Major Encroachment (ENMJ permit)_Other approved encroachments may be part of Minor Encroachment (ENMI permit).</p> <p>43. City may revoke encroachment permit at its sole discretion and may charge property owner(s) for use of the right-of-way.</p>	<p>All emergency access and utility easements for the proposed development shall be clearly identified on the improvement plans submitted for the PX permit. The applicant shall apply for and obtain any necessary encroachment permits prior to issuance of a PX permit. If a major encroachment permit for the proposed building is required, the applicant shall submit to Engineering Services for review and approval all necessary plans and exhibits for the City Council resolution and the recorded major encroachment permit.</p>
<p><u>SITE PLAN</u></p> <p>44. A Site Plan shall be provided with permit plan set and include: north arrow, scale, property boundaries, topography, vegetation, proposed/existing structures,</p>	<p>A site plan shall be submitted with the improvement plans for the PX permit.</p>



<p>utilities, easements, roadways, monuments, wells, and any important key elements.</p>	
<p><b><u>STREET LIGHTS AND UTILITIES (PW ELECTRICAL)</u></b>          45. A photometric plan and analysis of existing and proposed street lights is required for all projects requiring a PX permit and as determined by the City Engineer. Design shall meet City Outdoor Lighting Standards.  <a href="http://www2.oaklandnet.com/oakca1/groups/pwa/documents/policy/oak026007.pdf">http://www2.oaklandnet.com/oakca1/groups/pwa/documents/policy/oak026007.pdf</a>.          46. Upon review and approval of the photometrics analysis, the project sponsor shall design and include additional streetlights as required by the City and shall also provide 10% spare streetlight fixtures for City’s Electrical Maintenance Operations.          47. Pedestrian signal and push buttons for intersection crossings shall be included in the plans for construction when required by the Traffic Engineer.          48. Utility undergrounding shall be clearly identified on all construction permitted plans as approved by the Project Planner, Oakland Fire Department, Public Works Department and Dept. of Transportation.          49. Pull boxes shall be locking.          50. Existing, reinstalled and new Streetlights, Parking Meters and Kiosks shall be included on the plans approved for construction. Separate fees and approvals by Public Works Maintenance is required to remove or install Streetlights, Parking Meters and Kiosk.</p>	<p>The improvement plans shall identify the location and details for all existing and proposed street lights along the street frontage of the proposed project. A photometric analysis shall be submitted as part of the PX permit application.</p>
<p><b><u>SPECIAL ZONES: CDMG Designation (LS/LQ), A-P Zone, Flood Zone, Creek/water course, GAAD, etc.</u></b>          51. Design, approvals, outside agency permits, and construction methods shall meet all applicable Federal, State, and City’s Municipal Code requirements for properties located in hazard zone and flood zone.          52. Peer Review of Soils, Geotechnical, Hydrology, Hydraulic, and Structural Reports, engineering plans, grading, remediation, final map may be required.          53. CDMG Designation and potential for liquefaction(LQ) and/or landslide(LS) shall be clearly identified on individual lots of the Tentative Map, Parcel Map of final Tract Map.</p>	<p>The improvement plans shall identify on the cover sheet the flood zone designation and FIRM rate map for the property. The Geotechnical Engineer and reference to soils reports shall also be included on the cover sheet of the improvement plans submitted for review and approval.</p> <p>The project side is within Liquefaction Severity 4 Hazard Zone.</p>
<p><b><u>TENTATIVE MAP, PARCEL MAP, TRACT MAP</u></b>          54. Fire Access, Emergency Vehicle Access, Shared Access (Agreement or CC&amp;R’s), Utility Easements shall be clearly shown and identified on Maps.          55. Setbacks from the property lines, buffer areas, easements, buildings and separation required between structures and buildings shall be identified on Tentative Map.          56. After approval by Planning and Zoning of a Tentative Map a separate application to Engineering Services is required for review and approval of the Parcel or Tract Map by the City Surveyor and City Engineer.          57. Tract Map and Subdivision Improvement Agreement (SIA) requires City Council Approval.          58. Survey Monuments Protection, Surety/Bond may be required prior to approval of Parcel or Final Map.</p>	<p>After approval by Planning and Zoning of a Tentative Parcel Map, a separate application to Engineering Service is required for review and approval of the Parcel Map by City Surveyor and City Engineer.</p>

**CITY OF OAKLAND Department of Transportation**  
*Engineering Services “Conditions of Approval”*

<p><b>CONSTRUCTION</b></p> <p>59. All work within the City’s right-of-way or easement requires a valid permit.</p> <p>60. Shoring Plans, Retaining Walls, Streetlight and Traffic Signal Pole Foundations and other structures require a separate Building Permit from the Building Department.</p> <p>61. An Obstruction Permit (OB) may be required prior to issuance of a Grading, Building, PX, CGS or another related permit. OB permits are required for temporary or permanent removal of metered and non-metered parking spaces, sidewalk closure(s), staging of materials, construction dewatering equipment, blocking, placement of storage units, equipment within the right-of-way.</p> <p>62. An approved Traffic Control Plan (TCP) may be required prior to issuance of an OB permit, PX permit or any work requiring Traffic Control Measures within the City’s right-of-way.</p>	<p>PX permit is required for offsite improvements. PX permit is required for each phase of the project.</p> <p>OB permit is required if there is any impacted parking space on street. Traffic Control Plan may be required prior to issuance to OB and PX permit.</p> <p>SL Permit is required for any new or abandoned sewer lateral.</p>
<p><b>OTHER</b></p> <p>63. Projects with “<i>Special</i>” considerations, for example; may require utility undergrounding of overhead utilities, improvements off-site (i.e. new traffic signal), ownership of land/project sponsor TCSE Economics &amp; Workforce Development, a City Capital Project, or may be part of a larger “Master Planned Development” with Development Agreement and/or phased Final Maps.</p>	<p>Conditions may apply at the time of a Building Permit application.</p>

**PER CITY RECORDS AND INFORMATION RECEIVED FOR REVIEW ITEMS NOTED BELOW MAY AFFECT THE DESIGN, REVIEW AND APPROVAL, PERMITTING, MAP APPROVAL PROCESSES.** *(The City assumes No Responsibility for the Accuracy and/or Completeness thereof.)*

Preliminary Title Report		Vacation / Dedication	
Flood Zone		Easement	
Creek Permit / Water Course		Existing Utilities / Overhead	
Land / Boundary Survey		BART	Bart needs to review and approve the design
Lot Dimension(s)		CALTRANS	
Sidewalk Clearance (i.e. 5.5 ft.)		EBMUD	
Sidewalk Curb Ramps		PG&E	
Encroachment		UPRR	
CDMG Designation		City of Oakland Ownership	
Land Stability	In Liquefaction Severity 4 zone	City of Berkley	
Street Lighting		City of Emeryville	
Traffic Circulation / Bicycle Lane		City of Piedmont	
Traffic Signal		Other	

\*Additional information is provided below:

1. Bart, Fire Department, Planning Department, AC Transit and DOT need to review and approve permit plans prior to PX permit issuance.
  2. The utility plan is conceptual design only. The new sewer main will cross the BART track (under) and needs Bart’s approval. Sewer structures rim, flow line elevation and profiles to be added for PX review.
- Investigation is needed on how and what size of sewer will run from 5th St to 3rd St on Center St. A hydraulic study is required to ensure sewer pipes have enough capacity to carry flow to EBMUD interceptor.
- Detail design review is required during PX permit review. It is unclear if the new sewer will be completely by pass the Sub-basin 64-11, there is no guarantee that sewer mitigation will not be imposed.

<b>Planning/Zoning Number</b>	<b>Map Number (if applicable)</b>	<b>DATE</b>
PLN18490-REV02, PLN18521-R01	VTPM10940	10/21/2020

## **Exhibit 3:**

### **Conditions of Approval**

1. Oakland Department of Transportation, City Surveyor  
Conditions of Approval



**CITY OF OAKLAND, Department of Transportation – Office of the City Surveyor**

*If the project is approved by the Advisory Agency, attach the Survey Department's "Conditions of Approval" provided below*

<u>Planning/Zoning Number(s)</u>				<u>Survey Staff Contact:</u>			
<u>Project Address</u>				<u>Project Description</u>			
<u>Tentative Map No.</u>		No. of New Lots		No. Condominiums		___ Mixed Use	
___ <u>No Map</u>	___ <u>Parcel Map Waiver</u>	___ Merger	___ Lot Line Adjustment LLA	No. Existing Lots LLA		No. New Lots LLA	
<b><u>GENERAL</u></b> <b><u>CONDITIONS OF APPROVAL</u></b>				<b><u>SPECIFIC PROJECT</u></b> <b><u>CONDITIONS OF APPROVAL</u></b>			
<u>FINAL PARCEL MAP/TRACT MAP</u>							
<ol style="list-style-type: none"> <li>The final parcel map shall clearly show the process and development of the location of the boundary lines from adjoining streets and boundaries. This includes how the depth of the lot was confirmed.</li> <li>Depending upon this process, and at discretion of the City Surveyor, a standard city monument(s) or a private monument meeting City specifications may be required to be installed at an approved location.</li> <li>If the tentative map does not cite a specific Benchmark as the basis for the City of Oakland Datum, or if then as a <b>Condition of Approval</b>, a Standard City Benchmark shall be installed at the nearest intersection, or as directed by the City Surveyor, and the appropriate paperwork submitted to this office for approval. Additionally, a Standard City Benchmark may be required where there is an absence of benchmarks along nearest block intersections.</li> <li>The applicant must investigate and confirm, in writing, that no portion of the project lies with a Seismic Hazard area as shown upon the State Geologist maps (<b>reference is made to PRC Division 2, Chapter 7.8 section 2696</b>). If the project does lie within such an area, the appropriate certificate shall be added to the final map. A copy of this certificate is available from the City.</li> </ol>							
<u>TENTATIVE MAPS</u>							
<ol style="list-style-type: none"> <li>The tentative map is filed in conformance with Subdivision Map Act §66452 and Title 16 requirements (16.24.100 and 16.24.070)</li> <li>Surveyor's Statement on the map written in accordance with Section 15.04.2.223 of the Oakland Municipal Code.</li> <li>Elevations: Are based upon the City of Oakland Datum and must cite the City Benchmark used to establish the elevations. Note: <b><u>Curb return elevations are not acceptable.</u></b></li> <li>All proposed easements/quitclaimed easements must be shown on the tentative map. All existing easements must be shown with corresponding instrument numbers.</li> </ol>							

<p><u>CONDOMINIUMS</u></p> <p>9. In any common interest developments, the HOA may be required to address the utilities, vehicular access, common areas, and parking to each unit in the Covenants, Conditions, Rules and Restrictions (CC&amp;Rs) for this project.</p> <p>10. <i>Condo Conversion:</i></p> <ul style="list-style-type: none"> <li>A) Requirements for Noise abatement/insulation prior to the sale of any unit.</li> <li>B) Requirements for CC&amp;Rs approved by planning prior to occupancy.</li> <li>C) Recordation of the final map must be completed prior to the issuance of a certificate of occupancy.</li> </ul>	
<p><u>ENCROACHMENTS</u></p> <p>11.No portion of any new structure shall extend beyond the boundary lines without the appropriate easement. Portions which will extend beyond the ROW line must be approved by the Right of Way Engineer.</p> <p>12.Neighboring fence encroachments <math>\geq 0.50'</math> must be resolved by one of the following:</p> <ul style="list-style-type: none"> <li>A)Removal</li> <li>B)Relocation</li> <li>C)Agreement/Easement with neighbor</li> <li>D)Showing the fence lines on parcel map submittal</li> </ul> <p>13. Building encroachments <math>\geq 0.30'</math> must be resolved by the following:</p> <ul style="list-style-type: none"> <li>A)Removal</li> <li>B)Relocation</li> <li>C)Easement</li> <li>D)Written agreement or contract with neighbor (less desirable option)</li> </ul>	
<p><u>OTHER</u></p> <p>14. Remainder Parcel (see right)</p>	

**Exhibit 4:**

**Conditions of Approval**

- **Oakland Fire Department Conditions of Approval**

# CITY OF OAKLAND

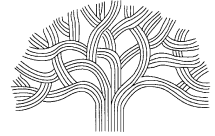

OAKLAND FIRE DEPARTMENT  
FIRE PREVENTION BUREAU  
250 Frank H. Ogawa Plaza • Suite 3341 • Oakland, California 94612-2033

Reviewed by: Anita Tsui, P.E.  
Phone (510) 238-3866  
Email: atsui@oaklandca.gov

(510) 238-3854  
FAX (510) 238-6739  
TDD(510) 238- 3254

**Vesting Tentative  
Parcel Map  
PLN18521/TPM10940**

**West Oakland Bart  
1451 7<sup>th</sup> Street  
Oakland, CA**

**OFD # 2020-00188  
Date: 10.01.20**

## **FIRE REVIEW CONDITIONS OF APPROVAL**

This is a review for OFD code issue only. If the project is to be approved by the advisory agency please attach the following conditions of approval:

Note that these conditions of approval are based on the current code. OFD reserves the right to enforce provisions effective at the time an application for building permit.

*Ref: CBC: 1.1.9 Effective date of this code Only those standards approved by the California Building Standards Commission that are effective at the time an application for building permit is submitted shall apply to the plans and specifications for, and to the construction performed under, that permit. For the effective dates of the provisions contained in this code, see the History Note page of this code.*

Description of Work: Vesting Tentative Parcel Map related to PUD @ West Oakland BART Station. Involves alterations to property lines. Overall project size is 5.5 acres (241,282).

1. The existing public street frontages shall have a minimum clear road width for fire apparatus access road per CFC Appendix D. Verify and confirm if Chester Street, 5<sup>th</sup> Street and Mandela Parkway meet the requirement. Permit application needs to apply for a code variance and submit AMMR when the existing public street width does not meet the required minimum clear road width. Enhancements to the fire protection systems will be required as mitigations to the code variance and it will be determined at the time of building permit application.
2. Plaza elements must provide a designated, unimpeded emergency access route without unnecessary obstacles (e.g., sculptures, benches, seating, landscaping, or walls of any kind) incorporating hardscape features capable of accommodating and supporting fire apparatus weight.
3. Provide designated parking for ambulance, BART maintenance vehicles and BART agent vehicles to ensure no vehicles will be parked on EVAs.
4. Provide retractable bollards with keypad and Knox key at EVAs for ambulance access.
5. Provide an approved key box or apparatus-based remote control for the security gate at EVA per CFC 503 and CFC 506.
6. Command Post shall be located at the Bart Station, not inside the proposed building at Lot 1, Lot 2 or Lot 3. Provide storage area for Transbay Tube OFD supplies at BART platform level or inside Incident Command Post. Incident Command Post shall be minimum 200 square feet, not including area for storage. Discuss with OFD for preferred location.
7. Evacuation plans must account for calculated capacities, and provide adequate egress from BART facilities,

retail spaces and high-rise/mid-rise structures combined.

8. All exterior exit stairways from the proposed buildings shall exit to public streets, not to EVAs.
9. Provide sidewalks at the exits of the retail spaces and art spaces of the proposed buildings.
10. Verify and confirm the existing public fire hydrants shall be provided along all fire department access roads with a maximum travel distance of 150 feet to the buildings, or 300 feet hydrant to hydrant as required in 2019 CFC Appendix C and City Ordinance 13577 amended CFC 507.5.1.
11. Provide 2-1/2 inches Fire Department Connection at each street and EVA frontage of each proposed building on site. Fire Department Connections at Mandela Parkway and Chester Street shall be ground-supported FDC's facing and accessible from the streets with Emergency Vehicle Parking Only in front of it.

When the fire department connection is located within 10 feet of the corner of a building adjacent to the fire department access, the fire department connection shall service both streets. Ref.: 2019 City Ord. 13577 amendment to 2019 CFC Chapter 80 adoption 2016 NFPA 13 Section 8.17.2.4.6.

Fire Department Connections attached to building walls and/or ground-supported FDC's shall be within 100 feet of existing or new hydrants on the same side of the street. Ref.: 2016 NFPA 14.

12. Provide an additional 2-1/2 inches Fire Department Connection for BART station at 7<sup>th</sup> Street. It shall be ground-supported FDC's facing and accessible from the streets.
13. Fire apparatus access roads shall be all-weather driving surface capable of supporting a minimum 75,000 pounds' fire apparatus load.
14. Provide property address. Property address signs for the buildings shall comply with 2019 CFC 505.
15. Verify and confirm the utility and power lines shall not obstruct aerial fire apparatus access between the roadway and the building per 2019 CFC D105. Undergrounding of utilities and power lines is an acceptable means to meet this condition.
16. Verify/Obtain separate permits from Fire Prevention Bureau required for installation, permitted activity of:
  - Installation of fire sprinkler systems
  - Installation of standpipe system
  - Installation of underground piping
  - Installation of fire alarm system
  - Installation of emergency responder radio coverage system
  - Installation of automatic extinguishing system to commercial kitchen hoods
  - Fire safety and evacuation plans
  - PX
  - PZ
  - Hazardous materials, if applicable
  - AMMR, if applicable
17. Provide fire command center (FCC) at each proposed building per City Ordinance 13577 amended 2019 CFC 508. FCC shall be located at the main entrance lobby.
18. Provide emergency responder radio communications coverage. Ref.: 2019 CFC Section 510:
19. Provide an approved fire sprinkler system for all proposed buildings on site per City Ordinance 13577. Separate Permit required from Fire Prevention Bureau for fire sprinkler system. Hydraulic fire flow analysis



shall be submitted for review of EBMUD's Water Service and Hydrant Application

20. All drains shall discharge to sewer or open planter areas only; not to storm drains per City's retroactive Clean Water Program. Drains to sewer shall comply with California Plumbing Code. NFPA 13 may be used as a guide (i.e., air gap required between drain outlet and plumbing fixture. Coordinate with CEDA Building Services Building Inspector).
21. Coordinate with Hazardous Material Unit (Ms. Sheryl Skillern, 510.238.7253, sskillern@oaklandca.gov) for inspections and submittal requirements if any hazardous materials found at the site during evacuation and demolition.
22. Observe fire safety during demolition and construction work per 2019 CFC Chapter 33.

# CITY OF OAKLAND

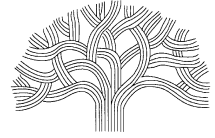

OAKLAND FIRE DEPARTMENT  
FIRE PREVENTION BUREAU  
250 Frank H. Ogawa Plaza • Suite 3341 • Oakland, California 94612-2033

Reviewed by: Anita Tsui, P.E.  
Phone (510) 238-3866  
Email: atsui@oaklandca.gov

(510) 238-3854  
FAX (510) 238-6739  
TDD(510) 238- 3254

**Final Development  
Plan – Horizontal  
Improvements, T1, T3  
PLN18490-REV01-  
PUDF01/ PUDF02/  
PUDF03**

**West Oakland Bart  
1451 7<sup>th</sup> Street  
Oakland, CA**

**OFD # 2020-00189  
Date: 10.01.2020**

## FIRE REVIEW COMMENTS

This is a review for OFD code issue only. If the project is to be approved by the advisory agency please attach the following conditions of approval:

Note that these conditions of approval are based on the current code. OFD reserves the right to enforce provisions effective at the time an application for building permit.

*Ref: CBC: 1.1.9 Effective date of this code Only those standards approved by the California Building Standards Commission that are effective at the time an application for building permit is submitted shall apply to the plans and specifications for, and to the construction performed under, that permit. For the effective dates of the provisions contained in this code, see the History Note page of this code.*

Description of Work:

**PUDF01:** Final Development Plan for West Oakland BART TOD high-rise tower at site T-1 (522-residential units, 14,207 sf retail and 320' tall). Includes 140 parking spaces

**PUDF02:** Horizontal Improvements for entire West Oakland Station site. Includes three public plazas and CGS improvements.

**PUDF03:** T3- an 80' tall, 240 Affordable Units and 22 Town Homes (262 units total). Includes Vesting TPM \_\_\_\_\_ to create 11 parcels.

1. The existing public street frontages shall have a minimum clear road width for fire apparatus access road per CFC Appendix D. Verify and confirm if Chester Street, 5<sup>th</sup> Street and Mandela Parkway meet the requirement. Permit application needs to apply for a code variance and submit AMMR when the existing public street width does not meet the required minimum clear road width. Enhancements to the fire protection systems will be required as mitigations to the code variance and it will be determined at the time of building permit application.
2. Current EVAs must maintain current width during construction.
3. Plaza elements must provide a designated, unimpeded emergency access route without unnecessary obstacles (e.g., sculptures, benches, seating, landscaping, or walls of any kind) incorporating hardscape features capable of accommodating and supporting fire apparatus weight.
4. Provide designated parking for ambulance, BART maintenance vehicles and BART agent vehicles to ensure

no vehicles will be parked on EVAs.

5. Provide retractable bollards with keypad and Knox key at EVAs for ambulance access.
6. Provide an approved key box or apparatus-based remote control for the security gate at EVA per CFC 503 and CFC 506.
7. Incident Command Post shall be located at the Bart Station, not inside the proposed building at Lot 1, Lot 2 or Lot 3. Provide storage area for Transbay Tube OFD supplies at BART platform level or inside Incident Command Post. Incident Command Post shall be minimum 200 square feet, not including area for storage. Discuss with OFD for preferred location.
8. Evacuation plans must account for calculated capacities, and provide adequate egress from BART facilities, retail spaces and high-rise/mid-rise structures combined.
9. All exterior exit stairways from the proposed buildings shall exit to public streets, not to EVAs.
10. Provide sidewalks at the exits of the retail spaces and art spaces of the proposed buildings.
11. Verify and confirm the existing public fire hydrants shall be provided along all fire department access roads with a maximum travel distance of 150 feet to the buildings, or 300 feet hydrant to hydrant as required in 2019 CFC Appendix C and City Ordinance 13577 amended CFC 507.5.1.
12. Provide 2-1/2 inches Fire Department Connection at each street and EVA frontage of each proposed building on site. Fire Department Connections at Mandela Parkway and Chester Street shall be ground-supported FDC's facing and accessible from the streets with Emergency Vehicle Parking Only in front of it.

When the fire department connection is located within 10 feet of the corner of a building adjacent to the fire department access, the fire department connection shall service both streets. Ref.: 2019 City Ord. 13577 amendment to 2019 CFC Chapter 80 adoption 2016 NFPA 13 Section 8.17.2.4.6.

Fire Department Connections attached to building walls and/or ground-supported FDC's shall be within 100 feet of existing or new hydrants on the same side of the street. Ref.: 2016 NFPA 14.

13. Provide an additional 2-1/2 inches Fire Department Connection for BART station at 7<sup>th</sup> Street. It shall be ground-supported FDC's facing and accessible from the streets.
14. Fire apparatus access roads shall be all-weather driving surface capable of supporting a minimum 75,000 pounds' fire apparatus load.
15. Provide property address. Property address signs for the buildings shall comply with 2019 CFC 505.
16. Verify and confirm the utility and power lines shall not obstruct aerial fire apparatus access between the roadway and the building per 2019 CFC D105. Undergrounding of utilities and power lines is an acceptable means to meet this condition.
17. Verify/Obtain separate permits from Fire Prevention Bureau required for installation, permitted activity of:
  - Installation of fire sprinkler systems
  - Installation of standpipe system
  - Installation of underground piping
  - Installation of fire alarm system
  - Installation of emergency responder radio coverage system
  - Installation of automatic extinguishing system to commercial kitchen hoods
  - Fire safety and evacuation plans

- PX
  - PZ
  - Hazardous materials, if applicable
  - AMMR, if applicable
18. Provide fire command center (FCC) at each proposed building per City Ordinance 13577 amended 2019 CFC 508. FCC shall be located at the main entrance lobby.
  19. Provide emergency responder radio communications coverage. Ref.: 2019 CFC Section 510:
  20. Provide an approved fire sprinkler system for all proposed buildings on site per City Ordinance 13577. Separate Permit required from Fire Prevention Bureau for fire sprinkler system. Hydraulic fire flow analysis shall be submitted for review of EBMUD's Water Service and Hydrant Application
  21. All drains shall discharge to sewer or open planter areas only; not to storm drains per City's retroactive Clean Water Program. Drains to sewer shall comply with California Plumbing Code. NFPA 13 may be used as a guide (i.e., air gap required between drain outlet and plumbing fixture. Coordinate with CEDA Building Services Building Inspector).
  22. Coordinate with Hazardous Material Unit (Ms. Sheryl Skillern, 510.238.7253, sskillern@oaklandca.gov) for inspections and submittal requirements if any hazardous materials found at the site during evacuation and demolition.
  23. Observe fire safety during demolition and construction work per 2019 CFC Chapter 33.

**ATTACHMENT I:**

**Mandela Station Public Art Program, September 16, 2020**



**MANDELA STATION  
PUBLIC ART SUMMARY**

## **Mandela Station Art Implementation Strategy**

The Mandela Station mixed-use TOD presents a host of unique opportunities for the strategic incorporation of art and storytelling into the fabric of the project. This high-density village is comprised of 762 apartments in two buildings and a 300,000 sf office building, connected by 53,000 sf of neighborhood retail, cultural spaces, and plazas. The project has the potential to benefit greatly from the rich cultural legacy of the West Oakland community as well as the collective creative power of the surrounding artists community. Art will be strategically integrated to provide a welcoming experience that showcases Oakland at its aesthetic finest – while also making a profound statement on equitable development and environmental sustainability.

Achieving the above, with the highest level of artistic expression, feasibility, and sustainability will require an ongoing and pragmatic art planning and implementation process which is currently underway. Over the past three years the development team has undertaken an intensive community engagement process and taken particular steps to integrate art into all aspects of the planning process. The collective planning efforts foster the evolution of a creative art implementation plan that, among many benefits, that maximizes the attractiveness, appeal, marketability, and value of its ideal transit-oriented location. As such, the development team’s ultimate plans will be in full compliance with, and go far beyond, the provisions of Oakland Municipal Code- Chapter 15.78 which outlines the “PUBLIC ART REQUIREMENTS FOR PRIVATE DEVELOPMENT”. The preliminary project construction evaluation is nearly \$775MM, therefore allowing an estimated \$2.58 MM public art budget.

### **Art Implementation Goals & Objectives**

Given the relatively high visibility of the project’s location at the West Oakland Bart Station, the development team is engaging in a comprehensive planning process to develop and implement a Strategic Art Implementation Plan (SAIP), among other priorities, to bring about the following prioritized objectives and outcomes:

- provide for the commemorative celebration of the rich cultural legacy of West Oakland community
- enhance the design aesthetic and appeal of the project
- provide prominent opportunities for showcasing the works of emerging and local artist
- create branding and buzz to enhance the marketability, attractiveness of the project for prospective retail, office, and residential tenants.
- create a sense of an art and culture rich experience to attract BART-riders, and other regional commuters to patronize the ground floor retail stores and vendors.

# MANDELA STATION

DRAFT Version #5

## PROJECT SITE PLAN

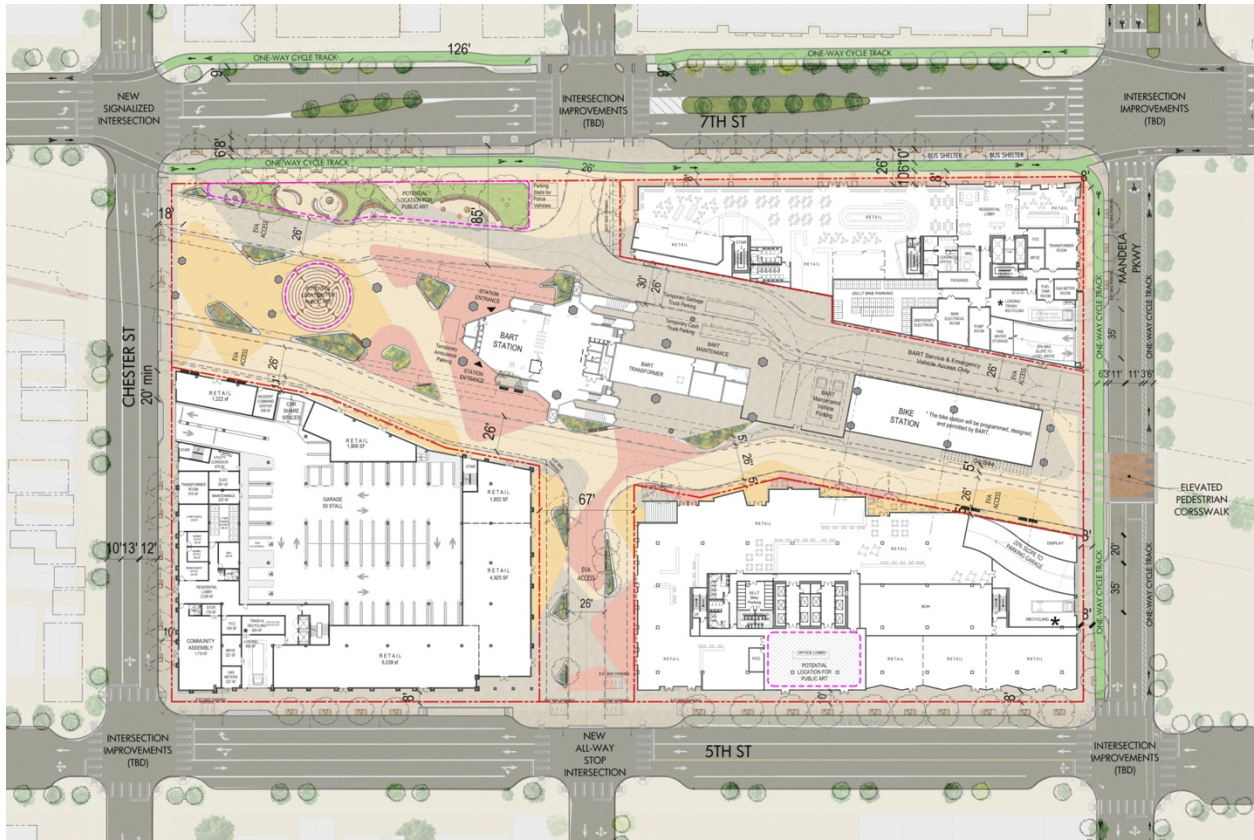

## Public Art Locations

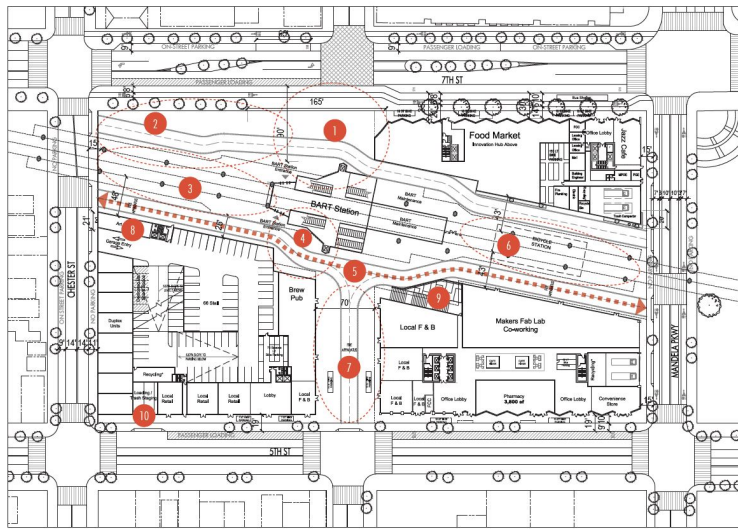



### Elements of the Strategic Art Implementation Plan:

The Mandela Station SAIP, includes both horizontal and vertical aspects of the development, and encompasses both permanent installations and “curated” installations that will be carefully chosen, thoughtfully organized, and changed on an annual or semi-annual basis. The general plan elements include:

- Art Wall and Cultural Spaces
- Plaza Art - General
- Plaza Art - Interactive Art
- Historic Commemorative Depictions
- Sculpture
- Earthworks

The above program elements will be independent initiatives, however, the development team will establish coordinated processes to assure continuity and compatibility of the permanent and curated installations of art throughout the life of the project.

### PROPOSED PUBLIC ART LOCATIONS

Art Site: T3-Art Wall and Cultural Spaces

The north facing wall of building T-3, an approximately 16,000 sf vertical surface, presents an ideal opportunity to incorporate art works to capture the attention of nearly 235,000 rider per day that typically pass through the West Oakland BART station. It is the objective of the developers to design this vertical gallery wall in a manner that will allow for a curated collection of paintings and sculpture to change over time. This will allow us to feature many more artists who make up Oakland’s exciting arts community.

However, it should be noted that the T3-Art Wall will also be designed in a manner that is acceptable to, and approved by, the planning commission without art. This will allow the development team the ability to pragmatically establish a process for, among other activities; selecting art; establish funding sources; and establish a selection committee to decide on the artists to be commissioned and the art to be incorporated. This approval of the wall without art will also assure that adequate time can be taken between exhibits to identify and procure installations of the highest quality and appropriateness. Furthermore, this “finished “ wall will provide an acceptable alternative in the unlikely event that the rotating art is not feasible.

Additionally, two spaces are designated for cultural uses below the Art Wall of the ground floor retail. These spaces could serve as the home of local arts and cultural organizations.

## DRAFT Version #5

### **Art Site: Mandela Station Plaza and BART Entry**

The Mandela Plaza will be comprised of entry to the BART transit station, as well as access to restaurants, and retail shops. An intimately scaled plaza, fronting along Seventh Street, will serve as the area's "living room," welcoming West Oakland residents of all ages to gather for informal and special events. Interactive art, permanent sculptural overhead elements, unique lighting or designs incorporated into the hardscape and landscape, including unique furnishings will be incorporated as art elements into the plaza.

### **Art Site: The Oakland Walk of Fame: The Music They Played on Seventh Street**

During the early phase of required infrastructure improvements, the existing plaques marking historic music landmarks, will be carefully removed and stored in a protective facility. Once the Seventh Street infrastructure work is completed, the Walk of Fame plaques will be reinstalled on Seventh Street sidewalks. This effort will be facilitated by the West Coast Blues Society.

### **Art Site: Blue Dancing Lights**

Also due to early phase infrastructure improvements, the existing blue "Dancing Lights " will be removed from their Seventh Street location. The applicant will work with the community, the City of Oakland Department of Transportation, and Walter Hood Design Studios (the original design firm) to determine any plans for relocation.

### **Art Site: Center Street Plaza and Monumental Stair**

Facing onto retail spaces with outdoor seating for dining this plaza and stair offer opportunities for unique seating, railings and small earthworks reflecting the local maker artists community including the nearby arts institution, The Crucible.

### **Art Site: Office Building Lobby**

The large-scale office lobby facing on to 5<sup>th</sup> Street and industrial buildings could support a major sculptural work such as the sculptures created by internationally acclaimed local artist Bruce Beasley or the many local artists engaged in productions for the annual Burning Man Festival.

### **Art Site: BART Undertrack Columns**

The undertrack is massive and unsightly, however the bulky columns could be painted creatively by Oakland youth enrolled arts organization programs such as the Art Esteem program by Attitudinal Healing depicting local children as superheroes or local mural collectives.

**PRELIMINARY ESTIMATE OF PUBLIC ART DEVELOPMENT BUDGET**

<u>PHASE 1 Residential Buildings</u>		
Building T-1: -	Construction Budget	\$265,000,000
Building T-3 -	100% Affordable Res. Bldg. Exempt from Public Art Ordinance Requirement	
<b>Art Allocation for PHASE 1: 0.5%:</b>		<b>\$1,325,000</b>
<u>PHASE 2 Office Building</u>		
Building T-4:	Construction Budget	\$125,000,000
Art Allocation:	1.0%	<b>\$1,250,000</b>
=====		
<b>Total Estimated Applicable Art Budget</b>		<b>\$2,575,0000</b>

**PLANNING PROCESS**

Establishing the comprehensive integrated Strategic Art Implementation Plan (SAIP) will include, but not be limited to, the following activities:

Selection of Art/Landscaping consultant(s) for coordination of the overall TOD planning and coordination (November 2020)

(It should be noted that art/landscaping consultant(s) scope of service will range from coordination of the standard project or program-to facilitating the collaborative processes that will allow for the ongoing curation of the Art Wall. For more comprehensive range of the consultant(s) proposed activities please see the attached DRAFT scope of services.)

- Community Outreach Follow-up & Feedback (December 2020)
- Establish covenants to provide for the long-term maintenance and preservations of art installations. (January 2021)
- Establishing “Art Wall Gallery” advisory, review, and selection committee (March 2021)
- Establishing a guidelines and process for curation of the “Art Wall” (June 2021)
- Establishing a funding strategy for the ongoing curation “Art Wall” (June 2021)
- Selection of Plaza and outdoor common area art and locations (February 2022)
- Selection of interactive art Plaza (February 2022)

The public art consultant(s) will prepare an RFQ process for each public art site, and seek professional artists to submit proposals that respect the history and culture of West Oakland, and that take advantage of the high visibility of the sites. Proposals submitted by artists will be juried by a selection panel made up of local arts organization leaders, Bay Area artists,

## **DRAFT Version #5**

architects and arts educators, as well as members of the West Oakland Community Advisory Committee, the development team, and staff from BART and the Oakland Cultural Affairs Department.

### **SPECIFIC TO THE ART WALL:**

The successful implementation of the “rotating” art Wall will provide a profound ongoing value to the West Oakland community as well as our development team. However, it’s viability will require careful planning and reconciliation with many complex aspects of the mixed-use development (i.e. reciprocal easement agreements, long-term replenishable budget provisions, and schedule coordination).

Undertaking the Art Wall given the natural complexities of a mixed-use development - will ultimately require the services of a range of expert consultants to cover the breadth of real estate development as well as art curation expertise. Our development team collectively has all the experience and capability required to manage and oversee a process that includes bringing the proper experts to the table at the proper time.

Determination of who will manage/curate future installations requires careful coordination and reconciliation with several aspects of the mixed-use development at Mandela station. This will ultimately be determined as part of the community-oriented process described above.

Determination of how often installations will be changed requires careful coordination and reconciliation with several critical factors - and will be ultimately determined based on significant community outreach, expert opinions, and financial considerations - including provisions of the reciprocal easement agreements of the mixed use development at Mandela station.

Approximately 5 % of the Public Art Requirement fund will be allocated to the permanent structural embeds that will be installed to support the art wall installations - and another 5% will be allocated to permanent davits and other apparatus that is required to install, maintain and, and replace rotating exhibits . Future installations will be paid for from the proceeds of grants, sponsorships, and other sources as will be identified as part of our comprehensive budgeting process.

We have submitted a design of a “finished” wall for consideration by both the planning commission and the community. This proposed wall, as designed, has received overwhelmingly favorable community feedback and support. The wall is exceptional by comparison to other walls approved by the planning commission. We feel confident that this “finished “ wall will provide an acceptable alternative in the unlikely event that the rotating art is not feasible as well as in between rotating collections.

### **CONCLUSION**

### **DRAFT Version #5**

The visual quality of the region's mass transit system has a profound impact on the community at large and its riders. Art can give vibrancy to public spaces and foster a sense of belonging. Art at Mandela Station, much like its namesake, intends to be an agent of change. To transform a BART parking lot into an equitable and dignified village, Mandela Station will use art like a hammer.