

**Appendix A**  
Supplemental Transportation  
Analysis – Mountain Boulevard  
Revised Site Access Design  
Analysis (at Retail Village  
Driveway) (January 2017)

# **Oak Knoll Mixed Use Community Plan Project – Mountain Boulevard Revised Site Access Design Analysis**

January 20, 2017

OK14-0026

FEHR  PEERS



## Table of Contents

**INTRODUCTION**..... 2

**BACKGROUND**..... 2

**STUDY INTERSECTION DESIGN CHANGES**..... 3

**TRAFFIC OPERATIONS ANALYSIS** ..... 3

Intersection Peak Hour Signal Warrant Analysis.....4

## Appendices

- Appendix A: Mountain Boulevard Site Access Design Plan
- Appendix B: Intersection Analysis Worksheets
- Appendix C: Signal Warrant Analysis Worksheets

## List of Tables

**Table 1** – 2040 Plus Project Intersection Level of Service Summary ..... 4

**Table 2** – 2040 Plus Project Intersection Peak Hour Signal Warrant Analysis..... 5

## INTRODUCTION

This report summarizes the traffic operations analysis for the following Oak Knoll site access intersections along Mountain Boulevard to account for recent modifications proposed at these two intersections:

- Mountain Boulevard/Retail Village Driveway (intersection #24)
- Mountain Boulevard/Creekside Parkway (intersection #42)

The proposed design changes at both study intersections listed above would provide adequate capacity for estimated intersection turning movement forecasts assuming 2040 Plus Project Conditions. The design modifications are not expected to cause new significant impacts or change the conclusions of the Draft Supplemental Environmental Impact Report (SEIR) findings.

## BACKGROUND

Both intersections were evaluated as part of the Draft SEIR for the proposed Oak Knoll project, which was published for public review on August 29, 2016. The traffic operations analysis summarized in the Draft SEIR assumed the following lane configurations and traffic controls at these intersections:

- Mountain Boulevard/Retail Village Driveway (intersection #24)
  - Side-street stop controlled
  - Northbound approach – one shared through/right-turn lane (un-controlled)
  - Southbound approach – one through lane (un-controlled), left-turn movements prohibited
  - Westbound approach – one right-turn lane (stop-controlled), left-turn movements are prohibited
- Mountain Boulevard/Creekside Parkway (intersection #42)
  - Traffic signal controlled
  - Northbound approach – one shared through/right-turn lane
  - Southbound approach – one left-turn lane, one through lane
  - Westbound approach – one left-turn lane, one right-turn lane

As described above, the Retail Village driveway was assumed to be side-street stop controlled with right-in/right-out only access (left-turns prohibited); the Creekside Parkway intersection was assumed to be signalized with full access. Since the August 2016 publishing of the Draft SEIR, the Oak Knoll project team prepared detailed roadway design plans for the site access intersections on Mountain Boulevard. During that process, the project team revised the design for these two study intersections; the design plans for all

other site access intersections are expected to remain the same as what was evaluated in the Draft SEIR. The proposed design changes and resulting traffic operations analysis are described below. The modifications to site access design are not expected to change the conclusions of the traffic operations impact analysis summarized in the Draft SEIR.

## STUDY INTERSECTION DESIGN CHANGES

The latest design plan for the primary Mountain Boulevard site access intersections is provided in **Appendix A**. The design plan assumes the following lane configurations and traffic controls:

- Mountain Boulevard/Retail Village Driveway (intersection #24)
  - Side-street stop controlled
  - Northbound approach – one shared through/right-turn lane (un-controlled)
  - Southbound approach – one left-turn lane, one through lane (un-controlled)
  - Westbound approach – one shared left-turn/right-turn lane (stop-controlled)
- Mountain Boulevard/Creekside Parkway (intersection #42)
  - Traffic signal controlled
  - Northbound approach – one through lane, one shared through/right-turn lane
  - Southbound approach – one left-turn lane, one through lane
  - Westbound approach – one left-turn lane, one right-turn lane

The primary changes relative to the Draft SEIR assumptions include the provision of left-turn access at the Mountain Boulevard/Retail Village Driveway intersection (#24) and the provision of a second northbound through lane at the Mountain Boulevard/Creekside Parkway intersection (#42).

## TRAFFIC OPERATIONS ANALYSIS

The proposed changes to site access intersections described above would result in a re-distribution of traffic volumes between the intersection on Mountain Boulevard at the Retail Village Driveway and Creekside Parkway. **Table 1** summarizes the 2040 Plus Project traffic operations analysis results for both study intersections assuming the revised intersection volume forecasts, lane configurations and traffic controls. **Appendix B** provides the intersection analysis worksheets, which also summarize the revised intersection volume forecasts. The analysis presented in this report focuses on 2040 Plus Project Conditions, which assumes higher traffic volume forecasts than Existing Plus Project Conditions. Although analysis results are not presented for Existing Plus Project Conditions, the average intersection delay is expected to be less than or equal to the average delay under 2040 Plus Project Conditions.

**TABLE 1**  
**2040 PLUS PROJECT INTERSECTION LEVEL OF SERVICE SUMMARY**

Intersection	Peak Hour	Draft SEIR Results – August 2016			Revised Site Access Design Results – January 2017		
		Control <sup>1</sup>	Delay <sup>2</sup>	LOS <sup>3</sup>	Control <sup>1</sup>	Delay <sup>2</sup>	LOS <sup>3</sup>
24. Mountain Boulevard/ Retail Village Driveway	AM	SSSC	1.5 (19.4)	A (C)	SSSC	1.1 (23.8)	A (C)
	PM		2.0 (10.7)	A (B)		3.6 (17.4)	A (C)
42. Mountain Boulevard/ Creekside Parkway	AM	Signal	15.2	B	Signal	11.5	B
	PM		13.5	B		10.6	B

Note:

1. Signal = signalized intersection; SSSC = side-street stop-control.
2. Average control delay in seconds per vehicle; for SSSC intersections, results shown as: average intersection delay and LOS (worst movement delay and LOS).
3. LOS = Level of Service per HCM 2010 methodologies

Source: Fehr & Peers, January 2017.

As shown in Table 1, both study intersections are expected to continue to operate at level of service (LOS) C or better during the AM and PM peak hours assuming the latest intersection design. Providing left-turn access at the Mountain Boulevard/Retail Village Driveway intersection is expected to increase the average side-street stop controlled delay at the intersection, while decreasing the average delay at the Mountain Boulevard/Creekside Parkway intersection (relative to the analysis results presented in the Draft SEIR).

## INTERSECTION PEAK HOUR SIGNAL WARRANT ANALYSIS

The peak hour volume traffic signal warrant (Warrant 3) for urban conditions, found in the *California Manual on Uniform Traffic Control Devices* (MUTCD) was evaluated for the two study intersections assuming the latest 2040 Plus Project AM and PM peak hour forecasts. As shown in **Table 2**, the Mountain Boulevard/Retail Village Driveway intersection is not expected to meet the peak hour signal warrant under 2040 Plus Project Conditions. The Mountain Boulevard/ Creekside Parkway intersection is expected to meet the peak hour signal warrant under 2040 Plus Project Conditions; the analysis presented in the Draft SEIR and in this report assumes that the intersection would be signalized. Detailed signal warrant calculations are provided in **Appendix C**.

**TABLE 2**  
**2040 PLUS PROJECT INTERSECTION PEAK HOUR SIGNAL WARRANT ANALYSIS**

<b>Location</b>	<b>Control Assumed in Draft SEIR<sup>1</sup></b>	<b>Peak Hour Warrant Met? (Draft SEIR Results – August 2016)</b>	<b>Peak Hour Warrant Met? (Revised Site Access Design Results – January 2017)</b>
24. Mountain Boulevard/ Retail Village Driveway	SSSC	No	No
42. Mountain Boulevard/ Creekside Parkway	Signal	Yes	Yes

Notes:

1. SSSC = side-street stop-control; Signal = signal-control.

Source: Fehr & Peers, January 2017.

**APPENDIX A: MOUNTAIN BOULEVARD SITE ACCESS DESIGN PLAN**

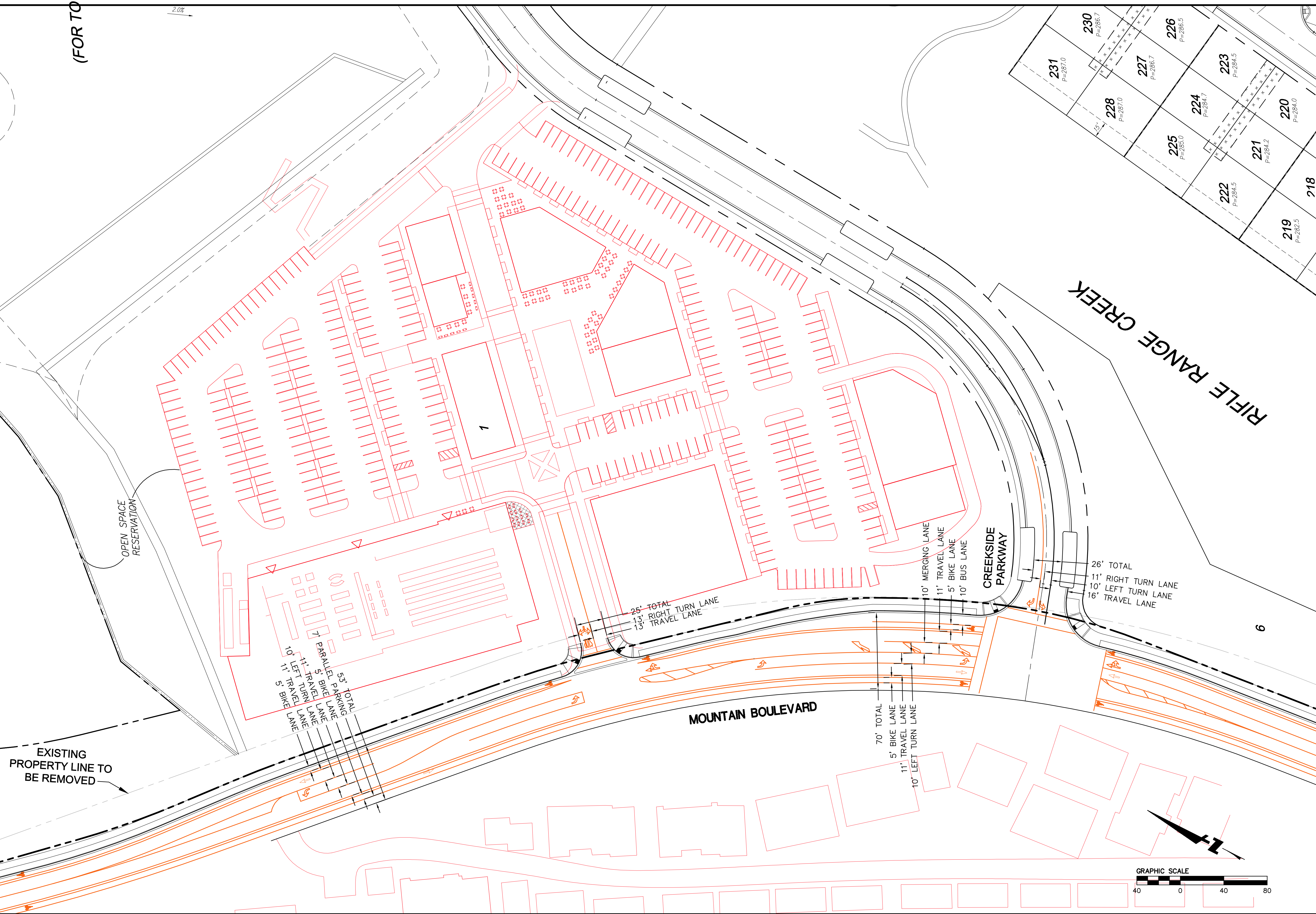




K:\ENG05\056154\DWG\EXHIBITS\Retail\Parcel\RETAIL PARCEL.dwg 19 Jan 2017 1:43:45pm artd

(FOR TO

2.0%



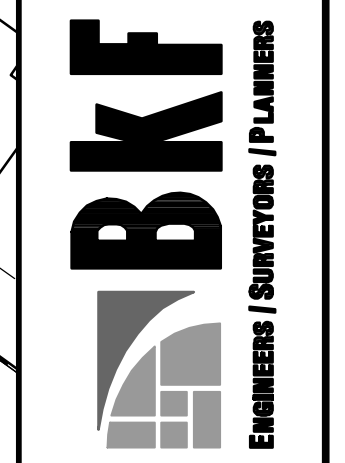
Date	No.	Revisions
01/19/17		

Date: 01/19/17  
 Scale: 1"=40'  
 Design: TC  
 Drawn: EA  
 Approved: JN  
 Job No: 200604

Drawing Number: **EX-1.0**

OAK KNOLL  
 PROPOSED OFF-SITE  
 TRANSPORTATION IMPROVEMENTS

OAKLAND  
 ALAMEDA COUNTY  
 CALIFORNIA



BKF ENGINEERS  
 1730 N. FIRST STREET  
 SUITE 600  
 SAN JOSE, CA 95112  
 408-467-9100 (PHONE)  
 408-467-9199 (FAX)

**APPENDIX B: INTERSECTION ANALYSIS WORKSHEETS**



**Intersection**

Int Delay, s/veh 1.1












Movement	WBL	WBR	NBT	NBR	SBL	SBT
Lane Configurations	Y		P		T	T
Traffic Vol, veh/h	21	21	927	37	37	214
Future Vol, veh/h	21	21	927	37	37	214
Conflicting Peds, #/hr	0	2	0	2	2	0
Sign Control	Stop	Stop	Free	Free	Free	Free
RT Channelized	-	None	-	None	-	None
Storage Length	-	-	-	-	100	-
Veh in Median Storage, #	0	-	0	-	-	0
Grade, %	0	-	0	-	-	0
Peak Hour Factor	100	100	100	100	100	100
Heavy Vehicles, %	2	2	2	2	2	2
Mvmt Flow	21	21	927	37	37	214

Major/Minor	Minor1		Major1		Major2	
Conflicting Flow All	1236	950	0	0	966	0
Stage 1	948	-	-	-	-	-
Stage 2	288	-	-	-	-	-
Critical Hdwy	6.42	6.22	-	-	4.12	-
Critical Hdwy Stg 1	5.42	-	-	-	-	-
Critical Hdwy Stg 2	5.42	-	-	-	-	-
Follow-up Hdwy	3.518	3.318	-	-	2.218	-
Pot Cap-1 Maneuver	195	315	-	-	713	-
Stage 1	377	-	-	-	-	-
Stage 2	761	-	-	-	-	-
Platoon blocked, %			-	-		
Mov Cap-1 Maneuver	185	314	-	-	712	-
Mov Cap-2 Maneuver	185	-	-	-	-	-
Stage 1	376	-	-	-	-	-
Stage 2	721	-	-	-	-	-

Approach	WB		NB		SB
HCM Control Delay, s	23.8		0		1.5
HCM LOS	C				

Minor Lane/Major Mvmt	NBT	NBRWBLn1	SBL	SBT
Capacity (veh/h)	-	-	233	712
HCM Lane V/C Ratio	-	-	0.18	0.052
HCM Control Delay (s)	-	-	23.8	10.3
HCM Lane LOS	-	-	C	B
HCM 95th %tile Q(veh)	-	-	0.6	0.2

HCM 2010 Signalized Intersection Summary  
42: Mountain Boulevard & Creekside Pkwy

								
Movement	WBL	WBR	NBT	NBR	SBL	SBT		
Lane Configurations								
Traffic Volume (veh/h)	125	169	795	43	80	155		
Future Volume (veh/h)	125	169	795	43	80	155		
Number	3	18	2	12	1	6		
Initial Q (Qb), veh	0	0	0	0	0	0		
Ped-Bike Adj(A_pbT)	1.00	1.00		1.00	1.00			
Parking Bus, Adj	1.00	1.00	1.00	1.00	1.00	1.00		
Adj Sat Flow, veh/h/ln	1863	1863	1863	1900	1863	1863		
Adj Flow Rate, veh/h	125	138	795	43	80	155		
Adj No. of Lanes	1	1	2	0	1	1		
Peak Hour Factor	1.00	1.00	1.00	1.00	1.00	1.00		
Percent Heavy Veh, %	2	2	2	2	2	2		
Cap, veh/h	248	222	1418	77	106	1124		
Arrive On Green	0.14	0.14	0.42	0.42	0.06	0.60		
Sat Flow, veh/h	1774	1583	3508	185	1774	1863		
Grp Volume(v), veh/h	125	138	412	426	80	155		
Grp Sat Flow(s),veh/h/ln	1774	1583	1770	1830	1774	1863		
Q Serve(g_s), s	2.5	3.2	6.9	6.9	1.7	1.4		
Cycle Q Clear(g_c), s	2.5	3.2	6.9	6.9	1.7	1.4		
Prop In Lane	1.00	1.00		0.10	1.00			
Lane Grp Cap(c), veh/h	248	222	735	760	106	1124		
V/C Ratio(X)	0.50	0.62	0.56	0.56	0.76	0.14		
Avail Cap(c_a), veh/h	729	651	2454	2538	228	3062		
HCM Platoon Ratio	1.00	1.00	1.00	1.00	1.00	1.00		
Upstream Filter(I)	1.00	1.00	1.00	1.00	1.00	1.00		
Uniform Delay (d), s/veh	15.5	15.8	8.7	8.7	18.0	3.3		
Incr Delay (d2), s/veh	1.6	2.8	0.7	0.7	10.5	0.1		
Initial Q Delay(d3),s/veh	0.0	0.0	0.0	0.0	0.0	0.0		
%ile BackOfQ(50%),veh/ln	1.3	1.6	3.5	3.6	1.2	0.7		
LnGrp Delay(d),s/veh	17.1	18.6	9.3	9.3	28.6	3.4		
LnGrp LOS	B	B	A	A	C	A		
Approach Vol, veh/h	263		838			235		
Approach Delay, s/veh	17.9		9.3			12.0		
Approach LOS	B		A			B		
Timer	1	2	3	4	5	6	7	8
Assigned Phs	1	2				6		8
Phs Duration (G+Y+Rc), s	7.3	21.2				28.5		10.5
Change Period (Y+Rc), s	5.0	5.0				5.0		5.0
Max Green Setting (Gmax), s	5.0	54.0				64.0		16.0
Max Q Clear Time (g_c+I1), s	3.7	8.9				3.4		5.2
Green Ext Time (p_c), s	0.0	7.3				7.4		0.6
<b>Intersection Summary</b>								
HCM 2010 Ctrl Delay			11.5					
HCM 2010 LOS			B					

**Intersection**

Int Delay, s/veh 3.6












Movement	WBL	WBR	NBT	NBR	SBL	SBT
Lane Configurations	Y		P		T	T
Traffic Vol, veh/h	87	86	268	96	56	369
Future Vol, veh/h	87	86	268	96	56	369
Conflicting Peds, #/hr	0	0	0	0	0	0
Sign Control	Stop	Stop	Free	Free	Free	Free
RT Channelized	-	None	-	None	-	None
Storage Length	-	-	-	-	100	-
Veh in Median Storage, #	0	-	0	-	-	0
Grade, %	0	-	0	-	-	0
Peak Hour Factor	100	100	100	100	100	100
Heavy Vehicles, %	2	2	2	2	2	2
Mvmt Flow	87	86	268	96	56	369

Major/Minor	Minor1		Major1		Major2	
Conflicting Flow All	797	316	0	0	364	0
Stage 1	316	-	-	-	-	-
Stage 2	481	-	-	-	-	-
Critical Hdwy	6.42	6.22	-	-	4.12	-
Critical Hdwy Stg 1	5.42	-	-	-	-	-
Critical Hdwy Stg 2	5.42	-	-	-	-	-
Follow-up Hdwy	3.518	3.318	-	-	2.218	-
Pot Cap-1 Maneuver	356	724	-	-	1195	-
Stage 1	739	-	-	-	-	-
Stage 2	622	-	-	-	-	-
Platoon blocked, %			-	-		
Mov Cap-1 Maneuver	339	724	-	-	1195	-
Mov Cap-2 Maneuver	339	-	-	-	-	-
Stage 1	739	-	-	-	-	-
Stage 2	593	-	-	-	-	-

Approach	WB		NB		SB
HCM Control Delay, s	17.4		0		1.1
HCM LOS	C				

Minor Lane/Major Mvmt	NBT	NBRWBLn1	SBL	SBT
Capacity (veh/h)	-	-	461	1195
HCM Lane V/C Ratio	-	-	0.375	0.047
HCM Control Delay (s)	-	-	17.4	8.2
HCM Lane LOS	-	-	C	A
HCM 95th %tile Q(veh)	-	-	1.7	0.1

HCM 2010 Signalized Intersection Summary  
 42: Mountain Boulevard & Creekside Pkwy

								
Movement	WBL	WBR	NBT	NBR	SBL	SBT		
Lane Configurations								
Traffic Volume (veh/h)	77	113	251	24	212	244		
Future Volume (veh/h)	77	113	251	24	212	244		
Number	3	18	2	12	1	6		
Initial Q (Qb), veh	0	0	0	0	0	0		
Ped-Bike Adj(A_pbT)	1.00	1.00		1.00	1.00			
Parking Bus, Adj	1.00	1.00	1.00	1.00	1.00	1.00		
Adj Sat Flow, veh/h/ln	1863	1863	1863	1900	1863	1863		
Adj Flow Rate, veh/h	77	105	251	22	212	244		
Adj No. of Lanes	1	1	2	0	1	1		
Peak Hour Factor	1.00	1.00	1.00	1.00	1.00	1.00		
Percent Heavy Veh, %	2	2	2	2	2	2		
Cap, veh/h	200	178	757	66	291	1040		
Arrive On Green	0.11	0.11	0.23	0.23	0.16	0.56		
Sat Flow, veh/h	1774	1583	3388	287	1774	1863		
Grp Volume(v), veh/h	77	105	134	139	212	244		
Grp Sat Flow(s),veh/h/ln	1774	1583	1770	1812	1774	1863		
Q Serve(g_s), s	1.2	1.9	1.9	1.9	3.4	2.0		
Cycle Q Clear(g_c), s	1.2	1.9	1.9	1.9	3.4	2.0		
Prop In Lane	1.00	1.00		0.16	1.00			
Lane Grp Cap(c), veh/h	200	178	406	416	291	1040		
V/C Ratio(X)	0.39	0.59	0.33	0.33	0.73	0.23		
Avail Cap(c_a), veh/h	1109	990	1805	1849	1459	3739		
HCM Platoon Ratio	1.00	1.00	1.00	1.00	1.00	1.00		
Upstream Filter(I)	1.00	1.00	1.00	1.00	1.00	1.00		
Uniform Delay (d), s/veh	12.5	12.8	9.8	9.8	12.1	3.4		
Incr Delay (d2), s/veh	1.2	3.1	0.5	0.5	3.5	0.1		
Initial Q Delay(d3),s/veh	0.0	0.0	0.0	0.0	0.0	0.0		
%ile BackOfQ(50%),veh/ln	0.7	1.0	1.0	1.0	1.9	1.0		
LnGrp Delay(d),s/veh	13.7	15.9	10.2	10.2	15.5	3.5		
LnGrp LOS	B	B	B	B	B	A		
Approach Vol, veh/h	182		273			456		
Approach Delay, s/veh	15.0		10.2			9.1		
Approach LOS	B		B			A		
Timer	1	2	3	4	5	6	7	8
Assigned Phs	1	2				6		8
Phs Duration (G+Y+Rc), s	10.0	12.0				22.0		8.4
Change Period (Y+Rc), s	5.0	5.0				5.0		5.0
Max Green Setting (Gmax), s	25.0	31.0				61.0		19.0
Max Q Clear Time (g_c+I1), s	5.4	3.9				4.0		3.9
Green Ext Time (p_c), s	0.5	3.0				3.2		0.4
<b>Intersection Summary</b>								
HCM 2010 Ctrl Delay			10.6					
HCM 2010 LOS			B					

**APPENDIX C: SIGNAL WARRANT ANALYSIS WORKSHEETS**



Major Street **Mountain Boulevard**  
 Minor Street **Retail Village Driveway**

Project **Oak Knoll - January 2017 Results**  
 Scenario **2040 Plus Project**  
 Peak Hour **AM**

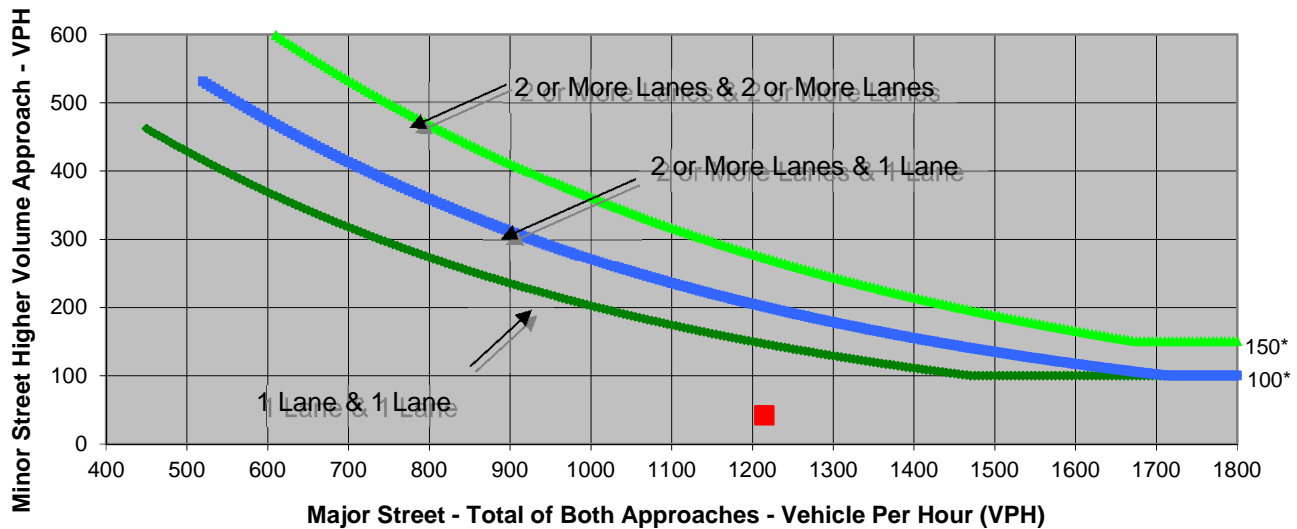
Turn Movement Volumes

	NB	SB	EB	WB
Left	0	37	0	21
Through	927	214	0	0
Right	37	0	0	21
Total	964	251	0	42

Major Street Direction

<b>x</b>	North/South
	East/West

**Figure 4C-3. Warrant 3, Peak Hour**



\* Note: 150 vph applies as the lower threshold volume for a minor-street approach with two or more lanes and 100 vph applies as the lower threshold volume for a minor-street approach with one lane.

Source: California Manual on Uniform Traffic Control Devices, Caltrans, 2014

	<b>Major Street</b> Mountain Boulevard	<b>Minor Street</b> Retail Village Driveway	<b>Warrant Met</b>
<b>Number of Approach Lanes</b>	<b>1</b>	<b>1</b>	<b><u>NO</u></b>
<b>Traffic Volume (VPH) *</b>	<b>1,215</b>	<b>42</b>	
* Note: Traffic Volume for Major Street is Total Volume of Both Approaches. Traffic Volume for Minor Street is the Volume of High Volume Approach.			



Major Street **Mountain Boulevard**  
 Minor Street **Retail Village Driveway**

Project **Oak Knoll - January 2017 Results**  
 Scenario **2040 Plus Project**  
 Peak Hour **PM**

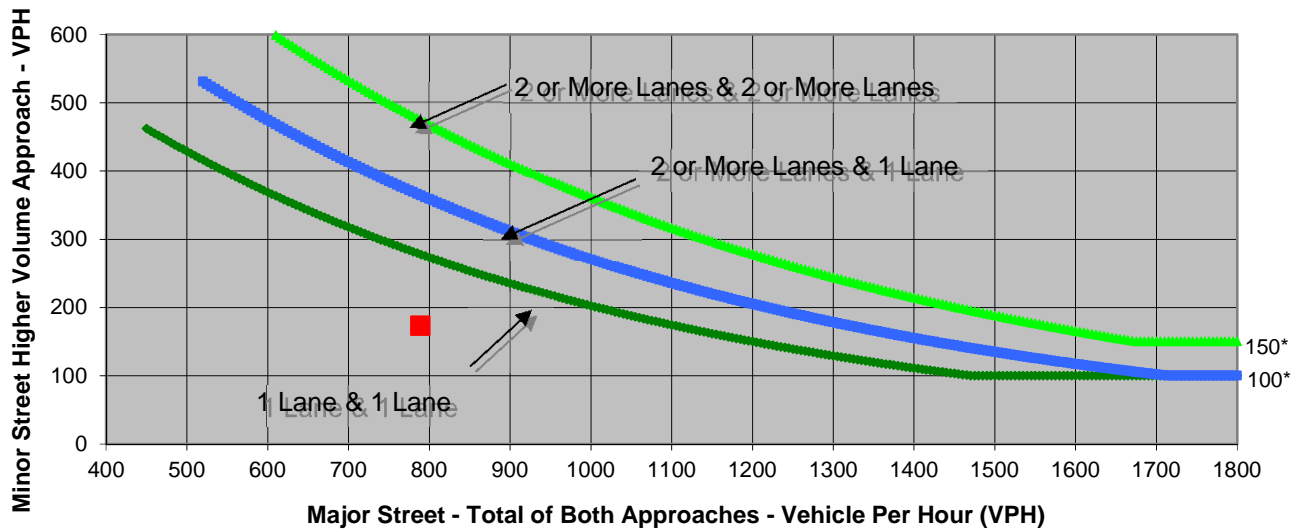
Turn Movement Volumes

	NB	SB	EB	WB
Left	0	56	0	87
Through	268	369	0	0
Right	96	0	0	86
Total	364	425	0	173

Major Street Direction

<b>x</b>	North/South
	East/West

**Figure 4C-3. Warrant 3, Peak Hour**



\* Note: 150 vph applies as the lower threshold volume for a minor-street approach with two or more lanes and 100 vph applies as the lower threshold volume for a minor-street approach with one lane.

Source: California Manual on Uniform Traffic Control Devices, Caltrans, 2014

	Major Street	Minor Street	Warrant Met
	Mountain Boulevard	Retail Village Driveway	
Number of Approach Lanes	<b>1</b>	<b>1</b>	<b><u>NO</u></b>
Traffic Volume (VPH) *	<b>789</b>	<b>173</b>	

\* Note: Traffic Volume for Major Street is Total Volume of Both Approaches.  
 Traffic Volume for Minor Street is the Volume of High Volume Approach.

Major Street **Mountain Boulevard**  
 Minor Street **Creekside Parkway**

Project **Oak Knoll - January 2017 Results**  
 Scenario **2040 Plus Project**  
 Peak Hour **AM**

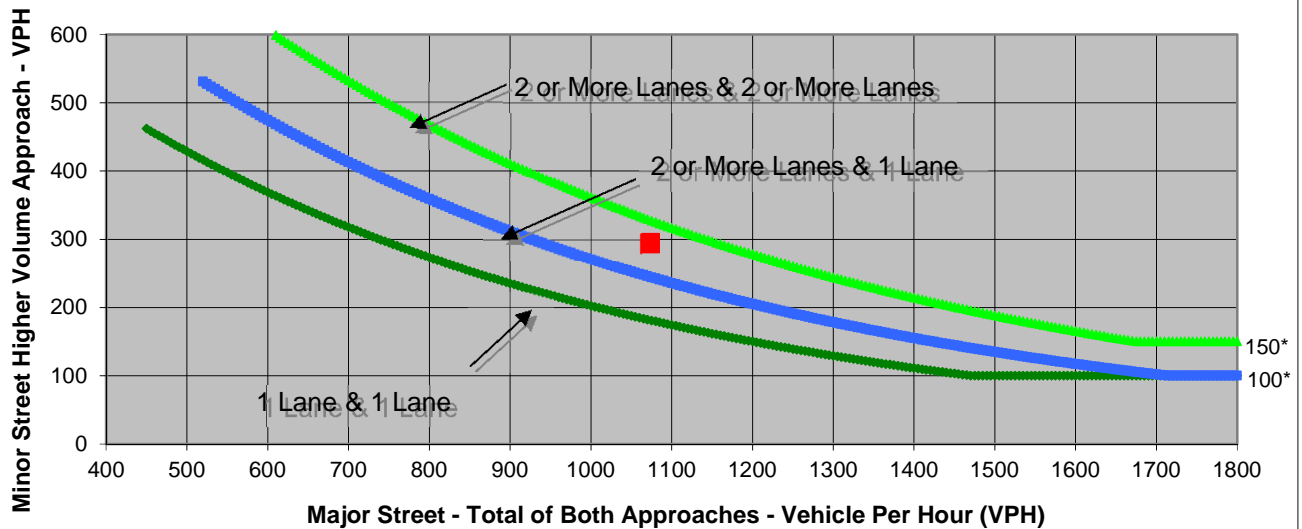
Turn Movement Volumes

	NB	SB	EB	WB
Left	0	80	0	125
Through	795	155	0	0
Right	43	0	0	169
Total	838	235	0	294

Major Street Direction

<b>x</b>	North/South
	East/West

**Figure 4C-3. Warrant 3, Peak Hour**



\* Note: 150 vph applies as the lower threshold volume for a minor-street approach with two or more lanes and 100 vph applies as the lower threshold volume for a minor-street approach with one lane.

Source: *California Manual on Uniform Traffic Control Devices*, Caltrans, 2014

	Major Street	Minor Street	Warrant Met
	Mountain Boulevard	Creekside Parkway	
<b>Number of Approach Lanes</b>	<b>1</b>	<b>1</b>	<b><u>YES</u></b>
<b>Traffic Volume (VPH) *</b>	<b>1,073</b>	<b>294</b>	
* Note: Traffic Volume for Major Street is Total Volume of Both Approaches. Traffic Volume for Minor Street is the Volume of High Volume Approach.			

Major Street **Mountain Boulevard**  
 Minor Street **Creekside Parkway**

Project **Oak Knoll - January 2017 Results**  
 Scenario **2040 Plus Project**  
 Peak Hour **PM**

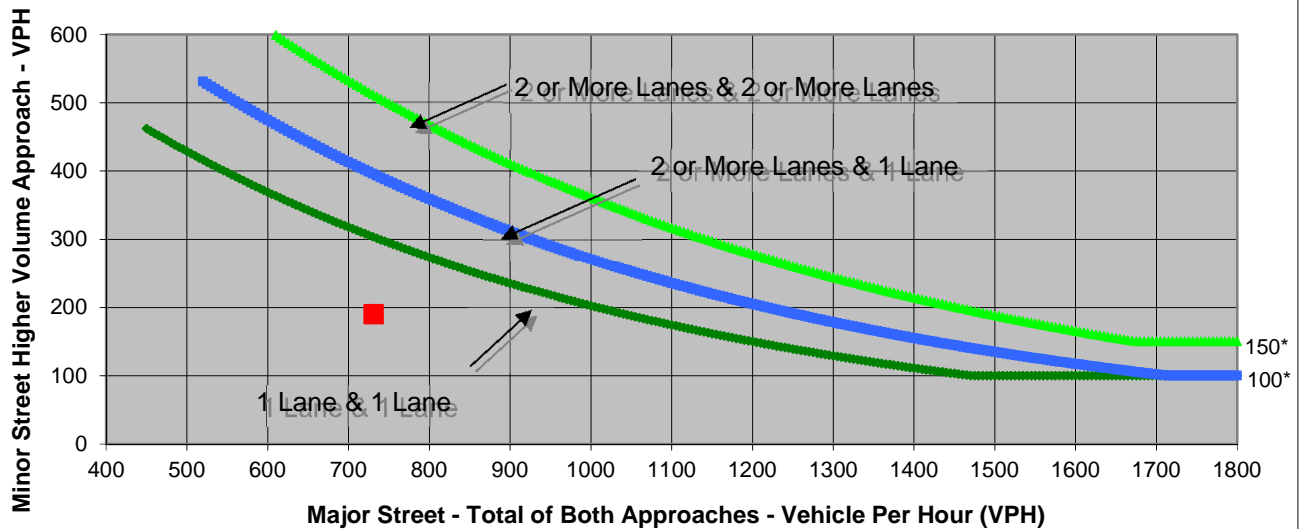
Turn Movement Volumes

	NB	SB	EB	WB
Left	0	212	0	77
Through	251	244	0	0
Right	24	0	0	113
Total	275	456	0	190

Major Street Direction

<b>x</b>	North/South
	East/West

**Figure 4C-3. Warrant 3, Peak Hour**



\* Note: 150 vph applies as the lower threshold volume for a minor-street approach with two or more lanes and 100 vph applies as the lower threshold volume for a minor-street approach with one lane.

Source: California Manual on Uniform Traffic Control Devices, Caltrans, 2014

	Major Street	Minor Street	Warrant Met
	Mountain Boulevard	Creekside Parkway	
Number of Approach Lanes	<b>1</b>	<b>1</b>	<b><u>NO</u></b>
Traffic Volume (VPH) *	<b>731</b>	<b>190</b>	

\* Note: Traffic Volume for Major Street is Total Volume of Both Approaches.  
 Traffic Volume for Minor Street is the Volume of High Volume Approach.

**Appendix B**  
Updated D-OK Oak Knoll  
District Zones Regulations  
and Map

# Proposed Oak Knoll Zoning District (D-OK)

ZONING LEGEND		
Key	Zone	Use
D-OK-1	Residential OK-1	Low Density
D-OK-2	Residential OK-2	Medium-Low Density
D-OK-3	Residential OK-3	Medium Density
D-OK-4	Commercial	Village Retail
D-OK-5	Community Commercial	Community Use and Limited Commercial
D-OK-6	Active Open Space	Active Recreation and Park Uses
D-OK-7	Passive Open Space	Creek, Natural Features, Hiking, and Buffers

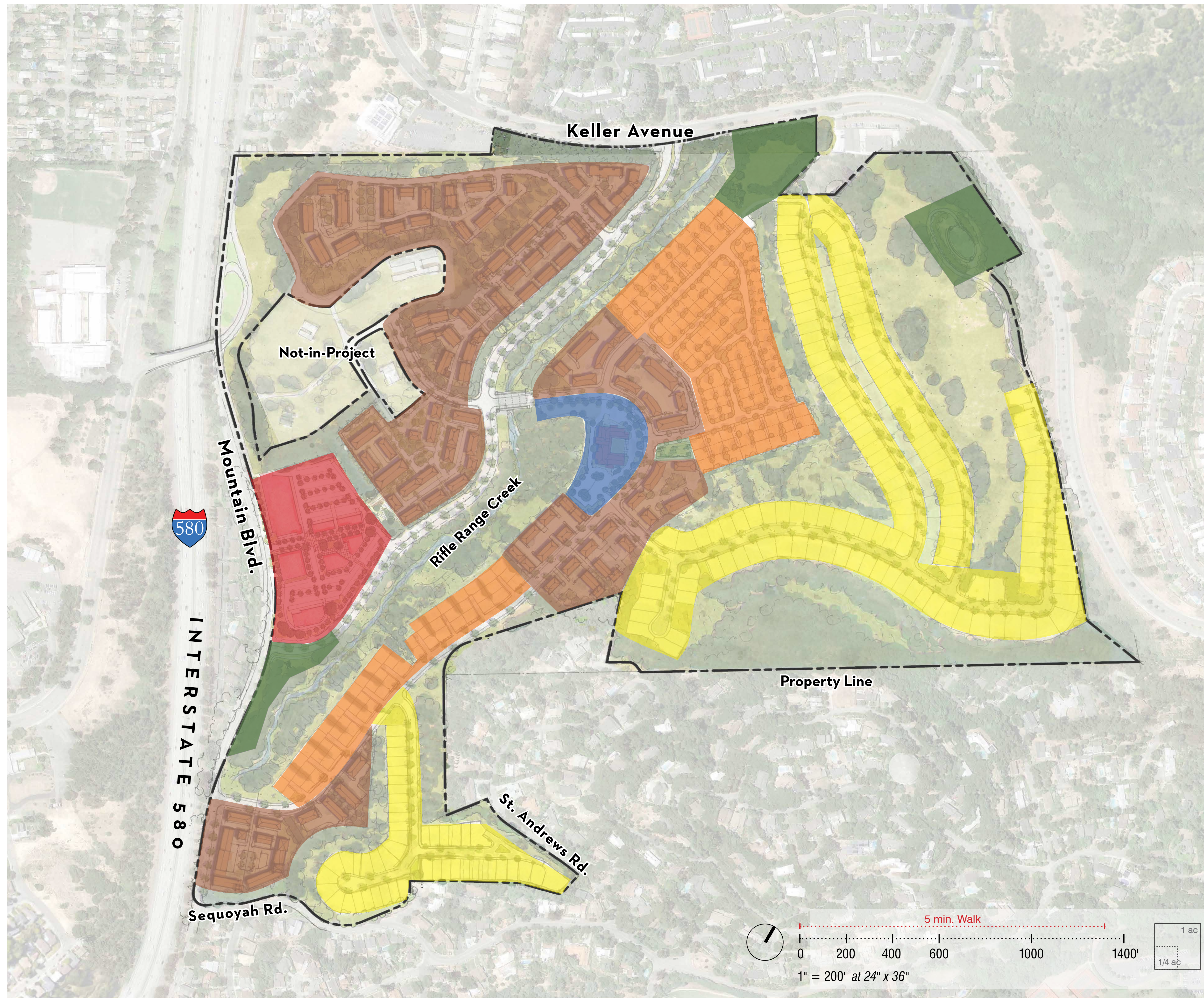


Figure 4  
Proposed Oak Knoll Zoning District  
January 23, 2017

## Chapter 17.101J - D-OK OAK KNOLL DISTRICT ZONES REGULATIONS

### Sections:

17.101J.010 - Title, intent, and description.

17.101J.020 - Required design review process, including preliminary and final development plan approval and Oak Knoll Design Guidelines.

17.101J.030 - Permitted and conditionally permitted activities.

17.101J.040 - Permitted and conditionally permitted facilities.

17.101J.050 - Property development standards.

17.101J.060 - Subdivision.

17.101J.070 - Conditional use permit criteria.

17.101J.080 - Other zoning provisions.

17.101J.090 – Definitions

### 17.101J.010 - Title, intent, and description.

- A. Title and Intent. The provisions of this Chapter shall be known as the D-OK Oak Knoll District Zones Regulations. The intent of the Oak Knoll District (D-OK) Zones is to implement the Oak Knoll District Planned Unit Development (OKPUD) permit. The OKPUD intends to establish and maintain a pedestrian-oriented neighborhood that contains a mix of housing types, community amenities, a retail area, passive and active recreational opportunities, and open spaces. These regulations shall apply to the six (6) zoning districts (the D-OK zones) in the OKPUD area.
- B. Description of Zones. This Chapter establishes land use regulations for the following six zones:
1. **D-OK-1 Oak Knoll District Residential Zone - 1.** The D-OK-1 Zone is intended to create, maintain, and enhance areas suitable for low-density single-family home development that responds to the site's topography and includes appropriate landscaping.
  2. **D-OK-2 Oak Knoll District Residential Zone - 2.** The D-OK-2 Zone is intended to create, maintain, and enhance areas suitable for medium-low density single-family homes.
  3. **D-OK-3 Oak Knoll District Residential Zone - 3.** The D-OK-3 Zone is intended to create, maintain, and enhance areas suitable for medium-density residential units, such as townhomes.
  4. **D-OK-4 Oak Knoll District Commercial Zone - 4.** The D-OK-4 Zone is intended to create, maintain, and enhance areas that provide neighborhood-serving retail, such as supermarkets, banks, cafes, and dry-cleaners. Ground floor commercial uses and upper story office uses are encouraged in this zone.

5. **D-OK-5 Oak Knoll District Amenity Community Commercial Zone - 6.** The D-OK-6 Zone is intended to create, maintain, and enhance areas for community activities and commercial uses that provide a community amenity. Although this area is intended primarily to serve the community, spaces may be rented for non-community functions, including weddings and other organized events.
6. **D-OK-6 Oak Knoll District Active Open Space Zone – 6.** The D-OK-6 Zone is intended to create, maintain and enhance open space areas that provide opportunities for informal active recreation and park use. The programming of each individual open space will respond to its location and the needs of surrounding residents. This zone is appropriate for lawn and landscaped areas, tot lots, and street furniture, such as benches, tables, and ornamental fixtures.
7. **D-OK-7 Oak Knoll District Passive Open Space Zone - 7.** The D-OK-7 Zone is intended to create, maintain, and enhance open space areas that preserve natural features of the OKPUD area and provide opportunities for passive recreation and maintenance of visual buffers. The programming of each individual open space will respond to its location, natural resources, and topography. This zone is appropriate for management of vegetation and water features, hiking and walking trails, and enhancement of wildlife.

**17.101J.020 - Required Design Review Process, Including Preliminary and Final Development Plan Approval and Oak Knoll Design Guidelines.**

- A. All development within the Oak Knoll District is subject to an approved Planned Unit Development (PUD) permit pursuant to Chapters 17.140 and 17.142.
- B. Development within the District shall be consistent with the Oak Knoll Preliminary Development Plan (as it may be amended), in particular with the Oak Knoll Design Guidelines, which were adopted as part of the Preliminary Development Plan. Conformance to the Oak Knoll Design Guidelines is required for any change to the exterior of a building that requires a building permit in the Oak Knoll District.
- C. In addition, as applicable, development is subject to the following design review requirements:
  1. Original development of more than two lots at the same time shall require approval of, and be consistent with, a Final Development Plan in accordance with the procedures set forth in Chapter 17.140. For development requiring a Final Development Plan, a determination of consistency with the Final Development Plan shall take the place of, and be deemed equivalent to, the design review procedures in Chapter 17.136.
  2. Original development of two or fewer lots at the same time shall be subject to the design review procedures set forth in under 17.136.
  3. Subsequent approvals to existing development shall be subject to design review under Chapter 17.136, except where such projects are exempt from design review pursuant to Section 17.136.025. Where there is a conflict between the design review criteria contained in Section 17.136.070 and the design objectives contained in the Oak Knoll Design Guidelines, the design objectives in the Oak Knoll Design Guidelines shall prevail.
  4. Telecommunications facilities shall be subject to design review in accordance with Chapter 17.128 unless they have already been approved pursuant to a Final Development Plan.

5. Signs other than those covered by a Final Development Plan shall be subject to design review in accordance with Chapter 17.104.

**17.101J.030 - Permitted and conditionally permitted activities.**

Table 17.101J.01 lists the permitted, conditionally permitted, and prohibited activities in the D-OK Zones. The descriptions of these activities are contained in Chapter 17.10. Section 17.10.040 contains permitted accessory activities.

"P" designates permitted activities in the corresponding zone.

"C" designates activities that are permitted only upon the granting of a Conditional Use permit (CUP) in the corresponding zone (see Chapter 17.134 and Section 17.101J.070 for the CUP procedure and criteria).

"L" designates activities subject to certain limitations or notes listed at the bottom of the table.

"—" designates activities that are prohibited except as accessory activities according to the regulations contained in Section 17.010.040.

**Table 17.101J.01: Permitted and Conditionally Permitted Activities**

Activities	Primary Zones							Additional Regulations
	D-OK-1	D-OK-2	D-OK-3	D-OK-4	D-OK-5	D-OK-6	D-OK-7	
<b>Residential Activities</b>								
Permanent	P	P	P	—	—	—	—	
Residential Care	P(L1)	P(L1)	P(L1)	—	—	—	—	17.103.010
Supportive Housing	P	P	P	—	—	—	—	
Transitional Housing	P	P	P	—	—	—	—	
Emergency Shelter	—	—	—	—	C(L1) (L2)	—	—	17.103.010
Semi-Transient	—	—	—	—	—	—	—	
Bed and Breakfast	—	—	—	—	—	—	—	



<b>Civic Activities</b>								
Essential Service	P	P	P	P	P	P	P	
Limited Child-Care Activities	P	P	P	P	P	—	—	
Community Assembly	C	C	C	C	P	P(L3)	—	
Recreational Assembly	C	C	C	P	C	P(L4)	—	
Community Education	C	C	C	C	C	—	—	
Nonassembly Cultural	C	C	C	P	P	—	—	
Administrative	—	—	—	P	P	—	—	
Health Care	—	—	—	C(L5)	P(L6)	—	—	
Special Health Care	—	—	—	—	—	—	—	17.103.020
Utility and Vehicular	C	C	C	C	—	—	—	
Extensive Impact	—	—	—	—	—	—	—	
<b>Commercial Activities</b>								
General Food Sales	—	—	—	P	P(L7)	—	—	
Full Service Restaurants	—	—	—	P	C	—	—	
Limited Service Restaurant and Cafe	—	—	—	P	P(L7)	—	—	

Fast-Food Restaurant	—	—	—	—	—	—	—	17.103.030 and 8.09
Convenience Market	—	—	—	C	—	—	—	17.103.030
Alcoholic Beverage Sales	—	—	—	C	C	—	—	17.103.030, and 17.114.030,
Mechanical or Electronic Games	—	—	—	--	—	—	—	
Medical Service	—	—	—	P(L7)	—	—	—	
General Retail Sales	—	—	—	P	P(L7)	—	—	
Large-Scale Combined Retail and Grocery Sales	—	—	—	—	—	—	—	
Consumer Service	—	—	—	P(L8) (L9)	—	—	—	
Consultative and Financial Service	—	—	—	P	—	—	—	
Check Cashier and Check Cashing	—	—	—	—	—	—	—	
Consumer Cleaning and Repair Service	—	—	—	P(L9)	—	—	—	
Consumer Dry Cleaning Plant	—	—	—	—	—	—	—	
Group Assembly	—	—	—	C	P	—	—	

Personal Instruction and Improvement Services	—	—	—	P	P	—	—	
Administrative	—	—	—	P(L10)	P	—	—	
Business, Communication, and Media Services	—	—	—	P(L11)	—	—	—	
Broadcasting and Recording Services	—	—	—	—	—	—	—	
Research Service	—	—	—	C(L11)	—	—	—	
General Wholesale Sales	—	—	—	—	—	—	—	
Transient Habitation	—	—	—	—	—	—	—	17.103.050
Building Material Sales	—	—	—	—	—	—	—	
Automobile and Other Light Vehicle Sales and Rental	—	—	—	—	—	—	—	
Automobile and Other Light Vehicle Gas Station and Servicing	—	—	—	—	—	—	—	
Automobile and Other Light	—	—	—	—	—	—	—	

Vehicle Repair and Cleaning								
Taxi and Light Fleet-Based Services	—	—	—	—	—	—	—	
Automotive Fee Parking	—	—	—	—	—	—	—	
Animal Boarding	—	—	—	C	—	—	—	
Animal Care	—	—	—	P	—	—	—	
Undertaking Service	—	—	—	—	—	—	—	
<b>Industrial Activities</b>								
Custom Manufacturing	—	—	—	P	P(L12)	—	—	17.120
Light Manufacturing	—	—	—	—	—	—	—	
General Manufacturing	—	—	—	—	—	—	—	
Heavy/High Impact	—	—	—	—	—	—	—	
Research and Development	—	—	—	—	—	—	—	
Construction Operations	—	—	—	—	—	—	—	
<b>Warehousing, Storage, and Distribution-Related</b>								
Warehousing, Storage, and Distribution-	—	—	—	—	—	—	—	

Related (all categories)								
<b>Recycling and Waste-Related</b>								
Recycling and Waste-Related (all categories)	—	—	—	—	—	—	—	
<b>Agriculture and Extractive Activities</b>								
Limited Agriculture	—	—	P(L13) (L14)	P(L13) (L14)	P(L13) (L14)	P(L13) (L14)	P(L13) (L14)	
Extensive Agriculture	—	—	—	—	—	—	—	
Plant Nursery	—	—	—	—	—	—	—	
Mining and Quarrying	—	—	—	—	—	—	—	

**Limitations on Table 17.101J.01:**

**L1.** Residential Care is only permitted in a One-Family Dwelling Residential Facility. No Residential Care or Emergency Shelter Residential Activity shall be located closer than three hundred (300) feet from any other such Activity or Facility. See Section 17.103.010 for other regulations regarding Residential Care and Emergency Shelter Residential Activities.

**L2.** An Emergency Shelter Residential Activity is limited to the temporary housing of displaced people after a catastrophe, including earthquake, fire, flood, or other similar act of God, that makes residences uninhabitable. All other types of Emergency Shelter Residential Activities are prohibited.

**L3.** Community Assembly Civic Activities are allowed only in accordance with the requirements in Section 17.11.060 for parks designated Neighborhood Park (NP). Where Section 17.11.060 is inconsistent with Note L4, below, Note L4 controls.

**L4.** The following Recreational Assembly Civic Activities are permitted: playgrounds and playing fields; basketball courts, tennis courts, handball courts, lawn bowling, leisure areas, and similar outdoor park and recreational facilities; picnic areas; community gardens; dog run areas; and uses accessory to these permitted uses. The following Recreational Assembly Civic Activities are conditionally permitted: food service and other concessions; temporary nonprofit festivals; community outdoor swimming and wading pools, and other water play features; and permanent bleacher seating and outdoor field lighting.

**L5.** In addition to the Conditional Use Permit (CUP) criteria required under Section 17.134.050, as modified by Section 17.101J.070, the following additional criteria also must be met:

1. That the proposal will not interfere with the operations of the surrounding uses;
2. That the proposal will not exceed 5,000 square feet on the ground floor; and
3. That the proposal will not interfere with the movement of people along the sidewalk or pedestrian walkways.

**L6.** Temporary health clinics, including clinics for flu shots, vaccinations, eye health screening, and other similar activities, and temporary blood drives, are permitted. As used in Note L6, “temporary” means an event that lasts no longer than seven days. All other Health Care Civic Activities are prohibited.

**L7.** The total floor area devoted to these activities is limited to 5,000 square feet.

**L8.** See Section 17.102.170 for special regulations relating to massage services. Also, no new or expanded laundromat shall be located closer than five hundred (500) feet from any existing laundromat. See Section 17.102.450 for further regulations regarding laundromats.

**L9.** The total floor area devoted to these activities on the ground floor by any single establishment may only exceed five thousand (5,000) square feet upon the granting of a Conditional Use Permit (see Chapter 17.134 and Section 17.101J.070 for the CUP procedure and criteria).

**L10.** The total floor area devoted to Administrative Activities is limited to 5,000 square feet if located on the ground floor. There is no size limitation for such uses if not located on the ground floor.

**L11.** Except for media services, these activities are not permitted if located on the ground floor of a building.

**L12.** In areas with existing kitchen facilities, Custom Manufacturing Activities that require a kitchen, such as beverage and food production, are permitted. Temporary demonstrations, educational programs, and workshops about any custom manufacturing activity are permitted. The permanent establishment of Custom Manufacturing Activities that do not require kitchens or in any area that does not contain existing kitchen facilities requires a Major Conditional Use Permit.

**L13.** Other than Community Gardens (see Note L14), Limited Agriculture is only permitted upon the granting of a Conditional Use Permit (see Chapter 17.134 and Section 17.101J.070 for the CUP procedure and criteria). In addition to the CUP criteria contained in Section 17.134.050 and Section 17.101J.070, this activity must meet the following use permit criteria:

1. The proposal will not adversely affect the livability or appropriate development of abutting properties and the surrounding neighborhood in terms of noise, water and pesticide runoff, farming equipment operation, hours of operation, odor, security, and vehicular traffic;
2. Agricultural chemicals or pesticides will not impact abutting properties or the surrounding neighborhood; and
3. The soil used in growing does not contain any harmful contaminants and the activity will not create contaminated soil.

**L14.** Community Gardens are permitted by right if they do not include the cultivation of animals, animal products, and/or livestock production, except for bee keeping involving no more than three (3) hives. The cultivation of animals, animal products and/or livestock production, except for bee

keeping involving no more than three (3) hives, is only permitted upon the granting of a Conditional Use Permit (see Chapter 17.134 and Section 17.101J.070 for the CUP procedure and criteria).

**17.101J.040 - Permitted and conditionally permitted facilities.**

Table 17.101J.02 lists the permitted, conditionally permitted, and prohibited facilities in the D-OK Zones. The descriptions of these facilities are contained in Chapter 17.10.

"P" designates permitted facilities in the corresponding zone.

"C" designates facilities that are permitted only upon the granting of a Conditional Use Permit (CUP) in the corresponding zone (see Chapter 17.134 and Section 17.101J.070 for the CUP procedure and criteria).

"L" designates facilities subject to certain limitations listed at the bottom of the Table.

"—" designates facilities that are prohibited.

**Table 17.101J.02: Permitted and Conditionally Permitted Facilities**

Facilities	Zones							Additional Regulations
	D-OK-1	D-OK-2	D-OK-3	D-OK-4	D-OK-5	D-OK-6	D-OK-7	
<b>Residential Facilities</b>								
One-Family Dwelling	P	P	C	—	—	—	—	
One-Family Dwelling with Secondary Unit	P	P	C	—	—	—	—	17.103.080
Two-Family Dwelling	—	—	P	—	—	—	—	
Multifamily Dwelling	—	—	P	—	—	—	—	
Rooming House	—	—	—	—	—	—	—	
Mobile Home	—	—	—	—	—	—	—	
<b>Nonresidential Facilities</b>								
Enclosed Nonresidential	—	—	—	P	P	C	—	
Open Nonresidential	P	P	P	C	C	P	P	
Sidewalk Cafe	—	—	—	P(L1)	—	—	—	17.103.090
Drive-In	—	—	—	—	—	—	—	

Drive-Through	—	—	—	P(L2)	—	—	—	17.103.100
<b>Telecommunications Facilities</b>								
Micro Tele-communications	C	C	C	C	C	C	C	17.128
Mini Tele-communications	C	C	C	C	C	C	C	17.128
Macro Tele-communications	C	C	C	C	C	C	C	17.128
Monopole Tele-communications	C	C	C	C	C	C	C	17.128
Tower Tele-communications	C	C	C	C	C	C	C	17.128
<b>Sign Facilities</b>								
Residential Signs	P(L3)	P(L3)	P(L3)	—	—	—	—	
Special Signs	P(L3)	P(L3)	P(L3)	P(L4)	P(L3)	P(L3)	—	
Development Signs	P(L3)	P(L3)	P(L3)	P(L4)	P(L3)	—	—	
Realty Signs	P(L3)	P(L3)	P(L3)	P(L4)	P(L3)	—	—	
Civic Signs	P(L3)	P(L3)	P(L3)	P(L4)	P(L3)	C(L3)	—	
Business Signs	—	—	—	P(L4)	P(L3)	—	—	
Advertising Signs	—	—	—	—	—	—	—	

L1. Sidewalk cafes are allowed only as an accessory facility to an approved Full Service Restaurant or Limited Service Restaurant and Cafe. The sidewalk cafe may only operate within the hours of 7:00 a.m. to 10:30 p.m. See Section 17.103.090 for other regulations regarding Sidewalk Cafes; however, the regulations in this Section supersede any contradicting regulations in Section 17.103.090.

L2. Drive-through facilities are permitted for pharmacy and retail banking uses only. Drive-through facilities are prohibited for all other uses.

L3. All signs other than monument signs, which are defined in the OKPUD, shall comply with the regulations in Section 17.104.010. Monument signs shall comply with the regulations in Section 17.101J.020 and the OKPUD.

L4. Signs shall comply with the regulations in Section 17.101J.020, 17.104.020, or 17.104.070, as applicable.



**17.101J.050 - Property development standards.**

**A. Zone Specific Standards.** Table 17.101J.03 below prescribes development standards specific to individual zones. The number designations in the "Additional Regulations" column refer to the regulations listed at the end of the Table. "—" indicates that a standard is not required in the specified zone.

Table 17.101J.03: Property Development Standards

Development Standards	Zones							Additional Regulations
	D-OK-1	D-OK-2	D-OK-3	D-OK-4	D-OK-5	D-OK-6	D-OK-7	
<b>Minimum Lot Dimensions</b>								
Width mean	42 ft.	40 ft.	20 ft.	25 ft.	25 ft.	20 ft.	N/A	1
Frontage	25 ft.	25 ft.	20 ft.	25 ft.	25 ft.	20 ft.	N/A	2
Lot area	3,750 sf.	2,000 sf.	5,000 sf.	4,000 sf.	4,000 sf.	2,000 sf.	N/A	
<b>Minimum/Maximum Setbacks</b>								
Minimum Front	15 ft./5 ft.	8 ft.	8 ft.	0 ft.	20 ft.	8 ft.	N/A	3, 4, 5, 6, 10
Minimum Interior Side	4 ft./5 ft.	3 ft. per side or a total of 5 ft.	4 ft.	0 ft./5 ft.	20 ft.	4 ft.	N/A	7, 8, 10
Minimum Street Side	5 ft.	5 ft.	5 ft.	0 ft.	20 ft.	0 ft.	N/A	10
Rear	15 ft.	12 ft.	N/A	0 ft./5 ft.	20 ft.	0 ft.	N/A	9, 10
<b>Maximum Density</b>								
Permitted Density	1 primary unit per lot	1 primary unit per lot	1 unit per 1,600 sf. of lot area on lots 5,000 sf. or greater	0.50 FAR	0.50 FAR	0.15 FAR	N/A	11
Maximum FAR for Lots with a	0.65	N/A	N/A	N/A	N/A	N/A	N/A	11

Footprint Slope >20%								
Maximum Lot Coverage (%)	50%	55%	55%	N/A	N/A	N/A	N/A	11
<b>Heights</b>								
Maximum wall height primary building	30 ft. and 2 stories	35 ft. and 3 stories	35 ft.	30 ft.	42 ft.	15 ft.	N/A	12
Maximum pitched roof height primary building	32 ft. and 2 stories	35 ft. and 3 stories	40 ft.	30 ft.	46 ft.	20 ft.	N/A	12
Maximum height for accessory structures	15 ft.	15 ft.	15 ft.	15 ft.	15 ft.	15 ft.	15 ft.	12
Height Regulations for all Lots with a Footprint Slope of > 20% or that are terraced or split	See Table 17.101J.04	N/A	N/A	N/A	N/A	N/A	N/A	
<b>Minimum Open Space</b>								
Group Open Space	N/A	N/A	170 sf. per unit	N/A	N/A	N/A	N/A	13
Courtyard Regulations	N/A	N/A	See Section 17.108.120	N/A	N/A	N/A	N/A	
<b>Other Development Standards</b>								
Parking and driveway location requirements	Yes	Yes	Yes	Yes	No	No	N/A	14

Ground floor active space requirement	N/A	N/A	N/A	Yes	N/A	N/A	N/A	15
Minimum ground floor façade glazing	N/A	N/A	N/A	40 to 70%	N/A	N/A	N/A	16
Minimum height of ground floor facilities	N/A	N/A	N/A	12 ft.	N/A	N/A	N/A	17
Minimum Required Parking	Yes	Yes	Yes	Yes	No	No	N/A	18

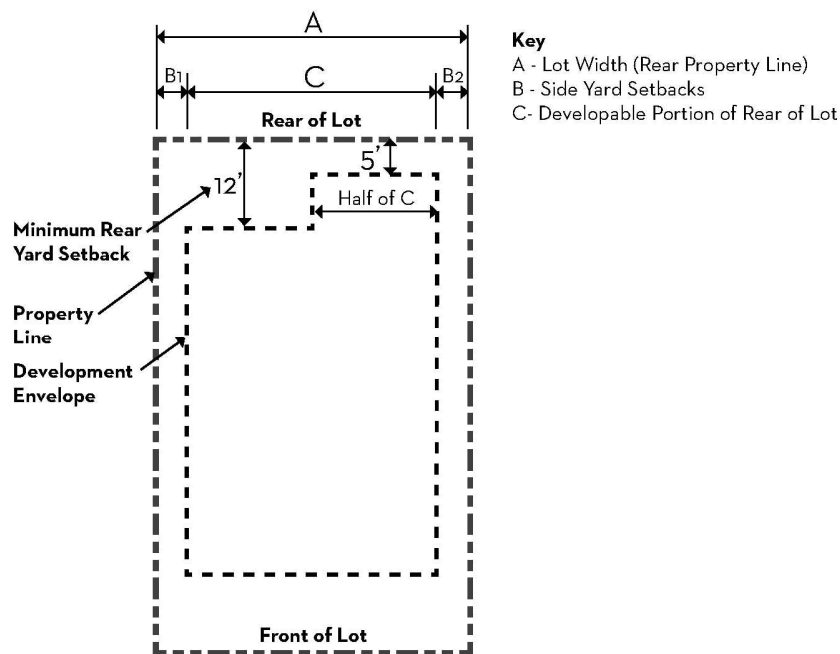
**Additional Regulations for Table 17.101J.03:**

1. No additional subdivisions other than what was approved in the OKPUD are permitted unless a new planned unit development (PUD) application is submitted pursuant to the procedures in Chapter 17.140.
2. The minimum frontage requirement does not apply to flag lots created as part of the original OKPUD.
3. For lots in the D-OK-1 Zone with a footprint slope of less than twenty (20) percent, the minimum front setback is fifteen (15) feet. For lots in the D-OK-1 Zone with a footprint slope equal to or greater than twenty (20) percent, the minimum front setback is five (5) feet.
4. For residences in the D-OK-2 Zone located off of a shared access facility, the minimum front setback is measured from the edge of the pavement of the common access drive.
5. The minimum front setback for a garage is eighteen (18) feet for lots in the D-OK-1 Zone with a footprint slope equal to or less than twenty (20) percent, and lots in the D-OK-3 Zone. In the D-OK-2 Zone, the minimum front setback for a garage is fifteen (15) feet. The minimum front setback for a garage is five (5) feet for lots in the D-OK-1 Zone with a footprint slope greater than twenty (20) percent.
6. In the D-OK-1, D-OK-2, and D-OK-3 Zones, covered porches are permitted in the front setback; in these zones, covered porches not exceeding one story and structures under 30 inches in height shall have a minimum front setback of three (3) feet. Stairs in these zones are permitted up to the front property line.
7. In the D-OK-2 Zone, the minimum interior side yard is three (3) feet except, for a single-family dwelling unit on a lot with two interior side yards, one of the two interior side yards can be reduced to zero (0) feet without a variance if the other interior side yard is at least five (5) feet. On the ground-floor, only a garage of a maximum length of twenty-four (24) feet is allowed on the interior side without a side yard. Habitable rooms are permitted over such a

garage. On the interior side without a side yard, no windows, doors or upper floor balconies or decks are permitted less than three (3) feet of the property line.

8. In the D-OK-1 Zone, the minimum interior side yard is four (4) feet on lots less than six thousand (6,000) square feet. The minimum interior side yard is five (5) feet on all other lots in the D-OK-1 Zone. In the D-OK-4 Zone, there is no minimum interior side yard setback unless the interior side lot line is adjacent to a Residential Zone, in which case the minimum side yard setback is five (5) feet.

9. In the D-OK-2 Zone, the minimum rear setback can be reduced to five (5) feet over a maximum of one-half (1/2) the width of the developable portion of the lot (i.e., the width not including the applicable side yard setbacks), as shown in the following figure. In the D-OK-4 Zone, there is no minimum rear setback unless the rear lot line is adjacent to a Residential Zone, in which case the rear setback is five (5) feet.



10. If there is any ambiguity regarding the required setbacks, the setbacks in the Oak Knoll Design Guidelines shall control.

11. Where a Secondary Unit is permitted in the D-OK Zones (i.e., on a residential lot with only one (1) single-family dwelling unit), the requirements in Section 17.103.080 shall apply.

12. See Section 17.108.030 for allowed projections above height limits and Section 17.108.020 for increased height limits for civic buildings. See Table 17.101J.04 for height regulations for all lots with a footprint slope exceeding twenty (20) percent, or that are terraced or split. In the D-OK-5 Zone, the maximum height is measured from the ground level of the building, and the tower of Club Knoll is an allowed projection above the height limit. Also in the D-OK-5 Zone, for any building other than Club Knoll or a replica of Club Knoll, the height limit is the same as in the D-OK-4 Zone.

13. The per unit Group Open Space requirement can be replaced by 70 square feet of dedicated Private Open Space per unit. All usable Group Open Space shall meet the

requirements in Sections 17.126.030.A through 17.126.030.E. Usable Private Open Space shall meet the following requirements:

- a. Usability. A surface shall be provided which prevents dust and allows convenient use for outdoor activities. Such surface shall be any practicable combination of lawn, garden, flagstone, wood planking, concrete, asphalt, or other serviceable, dust-free surfacing. Slope shall not exceed ten percent (10%). Off-street parking and loading areas, driveways, and service areas shall not be counted as usable open space. Adequate safety railings or other protective devices shall be erected wherever necessary for space on a roof or balcony, but shall not be more than the minimum height required by the Oakland Building Code.
- b. Location. The space may be located anywhere on the lot. Above-ground-level space may be counted even though it projects beyond a street line. All spaces shall be adjacent to, and not more than four (4) feet above or below the floor level of, the living unit served.
- c. Size and Shape. An area of contiguous ground-level space shall be of such size and shape that a rectangle inscribed within it shall have no dimension less than ten (10) feet. An area of above-ground-level space shall be of such size and shape that a rectangle inscribed within it shall have no dimension less than five (5) feet. When space is located on a roof, the area occupied by vents or other structures which do not enhance usability of the space shall not be counted toward the above dimension.
- d. Accessibility. The space shall be accessible to only one living unit by a doorway to a habitable room or hallway.
- e. Openness. There shall be no obstructions over ground-level space except for devices to enhance its usability and except that not more than fifty percent (50%) of the space may be covered by a private balcony projecting from a higher story. Above-ground-level space shall have at least one exterior side open and unobstructed, except for incidental railings or balustrades, for eight (8) feet above its floor level.

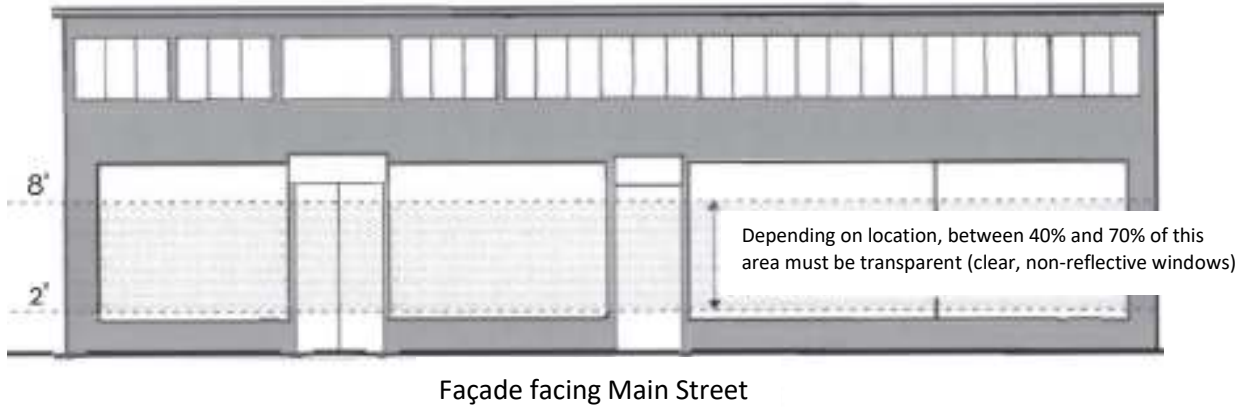
Enclosures and landscaping for both usable Group and Private Open Spaces must be consistent with the requirements in the Oak Knoll Design Guidelines.

**14.** In the D-OK District Residential Zones, Section 2.6 of the Oak Knoll Design Guidelines applies. Parking and loading requirements in the D-OK-4 Zone are the same as in the CN-4 Zone, subject to the exceptions stated in Note 15 below.

**15.** Locker areas, storage areas, mechanical rooms, and other non-active spaces shall not be located within thirty (30) feet from the front of the principal building except for incidental entrances to such activities elsewhere in the building. Exceptions to this regulation may be permitted by the Planning Director for utilities and trash enclosures that cannot be feasibly placed in other locations of the building. Driveways, garage entrances, or other access to parking and loading facilities may be located in front of the principal building, as regulated by Note 12 to Table 17.33.03 in Planning Code Section 17.33.050.A. "Street" parking is allowed along either the principal street or principal private driveway in front of the principal building. (An example of "street" parking is shown in Figure 1.5 in Chapter 2.3 of the Oak Knoll Design Guidelines.) Parking lots are not allowed in the front of the principal building.

**16.** The minimum percent transparency for the band between two (2) feet and eight (8) feet in height of any side of a commercial building facing a Principal Drive is forty (40) percent. The minimum percent transparency for the band between two (2) feet and eight (8) feet in

height of any side of a commercial building facing a retail plaza is seventy (70) percent. An example of glazing treatment that meets these requirements is illustrated in the figure below.



17. The minimum height requirement applies only for new principal buildings and the height is measured from the sidewalk grade to the ground floor ceiling.

18. In the D-OK-1, D-OK-2, and D-OK-3 Zones, the regulations in Sections 17.116.050, 17.116.060 and 17.116.070 for the RH and/or RD Zones apply. In the D-OK-4 Zone, the regulations in Sections 17.116.050, 17.116.070, 17.116.080, 17.116.090, and 17.116.140 for the CN Zone apply. In the D-OK-5 Zone, the regulations in Sections 17.116.050, 17.116.070, 17.116.080, and 17.116.090, and 17.116.130 for “any other zone” apply. In the D-OK-6 and D-OK-7 Zones, the regulations in Section 17.116.050 through 17.116.100 for the OS Zone apply.

**B. Height Standards for Sloped, Terraced, or Split Lots.** Table 17.101J.04 below prescribes the height standards associated with different sloped, terraced, or split lots. The numbers in the "Additional Regulations" column refer to the regulations listed at the end of the Table.

**Table 17.101J.04 Height Regulations for all Lots with a Footprint Slope of >20%, Terraced, or Split**

Regulation	Downslope Lot Height Regulations With a Footprint Slope of:			Upslope Lot Height Regulations With a Footprint Slope of:	Additional Regulations
	> 20% and < 40%, and all terraced and split regardless of slope	> 40% and < 60%	> 60%	> 20%, terraced and split	

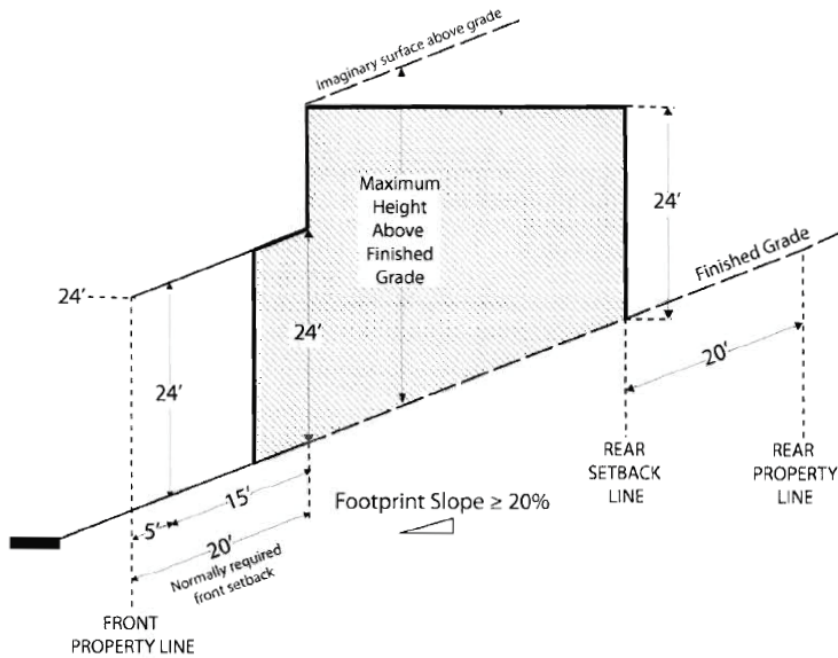
Maximum Height for Detached Accessory Structures	15 ft.	15 ft.	15 ft.	15 ft.	1
Maximum Wall Height Primary Building	32 ft.	34 ft.	36 ft.	32 ft.	1, 2
Maximum Wall Height Primary Building with a CUP	36 ft.	38 ft.	40 ft.	35 ft.	1
Maximum Pitched Roof Height Primary Building	36 ft.	38 ft.	40 ft.	35 ft.	1, 2
Maximum Height Above Edge of Pavement	18 ft.	18 ft.	18 ft.	N/A	1
Maximum Height Above the Ground Elevation at the Rear Setback Line	N/A	N/A	N/A	24 ft.	1
Maximum Height from Finished or Existing Grade (whichever is lower) Within 20' of the Front Property Line	N/A	N/A	N/A	24 ft.	1, 3

**Additional Regulations for Table 17.101J.04:**

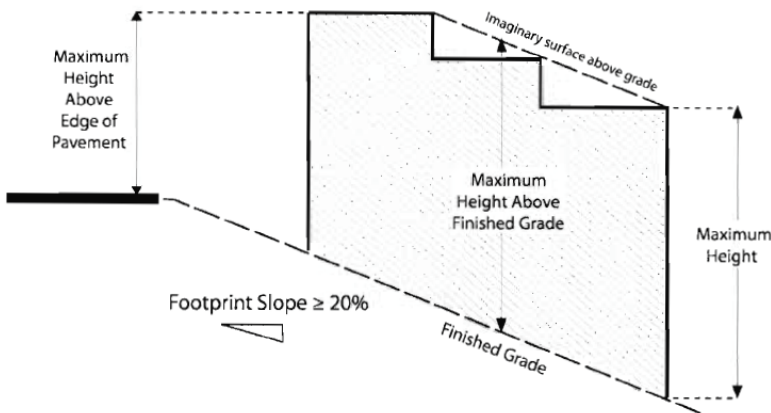
1. See Section 17.108.030 for allowed projections above height limits and Section 17.108.020 for increased height limits for civic buildings.
2. On a downslope lot greater than seventeen percent (20%) footprint slope, or that is terraced or split, the rear wall of an attached garage or carport may exceed the wall height and roof height by five (5) feet, but may not exceed eighteen (18) feet above ground elevation at edge of pavement, if the garage or carport conforms with all of the following criteria:
  - a. Maximum width is twenty-two (22) feet and maximum depth is twenty (20) feet; and
  - b. Garage or carport floor is at the same level as the edge of the street pavement resulting from the project at the center point of the driveway entrance or is at a lower level; and
  - c. Maximum height above the garage or carport floor is ten (10) feet for walls to the top of the plate or flat roof, and twelve (12) feet for pitched roofs (see Illustration for Table 17.17.06 [Additional Regulation 2], below).
3. The building height is measured from finished or existing grade, whichever is lower.

Illustrations for Table 17.101J.04  
\*for illustration purposes only

Upslope



Downslope



**C. Additional Development Regulations in the D-OK-1 and D-OK-2 Zones.**

Table 17.101J.05 below prescribes the standards for garage doors, retaining walls, stoops, and porches in the D-OK-1 and D-OK-2 Zones. The numbers in the "Additional Regulations" column refer to the regulations listed at the end of the Table.

**Table 17.101J.05 Additional Development Regulations in the D-OK-1 and D-OK-2 Zones**

Facility	Zones	Additional Regulations
----------	-------	------------------------



	D-OK-1	D-OK-2	
<b>Garages</b>			
Maximum Garage Door Width	16 ft.	16 ft.	
Maximum Garage Door Height	8 ft.	8 ft.	
Minimum Garage Door Recess	6 in.	6 in.	
<b>Retaining Walls</b>			
Maximum Front Retaining Wall Height	30 in.	30 in.	1
Maximum Side and Rear Retaining Wall Height	--	--	
<b>Stoops</b>			
Minimum Landing Depth	5 ft.	5 ft.	
Minimum Landing Width	6 ft.	6 ft.	
<b>Porches</b>			
Minimum covered area	30 sq. ft.	30 sq. ft.	
Minimum elevation above grade	8 in.	8 in.	

**Additional Regulations for Table 17.101J.05:**

1. Retaining walls, if used in the front, must be set back a minimum of two (2) feet from the sidewalk.

**17.101J.060 - Subdivision**

The OKPUD is approved for 935 residential dwelling units and 82,000 sf. of non-residential space. No additional residential subdivisions are permitted.

**17.101J.070 – Conditional use permit criteria.**

A. The procedures in Chapter 17.134 apply in the D-OK Zones except for the criterion required by Section 17.134.050.D.

B. In the D-OK Zones, the following criterion replaces the criterion found in Section 17.134.050.D: That the proposal conforms to all applicable design review criteria set forth in the design review procedure at Section 17.101J.020.C and the Oak Knoll Design Guidelines.

#### **17.101J.080 - Other zoning provisions.**

- A. Home Occupations. Home occupations shall be subject to the applicable provisions of the home occupation regulations in Chapter 17.112.
- B. Nonconforming Uses. Nonconforming uses and changes therein shall be subject to the nonconforming use regulations in Chapter 17.114.
- C. General Provisions. The general exceptions and other regulations set forth in Chapters 17.102, 17.104, 17.106, and 17.108 shall apply in the D-OK Zones to the extent not contrary to the standards specifically set forth in this Chapter and the Oak Knoll Design Guidelines.
- D. Recycling Space Allocation Requirements. The regulations set forth in Chapter 17.118 shall apply in the D-OK Zones.
- E. Landscaping and Screening Standards. The regulations set forth in Chapter 17.124 shall apply in the D-OK Zones to the extent not contrary to the standards specifically set forth in the Oak Knoll Design Guidelines.
- F. Buffering. All uses shall be subject to the applicable requirements of the buffering regulations in Chapter 17.110 with respect to screening or location of parking, loading, storage areas, control of artificial illumination, and other matters specified therein to the extent not contrary to the standards specifically set forth in the Oak Knoll Design Guidelines.
- G. Bicycle Parking. The bicycle parking requirements in Chapter 17.117 apply in the D-OK Zones.
- H. Special Regulations and Findings for Certain Use Classifications. The regulations set forth in Chapter 17.103 shall apply in the D-OK Zones to the extent noted in Table 17.101J.01.
- I. Performance Standards. The regulations set forth in Chapter 17.120 shall apply in the D-OK Zones.
- J. Hillside Subdivisions. The regulations set forth in Chapter 16.28 shall not apply in the D-OK Zones.

#### **17.101J.090 – Definitions.**

As used in Chapter 17.101J, the following words have the meanings defined below:

- A. Developable Area. The developable area is the lot area excluding required setbacks.
- B. Footprint Slope. Footprint slope means the grade across a lot from the front to back (or back to front) of the developable area.
- C. Principal Drive. Principal Drive is a private driveway in a commercial area that connects to secondary drives.

- D. Secondary Drive. Secondary Drive is a drive aisle located in a surface or structured parking lot.
- E. Split Lot. A split lot is a lot that was sloped and has been graded to have two different levels.
- F. Terraced Lot. A terraced lot is a lot that was sloped and has been graded to have more than two levels.

**Appendix C**  
Updated Rifle Range Creek  
Restoration Area and  
Habitat and Monitoring Plan  
(February 2017)

---

# Rifle Range Creek Restoration Area Habitat Mitigation and Monitoring Plan

OAK KNOLL MIXED-USE COMMUNITY DEVELOPMENT PROJECT  
OAKLAND, ALAMEDA COUNTY, CALIFORNIA

---

**Prepared For:**

Oak Knoll Venture Acquisition, LLC  
2392 Morse Avenue  
Irvine, CA 92614

Contact: Sam Veltri  
SVeltri@SunCal.com

**Prepared By:**

WRA, Inc.  
2169-G East Francisco Boulevard  
San Rafael, California 94901

Contact: Amanda McCarthy  
mccarthy@wra-ca.com

**Date:**

February 2017



## TABLE OF CONTENTS

1.0 INTRODUCTION.....	3
2.0 RESTORATION PROJECT .....	4
2.1 Location of Project.....	4
2.2 Project.....	4
3.0 EXISTING CONDITIONS WITHIN THE PROJECT AREA.....	5
3.1 Hydrology .....	5
3.2 Soils .....	5
3.3 Vegetation .....	5
3.4 Special-Status Species.....	6
4.0 RESTORATION AREA .....	7
4.1 Location .....	8
4.2 Ownership Status .....	8
4.3 Existing Conditions within the Restoration Area .....	8
4.3.1 Hydrology .....	8
4.3.2 Soils.....	8
4.3.3 Vegetation .....	9
4.4 Proposed Impacts within the Restoration Area .....	9
4.4.1 Creek Impacts .....	9
4.4.2 Tree Impacts.....	10
4.4.3 Functions and Values of the Jurisdictional Areas to be Restored.....	11
4.5 Beneficial Uses of the Restoration Area.....	12
4.6 Present and Historical Uses of Restoration Area.....	14
4.7 Present and Proposed Uses of Adjacent Areas.....	14
4.8 Functional Assessment (CRAM) Scores.....	14
5.0 PROPOSED CONDITIONS OF RESTORATION AREA .....	16
5.1 Restored Riparian Corridor Description .....	16
5.1.1 Structural Restoration Activities and Grading Plan .....	16
5.2 Anticipated Functions and Values of the Restoration Area.....	17
5.3 Impact Avoidance Measures .....	19
5.4 Planting Plan .....	19
5.5 Non-Native Vegetation Removal.....	21
5.6 Irrigation.....	21
5.7 Implementation Schedule.....	21
5.8 Construction Drawings .....	21
5.9 As-Built Conditions .....	22
6.0 RESTORATION AREA MONITORING AND SUCCESS CRITERIA.....	23
6.1 Summary of Restoration Success Criteria .....	23
6.2 Monitoring Activities.....	24
6.2.1 Hydrological and Erosion Monitoring for Stream Restoration .....	24
6.2.2 Monitoring of Riparian Tree Plantings.....	24
6.2.3 Quantitative CRAM Evaluations.....	25
6.2.4 Qualitative Monitoring for Non-native, Invasive Species.....	25
6.3 Monitoring Schedule and Reporting Requirements .....	26
6.4 Notification of Completion .....	26
7.0 CONTINGENCY MEASURES .....	28
8.0 LONG-TERM MANAGEMENT OF THE RESTORATION AREA .....	29
8.1 Long-term Maintenance Plan .....	29
8.1.1 Debris Removal.....	29
8.1.2 Sign Inspection.....	29
8.1.3 Erosion Control.....	29
8.1.4 Non-Native Plants .....	29
8.2 Property Ownership and Management.....	30
8.3 Long-Term Funding Requirements .....	30
9.0 REFERENCES.....	31

## LIST OF TABLES

Table 1. Summary of proposed net changes aquatic and riparian habitats.....	10
Table 2. Summary of riparian trees within the creek corridor grading limits. ....	11
Table 3. Existing Functions and Values within the Restoration Area .....	12
Table 4. Beneficial Uses of Waters of the State that May be Affected by the Project .....	13
Table 5. Summary of existing and projected functional assessment (CRAM) scores for Rifle Range Creek.....	15
Table 6. Existing Proposed Habitats .....	16
Table 7. Anticipated Functions and Values for the Restoration Area .....	18
Table 8. Proposed Plantings and Other Treatments within Each Planting Zone .....	20
Table 9. Proposed Plant Palette for Riparian and Buffer Planting Areas .....	20
Table 10. Restoration Areas Success Criteria Summary .....	23
Table 11. Riparian Plantings Survival Criteria .....	25
Table 12. Monitoring and Reporting Schedule .....	27
Table 13. Restoration Area Long-Term Maintenance Schedule .....	29

## APPENDICES

- Appendix A. Project Figures
- Appendix B. Existing Rifle Range Creek Channel Corridor Geomorphic Reconnaissance
- Appendix C. Long-Term Management Analysis

## 1.0 INTRODUCTION

On behalf of Oak Knoll Venture Acquisition, LLC, WRA, Inc. (WRA) prepared this Riparian Restoration and Monitoring Plan (Restoration Plan) for the Rifle Range Creek corridor (Restoration Area) in conjunction with the redevelopment of the former Oak Knoll Naval Medical Center (Project Area) in Oakland, California. The primary objectives of the Restoration Plan are to: (1) describe the restoration activities designed to restore riparian habitat along Rifle Range Creek and portions of its tributaries, Powerhouse Creek and Hospital Creek; (2) describe restoration engineering and planting schemes; and (3) describe the performance standards and monitoring plan for the Restoration Area. The Restoration Plan calls for restoring 3,820 linear feet of Rifle Range Creek and its associated riparian habitat, significantly increasing its biological habitat value. In addition, limited restoration activities will occur along 201 linear feet of Powerhouse Creek and 299 linear feet of Hospital Creek, for a total of 4,472 linear feet of creek and riparian restoration. The Project will also create an additional 13 linear feet of creek by realigning the existing channel, yielding a post-restoration total of 4,514 linear feet of restored creek and riparian habitats. Figures showing the proposed restoration discussed in this Plan are included in Appendix A.

### *Responsible Parties*

The applicant is:

Oak Knoll Venture Acquisition, LLC  
2392 Morse Avenue  
Irvine, CA 92614  
Contact: Sam Veltri  
Phone: (949) 241-8436

The preparer of this plan is:

WRA, Inc.  
2169-G East Francisco Boulevard  
San Rafael, California 94901  
Contact: Amanda McCarthy  
Phone: (415) 524-7456



## 2.0 RESTORATION PROJECT

### 2.1 Location of Project

Oak Knoll is a Master Planned Residential Community Development Project (“Project”) consisting of the approximately 167-acre former Naval Medical Center Oakland (NMCO) property at Oak Knoll, two parcels owned by the public agency and an adjacent 15-acre parcel (known as the “Hardenstine parcel”). The Project Area is located approximately seven miles southeast of downtown Oakland and is bounded by Mountain Boulevard and Interstate 580 to the west, Keller Avenue to the north and east, and Sequoyah Road to the south (Figure 1). In general, topography in the Project Area is downsloping toward the south west, from a prominent ridge at the eastern side of the property. Rifle Range Creek, a tributary of Arroyo Viejo, flows from north to south across the Project Area and is one of the site’s most prominent natural features. Surrounding land uses are primarily residential development, small local commercial centers, and regional open space.

### 2.2 Project

The NMCO facility was decommissioned in 1996 and has been unoccupied since that time, with the exception of continued operations at two privately owned inholdings: the Sea West Federal Coast Guard Credit Union and the Seneca Center for Children and Families. All structures within the NMCO, except the Club Knoll structure, were demolished between 2010 and 2011. The currently proposed Project would develop up to 935 residential units comprised of a range of single-family housing types, townhomes, and multifamily units that would be developed throughout the Project Area (Figure 2). A Village Center would provide a variety of neighborhood-serving retail of approximately 72,000 square feet of locally serving commercial uses and the highest density housing. The Project would also create approximately 75 to 85 acres of open space comprising an extensive network of parks, trails, and walkways that would weave through the Project Area, connecting various neighborhoods within the Project Area with adjacent open space areas and neighborhoods.

A key component of the Oak Knoll project is the enhancement and restoration of Rifle Range Creek and its tributaries. Rifle Range Creek has experienced severe incision which has lowered the channel elevation relative to the surrounding landscape and has resulted in an unstable and eroding channel and banks. Rifle Range Creek includes a mix of open and culverted sections of drainage (Figure 3). Open sections show evidence of active erosion in the creek channel and along the banks, leading to unstable conditions in most areas. Creek restoration activities include removing or replacing the existing degraded storm drain network, removing existing roadway crossings and in-channel culverts, and daylighting culverted sections (1,041 linear feet). The Oak Knoll project presents an opportunity to address some of the large-scale impacts to the creek that have occurred as a result of development and hydrological modification in the watershed, and invasion by non-native plant species. Through a combination of re-alignment, grading, and planting, the flow capacity, stability, and habitat quality of Rifle Range Creek and its tributaries will be improved.

### 3.0 EXISTING CONDITIONS WITHIN THE PROJECT AREA

The Project Area consists of the approximately 167-acre abandoned NMCO facility as well as the adjacent 15-acre Hardenstine parcel. The NMCO facility was decommissioned in 1996 and has been unoccupied since that time. All structures within the NMCO, except the Club Knoll structure, were demolished between 2010 and 2011. The Project Area still contains remnants of infrastructure installed by the United States Navy while the facility was operational including roads, parking lots, building foundations, in-stream utilities, channel protection structures, and a storm drain network. Many of the structures in the Project Area are in deteriorated condition and/or have been vandalized. Rifle Ranch Creek flows across the Project Area, entering and exiting the property via culverts that run under adjacent urban development (Figure 3). The Project Area is dominated by developed and landscaped areas; however, fragments of disturbed native habitat are scattered throughout the former NMCO site. Additionally, the Hardenstine parcel consists of mostly native habitats.

#### 3.1 Hydrology

Rifle Range Creek flows from north to south through the central portion of the Project Area and is a notable natural feature on the site (Figure 3). The creek is the largest and northernmost of three tributaries to Arroyo Viejo that originate in the Oakland hills. Rifle Range Creek and its tributaries, and a small wetland (0.04 acre) in the northeast corner of the site are the only Section 404 jurisdictional Waters of the United States located in the Project Area (Figure 4). The principal hydrologic sources for the Project Area are direct precipitation and surface runoff.

#### 3.2 Soils

The Alameda County Soil Survey (USDA 1981) indicates that the Project Area has six native soil types (Figure 5):

- A. Botella loam, 0 to 2 percent slopes
- B. Climara clay, 30 to 50 percent slopes
- C. Los-Osos-Millsholm complex, 50 to 75 percent slopes
- D. Millsholm silt loam, 50 to 75 percent slopes
- E. Xerorthents-Millsholm complex, 30 to 50 percent slopes
- F. Xerorthents-Millsholm complex, 50 to 75 percent slopes.

Of these soil types, only (A) and (E) are found within the Restoration Area. These soil types are described in detail in section 4.3.2.

#### 3.3 Vegetation

The Project Area is dominated by urban development, including the remnants of building foundations, parking lots, and roads. The associated infrastructure for this former development resulted in widespread ground disturbance. Introduced landscape plants are found throughout the Project Area, and include trees such as blue gum eucalyptus (*Eucalyptus globulus*), Bailey's acacia (*Acacia baileyana*), and Monterey pine (*Pinus radiata*). Non-native plant communities in the Project Area include areas dominated by French broom (*Genista monspessulana*), blue gum eucalyptus, Monterey pine, and non-native annual grasses. In addition, five native plant communities were identified within the Project Area including coast live oak riparian forest, coast live oak woodland, Valley needlegrass grassland, coyote brush scrub, and chamise chaparral. Coast live oak riparian forest, coast live oak woodland, and non-native plant communities are found within the Restoration Area and are described in detail in 4.3.3.

### 3.4 Special-Status Species

Several special-status plant and animal species have been documented to occur, or potentially occur, in the vicinity of the Project Area. However, a search of the California Department of Fish and Wildlife Natural Diversity Database (CNDDDB 2015) found no documented occurrences of special-status species within the Project Area. Surveys for Alameda whipsnake (*Masticophis lateralis euryxanthus*) in 2006 yielded negative results. According to the Biological Resource Assessment Report (WRA 2006a), three special-status wildlife species have a high to moderate potential of occurring in the Oak Knoll Project Area: Cooper's Hawk (*Accipiter cooperi*), Allen's Hummingbird (*Selasphorus sasin*), and Yuma myotis (*Myotis yumanensis*). One special-status plant species, Oakland star tulip (*Calochortus umbellatus*), is known to occur within the Project Area (outside of the Restoration Area). No other special-status plants are expected to occur in the Project Area due to the site's disturbance history, lack of suitable habitat, and negative results during 2006 rare plant surveys (WRA 2006b).

## 4.0 RESTORATION AREA

To develop this Habitat and Mitigation Monitoring Plan, WRA first analyzed existing conditions within the Project Area, focusing on the Restoration Area. WRA then considered the opportunities and constraints at the site, regional habitat goals, and economically/logistically feasible alternatives. The Restoration Plan focuses on the following objectives: (1) retaining the existing creek alignment and preserving high-quality trees where possible, (2) removing existing culverts and gabions, (3) reducing channel gradients, (4) creating a compound channel, and (5) stabilizing the creek banks. Public educational displays and passive recreational opportunities adjacent to the creek may also be included in the overall design to enhance the creek's education and recreational value.

Rifle Range Creek flows across the Project Area, entering and exiting the property via culverts that run under urban development (Figure 3 and 4). Rifle Range Creek has two tributaries, Powerhouse Creek and Hospital Creek. Rifle Range Creek flows west from the Oakland hills and is part of the Arroyo Viejo watershed. Upstream of the Project Area, an in-stream Alameda County flood control detention basin regulates stormwater flows and has altered sediment transport into the downstream reaches of the creek.

The aboveground portions of Rifle Range Creek within the Project Area total approximately 2,779 linear feet, and have been divided into several reaches as shown on the delineation map (Figure 3). The reaches are numbered 1 through 6 starting downstream and moving upstream. Reach 5 and portions of other reach have been culverted and are indicated with a solid line on Figure 3. Each reach consists of a mix of riffles, runs, and pools. Patches of wetland vegetation are present within some reaches, but the creek channel is primarily unvegetated perennial stream habitat.

The existing creek banks range from vertical to three to one slopes, and are highest, steepest, and most unstable where the channel is deeply incised relative to the adjacent land. Channel incision is most dramatic in the central portions of the creek (Reach 3 and Reach 4). In these areas, the channel has eroded as much as 25 feet below the top-of-bank. In other areas (e.g. small sections of Reach 3), although the channel is incised, the bank slopes are more stable and are supported by riparian vegetation. Immediately upstream of structures that stabilize the channel grade, such as road crossings or rip-rap, channel incision is limited and small inset floodplain areas have developed, which have supported a slight channel meander. In Reach 6, the bed and banks have been stabilized with gabions and are less incised relative to the surrounding area, although the gabions are undercut and failing. Much of the creek bed in this reach has been lined with crushed rock approximately 6 to 12 inches in diameter, held in place by chain-link fence material staked flat against the rocks. This technique was used to minimize erosion and shifting of the channel, but has reduced functions and values of the reach and will ultimately fail. Trees and other vegetation form a canopy over most of the creek and its tributaries. A more detailed reach-by-reach description is provided in Appendix B.

The unculverted portion of Hospital Creek extends approximately 299 linear feet upstream from its confluence with Rifle Range Creek. The banks of Hospital Creek are heavily overgrown with non-native species. However, the upland hillslope to the south of the channel is stable, steep, and well vegetated with mature oaks.

The unculverted portion of Powerhouse Creek extends approximately 201 linear feet upstream from its confluence with Rifle Range Creek, and is deeply incised into the surrounding landscape. Several concrete block structures create channel steps in the creek to increase bank stability.

A wetland delineation of the Project Area was conducted by WRA on May 30 and 31, and June 21 and 28, 2006 and a jurisdictional determination was issued by the Corps on December 4, 2007 (Corps File No. 4002405) (WRA 2007). A total of 2,779 linear feet of free-flowing Waters of the United States and 1,041 linear feet of culverted Waters of the United States from Rifle Range Creek, 201 linear feet of Waters of the United States from Powerhouse Creek, and 299 linear feet of Waters of the United States from Hospital Creek were identified within the Project Area (Figure 4). The delineation was later re-verified by the Corps on May 16, 2013.

#### **4.1 Location**

As shown in Figure 3, the Restoration Area has a north-south alignment through the center of the Project Area. The Restoration Area includes Rifle Range Creek and short portions of two tributaries, associated riparian habitat, and adjacent upland areas that will be restored along with the riparian habitat to serve to broaden the restored riparian corridor.

#### **4.2 Ownership Status**

The owner of the site, including the Restoration Area, is Oak Knoll Venture Acquisition, LLC.

#### **4.3 Existing Conditions within the Restoration Area**

##### *4.3.1 Hydrology*

The principal hydrologic sources within the Restoration Area are direct precipitation, surface runoff, and storm drain flows.

##### *4.3.2 Soils*

The soils within the Restoration Area include two of the five soil types found within the Project Area: Xerothents-Millsholm complex, 30 to 50 percent slopes, and Botella Loam, 0 to 2 percent slopes.

**Botella loam, 0 to 2 percent slopes.** The Botella series consists of very deep, well-drained soils that formed in alluvium that derived mainly from sedimentary rock sources. Botella soils are on low terraces and alluvial fans and have slopes ranging from 0 to 2 percent. Surface runoff is slow, and the hazard of erosion is slight. In most areas this soil is used for urban development. In some areas it is used for vegetable crops. Inclusions of this soil are listed as hydric when they occur in floodplains (USDA-NRCS 1992).

**Xerothents-Millsholm complex, 30 to 50 percent slopes.** The soils in this complex are roughly 70 percent loamy Xerothents and 20 percent Millsholm loam. Included in mapping, and making up 10 percent of the complex, are small areas of Maymen loam and Los Gatos loam. The Xerothents in this complex are well drained to somewhat excessively drained. They consist of soil material that has been altered by cutting or filling for urban development; as a result, they have variable soil characteristics. Runoff is rapid, and the hazard of erosion is high. The Millsholm soil is shallow and well drained. It formed in residuum of shale and fine-grained sandstone. This soil makes up most of the undisturbed areas in this complex. Runoff is rapid, and the hazard of erosion is high. Areas of this complex are used primarily as sites for residential developments. This soil type is not listed as a hydric soil (USDA-NRCS 1992).

### 4.3.3 Vegetation

Restoration activities will impact portions of existing riparian vegetation, non-native grassland, and landscaped areas dominated by blue gum eucalyptus and Monterey pine trees. Riparian areas occur along the entire length of Rifle Range Creek and its tributaries with the exception of some of the culverted reaches of Rifle Range Creek. Approximately 4.19 acres of riparian habitat along Rifle Range Creek and its tributaries will be removed and replanted. An additional 2.66 acres of riparian habitat will be preserved and enhanced (Figures 6a–6e). Existing vegetation within the Restoration Area includes coast live oak riparian forest, coast live oak woodland, and non-native plant communities.

**Coast live oak riparian forest** on the site is dominated by coast live oak (*Quercus agrifolia*), willow (*Salix* spp.), horsetail (*Equisetum* sp.), California blackberry (*Rubus ursinus*), poison oak (*Toxicodendron diversilobum*), and sedge (*Carex* sp.). Non-native species present in coast live oak riparian forest include: Himalayan blackberry (*Rubus armeniacus*), periwinkle (*Vinca major*), and western hemlock (*Tsuga heterophylla*). This habitat type is restricted to a narrow, fragmented strip along Rifle Range Creek.

**Coast live oak woodland** is dominated by coast live oak with an understory of non-native annual grasses. This community is located primarily adjacent to Reach 3 within the Restoration Area. Monterey pine and eucalyptus are present in some areas, as well as native species such as Pacific madrone (*Arbutus menziesii*) and California poppy (*Eschscholzia californica*).

**Non-native communities** in the Restoration Area are categorized together in Figure 3, and are characterized by scattered pockets of disturbed habitat dominated by varying mixes of non-native trees, shrubs, grasses, and forbs. Dominant species include eucalyptus, Monterey pine, scotch broom (*Cytisus scoparius*), slender wild oat (*Avena barbata*), rip-gut brome (*Bromus diandrus*), perennial mustard (*Hirschfeldia incana*), yellow star thistle (*Centaurea solstitialis*), and purple star thistle (*Centaurea calcitrapa*).

## 4.4 Proposed Impacts within the Restoration Area

### 4.4.1 Creek Impacts

Many portions of Rifle Range Creek currently exhibit signs of active erosion, are devoid of vegetation, and/or have undercut gabions. Restoration and enhancement efforts along Rifle Range Creek and its tributaries would temporarily impact 3,279 linear feet of unculverted waters of the United States due to temporary dewatering and stream diversion during construction. In addition, 1,041 linear feet of culverted waters along Rifle Range Creek will be temporarily impacted, of which 1,010 linear feet will be daylighted (Table 1).

Approximately 450 linear feet of existing channel would be realigned laterally and restored, and a 40-foot wide clear span bridge would be added over one of the realigned sections. Fill material would consist of clean cobbles, gravels, and soil excavated from the channel banks as well as logs and boulders for grade control.

Additional restoration-related activities, including bank stabilization, invasive species removal, and replanting of the riparian habitat using native trees, shrubs, and grasses will occur along Rifle Range Creek and its tributaries. Additional fill would be required between the ordinary high water mark and the top-of-bank to create the floodplain terraces and stabilize creek banks.

Table 1. Summary of proposed net changes aquatic and riparian habitats.

<b>Habitat</b>	<b>Pre-Restoration (Existing)</b>	<b>Post Restoration (Proposed)</b>	<b>Net Change</b>
Waters of the State (unculverted)	3,301 linear feet; 0.64 acre	4,494 linear feet; 1.48 acres	+1193 linear feet; +0.84 acre
Waters of the State (culverted)	1,041 linear feet; 0.12 acre	42 linear feet; 0.01 acre	-999 linear feet; -0.12 acre
<i>Total Waters</i>	<i>4,342 linear feet; 0.76 acre</i>	<i>4,536 linear feet; 1.49 acres</i>	<i>+194 linear feet; +0.72 acre</i>
Riparian Habitat (including adjacent oak woodland)	8.14 acres	16.97 acres	+8.83 acres

#### 4.4.2 Tree Impacts

Tree removal would be required to facilitate restoration activities including bank stabilization. Comprehensive tree surveys of the Project Area and Restoration Area were conducted in 2006 and 2015.. The following data was collected for each tree:

- Each tree was identified to species
- Each tree was permanently tagged with a unique identification number and its location was mapped with GPS
- The diameter of each tree was measured at a point 54” above grade.
- The health and structural condition was rated using a 0-5 scale.
- The suitability for preservation was evaluated based on a combination of variables including health, age, and structural condition of the tree.

The highest quality trees were identified early in the restoration planning process and were avoided to the maximum extent practicable while still achieving the goals of the Project. Table 2 provides a preliminary list of all protected trees under the City of Oakland Tree Ordinance that would be removed in the Restoration Area, based on the 2006 and 2015 tree surveys. The City of Oakland Tree Ordinance defines protected trees to include all oak trees 4” or greater in diameter at breast height (DBH) and other species (excluding Monterey pine and blue gum) that are 9” or greater in DBH. All tree impacts will be mitigated for in accordance with the City of Oakland Tree Ordinance and other applicable regulations. Based on preliminary analysis, we anticipate the number of trees impacted will be up to 15% greater than was estimated using 2006 data due to tree growth and recruitment.

Table 2. Summary of riparian trees within the creek corridor grading limits.

Species	DBH Size Class				Grand Total
	4.0-8.9	9.0-17.9	18.0-35.9	>36.0	
<i>Native</i>	31	87	93	35	246
<i>Aesculus californica</i>	-	2	2	-	4
<i>Alnus rhombifolia</i>	-	11	4	2	17
<i>Quercus agrifolia</i>	31	54	64	17	166
<i>Salix laevigata</i>	-	7	9	7	23
<i>Salix lasiolepis</i>	-	9	11	7	27
<i>Sambucus nigra</i> ssp. <i>caerulea</i>	-	3	2	1	6
<i>Sequoia sempervirens</i>	-	-	1	1	2
<i>Umbellularia californica</i>	-	1	-	-	1
<i>Non-native</i>	-	25	19	7	51
<i>Acacia baileyana</i>	-	-	1	-	1
<i>Acacia melanoxylon</i>	-	8	8	3	19
<i>Juglans hindsii</i>	-	1	-	-	1
<i>Ligustrum japonicum</i>	-	1	-	-	1
<i>Ligustrum lucidum</i>	-	1	-	-	1
<i>Pinus ponderosa</i>	-	1	-	-	1
<i>Pittosporum undulatum</i>	-	-	2	1	3
<i>Platanus x acerifolia</i>	-	-	3	1	4
<i>Populus nigra</i> 'Italica'	-	6	4	2	12
<i>Prunus cerasifera</i>	-	1	-	-	1
<i>Prunus dulcis</i>	-	1	-	-	1
<i>Prunus</i> sp.	-	3	1	-	4
<i>Quercus ilex</i>	-	1	-	-	1
Unknown	-	1	-	-	1
<b>Grand Total</b>	<b>31</b>	<b>112</b>	<b>112</b>	<b>42</b>	<b>297</b>

Note: *Tree impacts are based on 2006 and 2015 tree survey data*

#### 4.4.3 Functions and Values of the Jurisdictional Areas to be Restored

Typical functions and values attributed to Waters of the United States and associated riparian habitat include attenuating flood flows, sediment, nutrient, and toxicant retention/transformation, erosion control, habitat for wildlife, and recreation. The functions and values of the jurisdictional areas proposed to be impacted within the Restoration Area are generally rated low to moderate because of their poor quality, small size, and surrounding land uses (Table 3).



Table 3. Existing Functions and Values within the Restoration Area

Function or Value	Rating of Function or Value	Rationale
Store and/or convey flood water	Low	The current incised and degraded nature of Rifle Range Creek results in less efficient flow conduction and increased rates of erosion.
Buffer storm surges	Low	The current incised and degraded nature of Rifle Range Creek makes the drainage less efficient at directing and containing storm surge flows.
Sediment and toxicant retention and stabilization	Low	The current incised nature of many areas of the drainage result in inadequate retention and stabilization of sediments and toxins.
Production export	Low	Most banks immediately adjacent to the drainage contain little vegetation and are heavily disturbed.
Uniqueness heritage	Moderate	Although currently of poor quality, Rifle Range Creek is the largest of three tributaries draining the Oakland hills watershed to Arroyo Viejo.
Nutrient removal/transformation	Low	Nutrient input is low due to the degraded state of surrounding habitat; also minimal vegetation in the small in-stream wetland areas does not adequately trap nutrients.
Wildlife diversity/abundance	Moderate	Although small and highly disturbed, Rifle Range Creek provides wildlife habitat in an otherwise urban surrounding; substantial presence of non-native vegetation in riparian corridor.
Aquatic diversity/abundance	Low	The current disturbed state of the drainage provides little habitat for aquatic life.
Recreational opportunities	Low	The site is currently fenced and unavailable for use by the public.

#### 4.5 Beneficial Uses of the Restoration Area

Beneficial uses and water quality objectives are required to be established for all Waters of the State, including both surface and ground waters. Beneficial uses of the surface and ground waters of the San Francisco Bay Region are discussed in the Water Quality Control Plan for the San Francisco Bay Basin (Region 2) (RWQCB 2015). Beneficial uses for surface waters are designated under section 303 of the Clean Water Act (40 CFR 131) and under the Porter-Cologne Act (California Water Code section 13050[f]). The State is required to specify appropriate water uses to be achieved and protected.

Waters located within the Project Area are part of the Lower Bay hydrologic sub area and include Rifle Range Creek and two tributaries: Hospital Creek and Powerhouse Creek. The Water Quality Control Plan identifies beneficial uses for Rifle Range Creek, but does not identify beneficial uses for the Hospital Creek and Powerhouse Creek tributaries. It is presumed that the beneficial uses for Hospital Creek and Powerhouse Creek are the same as for Rifle Range Creek. Beneficial uses designated for Rifle Range Creek include (Table 4): Warm Freshwater Habitat (WARM), Wildlife Habitat (WILD), Water Contact Recreation (REC-1), and Non-Water Contact Recreation (REC-2). Additionally, restoration activities, specifically the creation of step pools, are expected to net an additional beneficial resource (Freshwater Replenishment [FRESH]) as water quality is improved and positively contributes to the salinity balance of the San Francisco Bay with higher quality freshwater input. The definitions for each designated and proposed beneficial use application to Rifle Range Creek and its tributaries are included in Table 4.

One goal of this HMMP is to compensate for Project-related impacts to Waters of the State and their beneficial uses. Beneficial uses of Waters of the State that are existing in the Project Area (already designated in the Water Quality Control Plan) will be temporarily impacted, but upon Project completion will be preserved, enhanced, and/or restored to compensate for the temporary impact. Additionally, Project restoration activities may result in new beneficial uses which have not already been designated in the Water Quality Control Plan. Existing and proposed beneficial uses are summarized in Table 4.

Table 4. Beneficial Uses of Waters of the State that May be Affected by the Project

<b>State Recognized Beneficial Uses</b>	<b>Description</b>	<b>Existing Beneficial Uses<sup>1</sup></b>	<b>Proposed New Beneficial Uses<sup>2</sup></b>
Warm Freshwater Habitat (WARM)	Uses of water that support warm water ecosystems including, but not limited to, preservation or enhancement of aquatic habitats, vegetation, fish, or wildlife, including invertebrates.	X	
Wildlife Habitat (WILD)	Uses of waters that support wildlife habitats, including, but not limited to, the preservation and enhancement of vegetation and prey species used by wildlife, such as waterfowl.	X	
Water Contact Recreation (REC-1)	Uses of water for recreational activities involving body contact with water where ingestion of water is reasonably possible. These uses include, but are not limited to, swimming, wading, water-skiing, skin and scuba diving, surfing, whitewater activities, fishing, and uses of natural hot springs.	X	
Noncontact Water Recreation (REC-2)	Uses of water for recreational activities involving proximity to water, but not normally involving contact with water where water ingestion is reasonably possible. These uses include, but are not limited to, picnicking, sunbathing, hiking, beachcombing, camping, boating, tide pool and marine life study, hunting, sightseeing, or aesthetic enjoyment in conjunction with the above activities.	X	
Freshwater Replenishment (FRESH)	Uses of water for natural or artificial maintenance of surface water quantity or quality.		X

<sup>1</sup> Will be preserved, enhanced, and/or restored upon completion of restoration activities.

<sup>2</sup> Will be created as a result of the Project.

#### **4.6 Present and Historical Uses of Restoration Area**

During the Navy's tenure on the site, channel and bank erosion problems were treated by introducing rock and concrete rubble into the channel in various forms; some of these materials have provided a haphazard form of grade control. Despite these erosion control efforts, Rifle Range Creek and its tributaries have experienced channel incision as a result of increased runoff and more rapid concentration of peak flows from the urbanization of both on-site areas and off-site areas upstream of the Project Area.

#### **4.7 Present and Proposed Uses of Adjacent Areas**

Areas immediately surrounding the Restoration Area are characterized by decommissioned naval hospital and base facilities, including roads, parking lots, and landscaped areas. Areas adjacent to the riparian corridor will be developed into housing and commercial uses as part of the Oak Knoll Mixed Use Community Development Project. Once restored, Rifle Range Creek will provide a natural, continuous corridor through the larger Project Area.

#### **4.8 Functional Assessment (CRAM) Scores**

A functional assessment of the existing habitat conditions in Rifle Range Creek was completed in September 2015 using the California Rapid Assessment Mythology (CRAM). Assessment areas (AAs) were established in three reaches (Reach 1, Reach 3, and Reach 6) of Rifle Range Creek. The overall average score for these three reaches was 57 (Table 5). We then projected post-restoration scores by assessing conditions at a reference site (Glen Echo Creek in Oakland) that experienced similar bank reconstruction/stabilization, and by reviewing and analyzing the creek design plans (Figures 6a–6n). Glen Echo Creek is much more confined by existing development compared to Rifle Range Creek and thus would score lower than Rifle Range Creek on most attributes, but provides a good analog for projecting the biotic and physical structure attributes following complete reconstruction of the bed and banks. Based on conditions observed at the reference site and the creek design plans, the overall average projected post-restoration score for Rifle Range Creek is 68, an increase of 11 points relative to existing conditions (Table 5).

Table 5. Summary of existing and projected functional assessment (CRAM) scores for Rifle Range Creek.

CRAM Attribute	Existing Condition Score	Projected Score (+5 Years)	Projected Net Change	Rationale for Projected Change
<i>Buffer and Landscape Connectivity</i>	36.0 ± 4.3	50.7 ± 13.2	+14.7	
Stream Corridor Continuity	3.0 ± 0.0	5.0 ± 3.5	+2.0	Projected score increases due to daylighting of ~1000 linear feet of stream channel.
% of AA with Buffer	7.0 ± 1.7	11.0 ± 1.7	+4.0	Projected score increases due to overall widening of riparian corridor and minimum 5m buffer between designed top of bank and hardscape.
Average Buffer Width	3.0 ± 0.0	3.0 ± 0.0	No change	There is no change in projected score. The design incorporates a small increase in the average buffer width, but the increase is not enough to change the score.
Buffer Condition	7.0 ± 1.7	9.0 ± 0.0	+2.0	Score increases due to enhancement of buffer zone and restoration with native plant species.
<i>Hydrology</i>	61.1 ± 9.6	83.3 ± 0.0	+22.2	
Water Source	6.0 ± 0.0	6.0 ± 0.0	No change	There is no change in projected score because the water source will remain the same.
Channel Stability	6.0 ± 0.0	12.0 ± 0.0	+6.0	Projected score increases due to stabilization of currently degrading stream.
Hydrologic Connectivity	10.0 ± 3.5	12.0 ± 0.0	+2.0	Projected score increases due to widening of the floodplain.
<i>Physical Structure</i>	70.8 ± 7.2	75.0 ± 0.0	+4.2	
Structural Patch Richness	9.0 ± 0.0	9.0 ± 0.0	No change	There is no change in projected score; however, the types of patches will change. For example, the channel will no longer have undercut banks, but will have secondary channels and vegetated islands.
Topographic Complexity	8.0 ± 1.7	9.0 ± 0.0	+1.0	Projected score increases slightly due to the addition of a terraced floodplain and micro topographic features (e.g. woody debris, vegetated boulder clusters, etc.)
<i>Biotic Structure</i>	60.2 ± 5.8	61.1 ± 4.8	+0.9	
No. of Plant Layers	8.0 ± 1.7	9.0 ± 0.0	+1.0	Projected score increases slightly due to the addition of a tall (1.5 to 3.0 m) layer.
No. of Co-dominants	6.0 ± 0.0	9.0 ± 0.0	+3.0	Projected score increases due to incorporation of a diverse planting palette and planned removal/control of invasive weeds that have excluded other species.
Percent Invasion	6.0 ± 3.0	9.0 ± 0.0	+3.0	Projected score increases due to planned removal/control of invasive species.
Horizontal Interspersion	7.0 ± 1.7	7.0 ± 1.7	No Change	There is no change in score; however, invasive dominated zones will be replaced with native dominated
Vertical Biotic Structure	8.0 ± 1.7	6.0 ± 0.0	-2.0	There is a slight decrease in projected score due to the time it will take vegetation to become fully developed.
<b>Overall</b>	<b>57.0 ± 3.4</b>	<b>67.5 ± 2.9</b>	<b>+10.5</b>	

## 5.0 PROPOSED CONDITIONS OF RESTORATION AREA

Implementation of the restoration program described in this Plan will result in the daylighting of a majority of the culverted portions of Rifle Range Creek, repair and reconstruction of most of the creek channel, and enhancement and expansion of degraded riparian habitat in the Restoration Area. Unculverted waters on the site will increase from 3,279 linear feet to 4,472 linear feet. The total acreage of riparian habitat and associated native upland vegetation will increase from 8.04 acres to 16.87 acres.

### 5.1 Restored Riparian Corridor Description

Rifle Range Creek and its tributaries within the Restoration Area have been impacted by upstream watershed development, as well as the Oak Knoll Naval Hospital development and infrastructure. Typical of many East Bay creeks, there is evidence of active erosion in the creek channel and along the banks, leading to unstable conditions in some areas. Despite the impacts of urbanization, the creek has largely maintained its original alignment and supports a corridor of riparian vegetation along the open channel reaches. Restoration activities will lead to a substantial increase in linear feet of unculverted Waters of the United States, as well as a significant increase in the acreage of the riparian corridor (Table 6). By restoring and enhancing Rifle Range Creek and its tributaries, project proponents aim to enhance the riparian habitat value, stabilize the creek channel and banks, accommodate stormwater flows, provide aesthetic amenities, allow for limited public access, and remove non-native species.

Table 6. Existing Proposed Habitats

Habitat	Pre-Restoration (Existing)	Post Restoration (Proposed)
Waters of the United States (unculverted)	3,279 linear feet; 0.50 acre	4,472 Linear feet; 1.38 acres
Waters of the United States (culverted)	1,041 linear feet; 0.12 acre	42 linear feet; <0.01 acre
Total Waters	4,320 linear feet; 0.62 acre	4,514 linear feet; 1.39 acres
Riparian Habitat (including riparian edge)	8.04 acres	16.87 acres

#### 5.1.1 Structural Restoration Activities and Grading Plan

The Restoration Project Area comprises six reaches of Rifle Range Creek and two associated tributaries, Powerhouse Creek and Hospital Creek (Figures 3-5). In addition, three in-stream wetlands are present within Rifle Range Creek. The six reaches of Rifle Range Creek have been numbered from 1 to 6 starting at the downstream end. Currently, Rifle Range Creek is composed of both open channel sections and culverted sections. Active erosion is evident in the creek channel and along both banks. Channel incision has resulted in a deepened channel with over-steepened banks. The channel has an average grade of approximately three percent within the Project Area.

The overall restoration approach is to daylight all four of the culverts in the project reach; remove non-native vegetation and replant with native plants; remove existing obsolete infrastructure (e.g. stormdrain outfalls), trash and construction debris from the channel and banks; stabilize headcuts in two deeply incised reaches that threaten upstream areas; and use a combination of grading and biotechnical methods to stabilize actively eroding bank areas that are too steep to support riparian vegetation. A total of 1,041 feet of culverted channel would be daylighted and restored,

approximately 450 feet of existing channel would be realigned laterally and restored, and a 40-foot wide clear span bridge would be added over one of the realigned sections. Overall, the Project would result in a net increase of both jurisdictional other waters and riparian habitats (Figures 6a–6j).

Earthwork and grading activities are proposed to reduce bank slopes, reduce the channel gradient, and stabilize the creek banks. A total of 436 cubic yards of fill covering 0.22 acre would be placed within the Ordinary High Water Mark (OHWM) of the creek to re-align and stabilize the channel, and to reduce the channel gradient. Fill material would consist of clean cobbles and gravels as well as logs and boulders for grade control. Additional fill would be required above the OHWM to create the floodplain terraces and stabilize creek banks.

Grading would be required to reduce channel slopes and to establish suitable conditions for the installation of stabilization structures and plantings. Grading activities would include re-profiling the creek banks, and roughening the channel to stabilize major knick points and provide continuity of the channel gradient (Figures 6a–6j). The existing and proposed creek profile is shown in Figure 7 and the typical creek channel cross-section that would result from these activities is shown in Figure 8. The newly restored channel would typically consist of a 12-foot-wide low flow channel, a floodplain terrace up to 40-feet-wide, and channel banks at between 1.5:1 and 3:1 slopes. Appropriate native vegetation would be selected based on slope characteristics and proximity to the creek (Figure 9).

In order to reduce the channel gradient and the associated stresses placed on the channel bed, the restoration project would include the installation of a series of steps as grade controls in selected locations along the length of the channel, including log drops and boulder step pools. These steps would be primarily located in daylight reaches where the steepness of the culvert to be removed necessitates grade control to create a stable slope (Figures 6a–6j and Figures 10a–10d). Approximately 20 to 40 log drops and ungrouted boulder step pools would be installed in Reaches 4, 5, and 6. The gradient of Reach 3 is primarily bedrock controlled, but a roughened channel section is proposed in the southern portion to stabilize an existing headcut. This roughened channel would extend into the northern and central portions of Reach 2. Reach 1 would be stabilized with grade control structures and log drops.

Excavation work is proposed along Reach 5. This portion of the creek is currently piped underground through a 636-foot-long culvert. Reach 5 would be daylighted by reconstructing an open channel. Culverts and fill material associated with road crossings would also be removed from this reach. The creek would be reconstructed and a bridge with a 60-foot span over the channel would be installed at the downstream end of Reach 5 (Figures 6f and 11).

## **5.2 Anticipated Functions and Values of the Restoration Area**

The riparian and aquatic habitat created on the site would provide increased functions and values as outlined in Table 7.

Table 7. Anticipated Functions and Values for the Restoration Area

Function or Value	Rating of Function or Value	Rationale
Store and/or convey flood water	High	Stabilizing the channel banks, raising the channel bottom, and expanding the floodplain within Rifle Range Creek will result in improved storage and conveyance of floodwaters. The restored creek will safely accommodate storm flows.
Buffer storm surges	High	The increased width of the floodplain within restored Rifle Range Creek will provide additional area to accommodate storm surges.
Sediment and toxicant retention and stabilization	High	The increased vegetation cover and width of the drainage, and resultant decreased flow rate, will greatly enhance the retention and stabilization of sediments and toxins.
Production export	High	The planting plan for the restored riparian corridor will increase vegetation and biomass production in the riparian corridor.
Uniqueness heritage	High	Rifle Range Creek enters and exits the Restoration Area through culverts, which then flow under urban development. The restored creek and associated riparian and buffer habitats, will form a continuous corridor with high biological habitat value in an otherwise largely urban area.
Nutrient removal/transformation	High	Nutrient removal and transformation processes will be improved within the restored Rifle Range Creek and its tributaries as a result of increased vegetation along creek banks.
Wildlife diversity/abundance	High	Wildlife diversity and abundance will increase after the restoration due to increased quality and size of the drainage and riparian areas, and a continuous vegetated corridor.
Aquatic diversity/abundance	High	Aquatic diversity and abundance will increase after the restoration due to increased habitat quality, increased habitat diversity, and reduction in water flow rate as a result of increased riparian vegetation and widening the floodplain.
Recreational opportunities	High	The restored riparian areas will provide birdwatching and educational opportunities. A recreational path will be located within the riparian edge/buffer adjacent to the restored riparian habitat.

### 5.3 Impact Avoidance Measures

In order to minimize impacts, the following measures shall be implemented:

- Silt fences will be erected around the perimeter of the riparian corridor during excavation to prevent sediment runoff.
- Soil stockpiles will be covered and surrounded by berms or gravel bags.
- The construction limit of disturbance will be clearly identified in the field.
- All disturbed areas will be protected from erosion by top hydroseeding and mulching, soil binders, or erosion control matting after final grading.
- All soil erosion and sediment control measures will be kept in place until construction is complete and/or the disturbed area is stabilized.
- Prohibit excavation, grading, drainage, and leveling within the dripline of any preserved tree unless approved by the project consulting arborist.
- Prohibit disposal or depositing of oil, gasoline, chemicals, or other harmful materials within the root protection zone of preserved trees or in drainage channels, swales, or areas that may lead to the dripline.
- Exclusionary fencing will be installed as necessary in areas where proposed public access, including streets and trails, are immediately adjacent to riparian areas. Such fencing will be designed to limit public access to 'riparian edge' areas, and to allow for unimpeded passage of wildlife along and across the riparian corridor.

### 5.4 Planting Plan

The planting plan discussed below is based on the current 60 percent designs. Some aspects of the plan may be altered as designs are finalized. Additionally, agency input on the draft designs may require design changes. Upon the completion of agency review, the planting plan will be finalized and submitted to the regulatory agencies for final approval.

The restored habitat will have three planting zones depending on elevation from the creek, and the plant species used in each zone will vary by location along creek. The three zones are: riparian floodplain zone, riparian upper bank, and riparian edge/buffer zone (Table 8). Plant species used in habitat restoration will be native riparian species currently found in the Project Area (Table 9).

Specifically tailored planting plans will be applied to the unique grading and slope conditions associated with the four different bank treatment types, with each plan incorporating the three riparian and riparian edge/buffer planting zones (Figure 9). All plantings will occur in specified planting areas (Figures 6a-6j). The bank treatment types are referred to as (1) bank grading; (2) preserve existing bank; (3) biotechnical stabilization; and (3) tree protection. Schematic drawings are included in Figure 9 and each bank treatment type is described below. Planting lists in each bank treatment type description below focus on upper bank planting. The riparian edge will be planted with oaks and native shrubs that can tolerate drier conditions, and species composition of the riparian edge will vary slightly between the four bank treatment types to fit in with existing preserved native habitat and soil and slope conditions.



Table 8. Proposed Plantings and Other Treatments within Each Planting Zone

Riparian Habitat Zone	Elevation	Proposed Vegetation	Erosion Control
1. Riparian Floodplain	one to three feet above stream thalweg	Primary: willow and alder Secondary: blue elderberry and creek dogwood at densities typical of riparian environments.	Use of natural materials, such as rocks, boulders, and logs as appropriate in the final design to create in-stream habitat and to control erosion
2. Riparian Upper Bank	three to 10 feet above stream thalweg	coast live oak, California buckeye, California bay, willow at densities typical of riparian environments.  Understory: California blackberry, California rose, snowberry, and native grasses.	Use of bank erosion materials to control erosion until vegetative cover is established.
3. Riparian Edge/Buffer	greater than 10 feet above stream thalweg	Native grasses, shrubs, oak woodland species at densities typical of 'riparian edge' environments.	Use of slope erosion materials where necessary to control erosion until vegetation cover is established.

Table 9. Proposed Plant Palette for Riparian and Buffer Planting Areas

Botanical Name	Common Name
<i>Aesculus californica</i>	California buckeye
<i>Alnus rhombifolia</i>	white alder
<i>Baccharis pilularis</i>	coyote brush
<i>Cornus sericea</i>	creek dogwood
<i>Heteromeles arbutifolia</i>	toyon
<i>Quercus agrifolia</i>	coast live oak
<i>Rhamnus californica</i>	coffeeberry
<i>Rosa californica</i>	California rose
<i>Rubus ursinus</i>	California blackberry
<i>Salix laevigata</i>	red willow
<i>Salix lasiolepis</i>	arroyo willow
<i>Sambucus mexicana</i>	blue elderberry
<i>Symphoricarpos albus</i>	snowberry
<i>Umbellularia californica</i>	California bay laurel

### Bank Grading

The bank grading treatment will be located on banks with slopes three to one or flatter. Approximately 275 trees per acre and 400 shrubs per acre will be planted in restored areas with this treatment. The upper bank will be planted with a diversity of overstory trees and a dense understory of native shrubs. The primary plants in this bank treatment include California buckeye, white alder, toyon, willow species, and California bay.

### Preserve Existing Bank

The "preserve existing bank" treatment will be located on banks where no grading is proposed. Approximately 50 trees per acre and 400 shrubs per acre will be planted in restored areas with this treatment. Existing native trees and shrubs will be preserved, and existing non-native understory

will be removed and replaced with native shrubs. The primary plants in this bank treatment include California buckeye, California rose, snowberry, and coyote brush.

### Biotechnical Stabilization

The biotechnical stabilization treatment will be applied on banks with slopes of approximately two to one to three to one. Approximately 150 trees per acre, 400 shrubs per acre, and 350 pole cuttings will be planted in restored areas with this treatment. To supplement adjacent stabilization measures, native trees and shrubs will be planted on the upper bank. Willows, alders, and dogwood will be planted along the low flow channel and terrace for additional stabilization. Additional species included in this bank treatment are coyote brush, coast live oak, coffeeberry, and California rose.

### Tree Protection

The tree protection treatment will be applied on banks with slopes of two to one to three to one. Approximately 150 trees per acre and 400 shrubs per acre will be planted in restored areas with this treatment. Under this treatment, signature native trees are to be preserved, potentially with reinforced support from a retaining wall and with supplemental plantings of native shrubs and trees. Native plant species in this bank treatment include white alder, California rose, coast live oak, and elderberry.

## **5.5 Non-Native Vegetation Removal**

Ruderal vegetation, including pampas grass, fennel, broom, and other non-native grasses and weedy species are present throughout the riparian corridor and most abundant in disturbed areas. Removal of all of this non-native vegetation is desirable to establish and maintain a native plant community after restoration and to reduce competition with planted vegetation. During restoration work, all non-native vegetation will be removed from the riparian corridor and adjacent areas.

## **5.6 Irrigation**

Planted trees and shrubs will receive irrigation during the dry season for a minimum of two years, and longer as needed. The restored areas shall be inspected after the second year to determine if irrigation should continue for an additional year. Visual observations of tree health and testing with soil probes can help to determine if further irrigation will be necessary. Irrigation water will be applied in a manner that encourages deep rooting, such as less frequent, but high volume watering. This will ensure the establishment of these plants, lessen the need for continued irrigation, and reduce the need for replacement plantings.

## **5.7 Implementation Schedule**

Planting in a given reach of the riparian corridor will begin after grading activities within that reach of the creek corridor have been completed. To reduce temporal impacts associated with riparian vegetation removal, the completion of plant and irrigation installation will occur within six months of ground disturbance in any given reach of the Restoration Area.

## **5.8 Construction Drawings**

Construction drawings are included in Appendix A (Figures 6a-6j through Figure 12). Prior to construction, final versions of these documents will be submitted to the Corps, Regional Water Quality Control Board (RWQCB), and California Department of Fish and Wildlife (CDFW) in order for

agency staff to confirm that the final design is in compliance with the spirit and intention of the design drawings contained herein.

### **5.9 As-Built Conditions**

A letter report and plans outlining the as-built conditions of the restored riparian corridor will be prepared and submitted to the Corps, RWQCB, and CDFW within three months of completing the construction and planting of the Restoration Area.

## 6.0 RESTORATION AREA MONITORING AND SUCCESS CRITERIA

Monitoring will be performed to determine whether the Restoration Area has achieved proposed success criteria. The majority of the monitoring activities will be limited to a 5-year duration with only riparian tree planting monitoring and CRAM assessments extending to 10 years.

### 6.1 Summary of Restoration Success Criteria

Success criteria for trees and shrubs installed in the planting areas will be based on survival rates, plant growth, and plant vigor assessed by visual observation during the ten-year monitoring period. Plant growth and vigor will be assessed as either "good, fair, poor, or dead". Percent cover and species diversity estimates will be made in areas planted with grasses and forbs. Because of shading effects, it is expected that grass cover will decrease during the monitoring period. The criteria that will be used to determine the success of the Restoration Area are shown in Table 10.

Table 10. Restoration Areas Success Criteria Summary

YEAR	1	2	3	4	5	6	7	8	9	10
Stream enhancement areas will not exhibit signs of detrimental erosion or sedimentation.	x	x	x	x	x					
Survival of planted riparian trees and shrubs will exceed 90 percent	x									
Survival of planted riparian trees and shrubs will exceed 85 percent		x	x							
Survival of planted riparian trees and shrubs will exceed 80 percent				x	x					
Survival of planted riparian trees and shrubs will exceed 70 percent						x	x	x	x	x
Invasive plants on the California Invasive Plant Council (Cal-IPC) High list will not exceed five percent cover within the riparian area or re-graded bank.	x	x	x	x	x					
CRAM scores will show some improvement over baseline scores					x					x

## 6.2 Monitoring Activities

Upon completion of restoration activities, the restoration area will be monitored for a term of either 5 or 10 years. Hydrological and erosion monitoring and monitoring for non-native, invasive species will occur for 5 years, while monitoring of riparian tree plantings (yearly) and CRAM assessments (Years 3, 5, and 10) will be conducted for 10 years. The purpose for each monitoring activity, the methods for which each will be conducted by, and the specific criteria established for each is described below.

### *6.2.1 Hydrological and Erosion Monitoring for Stream Restoration*

**Purpose:** To evaluate success of stream restoration activities implemented during the implementation phase and monitor potential erosion and sedimentation that may occur as the creek approaches a state of equilibrium during the monitoring period.

**Methods:** Restored stream segments will be monitored by a qualified hydrologist to evaluate the success of stream restoration activities. A hydrologist will determine specific monitoring areas once restoration activities are complete. Most likely, hydrological cross section monitoring locations will be established at each restored step pool to monitor step pool success along. Hydrological cross section monitoring locations may also be established at other stream segments as deemed necessary to adequately monitor stream channel evolution. Additionally, qualitative monitoring for erosion, degradation, or aggradation occurring throughout Rifle Range Creek and its tributaries, Hospital and Powerhouse Creeks. Any signs of erosion, degradation, or aggradation will be evaluated to determine if the erosion is a natural part of stream evolution, or if the observed erosion poses detrimental effects to the restored creeks.

**Success Criteria:** Areas of erosion, degradation, or aggradation issues that are determined to be detrimental to the goals of the restoration will be addressed/remedied each monitoring year based on management recommendations in each annual monitoring report. If stream cross sections show that the restored stream reaches are not progressing as expected, management actions will be taken to address those issues.

### *6.2.2 Monitoring of Riparian Tree Plantings*

**Purpose:** To evaluate establishment of planted riparian trees within the Restoration Area.

**Methods:** Planted riparian trees will be monitored annually for a period of 10 years. Riparian monitoring efforts will focus on the success of plant establishment. During each monitoring visit, plant mortality and/or damage will be noted, and arrangements will be made for their replacement and/or repair. The survival of trees and shrubs will be determined by counting and assessing the health of plants in the Restoration Area. The first monitoring visit will take place in the late summer after plant installation, and then annually thereafter for a total of ten years. Survival will be based on the number of plants originally installed, and the possibility for greater than 100 percent survival exists if natural regeneration of riparian species occurs in the Restoration Area during the ten-year monitoring period. Plant growth and vigor also will be assessed and rated as good, fair, or poor. Concurrent with the annual vegetation monitoring visit, restored areas of Rifle Range Creek and its tributaries will be visually inspected for signs of excessive erosion.

**Success Criteria:** Riparian plantings will have various success criteria depending on the specific monitoring year, which the highest percentage of survival required in Year 1 and then subsequently decreasing until Year 6 as plantings become established. The survival rate for tree

and shrub plantings in Year 1 will exceed 90 percent. Years 2 and 3, the survival rate will decrease to 85 percent. For Years 4 and 5, the survival rate will exceed 80 percent. And lastly, for the Years 6 through the end of the monitoring period, the survival rate will exceed 70 percent. A summary of the percent survival criteria for each monitoring year is included in Table 11.

Table 11. Riparian Plantings Survival Criteria

Planting Type	Percent Survival Criteria			
	Year 1	Years 2-3	Years 4-5	Years 6-10
Riparian Trees and Shrubs	>90	>85	>80	>70

### 6.2.3 Quantitative CRAM Evaluations

**Purpose:** Provide quantitative evaluation of preserved streams to inform adaptive management through comparison of CRAM scores throughout the monitoring period.

**Methods:** A CRAM AA will be established at a to-be-determined location within the Rifle Range Creek Restoration Area. The CRAM AA will remain the same for all assessments during the monitoring period to enable consistent comparison of performance. Evaluation of stream restoration activities using CRAM will be led by certified CRAM practitioners trained in the riverine CRAM module. A CRAM assessment was performed in September 2015 to gather data on baseline conditions. CRAM assessments will be performed during Year 3 of the 10-Year monitoring period (following completion of restoration activities) and at Years 5 and 10. The results of these assessments will be presented as part of the annual monitoring reports for those specific years. CRAM will be conducted in conjunction with other Project monitoring activities, and will occur between February and June of each monitoring year, when plant species are most identifiable.

**Success Criteria:** CRAM scores will be compared to baseline CRAM scores for Rifle Range Creek. CRAM scores are anticipated to increase compared to baseline conditions following restoration activities. Some CRAM metric and/or submetric scores may decrease compared to baseline conditions during Year 3 of monitoring as a result of plantings not fully established and removal of non-native invasive plant species. However, these scores are anticipated to meet or exceed baseline conditions by the final Year 10 assessment. Any decrease in CRAM scores, will be reported as part of the annual monitoring report along with potential reasons for the decrease. Adaptive management strategies will also be proposed and implemented as necessary in an attempt to increase CRAM scores.

### 6.2.4 Qualitative Monitoring for Non-native, Invasive Species

**Purpose:** To monitor conditions for non-native, invasive plant species that may affect the overall health of the restoration area and its ability to provide adequate habitat functions and to identify and retreat any re-growth or new colonies prior to spreading.

**Methods:** The mitigation site will be surveyed yearly for 5 years to map and describe the occurrence of non-native, invasive species. For invasive species, the site will be surveyed for the locations of non-native, invasive species populations designated as having a severe (A) invasive impact by Cal-IPC (with the exception of annual grass species). Non-native, annual grass species will be controlled within the restoration area for 5 years, but are expected to be present due to

their prolific nature in adjacent areas. For any observed non-native invasive plant species, locations and extents of each population will be mapped, and estimates of population size (number of individuals) will be made.

Success Criteria: Non-native, invasive plant species listed as having a severe (A) invasive impact by the Cal-IPC (with the exception of annual grass species prevalent in the area) will be managed so they do not exceed more than five percent cover within the restoration area. Non-native, annual grass species will be controlled within the restoration area for the duration of the 5-Year monitoring period, but are expected to be present due to their prolific nature within adjacent lands.

Representative photographs will be taken at established photo points during each monitoring effort to document the conditions of restoration activities. And lastly, the restoration area will be evaluated for any signs of negative environmental stressors. Environmental stressors may be both anthropogenic or natural stressors and may include but are not limited to vandalism, weather, or wildlife. Any environmental stressors observed will be documented and adaptive management strategies will be proposed within the yearly monitoring reports.

### **6.3 Monitoring Schedule and Reporting Requirements**

Annual reports that discuss monitoring methodology and results will be submitted to the Corps, RWQCB, and CDFW by December 31 of each monitoring year. A qualified biologist with experience in vegetation monitoring will supervise the report preparation. These reports will assess progress in meeting success criteria and identify any problems within the restoration area. If necessary, recommendations to improve success in achieving criteria will be made. Each yearly report will summarize the monitoring activities conducted for that year and will discuss whether the specific success criteria are being met. Adaptive management strategies will be recommended for any criteria not being yet in each respective year. Representative photographs and an analysis of environmental stressors with adaptive management recommendations will also be included in each year's monitoring report. Year 5's monitoring report, however, will summarize the overall condition of the restoration area with respect to hydrological and erosion and presence of non-native, invasive species and will state whether the site meets the final success criteria for these metrics. Similarly, Year 10's monitoring report will detail whether the restoration area meets the final Year 10 success criteria for riparian plantings and CRAM scores only. A summary of the monitoring and reporting schedule is included in Table 12.

### **6.4 Notification of Completion**

In addition, to the final Year 10 annual report being submitted to the agencies, a Notice of Completion will be prepared, signed by the applicant, and submitted to the Corps, RWQCB, and CDFW to confirm successful completion of the restoration effort. Should a site visit be requested by any agency, the property owner will be notified and one will be arranged.

Table 12. Monitoring and Reporting Schedule

	Monitoring Years									
	Year 1	Year 2	Year 3	Year 4	Year 5	Year 6	Year 7	Year 8	Year 9	Year 10
<b>Quantitative Monitoring</b>										
Hydrological and Erosion	X	X	X	X	X					
CRAM			X		X					X
Riparian Plantings	X	X	X	X	X	X	X	X	X	X
<b>Qualitative Monitoring</b>										
Non-native, invasive species	X	X	X	X	X					
Photograph Documentation	X	X	X	X	X	X	X	X	X	X
Environmental Stressors	X	X	X	X	X	X	X	X	X	X
<b>Reporting Due by December 31</b>										



## **7.0 CONTINGENCY MEASURES**

If annual or final success criteria are not met, the applicant will prepare an analysis of the cause(s) of failure and, if determined necessary by the Corps, RWQCB, CDFW, propose remedial action for approval. The applicant will be responsible at that time for reasonably funding the contingency procedures necessary for completion of the restoration project.

## 8.0 LONG-TERM MANAGEMENT OF THE RESTORATION AREA

### 8.1 Long-term Maintenance Plan

The purpose of the maintenance program is to ensure the restoration areas function effectively and that the ecological values are not compromised by human disturbance, pest species invasions, or erosion. A proposed maintenance schedule for the duration of the long-term management of the restoration area is included in Table 13. Adaptive management strategies may be implemented as necessary.

Table 13. Restoration Area Long-Term Maintenance Schedule

Tasks	Riparian Corridor	Riparian Edge/ Buffer	Schedule
Inspect for and remove debris (dead vegetation and trash)	X	X	Minimum: four times per year
Inspect signs to ensure legibility and presence	X	X	Minimum: annually
Inspect for erosion on banks and on upland slopes	X	X	Minimum: after 50-year storm events
Assess need to remove non-native species	X	X	Minimum: twice annually in spring and summer
Retain all records of inspection and maintenance	X	X	Annually

#### 8.1.1 Debris Removal

Trash and other refuse shall be removed throughout the Restoration Area on an ongoing basis. Inspections and trash removal shall be conducted at least four times each year.

#### 8.1.2 Sign Inspection

All educational signs posted in the Restoration Area shall be inspected annually. If the signs become illegible, they shall be cleaned. Damaged signs shall be repaired and missing signs replaced.

#### 8.1.3 Erosion Control

Qualitative visual monitoring for structural integrity of the restored riparian corridor including creek banks and slopes shall be conducted following storm events. In the event that large flow volumes cause excessive erosion or accretion, the impacted area will be repaired immediately.

#### 8.1.4 Non-Native Plants

Maintenance of the Restoration Area will include removal of problematic non-native plant species twice each year. Removal of non-native species may be conducted by a qualified biologist or by maintenance personnel as directed by a qualified biologist.

## **8.2 Property Ownership and Management**

Oak Knoll Venture Acquisition, LLC currently owns the proposed Restoration Area, which will be established as a separate legal parcel and conveyed to a geological hazard abatement district (GHAD) subject to deed restrictions that will protect the parcel in perpetuity. Although the property will be transferred to the GHAD, Oak Knoll Venture Acquisition, LLC will remain responsible for implementing all restoration activities and the 10-year monitoring period. Upon successful completion of the monitoring period, management responsibilities will be transferred to a long-term site manager who will oversee the long-term activities in perpetuity. More detailed information regarding the long-term site manager is provided in Section 8.3.

## **8.3 Long-Term Funding Requirements**

A non-wasting endowment will be established to cover the annual maintenance costs for the duration of the long-term management of the restoration area. A detailed analysis of all maintenance activities has indicated long-term management costs are estimated at approximately \$2,976 annually. Maintenance activities included in this analysis are those listed in Table 13 and include: debris removal, sign inspections, erosion control, and non-native plant control. To generate this annual funding, approximately \$92,000 will be required as the principal payment into the established non-wasting endowment. The long-term management analysis is included as Appendix C.

## 9.0 REFERENCES

- California Department of Fish and Wildlife. Environmental Services Division (ESD). 1994. A Field Guide to Lake and Streambed Alteration Agreements, Sections 1600-1607, California Fish and Wildlife Code.
- California Regional Water Quality Control Board San Francisco Bay Region. 2015. San Francisco Bay Basin (Region 2) Water Quality Control Plan (Basin Plan). March 20, 2015.
- Department of Defense. Department of Navy. 1998. Record of Decision for the Disposal and Reuse of Naval Medical Center, Oakland, CA. Vol. 63, No. 165. August 26, 1998.
- Environmental Laboratory. 1987. Corps of Engineers Wetlands Delineation Manual. Department of the Army. Waterways Experiment Station, Vicksburg, MS 39180-0631.
- Final Environmental Impact Statement/ Environmental Impact Report (EIR/EIS) , Disposal and Reuse of Naval Medical Center, Oakland. 1998. Prepared by ERA, West. April 1998.
- Hickman, J.C. (ed.) 1993. The Jepson manual: higher plants of California. University of California Press.
- Holland, R. F. 1986. Preliminary Descriptions of the Terrestrial Natural Communities of California. Prepared for the California Department of Fish and Wildlife, Sacramento, California
- Philip Williams & Associates, Ltd. and WRA, Inc. 2006. Oak Knoll Redevelopment: Rifle Range Creek Restoration Plan. Prepared for SunCal.
- Reed, P.B., Jr. 1988. National list of plant species that occur in wetlands: California (Region 0). United States Fish and Wildlife Service Biological Report 88(26.10).
- Sawyer, J. and T. Keeler-Wolf. 1995. A Manual of California Vegetation. California Native Plant Society, Sacramento, California.
- ESA. 2007. Oak Knoll Mixed-Used Community Plan Project DRAFT Supplemental EIR.
- United States Geological Survey. 1980. Oakland east quadrangle. 7.5 minute topographic map.
- United States Department of Agriculture, Natural Resources Conservation Service, Sonoma County Field Office (USDA-NRCS). 1992. Official List of Hydric Soil Map Units for Alameda County, Western Part, California.
- United States Department of Agriculture, Soil Conservation Service. 1981. Soil Survey of Alameda County, Western Part, California. In cooperation with the University of California Agricultural Experiment Station.
- WRA, Inc. 2007. Delineation of Potential Jurisdictional Wetlands and "Other Waters" under Section 404 of the Clean Water Act. Prepared for SunCal Oak Knoll, LLC.
- WRA, Inc. 2006. Rare Plant Report. Prepared for SunCal Oak Knoll, LLC.

*Appendix A. Project Figures*

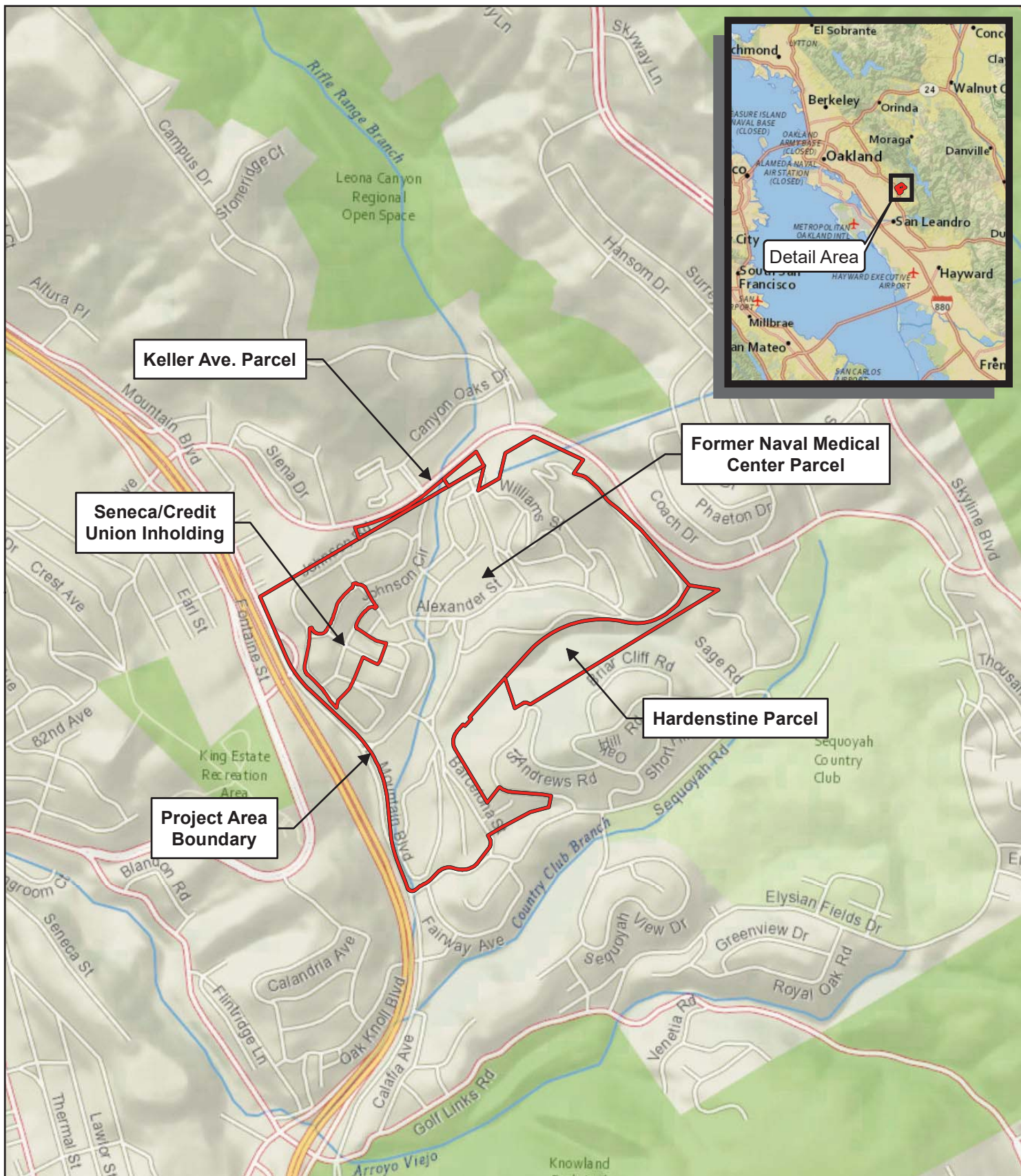
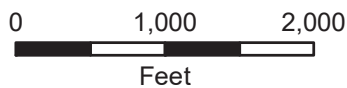


Figure 1. Location Map

**Oak Knoll Mixed Use Community Development  
Alameda County, California**

Oak Knoll Venture Acquisition LLC  
2392 Morse Avenue  
Irvine, CA 92614  
Contact: Sam Veltri  
SVeltri@SunCal.com



Map Prepared Date: 1/31/2017  
Map Prepared By: czumwalt  
Base Source: Esri, National Geographic  
Data Source(s): WRA

Figure 2.  
Overall Site Plan



Not to Scale

Map Prepared Date: 1/31/2017  
Map Prepared By: czumwalt  
Base Source:  
Data Source(s):



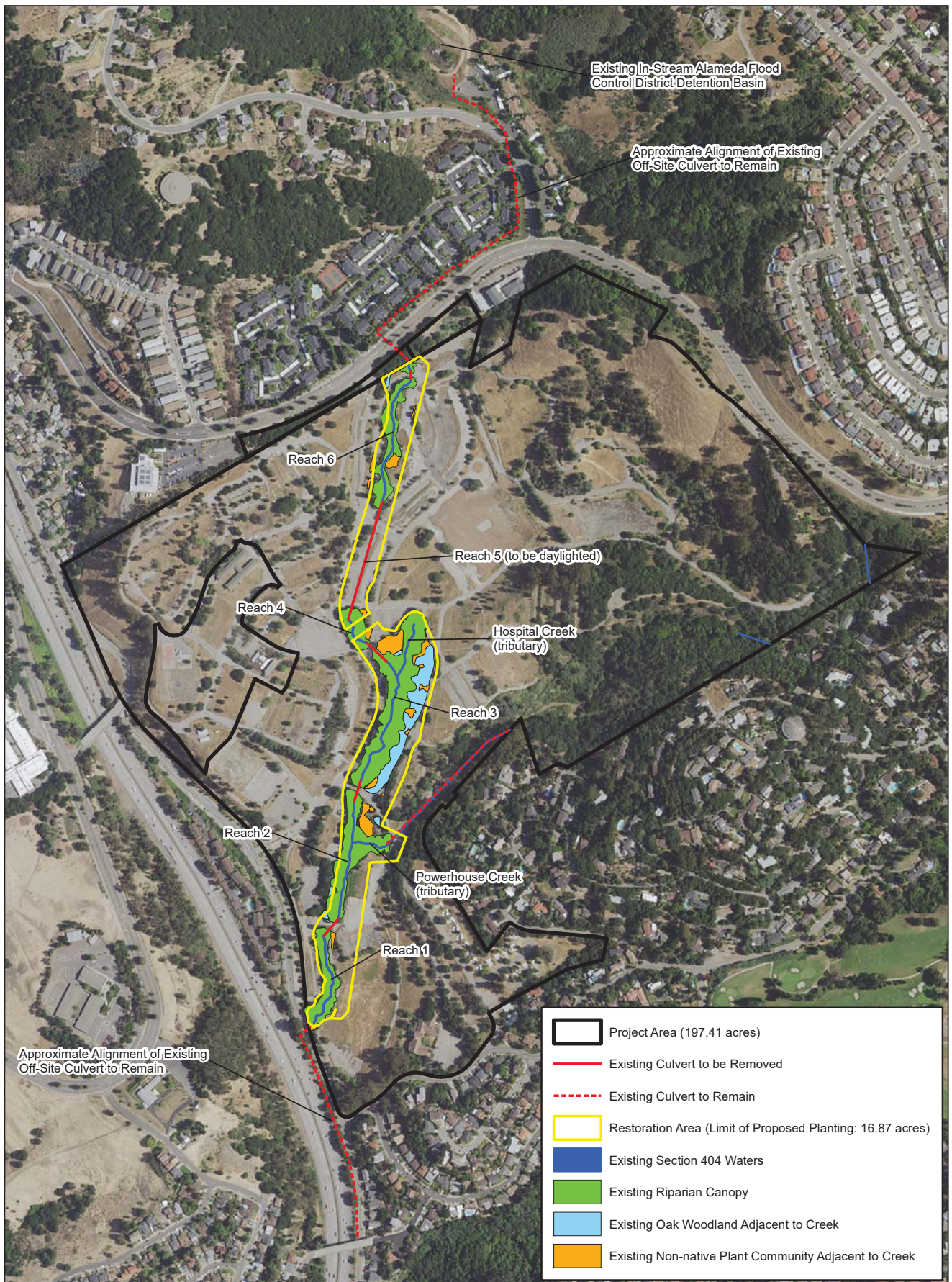
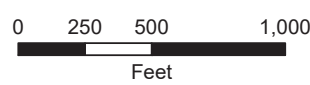


Figure 3. Creek and Riparian Overview Map

**Oak Knoll Development  
Alameda County, California**

Oak Knoll Venture Acquisition LLC  
 2392 Morse Avenue  
 Irvine, CA 92614  
 Contact: Mike Turner  
 mturner@argentmanagementllc.com



Map Prepared Date: 1/31/2017  
 Map Prepared By: czumwalt  
 Base Source: USGS EROS 2013  
 Data Source(s): WRA



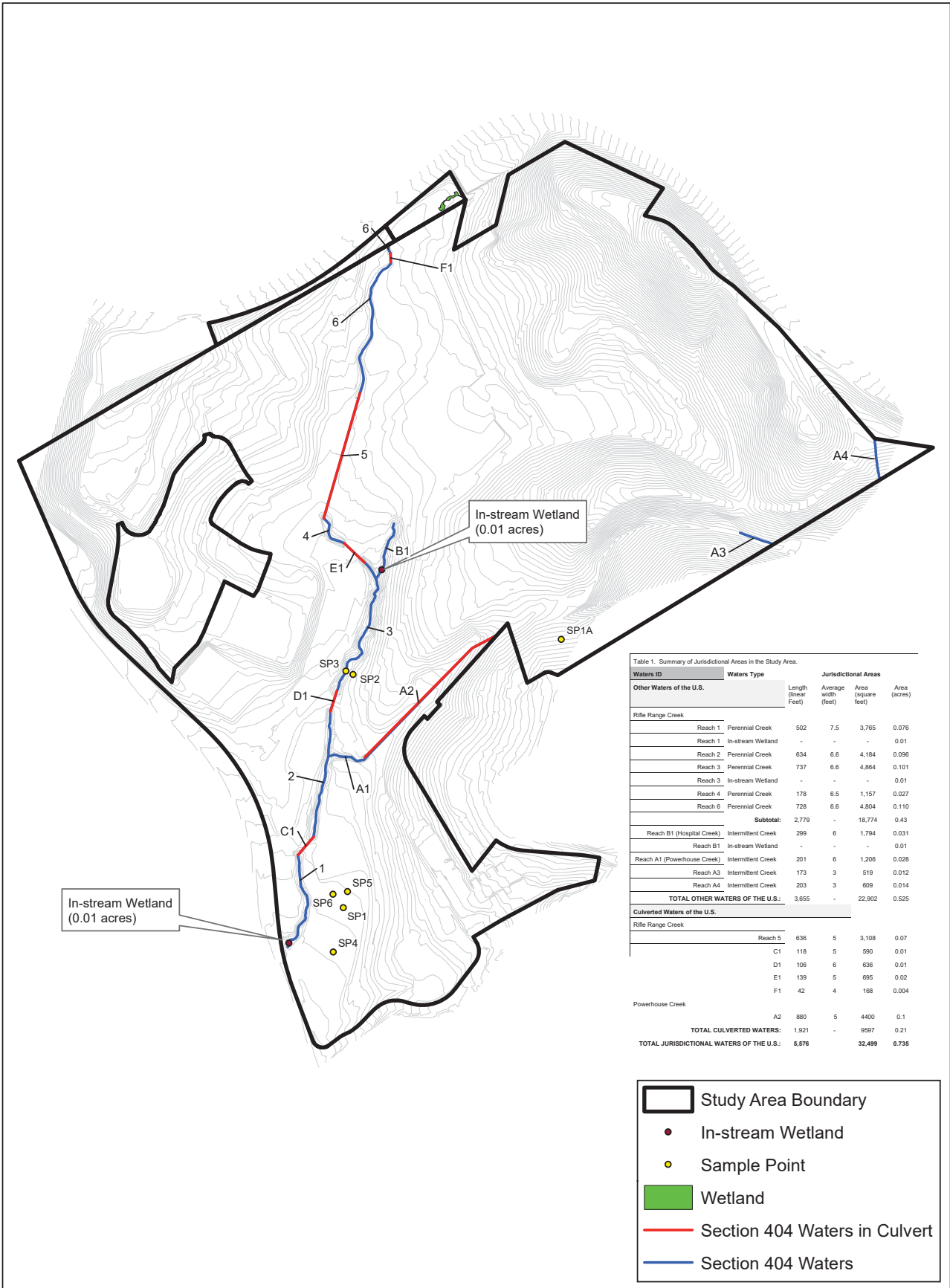
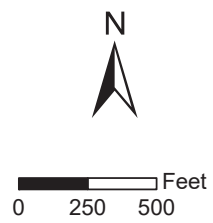


Table 1. Summary of Jurisdictional Areas in the Study Area.

Waters ID	Waters Type	Jurisdictional Areas			
		Length (linear feet)	Average width (feet)	Area (square feet)	Area (acres)
<b>Other Waters of the U.S.</b>					
Rifle Range Creek					
Reach 1	Perennial Creek	502	7.5	3,765	0.078
Reach 1	In-stream Wetland	-	-	-	0.01
Reach 2	Perennial Creek	634	6.6	4,184	0.096
Reach 3	Perennial Creek	737	6.6	4,864	0.101
Reach 3	In-stream Wetland	-	-	-	0.01
Reach 4	Perennial Creek	178	6.5	1,157	0.027
Reach 6	Perennial Creek	728	6.6	4,804	0.110
	<b>Subtotal:</b>	<b>2,779</b>	-	<b>18,774</b>	<b>0.43</b>
Reach B1 (Hospital Creek)	Intermittent Creek	299	6	1,794	0.031
Reach B1	In-stream Wetland	-	-	-	0.01
Reach A1 (Powerhouse Creek)	Intermittent Creek	201	6	1,206	0.028
Reach A3	Intermittent Creek	173	3	519	0.012
Reach A4	Intermittent Creek	203	3	609	0.014
	<b>TOTAL OTHER WATERS OF THE U.S.:</b>	<b>3,655</b>	-	<b>22,902</b>	<b>0.525</b>
<b>Culverted Waters of the U.S.</b>					
Rifle Range Creek					
	Reach 5	636	5	3,108	0.07
	C1	118	5	590	0.01
	D1	106	6	636	0.01
	E1	139	5	695	0.02
	F1	42	4	168	0.004
Powerhouse Creek					
	A2	860	5	4,400	0.1
	<b>TOTAL CULVERTED WATERS:</b>	<b>1,921</b>	-	<b>9,567</b>	<b>0.21</b>
	<b>TOTAL JURISDICTIONAL WATERS OF THE U.S.:</b>	<b>5,576</b>	-	<b>32,499</b>	<b>0.735</b>

Figure 4. Jurisdictional Wetlands and Waters of the U.S.  
Oak Knoll Mixed Use Community Development  
Alameda County, California



Date: January 2017  
Map By: Chris Zumwalt  
Data: WRA, Inc.

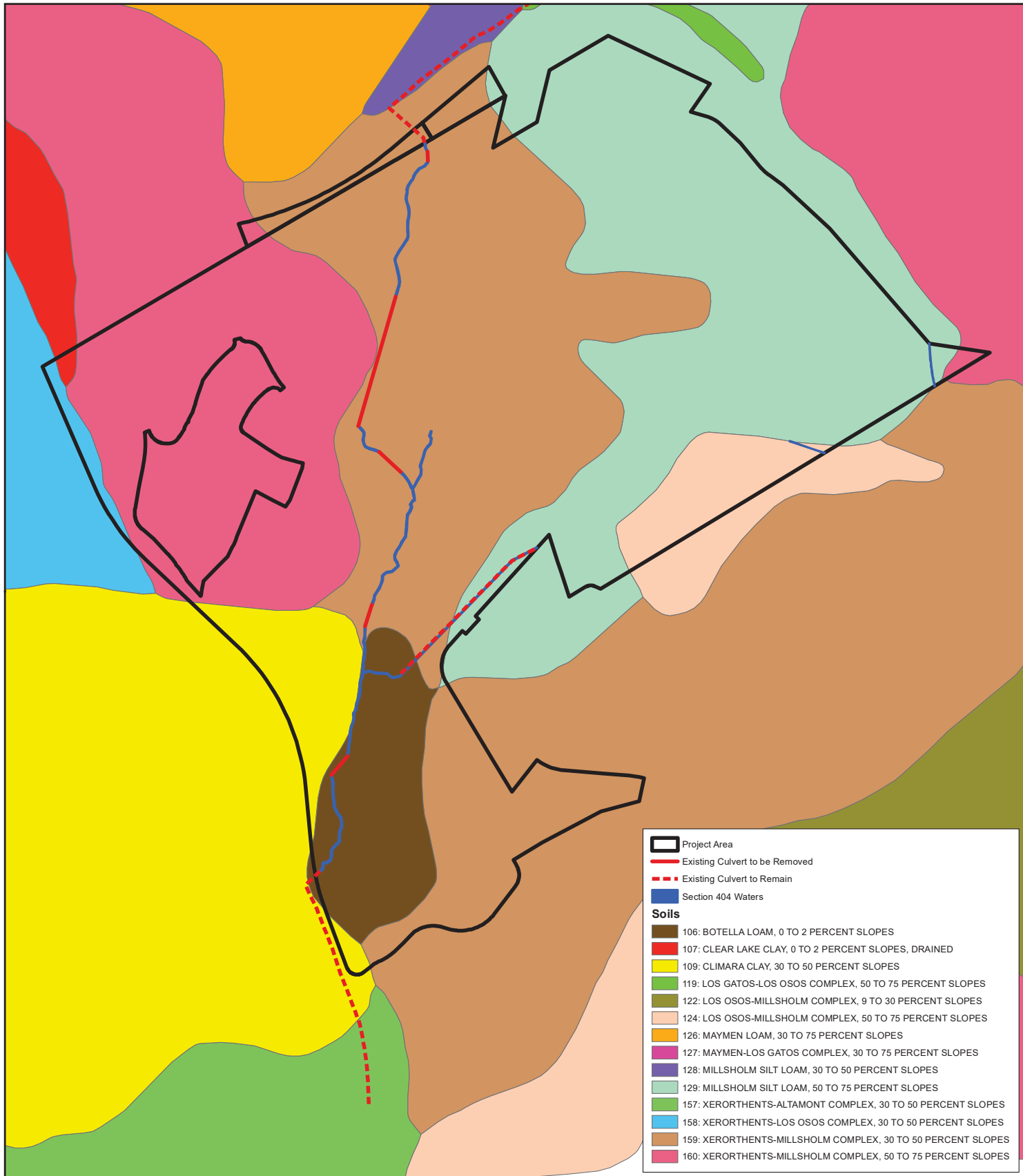
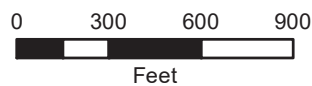


Figure 5. Soils Map

Oak Knoll Mixed Use Community Development  
Alameda County, California

Oak Knoll Venture Acquisition LLC  
2392 Morse Avenue  
Irvine, CA 92614  
Contact: Mike Turner  
mturner@argementmanagementllc.com



Map Prepared Date: 1/31/2017  
Map Prepared By: czumwalt  
Base Source: Esri, National Geographic  
Data Source(s): WRA; SSURGO soil survey

*Appendix B. Existing Rifle Range Creek Channel Corridor Geomorphic Reconnaissance*

## *Existing Rifle Range Creek Channel Corridor Geomorphic Reconnaissance*

Rifle Range Creek, a perennial stream, flows from northeast to southwest through the middle of the Project Area. The daylighted (aboveground) portion of the creek within the Project Area is approximately 2,779 feet long and averages 6.8 feet in width. The creek width was defined by the ordinary high water (OHW) mark which was identified using wracks of vegetative material, scouring and shelving along banks, and sediment stains on vegetation. Each reach consists of a mix of riffles, runs, and pools; therefore, stream width and area calculations are based on an average of dimensions for these features. Patches of wetland vegetation were present within some channel segments, but the stream channels were primarily observed to be non-vegetated Waters of the United States, functioning to convey water rather than to pond it. Banks above the OHW mark were generally steep and vegetated by riparian plant species. Much of the creek bed has been lined with crushed rock about six to 12 inches in diameter, held in place by chain-link fence material staked flat against the rocks, to minimize erosion and shifting of the channel. Trees and other vegetation form a canopy over the creek and its tributaries for most of their length. Rifle Range Creek has been divided into six reaches on the delineation map, numbered 1 to 6 from downstream to upstream, for ease of reference.

### **Reach 1**

Reach 1 is within the lower portion of Rifle Range Creek and extends upstream from the box culvert inlet at Mountain Boulevard to the culverted road crossing near the tennis court.

The channel has down-cut into the landscape. As a result, the slopes adjacent to the creek have become unstable in places, as evidenced by recent and historic slope failure scars (e.g. landslides, slumps, and earthflows). Downcutting has been temporarily arrested in at least one location by a natural headcut feature. However, vertical headcuts still exist along the channel indicating that the channel remains unstable.

Vegetation along the channel includes many large, dead, or dying mature trees and dense invasive weeds. The absence of a debris barrier structure has allowed woody debris to collect in places within the channel.

Existing infrastructure features along the channel and adjacent hillslopes include a chain-link fence, spanning pipe support structures, and storm drain outlets. In some locations, infrastructure features have deteriorated and slope failures have undercut the edge of the adjacent road.

### **Reach 2**

Reach 2 of Rifle Range Creek extends approximately 634 feet upstream of Reach 1 from the tennis court road culvert to Pool Road. The lower third of this reach has down-cut considerably. Backwater deposits were noted upstream of the culvert, implying this culvert may be undersized. Hillslopes adjacent to this portion of the creek are unstable on both sides of the channel, as evidenced by numerous recent and historic slope failure scars. The creek is straight in this lower section, and

sediment deposits associated with slope failures are not present, implying that deposits have been transported downstream. Vegetation in this lower section is similar to Reach 1.

The middle third of Reach 2 consists of a number of step-pool structures formed by failing rip-rap boulders, tree roots, woody debris, and concrete blocks. These step pools control the local channel gradient and act as a transition between the downcut lower section and the less incised upper section. There are approximately 16 to 20 feet of vertical relief that is achieved in this section. The long-term stability of this section is controlled by the existing step structures; modification of these structures could destabilize the channel.

Powerhouse Creek enters Reach 2 in the step-pool section. The condition of Rifle Range Creek near this tributary confluence suggests that the tributary is destabilizing Rifle Range Creek. The runoff into Rifle Range Creek from the tributary has significantly increased relative to natural conditions.

A remnant floodplain terrace feature can be observed downstream of the confluence with Powerhouse Creek. The terrace is over nine feet above the existing channel bottom, implying that about six to seven feet of down-cutting has occurred at this location. Hillslope failures at several locations have been caused by large woody debris pieces within this section of Reach 2.

The upper third of Reach 2 is relatively stable as evidenced by the lack of downcutting. The adjacent hillslopes are also relatively stable. Vegetation is denser in this section, and the tree canopy begins to form a closed cover overhead.

Several existing infrastructure features exist along the channel and adjacent hillslopes in Reach 2, some in deteriorated condition. Deteriorated features include a failing spanning pipe and associated support structures, rip-rap, other bank armoring features, and five storm drain outlets.

### **Reach 3**

Reach 3 runs approximately 737 feet between Pool Street and a parking lot near the intersection of Alexander and Blackwood Streets. In the lower section of this reach, the channel meanders across a floodplain that is approximately 40 feet wide. The upper portion of the reach splits into the main channel (Reach 4) to the north, and a tributary (Hospital Creek) to the east.

The upper section has a slightly greater sinuosity, but does not have a well-defined floodplain. This implies that the channel has a down-cut into its current position from a relatively low-gradient channel form. Hillslopes throughout this reach are steep and long.

Several existing infrastructure features exist along the channel and adjacent hillslopes in Reach 3, some in failing condition. These include rip-rap and other bank armoring features, and a spanning pipe with supports. One small drain outlet occurs at the upper end of Reach 3.

#### **Reach 4**

Reach 4 is located in a small patch of wooded land between Blackwood Street and Crowley Street. The reach runs approximately 178 feet and is deeply incised.

A large stormwater drain feeds into the upper portion of this reach. The stormwater drain map suggests that a large proportion of the adjacent developed area drains to this section of the creek, and is probably responsible for the channel incision. Side slopes are generally unstable, and several recent and historic slope failure scars are evident.

At the upstream end of Reach 4, the concrete headwall is being undercut by runoff draining from the adjacent parking lot.

#### **Reach 5**

Reach 5 is an approximately 636-foot-long reach of Rifle Range Creek contained within a culvert.

#### **Reach 6**

Reach 6 extends from the main hospital parking lot upstream to the property boundary. This reach is stable due to gabions that line the lower portion of both banks all along this reach, and extend into the channel bed. In places, the gabion baskets have failed due to tree roots that have pried open the baskets. The health of numerous mid-sized trees on this reach has been negatively impacted due to insufficient rooting depth associated with the gabions.

*Appendix C. Long-Term Management Analysis*

Endowment Summary	
<b>Management Costs</b>	<b>\$ 2,705</b>
Administrative Rate	10%
<b>Total Annual Costs</b>	<b>\$ 2,976</b>
Capitalization Rate	3.25%
<b>Total Endowment</b>	<b>\$ 91,564.00</b>



Management Plan Task #	Task Group	Task Description	Rates*			Equipment/ Supply Costs		Frequency (years between occurrences)	Contingency	Total	Assumptions
			50 Land Manager	120 Biologist	30 Laborer	Units	Rate				
9.1.1	Debris Removal	Collect and remove trash and other refuse from restored riparian corridor	1.0	-	1.0	-		1/4	10%	\$ 352.00	Land Manager will coordinate quarterly patrols of restored riparian corridor to correct litter issues. At 2.5 mph walking speed, 16 acre site can be visually monitored in approximately 2 hours, and occur concurrent to sign inspection.
9.1.2	Sign Inspection	Inspect and clean educational signs	1.0	-	-	-		1	10%	\$ 55.00	Six educational signs will be posted throughout the restored riparian corridor. Signs will be inspected during the annual walk-through site inspection and cleaned as needed.
9.1.2	Sign Inspection	Replace and repair educational signs	-	-	12.0	6	\$300.00	10	15%	\$ 248.40	Each of the six signs will be replaced approximately every 10 years, and require 2 hours to install.
9.1.3	Erosion Control	Visually monitor restored riparian corridor for excessive erosion after storm events	-	0.5	-	1	\$100.00	1/2	10%	\$ 352.00	One biologist walking 2 mph can monitor the 4,333 LF of stream in roughly 1/2 hour. One GPS needed. Assume two storm events per year.
9.1.4	Non-native Plants	Monitor for problematic non-native species	-	2.0	-	1	\$100.00	1/2	10%	\$ 748.00	One biologist walking 2.5 mph can monitor 16 acres in approximately 2 hours. Monitoring will occur twice annually, in spring and summer. One GPS unit needed.
9.1.4	Non-native Plants	Remove non-native problematic species as needed	-	-	4.0	-		1/2	15%	\$ 276.00	Problematic non-native species will be removed prior to restoration, so significant removal is not anticipated. Hand removal required due to riparian habitat (i.e., no mowing or herbicide use).
Various	Travel	Travel Time	-	1.0	-	-		1/4	15%	\$ 552.00	50 miles round trip from San Rafael, 4 trips per year.
Various	Travel	Travel	-	-	-	50	\$0.53	1/4	15%	\$ 121.90	50 miles round trip from San Rafael, 4 trips per year.
<b>Total</b>			<b>2.0</b>	<b>3.5</b>	<b>17.0</b>					<b>\$ 2,705.30</b>	

**Appendix D**  
Supplemental Biological  
Resources Assessment –  
Keller Avenue and EBMUD  
Parcels (March 2017)

---

# Biological Resources Assessment

Keller Avenue and EBMUD Parcels  
(APNs: 37A-3152-8 & 37A-3152-9)  
OAKLAND, ALAMEDA COUNTY, CALIFORNIA

---

**Prepared For:**

Oak Knoll Venture Acquisition LLC  
2392 Morse Avenue  
Irvine, California 92614

**WRA Contacts:**

Amanda McCarthy  
[mccarthy@wra-ca.com](mailto:mccarthy@wra-ca.com)

Kari Dupler  
[dupler@wra-ca.com](mailto:dupler@wra-ca.com)

**Date:**

March 2017

**WRA Project Number:**

15103-5



## TABLE OF CONTENTS

EXECUTIVE SUMMARY .....	iv
1.0 INTRODUCTION.....	1
1.1.1 Study Area History .....	1
2.0 REGULATORY BACKGROUND .....	3
2.1 Sensitive Biological Communities .....	3
2.2 Local Policies, Ordinances, and Regulations .....	4
2.3 Special-Status Species.....	5
2.4 Other Regulatory Issues .....	6
3.0 METHODS.....	8
3.1 Biological Communities .....	8
3.1.1 Non-sensitive Biological Communities.....	8
3.1.2 Sensitive Biological Communities.....	8
3.2 Special-Status Species.....	9
3.2.1 Literature Review .....	9
3.2.2 Site Assessment .....	9
4.0 RESULTS .....	11
4.1 Biological Communities .....	11
4.1.1 Non-Sensitive Biological Communities .....	14
4.1.2 Sensitive Biological Communities.....	14
4.2 Special-Status Species.....	15
4.2.1 Plants.....	15
4.2.2 Wildlife .....	17
5.0 POTENTIAL IMPACTS, AVOIDANCE, MINIMIZATION, AND MITIGATION MEASURES..	23
5.1 Project Description .....	23
5.2 Significance Threshold Criteria .....	27
5.3 Potentially Significant Impacts .....	28
5.4 Mitigation Measures .....	31
6.0 REFERENCES .....	34

## LIST OF APPENDICES

- Appendix A – List of Observed Plant Species
- Appendix B – Potential for Special-Status Species to Occur in the Study Area
- Appendix C – Site Photographs

## LIST OF TABLES

Table 1. Description of CNPS Ranks and Threat Codes .....	5
Table 2. Description of East Bay CNPS Rare Plant Rankings .....	6
Table 3. Summary of Biological Communities in the Study Area .....	12
Table 4. Impacts to Waters of the United States within the Study Area .....	28
Table 5. Existing and Proposed Habitats in the Restoration Area.....	29

## LIST OF FIGURES

Figure 1. Study Area Location Map .....	2
Figure 2. Biological Communities in the Study Area .....	13
Figure 3. Special-Status Plant Species within 5 miles of the Project Area .....	16
Figure 4. Special-Status Wildlife Species within 5 miles of the Project Area.....	18
Figure 5. Site Plan .....	25
Figure 6. Creek and Riparian Overview Map.....	26

## LIST OF PREPARERS

Amanda McCarthy, PhD PWS, Principal-in-Charge  
Kari Dupler, MS, Wetland Biologist, Project Manager

## LIST OF ACRONYMS AND ABBREVIATIONS

AWS	Alameda whipsnake
CCR	California Code of Regulations
CDFG	California Department of Fish and Game
CDFW	California Department of Fish and Wildlife
CEQA	California Environmental Quality Act
CESA	California Endangered Species Act
CFGC	California Fish and Game Code
CFR	Code of Federal Regulations
CNDDDB	California Natural Diversity Database
CNPS	California Native Plant Society
Corps	U.S. Army Corps of Engineers
ESA	Federal Endangered Species Act
Inventory	CNPS Inventory of Rare and Endangered Plants
OWHM	Ordinary High Water Mark
Rank	California Rare Plant Rank
RWQCB	Regional Water Quality Control Board
SWPPP	Stormwater Pollution Prevention Plan
USDA	U.S. Department of Agriculture
USFWS	U.S. Fish and Wildlife Service
WRA	WRA, Inc.

## EXECUTIVE SUMMARY

The purpose of this report is to provide an analysis of potential impacts to biological resources, including sensitive natural communities and special-status species within the two parcels totaling approximately 2.42 acres along Keller Avenue (Study Area) (APNs: 37A-3152-8 and 37A-3152-9) in the City of Oakland, Alameda County, California. This report serves as an addendum to the Biological Resources Assessment (BRA) prepared for the adjacent Oak Knoll Mixed Use Community Development Project (WRA 2015a).

WRA, Inc. (WRA) visited the Study Area on January 23, 2017, and identified five biological communities in the Study Area, of which, three are considered sensitive. Sensitive biological communities in the Study Area include riparian woodland, coast live oak woodland, and perennial/intermittent stream. Impacts to sensitive and/or regulated biological communities and resources would require the following permits/approvals:

- U.S. Army Corps of Engineers (Corps) Section 404 permit for any impacts below the ordinary high water mark (OHWM) of streams in the Study Area;
- Regional Water Quality Control Board (RWQCB) Section 401 Water Quality Certification for any impacts below the top of bank of streams in the Study Area;
- California Department of Fish and Wildlife Section 1602 Lake and Streambed Alteration Agreement for any impacts within the top-of-bank of streams and/or the outer drip line of associated riparian vegetation in the Study Area;
- City of Oakland (City) Tree Removal Permit for removal of any protected trees in the Study Area; and,
- City Creek Protection Permit for work within 20 feet of the top of bank of any protected stream in the Study Area.

No special-status wildlife species were observed in the Study Area during the site assessment. Six special-status wildlife species have a moderate or high potential to occur in the Study Area. Special-status wildlife species which have a high or moderate potential to occur in the Study Area include: Nuttall's woodpecker (*Picoides nuttallii*), oak titmouse (*Baeolophus inornatus*), San Francisco dusky-footed woodrat (*Neotoma fuscipes annectens*), yellow warbler (*Setophaga petechia*), olive-sided flycatcher (*Contopus cooperi*), and Allen's hummingbird (*Selasphorus sasin*).

A detailed analysis of potential impacts to sensitive biological communities and special-status species is included in Section 5 of this report, as are suggested mitigation measures. With implementation of mitigation measures, all impacts are considered less than significant under the California Environment Quality Act (CEQA).

## 1.0 INTRODUCTION

On January 23, 2017, WRA, Inc. performed a tree survey and wetland delineation within the two parcels along Keller Avenue (APNs: 37A-3152-8 and 37A-3152-9). These two parcels comprise approximately 2.42 acres. This area, together with the Hardenstein Parcel and Former Naval Medical Center Parcel, which are collectively approximately 188 acres, form the Former Naval Medical Center Parcel (Project Area) in Oakland, Alameda County, California (Figure 1). The Study Area is located in an urban area that consists of a patchwork of developed residential and commercial areas interspersed with undeveloped, open areas and regional open space. Rifle Range Creek, a tributary of Arroyo Viejo, flows from north to south from an outfall located within the Keller Avenue parcel into the adjacent Former Naval Medical Center Parcel.

The purpose of the assessment was to gather information necessary to complete a review of biological resources under the California Environmental Quality Act (CEQA). This report describes the results of the site visit, which assessed the Study Area for the presence of sensitive biological resources protected by local, state, and federal laws and regulations. If special-status species were observed during the site visit, they were recorded. Specific findings on the habitat suitability or presence of special-status species or sensitive habitats may require that protocol-level surveys be conducted. This report also contains an evaluation of potential impacts to special-status species and sensitive biological resources that may occur as a result of the proposed project and potential mitigation measures to compensate for those impacts. This report serves as an addendum to the original BRA (WRA 2015a) prepared for the Oak Knoll Mixed Use Development Project Area.

A biological resources assessment provides general information on the potential presence of sensitive species and habitats. The biological assessment is not an official protocol-level survey for listed species that may be required for project approval by local, state, or federal agencies. This assessment is based on information available at the time of the study and on site conditions that were observed on the date of the site visit.

### *1.1.1 Study Area History*

The Study Area consists of approximately 2.42-acres on two parcels (EBMUD parcel; APN: 37A-3152-9 and Keller Avenue parcel; APN: 37A-3152-8) located adjacent to the Former Naval Medical Center Parcel (APN: 043A-4675-3-21) in the Oakland Hills region of Alameda County, California (Figure 1). The Study Area is bordered to the north by Keller Avenue, to the northeast and southwest by commercial development, and the south by the Former Naval Medical Center Parcel. The Keller Avenue parcel is divided by Williams Street, which historically provided access to the adjacent parcel. These two parcels have largely served as utility and road right-of-way corridors, but have experienced historical impacts from adjacent development.



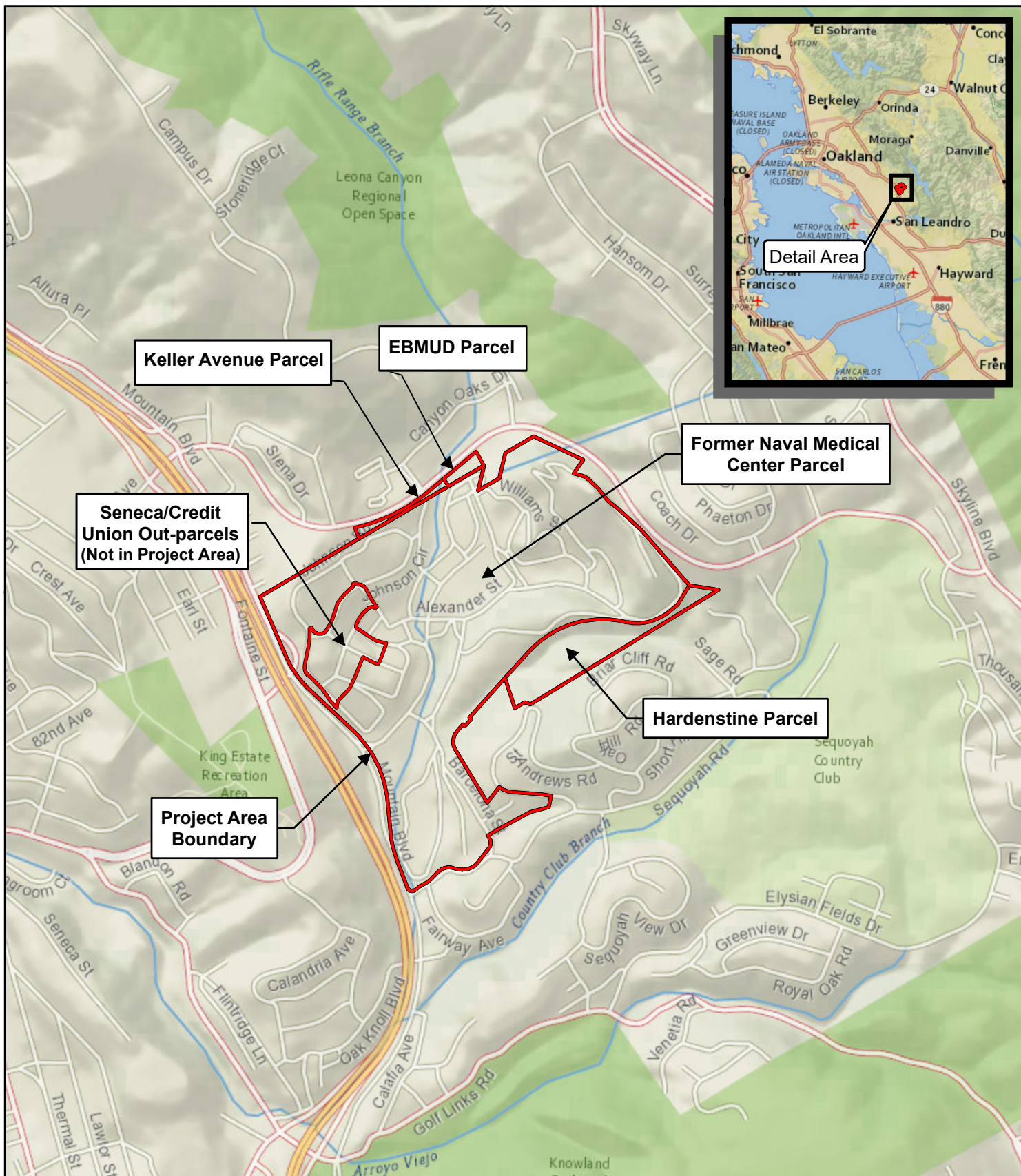
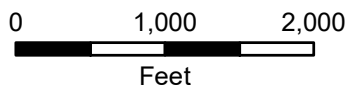


Figure 1. Location Map

**Oak Knoll Mixed Use Community Development  
Alameda County, California**

Oak Knoll Venture Acquisition LLC  
2392 Morse Avenue  
Irvine, CA 92614  
Contact: Sam Veltri  
SVeltri@SunCal.com



ENVIRONMENTAL CONSULTANTS

Map Prepared Date: 1/31/2017  
Map Prepared By: czumwalt  
Base Source: Esri, National Geographic  
Data Source(s): WRA

## 2.0 REGULATORY BACKGROUND

The following sections explain the regulatory context of the biological assessment, including applicable laws and regulations that were applied to the field investigations and analysis of potential project impacts.

### 2.1 Sensitive Biological Communities

Sensitive biological communities include habitats that fulfill special functions or have special values, such as wetlands, streams, or riparian habitat. These habitats are protected under federal regulations such as the Clean Water Act; state regulations such as the Porter-Cologne Act, the CDFW Streambed Alteration Program, and CEQA; or local ordinances or policies such as city or county tree ordinances, Special Habitat Management Areas, and General Plan Elements.

#### Waters of the United States

The U.S. Army Corps of Engineers (Corps) regulates “Waters of the United States” under Section 404 of the Clean Water Act (CWA). Waters of the U.S. are defined in the Code of Federal Regulations (CFR) as waters susceptible to use in commerce, including interstate waters and wetlands, all other waters (intrastate waterbodies, including wetlands), and their tributaries (33 CFR 328.3). Potential wetland areas, according to the three criteria used to delineate wetlands as defined in the *Corps of Engineers Wetlands Delineation Manual* (Environmental Laboratory 1987), are identified by the presence of (1) hydrophytic vegetation, (2) hydric soils, and (3) wetland hydrology. Areas that are inundated at a sufficient depth and for a sufficient duration to exclude growth of hydrophytic vegetation are subject to Section 404 jurisdiction as “other waters” and are often characterized by an ordinary high water mark (OHWM). Other waters, for example, generally include lakes, rivers, and streams. The placement of fill material into Waters of the U.S generally requires an individual or nationwide permit from the Corps under Section 404 of the Clean Water Act.

#### Waters of the State

The term “Waters of the State” is defined by the Porter-Cologne Act as “any surface water or groundwater, including saline waters, within the boundaries of the state.” The Regional Water Quality Control Board (RWQCB) protects all waters in its regulatory scope and has special responsibility for wetlands, riparian areas, and headwaters. These waterbodies have high resource value, are vulnerable to filling, and are not systematically protected by other programs. RWQCB jurisdiction includes “isolated” wetlands and waters that may not be regulated by the Corps under Section 404. Waters of the State are regulated by the RWQCB under the State Water Quality Certification Program which regulates discharges of fill and dredged material under Section 401 of the CWA and the Porter-Cologne Water Quality Control Act. Projects that require a Corps permit, or fall under other federal jurisdiction, and have the potential to impact Waters of the State, are required to comply with the terms of the Water Quality Certification determination. If a proposed project does not require a federal permit, but does involve dredge or fill activities that may result in a discharge to Waters of the State, the RWQCB has the option to regulate the dredge and fill activities under its state authority in the form of Waste Discharge Requirements.

#### Streams, Lakes, and Riparian Habitat

Streams and lakes, as habitat for fish and wildlife species, are subject to jurisdiction by CDFW under Sections 1600-1616 of California Fish and Game Code (CFGF). Alterations to or work

within or adjacent to streambeds or lakes generally require a 1602 Lake and Streambed Alteration Agreement. The term “stream”, which includes creeks and rivers, is defined in the California Code of Regulations (CCR) as “a body of water that flows at least periodically or intermittently through a bed or channel having banks and supports fish or other aquatic life [including] watercourses having a surface or subsurface flow that supports or has supported riparian vegetation” (14 CCR 1.72). In addition, the term “stream” can include ephemeral streams, dry washes, watercourses with subsurface flows, canals, aqueducts, irrigation ditches, and other means of water conveyance if they support aquatic life, riparian vegetation, or stream-dependent terrestrial wildlife (CDFG 1994). “Riparian” is defined as “on, or pertaining to, the banks of a stream.” Riparian vegetation is defined as “vegetation which occurs in and/or adjacent to a stream and is dependent on, and occurs because of, the stream itself” (CDFG 1994). Removal of riparian vegetation also requires a Section 1602 Lake and Streambed Alteration Agreement from CDFW.

### Other Sensitive Biological Communities

Other sensitive biological communities not discussed above include habitats that fulfill special functions or have special values. Natural communities considered sensitive are those identified in local or regional plans, policies, regulations, or by the CDFW. CDFW ranks sensitive plant communities (or “vegetation alliances”) as “threatened” or “very threatened” and keeps records of their occurrences in its California Natural Diversity Database (CNDDDB; CDFW 2015). Sensitive plant communities are also identified by CDFW (CNPS 2015a). CNDDDB vegetation alliances are ranked 1 through 5 based on NatureServe’s (2010) methodology, with those alliances ranked globally (G) or statewide (S) as 1 through 3 considered sensitive. Impacts to sensitive natural communities identified in local or regional plans, policies, or regulations or those identified by the CDFW or USFWS must be considered and evaluated under CEQA (CCR Title 14, Div. 6, Chap. 3, Appendix G). Specific habitats may also be identified as sensitive in city or county general plans or ordinances.

## **2.2 Local Policies, Ordinances, and Regulations**

### City of Oakland Tree Protection Ordinance

The City of Oakland Municipal Code, Chapter 12.36, “Protected Trees” (Tree Ordinance), establishes regulations for the protection and preservation of native and non-native trees in the City of Oakland. The ordinance defines a “protected tree” on any property within City limits, as any coast live oak (*Quercus agrifolia*) measuring four inches DBH or larger, and any other species measuring nine inches DBH or larger, except eucalyptus (*Eucalyptus* spp.) or Monterey pine (*Pinus radiata*). It is unlawful to remove a protected tree as defined above except as provided for in Section 12.36.140 (Exemptions) without obtaining a tree removal permit. The owner of property upon which a protected tree is located may request to remove protected trees not otherwise exempt from the Tree Ordinance by filling an application for a Tree Removal Permit. As described above, eucalyptus trees are not protected and removal does not require a tree removal permit. Monterey pine trees are also not protected; however, their identification must be verified by City staff prior to removal.

### City of Oakland Creek Protection Ordinance

The City of Oakland Municipal Code, Chapter 13.16, “Creek Protection, Storm Water Management and Discharge Control” (Ord. 12024 § 1 (part), 1997), establishes regulations for the protection of creeks and riparian corridors and enhancement of the water quality of watercourses, water bodies, and wetlands within the City in a manner pursuant to and consistent with the federal Clean Water Act. The Ordinance defines a creek as any naturally occurring creek

or engineered channel as identified on the “Watershed Map of Oakland and Berkeley Area”, published by the Oakland Museum of California (Sowers 2000). Rifle Range Creek, which flows from north to south across the Study Area, is identified on the aforementioned map. A Creekside Property is defined as any property within City limits containing a creek or riparian corridor crossing the property. As per the Ordinance, a Creek Protection Permit and Creek Protection Plan may be required prior to development or work on a Creekside Property. If work is conducted within a creek setback (within 20 feet of the top of bank), a hydrology report may be required as well.

### 2.3 Special-Status Species

Special-status species include those plants and wildlife species that have been formally listed, are proposed as endangered or threatened, or are candidates for such listing under the Federal Endangered Species Act (ESA) or California Endangered Species Act (CESA). These acts afford protection to both listed species and those that are formal candidates for listing. In addition, California Department of Fish and Wildlife (CDFW) Species of Special Concern, which are species that face extirpation in California if current population and habitat trends continue, U.S. Fish and Wildlife Service (USFWS) Birds of Conservation Concern, and CDFW special-status invertebrates, are all considered special-status species. Although CDFW Species of Special Concern generally have no special legal status, they are given special consideration under the California Environmental Quality Act (CEQA). In addition to regulations for special-status species, most birds in the United States, including non-special-status native species, are protected by the Migratory Bird Treaty Act of 1918 (MBTA) and the California Fish and Game Code (CFGC), i.e., sections 3503, 3503.5 and 3513. Under these laws, destroying active bird nests, eggs, and/or young is illegal.

Plant species on the California Native Plant Society (CNPS) Rare and Endangered Plant Inventory (Inventory) with California Rare Plant Ranks (Rank) of 1 and 2 are also considered special-status plant species and must be considered under CEQA. Rank 3 and Rank 4 species are afforded little or no protection under CEQA, but are included in this analysis for completeness. A description of the CNPS Ranks is provided below in Table 1.

Table 1. Description of CNPS Ranks and Threat Codes

California Rare Plant Ranks (formerly known as CNPS Lists)	
Rank 1A	Presumed extirpated in California and either rare or extinct elsewhere
Rank 1B	Rare, threatened, or endangered in California and elsewhere
Rank 2A	Presumed extirpated in California, but more common elsewhere
Rank 2B	Rare, threatened, or endangered in California, but more common elsewhere
Rank 3	Plants about which more information is needed - A review list
Rank 4	Plants of limited distribution - A watch list
Threat Ranks	
0.1	Seriously threatened in California
0.2	Moderately threatened in California
0.3	Not very threatened in California

## Locally Rare, Unusual, and Significant Plants

*Rare, Unusual and Significant Plants of Alameda and Contra Costa Counties, Eighth Edition* (Lake 2010) is a document produced by the East Bay Chapter of the CNPS that lists 608 plant taxa which are considered locally rare, unusual, or significant in Alameda and Contra Costa counties. Of these 608 species, 313 occur in two or fewer regions in Alameda and Contra Costa counties (ranked A1 in the East Bay), 231 occur in five or fewer regions in the two counties or are otherwise threatened (ranked A2 in the East Bay), and 64 are only known from the area historically and are presumed to have been extirpated from the East Bay during the last 100 year (A1x) [see Table 2 below]. A-ranked species receive consideration under sections 15380 and 15125(c) of the CEQA and are considered “locally rare” for the purposes of this report. Any locally rare species observed in the Study Area are discussed in this report.

Table 2. Description of East Bay CNPS Rare Plant Rankings

Rank	Description
A1	Species occurring in two or fewer regions in Alameda and Contra Costa counties
A1x	Species presumed extirpated from Alameda and Contra Costa counties
A1?	Species possibly occurring in Alameda and Contra Costa counties. Identification or location is uncertain
A2	Plants occurring in three to five regions or are otherwise threatened in Alameda and Contra Costa counties.
B	Species occurring in six to nine regions or are otherwise threatened in Alameda and Contra Costa counties (high priority watch list).
C	Species occurring in 10 to 15 regions or are otherwise threatened in Alameda and Contra Costa counties (second priority watch list).

\*Ranks preceded by an asterisk (e.g. “\*A1”) also have a statewide rarity ranking.

\*Species on the watch lists (ranks B and C) are not considered to be special-status based on the CEQA guidelines.

### Critical Habitat

Critical habitat is a term defined in the ESA as a specific geographic area that contains features essential for the conservation of a threatened or endangered species and that may require special management and protection. The ESA requires federal agencies to consult with the USFWS to conserve listed species on their lands and to ensure that any activities or projects they fund, authorize, or carry out will not jeopardize the survival of a threatened or endangered species. In consultation for those species with critical habitat, federal agencies must also ensure that their activities or projects do not adversely modify critical habitat to the point that it will no longer aid in the species’ recovery. In many cases, this level of protection is similar to that already provided to species by the ESA jeopardy standard. However, areas that are currently unoccupied by the species but which are needed for the species’ recovery are protected by the prohibition against adverse modification of critical habitat.

## **2.4 Other Regulatory Issues**

### Sudden Oak Death

The United States Department of Agriculture (USDA) restricts the interstate movement of certain regulated and restricted articles from quarantined areas in California and Oregon to prevent the spread of *Phytophthora ramorum*, the organism that causes Sudden Oak Death (SOD) (7 CFR

Part 301). Within California, transport of regulated and restricted articles from quarantined counties is regulated by the California Department of Food and Agriculture (CCR3700). Fifteen California counties including Alameda, Contra Costa, Humboldt, Lake, Marin, Mendocino, Monterey, Napa, San Francisco, Santa Clara, Santa Cruz, San Mateo, Solano, Sonoma and Trinity Counties, and a portion of Curry County, Oregon are included in the quarantine. Regulated articles include nursery stock and soil and may only be moved interstate from a quarantined area if accompanied by a certificate. Restricted articles include bark chips, firewood, forest stock, or mulch from certain vegetation. Restricted articles may only be moved interstate from a quarantined area by the U.S. Department of Agriculture for experimental or scientific purposes.

## 3.0 METHODS

On January 23, 2017, the Study Area was traversed on foot to 1) survey and mark trees, and 2) conduct a routine wetland delineation as addenda to work performed on the adjacent parcels (see Figure 1).

### 3.1 Biological Communities

Prior to the site visit, the Soil Survey of Alameda County, California (USDA 1981), aerial imagery, and previous reports from the adjacent Oak Knoll Project Area were examined to determine if any unique soil types that could support sensitive plant communities and/or aquatic features were present in the Study Area. Biological communities present in the Study Area were classified based on existing plant community descriptions described in the *Preliminary Descriptions of the Terrestrial Natural Communities of California* (Holland 1986) and *A Manual of California Vegetation, Online Edition* (CNPS 2015a). Holland classifies more often in broader, habitat-level descriptions than those in *A Manual of California Vegetation, Online Edition*, which typically provides narrower classifications based on individual species or small groups of species. Although the CDFW uses Natural Community descriptions used in *A Manual of California Vegetation, Online Edition*, it also follows habitat descriptions used by Holland, such as freshwater marsh. In some cases, it is necessary to identify variants of community types or to describe non-vegetated areas that are not described in the literature. Biological communities were classified as sensitive or non-sensitive as defined by CEQA and other applicable laws and regulations.

#### 3.1.1 Non-sensitive Biological Communities

Non-sensitive biological communities are those communities that are not afforded special protection under CEQA, and other state, federal, and local laws, regulations and ordinances. These communities may, however, provide suitable habitat for some special-status plant or wildlife species and are identified or described in Section 4.1.1.

#### 3.1.2 Sensitive Biological Communities

Sensitive biological communities are defined as those communities that are given special protection under CEQA and other applicable federal, state, and local laws, regulations and ordinances. Applicable laws and ordinances are discussed above in Section 2.0. Special methods used to identify sensitive biological communities are discussed below.

### Wetlands and Waters

On January 23, 2017, WRA conducted a routine wetland delineation in the Study Area to determine the presence of potential wetlands and non-wetland waters subject to federal jurisdiction under Section 404 of the Clean Water Act (WRA 2017).

The majority of Former Naval Medical Center Parcel was previously surveyed for wetlands and waters potentially subject to jurisdiction by the Corps, RWQCB, or CDFW in 2006 (WRA 2007; Corps File Number 2006-400240S). The wetland delineation was conducted using the three-parameter approach as defined in the Corps Manual (Environmental Laboratory 1987). The delineation was verified by the Corps in 2007 and was later re-verified on May 16, 2013. The current verification is valid for five years from the date of issuance. In addition, the Hardenstine parcel was delineated in February 2015 (WRA 2015b). A site visit with the Corps, RWQCB, and CDFW was conducted in July 2015 and verification is currently pending.

## Other Sensitive Biological Communities

The Study Area was evaluated for the presence of other sensitive biological communities, including riparian areas, and sensitive plant communities recognized by CDFW. Prior to the site visit, aerial photographs, local soil maps, and *A Manual of California Vegetation* (CNPS 2015b) were reviewed to assess the potential for sensitive biological communities to occur in the Study Area. As discussed above in Section 2.1, all vegetation alliances within the Study Area with a CDFW ranking of 1 through 3 were considered sensitive biological communities and mapped. These communities are described in Section 4.1.2.

### **3.2 Special-Status Species**

#### *3.2.1 Literature Review*

Potential occurrence of special-status species in the Study Area was evaluated by first determining which special-status species occur in the vicinity of the Study Area through a literature and database search. Database searches for known occurrences of special-status species focused on the Oakland East 7.5-minute United States Geologic Survey quadrangle (USGS 2015) as well as the eight surrounding quadrangles. In addition, the USFWS species list for the county of Alameda was researched for other potential species occurrences. The following resources were reviewed to determine which special-status plant and wildlife species have been documented to occur in the vicinity of the Study Area:

- CNDDDB records (CDFW 2015)
- USFWS Information for Conservation and Planning Database (USFWS 2015)
- CNPS Inventory records (CNPS 2015a)
- Consortium of California Herbaria (CCH 2015)
- CDFG publication “California’s Wildlife, Volumes I-III” (Zeiner et al. 1990)
- CDFG publication “California Bird Species of Special Concern” (Shuford and Gardali 2008)
- CDFG publication “Amphibians and Reptile Species of Special Concern in California” (Jennings 1994)
- A Field Guide to Western Reptiles and Amphibians (Stebbins 2003)
- Fairy Shrimps of California’s Puddles, Pools and Playas (Eriksen and Belk 1999)
- University of California at Davis Information Center for the Environment Distribution Maps for Fishes in California (ICE 2015)
- Alameda County Breeding Bird Atlas (Richmond et al. 2011)

#### *3.2.2 Site Assessment*

During the January 23, 2017 site visit, habitat conditions were observed in the Study Area, and were used to evaluate the potential for presence of special-status species based on the search and the professional expertise of the investigating biologists. The potential for each special-status species to occur in the Study Area was then evaluated according to the following criteria:

- No Potential. Habitat on and adjacent to the site is clearly unsuitable for the species requirements (foraging, breeding, cover, substrate, elevation, hydrology, plant community, site history, disturbance regime).



- Unlikely. Few of the habitat components meeting the species requirements are present, and/or the majority of habitat on and adjacent to the site is unsuitable or of very poor quality. The species is not likely to be found on the site.
- Moderate Potential. Some of the habitat components meeting the species requirements are present, and/or only some of the habitat on or adjacent to the site is unsuitable. The species has a moderate probability of being found on the site.
- High Potential. All of the habitat components meeting the species requirements are present and/or most of the habitat on or adjacent to the site is highly suitable. The species has a high probability of being found on the site.
- Present. Species is observed on the site or has been recorded (i.e. CNDDDB, other reports) on the site recently.

The site assessment is intended to identify the presence or absence of suitable habitat for each special-status species known to occur in the vicinity to determine its potential to occur in the Study Area. The site visit does not constitute a protocol-level survey and is not intended to determine the actual presence or absence of a species. However, a separate protocol-level rare plant survey was conducted by WRA on the adjacent Former Naval Medical Center Parcel, and the findings of that survey (WRA 2015c) are incorporated into the original BRA (WRA 2015a).

In cases where little information is known about species occurrences and habitat requirements, the species evaluation was based on best professional judgment of WRA biologists with experience working with the species and habitats. If necessary, recognized experts in individual species biology were contacted to obtain the most up to date information regarding species biology and ecology.

## 4.0 RESULTS

The Study Area is located in the southeast portion of the Oakland East USGS 7.5-minute Quadrangle map (USGS 2015), approximately seven miles southeast of downtown Oakland, and is bounded by Keller Avenue to the north and west, and the Former Naval Medical Center Parcel to the south and east. In general, topography in the Study Area is downsloping toward the southwest from Keller Avenue towards the Former Naval Medical Center Parcel. Elevations range from approximately 345 feet on the eastern edge to 400 feet in the southwestern corner. The Keller Avenue and EBMUD parcels serve as right-of-way between Keller Avenue and the adjacent infrastructure development associated with the former naval base and medical center. The Keller Avenue parcel is divided by Williams Street, which historically provided access to the adjacent parcel. The majority of the Study Area is characterized by disturbed or planted vegetation types including non-native annual grassland, developed/ruderal vegetation, coast live oak (*Quercus agrifolia*) woodland, and remnant riparian trees, including buckeye (*Aesculus californica*) and arroyo willow (*Salix lasiolepis*). Rifle Range Creek, a tributary of Arroyo Viejo, flows from north to south for approximately 22 feet across the center of the Study Area, and is bordered by riparian woodland. Surrounding land uses are primarily residential development, small local commercial centers, and regional open space.

### 4.1 Biological Communities

Table 3 summarizes the area of each biological community type observed in the Study Area. There are three non-sensitive biological communities in the Study Area. Three sensitive biological communities are found in the Study Area: oak woodland, riparian woodland, and perennial/intermittent stream. Descriptions for each biological community are contained in the following sections. Biological communities within the Study Area are shown in Figure 2.

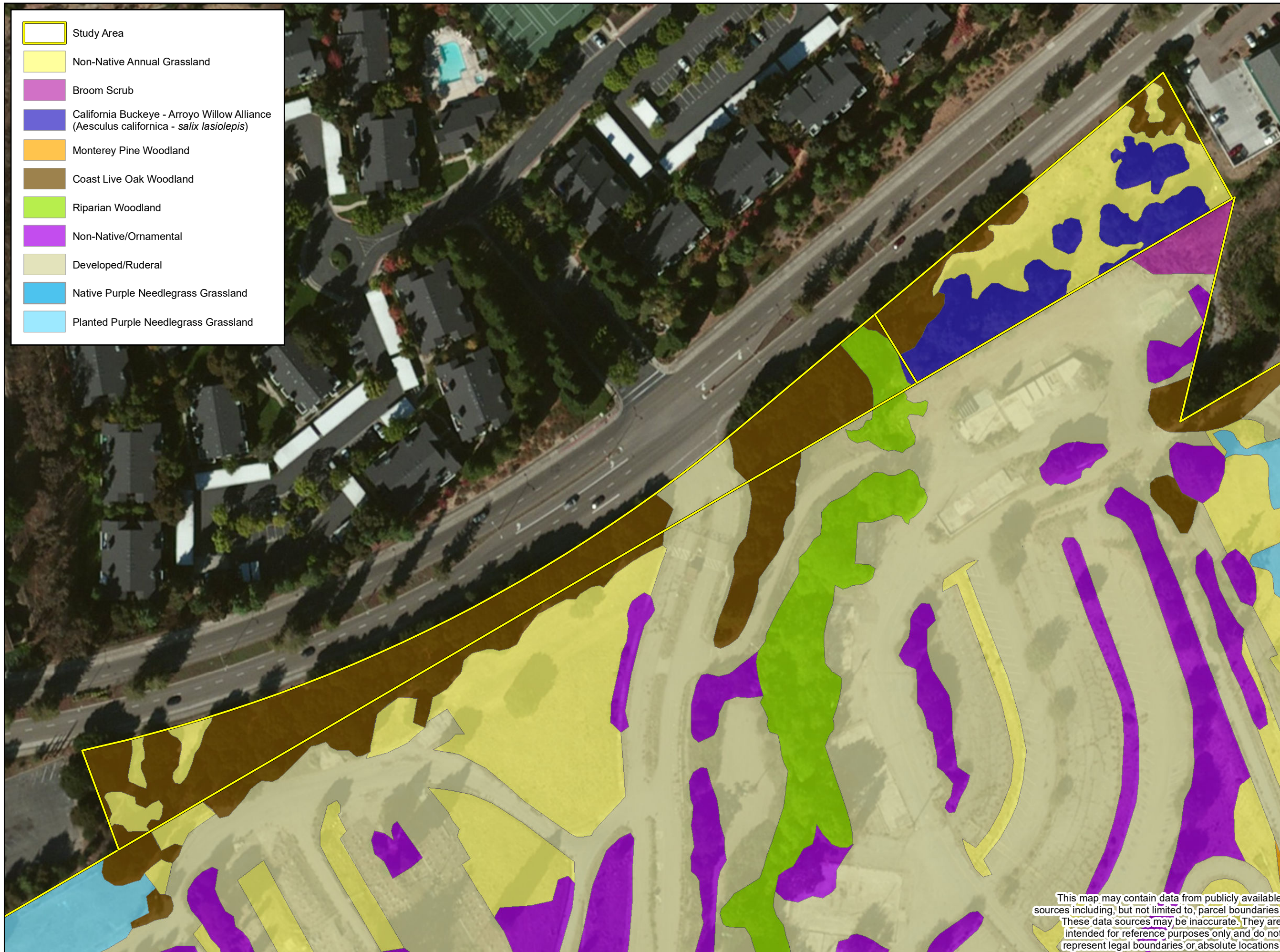
Table 3. Summary of Biological Communities in the Study Area

Community Type	Area within the Study Area (acres)
<b>Non-sensitive biological communities</b>	
Developed/ruderal	0.10
Non-native annual grassland	0.58
California Buckeye-Arroyo Willow	0.44
<b>Sensitive biological communities</b>	
Coast live oak woodland	1.20
Perennial/intermittent stream	22 linear feet
Riparian woodland	0.10
<b>Total</b>	<b>2.42</b>

Oak Knoll Mixed Use  
Community  
Development Project

Alameda County,  
California

Figure 2.  
Biological Communities



This map may contain data from publicly available sources including, but not limited to, parcel boundaries. These data sources may be inaccurate. They are intended for reference purposes only and do not represent legal boundaries or absolute locations.

Map Prepared Date: 1/27/2017  
Map Prepared By: czumwalt  
Base Source: USDA NAIP 2014  
Data Source(s): WRA

#### 4.1.1 Non-Sensitive Biological Communities

##### Non-native Annual Grassland

Non-native annual grassland typically occurs in open areas of valleys and foothills throughout California, usually on fine textured clay or loam soils that are somewhat poorly drained (Holland 1986), though it can occur on a variety of substrates. Within the Study Area, there are approximately 0.58 acres of non-native annual grassland. Elements of two different vegetation alliances/associations, as described by *A Manual of California Vegetation, Online Edition* (CNPS 2015b) occur in non-native grassland in the Study Area, but they are typically too small and/or too intermixed to map separately. These alliances/associations include *Avena (barbata, fatua)* Semi-Natural Herbaceous Stands (wild oats grasslands) and *Bromus (diandrus, hordeaceus)—Brachypodium distachyon* Semi-Natural Herbaceous Stands (annual brome grasslands). Non-native annual grassland occurs throughout the Study Area and is typically dominated by non-native annual grasses and forbs along with scattered native species, including slender oat (*Avena barbata*), ripgut brome (*Bromus diandrus*), rattail fescue (*Festuca myuros*), English plantain (*Plantago lanceolata*), and longbeak stork's bill (*Erodium botrys*).

##### Developed/Ruderal

Although not described in the literature, developed/ruderal habitats include areas that have been heavily altered by humans and may contain built structures, landscaping, gravel roads, paved areas, or other non-natural surfaces. A total of 0.10 acres of developed/ruderal habitat is present throughout the Study Area. These areas are generally unvegetated, but may support sparse, primarily non-native vegetation including French broom (*Genista monspessulana*), ripgut brome, soft chess (*Bromus hordeaceus*), and yellow annual sweetclover (*Melilotus indicus*).

##### Remnant Riparian Stand

An approximately 0.44-acre stand of California buckeye and arroyo willow occur east of the riparian corridor, downstream of a small wetland swale (WRA 2017). Trees within this area are generally mature and the area appears not to be supported by active wetland hydrology, as new saplings and typical riparian understory species are absent.

#### 4.1.2 Sensitive Biological Communities

##### Riparian Woodland

Riparian woodland occurs on and adjacent to the banks of Rifle Range Creek. This community contains elements of the communities described as Central coast live oak riparian forest (Holland 1986) and Coast live oak woodland (*Quercus agrifolia* Woodland Alliance; Rarity ranking G5, S4; CNPS 2015b). The overstory is generally dense, composed primarily of coast live oak, and the understory is generally open. Common understory shrub species include poison oak and California blackberry (*Rubus ursinus*). This community is regulated by the CDFW under the CFGC (Section 1600 et seq.).

##### Coast Live Oak Woodland

Coast live oak woodland is known from the outer and inner Coast Ranges, Transverse Ranges, and southern coast from northern Mendocino County south to San Diego County. This vegetation community is typically located on terraces, canyon bottoms, slopes, and flats underlain by deep, well-drained sandy or loam substrates with high organic content (CNPS 2015b). Coast live oak

woodland is approximately 1.20 acres of the Study Area. The overstory is composed of dense coast live oak with occasional holly oak (*Q. ilex*). The understory is relatively open. Common understory shrub species include poison oak and California blackberry. Coast live oak woodland has a sensitivity ranking of G5 S4, indicating that it is globally secure and apparently secure in California; however, coast live oak trees are protected per the City of Oakland Tree Protection Ordinance. Additionally, coast live oak is listed as locally rare (A2) by the East Bay CNPS Chapter. Although it is a common species in Alameda and Contra Costa counties, coast live oak was included on the locally rare list because “many trees [are] being attacked by Sudden Oak Death” (Lake 2010).

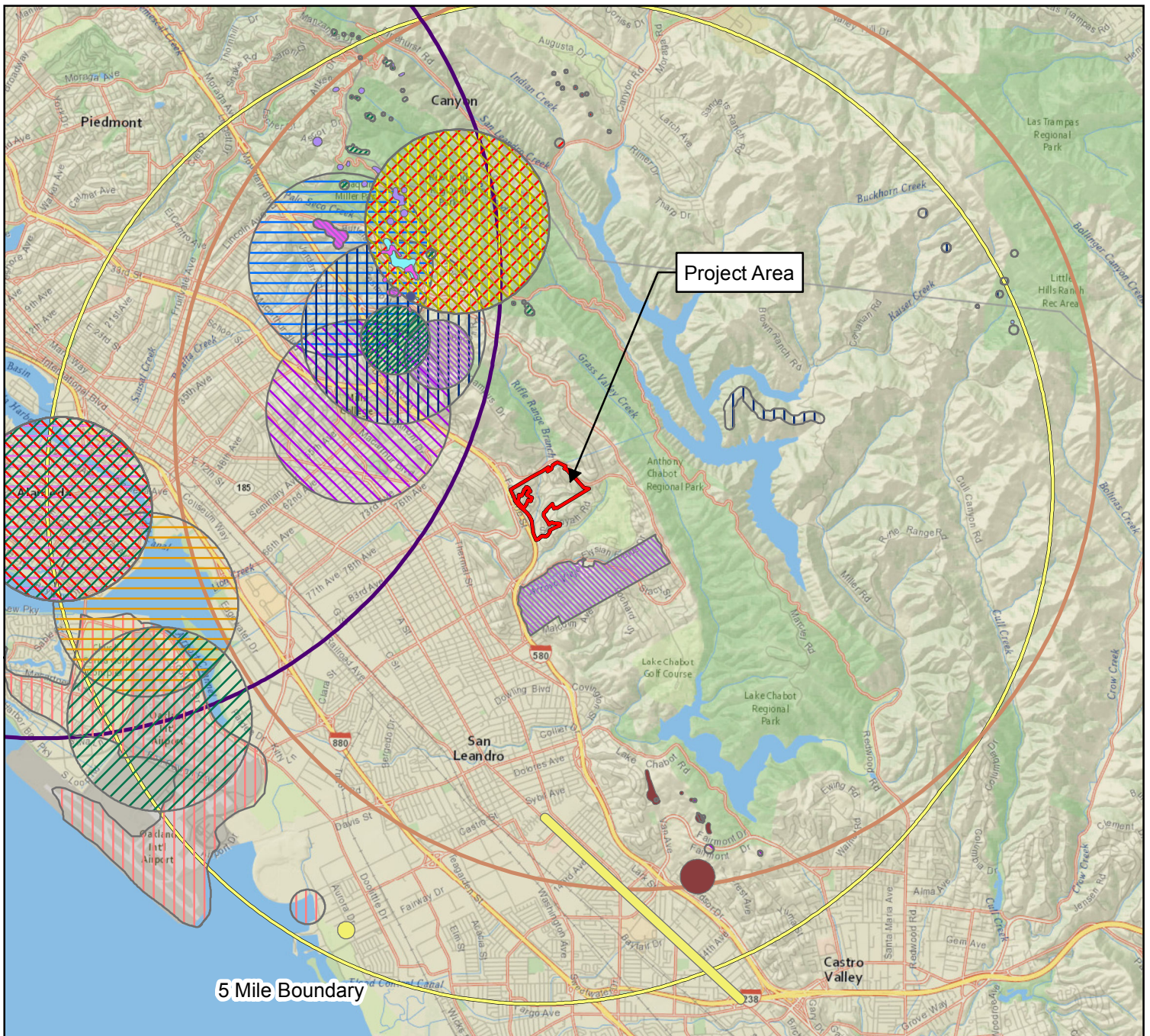
#### Perennial/Intermittent Stream

The Study Area contains approximately 22 linear feet of Rifle Range Creek, a perennial stream. The stream enters the site through a storm drain outfall and flows south into the Former Naval Medical Center Parcel.

### **4.2 Special-Status Species**

#### *4.2.1 Plants*

Based upon a previous review of the resources and databases given in Section 3.2.1, 51 statewide special-status plant species have been documented in the vicinity of the Study Area. The majority of the Study Area is comprised of disturbed or planted vegetation types, and has been impacted by disturbance from surrounding infrastructure (e.g. roads) and development activities. As such, the special-status species documented in the vicinity were determined to be absent from the Study Area due to the absence of suitable microhabitats and disturbance within the majority of the Study Area. Appendix B summarizes the potential for occurrence for each statewide special-status plant species occurring in the vicinity of the Study Area. Statewide special-status plant species documented within five miles of the Former Naval Medical Center Parcel in the CNDDDB are shown in Figure 3.



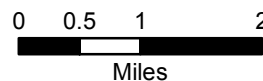
**CNDDB Plants**

- |  |                     |  |                               |  |                            |  |                        |
|--|---------------------|--|-------------------------------|--|----------------------------|--|------------------------|
|  | California seablite |  | Mt. Diablo fairy-lantern      |  | adobe sanicle              |  | pallid manzanita       |
|  | Congdon's tarplant  |  | Point Reyes salty bird's-beak |  | alkali milk-vetch          |  | robust spineflower     |
|  | Diablo helianthella |  | Presidio clarkia              |  | bent-flowered fiddleneck   |  | round-leaved filaree   |
|  | Kellogg's horkelia  |  | San Francisco popcornflower   |  | big-scale balsamroot       |  | saline clover          |
|  | Loma Prieta hoita   |  | Santa Clara red ribbons       |  | fragrant fritillary        |  | western leatherwood    |
|  | Marin knotweed      |  | Tiburon buckwheat             |  | most beautiful jewelflower |  | woodland woollythreads |

Figure 3. Special Status Plant Species within 5 miles of the Project Area



Oak Knoll Mixed Use Community Development  
Alameda County, California



Map Prepared Date: 7/22/2015  
Map Prepared By: Fhourigan  
Base Source: National Geographic  
Data Source(s): CNDDDB (December 2014)

#### 4.2.2 Wildlife

Based upon a previous review of the resources and databases (WRA 2015a), 67 special-status wildlife species have been documented in the vicinity of the Study Area. Appendix B summarizes the potential for each of these species to occur in the Study Area. Special-status wildlife species which have been documented within five miles of the Former Naval Medical Center Parcel are shown in Figure 4.

No special-status wildlife species were observed in the Study Area during the January 2017 site visit. Six special-status wildlife species have a moderate or high potential to occur in the Study Area: Nuttall's woodpecker (*Picoides nuttallii*), oak titmouse (*Baeolophus inornatus*), San Francisco dusky-footed woodrat (*Neotoma fuscipes annectens*), yellow warbler (*Setophaga petechia*), olive-sided flycatcher (*Contopus cooperi*), and Allen's hummingbird (*Selasphorus sasin*). These species are discussed in greater detail later in this section.

The remaining 61 special-status wildlife species found in the review of background literature were determined to have no potential, or to be unlikely to occur within the Study Area due to the absence of suitable microhabitats, or to the fact they have been regarded as extirpated from Alameda County, or the most recent occurrences are historic.



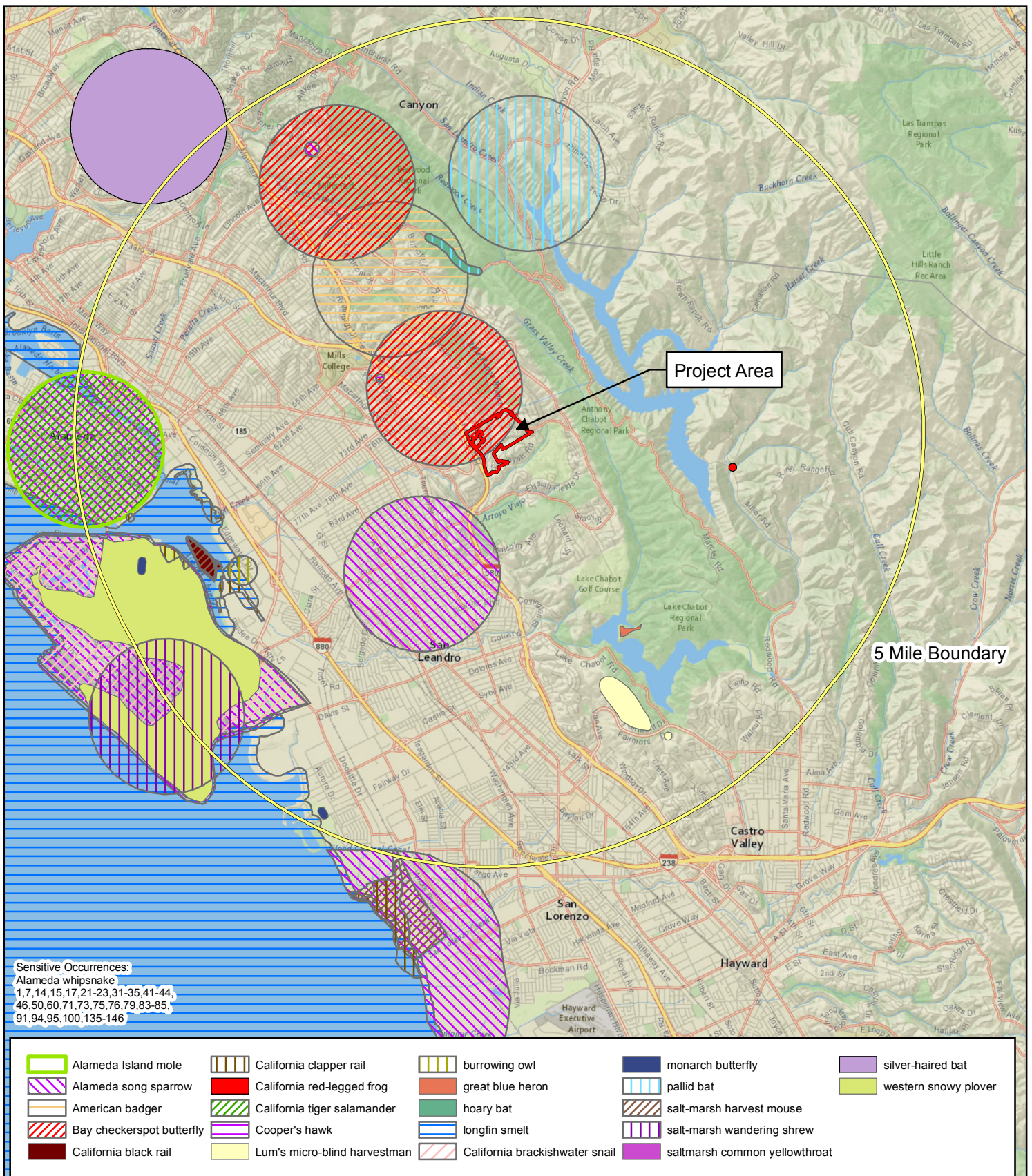
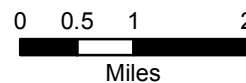


Figure 4. Special Status Wildlife Species within 5 miles of the Project Area



Oak Knoll Mixed Use Community Development  
 Alameda County, California



Map Prepared Date: 7/22/2015  
 Map Prepared By: Fhourigan  
 Base Source: National Geographic  
 Data Source(s): CNDDDB (December 2014)

## Special-Status Wildlife Species with Potential to Occur in the Study Area

**San Francisco dusky-footed woodrat (*Neotoma fuscipes annectens*), CDFW Species of Special Concern. High Potential.** This subspecies of the dusky-footed woodrat occurs in the Coast Ranges between San Francisco Bay and the Salinas River (Matocq 2003). Occupied habitats are variable and include forest, woodland, riparian areas, and chaparral. Woodrats feed on woody plants, but will also consume fungi, grasses, flowers and acorns. Foraging occurs on the ground and in bushes and trees. This species constructs robust stick houses/structures in areas with moderate cover and a well-developed understory containing woody debris. Breeding takes place from December to September. Individuals are active year-round, and generally nocturnal. Fragments of wooded habitat may provide sufficient habitat complexity and diversity to support the species. In addition, during tree surveys in the spring of 2015, middens or houses constructed by woodrats were observed within the Former Naval Medical Center Parcel.

**Yellow warbler (*Setophaga petechia*), CDFW Species of Special Concern, USFWS Bird of Conservation Concern. Moderate Potential.** The yellow warbler is a neotropical migrant bird that is widespread in North America, but has declined throughout much of its California breeding range. The Brewster's (*brewsteri*) subspecies is a summer resident and represents the vast majority of yellow warblers that breed in California. West of the Central Valley, typical yellow warbler breeding habitat consists of dense riparian vegetation along watercourses, including wet meadows, with willow growth especially being favored (Shuford and Gardali 2008). Insects comprise the majority of the diet. Riparian vegetation along Rifle Branch Creek may be of sufficient density to support nesting by the species.

**Olive-sided Flycatcher (*Contopus cooperi*), CDFW Species of Special Concern, USFWS Bird of Conservation Concern. Moderate Potential.** The olive-sided flycatcher is a summer resident in California, wintering in Central and South America. It breeds in a variety of forested habitats, typically coniferous forests at higher elevations, but also in mixed forest and woodlands at lower elevations. Breeding habitat is often associated with forest openings and edges, both natural (e.g., meadows, canyons) and man-made (e.g., logged areas) (Altman and Sallabanks 2012). Nests are usually in conifers, and placed at variable height on the outer portions of branches. This species usually forages for insects from prominent tree snags. The Study Area contains habitat mosaics between patches of wooded habitat and open ground which may support nesting and foraging by the species. In addition, local accounts of this species have been recorded within 0.25 miles of the Study Area (eBird 2015).

**Oak titmouse (*Baeolophus inornatus*), USFWS Bird of Conservation Concern. High Potential.** This species is relatively common within oak woodlands, and is a year-round resident throughout much of California including most of the coastal slope, the Central Valley and the western Sierra Nevada foothills. Its primary habitat is woodland dominated by oaks and is listed as a bird of conservation concern due to the decline of suitable oak woodland habitat. Local populations have adapted to woodlands of pines and/or junipers in some areas. The oak titmouse nests in tree cavities, usually natural cavities or those excavated by woodpeckers, though they may partially excavate their own (Cicero 2000). Seeds and arboreal invertebrates make up the birds' diet. Trees within the Study Area are of sufficient age and complex structure to support small cavities which may be used by the species for nesting. During the May 22, 2015 site visit, the species was observed foraging within the adjacent Former Naval Medical Center Parcel.

**Nuttall's woodpecker (*Picoides nuttallii*). USFWS Bird of Conservation Concern. High Potential.** Nuttall's Woodpecker, common in much of its range, is a year-round resident throughout most of California west of the Sierra Nevada. Typical habitat is oak or mixed

woodland, and riparian areas (Lowther 2000). Nesting occurs in tree cavities, principally those of oaks and larger riparian trees. This species forages on a variety of arboreal invertebrates. Trees within the Study Area are of sufficient age and complex structure to support small cavities which may be used for nesting by the species. During the May 22, 2015 site visit, the species was observed foraging within the adjacent Former Naval Medical Center Parcel.

**Allen's hummingbird (*Selasphorus sasin*). USFWS Bird of Conservation Concern. High Potential.** Allen's hummingbird, common in many portions of its range, is a summer resident along the majority of California's coast and a year-round resident in portions of coastal southern California and the Channel Islands. Breeding occurs in association with the coastal fog belt, and typical habitats used include coastal scrub, riparian, woodland and forest edges, and eucalyptus and cypress groves (Mitchell 2000). It feeds on nectar, as well as insects and spiders. This species is a common resident within this portion of its range. Trees and wooded habitat within the Study Area are of sufficient density and diversity to support nesting by the species. This species has been observed and recorded within 0.25 miles of the Former Naval Medical Center Parcel (eBird 2015).

#### Federally Listed Wildlife Species Considered Unlikely to Occur in the Study Area

Federally listed species that are documented within the vicinity of the Study Area, but are unlikely to occur include: Alameda whipsnake and California red-legged frog (*Rana draytonii*). These species are discussed below.

**Alameda Whipsnake (*Masticophis lateralis euryxanthus*). Federal Threatened Species, State Threatened Species.** Alameda Whipsnake was listed as California State Threatened on June 6, 1971, Federal Threatened December 5, 1997 (62 FR 64306-64320), and critical habitat was designated October 2, 2006 (71 FR 58176-58231). The range of the Alameda whipsnake is restricted to the inner Coast Range in western and central Contra Costa and Alameda Counties (USFWS 2012). The historical range of AWS has been fragmented into five disjunct populations: Tilden-Briones, Oakland-Las Trampas, Hayward-Pleasanton Ridge, Sunol-Cedar Mountain, and the Mount Diablo-Black Hills (USFWS 2012). The AWS is associated with scrub communities, including mixed chaparral, chamise-redshank chaparral, coastal scrub, and annual grassland and oak woodlands that lie adjacent to scrub habitats that contain areas of rock outcroppings. Rock outcroppings are important as they are a favored location for lizard prey. Whipsnakes frequently venture into adjacent habitats, including grassland, oak savanna, and occasionally oak-bay woodland.

Alameda whipsnake is unlikely to be present within the Study Area because of a lack of habitat connectivity, extremely limited suitable habitat, and no detections during three prior surveys of the Former Naval Medical Center Parcel (Swaim 1996, Swaim 2006, Alvarez 2015).

**California Red-legged Frog (*Rana draytonii*). Federal Threatened Species. CDFW Species of Special Concern.** The California red-legged frog (CRLF) was listed as Federally Threatened on May 23, 1996 (61 FR 25813-25833). Critical Habitat for the CRLF was designated on April 13, 2006 (71 FR 19243-19346), and the revised designation was finalized on March 17, 2010 (75 FR 12815-12959). A Recovery Plan for the CRLF was published by the USFWS on May 28, 2002.

There are four primary habitat types which are used by CRLF throughout their life cycles. The primary habitat types include: aquatic breeding habitat; non-breeding aquatic habitat; upland habitat; and dispersal habitat (USFWS 2010).

Aquatic breeding habitat consists of low-gradient fresh water bodies, including natural and manmade (e.g., stock) ponds, backwaters within streams and creeks, marshes, lagoons, and dune ponds. Aquatic non-breeding habitat may or may not hold water long enough for this species to hatch and complete its aquatic life cycle, but it provides shelter, foraging, predator avoidance, and aquatic dispersal for juvenile and adult CRLF. Non-breeding aquatic features enable CRLF to survive drought periods, and disperse to other aquatic breeding habitat (USFWS 2010). Upland habitats include areas within 300 feet of aquatic and riparian habitat and are comprised of grasslands, woodlands, and/or vegetation that provide shelter, forage, and predator avoidance. Upland habitat can include structural features such as boulders, rocks and organic debris (e.g. downed trees, logs), as well as small mammal burrows and moist leaf litter (USFWS 2010). Dispersal Habitat includes accessible upland or riparian habitats between occupied locations within 0.7 mile of each other that allow for movement between these sites. Dispersal habitat includes various natural and altered habitats such as agricultural fields, which do not contain barriers to dispersal. Moderate to high-density urban or industrial developments, large reservoirs and heavily traveled roads without bridges or culverts are considered barriers to dispersal (USFWS 2006).

California red-legged frog is unlikely to be found within the Study Area because of a lack of connectivity to populations outside of the Study Area, the absence of suitable upland and dispersal habitat within the Study Area, and historical development within the Study Area.

The Study Area is surrounded by urban development, and Keller Avenue, a heavily traveled four-lane road separates the Study Area from the undeveloped habitat to the north and is considered a significant barrier to amphibian dispersal (USFWS 2001). The dispersal barriers isolate the Study Area, and make it unlikely for CRLF to successfully disperse into the Study Area.

The nearest occurrence of this species was recorded in 2008 and is located east of Upper San Leandro Reservoir, approximately three miles from the Former Naval Medical Center Parcel. Located between the nearest occurrence and the Study Area is a solid band of urban development extending for approximately 0.75 mile. The high level of development surrounding the Study Area and separating it from nearby occurrences, combined with the lack of habitat connectivity mentioned above, makes the Study Area inaccessible to source populations of CRLF.

Based on the lack of habitat connectivity to occupied habitat, a lack of upland habitat with suitable structure to support estivation as well as a lack of dispersal habitat, and development impacts within the Study Area, we conclude CRLF are unlikely to be present in the Study Area. This conclusion concurs with findings for the project EIR (Naval Facilities Engineering Command and City of Oakland 1998) and the findings by the Department of the Navy (1998) which both concurred that CRLF was not present.

### **Foothill yellow-legged frog (*Rana boylei*), USFWS species of special concern, CDFW species of special concern**

Foothill yellow-legged frogs require shallow streams and rivers with sunny banks and large boulders for basking, and prefer some cobble sized substrate (Jennings and Hayes, 1994). They are found in forest, chaparral, and woodland habitats. Riffle habitat is important.

According to the EIR (Naval Facilities Engineering Command and City of Oakland 1998), foothill yellow-legged frogs could exist in the riparian areas of the Former Naval Medical Center Parcel. However, the portion of Rifle Range Creek within the Study Area is limited to 22 linear feet that is mainly a stormwater outfall, and has substantial channel alteration. Basking habitat such as

sunny banks and large boulders were absent within the Study Area, and impacts to creek habitat downstream of the Study Area prevent dispersal through the creek corridor, making it unlikely that the species could disperse between creek habitat patches. Based on these findings, the species is unlikely to be present in the Study Area.

## 5.0 POTENTIAL IMPACTS, AVOIDANCE, MINIMIZATION, AND MITIGATION MEASURES

### 5.1 Project Description

#### Overall Project Description

Development within the Study Area would involve grading for construction of a ball field and open space area associated with the Former Naval Medical Center Parcel, as well as development of a trail system that would link open space areas throughout the Project Area. Oak Knoll is a Master Planned Residential Community Development Project ("Project") that would develop up to 935 residential units, including a range of single-family housing types and townhomes that would be developed throughout the Project Area (Figure 5). A Village Center would provide approximately 72,000 square feet of locally serving commercial uses. The Project would also create approximately 75 to 85 acres of publicly accessible open space comprising an extensive network of parks, trails, and walkways that would weave through the Project Area, connecting various neighborhoods within the Project Area with adjacent open space areas and neighborhoods. Additionally, the Project includes restoration of the majority of Club Knoll, an existing structure, resulting in the Community Center, with approximately 10,000 square feet of limited commercial uses and approximately 4,000 square feet for community/HOA uses.

Two portions of the Project would involve impacts to jurisdictional waters: the proposed restoration and enhancement of Rifle Range Creek, and the filling of the small (0.04 acre) wetland in the northeastern corner of the Study Area. These components of the Project are discussed in greater detail below.

#### Proposed Restoration Activities

Rifle Range Creek flows south from a stormwater outfall into the Study Area for approximately 22 feet, then continues into the Project Site. The creek and associated riparian corridor within the Study Area will be included in the restoration activities slated for the remaining six reaches of Rifle Range Creek and the two associated tributaries, Powerhouse Creek and Hospital Creek located in the Former Naval Medical Center Parcel (Figure 6). Within Rifle Range Creek, active erosion is evident in the creek channel and along both banks. Please refer to the original BRA (WRA 2015a) and Riparian Restoration and Monitoring Plan (WRA 2015d) for additional details.

Earthwork and grading activities are proposed to reduce bank slopes, reduce the channel gradient, and stabilize the creek banks. Clean fill would be placed within the OHWM of the creek to re-align and stabilize the channel and to reduce the channel gradient. Fill material would consist of clean cobbles and gravels as well as logs and boulders for grade control. Additional fill would be required above the OHWM to create the floodplain terraces and stabilize creek banks.

Grading would be required to reduce channel slopes and to establish suitable conditions for the installation of stabilization structures and plantings. Grading activities would include re-profiling the creek banks, and roughening the channel to stabilize major knick points and provide continuity of the channel gradient. The newly restored channel would typically consist of a 12-foot-wide low flow channel, a floodplain terrace up to 40-feet-wide, and channel banks at between 1.5:1 and 3:1 slopes. Appropriate native vegetation would be selected based on slope characteristics and proximity to the creek.

The wetland located within the Study Area appears to have significantly altered hydrology from adjacent development and past on-site disturbances. Water mapped during the wetland delineation (WRA 2017) supports sparse hydrophytic vegetation and an overstory of remnant

riparian trees with no emerging seedlings or samplings. As part of the development of open space and park facilities associated with the Former Naval Medical Center Parcel, this portion of the Study Area will be graded and filled to accommodate a ball field and other recreational facilities.

Oak Knoll Mixed Use Community Development  
Alameda County, California

Figure 5.  
Overall Site Plan



*Not to Scale*

Map Prepared Date: 1/31/2017  
Map Prepared By: czumwalt  
Base Source:  
Data Source(s):



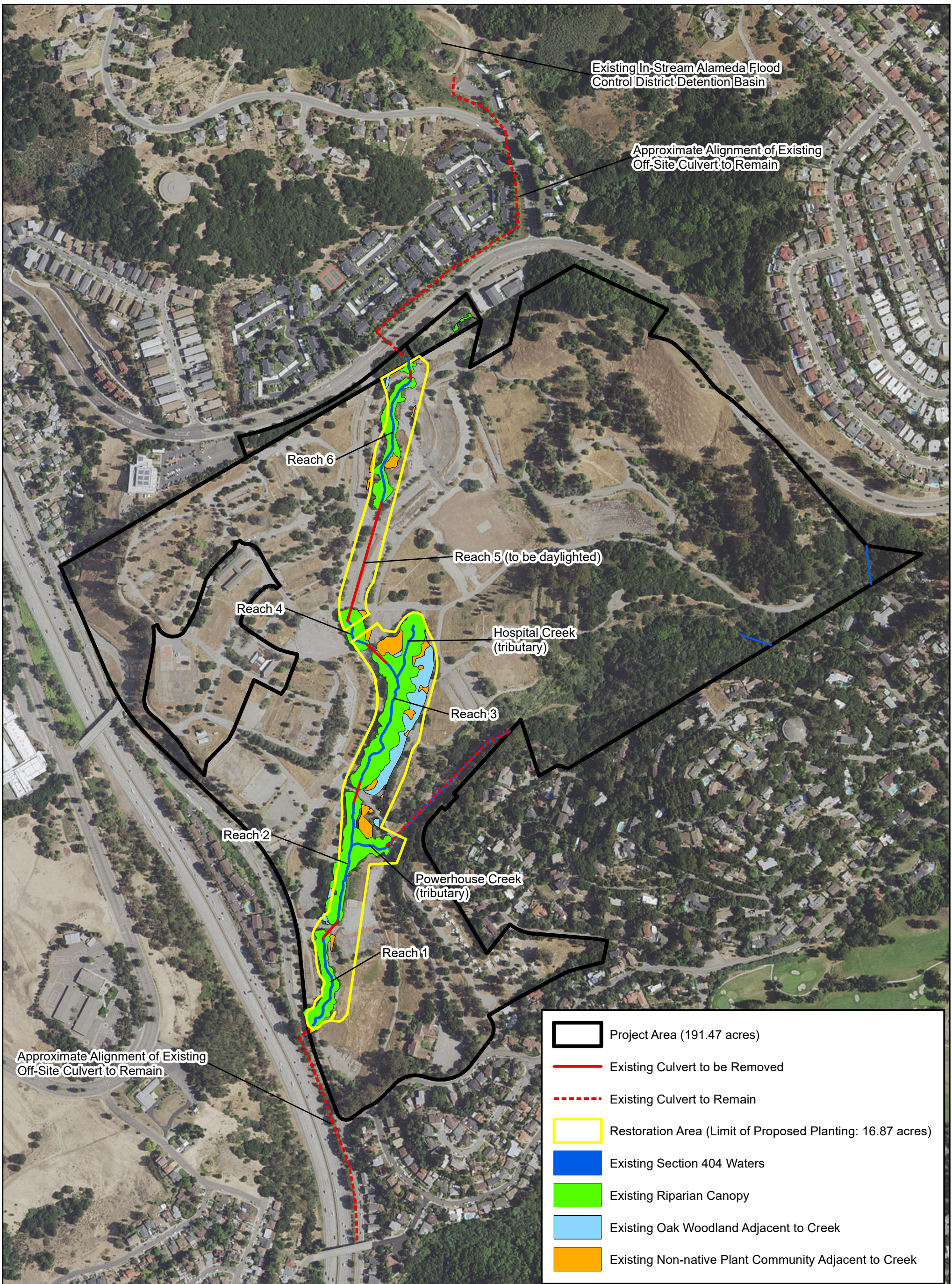
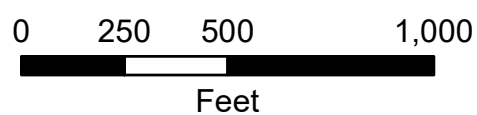


Figure 6. Creek and Riparian Overview Map

Oak Knoll Development  
Alameda County, California

Oak Knoll Venture Acquisition LLC  
2392 Morse Avenue  
Irvine, CA 92614  
Contact: Mike Turner  
mturner@argmentmanagementllc.com



Map Prepared Date: 1/31/2017  
Map Prepared By: czumwalt  
Base Source: USGS EROS 2013  
Data Source(s): WRA

### Timing of Construction Activities

Rifle Range Creek would be restored concurrently with infrastructure construction for the larger Oak Knoll redevelopment project. Grading of the creek banks and channel would begin at the downstream end of Reach 1 within the adjacent Oak Knoll Development Site and would proceed upstream to Reach 6 within the Study Area. Prior to grading within each reach, the perennial creek flow would be diverted into a suitably sized temporary culvert and routed around the work area such that downstream flows are maintained throughout the work period. Upon completion of grading work within a reach, flows would be returned to the newly restored channel. There is likely to be an overlap in the timing of some work efforts between adjacent creek reaches.

Extensive erosion and sediment control measures would be installed along the banks and at the downstream end of each channel reach prior to the initiation of any work on that reach. These protective measures would be maintained beyond the completion of creek and bank grading work until banks are vegetated or otherwise permanently protected from erosive forces.

Revegetation of the creek banks with native trees, shrubs, and grasses would likely take place in September and October prior to the start of the rainy season. It is likely that all six reaches of the restored Rifle Range Creek would be planted concurrently.

### **5.2 Significance Threshold Criteria**

Pursuant to Appendix G, Section IV of the State CEQA Guidelines, a project would have a significant impact on biological resources if it would:

- a) Have a substantial adverse effect, either directly or through habitat modifications, on any species identified as a candidate, sensitive, or special-status species in local or regional plans, policies, or regulations, or by the CDFW or USFWS;
- b) Have a substantial adverse effect on any riparian habitat or other sensitive natural community identified in local or regional plans, policies, regulations, or by the CDFW or USFWS;
- c) Have a substantial adverse effect on federally protected wetlands as defined by Section 404 of the Clean Water Act (including, but not limited to, marsh, vernal pool, coastal, etc.) through direct removal, filling, hydrological interruption, or other means;
- d) Interfere substantially with the movement of any native resident or migratory fish or wildlife species or with established native resident or migratory wildlife corridors, or impede the use of native wildlife nursery sites;
- e) Conflict with any local policies or ordinances protecting biological resources, such as a tree preservation policy or ordinance; and/or,
- f) Conflict with the provisions of an adopted Habitat Conservation Plan, Natural Community Conservation Plan, or other approved local, regional, or state habitat conservation plan.

This report utilizes these thresholds in the analysis of impacts and determination of the significance of those impacts. The assessment of impacts under CEQA is based on the changes caused by the Project relative to the existing conditions in the Study Area. The existing conditions in the Study Area are described above, based on the survey conducted in 2017. In applying

CEQA Appendix G, the terms “substantial” and “substantially” are used as the basis for significance determinations in many of the thresholds, but are not defined qualitatively or quantitatively in CEQA or in technical literature. In some cases, such as direct impacts to special-status species listed under the CESA or ESA, the determination of a substantial impact may be relatively straightforward. In other cases, the determination is less clear, and requires application of best professional judgment based on knowledge of site conditions as well as the ecology and physiology of biological resources present in a given area. Determinations of whether or not Project activities will result in a substantial adverse effect to biological resources are discussed in the following sections for sensitive biological communities, special-status plant species, and special-status wildlife species.

### 5.3 Potentially Significant Impacts

#### Sensitive Biological Communities

##### *Impact BIO-1: Impacts to riparian woodland (Threshold (b))*

Within the Study Area, the Project would impact approximately 0.10 acres of riparian woodland habitat due to re-grading associated with the restoration of Rifle Range Creek. Although this area will be re-planted and restored as part of the Project, there will be a temporary loss of habitat during construction and a reduction in habitat quality for the first few years following re-establishment. This habitat is regulated by CDFW under Sections 1600-1616 of the CFGC. As such, this impact would be potentially significant under CEQA (criterion B). A mitigation measure (MM BIO-1) for impacts to riparian woodland is discussed below in Section 5.4. With implementation of MM BIO-1 this impact would be less than significant.

##### *Impact BIO-2: Impacts to Waters of the United States (Threshold (c))*

The Project will temporarily impact 22 linear feet of perennial/intermittent stream habitat due to temporary dewatering and water diversion through the work area, and/or placement of fill to improve stream bank stability and a 0.04-acre wetland for development-related activities (see Table 4 below and Figure 7). These stream and wetland features are regulated by, and would require permits from, the Corps under Section 404 of the CWA, the RWQCB under section 401 of the CWA and the Porter-Cologne Water Quality Control Act, and the CDFW under Sections 1600-161 of the CFGC. The Project would also require a Creek Protection Permit from the City of Oakland.

Table 4. Impacts to Waters of the United States within the Study Area

Jurisdictional Area	Temporary Impacts <sup>1</sup>		Permanent Impacts <sup>2</sup>		
	Linear Feet	Acres	Linear Feet	Acres	Cubic Yards
Rifle Range Creek	22	0.10	n/a	n/a	n/a
Wetland in Study Area (0.04 acre)	n/a	n/a	n/a	0.04	65
<b>Total Waters of the United States</b>	<b>22</b>	<b>0.10</b>	<b>n/a</b>	<b>0.04</b>	<b>65</b>

<sup>1</sup>Temporary impacts include the following activities: (1) temporary dewatering/water diversion during construction; and (2) temporary re-grading where the channel will be returned to its existing elevation and alignment.

<sup>2</sup>Permanent impacts include the following activities: (1) fill for development-related activities

However, within the larger Former Naval Medical Center Parcel, the Project would ultimately result in a net increase in aquatic area (see Table 5 below). Additionally, potential impacts to water quality would be avoided and minimized by adhering to BMPs and permit conditions

established by the Corps, RWQCB, and CDFW. As such, this impact would be less than significant.

Table 5. Existing and Proposed Habitats in the Restoration Area

Habitat	Pre-Restoration (Existing)	Post Restoration (Proposed)
Waters of the United States (unculverted)	3,301 linear feet; 0.64 acre	4,494 Linear feet; 1.48 acres
Waters of the United States (culverted)	1,921 linear feet; 0.21 acre	922 linear feet; 0.11 acre
Total Waters	5,222 linear feet; 0.85 acre	5,213 linear feet; 1.30 acres
Riparian Habitat (including riparian edge)	8.14 acres	16.97 acres

*Impact BIO-3: Impacts to coast live oak woodland (Thresholds (a) & (b))*

Development activities in the northeastern portion of the Study Area may result in the loss of a few individual oaks, but the majority of the coast live oak woodland habitat will remain in place, as is. Coast live oak woodland receives consideration under CEQA based on its regional rarity and listing status on the East Bay CNPS Chapter’s list of “Rare, Unusual, and Significant Plants of Alameda and Contra Costa Counties (Lake 2010). This impact would be less than significant under CEQA (criteria A and B).

*Impact BIO-4: Removal of protected trees (Threshold (e))*

Within the Study Area, the Project would result in the removal of approximately 10 trees, which are protected under the City of Oakland’s Tree Protection Ordinance. The Project will obtain a tree removal permit from the City prior to the removal of these trees. As such, this impact would not conflict with local policies or ordinances (CEQA significance criterion E). Mitigation measures associated with the Ordinance are summarized below in Section 5.4 (see MM BIO-2). With implementation of MM BIO-2 this impact would be less than significant.

*Impact BIO-5: Potential Spread of Sudden Oak Death (Thresholds (a) & (b))*

Verified occurrences of SOD occur in the vicinity of the Study Area (Kelly and Tuxen 2003; Kelley et al. 2004). Although focused surveys for SOD were not conducted, the presence of the disease within the Study Area is assumed based on the proximity of the nearest verified occurrence and observations of symptoms of the disease on susceptible species within the Former Naval Medical Center Parcel. Coast live oak is one of the primary true oak (*Quercus*) species killed by SOD, and within coast live oak woodland, California bay foliage is the primary vector of the pathogen (Swiecki and Bernhardt 2013). The potential for a significant impact exists if infested plants or plant parts including mulch or firewood (particularly from California bay) are transported to a non-infested county or state, and/or proposed on-site oak woodland mitigation areas. Transportation of plants or plant material outside of the Study Area is not proposed at this time; however, some plant material will be chipped on site and used in proposed mitigation areas. With the implementation of avoidance and minimization measures included under MM BIO-3 this impact would be less than significant.

## Special-Status Wildlife Species

### *Impact BIO-6: Impacts to San Francisco dusky-footed woodrat (Thresholds (a) & (d))*

The Project has the potential to impact San Francisco dusky-footed woodrats. The Project may affect this species by killing or injuring the species during the removal of vegetation or houses used by woodrats, or by causing disturbance of a sufficient level to cause abandonment of an active nest. These impacts would be potentially significant under CEQA. A potential mitigation measure (MM BIO-5) for impacts to San Francisco dusky-footed woodrat is discussed below in Section 5.4. With implementation of MM BIO-4 this impact would be less than significant.

### *Impact BIO-7: Impacts to Special-status and Non-special-status Nesting Birds (Thresholds (a) & (d))*

The Project has the potential to impact five special-status bird species: yellow warbler, olive-sided flycatcher, oak titmouse, Nuttall's woodpecker, and Allen's hummingbird. The Project may also affect non-special-status native nesting birds which are protected by the MTBA and CFCG.

The Project may affect these species by modifying nesting habitat, or by causing disturbance of a sufficient level to cause abandonment of an active nest. Potential impacts to these species and their habitats could occur during the removal of vegetation and structures, grading, or ground-disturbing activities. These activities could result in the direct removal or destruction of the active nests of protected bird species. These activities may also create audible, vibratory and/or visual disturbances which cause birds to abandon active nests.

Activities that result in the direct removal of active nests or disturbance to breeding birds sufficient to result in the abandonment of active nests would be potentially significant under CEQA. A potential mitigation measure (MM BIO-5) for impacts to nesting birds is discussed below in Section 5.4. With implementation of MM BIO-5 this impact would be less than significant.

## 5.4 Mitigation Measures

### Sensitive Biological Communities

#### *MM BIO-1: Compensatory mitigation for impacts to riparian woodland and coast live oak woodland*

The oak woodland habitat in the Study Area, including the riparian woodland, is generally of medium to low quality due to the fragmented nature and surrounding development and roads. Therefore, riparian/oak woodland habitat shall be mitigated for at a 2:1 ratio (preserved/established area: impacted area). This ratio is consistent with guidance issued under the Oak Woodlands Conservation Act. Although the Oak Woodlands Conservation Act is only applicable in unincorporated areas under County jurisdiction and is not applicable to the Project, it provides a useful framework for evaluating significance under CEQA and determining appropriate mitigation ratios.

Potential mitigation options include the following: (1) planting replacement trees, or (2) establishing a restrictive covenant to protect existing woodland habitat. If habitat is preserved and/or established for mitigation, a Habitat Mitigation and Monitoring Plan (HMMP) shall be prepared. The HMMP will include a detailed description of restoration/enhancement/preservation actions proposed; restoration criteria for each biological parameter (i.e., native/invasive plants, wildlife use) to meet the 2:1 ratio of preserved/established area: impacted area; and proposed monitoring/maintenance plan for each biological parameter to evaluate restoration criteria success.

#### *MM BIO-2: Compensatory mitigation for tree removal*

The City of Oakland Tree Protection Ordinance requires replacement plantings to mitigate for the loss of functions provided by protected trees including shade, erosion control, groundwater replenishment, visual screening, and wildlife habitat. Replacement trees shall be planted in accordance with the following criteria from the Ordinance:

- 1) No tree replacement shall be required for the removal of nonnative species, for the removal of trees which is required for the benefit of remaining trees, or where insufficient planting area exists for a mature tree of the species being considered.
- 2) Replacement tree species shall consist of coast redwood (*Sequoia sempervirens*), coast live oak, madrone, California buckeye, or California bay.
- 3) Replacement trees shall be of twenty-four (24) inch box size, except that three fifteen (15) gallon size trees may be substituted for each twenty-four (24) inch box size tree where appropriate.
- 4) Minimum planting areas must be available on site as follows:
  - a. For coast redwood, three hundred fifteen square feet per tree;
  - b. For all other species listed in subsection (B)(2) of this section, seven hundred (700) square feet per tree.
- 5) In the event that replacement trees are required but cannot be planted due to site constraints, an in lieu fee as determined by the master fee schedule<sup>1</sup> of the city may

---

<sup>1</sup> The City of Oakland Master Fee Schedule for the 2014-2015 fiscal year currently lists the fee as \$325 per tree removed.

be substituted for required replacement plantings, with all such revenues applied toward tree planting in city parks, streets and medians.

Plantings shall be installed prior to the issuance of a certificate of occupancy, subject to seasonal constraints, and shall be maintained by the applicant until established. The Tree Reviewer may require a landscape plan showing the replacement planting and the method of irrigation. Any replacement planting which fails to become established within one year of planting shall be replanted at the applicant's expense.

#### *MM BIO-3: Prevention of the Spread of Sudden Oak Death*

If regulated or restricted plant materials are to be transported between the Study Area and a location in a non-infested county or state, the spread of the SOD pathogen will be avoided by obtaining the necessary certificates of transport pursuant to the regulations described in Section 2.4. Additional precautionary Best Management Practices (BMPs), to prevent the spread of SOD within the Study Area during project related tree removal shall be implemented including:

##### Before working:

- Provide crews with sanitations kits. (Sanitation kits should contain the following: Chlorine bleach [10/90 mixture bleach to water], or Clorox Clean-up®, scrub-brush, metal scraper, boot brush and plastic gloves).
- Ensure that work crews have thoroughly cleaned and sanitized pruning gear, trucks and chippers prior to entering the Study Area.
- Thoroughly clean and sanitize shoes, pruning gear and other equipment before working in an area with susceptible species (e.g. coast live oak woodland and riparian woodland).
- Susceptible species present within the Study Area include: coast live oak, canyon live oak, and California bay.

##### While working:

- When possible, work on *P. ramorum*-infected and susceptible species during the dry season (June - October). The pathogen is most likely to spread during periods of high rainfall especially in Spring (April and May). Working during wet conditions should be avoided.
- If working in wet conditions cannot be avoided, keep equipment on paved or dry surfaces and avoid mud.
- Work in disease-free areas before proceeding to suspected-infestation areas.
- All debris from California bay trees, the primary vector of the pathogen, shall be mulched in place or disposed of off-site in a permitted disposal facility in accordance with state and federal regulations.
- When removing California bay trees, all mulch and debris shall be segregated from other species when chipping, and all pruning gear and equipment, including chippers and trucks shall be thoroughly cleaned and sanitized before working on coast live oaks.

##### After working:

- Use all reasonable methods to clean and sanitize personal gear and crew equipment before leaving a *P. ramorum*-infested site. Scrape, brush and/or hose off accumulated soil and mud from clothing, gloves, boots and shoes. Remove mud and plant debris,

especially California bay, by blowing it out or power washing chipper trucks, chippers, buckets trucks, fertilization and soil aeration equipment, cranes, and other vehicles.

- Restrict the movement of soil and leaf litter under and all California bay trees as spores are most abundant on California bay leaves. Contaminated soil, particularly mud, and plant debris on vehicle tires, workers boots, shovels, chippers, stump grinders, trenchers, etc., may result in pathogen spread if moved to a new, un-infested site. Thoroughly clean all equipment and wash off soil, mud, and plant debris from these items before use at another site. If complete on-site sanitation is not possible, complete the work at a local power wash facility.
- Tools used in tree removal/pruning may become contaminated and should be disinfected with Lysol® spray, a 70% or greater solution of alcohol, or a Clorox® solution (1 part Chlorox® to 9 parts water or Clorox Clean-up®).

### Special-Status Wildlife Species

#### *MM BIO-4: Pre-construction survey for San Francisco dusky-footed woodrat*

For the protection of San Francisco dusky-footed woodrats: prior to vegetation removal and/or ground disturbance within the Study Area, a pre-construction survey for woodrat structures/houses shall be conducted by a qualified biologist. Any woodrat structures found during the survey shall be flagged and avoided to the fullest extent feasible. If avoidance is not possible, then structures to be impacted shall be dismantled by hand under the supervision of a qualified biologist. If woodrat young are encountered during the dismantling process, the material shall be placed back on the house, and a work exclusion buffer of at least 20 feet placed around the structure. The structure shall remain unmolested for at least two weeks in order to allow the young to mature and leave the nest of their own accord. After the avoidance period, the nest dismantling process may begin again. Nest material shall then be moved to adjacent vegetated areas that will not be disturbed.

#### *MM BIO-5: Pre-construction surveys for nesting birds and nest avoidance*

For the protection of special status bird species and bird species protected by the Migratory Bird Treaty Act and Fish and Game Codes, Project activities shall occur during the non-breeding bird season to the extent feasible (September 1 – January 31). However, if vegetation removal, grading, or initial ground-disturbing activities must occur during the breeding season (February 1 through August 31), a survey for active bird nests shall be conducted by a qualified biologist no more than 14 days prior to the start of these activities. The survey shall be conducted in a sufficient area around the work site to identify the location and status of any nests that could potentially be affected by Project activities.

If active nests of protected species are found within Project impact areas or in close proximity to affect breeding success, a work exclusion zone shall be established around each nest by a qualified biologist. Established exclusion zones shall remain in place until all young in the nest have fledged or the nest otherwise becomes inactive (e.g., due to predation). Appropriate exclusion zone sizes vary dependent upon bird species, nest location, existing visual buffers and baseline ambient sound levels, and other factors; an exclusion zone radius may be as small as 50 feet (for common, disturbance-adapted species) or as large as 250 feet or more for raptors. Exclusion zone size may also be reduced from established levels if supported with nest monitoring by a qualified biologist indicating that work activities outside the reduced radius are not adversely impacting the nest.



## 6.0 REFERENCES

- Altman, B, and R Sallabanks. 2012. Olive-sided Flycatcher (*Contopus cooperi*), The Birds of North America Online (A. Poole, Ed.). Ithaca: Cornell Lab of Ornithology; Retrieved from the Birds of North America Online: <http://bna.birds.cornell.edu/bna/species/502>
- Alvarez, J. The Wildlife Project. 2015. Recovery Project: Demographic Analysis of the Alameda Whipsnake at the Former Oak Knoll Naval Hospital, Oakland, CA.
- Baldwin, BG, DH Goldman, DJ Keil, R Patterson, TJ Rosatti, and DH Wilken (eds.). 2012. The Jepson Manual: Vascular Plants of California, second edition. University of California Press, Berkeley, CA.
- [Cal-IPC] California Invasive Plant Council. 2015. California Invasive Plant Inventory Database. California Invasive Plant Council, Berkeley, CA. Available online at: <http://www.cal-ipc.org/paf/>. Most recently accessed: July 2015.
- [CCH] Consortium of California Herbaria. 2015. Data provided by the participants of the Consortium of California Herbaria. Available online at: <http://ucjeps.berkeley.edu/consortium/>. Most recently accessed: July 2015.
- [CDFG] California Department of Fish and Game. 2010. List of Vegetation Alliances and Associations. Vegetation Classification and Mapping Program, Sacramento, CA.
- [CDFG] California Department of Fish and Game. 1994. A Field Guide to Lake and Streambed Alteration Agreements, Sections 1600-1607, California Fish and Game Code. Environmental Services Division, Sacramento, CA.
- [CDFW] California Department of Fish and Wildlife. 2015. California Natural Diversity Database (CNDDDB). Wildlife and Habitat Data Analysis Branch, Sacramento, CA.
- Cicero, C. 2000. Oak Titmouse (*Baeolophus inornatus*), The Birds of North America Online (A. Poole, Ed.). Ithaca: Cornell Lab of Ornithology; Retrieved from the Birds of North America Online: <http://bna.birds.cornell.edu/bna/species/485a>
- [CNPS] California Native Plant Society. 2015a. Inventory of Rare and Endangered Plants of California. California Native Plant Society, Sacramento, California. Available online at: <http://www.rareplants.cnps.org>. Most recently accessed: July 2015.
- [CNPS] California Native Plant Society. 2015b. A Manual of California Vegetation, Online Edition. Sacramento, California. Available online at: <http://vegetation.cnps.org/>. Most recently accessed: May 2015.
- [Corps] United States Army Corps of Engineers. 2008. Regional Supplement to the Corps of Engineers Wetland Delineation Manual: Arid West Region.
- [Corps] United States Army Corps of Engineers and the Environmental Protection Agency. 2007. U.S. Army Corps of Engineers Jurisdictional Determination Form Instructional Guidebook.
- [CSRL] California Soil Resources Lab 2015. Online Soil Survey. Online at: <http://casoilresource.lawr.ucdavis.edu/drupal/>. Most recently accessed: July 2015.

- Department of Navy. 1998. Record of Decision for the Disposal and Reuse of Naval Medical Center, Oakland, CA. Vol. 63, No. 165. August 26, 1998.
- East Bay Regional Park District. 2015. Park-Specific Wild Plant Checklists. Available online at: <http://www.ebparks.org/about/stewardship/plants/checklist>. Most recently accessed July 2015.
- eBird. 2015. eBird: An online database of bird distribution and abundance [web application]. eBird, Cornell Lab of Ornithology, Ithaca, New York. Available online at: <http://www.ebird.org>. Most recently accessed: July 2015.
- Environmental Laboratory. 1987. Corps of Engineers Wetlands Delineation Manual. Department of the Army, Waterways Experiment Station, Vicksburg, Mississippi 39180-0631.
- Erikson, CH and D Belk. 1999. Fairy Shrimps of California's Puddles, Ponds and Playas. Mad River Press, Inc., Eureka, CA.
- Google Earth. 2015. Aerial Imagery 1993-2015. Most recently accessed: July 2015.
- Hayes, M. P. and D. M. Krempels. 1986. Vocal sac variation among frogs of the genus *Rana* from western North America. *Copeia* 1986(4):927-936.
- Holland, RF. 1986. Preliminary Descriptions of the Terrestrial Natural Communities of California. Prepared for the California Department of Fish and Game, Sacramento, CA.
- Information Center for the Environment (ICE). 2015. Distribution Maps of Fishes in California. Department of Environmental Science and Policy, University of California, Davis. Online at: <http://ice.ucdavis.edu/aquadiv/fishcovs/fishmaps.html>. Most recently accessed: May 2015.
- Jennings, M. R. and M. P. Hayes. 1985. Pre-1900 overharvest of California red-legged frogs (*Rana aurora draytonii*): The inducement for bullfrog (*Rana catesbeiana*) introduction. *Herpetological Review* 32(1):94-103.
- Jennings, MR and MP Hayes. 1994. Amphibian and Reptile Species of Special Concern in California. California Department of Fish and Game. Sacramento, CA.
- Jennings, MR. 2004. An Annotated Check List of Amphibians and Reptile Species of California and Adjacent Waters, third revised edition. California Department of Fish and Game, Sacramento, CA.
- Jepson Flora Project (eds.). 2015. Jepson eFlora. Available online at: <http://ucjeps.berkeley.edu/IJM.html>. Most recently accessed July 2015.
- Kelly, M, KA Tuxen, and FR Kearns. 2004. Geospatial informatics for management of a new forest disease: Sudden Oak Death. *Photogrammetric Engineering and Remote Sensing* 70(9): 1001-1004.
- Kelly, NM, and K Tuxen. 2003. WebGIS for sudden oak in coastal California. *Computers, Environment and Urban Systems* 27(5): 527-547

- Lake, D. 2010. Rare, Unusual, and Significant Plants of Alameda and Contra Costa Counties, 8<sup>th</sup> Edition. California Native Plant Society, East Bay Chapter. March 15, 2010.
- Lowther, Peter E. 2000. Nuttall's Woodpecker (*Picoides nuttallii*), The Birds of North America Online (A. Poole, Ed.). Ithaca: Cornell Lab of Ornithology; Retrieved from the Birds of North America Online:<http://bna.birds.cornell.edu/bna/species/555>
- Matocq, M. 2003. Dusky-footed Woodrats (*Neotoma fuscipes*) at Hastings: A Research Tradition. Hastings Natural History Reservation. Available online at: <http://www.hastingsreserve.org/Woodrats/DFwoodrats.html>.
- Mitchell, DE. 2000. Allen's Hummingbird (*Selasphorus sasin*), The Birds of North America Online (A Poole, Ed.). Ithaca: Cornell Lab of Ornithology; Retrieved from the Birds of North America Online:<http://bna.birds.cornell.edu/bna/species/501>.
- NatureServe. 2010. NatureServe Conservation Status. Available online at: <http://explorer.natureserve.org/ranking.htm>.
- Naval Facilities Engineering Command and City of Oakland. 1998. Final Environmental Impact Statement/ Environmental Impact Report. Disposal and Reuse of Naval Medical Center, Oakland. 1998. April.
- [NETR] Nationwide Environmental Title Research. 2015. Historic Aerials. Available online at: <http://www.historicaerials.com/>. Most recently accessed: July 2015.
- [NRCS] Natural Resources Conservation Service. 2010. Field Indicators of Hydric Soils in the United States, version 7.0. In cooperation with the National Technical Committee for Hydric Soils, Fort Worth, TX.
- Oak Knoll Coalition. 2015. History and Timeline. Available online at: <http://www.oakknollcoalition.org/>. Most recently accessed: July 2015.
- Oak Woodland Conservation Act. 2004. State of California Public Resources Code, Division 13, Chapter 2.6, Section 21083.4.
- Richmond, B., H. Green, D. C. Rice, H. Peeters. 2011. Alameda County breeding Bird Atlas. Golden Gate Audubon Society. 219 p.
- Safford, H.D., J.H. Viers, and S.P. Harrison. 2005. Serpentine Endemism in the California Flora: A Database of Serpentine Affinity. Madroño, vol52(4): pp. 222-257.
- Shuford, WD, and T Gardali (eds). 2008. California Bird Species of Special Concern: A ranked assessment of species, subspecies, and distinct populations of birds of immediate conservation concern in California. Studies of Western Birds 1. Western Field Ornithologists, Camarillo, California, and CDFG, Sacramento.
- Sowers, JM. 2000. Creek & Watershed Map of Oakland & Berkeley. William Lettis & Associates, Inc. Published by Oakland Museum of California, Oakland, CA. Online at: [http://www.acgov.org/aceh/lop/Oakland-Berkeley\\_Creek\\_Map.pdf](http://www.acgov.org/aceh/lop/Oakland-Berkeley_Creek_Map.pdf)

- Stebbins, RC. 2003. A Field Guide to Western Reptiles and Amphibians, third edition. The Peterson Field Guide Series, Houghton Mifflin Company, NY.
- Swaim, K.E. 1998. Aspects of the ecology of the Alameda whipsnake *Masticophis lateralis euryxanthus*. M.S. Thesis. California State University, Hayward. 140 pp.
- Swaim, K. E. 1996. The Status of the Alameda whipsnake (*Masticophis lateralis euryxanthus*) at the Naval Medical Center Oakland. Report to TETRA TECH, Inc., San Francisco, CA.
- Swaim, K. E. 2006. Survey Results for the Alameda Whipsnake (*Masticophis lateralis euryxanthus*) at the Former Naval Medical Center in Oakland, Alameda County, California. Report to WRA, Inc., San Rafael, CA
- Swiecki, T. J. and E. A. Bernhardt. 2013. A reference manual for managing sudden oak death in California. Gen. Tech. Rep. PSW-GTR-242. Albany, California: U.S. Department of Agriculture, Forest Service, Pacific Southwest Research Station. 129 p.
- [USDA] United States Department of Agriculture. 1981. Soil Survey of Alameda County, California. Natural Resources Conservation Service.
- [USGS] United States Geological Survey. 2015. Oakland East 7.5-minute Quadrangle map.
- [USFWS] United States Fish and Wildlife Service. 1996. Endangered and Threatened Wildlife and Plants; Determination of Threatened Status for the California Red-Legged Frog. Final Rule. Federal Register, Vol. 61, No. 101. 25813-25833. May 23.
- [USFWS] United States Fish and Wildlife Service. 1997. Endangered and Threatened Wildlife and Plants; Determination of Endangered Status for the Callippe Silverspot Butterfly and the Behren's Silverspot Butterfly and Threatened Status for the Alameda Whipsnake; Final Rule. Federal Register, Vol. 62, No. 234. 64306-64320. December 5.
- [USFWS] United States Fish and Wildlife Service. 2000. Endangered and threatened wildlife and plants; final determination of critical habitat for the Alameda Whipsnake (*Masticophis lateralis euryxanthus*). (65:192 FR October 3, 2000).
- [USFWS] United States Fish and Wildlife Service. 2001. Endangered and Threatened Wildlife and Plants; Final Determinations of Critical Habitat for the California Red-legged Frog; Final Rule. Vol. 66, No. 14626-14674
- [USFWS] United States Fish and Wildlife Service. 2002. Recovery plan for the California red-legged frog (*Rana aurora draytonii*). U.S. Fish and Wildlife Service, Portland, OR.
- [USFWS] United States Fish and Wildlife Service. 2006a. Alameda Whipsnake Critical Habitat Final Rule. October 2, 2006. Federal Register, Vol. 71, No. 190: 58176-58231.
- [USFWS] United States Fish and Wildlife Service. 2006b. Designation of Critical Habitat for the California Red-Legged Frog, and Special Rule Exemption Associated With Final Listing for Existing Routine Ranching Activities; Final Rule. Federal Register 71(71): 19243-19346. April 13.

- [USFWS] United States Fish and Wildlife Service. 2010. Endangered and Threatened Wildlife and Plants: Revised Designation of Critical Habitat for California Red-legged Frog; Final Rule. Federal Register, Vol. 75, No. 51. 12815-12959.
- [USFWS] United States Fish and Wildlife Service. 2012. 5 year Reviews of Species in California and Nevada. April 27, 2012. Federal Register, Vol. 77, No. 25112-25116
- [USFWS] United States Fish and Wildlife Service. 2015. Species Lists, Sacramento Fish and Wildlife Office. Available online at: <http://www.fws.gov/sacramento>; most recently accessed: July 2015.
- [WRA] WRA, Inc. 2006. Rare Plant Report, Former Oak Knoll Hospital, Oakland, Alameda County, California.
- [WRA] WRA, Inc. 2007. Delineation of Potential Jurisdictional Wetlands and Non-Wetland Waters Under Section 404 of the Clean Water Act, Former Oak Knoll Hospital, Oakland, Alameda County, California.
- [WRA] WRA, Inc. 2015a. Biological Resources Assessment, Oak Knoll, Oakland, Alameda County, California.
- [WRA] WRA, Inc. 2015b. Delineation of Potential Jurisdictional Wetlands and Non-Wetland Waters Under Section 404 of the Clean Water Act, Hardenstine Parcel, Oakland, Alameda County, California.
- [WRA] WRA, Inc. 2015c. Rare Plant Survey Report, Oak Knoll (APNs: 043A-4675-003-21 & 043A-4675-47-1), Oakland, Alameda County, California.
- [WRA] WRA, Inc. 2015d. Riparian Restoration and Monitoring Plan, Oak Knoll, Oakland, Alameda County, California.
- [WRA] WRA, Inc. 2017. Delineation of Potential Jurisdictional Wetlands and Non-Wetland Waters Under Section 404 of the Clean Water Act, Keller Parcel, Oakland, Alameda, County, California.
- Zeiner, DC, WF Laudenslayer, Jr., KE Mayer, and M White. 1990. California's Wildlife, Volume I-III: Amphibians and Reptiles, Birds, Mammals. California Statewide Wildlife Habitat Relationships System, California Department of Fish and Game, Sacramento, CA.

APPENDIX A

LIST OF OBSERVED PLANT SPECIES

**Appendix A.** Plant Species Observed in the Study Area in January 2017.

FAMILY	SCIENTIFIC NAME	COMMON NAME	PHENOLOGY AND FORM	ORIGIN	RARE STATUS	INVASIVE STATUS	EAST BAY CNPS UNUSUAL & SIGNIFICANT PLANTS RANK
Aceraceae	<i>Acer macrophyllum</i>	Bigleaf maple	deciduous tree	native	--	--	--
Adoxaceae [Caprifoliaceae]	<i>Sambucus nigra</i> ssp. <i>caerulea</i> [S. <i>mexicana</i> ]	Blue elderberry	deciduous shrub	native	--	--	--
Alliaceae [Liliaceae]	<i>Allium triquetrum</i>	Threecorner leek	perennial forb	non-native	--	assessed	--
Araliaceae	<i>Hedera helix</i>	English ivy	evergreen vine	non-native	--	high	--
Asteraceae	<i>Dittrichia graveolens</i>	Stinkwort	annual forb	non-native	--	moderate	--
Fabaceae	<i>Genista monspessulana</i>	French broom	evergreen shrub	non-native	--	high	--
Fagaceae	<i>Quercus agrifolia</i> var. <i>agrifolia</i>	Coast live oak	evergreen tree	native	--	--	A2
Fagaceae	<i>Quercus ilex</i>	Holly oak	evergreen tree	non-native	--	--	--
Lauraceae	<i>Umbellularia californica</i>	California bay	evergreen tree	native	--	--	--
Pinaceae	<i>Pinus pinea</i>	Italian stone pine	evergreen tree	non-native	--	--	--
Pinaceae	<i>Pinus radiata</i>	Monterey pine	evergreen tree	non-native	--	--	--
Rosaceae	<i>Prunus cerasifera</i>	Cherry plum	deciduous tree	non-native	--	--	--
Rosaceae	<i>Rubus armeniacus</i> [R. <i>discolor</i> ]	Himalayan blackberry	evergreen shrub	non-native	--	high	--
Rosaceae	<i>Rubus ursinus</i>	California blackberry	evergreen shrub	native	--	--	--
Salicaceae	<i>Salix lasiolepis</i>	arroyo willow	deciduous tree	native	--	--	--

FAMILY	SCIENTIFIC NAME	COMMON NAME	PHENOLOGY AND FORM	ORIGIN	RARE STATUS	INVASIVE STATUS	EAST BAY CNPS UNUSUAL & SIGNIFICANT PLANTS RANK
Sapindaceae [Hippocastanaceae]	<i>Aesculus californica</i>	California buckeye	deciduous tree	native	--	--	--



APPENDIX B

POTENTIAL FOR SPECIAL-STATUS SPECIES  
TO OCCUR IN THE STUDY AREA

**Appendix B.** Potential for special-status species to occur in the Study Area. List compiled from U.S. Fish and Wildlife Service (USFWS) IPaC Trust Report, a search of the California Department of Fish and Wildlife Natural Diversity Database (CDFW 2015b) and the California Native Plant Society Inventory of Rare and Endangered Plants (CNPS 2015a) for the Oakland East USGS 7.5' quadrangle and eight surrounding quadrangles (USGS 2015).

SPECIES	STATUS*	HABITAT	POTENTIAL FOR OCCURRENCE**	RECOMMENDATIONS
<b>Plants</b>				
bent-flowered fiddleneck <i>Amsinckia lunaris</i>	Rank 1B.2	Coastal bluff scrub, cismontane woodland, valley and foothill grassland. Elevation ranges from 10 to 1640 feet (3 to 500 meters). Blooms March-June.	<b>Not Present.</b> There is no suitable habitat within the Study Area. This species was historically documented in the Oakland Hills area in 1932 and the nearest extant occurrence is located approximately 3.5 miles north of the Study Area (USFWS 2015).	No further actions are recommended for this species.
California androsace <i>Androsace elongata</i> ssp. <i>acuta</i>	Rank 4.2	Chaparral, cismontane woodland, coastal scrub, meadows and seeps, pinyon and juniper woodland, valley and foothill grassland. Elevation ranges from 490 to 3940 feet (150 to 1200 meters). Blooms March-June.	<b>Not Present.</b> There are no documented occurrence records in the Study Vicinity and only a small portion of the Study Area is within the documented elevation range for this species.	No further actions are recommended for this species.
pallid manzanita <i>Arctostaphylos pallida</i>	FT, SE, Rank 1B.1	Broadleafed upland forest, closed-cone coniferous forest, chaparral, cismontane woodland, coastal scrub/siliceous shale, sandy or gravelly. Elevation ranges from 610 to 1530 feet (185 to 465 meters). Blooms December-March.	<b>Not Present.</b> The nearest documented occurrence is located approximately 3.2 miles north of the Study Area in Joaquin Miller Regional Park; however, the Study Area lacks suitable substrate (siliceous shale or thin chert).	No further actions are recommended for this species.

SPECIES	STATUS*	HABITAT	POTENTIAL FOR OCCURRENCE**	RECOMMENDATIONS
alkali milk-vetch <i>Astragalus tener</i> var. <i>tener</i>	Rank 1B.2	Playas, valley and foothill grassland (adobe clay), vernal pools/alkaline. Elevation ranges from 0 to 200 feet (1 to 60 meters). Blooms March-June.	<b>Not Present.</b> The Study Area lacks suitable mesic alkaline habitats.	No further actions are recommended for this species.
San Joaquin spearscale <i>Atriplex joaquinana</i>	Rank 1B.2	Chenopod scrub, meadows and seeps, playas, valley and foothill grassland/alkaline. Elevation ranges from 0 to 2740 feet (1 to 835 meters). Blooms April-October.	<b>Not Present.</b> The Study Area lacks suitable mesic alkaline habitats.	No further actions are recommended for this species.
big-scale balsamroot <i>Balsamorhiza macrolepis</i>	Rank 1B.2	Chaparral, cismontane woodland, valley and foothill grassland/sometimes serpentine. Elevation ranges from 300 to 5100 feet (90 to 1555 meters). Blooms March-June.	<b>Not Present.</b> The nearest documented occurrence of this species is located approximately 3.0 miles south of the Study Area, at Fairmont Ridge (USFWS 2015). However, this species was not detected during protocol-level, floristic rare plant surveys.	No further actions are recommended for this species.
big tarplant <i>Blepharizonia plumosa</i>	Rank 1B.1	Valley and foothill grassland/usually clay. Elevation ranges from 100 to 1660 feet (30 to 505 meters). Blooms July-October.	<b>Not Present.</b> There are no documented occurrence records in the Study Vicinity and the Study Area lacks suitable native grassland habitat with clay soils.	No further actions are recommended for this species.

SPECIES	STATUS*	HABITAT	POTENTIAL FOR OCCURRENCE**	RECOMMENDATIONS
round-leaved filaree <i>California macrophylla</i>	Rank 1B.1	Cismontane woodland, valley and foothill grassland/clay. Elevation ranges from 50 to 3940 feet (15 to 1200 meters). Blooms March-May.	<b>Not Present.</b> The Study Area lacks suitable native grassland habitat with clay soils. This species was historically documented in the Oakland Hills area in 1891 (USFWS 2015); however, there are no recent records of this species in the Study Vicinity.	No further actions are recommended for this species.
Mt. Diablo fairy-lantern <i>Calochortus pulchellus</i>	Rank 1B.2	Chaparral, cismontane woodland, riparian woodland, valley and foothill grassland. Elevation ranges from 100 to 2760 feet (30 to 840 meters). Blooms April-June.	<b>Not Present.</b> There are no documented occurrence records in the Study Vicinity.	No further actions are recommended for this species.
Oakland star-tulip <i>Calochortus umbellatus</i>	Rank 4.2	Broadleaved upland forest, chaparral, cismontane woodland, lower montane coniferous forest, valley and foothill grassland/often serpentine. Elevation ranges from 330 to 2300 feet (100 to 700 meters). Blooms March-May.	<b>Not Present.</b> Approximately 723 individuals of this species were observed in the adjacent Oak Knoll Development Area. No individuals were located within the Study Area.	No further actions are recommended for this species.
coastal bluff morning-glory <i>Calystegia purpurata</i> ssp. <i>saxicola</i>	Rank 1B.2	Coastal bluff scrub, coastal dunes, coastal scrub, north coast coniferous forest. Elevation ranges from 30 to 340 feet (10 to 105 meters). Blooms (March), April-September.	<b>Not Present.</b> The Study Area lacks suitable coastal habitats.	No further actions are recommended for this species.

SPECIES	STATUS*	HABITAT	POTENTIAL FOR OCCURRENCE**	RECOMMENDATIONS
johnny-nip <i>Castilleja ambigua</i> var. <i>ambigua</i>	Rank 4.2	Coastal bluff scrub, coastal prairie, coastal scrub, marshes and swamps, valley and foothill grassland, vernal pool margins. Elevation ranges from 0 to 1430 feet (0 to 435 meters). Blooms March-August.	<b>Not Present.</b> The Study Area lacks suitable mesic coastal habitats.	No further actions are recommended for this species.
Congdon's tarplant <i>Centromadia parryi</i> ssp. <i>congonii</i>	Rank 1B.1	Valley and foothill grassland (alkaline). Elevation ranges from 0 to 750 feet (0 to 230 meters). Blooms May-October (November).	<b>Not Present.</b> The Study Area lacks suitable mesic alkaline habitats.	No further actions are recommended for this species.
Point Reyes bird's-beak <i>Chloropyron maritimum</i> ssp. <i>palustre</i>	Rank 1B.2	Marshes and swamps (coastal salt). Elevation ranges from 0 to 30 feet (0 to 10 meters). Blooms June-October.	<b>Not Present.</b> The Study Area lacks coastal salt marsh habitat.	No further actions are recommended for this species.
San Francisco Bay spineflower <i>Chorizanthe cuspidata</i> var. <i>cuspidata</i>	Rank 1B.2	Coastal bluff scrub, coastal dunes, coastal prairie, coastal scrub/sandy. Elevation ranges from 10 to 710 feet (3 to 215 meters). Blooms April-July (August).	<b>Not Present.</b> The Study Area lack suitable coastal habitats with sandy soils.	No further actions are recommended for this species.
robust spineflower <i>Chorizanthe robusta</i> var. <i>robusta</i>	FE, Rank 1B.1	Chaparral (maritime), cismontane woodland (openings), coastal dunes, coastal scrub/sandy or gravelly. Elevation ranges from 10 to 980 feet (3 to 300 meters). Blooms April-September.	<b>Not Present.</b> The Study Area lack suitable coastal habitats with sandy or gravelly soils.	No further actions are recommended for this species.

SPECIES	STATUS*	HABITAT	POTENTIAL FOR OCCURRENCE**	RECOMMENDATIONS
Franciscan thistle <i>Cirsium andrewsii</i>	Rank 1B.2	Broadleafed upland forest, coastal bluff scrub, coastal prairie, coastal scrub/mesic, sometimes serpentine. Elevation ranges from 0 to 490 feet (0 to 150 meters). Blooms March-July.	<b>Not Present.</b> The Study Area lacks mesic serpentine habitat.	No further actions are recommended for this species.
Santa Clara red ribbons <i>Clarkia concinna</i> ssp. <i>automixa</i>	Rank 4.3	Chaparral, cismontane woodland. Elevation ranges from 300 to 4920 feet (90 to 1500 meters). Blooms (April), May-June (July).	<b>Not Present.</b> This species was historically documented in the Oakland Hills area in 1936 (USFWS 2015); however, there are no recent records of this species in the Study Vicinity.	No further actions are recommended for this species.
Presidio clarkia <i>Clarkia franciscana</i>	FE, SE, Rank 1B.1	Coastal scrub, valley and foothill grassland (serpentine). Elevation ranges from 80 to 1100 feet (25 to 335 meters). Blooms May-July.	<b>Not Present.</b> There are several documented occurrences of this species in or near the Skyline Serpentine Prairie Preserve, approximately 2.5 miles northwest of the Study Area; however, this species is a strict serpentine endemic and the Study Area lacks suitable serpentine substrates.	No further actions are recommended for this species.

SPECIES	STATUS*	HABITAT	POTENTIAL FOR OCCURRENCE**	RECOMMENDATIONS
western leatherwood <i>Dirca occidentalis</i>	Rank 1B.2	Broadleaved upland forest, closed-cone coniferous forest, chaparral, cismontane woodland, north coast coniferous forest, riparian forest, riparian woodland/mesic. Elevation ranges from 80 to 1390 feet (25 to 425 meters). Blooms January-March (April).	<b>Not Present.</b> The coast live oak woodland in the Study Area provides suitable habitat. There are several documented occurrence records of this species in the Study Vicinity, including an extant occurrence approximately 1.7 miles north of the Project Site in Chabot Regional Park. However, this species was not detected during protocol-level, floristic rare plant surveys.	No further actions are recommended for this species.
Tiburon buckwheat <i>Eriogonum luteolum</i> var. <i>caninum</i>	Rank 1B.2	Chaparral, cismontane woodland, coastal prairie, valley and foothill grassland/serpentine, sandy to gravelly. Elevation ranges from 0 to 2300 feet (0 to 700 meters). Blooms May-September.	<b>Not Present.</b> There are several documented occurrences of this species in or near the Skyline Serpentine Prairie Preserve, approximately 2.5 miles northwest of the Study Area; however, this species is a strict serpentine endemic and the Study Area lacks suitable serpentine substrates.	No further actions are recommended for this species.
minute pocket moss <i>Fissidens pauperculus</i>	Rank 1B.2	North coast coniferous forest (damp coastal soil). Elevation ranges from 30 to 3360 feet (10 to 1024 meters).	<b>Not Present.</b> The Study Area lacks suitable coniferous forest habitat.	No further actions are recommended for this species.

SPECIES	STATUS*	HABITAT	POTENTIAL FOR OCCURRENCE**	RECOMMENDATIONS
fragrant fritillary <i>Fritillaria liliacea</i>	Rank 1B.2	Cismontane woodland, coastal prairie, coastal scrub, valley and foothill grassland/often serpentine. Elevation ranges from 10 to 1350 feet (3 to 410 meters). Blooms February-April.	<b>Not Present.</b> The Study Area lacks suitable undisturbed grassland habitat. This species was documented approximately 1.7 miles northwest of the Study Area in 1920 (USFWS 2015); however, this population is likely extirpated. The nearest extant occurrence is located approximately 3.3 miles south of the Study Area, at Fairmont Ridge (USFWS 2015).	No further actions are recommended for this species.
blue coast gilia <i>Gilia capitata</i> ssp. <i>chamissonis</i>	Rank 1B.1	Coastal dunes, coastal scrub. Elevation ranges from 10 to 660 feet (2 to 200 meters). Blooms April-July.	<b>Not Present.</b> The Study Area lacks suitable coastal habitats.	No further actions are recommended for this species.
Diablo helianthella <i>Helianthella castanea</i>	Rank 1B.2	Broadleafed upland forest, chaparral, cismontane woodland, coastal scrub, riparian woodland, valley and foothill grassland. Elevation ranges from 200 to 4270 feet (60 to 1300 meters). Blooms March-June.	<b>Not Present.</b> The Study Area lacks suitable grassland and woodland habitats. There are several documented occurrences in the vicinity of the Project Area; the nearest is located approximately 1.8 miles west of the Project Site, on a ridge above Lake Chabot. However, this species was not detected during protocol-level surveys of the Project Area.	No further actions are recommended for this species.



SPECIES	STATUS*	HABITAT	POTENTIAL FOR OCCURRENCE**	RECOMMENDATIONS
Loma Prieta hoita <i>Hoita strobilina</i>	Rank 1B.1	Chaparral, cismontane woodland, riparian woodland/usually serpentine, mesic. Elevation ranges from 100 to 2820 feet (30 to 860 meters). Blooms May-July (August), (October).	<b>Not Present.</b> This species was historically documented in the Oakland Hills area in 1865 (USFWS 2015); however, there are no recent records of this species in the Study Vicinity.	No further actions are recommended for this species.
Santa Cruz tarplant <i>Holocarpha macradenia</i>	FT, SE, Rank 1B.1	Coastal prairie, coastal scrub, valley and foothill grassland/often clay, sandy. Elevation ranges from 30 to 720 feet (10 to 220 meters). Blooms June-October.	<b>Not Present.</b> This species is considered extirpated from Alameda County.	No further actions are recommended for this species.
Kellogg's horkelia <i>Horkelia cuneata</i> var. <i>sericea</i>	Rank 1B.1	Closed-cone coniferous forest, chaparral (maritime), coastal dunes, coastal scrub/sandy or gravelly, openings. Elevation ranges from 30 to 660 feet (10 to 200 meters). Blooms April-September.	<b>Not Present.</b> The Study Area lack suitable coastal habitats with sandy or gravelly soils.	No further actions are recommended for this species.
coast iris <i>Iris longipetala</i>	Rank 4.2	Coastal prairie, lower montane coniferous forest, meadows and seeps/mesic. Elevation ranges from 0 to 1970 feet (0 to 600 meters). Blooms March-May.	<b>Not Present.</b> The Study Area lacks suitable mesic coastal habitats.	No further actions are recommended for this species.
Southern California black walnut <i>Juglans californica</i>	Rank 4.2	Chaparral, cismontane woodland, coastal scrub/alluvial. Elevation ranges from 160 to 2950 feet (50 to 900 meters). Blooms March-August.	<b>Not Present.</b> This is an apparent database error. This species is restricted to Southern California and is not known to occur north of Santa Barbara County.	No further actions are recommended for this species.

SPECIES	STATUS*	HABITAT	POTENTIAL FOR OCCURRENCE**	RECOMMENDATIONS
Northern California black walnut <i>Juglans hindsii</i>	Rank 1B.1	Riparian forest, riparian woodland. Elevation ranges from 0 to 1440 feet (0 to 440 meters). Blooms April-May.	<b>Not Present.</b> Only native stands are considered rare; most stands are hybrid cultivars. There are no known native stands in Alameda County and the Study Area lacks suitable riparian habitat with deep alluvial soil.	No further actions are recommended for this species.
Contra Costa goldfields <i>Lasthenia conjugens</i>	FE, Rank 1B.1	Cismontane woodland, playas (alkaline), valley and foothill grassland, vernal pools/mesic. Elevation ranges from 0 to 1540 feet (0 to 470 meters). Blooms March-June.	<b>Not Present.</b> The Study Area lacks suitable mesic alkaline habitats.	No further actions are recommended for this species.
Delta tule pea <i>Lathyrus jepsonii</i> var. <i>jepsonii</i>	Rank 1B.2	Marshes and swamps (freshwater and brackish). Elevation ranges from 0 to 20 feet (0 to 5 meters). Blooms May-July (August), (September).	<b>Not Present.</b> The Study Area lacks suitable freshwater or brackish marsh habitat and is outside of the known elevation range for this species.	No further actions are recommended for this species.
bristly leptosiphon <i>Leptosiphon acicularis</i>	Rank 4.2	Chaparral, cismontane woodland, coastal prairie, valley and foothill grassland. Elevation ranges from 180 to 4920 feet (55 to 1500 meters). Blooms April-July.	<b>Not Present.</b> Grassland habitats in the Study Area do not provide suitable habitat for this species. The nearest known occurrence of this species is 0.9-mile south of the Study Area at Knowland Park (CCH 2015).	No further actions are recommended for this species.
Oregon meconella <i>Meconella oregana</i>	Rank 1B.1	Coastal prairie, coastal scrub. Elevation ranges from 820 to 2030 feet (250 to 620 meters). Blooms March-April.	<b>Not Present.</b> The Study Area lacks suitable mesic coastal habitats and is outside of the known elevation range for this species.	No further actions are recommended for this species.

SPECIES	STATUS*	HABITAT	POTENTIAL FOR OCCURRENCE**	RECOMMENDATIONS
Mt. Diablo cottonweed <i>Micropus amphibolus</i>	Rank 3.2	Broadleaved upland forest, chaparral, cismontane woodland, valley and foothill grassland/rocky. Elevation ranges from 150 to 2710 feet (45 to 825 meters). Blooms March-May.	<b>Not Present.</b> The Study Area lacks suitable habitat with rocky soils.	No further actions are recommended for this species.
San Antonio Hills monardella <i>Monardella antonina</i> ssp. <i>antonina</i>	Rank 3	Chaparral, cismontane woodland. Elevation ranges from 1050 to 3280 feet (320 to 1000 meters). Blooms June-August.	<b>Not Present.</b> The Study Area is outside of the known elevation range for this species.	No further actions are recommended for this species.
woodland woolythreads <i>Monolopia gracilens</i>	Rank 1B.2	Broadleaved upland forest (openings), chaparral (openings), cismontane woodland, north coast coniferous forest (openings), valley and foothill grassland/serpentine. Elevation ranges from 330 to 3940 feet (100 to 1200 meters). Blooms (February), March-July.	<b>Not Present.</b> This species was historically documented in the Oakland Hills area in 1888 (USFWS 2015); however, there are no recent records of this species in the Study Vicinity.	No further actions are recommended for this species.
Lime Ridge navarretia <i>Navarretia gowenii</i>	Rank 1B.1	Chaparral. Elevation ranges from 590 to 1000 feet (180 to 305 meters). Blooms May-June.	<b>Not Present.</b> There are no known occurrence records in the Study Vicinity and the majority of the Study Area is outside of the known elevation range for this species.	No further actions are recommended for this species.

SPECIES	STATUS*	HABITAT	POTENTIAL FOR OCCURRENCE**	RECOMMENDATIONS
Michael's rein orchid <i>Piperia michaelii</i>	Rank 4.2	Coastal bluff scrub, closed-cone coniferous forest, chaparral, cismontane woodland, coastal scrub, lower montane coniferous forest. Elevation ranges from 10 to 3000 feet (3 to 915 meters). Blooms April-August.	<b>Not Present.</b> There are no known occurrence records in the Study Vicinity.	No further actions are recommended for this species.
Choris' popcorn-flower <i>Plagiobothrys chorisianus</i> var. <i>chorisianus</i>	Rank 1B.2	Chaparral, coastal prairie, coastal scrub/mesic. Elevation ranges from 50 to 520 feet (15 to 160 meters). Blooms March-June.	<b>Not Present.</b> The Study Area lacks suitable mesic coastal habitat.	No further actions are recommended for this species.
San Francisco popcorn-flower <i>Plagiobothrys diffusus</i>	SE, Rank 1B.1	Coastal prairie, valley and foothill grassland. Elevation ranges from 200 to 1180 feet (60 to 360 meters). Blooms March-June.	<b>Not Present.</b> The nearest documented occurrence is located approximately 2.4 miles northwest of the Study Area on a serpentine rock outcrop; however, there are no other known occurrence records in the Study Vicinity and the Study Area lack serpentine outcrops.	No further actions are recommended for this species.
hairless popcorn-flower <i>Plagiobothrys glaber</i>	Rank 1A	Meadows and seeps (alkaline), marshes and swamps (coastal salt). Elevation ranges from 50 to 590 feet (15 to 180 meters). Blooms March-May.	<b>Not Present.</b> The Study Area lacks coastal salt or alkaline meadow habitat.	No further actions are recommended for this species.
Marin knotweed <i>Polygonum marinense</i>	Rank 3.1	Marshes and swamps (coastal salt or brackish). Elevation ranges from 0 to 30 feet (0 to 10 meters). Blooms (April), May-August (October).	<b>Not Present.</b> The Study Area lacks coastal salt or brackish marsh habitat.	No further actions are recommended for this species.

SPECIES	STATUS*	HABITAT	POTENTIAL FOR OCCURRENCE**	RECOMMENDATIONS
Lobb's aquatic buttercup <i>Ranunculus lobbii</i>	Rank 4.2	Cismontane woodland, north coast coniferous forest, valley and foothill grassland, vernal pools/mesic. Elevation ranges from 50 to 1540 feet (15 to 470 meters). Blooms February-May.	<b>Not Present.</b> The Study Area lack suitable mesic habitats.	No further actions are recommended for this species.
adobe sanicle <i>Sanicula maritima</i>	SR, Rank 1B.1	Chaparral, coastal prairie, meadows and seeps, valley and foothill grassland/clay, serpentine. Elevation ranges from 100 to 790 feet (30 to 240 meters). Blooms February-May.	<b>Not Present.</b> The Study Area lacks suitable coastal mesic habitats with clay or serpentine soils.	No further actions are recommended for this species.
most beautiful jewel-flower <i>Streptanthus albidus</i> ssp. <i>peramoenus</i>	Rank 1B.2	Chaparral, cismontane woodland, valley and foothill grassland/serpentine. Elevation ranges from 310 to 3280 feet (95 to 1000 meters). Blooms (March), April-September (October).	<b>Not Present.</b> There are several nearby occurrence records of this species in the CNDDDB (USFWS 2015), including a 1994 occurrence record less than 1.0 mile south of the Project Site in Knowland Park. However, the Project Site lacks serpentine outcrops.	No further actions are recommended for this species.
slender-leaved pondweed <i>Stuckenia filiformis</i> ssp. <i>alpina</i>	Rank 2B.2	Marshes and swamps (assorted shallow freshwater). Elevation ranges from 980 to 7050 feet (300 to 2150 meters). Blooms May-July.	<b>Not Present.</b> The Study Area lacks suitable freshwater or brackish marsh habitat and is outside of the known elevation range for this species.	No further actions are recommended for this species.
California seablite <i>Suaeda californica</i>	FE, Rank 1B.1	Marshes and swamps (coastal salt). Elevation ranges from 0 to 50 feet (0 to 15 meters). Blooms July-October.	<b>Not Present.</b> The Study Area lacks coastal salt marsh habitat.	No further actions are recommended for this species.

SPECIES	STATUS*	HABITAT	POTENTIAL FOR OCCURRENCE**	RECOMMENDATIONS
saline clover <i>Trifolium hydrophilum</i>	Rank 1B.2	Marshes and swamps, valley and foothill grassland (mesic, alkaline), vernal pools. Elevation ranges from 0 to 980 feet (0 to 300 meters). Blooms April-June.	<b>Not Present.</b> The Study Area lacks suitable mesic alkaline habitats.	No further actions are recommended for this species.
oval-leaved viburnum <i>Viburnum ellipticum</i>	Rank 2B.3	Chaparral, cismontane woodland, lower montane coniferous forest. Elevation ranges from 710 to 4590 feet (215 to 1400 meters). Blooms May-June.	<b>Not Present.</b> There are no known occurrence records in the Study Vicinity and the Study Area is outside of the known elevation range for this species.	No further actions are recommended for this species.
<b>Wildlife</b>				
<b>Mammals</b>				
pallid bat <i>Antrozous pallidus</i>	SSC, WBWG High	Occupies a variety of habitats at low elevation including grasslands, shrublands, woodlands, and forests. Most common in open, dry habitats with rock crevices, tree hollows, mines, caves, and a variety of man-made structures for roosting.	<b>Unlikely.</b> The Study Area has moderate levels of anthropogenic disturbances. Trees within the Study Area do not typically offer the size or foliage structure required to support roosting by the species. No rock outcrops or suitable caves or mines are present to provide roosting habitat.	No further actions are recommended for this species.

SPECIES	STATUS*	HABITAT	POTENTIAL FOR OCCURRENCE**	RECOMMENDATIONS
Townsend's big-eared bat <i>Corynorhinus townsendii</i>	SCT, SSC, WBWG High	This species is associated with a wide variety of habitats from deserts to mid-elevation mixed coniferous-deciduous forest. Females form maternity colonies in buildings, caves and mines and males roost singly or in small groups. Foraging occurs in open forest habitats where they glean moths from vegetation.	<b>Unlikely.</b> The Study Area has moderate levels of anthropogenic disturbances. Trees within the Study Area do not typically offer the size or foliage structure required to support roosting by the species. No rock outcrops or suitable caves or mines are present to provide roosting habitat. The only known occurrence of the species within the search area was approximately 8.7 miles away and occurred in 1938.	No further actions are recommended for this species.
long-eared myotis <i>Myotis evotis</i>	WBWG medium	Found in all brush, woodland and forest habitats from sea level to about 9000 feet. Prefers coniferous woodlands and forests. Nursery colonies in buildings, crevices, spaces under bark, and snags. Caves used primarily as night roosts.	<b>No Potential.</b> The Study Area lacks the dense Douglas fir or redwood forests required to support roosting by the species.	No further actions are recommended for this species.
fringed myotis <i>Myotis thysanodes</i>	WBWG High	Associated with a wide variety of habitats including dry woodlands, desert scrub, mesic coniferous forest, grassland, and sage-grass steppes. Buildings, mines and large trees and snags are important day and night roosts.	<b>No Potential.</b> The Study Area occurs in a cool, moist region on the borders of San Francisco bay. The site lacks the dry woodland habitat required to support the species.	No further actions are recommended for this species.

SPECIES	STATUS*	HABITAT	POTENTIAL FOR OCCURRENCE**	RECOMMENDATIONS
<p>long-legged myotis <i>Myotis volans</i></p>	<p>WBWG High</p>	<p>Generally associated with woodlands and forested habitats. Large hollow trees, rock crevices and buildings are important day roosts. Other roosts include caves, mines and buildings.</p>	<p><b>Unlikely.</b> The Study Area lacks the dense forest and large trees required by the species for roosting. However, suitable habitat is found to the east of the Study Area within 2 miles, therefore the species may occasionally forage over the site.</p>	<p>No further actions are recommended for this species.</p>
<p>western mastiff bat <i>Eumops perotis</i></p>	<p>SSC, WBWG High</p>	<p>Found in a wide variety of open, arid and semi-arid habitats. Distribution appears to be tied to large rock structures which provide suitable roosting sites, including cliff crevices and cracks in boulders.</p>	<p><b>No Potential.</b> The Study Area is a former naval hospital with moderate levels of anthropogenic disturbances and developed surfaces throughout most of the area. Typical roosting habitat including large caves or mines is not present.</p>	<p>No further actions are recommended for this species.</p>



SPECIES	STATUS*	HABITAT	POTENTIAL FOR OCCURRENCE**	RECOMMENDATIONS
silver-haired bat <i>Lasionycteris noctivagans</i>	WBWG Medium	Summer habitats include coastal and montane coniferous forests, valley foothill woodlands, pinyon-juniper woodlands, and valley foothill and montane riparian habitats. This species is primarily a forest dweller, feeding over streams, ponds, and open brushy areas. It roosts in hollow trees, snags, buildings, rock crevices, caves, and under bark.	<b>Unlikely.</b> The Study Area has moderate levels of anthropogenic disturbances. Trees within the Study Area do not typically offer the size or foliage structure required to support roosting by the species. Typical roosting habitat such as large dry pine trees is uncommon in the Study Area. Foraging habitat within and surrounding the Study Area is also sub-optimal with only small patches of open, intact grassland.	No further actions are recommended for this species.
hoary bat <i>Lasiurus cinereus</i>	WBWG Medium	Prefers open habitats or habitat mosaics, with access to trees for cover and open areas or habitat edges for feeding. Roosts in dense foliage of medium to large trees. Feeds primarily on moths. Requires water.	<b>Unlikely.</b> The Study Area and surrounding habitats are poor quality foraging habitat. Roost trees with sufficient foliage structure and intact surrounding habitat are rare within the Study Area.	No further actions are recommended for this species.

SPECIES	STATUS*	HABITAT	POTENTIAL FOR OCCURRENCE**	RECOMMENDATIONS
San Francisco dusky-footed woodrat <i>Neotoma fuscipes annectens</i>	SSC	Forest habitats of moderate canopy and moderate to dense understory. Also in chaparral habitats. Constructs nests of shredded grass, leaves, and other material. May be limited by availability of nest-building materials.	<b>High Potential.</b> Middens constructed by the species were observed during tree surveys within the Former Naval Medical Center Parcel. The species may be rare within the site due to the primarily developed nature of the area and limited expanses of forest that are required to provide adequate nesting material.	Conduct a pre-construction survey prior to vegetation removal and/or ground disturbance within the Study Area. Any woodrat structures found during the survey shall be flagged and avoided to the fullest extent possible. If avoidance is not possible, then structures to be impacted shall be dismantled by hand under the supervision of a qualified biologist.
Alameda Island mole <i>Scapanus latimanus parvus</i>	SSC	Only known from Alameda Island. Found in a variety of habitats, especially annual and perennial grasslands. Prefers moist, friable soils. Avoids flooded soils.	<b>No Potential.</b> The Study Area is outside of the known range.	No further actions are recommended for this species.
American badger <i>Taxidea taxus</i>	SSC	Most abundant in drier open stages of most shrub, forest, and herbaceous habitats, with friable soils. Requires friable soils and open, uncultivated ground. Preys on burrowing rodents.	<b>No Potential:</b> The Study Area contains predominantly developed surfaces with little friable soils. In addition, the Study Area receives a high level of anthropogenic disturbance and the preferred prey species of badgers are not common.	No further actions are recommended for this species.

SPECIES	STATUS*	HABITAT	POTENTIAL FOR OCCURRENCE**	RECOMMENDATIONS
salt marsh wandering shrew <i>Sorex vagrans halicoetes</i>	SSC	Seldom observed; endemic to salt-marshes of the south arm of San Francisco Bay. Typically in medium to high marsh where abundant driftwood is scattered among pickleweed.	<b>No Potential.</b> No salt marsh habitat is present within or near the Study Area; no suitable habitat for this species is present.	No further actions are recommended for this species.
salt marsh harvest mouse <i>Reithrodontomys raviventris</i>	FE, SE, CFP	Occurs in pickleweed and dense vegetation habitats in tidal, muted-tidal, and diked areas.	<b>No Potential.</b> No salt marsh habitat is present within or near the Study Area; no suitable habitat for this species is present.	No further actions are recommended for this species.

SPECIES	STATUS*	HABITAT	POTENTIAL FOR OCCURRENCE**	RECOMMENDATIONS
Birds				
bald eagle <i>Haliaeetus leucocephalus</i>	FD, SE, CFP	Generally a winter visitor; breeding in the vicinity of San Francisco Bay is very limited. Requires large bodies of water, or free-flowing rivers with abundant fish adjacent snags or other perches. Nests in large, old-growth, or dominant live tree with open branchwork.	<b>No Potential.</b> Suitable large water bodies which are required to support prey species are not found within 1.5 miles of the Study Area. More suitable habitat is found to the east or southeast of the Study Area near Upper San Leandro Reservoir or Lake Chabot. This species may pass over the Study Area, but no suitable nesting or foraging habitat is present.	No further actions are recommended for this species.
Swainson's hawk <i>Buteo swainsoni</i>	ST, BCC	Summer resident in California's Central Valley and limited portions of the southern California interior. Nests in tree groves and isolated trees in riparian and agricultural areas, including near buildings. Forages in grasslands and scrub habitats as well as agricultural fields, especially alfalfa.	<b>No Potential.</b> The Study Area is not within the current breeding distribution of the species.	No further actions are recommended for this species.
black oystercatcher <i>Haematopus bachmani</i>	BCC	Year-round resident of rocky coast habitats along the Pacific coast. Also occurs on coastal and lower estuarine mud-flats. Forages primarily on intertidal invertebrates.	<b>No Potential.</b> No coastal or shoreline habitat is present within or near the Study Area.	No further actions are recommended for this species.

SPECIES	STATUS*	HABITAT	POTENTIAL FOR OCCURRENCE**	RECOMMENDATIONS
Bell's sage sparrow <i>Amphispiza belli belli</i>	BCC, SSC	Year-round resident though shows seasonal movements. Prefers dense chaparral and scrub habitats for breeding; strongly associated with chamise. Also occurs in more open habitats during winter.	<b>No Potential.</b> The Study Area has moderate levels of anthropogenic disturbances. The species requires expanses of dry chaparral habitat which are not found within the Study Area.	No further actions are recommended for this species.
black skimmer <i>Rynchops niger</i>	BCC, SSC	(Nesting colony) Nests along the north and south ends of the Salton Sea; also, on salt pond dikes of south San Diego bay. Nests on gravel bars, low islets, and sandy beaches, in unvegetated sites. Nesting colonies usually less than 200 pairs.	<b>No Potential.</b> The Study Area does not contain suitable habitat such as sandy or salt pond habitats for this species.	No further actions are recommended for this species.
golden eagle <i>Aquila chrysaetos</i>	CFP	Resident in rolling foothill and mountain areas, sage-juniper flats, and desert. Cliff-walled canyons provide nesting habitat in most parts of range.	<b>No Potential.</b> The Study Area does not contain nesting habitat and the typical open habitats for foraging are not present. More suitable habitat occurs approximately 1.5 miles east near Upper San Leandro Reservoir.	No further actions are recommended for this species.

SPECIES	STATUS*	HABITAT	POTENTIAL FOR OCCURRENCE**	RECOMMENDATIONS
ferruginous hawk <i>Buteo regalis</i>	BCC	Winter visitor; does not nest in the vicinity San Francisco Bay. Occurs in open habitats, including grasslands, low foothills surrounding valleys, and agricultural areas.	<b>Unlikely.</b> The Study Area is surrounded by development, limiting foraging habitat.	No further actions are recommended for this species.
northern harrier <i>Circus cyaneus</i>	SSC	Coastal salt and freshwater marsh. Nest and forage in grasslands, from salt grass in desert sink to mountain cienagas. Nests on ground in shrubby vegetation, usually at marsh edge; nest built of a large mound of sticks in wet areas.	<b>Unlikely.</b> Marsh and grassland habitat suitable for this species is not present within the Study Area. The Study Area contains predominantly developed surfaces.	No further actions are recommended for this species.
Allen's hummingbird <i>Selasphorus sasin</i>	BCC	(Nesting) Inhabits mixed evergreen, riparian woodlands, eucalyptus and cypress groves, oak woodlands, and coastal scrub during breeding season. Nest in shrubs and trees with dense vegetation.	<b>High potential.</b> The species has been confirmed in the area by both Richmond et al (2011) and by observations recorded on eBird (2015). Suitable habitat is present within the Study Area.	Work windows or pre-construction nesting bird surveys. See section 6 for additional measures.
prairie falcon <i>Falco mexicanus</i>	BCC	Resident and winter visitor. Inhabits dry, open terrain. Breeding sites are located on cliffs; forages widely. Prey upon a variety of vertebrates, mostly mammals and birds.	<b>No Potential.</b> There are no cliffs or large geologic features to support nesting by the species.	No further actions are recommended for this species.

SPECIES	STATUS*	HABITAT	POTENTIAL FOR OCCURRENCE**	RECOMMENDATIONS
olive-sided flycatcher <i>Contopus cooperi</i>	SSC, BCC	Summer resident. Typical breeding habitat is montane coniferous forests. At lower elevations, also occurs in wooded canyons and mixed forests and woodlands. Arboreal nest sites located well off the ground.	<b>Moderate Potential.</b> The riparian trees within the Study Area provides suitable nesting habitat. The species has been recorded within the local area (eBird 2015).	Work windows or pre-construction nesting bird surveys. See section 6 for additional measures.
white-tailed kite <i>Elanus leucurus</i>	CFP	Year-long resident of coastal and valley lowlands. Preys on small diurnal mammals and occasional birds, insects, reptiles, and amphibians.	<b>Unlikely.</b> The typical open grassland habitat used for foraging is not present. The species may be seen flying over the Study Area.	No further actions are recommended for this species.
burrowing owl <i>Athene cunicularia</i>	SSC, BCC	Largely resident in the region. Found in grasslands and other open habitats with a sparse to absent shrub/tree canopy. Nests and roosts in old mammal burrows, typically those of ground squirrels. Preys upon insects, and also small mammals, reptiles and birds.	<b>Unlikely.</b> The Study Area contains developed surfaces, and ground squirrel's burrows or burrow surrogates were not observed on the site. Short grasslands and open habitats are extremely limited within the Study Area.	No further actions are recommended for this species.
long-billed curlew <i>Numenius americanus</i>	BCC	(Nesting) breeds in upland shortgrass prairies and wet meadows in northeastern California. Habitats on gravelly soils and gently rolling terrain are favored over others	<b>No Potential.</b> The species does not breed in Alameda County.	No further actions are recommended for this species.

SPECIES	STATUS*	HABITAT	POTENTIAL FOR OCCURRENCE**	RECOMMENDATIONS
American peregrine falcon <i>Falco peregrinus anatum</i>	FD, SD, CFP, BCC,	Year-round resident and winter visitor. Occurs in a wide variety of habitats, though often associated with coasts, bays, marshes and other bodies of water. Nests on protected cliffs and also on man-made structures including buildings and bridges. Preys on birds, especially waterbirds. Forages widely.	<b>Unlikely.</b> There are no large cliffs or tall man-made structures within the Study Area to support nesting by the species. Typical foraging habitat is not present; however, this species may be observed on rare occasion foraging in the Study Area.	No further actions are recommended for this species.
grasshopper sparrow <i>Ammodramus savannarum</i>	SSC	Summer resident. Breeds in open grasslands, generally with low- to moderate-height grasses and scattered shrubs. Well-hidden nests are placed on the ground.	<b>Unlikely.</b> Sparse ruderal grasslands present within the Study Area are not of sufficient height or density to support nesting and foraging by the species.	No further actions are recommended for this species.
oak titmouse <i>Baeolophus inornatus</i>	BCC	Occurs year-round in woodland and savannah habitats where oaks are present, as well as riparian areas. Nests in tree cavities.	<b>High Potential.</b> This species was observed during the site visit to the Former Naval Medical Center Parcel, and suitable nesting habitat is present in the oak woodland and riparian habitats within the Study Area.	Work windows or pre-construction nesting bird surveys. See section 6 for additional measures.



SPECIES	STATUS*	HABITAT	POTENTIAL FOR OCCURRENCE**	RECOMMENDATIONS
Nuttall's woodpecker <i>Picoides nuttallii</i>	BCC	Year-round resident in lowland woodlands throughout much of California west of the Sierra Nevada. Typical habitat is dominated by oaks; also occurs in riparian woodland. Nests in tree cavities.	<b>High Potential.</b> This species was observed during the site visit to the Former Naval Medical Center Parcel, and suitable nesting habitat is present in the oak woodland and riparian habitats within the Study Area.	Work windows or pre-construction nesting bird surveys. See section 6 for additional measures.
yellow-billed magpie <i>Pica nuttalli</i>	BCC	(Nesting & communal roosts) Oak savanna with large trees and large expanses of open ground. The Central Valley floor, gentle slopes, and open park-like areas including along stream courses. Grasslands, pasture, or cultivated fields are needed for foraging.	<b>No Potential.</b> This species primarily nests within the southeastern portions of Alameda County (Richmond et al. 2011)	No further actions are recommended for this species.
loggerhead shrike <i>Lanius ludovicianus</i>	BCC, SSC	Year-round resident in open woodland, grassland, savannah and scrub. Prefers areas with sparse shrubs, trees, posts, and other suitable perches for foraging. Preys upon large insects and small vertebrates. Nests are well-concealed in densely-foliaged shrubs or trees.	<b>Unlikely.</b> Foraging habitat within the Study Area is sub optimal. Accounts of this species from Richmond et al. (2011) show the species typically nests in the eastern portions of the county where undeveloped areas more suitable for foraging are plentiful.	No further actions are recommended for this species.

SPECIES	STATUS*	HABITAT	POTENTIAL FOR OCCURRENCE**	RECOMMENDATIONS
Lewis's woodpecker <i>Melanerpes lewis</i>	BCC	Uncommon winter resident occurring on open oak savannahs, broken deciduous and coniferous habitats.	<b>Unlikely.</b> This species does not breed in the San Francisco Bay Area. The Study Area does not contain open oak woodlands and typical habitats of this species.	No further actions are recommended for this species.
Costa's hummingbird <i>Calypte costae</i>	BCC	Desert and semi-desert, arid brushy foothills and chaparral, in migration and winter also in adjacent mountains and in open meadows and gardens.	<b>No Potential.</b> Only three confirmed records exist for this species and occurred in: 1875, 1890 and 1995. The species does not breed in Alameda County.	No further actions are recommended for this species.
tricolored blackbird <i>Agelaius tricolor</i>	SE, SSC, BCC	Resident, though disperses somewhat when not breeding. Typically nests over or near freshwater in dense cattails, tules, or thickets of willow, blackberry, wild rose or other tall herbs. Highly colonial; breeding aggregations tend to be large.	<b>No Potential.</b> There is no marsh or thickets of willow to support nesting or foraging of this species.	No further actions are recommended for this species.
short-eared owl <i>Asio flammeus</i>	SSC	Resident and winter visitor, found in open, treeless areas with elevated perches and dense vegetation. Tall grasses and/or emergent vegetation are needed for nesting and daytime seclusion.	<b>No Potential.</b> The Study Area does not contain tall grasses and emergent vegetation for nesting.	No further actions are recommended for this species.

SPECIES	STATUS*	HABITAT	POTENTIAL FOR OCCURRENCE**	RECOMMENDATIONS
western yellow-billed cuckoo <i>Coccyzus americanus occidentalis</i>	FT, SE, BCC	Summer resident, breeding in dense riparian forests and jungles, typically with early successional vegetation present. Utilizes densely-foliaged deciduous trees and shrubs. Eats mostly caterpillars. Current breeding distribution within California very restricted.	<b>No Potential.</b> The species does not breed in Alameda County.	No further actions are recommended for this species.
Ridgway's (California clapper) rail <i>Rallus obsoletus (longirostris) obsoletus</i>	FE, SE, CFP	Associated with tidal salt marsh and brackish marshes supporting emergent vegetation, upland refugia, and incised tidal channels.	<b>No Potential.</b> The Study Area does not contain marsh habitat and is outside of the known breeding distribution of this species.	No further actions are recommended for this species.
California black rail <i>Laterallus jamaicensis coturniculus</i>	ST, CFP, BCC	Occurs in tidal salt marsh with dense stands of pickleweed as well as freshwater to brackish marshes.	<b>No Potential.</b> The Study Area and vicinity do not contain marsh habitat.	No further actions are recommended for this species.
western snowy plover <i>Charadrius alexandrinus nivosus</i>	FT, SSC	Federal listing applies only to the Pacific coastal population. Found on sandy beaches, salt pond levees, and shores of large alkali lakes. Requires sandy, gravelly, or friable soils for nesting.	<b>No Potential.</b> The Study Area and vicinity do not contain shore, lake, or sandy habitats to support nesting or foraging of this species.	No further actions are recommended for this species.

SPECIES	STATUS*	HABITAT	POTENTIAL FOR OCCURRENCE**	RECOMMENDATIONS
California least tern <i>Sterna antillarum browni</i>	FE, SE	Nests along the coast from San Francisco bay south to northern Baja California. Colonial breeder on bare or sparsely vegetated, flat substrates: sand beaches, alkali flats, landfills, or paved areas.	<b>No Potential.</b> The Study Area and vicinity do not contain shore, gravel, or sandy habitats to support nesting or foraging of this species. This species inhabits lands immediately adjacent to or within San Francisco Bay.	No further actions are recommended for this species.
bank swallow <i>Riparia riparia</i>	ST	Migrant in riparian and other lowland habitats in western California. Colonial nester in riparian areas with vertical cliffs and banks with fine-textured or fine-textured sandy soils near streams, rivers, lakes or the ocean.	<b>No Potential.</b> The species does not breed in Alameda County.	No further actions are recommended for this species.
black-chinned sparrow <i>Spizella atrogularis</i>	BCC	(Nesting) prefers sloping ground in mixed chaparral, chamise-redshank chaparral, sagebrush, and similar brushy habitats. Often on arid, south-facing slopes with ceanothus, manzanita, sagebrush, and chamise.	<b>No Potential.</b> This species is a rare breeder in Alameda county. When present it primarily nests in the far southeastern portions of the county (Richmond et al. 2011).	No further actions are recommended for this species.

SPECIES	STATUS*	HABITAT	POTENTIAL FOR OCCURRENCE**	RECOMMENDATIONS
yellow-breasted chat <i>Icteria virens</i>	SSC	Summer resident, occurring in riparian areas with an open canopy, very dense understory, and trees for song perches. Nests in thickets of willow, blackberry, and wild grape.	<b>Unlikely.</b> The Study Area does not provide the exceptionally dense riparian vegetation which is required for nesting by this species. This species is a very rare breeder in Alameda County.	No further actions are recommended for this species.
saltmarsh common yellowthroat <i>Geothlypis trichas sinuosa</i>	SSC, BCC	Resident of San Francisco bay region fresh and salt water marshes. Requires thick, continuous cover down to water surface for foraging, tall grasses, tule patches, willows for nesting.	<b>Unlikely.</b> The Study Area does not contain any saltmarsh or thick contiguous cover required by the species. The species does not typically nest within this portion of Alameda County.	No further actions are recommended for this species.
purple martin <i>Progne subis</i>	SSC	Summer resident. Breeds in woodlands and other relatively open habitat. Nests in cavities, usually in tall, isolated trees or man-made structures.	<b>Unlikely.</b> While habitat within the riparian areas may be able to support the species, this species is also very rare to Alameda County. Richmond et al. (2011) did not confirm any nesting activity by the species within the county.	No further actions are recommended for this species.

SPECIES	STATUS*	HABITAT	POTENTIAL FOR OCCURRENCE**	RECOMMENDATIONS
yellow warbler <i>Setophaga (Dendroica) petechia brewsteri</i>	SSC	Summer resident, nesting in riparian stands of willows, cottonwoods, aspens, sycamores, and alders. Also nests in suitable montane shrubbery.	<b>Moderate Potential.</b> Suitable stands of willows may occur within the riparian zones of the Study Area. Richmond et al (2011) and occurrences in eBird (2015) have confirmed sightings or possible nesting activity within the local area.	Work windows or pre-construction nesting bird surveys. See section 6 for additional measures.
yellow-headed blackbird <i>Xanthocephalus xanthocephalus</i>	SSC	Migrant and local summer resident. Nests colonially in freshwater emergent wetlands with dense vegetation and deep water, often along borders of lakes or larger ponds.	<b>No Potential.</b> This species is not known to breed in Alameda county.	No further actions are recommended for this species.
lesser yellowlegs <i>Tringa flavipes</i>	BCC	Breeds in open boreal forest with scattered shallow wetlands. Winters in wide variety of shallow fresh and saltwater habitats.	<b>No Potential.</b> The Study Area does not contain open fresh or saltwater habitat to support nesting by the species. This species is not known to breed in Alameda county.	No further actions are recommended for this species.
least bittern <i>Ixobrychus exilis</i>	SSC, BCC	Summer resident in portions of the Central Valley and southern California. Typically breeds in deeper freshwater marshes with dense emergent and woody vegetation.	<b>No Potential.</b> This species is not known to breed in Alameda County.	No further actions are recommended for this species.

SPECIES	STATUS*	HABITAT	POTENTIAL FOR OCCURRENCE**	RECOMMENDATIONS
Lawrence's goldfinch <i>Carduelis lawrencei</i>	BCC	Resident to nomadic; inhabits oak woodlands, chaparral, riparian woodlands and other areas, often near water. Not known to breed in the vicinity of San Francisco Bay.	<b>Unlikely.</b> This species primarily breeds in the southern portions of Alameda County where expanses of open oak woodland are present.	No further actions are recommended for this species.
Alameda song sparrow <i>Melospiza melodia pusillula</i>	BCC, SSC	Resident of salt marshes bordering south arm of San Francisco Bay. Inhabits <i>Salicornia</i> marshes; nests low in <i>Grindelia</i> bushes (high enough to escape high tides) and in <i>Salicornia</i> .	<b>No Potential.</b> The Study Area is a former naval hospital. There are no salt marshes present to support nesting by the species.	No further actions are recommended for this species.
whimbrel <i>Numerius phaeopus</i>	BCC	Breeds in various tundra habitat, from wet lowlands to dry heath. In migration, frequents various coastal and inland habitats, including fields and beaches. Winters in tidal flats and shorelines, occasionally visiting inland habitats.	<b>No Potential.</b> This species is not known to breed in Alameda county.	No further actions are recommended for this species.

SPECIES	STATUS*	HABITAT	POTENTIAL FOR OCCURRENCE**	RECOMMENDATIONS
<b>Reptiles and Amphibians</b>				
western pond turtle <i>Actinemys (Emys) marmorata</i>	SSC	Occurs in perennial ponds, lakes, rivers and streams with suitable basking habitat (mud banks, mats of floating vegetation, partially submerged logs) and submerged shelter.	<b>Unlikely.</b> Waters within the Study Area are limited to Rifle range Branch Creek which does not provide suitable basking habitat or suitable water depths to support the species. The Study Area also lacks friable soils in the uplands to support nesting by the species.	No further actions are recommended for this species.
Alameda whipsnake <i>Masticophis lateralis euryxanthus</i>	FT, ST	Inhabits chaparral and foothill-hardwood habitats in the eastern Bay Area. Prefers south-facing slopes and ravines with rock outcroppings where shrubs form a vegetative mosaic with oak trees and grasses.	<b>Unlikely.</b> The Study Area is has limited connectivity to potentially occupied habitats. Suitable scrub and woodland habitats are extremely limited within the Study Area, and protocol-level surveys have not documented the species within the Study Area to date.	No further actions are recommended for this species.



SPECIES	STATUS*	HABITAT	POTENTIAL FOR OCCURRENCE**	RECOMMENDATIONS
foothill yellow-legged frog <i>Rana boylei</i>	SSC	Found in or near rocky streams in a variety of habitats. Prefers partly-shaded, shallow streams and riffles with a rocky substrate; requires at least some cobble-sized substrate for egg-laying. Needs at least 15 weeks to attain metamorphosis. Feeds on both aquatic and terrestrial invertebrates.	<b>Unlikely.</b> The Study Area contains a small length of perennial waterway that is primarily composed of a stormwater outfall. The Study Area is also isolated from neighboring populations by urban development.	No further actions are recommended for this species.
California red-legged frog <i>Rana draytonii</i>	FT, SSC	Associated with quiet perennial to intermittent ponds, stream pools, and wetlands. Prefers shorelines with extensive vegetation. Documented to disperse through upland habitats after rains.	<b>Unlikely.</b> The Study Area contains a small length of perennial waterway that is primarily composed of a stormwater outfall. The Study Area is also isolated from neighboring populations by urban development.	No further actions are recommended for this species.
California tiger salamander <i>Ambystoma californiense</i>	FT, ST, SSC	Populations in Santa Barbara and Sonoma counties currently listed as endangered. Inhabits grassland, oak woodland, ruderal and seasonal pool habitats. Seasonal ponds and vernal pools are crucial to breeding. Adults utilize mammal burrows as estivation habitat.	<b>Unlikely.</b> The Study Area contains a small length of perennial waterway that is primarily composed of a stormwater outfall. The Study Area is also isolated from neighboring populations by urban development.	No further actions are recommended for this species.

SPECIES	STATUS*	HABITAT	POTENTIAL FOR OCCURRENCE**	RECOMMENDATIONS
<b>Fish</b>				
tidewater goby <i>Eucyclogobius newberryi</i>	FE, SSC	Brackish water habitats along the California coast from Agua Hedionda Lagoon, San Diego County to the mouth of the Smith River. Found in shallow lagoons and lower stream reaches, they need fairly still but not stagnant water and high oxygen levels.	<b>No Potential.</b> The Study Area does not contain any lagoon habitat or occur adjacent to any suitable saltwater habitat.	No further actions are recommended for this species.
Delta smelt <i>Hypomesus transpacificus</i>	FT, ST, RP	Endemic to the Sacramento-San Joaquin delta area; found in areas where salt and freshwater systems meet. It occurs seasonally in Suisun Bay, Carquinez Strait and San Pablo Bay.	<b>No Potential.</b> The Study Area does not contain any suitable brackish water habitat to support the species.	No further actions are recommended for this species.
longfin smelt <i>Spirinchus thaleichthys</i>	FCT, ST, RP	Found in open waters of estuaries, mostly in the middle or bottom of the water column. This species prefers salinities of 15 to 30 ppt, but can be found in completely freshwater to almost pure seawater.	<b>No Potential.</b> The Study Area does not contain any suitable brackish or saltwater habitat to support the species.	No further actions are recommended for this species.

SPECIES	STATUS*	HABITAT	POTENTIAL FOR OCCURRENCE**	RECOMMENDATIONS
steelhead - central CA coast ESU <i>Oncorhynchus mykiss</i>	FT	Anadromous, spending most of life cycle in the ocean. This ESU occurs from the Russian River south to Soquel Creek and Pajaro River, including the San Francisco and San Pablo Bay Basins. Adults migrate upstream to spawn in cool, clear, well-oxygenated streams. Juveniles remain in fresh water for 1 or more years before migrating downstream to the ocean.	<b>No Potential.</b> The creeks which run through the Study Area are not connected to the waters of San Francisco Bay. The absence of anadromy precludes the species from being present.	No further actions are recommended for this species.
<b>Invertebrates</b>				
vernal pool fairy shrimp <i>Branchinecta lynchi</i>	FT, SSI, RP	Endemic to the grasslands of the Central Valley, central coast mountains, and south coast mountains, in astatic rain-filled pools. Inhabits small, clear-water sandstone-depression pools and grassed swale, earth slump, or basalt-flow depression pools.	<b>No Potential.</b> The Study Area does not contain any vernal pool features that are required to support the species.	No further actions are recommended for this species.
Bay checkerspot butterfly <i>Euphydryas editha bayensis</i>	FT, SSI, RP	Restricted to native grasslands on outcrops of serpentine soil in the vicinity of San Francisco Bay. <i>Plantago erecta</i> is the primary host plant; <i>Orthocarpus densiflorus</i> and <i>O. purpurascens</i> are the secondary host plants.	<b>No Potential.</b> This species is considered extirpated from the East Bay hills (CNDDDB 2015).	No further actions are recommended for this species.

SPECIES	STATUS*	HABITAT	POTENTIAL FOR OCCURRENCE**	RECOMMENDATIONS
Callippe silverspot butterfly <i>Speyeria callippe callippe</i>	FE, SSI	Restricted to the northern coastal scrub of the San Francisco peninsula. Hostplant is <i>Viola pedunculata</i> . Most adults found on east-facing slopes; males congregate on hilltops in search of females.	<b>No Potential.</b> There are no suitable soils within the Study Area to support the host plants of the species.	No further actions are recommended for this species.
monarch butterfly <i>Danaus plexippus</i>	SSI (winter roosting areas)	Winter roost sites located in wind-protected tree groves, with nectar and water sources nearby; sites are generally on or close to the coast.	<b>No Potential.</b> The Study Area occurs inland from the coast of San Francisco Bay. Roost trees for the species are primarily located along the coast. Two occurrences of roost trees have been recorded in Alameda county by CNDDDB (2015); both are approximately 5 miles from the Study Area.	No further actions are recommended for this species.

**\* Key to status codes:**

BCC	U.S. Fish & Wildlife Service (USFWS) Birds of Conservation Concern
CFP	CDFW Fully Protected Animal
FCT	Federal Candidate Threatened
FE	Federal Endangered
FT	Federal Threatened
RP	Sensitive species included in a USFWS Recovery Plan or Draft Recovery Plan
SE	State Endangered
SCT	State Candidate Threatened
SSC	California Department of Fish and Game (CDFG) Species of Special Concern
ST	State Threatened
Rank 1A	California Native Plant Society (CNPS) Rank 1A: Plants presumed extirpated in California and rare or extinct elsewhere
Rank 1B.1	California Native Plant Society (CNPS) Rank 1B.1: Plants rare, threatened or endangered in California and elsewhere (seriously threatened in California)
Rank 1B.2	California Native Plant Society (CNPS) Rank 1B.2: Plants rare, threatened, or endangered in California and elsewhere (moderately threatened in California)
Rank 2B.2	California Native Plant Society (CNPS) Rank 2B.2: Plants rare, threatened, or endangered in California, but more common elsewhere (moderately threatened in California)
Rank 3	California Native Plant Society (CNPS) Rank 3: Plants about which more information is needed (a review list).
Rank 4.3	California Rare Plant Rank 4.3: Plants of Limited Distribution - A Watch List (not very threatened in California)
WBWG	Western Bat Working Group Priority Species
WL	CDFW Watch List

**\*\*Potential species occurrence definitions:**

Present. Species was observed on the site during site visits or has been recorded (i.e. CNDDDB, other reports) on the site recently.

High Potential. All of the habitat components meeting the species requirements are present and/or most of the habitat on or adjacent to the site is highly suitable. The species has a high probability of being found on the site.

Moderate Potential. Some of the habitat components meeting the species requirements are present, and/or only some of the habitat on or adjacent to the site is unsuitable. The species has a moderate probability of being found on the site.

Unlikely. Few of the habitat components meeting the species requirements are present, and/or the majority of habitat on and adjacent to the site is unsuitable or of very poor quality. The species has a low probability of being found on the site.

No Potential. Habitat on and adjacent to the site is clearly unsuitable for the species requirements (foraging, breeding, cover, substrate, elevation, hydrology, plant community, site history, disturbance regime).

APPENDIX C

STUDY AREA PHOTOGRAPHS



**Top:** Wetland located in the northeast corner of the Study Area. View facing west.

**Bottom:** Rifle Range Creek stormwater outfall in Study Area flowing south into Project Area.

Photographs taken January 23, 2017.



**Appendix E**  
Updated Oak Knoll Tree  
Removal Impact Mitigation  
Plan (March 2017)



---

## Memorandum

**To:** City of Oakland  
c/o Robert Zhan, Tree Supervisor II  
Giacomo Damonte, Arborist Inspector

**From:** Kari Dupler  
dupler@wra-ca.com

**Subject:** Oak Knoll Mixed Use Development Project Tree Removal Impact Mitigation Plan

**Date:** March 24, 2017

---

### Introduction

The purpose of this memorandum is to describe the proposed tree mitigation plan that has been developed to compensate for tree removal impacts associated with the proposed Oak Knoll Mixed Use Development Project (Project) in Oakland, Alameda County, California (Project Area). Oak Knoll is a Master Planned Residential Community Development Project that would develop up to 935 residential units, including a range of single-family housing types, townhomes, and multifamily units that would be developed throughout the Project Area. A Village Center would provide a variety of neighborhood-serving retail of approximately 72,000 square feet of locally serving commercial uses and the highest density housing. The Project would also create approximately 75 to 85 acres of publicly accessible open space comprising an extensive network of parks, trails, and walkways that would weave through the Project Area, connecting various neighborhoods within the Project Area with adjacent open space areas and neighborhoods.

The Project would result in the removal of approximately 4,502 trees, most of which are protected under the City of Oakland's (City's) Tree Protection Ordinance. The Project proponent (Applicant) will obtain a tree removal permit from the City prior to the removal of these trees. Additional mitigation measures proposed by the Applicant to compensate for the loss of protected trees and oak woodland are summarized below.

### Tree Impacts

WRA, Inc. (WRA) ISA-Certified Arborists, Erich Schickenberg (#WE-10211A) and Scott Yarger (#WE-9300A), conducted tree surveys throughout the months of April, May, and October 2015, and January 2017 (see WRA 2015a for detailed methodology). The tree surveys included an inventory and basic assessment of all trees within the Project Area and surrounding areas potentially impacted by the Project. All trees greater than 9 inches in diameter at breast height (DBH) were surveyed and all coast live oak (*Quercus agrifolia*) trees greater than 4 inches in DBH were surveyed, in accordance with the City of Oakland Tree Ordinance. Although eucalyptus (*Eucalyptus* spp.) and Monterey pine (*Pinus radiata*) are not protected by the City Ordinance, these species were also surveyed for a more complete analysis. Data relevant to the tree removal permitting process, including species, size (DBH), protection status, and condition rating (ranging

from poor to excellent) were collected. Each surveyed tree location was recoded using a GPS with sub-meter accuracy, and each tree was given a unique, numbered aluminum tree tag.

The survey identified 4,502 trees within the limits of disturbance (LOD) and for invasive removal, of which 3,567 are protected under the City Tree Ordinance, and 2,518 are native species (see Table 1 and Appendix A). For the purpose of this analysis it is assumed that trees located within a 10-foot buffer of the LOD would be preserved; however, a small number of these trees may be impacted depending on the extent of adjacent disturbance as well as the extent of the root zone and canopy. If additional trees are impacted, they will also be mitigated for in accordance with the City Tree Ordinance.

Project impacts are generally concentrated in previously developed, in-fill areas, and disturbed areas. The trees proposed for removal are disproportionately non-native, invasive species. In total, the Project would impact approximately 51% of the native trees within the Project Area and 84% of the non-native trees in the project area. Most of the highest quality habitats within the Project Area including the Hardenstine parcel in the southeast, the knoll in the east, and the Rifle Range Creek corridor would either be preserved or restored as part of the project. The majority of non-native trees being impacted are invasive species such as blue gum (*Eucalyptus globulus*), Monterey pine, and blackwood acacia (*Acacia melanoxylon*) which have colonized portions of the site and have converted native grasslands and oak woodlands to invasive-dominated woodlands. As such, the removal of invasive trees and, in some cases, conversion to native oak woodlands is expected to result in improved habitat quality for native plants and wildlife over time.

Of the native trees proposed for removal, 817 (32%) are less than 9 inches in DBH and 460 (19%) are currently in poor condition, defined as being in moderate to severe decline (see Tables 2 and 3). The remaining native trees are greater than 9 inches in DBH and are in fair to excellent condition.

**Table 1.** Summary of Trees within the Limits of Disturbance, 10-Foot Disturbance Buffer, and Preserved Areas.

Species	Limits of Disturbance	Location			Total
		10-ft buffer	Invasive Removal	Preserved Area	
<b>Native</b>	<b>2,518</b>	<b>149</b>	<b>-</b>	<b>2,280</b>	<b>4,947</b>
<i>Quercus agrifolia</i> <sup>1</sup>	2,298	140	-	2,064	4,502
<i>Umbellularia californica</i> <sup>1</sup>	55	6	-	168	229
<i>Salix laevigata</i> <sup>1</sup>	53	-	-	3	56
<i>Salix lasiolepis</i> <sup>1</sup>	37	2	-	3	42
Other <sup>1</sup>	75	1	-	42	118
<b>Non-native</b>	<b>1,629</b>	<b>73</b>	<b>355</b>	<b>319</b>	<b>2,376</b>
<i>Eucalyptus globulus</i> <sup>2,3</sup>	325	48	172	146	691
<i>Acacia melanoxylon</i> <sup>3</sup>	296	5	18	48	367
<i>Pinus radiata</i> <sup>2</sup>	124	-	100	29	253
<i>Cedrus deodara</i>	159	6	-	5	170
<i>Eucalyptus camaldulensis</i> <sup>2,3</sup>	100	1	37	1	139
<i>Acacia baileyana</i>	55	5	1	4	65
<i>Quercus ilex</i>	55	-	-	15	70
<i>Pinus ponderosa</i>	27	3	2	20	52
<i>Eucalyptus sideroxylon</i>	52	-	-	-	52
<i>Acacia longifolia</i>	25	2	1	15	43
Other (protected)	387	3	23	36	449
Other (non-protected)	24	3	1	-	28
<b>Total</b>	<b>4,147</b>	<b>222</b>	<b>355</b>	<b>2,599</b>	<b>7,323</b>

<sup>1</sup>Require mitigation under the City of Oakland Tree Ordinance.

<sup>2</sup>Not protected under City of Oakland Tree Ordinance.

<sup>3</sup>Listed is invasive by the California Invasive Plant Council.

**Table 2.** Summary of Impacted Native Trees by Size Class

Species	Size Class				Total
	4.0-8.9	9.0-17.9	18.0-35.9	>36.0	
<b>Native</b>					
<i>Quercus agrifolia</i>	817	921	595	185	2,518
<i>Umbellularia californica</i>	-	40	14	1	55
<i>Salix laevigata</i>	-	15	14	1	53
<i>Salix lasiolepis</i>	-	12	16	9	37
<i>Alnus rhombifolia</i>	-	16	7	2	25
<i>Sequoia sempervirens</i>	-	2	7	2	11
<i>Sambucus nigra</i> ssp. <i>caerulea</i>	-	5	4	1	10
<i>Prunus ilicifolia</i>	-	6	4	-	10
<i>Aesculus californica</i>	-	4	5	-	9
<i>Arbutus menziesii</i>	-	1	4	-	5
<i>Platanus racemosa</i>	-	3	1	-	4
<i>Heteromeles arbutifolia</i>	-	1	-	-	1
<b>Total</b>	<b>817</b>	<b>921</b>	<b>595</b>	<b>185</b>	<b>2,518</b>

**Table 3.** Summary of Impacted Native Trees by Condition

Species	Condition Rating				Total
	Poor	Fair	Good	Excellent	
<b>Native</b>					
<i>Quercus agrifolia</i>	387	1,223	638	50	2,298
<i>Umbellularia californica</i>	5	14	33	3	55
<i>Salix laevigata</i>	29	17	6	1	53
<i>Salix lasiolepis</i>	22	13	2	-	37
<i>Alnus rhombifolia</i>	10	12	3	-	25
<i>Sequoia sempervirens</i>	-	4	2	5	11
<i>Sambucus nigra</i> ssp. <i>caerulea</i>	4	4	2	-	10
<i>Prunus ilicifolia</i>	4	3	2	1	10
<i>Aesculus californica</i>	3	5	1	-	9
<i>Arbutus menziesii</i>	1	1	-	3	5
<i>Platanus racemosa</i>	1	1	2	-	4
<i>Heteromeles arbutifolia</i>	1	-	-	-	1
<b>Total</b>	<b>467</b>	<b>1,297</b>	<b>691</b>	<b>63</b>	<b>2,518</b>

## Proposed Mitigation Plan

### *Mitigation Requirements per the City of Oakland Tree Ordinance*

The City of Oakland Tree Protection Ordinance requires replacement plantings to mitigate for the loss of functions provided by protected trees including shade, erosion control, groundwater replenishment, visual screening, and wildlife habitat. Preliminary mitigation criteria have been agreed upon in consultation with the City during a pre-application design conference and subsequent correspondence between the City and the Applicant. Preliminary mitigation criteria are as follows:

1. Mitigation in the form of replacement trees is only required for native, protected trees. Replacement planting is not required for non-native protected trees (*i.e.*, any non-native species 9 inches DBH or greater, excluding eucalyptus species and Monterey pine).
2. Any native replacement tree will count towards mitigation for native protected tree removal.
3. Mitigation credits for replacement trees will be calculated at the following ratios (replacement trees to removed trees), with larger sized replacement trees receiving greater mitigation credit:
  - 5:1 for 5-gallon pot size;
  - 3:1 for 15-gallon pot size;
  - 1:1 for 24-inch box size;
  - 1:1.5 for 36-inch box
  - 1:2 for 48-inch box
  - 1:3 for 60-inch box.

Details of the proposed tree replacement plan are described below.

### *Conceptual Tree Replacement Plan*

The proposed tree replacement/mitigation plan designed by Hart Howerton, Ltd. and WRA, Inc. entails replanting more than 8,500 native trees across more than 40 acres of the Project Area to compensate for the removal of 2,518 protected trees, for a greater than 4:1 overall mitigation ratio. The proposed mitigation planting palette, tree counts, and conceptual plan are shown on the preliminary tree mitigation map (Hart Howerton 2015; Appendix B). Replacement tree species include more than 10 native tree species, all of which are found to occur naturally within the vicinity of the Project Area. As described above, the Project Area contains significant stands of non-native invasive species, particularly blue gum, Monterey pine, and blackwood acacia. In addition to the tree impacts associated with grading, the Project proposes to remove several hundred non-native, invasive, and fire-prone tree species from several preserved areas with the Project Area. These invasive tree removal areas would then be restored and re-planted with native tree species. This restoration would ultimately improve habitat quality for native species and reduce the risk of fire.

The preliminary tree mitigation map (Appendix B) includes four conceptual planting areas: open space/woodland slope areas, street tree planting areas, community center, and in-tract areas. In addition, the mitigation areas would include a proposed riparian planting palette in accordance with the proposed Rifle Range Creek Riparian Restoration Plan (WRA 2015b). Replacement trees sizes will vary from five-gallon pot size up to 60-inch box trees, with most replacement trees

being 15-gallon pot size. Proposed spacing for replacement trees will range from grouped plantings 10 to 14 feet on center per 700 square feet for small 5- to 15-gallon pot sizes, to 23 to 26 feet on center for larger box trees. The final spacing of replacement trees will be determined in consultation with the City Arborist and will be dependent on available space, slope, aspect and soil conditions.

### *Mature Tree Transplantation*

In addition to planting replacement trees from local nursery stock, the Project proposes to save and transplant mature, healthy, native trees from within the proposed LOD where feasible. The Project Applicant is currently assessing the feasibility of transplanting indigenous coast live oak trees from within the proposed LOD to the proposed mitigation areas. Transplanting mature, healthy coast live oak trees, indigenous to the Project Area, instead of removing and replacing with nursery stock would help to reduce the number of trees impacted by removal and would preserve healthy, locally adapted specimens, that in many cases are larger than any commercially available replacement trees.

Potential candidates for transplantation and preservation within the proposed mitigation area are currently being assessed based on the following criteria:

1. The tree is a native coast live oak within the proposed impact area/LOD.
2. The tree is in moderate to excellent condition, exhibiting no significant defect or health issue.
3. The tree is generally open-grown, and exhibits good form typical of the species. The tree is located on a negligible to mild slope, as trees growing in this topography typically develop stable root systems amenable to transplantation.

Although trees growing within closed canopy environments and on steep slopes may often be healthy and in good condition, these trees are often poor candidates for transplanting, as they are adapted to growing in closed canopy environments and will not fare well when transplanted into a new environment. Following the criteria listed above, it is estimated that up to 20 indigenous coast live oak trees will be potentially transplanted into the proposed mitigation area.

In addition to transplanting potentially impacted native coast live oak trees, the Project Applicant is also assessing the feasibility of transplanting potentially impacted mature, healthy, non-native ornamental trees such as holly oak (*Quercus ilex*), and Deodar cedar (*Cedrus deodara*). As per the Ordinance described above, mitigation is not required for removal of non-native species; however, the Project Applicant is interested in reducing overall tree removal impacts where feasible, and transplanting trees off-site where feasible. Potential candidates for transplantation off-site are currently being assessed based on criteria 2 and 3 outlined above, except that these trees will be desirable non-invasive, ornamental species such as holly oak and Deodar cedar. Non-native, invasive species such as eucalyptus and acacia will not be considered for transplantation. Potential off-site transplantation could include privately-owned land owners purchasing trees for use on private landscapes and/or donation of trees to the City for use on public lands such as City-owned parks.

## **Additional Considerations and Recommendations**

### *Fire Prevention and Defensible Space Requirements*

Fire prevention and defensible space requirements are important considerations in regards to the conceptual tree mitigation/replanting plan. The California Department of Forestry and Fire Protection (CAL FIRE) has identified the Project Area as a Very High Fire Hazard Severity Zone (VHFHSZ) based on data and models of potential fuels and their expected fire behavior (CAL FIRE 2008). Within areas designated as VHFHSZs, California Building Codes require that hazardous vegetation and fuels be managed to reduce the severity of potential for wildfire. Homeowners are required to maintain defensible fuel space, or areas of reduced vegetation intended to reduce the potential for wildfire to spread, within 100 feet of occupied structures.

To comply with defensible fuel space requirements, mitigation areas located within 100 feet of proposed structures would be maintained with a sparse understory and well-pruned, well-spaced trees.

### *Sudden Oak Death Prevention*

Preventing the potential spread of *Phytophthora ramorum*, the pathogen that causes sudden oak death (SOD), is another factor considered in the conceptual tree mitigation/replanting plan. Verified occurrences of SOD occur in the vicinity of the Project Area (Kelly and Tuxen 2003; Kelley et al. 2004). Laboratory testing of plant material is required for confirmation of the pathogen, and although this was not done, the presence of the disease within the Project Area is assumed based on the proximity of the nearest verified occurrence and observations of symptoms of the disease on susceptible species within the Project Area. Coast live oak is one of the primary true oak (*Quercus*) species killed by SOD, and within coast live oak woodland, California bay foliage is the primary vector of the pathogen (Swiecki and Bernhardt 2013). California bay is deliberately omitted from the replanting plant list due its role in spreading SOD. Additional measures recommended to prevent the spread of SOD during tree removal and replanting activities are described below.

Before working:

- Provide crews with sanitations kits. (Sanitation kits should contain the following: Chlorine bleach [10/90 mixture bleach to water], or Clorox Clean-up®, scrub-brush, metal scraper, boot brush, and plastic gloves).
- Ensure that work crews have properly cleaned and sanitized pruning gear, trucks, and chippers prior to entering the Project Area.
- Clean and sanitize shoes, pruning gear and other equipment before working in an area with susceptible species
- Susceptible species present within the Project Area include: coast live oak, canyon live oak, and California bay.

While working:

- When possible, conduct all tree work on *P. ramorum*-infected and susceptible species during the dry season (June - October). The pathogen is most likely to spread during

periods of high rainfall especially in spring (April and May). Working during wet conditions should be avoided.

- If working in wet conditions cannot be avoided, keep equipment on paved or dry surfaces and avoid mud.
- Work in disease-free areas before proceeding to suspected-infestation areas.
- All debris from California bay trees, the primary vector of the pathogen, shall be mulched and spread in place, moved to a sunny dry area free of coast live oak, or disposed of off-site in a permitted disposal facility in accordance with state and federal regulations.
- When removing California bay trees, all mulch and debris shall be segregated from other species when chipping, and all pruning gear and equipment, including chippers and trucks shall be cleaned and sanitized before working on coast live oaks.

After working:

- Use all reasonable methods to clean and sanitize personal gear and crew equipment before leaving a *P. ramorum*-infested site. Scrape, brush and/or hose off accumulated soil and mud from clothing, gloves, boots and shoes. Remove mud and plant debris, especially California bay, by blowing it out or power washing chipper trucks, chippers, buckets trucks, fertilization and soil aeration equipment, cranes, and other vehicles.
- Restrict the movement of soil and leaf litter under California bay trees as spores are most abundant on California bay leaves. Contaminated soil, particularly mud, and plant debris on vehicle tires, workers boots, shovels, chippers, stump grinders, trenchers, etc., may result in pathogen spread if moved to a new, uninfested site. Thoroughly clean all equipment and remove or wash off soil, mud, and plant debris from these items before use at another site. If complete on-site sanitation is not possible, complete the work at a local power wash facility.
- Tools used in tree removal/pruning may become contaminated and should be cleaned thoroughly with a scrub brush and disinfected with Lysol® spray, a 70% or greater solution of alcohol, or a Clorox® solution (1 part Clorox® to 9 parts water or Clorox Clean-up®).

When planting:

- Replanting should occur in the early fall when the pathogen is less active, and in order to take advantage of seasonal rains. Replanting activities should avoid late winter and spring.
- Planting sites for susceptible species including coast live oak and canyon live oak should be selected in areas that are at least 20 yards away from California bay trees, brush and/or plant material.
- California bay shall not be used as mulch for new plantings.
- Small, non-protected (less than 9 inches diameter) California bay trees and brush should be cleared within a 20-yard or greater buffer where feasible to protect susceptible oak trees that are selected for preservation.



## Conclusions

The Project would remove approximately 2,518 native trees and 1,984 non-native trees from within the Project Area. As mitigation, the Project would plant more than 8,500 native trees across more than 40 acres of the Project Area. In addition, the project would preserve 2,280 native trees and would restore the entire Rifle Range Creek corridor as well as several native oak woodland areas. Overall, the project would result in a net increase in the number of trees and acres of woodland currently present within the Project Area, including a substantial net increase in the number of native trees and native oak woodland areas (Table 4).

**Table 4.** Summary of Proposed Changes in Tree Counts and Woodland Acreages as a Result of the Project

Metric	Existing	Proposed	Approximate Change
Number of Trees	7,323	~10,818	+3,495 (+48%)
Native Trees	4,947	~8,500	+1,753 (+72%)
Non-native Trees	2,376	~500	-1,876 (-79%)
Acres of Oak Woodland	28.9	~42.5	+13.6 (+47%)
Acres of Riparian Woodland	7.3	~16.0	+8.7 (+119%)

## References

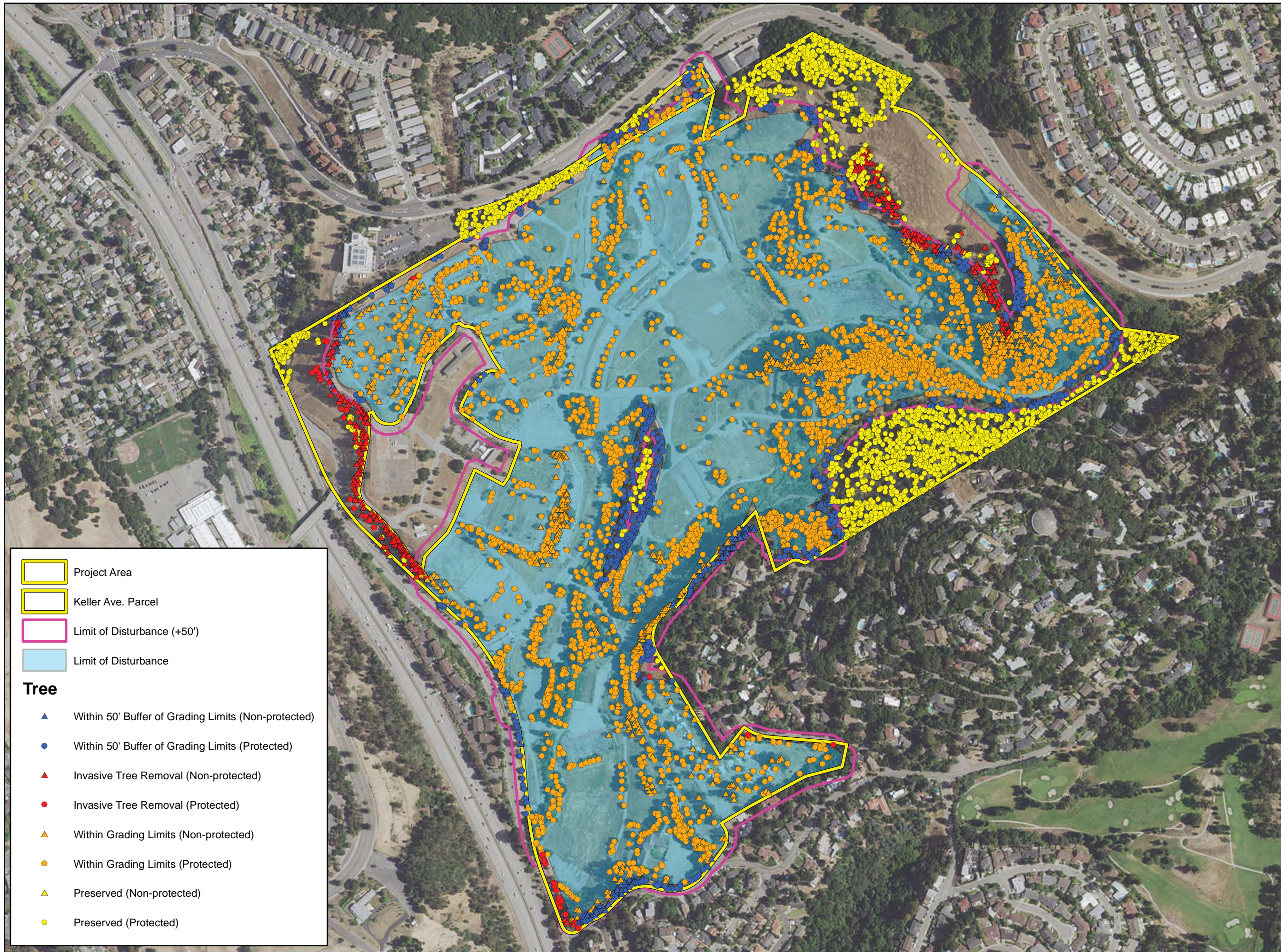
- California Department of Forestry and Fire Protection (CAL Fire). 2008. Very High Fire Hazard Severity Zones in LRA as Recommended by CAL Fire. CAL Fire-FRAP, PO Box 944246, Sacramento, California. Available online at <http://frap.cdf.ca.gov>. Accessed November 2015.
- Kelly, NM, and K Tuxen. 2003. WebGIS for sudden oak in coastal California. *Computers, Environment and Urban Systems* 27(5): 527-547
- Kelly, M, KA Tuxen, and FR Kearns. 2004. Geospatial informatics for management of a new forest disease: Sudden Oak Death. *Photogrammetric Engineering and Remote Sensing* 70(9): 1001-1004.
- Swiecki, T. J. and E. A. Bernhardt. 2013. A reference manual for managing sudden oak death in California. Gen. Tech. Rep. PSW-GTR-242. Albany, California: U.S. Department of Agriculture, Forest Service, Pacific Southwest Research Station. 129 p.
- WRA, Inc. 2015a. Rifle Range Creek Riparian Restoration Plan. 24 pp.
- WRA, Inc. 2015b. Tree Survey Report for the Oak Knoll Project. 8 pp.













**APPENDIX A. TREE REMOVAL PLAN**

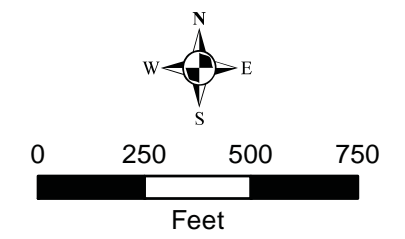
Oak Knoll Mixed Use  
Community  
Development Project

Alameda County,  
California

Tree Removal Plan

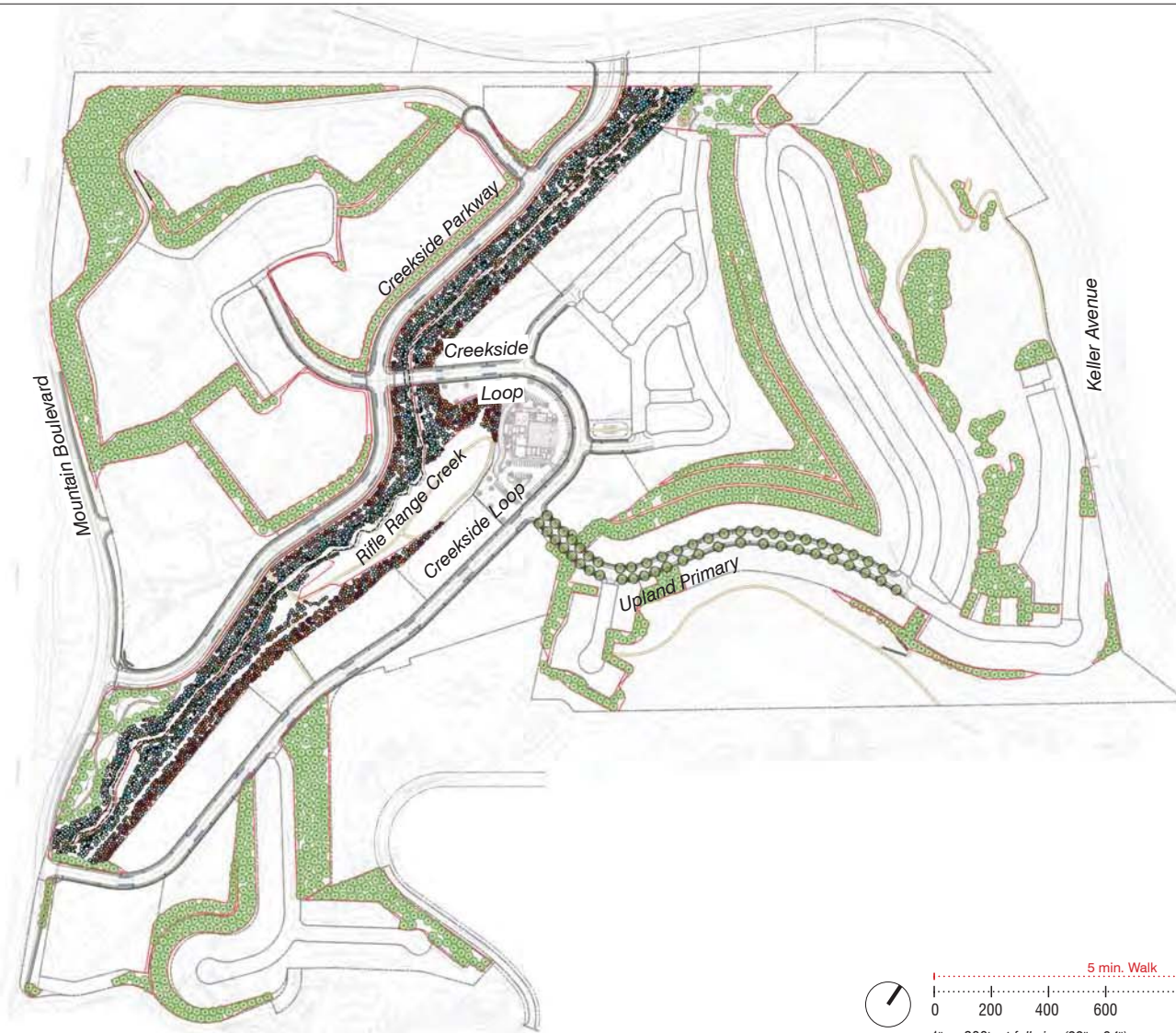


-  Project Area
  -  Keller Ave. Parcel
  -  Limit of Disturbance (+50')
  -  Limit of Disturbance
- Tree**
-  Within 50' Buffer of Grading Limits (Non-protected)
  -  Within 50' Buffer of Grading Limits (Protected)
  -  Invasive Tree Removal (Non-protected)
  -  Invasive Tree Removal (Protected)
  -  Within Grading Limits (Non-protected)
  -  Within Grading Limits (Protected)
  -  Preserved (Non-protected)
  -  Preserved (Protected)



Map Prepared Date: 1/31/2017  
Map Prepared By: czumwalt  
Base Source: USGS EROS  
Data Source(s): WRA

**APPENDIX B. CONCEPTUAL MITIGATION PLAN**



Notes:

1. Each symbol shown by ● represents either one (1) 24" box native tree, or three (3) 15 gallon native trees, or five (5) 5 gallon native trees. For open space planting within the creek corridor, see creek restoration plans (sheets L043-L045).

2. Final tree locations and quantities will in final Tree Permit and Creek Restoration Permit packages.



OPEN SPACE AND PARK AREAS			
BOTANICAL NAME	COMMON NAME	SIZE	QUANTITY
<i>QUERCUS AGRIFOLIA</i>	COAST LIVE OAK	24" BOX	550
<i>QUERCUS AGRIFOLIA</i>	COAST LIVE OAK	15 GAL.	1500
<i>QUERCUS AGRIFOLIA</i>	COAST LIVE OAK	5 GALLON	330
<i>QUERCUS WISLIZENI</i>	INTERIOR LIVE OAK	15 GALLON	50
<i>QUERCUS CHRYSOLEPIS</i>	CANYON LIVE OAK	15 GALLON	150
<i>HETEROMELES ARBUTIFOLIA</i>	TOYON	15 GALLON	312
<i>HETEROMELES ARBUTIFOLIA</i>	TOYON	5 GALLON	165
<i>AESCULUS CALIFORNICA</i>	CALIFORNIA BUCKEYE	15 GALLON	470
<i>AESCULUS CALIFORNICA</i>	CALIFORNIA BUCKEYE	5 GALLON	180
<i>GARRYA</i>	SILKTASSEL	15 GALLON	189
<i>GARRYA</i>	SILKTASSEL	5 GALLON	180
<i>ARBUTUS MENZIESSII</i>	MADRONE	5 GALLON	50
<b>TOTAL</b>			<b>4,126</b>

STREET TREES			
BOTANICAL NAME	COMMON NAME	SIZE	QUANTITY
<i>QUERCUS AGRIFOLIA</i> (UPLAND PRIMARY)	COAST LIVE OAK	36" BOX	52

COMMUNITY CENTER TREES			
BOTANICAL NAME	COMMON NAME	SIZE	QUANTITY
<i>QUERCUS LOBATA</i>	VALLEY OAK	48" BOX	6
<i>QUERCUS AGRIFOLIA</i>	COAST LIVE OAK	48" BOX	12
<i>SEQUOIA SEMPRVIRENS</i>	COAST REDWOOD	48" BOX	18

CREEK RESTORATION TREES			
BOTANICAL NAME	COMMON NAME	SIZE	QUANTITY
<i>ALNUS RHOMBIFOLIA</i>	WHITE ALDER	1 GAL.	187
<i>AESCULUS CALIFORNICA</i>	CALIFORNIA BUCKEYE	16" DEEPOT	432
		5 GAL	175
<i>ARBUTUS MENZIESSII</i>	MADRONE	5 GAL	172
<i>GARRYA ELLIPTICA</i>	COAST SILK TASSEL	5 GAL	240
<i>HETEROMELES ARBUTIFOLIA</i>	TOYON	1 GAL	161
		5 GAL	204
<i>QUERCUS AGRIFOLIA</i>	COAST LIVE OAK	16" DEEPOT	400
		5 GAL	226
<i>QUERCUS CHRYSOLEPIS</i>	CANYON LIVE OAK	5 GAL	151
<i>QUERCUS WISLIZENII</i>	INTERIOR LIVE OAK	5 GAL	156
<i>SALIX LAEVIGATA</i>	RED WILLOW	16" DEEPOT	192
<i>SALIX LASIOLEPIS</i>	ARROYO WILLOW	16" DEEPOT	166
<i>SAMBUCUS NIGRA SSP. CAERULA</i>	BLUE ELDERBERRY	16" DEEPOT	219
<i>UMBELLULARIA CALIFORNICA</i>	CALIFORNIA BAY LAUREL	1 GAL TREEPOT	131
<i>POLE CUTTINGS</i>	WILLOW, ALDER & DOG-	POLE CUTTINGS	1101
70% <i>SALIX SPP.</i>	WILLOW		
20% <i>ALNUS RHOMBIFOLIA</i>	WHITE ALDER		
10% <i>CORNUS GLABRATA</i>	BROWN DOGWOOD		
<b>TOTAL</b>			<b>4,313</b>
<b>SITE TOTAL</b>			<b>8,527</b>

Note: Final tree quantities for mitigation and open space planting in Tree Permit and Creek Restoration Permit Packages.

# **Appendix F**

## Updated Oak Knoll Design Guidelines (January 2017)



# OAK KNOLL

## Design Guidelines

January 27, 2017



## CLIENT

**Oak Knoll Venture Acquisitions LLC**

c/o Suncal  
2392 Morse Avenue  
Irvine, CA 92614

## CONSULTANT TEAM

**Hart Howerton**

1 Union Street, 3rd Floor  
San Francisco, CA 94111

Contact: Chris Hall

**Land Use Attorney**

**Cox, Castle and Nicholson**

50 California St, Suite 3200  
San Francisco, CA 94111

Contact: Linda Klein

**Civil Engineer**

**BKF Engineers**

300 Frank Ogawa Plaza  
Oakland, CA 94612

Contact: Jacob Nguyen

fix

# CONTENTS

## 1.0 INTRODUCTION

- 1.1 Community Vision .....7
- 1.2 How to use these Guidelines.....9

## 2.0 PLANNING GUIDELINES

- 2.1 Oak Knoll Neighborhoods.....13
- 2.2 Neighborhood Streetscapes .....14
- 2.3 Commercial Development Standards.....18
- 2.4 Townhome Development Standards.....22
- 2.6 Building massing and Placement.....22
- 2.5 Driveways and Garage Placement.....25

## 3.0 ARCHITECTURAL GUIDELINES

- 3.1 The Bay Area Regional Style .....27
- 3.2 The Architectural Style Matrix .....30
- 3.3 Massing - Primary Volumes.....32
- 3.4 Roofs.....33
- 3.5 High Visibility Facades.....39
- 3.6 Openings - Windows .....40
- 3.7 Exterior Doors.....42
- 3.8 Porches and Stoops .....42
- 3.9 Garages .....47
- 3.10 Lighting.....48

## 4.0 LANDSCAPE GUIDELINES

- 4.1 Landscape Vision.....51
- 4.2 Streetscape Design.....52
- 4.3 Open Space Design .....58
- 4.4 Parks and Plaza Design.....60

- 4.5 Community Trails and Recreation.....62
- 4.6 Signage and Monumentation .....64
- 4.7 Walls .....66
- 4.8 Residential Landscape Design .....67
- 4.9 Single Family Residential .....68
- 4.11 Side and Rear Yard Fencing.....71
- 4.12 Retaining Walls on Lots .....72

## APPENDICES

- Appendix A - Approved Materials and Color Palette.....i
- Appendix B - Approved Wall, Fences & Guardrails.....vi
- Appendix C - Approved Plant List.....ix



# 1.0 INTRODUCTION





View looking east from new bridge over Rifle Range Creek

## 1.1 COMMUNITY VISION

The Community at Oak Knoll is planned as a walkable system of neighborhoods anchored by a community scale retail village, neighborhood parks, and natural and accessible open space. The neighborhoods are woven together through an extensive system of trails and carefully designed streets. The primary landscape feature around which the land plan is shaped is the restored branch of the Rifle Range Creek and the surrounding upland areas to the north, south and east of the creek.

The local climate at Oak Knoll is characterized by temperate weather and is considered one of California's finest for habitation as well as horticulture. Because of this, the masterplan and residences are organized around the outdoors and integration with the landscape. In addition to the architectural features of the homes that provide links to the outdoors (porches, stoops, verandas, courtyards, decks, etc.), the abundance of trees and plants produces a vibrant natural setting.

Integrated into this landscape and streetscape vision, the residential neighborhoods will have a diverse mix of residential sizes and types and are planned to be executed in a range of architectural styles appropriate to the setting.



Retail Village



Community Open Space and Trails



OAK KNOLL DESIGN GUIDELINES | JANUARY 2017

Figure 1.1- Illustrative Master Plan

## 1.2 HOW TO USE THESE GUIDELINES

These Design Guidelines provide design principles to future builder/ applicants. Final Development Plans shall be substantially consistent with the Preliminary Development Plan. The Design Guidelines refine and clarify the direction in the Planned Unit Development and Preliminary Development Plan.

Where the Design Guidelines are silent or vague, the Preliminary Development Plan shall be used for the purposes of interpretation, and/or directly applied as appropriate.

This book is divided into three chapters: Planning, Architecture and Landscape, each of which addresses topics critical to achieving the community vision. The appendices to this book include materials, color, and plant palettes. Final Development Plans will be reviewed for their consistency with the principles and regulations set forth in these three chapters. Below is an outline of the content of each chapter:

### PLANNING

The Planning chapter addresses the selection of an appropriate plan type, the placement of the building on the lot, driveway and garage design, and building façade regulations as they relate to general neighborhood planning principles.

### ARCHITECTURE

The Architecture chapter introduces the principles of Oak Knoll architecture and how they are applied in the detailed design of a home or building. This includes the massing, roof forms, components, details, and finishes of all vertical improvements.

### LANDSCAPE

The Landscape chapter addresses landscape elements within community streetscapes, community open spaces and residential lots. This includes fences and site walls, , planting requirements, plant lists and signage regulations.



Oak Knoll Community



Typical Residential Neighborhood

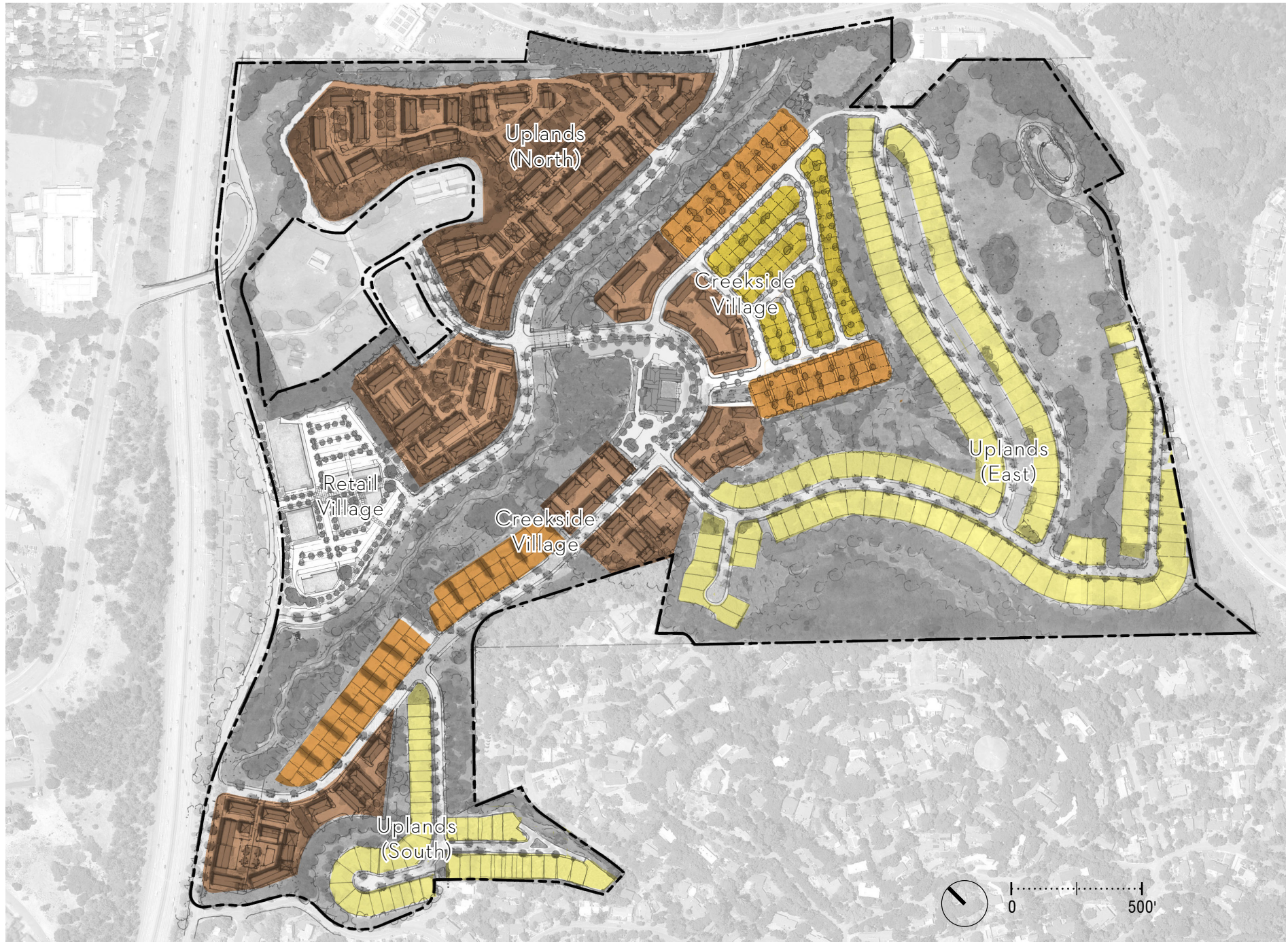




Hillside Residential

## 2.0 PLANNING GUIDELINES





OAK KNOLL DESIGN GUIDELINES | JANUARY 2017

Figure 1.2- Neighborhoods Plan

## 2.1 OAK KNOLL NEIGHBORHOODS

The site at Oak Knoll features three upland areas surrounding a lowland valley with a creek running through it. The neighborhoods that make up this community are defined as the Retail Village, Creekside Village, and the Uplands. See Figure 1.2 Neighborhoods Plan on the facing page.

### RETAIL VILLAGE

The Retail Village area is designed as a modestly-sized gathering spot to provide basic needs to the community (such as groceries, restaurants, banking). It is envisioned as a cluster of buildings at varying scales fronting a 'Principal Drive' and a 'Plaza'. It will feature landscape and street furnishings that give it a distinct identity similar to other neighborhood centers in the Oakland hills.

### CREEKSIDE VILLAGE

The Creekside Village neighborhoods are medium density residential areas laid out in the lowland areas flanking the restored Rifle Range Creek corridor. These neighborhoods are compact and walkable and feature a framework of parks and open space which connect to the creek. The Creekside Village will offer a range of residential product types from townhomes to single family detached residences as well as the relocated and refurbished Club Knoll at its center. Club Knoll will serve as a 'community center' gathering spot.

### THE UPLANDS

Residential development in the Uplands is designed to maximize views as well as provide a pleasing appearance as viewed from adjacent areas. The Uplands neighborhoods offer a range of residential product types from townhomes to single family detached residences. The Uplands connect to the surrounding community via a system of trails and preserved open space.



Retail Village - Main Street and Plaza



Club Knoll- Community Center

## 2.2 NEIGHBORHOOD STREETSCAPES

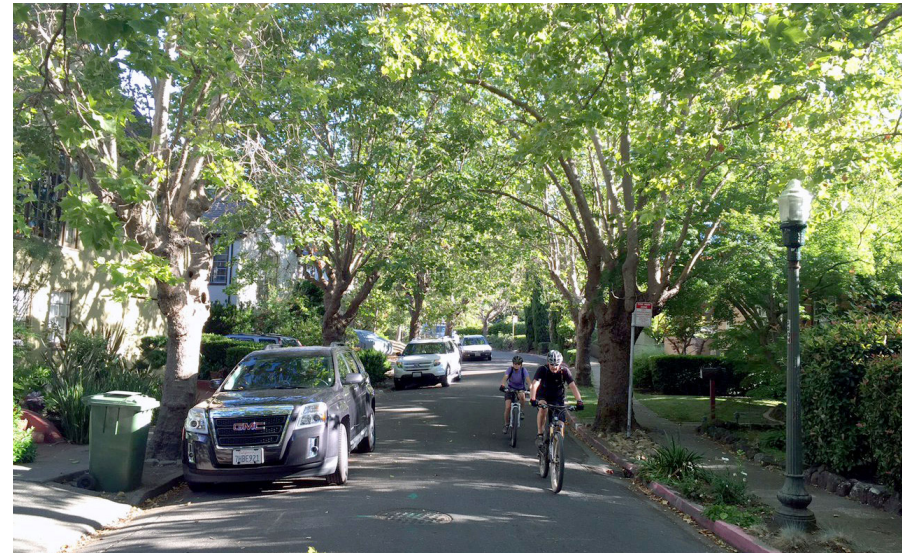
The Oak Knoll neighborhood streets are designed to be pedestrian friendly in both function and appearance. A line of street trees flanks either side of the street, with a generous sidewalk. Planting and fences in the front yard zone between the sidewalk and the homes is designed to define an appropriate transition to the semi-private yard and porch zone. Porches will be designed as outdoor rooms and lighted to provide a sense of security to the pedestrian. Please refer to the Landscape Chapter of these Design Guidelines for specific proposed street sections.



Typical Neighborhood Streetscape



Integrated Stormwater Treatment - "Rain Gardens"



Street Trees

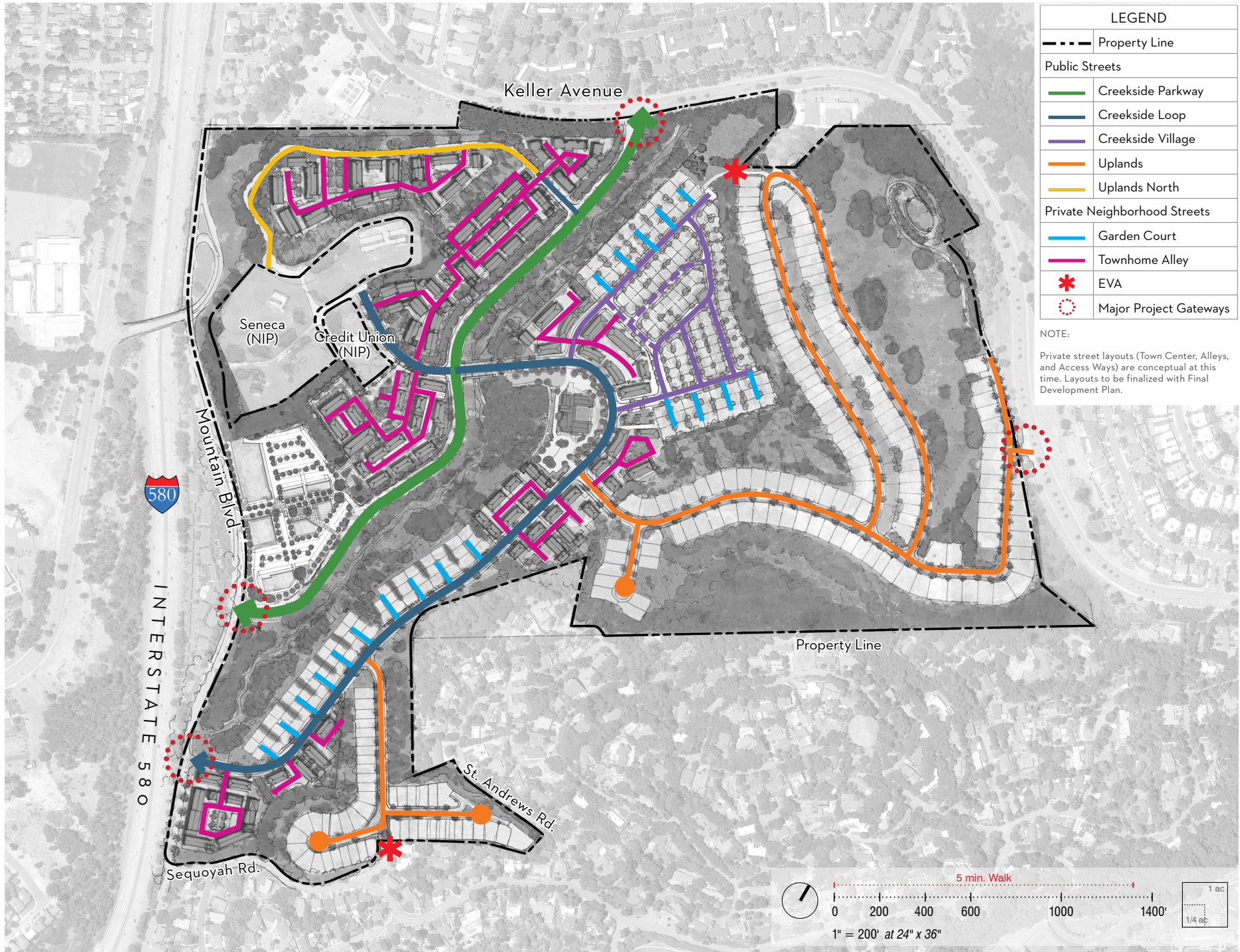


Figure 1.3- Circulation Plan

## HIGH VISIBILITY FACADES - STREET FACING

All facades which are visible from the street, including setback garages and all sections of side facing façades which are in front of garages must follow High Visibility standards as defined in the Architectural Guidelines of this book.

## HIGH VISIBILITY FACADES -OPEN SPACE FACING

The intention for an open space facing home is to present a pleasing appearance towards the open space and to take advantage of views towards the surrounding creek or woodland areas. These facades must follow High Visibility standards as well.

## ARCHITECTURAL DIVERSITY AND ‘THE MONOTONY CODE’

The purpose of the Monotony Code is to create variation and hierarchy within the Oak Knoll streetscape, giving the community an appearance of growth over time. This can be done by designing a range of home layouts and sizes that respond to the location of the lot within the overall neighborhood. The Monotony Code will be enforced through the use of a matrix tracking the following:

For each single-family detached lot type, there must be a minimum of three unique floor plan types, with three façade variations each;

- A different porch or stoop type will be considered a façade variation;
- No two detached homes of the same design may be repeated within two adjacent lots on a given Block Face or a facing Block Face;
- Homes on corner lots are encouraged to have architectural features such as wrapped porches, side porches, or bay windows facing the secondary street.
- Both the front as well as side facing facade on corner lots will be considered High Visibility Facades.



The Monotony Code aims to produce neighborhoods that have diverse streetscapes and architectural features like the images on the facing page.

The Monotony Code aims to prevent uniform streetscapes and architecture like the image to the left.



Typical Streetscapes - Creekside Village



Typical Streetscapes - Uplands



Typical Streetscapes - Uplands



## 2.3 COMMERCIAL

The Retail Village at Oak Knoll will provide public gathering spots and convenience shopping for local residents. It is envisioned as urban in character similar to other local neighborhood commercial corridors (such as sections of Park Boulevard or Lakeshore Avenue) and shall feature retail facades on the Principal Drive. The following guidelines will apply to the Retail Village:

### Design Objectives:

- Building placement that reinforces the concept of the Plaza and orients service areas away from the Plaza while keeping them screened from view from Mountain Blvd.
- 70% glazing on facades directly fronting the plaza and 50% glazing on facades fronting pedestrian pathways
- Awnings and trellis overhead canopies to provide outdoor shade and shaded gathering areas
- Sidewalk widths at primary retail facades sufficient to provide tree planting, signage, furnishings, lighting and outdoor seating areas where appropriate to adjacent retail use
- Hardscape and Planting that reinforces the outdoor pedestrian realm, but provides equal access to vehicular traffic

A final design for the retail village will be submitted by a retail developer. Retail signage locations and design shall be reviewed at the Final Development Plan submittal stage, and a Signage Master Plan will be submitted as part of that application.



Retail Village



Retail facade treatment example

## RETAIL PLAZA

The Retail Village shall be designed around a centrally-located plaza. The plaza should be located at the intersection of the two primary vehicular circulation paths: one that connects Mountain Blvd and the proposed Creekside Pkwy; and one that circulates vehicles around the perimeter of the site. The plaza should be centrally located to establish the image for the project, and serve as the gathering area flanked on all sides by retail uses.

The Principal Drive section adjacent the plaza should be designed so that it may be closed off to allow for neighborhood activities such as weekend markets and street fairs. The perimeter route will continue to provide vehicular access to the surrounding retail shops and parking.

Buildings directly fronting the plaza shall orient towards the plaza. All other buildings shall orient towards the nearest primary pedestrian path.

## ARCHITECTURAL AND LANDSCAPE CHARACTER

The Character of the Retail village should be inspired by the open-air neighborhood shopping districts typical to the Bay Area. These districts are typified by simple facades with ample glazing, clerestory windows, awnings and shade structures. Recommended materials, colors and plant palettes are similar to the residential guidelines and are contained in Appendix A. The photo references on the following two pages show the features showing appropriate character for the retail buildings.



Figure 1.6- Facade Treatments, Architectural Elements, Example of Conceptual Layout, this example plan intended to show compliance with the design objectives of a 'Principal Drive' and 'Plaza', actual site and building configuration may vary.



Figure 1.5- 'Principal Drive' Conceptual Section



Trellis structures and integrated planting



Clerestory windows and natural lighting



Outdoor Seating Areas



Example of typical row of retail facades



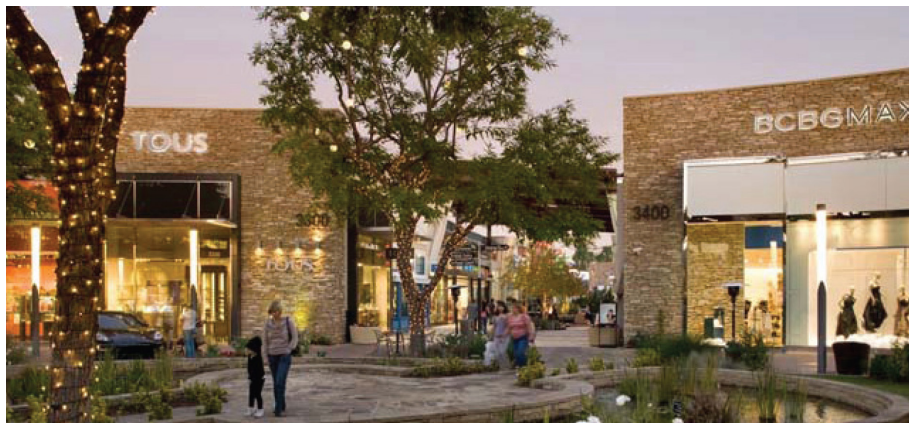
Awnings and Shading Devices



Simple facades



Lighting and Signage



Trees and plantings informally integrated into public areas



Arcades

## 2.4 TOWNHOMES

Townhome development at Oak Knoll will be designed to create functional and pedestrian friendly streetscapes. The orientation and layout of buildings should create 'addresses' and a sense of place for individual homes. Townhomes will feature required open space as defined in the City of Oakland's Zoning Ordinance. Final design of towhhome parcels will be submitted to the City of Oakland in a form of a Final Development Plan, and designs will be evaluated using these guidelines.

### Design Objectives:

- Create a 'sense of address' and a front door for each unit by providing 'door yards', gates, and access to public streets and paseos;
- All units should feature covered entry areas either in the form of a stoop or entry porch;
- Variation of design is encouraged, and corner units should be treated differently than middle units;
- End facades should be treated as high visibility and should feature windows, entries where appropriate, and other design features normally on the front facade.
- Odd numbers of units in a row are encouraged;
- Stepping between units is encouraged to provide private balconies and a varied building frontage as viewed from the street.
- Landscape planting should be integrated in with streetscapes and provide screening for parking & alleys. Please refer to the Preliminary Development Plan for example designs for Paseos and Pocket Parks.



'Door yards' and orientation of entry onto a street or pedestrian path



Typical Elevation example



Corner 'end facades'



Stepped Massing



Balconies and individualized unit designs



Typical Elevation Example



Typical Elevation Example

## 2.5 BUILDING MASSING AND PLACEMENT

Building setback and height requirements are contained in Zoning Ordinance and vary according to lot size and building type. In addition to those standards, the intent of these guidelines is to address additional massing considerations such as 'under the roof' or 'attic' 1/2 stories, and setback garages. These considerations are described further in the Architectural chapter.

Within the small lot area (lots of less than 4000 sf), a one story covered porch is allowed to encroach into the front yard setback as defined in the Zoning Ordinance..

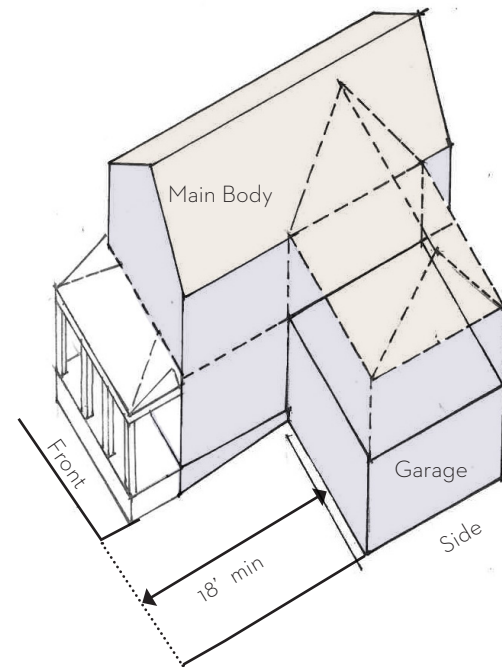


Figure 1.7, Porch and Garage Placement

## 2.5 DRIVEWAYS AND GARAGE PLACEMENT

Driveways and garages within Oak Knoll should be designed to reinforce the dominance of a tree-lined streetscape.

Limiting curb cuts to 16' in width is strongly encouraged, where feasible, for front loaded lots.

Driveway width in front of 2 car garages should be 18' wide at garage entry allowing for two off-street parking spaces in front of garage. Refer to adjacent Figure 1.8.

Refer to Chapter 4.0, Landscape Guidelines, for allowable paving materials for driveways

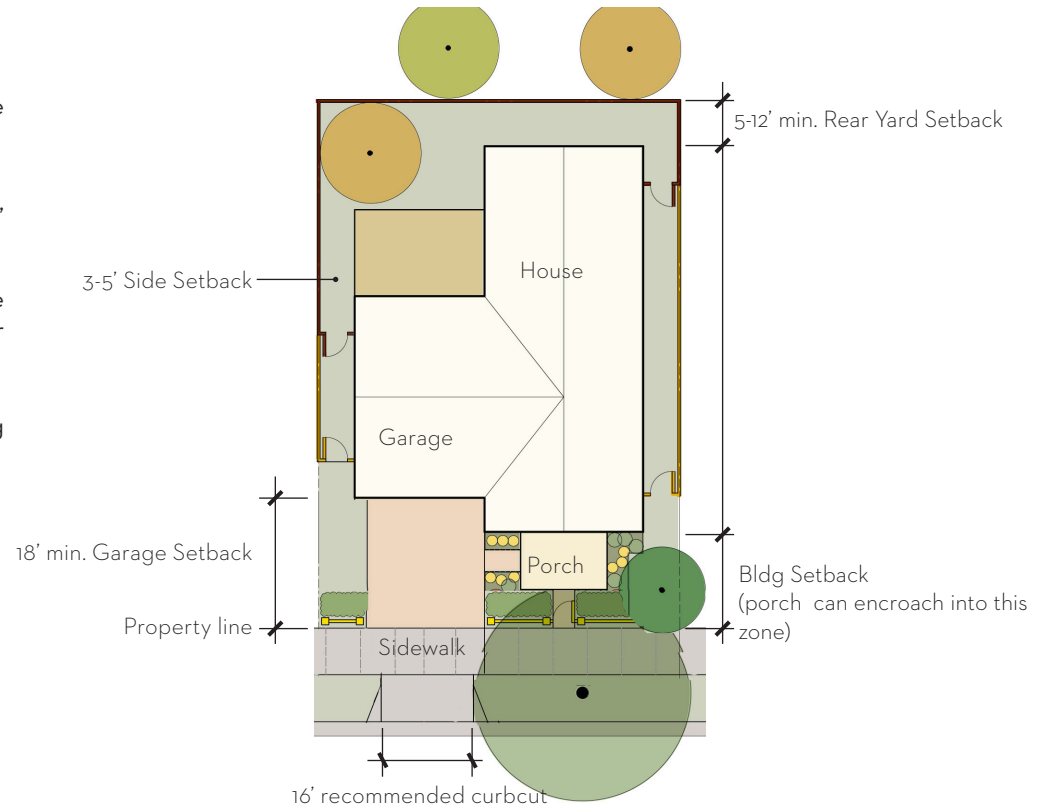


Figure 1.8, Small lot typical siteplan



An architectural sketch of a building facade, rendered in a light brown or sepia tone. The drawing shows a multi-story structure with a prominent gable roof on the left side. The gable contains a window. Below the gable, there is a large window with a decorative frame. To the right of this, there are several more windows of varying sizes and styles, some with decorative elements. The sketch includes lines for structural elements like roof trusses and window frames. There are some loose, sketchy lines on the left side, possibly representing trees or landscaping. The overall style is that of a preliminary architectural drawing or a conceptual sketch.

# 3.0 ARCHITECTURAL GUIDELINES

## 3.1 THE 'BAY AREA' REGIONAL STYLE

The Bay Area has a unique and home-grown residential character which has evolved in response to the local climate, cultural history, and lifestyle of its inhabitants. Many respected names in the field of architecture, landscape design and development have contributed to this character throughout history. The East Bay's early development phase included names like Bernard Maybeck, Julia Morgan, Walter Ratcliff, Henry Gutterson, Mason/McDuffie, and Frederick Law Olmsted; the mid-century included names like Joseph Eichler, William Wurster, Joe Esherick, Charles Moore, and many others. While the styles that make up this character are diverse, they are bound by common themes that form a sense of place and will inform the identity of Oak Knoll. Among these themes are:

- Buildings which connect to and are inspired by the natural setting
- Simple building mass with additive elements
- Natural Materials (wood, stone, terra cotta, stucco)
- Subdued earth-tone paint colors and light colored stuccos



Bay Area Regional Style - Shingle



Bay Area Regional Style - Contemporary



Bay Area Regional Style - Mid Century Modern

For the purposes of style classification, the following styles are identified as typical to the area and considered appropriate to Oak Knoll:

### ARTS & CRAFTS

- Craftsman Bungalow
- Shingle
- Tudor
- Arts and Crafts

### MEDITERRANEAN

- Spanish Colonial
- Mission
- Tuscan

### CALIFORNIAN

- Farmhouse
- California Modern (mid-century modern)
- California Contemporary



Bay Area Regional Style - Arts and Crafts



Bay Area Regional Style - Spanish Colonial

## THE HISTORIC PRECEDENTS

The style of the architecture at Oak Knoll draws from examples of the historic styles typical in the area. These images show inspirational historic 'ancestors'; new homes will not be replications of these but rather derived from similar design principles. These principles will then be applied to current designs taking into consideration today's materials, construction practices, and modern lifestyles.



Bay Area Regional Style - Craftsman Bungalow



Bay Area Regional Style - Tuscan



Bay Area Regional Style - Arts and Crafts



Bay Area Regional Style - Contemporary

## 3.2 ARCHITECTURAL STYLE MATRIX - BY FAMILY

	Massing / Roof Form	Windows and Doors	Porches / Balconies and Details	Materials and Color*
<b>ARTS AND CRAFTS</b>				
Craftsman Bungalow	<ul style="list-style-type: none"> <li>Lower pitch gable roofs (4/12 - 8/12)</li> <li>Broad eaves with exposed rafters</li> <li>Wide shed dormers</li> <li>1/2 story upper floors</li> </ul>	<ul style="list-style-type: none"> <li>Double hungs, single or grouped</li> <li>Casements, single or grouped</li> <li>Bay windows</li> <li>Wide panelled entry doors</li> </ul>	<ul style="list-style-type: none"> <li>Wide porches, often covered by primary roof form, integrated into primary mass</li> <li>Thick porch columns</li> </ul>	<ul style="list-style-type: none"> <li>Wood or composite siding and trim</li> <li>Cast stone brick used as accent materials</li> <li>Subdued earth tone colors with warm accent colors</li> </ul>
Shingle	<ul style="list-style-type: none"> <li>Medium pitch gable and hip roofs (6/12 - 12/12)</li> <li>Gable and shed dormers</li> <li>1/2 story upper floors</li> </ul>	<ul style="list-style-type: none"> <li>Cottage style double hungs</li> <li>Casements, single or grouped</li> <li>Bay windows</li> <li>Panelled entry doors</li> </ul>	<ul style="list-style-type: none"> <li>"innie" porches, often covered by primary roof form, integrated into primary mass</li> </ul>	<ul style="list-style-type: none"> <li>Wood shingle with wood or composite trim</li> <li>Natural stained base color with darker accent color on trim</li> </ul>
Tudor Arts and Crafts	<ul style="list-style-type: none"> <li>Steeper pitch gable roofs (8/12 - 18/12)</li> <li>Cross-gables and dormers</li> <li>1/2 story upper floors</li> <li>Assymetric massing</li> </ul>	<ul style="list-style-type: none"> <li>Casements, single or grouped</li> <li>Bay windows</li> <li>Arched entry doors, pointed or round</li> </ul>	<ul style="list-style-type: none"> <li>Assymetric entry features (stoops or porches) integrated into primary bldg mass</li> </ul>	<ul style="list-style-type: none"> <li>Wood and stucco walls</li> <li>Brick used as accent material</li> <li>White or rich earth tone base color with darker accent color on trim</li> </ul>
<b>MEDITERRANEAN</b>				
Spanish Colonial Mission revival	<ul style="list-style-type: none"> <li>Lower pitch hip roofs (4/12-8/12)</li> <li>Secondary shed roofs</li> <li>Secondary flat roofs areas with shaped parapets</li> </ul>	<ul style="list-style-type: none"> <li>Casements, single or grouped</li> <li>Tall double hungs</li> <li>Arched entry doors</li> </ul>	<ul style="list-style-type: none"> <li>Covered entry arcades</li> <li>Juliet balconies</li> <li>Painted metal railings and window grilles</li> </ul>	<ul style="list-style-type: none"> <li>Stucco walls</li> <li>Terra cotta roof tiles</li> <li>Colored glazed tile and cast ornamental details as accents</li> <li>Light colored walls</li> </ul>
Tuscan	<ul style="list-style-type: none"> <li>Lower pitch hip roofs (4/12-8/12)</li> <li>Projected eaves with flat soffit and corbels</li> </ul>	<ul style="list-style-type: none"> <li>Tall casement style windows</li> <li>Pedimented front entry</li> </ul>	<ul style="list-style-type: none"> <li>Loggias at entry or upper level</li> <li>Balconies with balustrades or painted metal railings</li> </ul>	<ul style="list-style-type: none"> <li>Stucco walls</li> <li>Cast stone as accents</li> <li>Earth colored walls (sienna and umber)</li> </ul>
<b>CALIFORNIAN</b>				
Farmhouse Traditional	<ul style="list-style-type: none"> <li>Medium pitch gable roofs (6/12 - 12/12) and simple primary mass</li> <li>Gable and shed dormers</li> <li>1/2 story upper floors</li> </ul>	<ul style="list-style-type: none"> <li>Double hungs, single or grouped</li> <li>Casements, single or grouped</li> <li>Panelled entry doors</li> </ul>	<ul style="list-style-type: none"> <li>Front or side porches - shed roof, additive to primary mass</li> <li>Shed awnings</li> </ul>	<ul style="list-style-type: none"> <li>Vertical wood or composite siding, board and batten</li> <li>White and light colors</li> </ul>
Mid Century Modern	<ul style="list-style-type: none"> <li>Lower pitch gable and hip roofs (3/12 - 6/12)</li> <li>Broad horizontal eavelines, with exposed rafters or flat soffits</li> <li>Secondary shed roofs</li> <li>Secondary low-pitch shed roofs</li> </ul>	<ul style="list-style-type: none"> <li>Wide horizontal window rows</li> <li>Sliding, double hung, or casement</li> <li>Corner windows</li> </ul>	<ul style="list-style-type: none"> <li>Wide extended eaves over entry areas</li> </ul>	<ul style="list-style-type: none"> <li>Vertical or horizontal wood or composite siding</li> <li>Subdued natural colors</li> </ul>
Contemporary	<ul style="list-style-type: none"> <li>Stepped building massing</li> <li>Flat roofs</li> <li>Monopitch roof, split gable monopitch</li> </ul>	<ul style="list-style-type: none"> <li>Large expanses of glass, gridded or single frame</li> <li>Sliding or casement</li> <li>Corner windows</li> </ul>	<ul style="list-style-type: none"> <li>Flat roof or shed awning over entry</li> </ul>	<ul style="list-style-type: none"> <li>Vertical or horizontal wood or composite siding</li> <li>Smooth-textured stucco walls</li> <li>Whites and subdued natural colors</li> </ul>

\*See Appendix A for detailed spreads of Materials and Colors



Craftsman Bungalow



Shingle



Tudor



Arts and Crafts



Spanish Colonial



Spanish Colonial



Mission



Tuscan



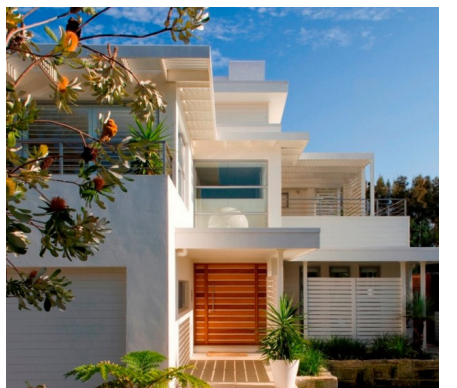
Farmhouse



Mid Century Modern



Contemporary



Contemporary

## 3.3 MASSING – PRIMARY VOLUMES

### BUILDING ORIENTATION

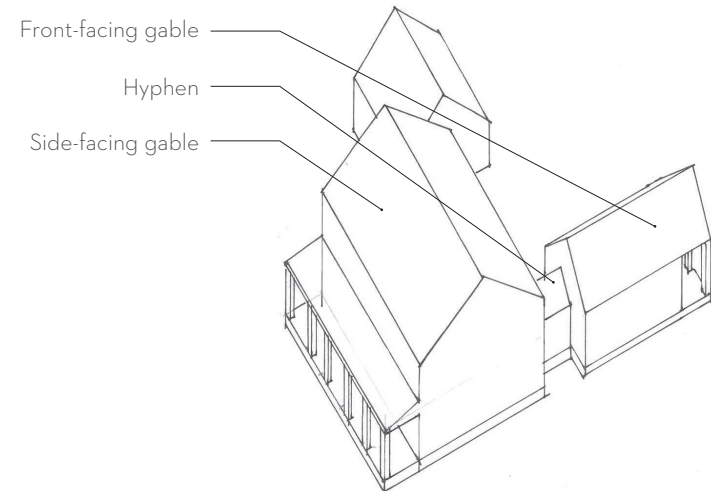
A variety of symmetrical and asymmetrical massings can be used when laying out an Oak Knoll home. First, it is important to determine the building orientation based on lot conditions. Typically, this will be perpendicular to the street.

### SECONDARY VOLUMES

Next, an assessment of secondary volumes -- garages and additional building wings -- will help determine the appropriate roof profile. This may be gable, gambrel, hip, shed, or a combination thereof. For further information on roof profiles, see Section 3.3: Roofs.

### ADDITIVE BUILDING ELEMENTS

Ultimately, the massing should be simple and understated, and should provide a backdrop to unique building elements like porches, dormers, and other details while logically shaping the interior spaces.



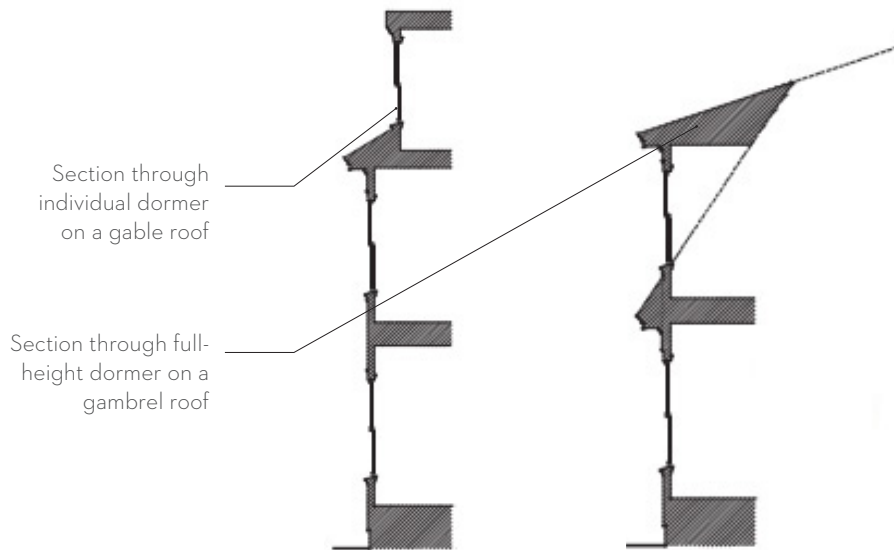
Primary and Secondary Volumes

# 3.4 ROOFS

## ROOF TYPES AND SLOPES

Acceptable roof types include front-facing and side-facing gable, gambrel, hip, and shed roofs, or some combination thereof. Flat roofs are permissible but will be reviewed during the Final Development Plan (FDP) process for their visual impact on adjacent properties. Please refer to the Architectural Style Matrix on pg 30 for roof design recommendations by style.

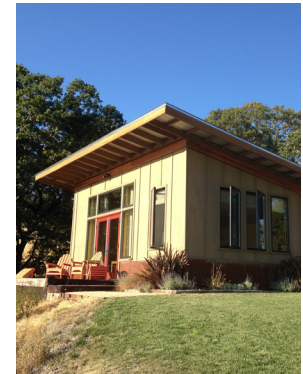
As appropriate to the chosen style, 'under the roof' style upper levels are encouraged to diminish the bulk of 2 and 3 story homes.



Flat roofs



12/12 steeper pitch roof with dormers



3/12 shed roof



12/12 steeper pitch roof with dormers



4/12 tile roof

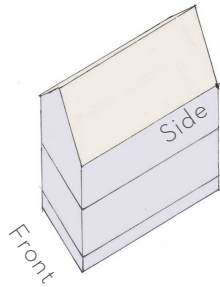


1. PRIMARY VOLUME

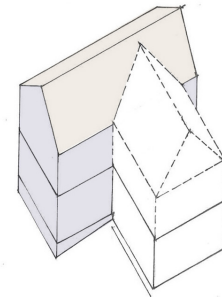
2. SECONDARY VOLUME

DETACHED LOTS

- Most small lots will have Primary Volumes that are oriented perpendicular to the street.
- May be one to two-and-a-half stories.

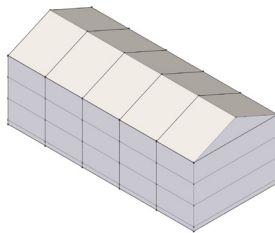


- Most Secondary Volumes on small lots will be oriented perpendicular to Primary Volumes
- Shall be setback from the Primary Volume a minimum of two (2) feet
- May be one to 2.5 stories.
- May be detached from the Primary Volume.

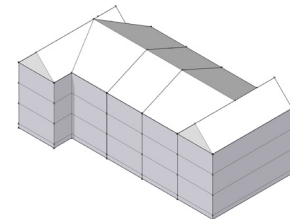


ATTACHED UNITS - TOWNHOMES

- Primary Volumes oriented parallel to the street or entry walk
- May be three stories



- Create secondary volumes to differentiate roofscape where appropriate
- Corner Units should be differentiated

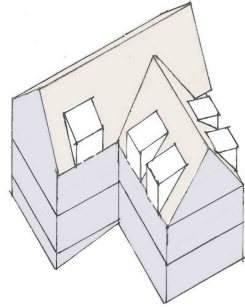


### 3. COMPONENTS/FEATURES

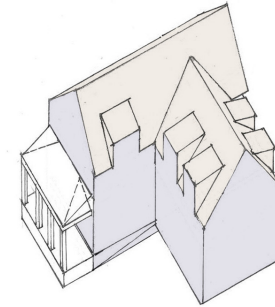
### 4. PORCHES

#### DETACHED LOTS

- Dormers, chimneys, bay windows, and other facade components shall be added to provide facade interest.

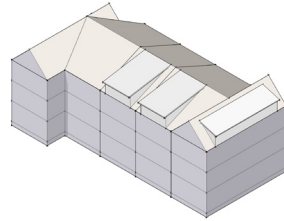


- Porches may be single-bay, full-width, wraparound or stacked.
- Refer to pages 46 & 47 for examples of porch types.

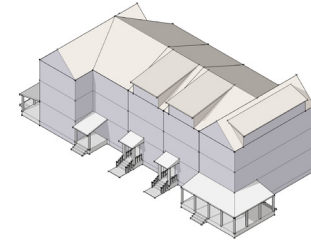


#### ATTACHED LOTS - TOWNHOMES

- Dormers, chimneys, bay windows, and other facade components shall be added to provide facade interest.

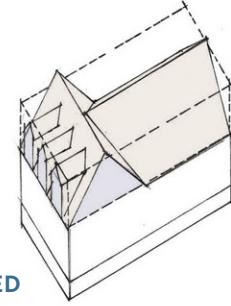
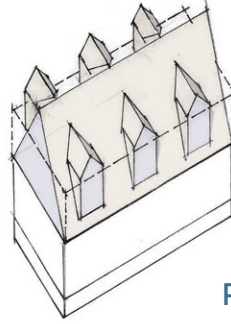
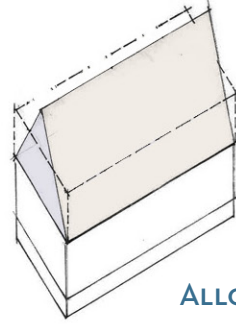
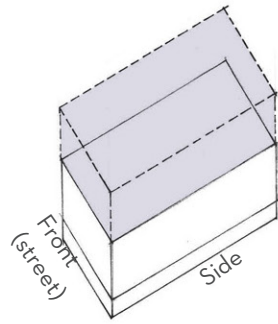
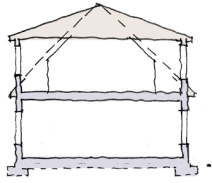


- Porches may be single-bay, full-width, wraparound or stacked.
- Refer to pages 46 & 47 for examples of porch types.

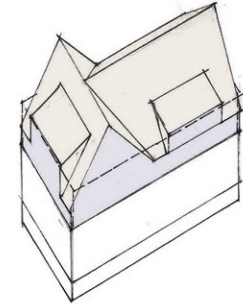
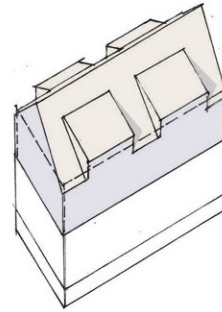
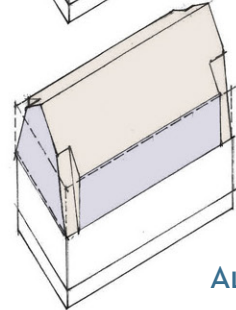
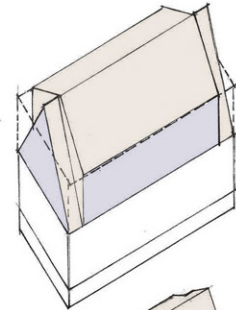
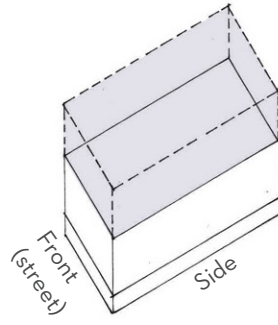
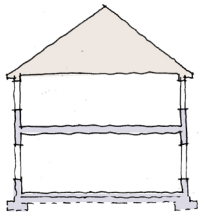
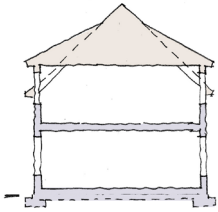


ROOF & DORMER OPTIONS- PERPENDICULAR TO THE STREET

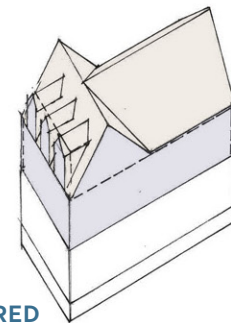
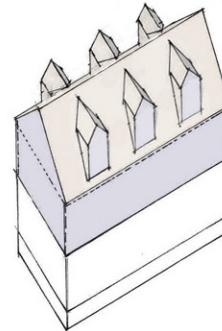
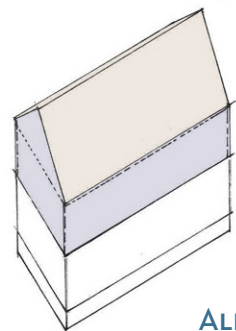
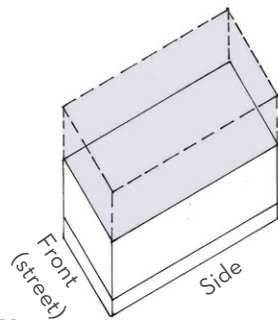
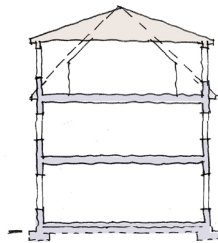
1.5 STORIES



2 STORIES

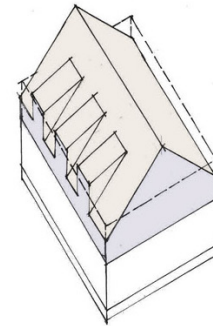
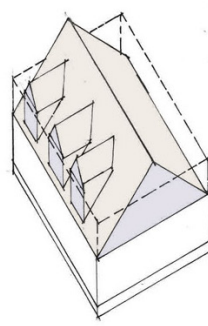
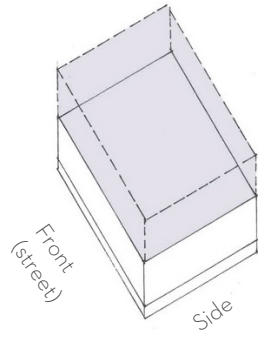
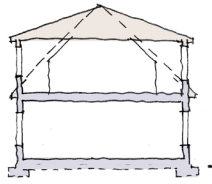


2.5 STORIES



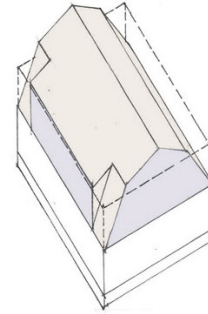
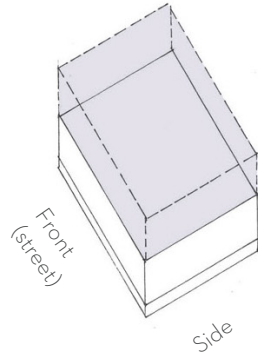
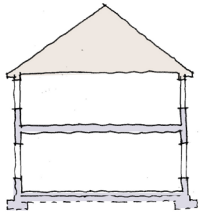
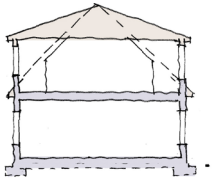
# ROOF & DORMER OPTIONS- PARALLEL TO THE STREET

1.5 STORIES



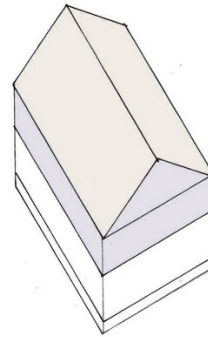
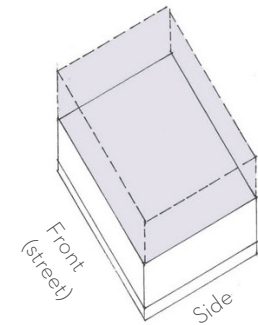
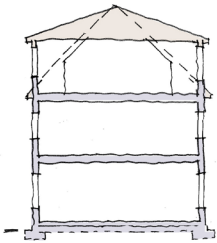
PREFERRED

2 STORIES



ALLOWED

2.5 STORIES



ALLOWED

## ROOF MATERIALS

Please refer to the Appendix A for acceptable roof materials.

## SUCCESSFUL ROOF DESIGNS

While a variety of roof types suit the Oak Knoll home, successful designs will support the simple massing of primary and secondary volumes and interior spaces, visually reduce the scale of the home, and provide adequate shading.

## DORMER SIZING

Dormers are an important element that allow upper stories of a home to be usable as well as visually diminishing the scale of the upper level. Dormers may contain one window, or a string of windows, depending on the functional needs of the spaces within.

Dormer eaves and overhang details should be scaled accordingly, and should be consistent with the overall roof details.

All dormers shall be functional and bring light into occupiable interior spaces.

## DORMER SIDING

Siding may be applied on the side or front walls of dormers either horizontally or sloped to match the adjacent roof.



1/2 Story 2nd floor with dormers

## 3.5 HIGH VISIBILITY FACADES

High Visibility Facades are visible from the street and from open space. High Visibility Facades are entry facades; hillside rear facades (facing the view); and corner lot facades. The High Visibility Facade of all homes should welcome residents, be inviting to neighbors and guests, and must follow guidelines defined in this section.

### HIGH VISIBILITY FACADES - OPEN SPACE

While the entry facades of all homes in Oak Knoll shall be considered High Visibility Facades, select facades that face the Open Space shall also be considered High Visibility Facades. Use of porches and balconies are encouraged on these facades, and they should be designed with their visibility in mind, as well as the privacy of the homeowner.

### CORNER LOT FACADES

Corner lot facades should carry distinct compositional and material elements from the entry facade to the side facade, to create a dynamic perspective of the home from the street. Corner lot facades shall have consistent details and elements on elevations facing both streets. The rhythm of openings established on the entry facade shall continue on the side facade that faces the street, and divided window patterns shall be consistent on both elevations. If shutters are incorporated on the entry facade they shall likewise be incorporated on the side facade that faces the street.

### ADDITIVE FACADE ELEMENTS

Once the design of the High Visibility Facade openings has been determined, additive building elements like porches and dormers should follow the rhythm of the facade composition. Wraparound porches are encouraged on corner lots, as well as projected window bays. Porch columns should be spaced equally to either side of facade openings. Satellite dishes and external antennas are not permitted on High Visibility Facades.

### SUCCESSFUL EXECUTION OF SECONDARY FACADES

Secondary Facades that successfully follow the above guidelines will support a composition of the Bay Area home that is balanced and continuous rather than one-sided and fragmented.



Secondary Facades

## 3.6 OPENINGS - WINDOWS

### WINDOW TYPES

Homes may have single-hung, double-hung, triple-hung, awning, and casement windows. Slider style windows are also permissible where appropriate to the chosen style (see style matrix on pg 30). Square transom windows are allowed on Secondary Facades, and may be used in bedrooms, bathrooms, stairwells, etc. Arch windows shall be permitted where appropriate to the style. Please refer to the Architectural Style Matrix on pg 30 for window recommendations by style. Bay windows may encroach into front and rear yard as permitted by zoning and building codes. All windows shall be fully trimmed on the exterior with appropriate head, side, and sill details. Mitered joints are not permitted.

### WINDOW PROPORTIONS AND TRIM

Windows may be mulled together to achieve wider expanses of glass, but shall not exceed 12' in total width. Windows may have no muntins, a 2 over 2, 4 over 1, 4 over 4, 6 over 1, or 6 over 6 muntin pattern. True divided lites are preferred, simulated divided lites are acceptable, and removable muntins are prohibited. Wood and composite trim materials are permitted and foam trim is not allowed.

### SHUTTERS

If shutters are incorporated in Primary Facades they should likewise be incorporated in High Visibility Facades. Each shutter shall be a minimum of half of the window dimension. Louvered or panelized shutters are acceptable.



Casement Style windows



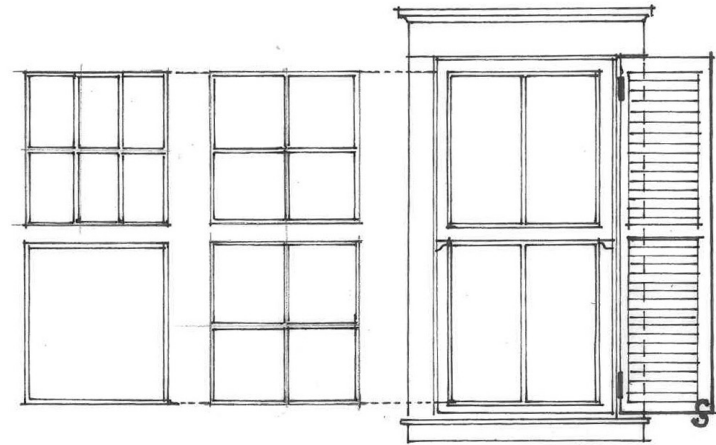
Double-hung windows



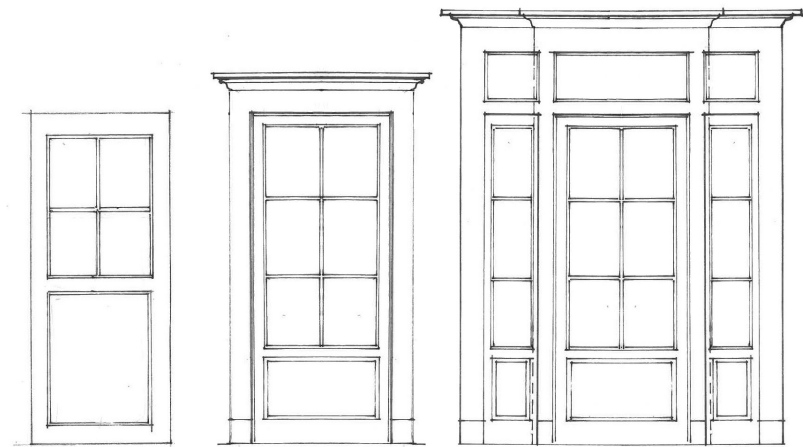
Casement Style windows



Casement Style Windows



6 over 1; 4 over 4; and 2 over 2 muntin patterns





## 3.7 EXTERIOR DOORS

Exterior Main Entry doors can be flat or traditionally paneled doors. Please refer to the Architectural Style Matrix on pg 30 for design recommendations by style.

## 3.8 PORCHES & STOOPS

### TYPES

The porch or stoop is the signature element of an Oak Knoll home. As such, all homes must have either a porch or stoop. Multiple types are acceptable and encouraged, from single-bay to full-width, wraparound, and stacked. Pages 41 and 42 illustrate examples of porch and stoop types. Entry Courts are also an entry feature of certain styles of homes and are addressed in the landscape section.

### PORCH DIMENSIONS

All porches or stoops on detached homes shall have a minimum covered area as defined in the Zoning Ordinance, and designed in a manner appropriate to the style of architecture.

Single story covered porches are allowed encroachments into front yard setbacks as defined in the Zoning Ordinance.



Entry Porches

## PORCH DETAILS

Porch columns should be with round or square profiles, and shall have a minimum dimension of six (6) inches. Columns shall have defined capitals and bases. Porch design should be consistent with the chosen style of the house. Please refer to the Architectural Style Matrix on pg 30 for design recommendations by style.

Porch beams shall align over supporting columns. Porch eaves and rakes should extend beyond porch beams. Porch ceilings must be fully trimmed.

Porch railings and balusters where required by code should be designed in a manner appropriate to the chosen style.

## STOOPS

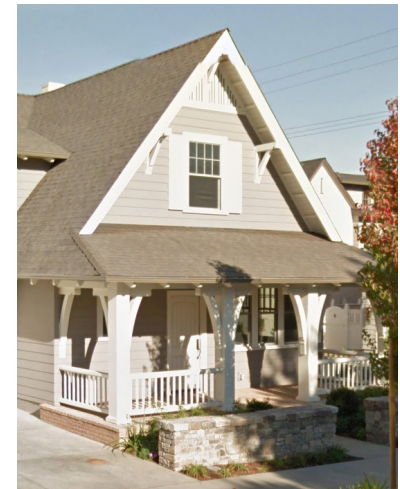
Stoops should be detailed in a similar way to porches, but are smaller in size and may be in the form of a recessed entry that indents into the building wall. The landings and covered areas of stoops shall have minimum dimensions as defined in the Zoning Ordinance.



Entry Porch



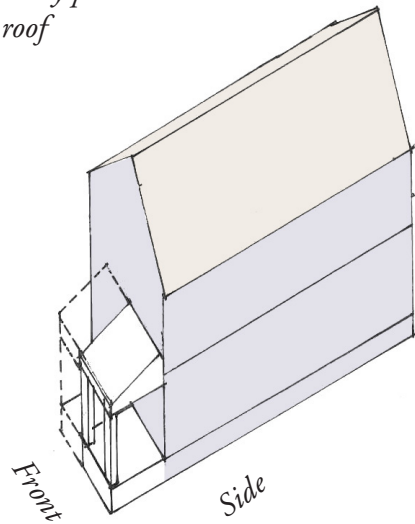
Recessed Entry



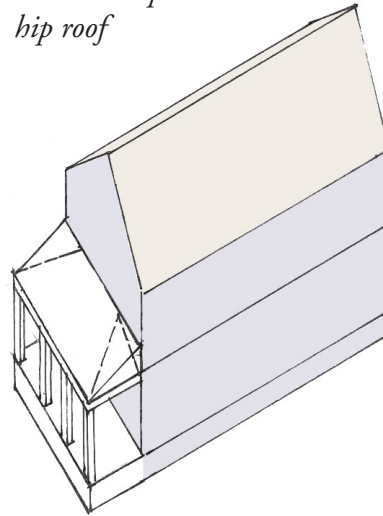
Entry Porch

3.6 PORCHES- *Porch and Stoop Types*

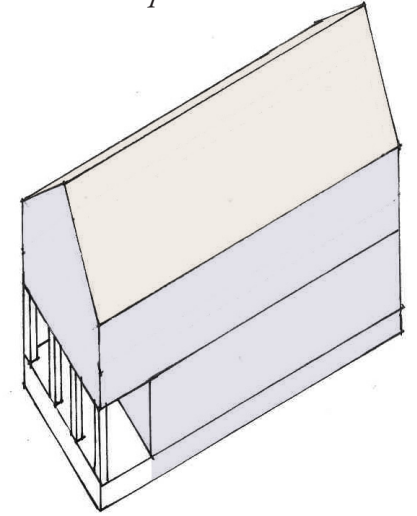
*Single-bay porch with shed roof*



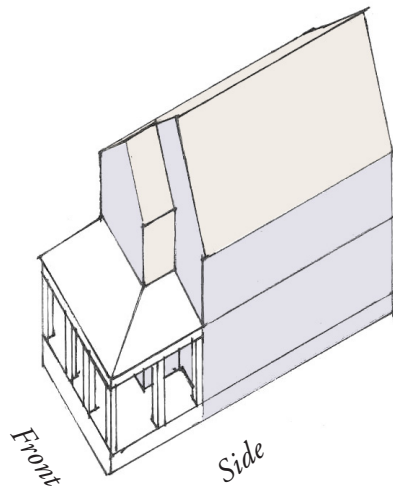
*Full-width porch with hip roof*



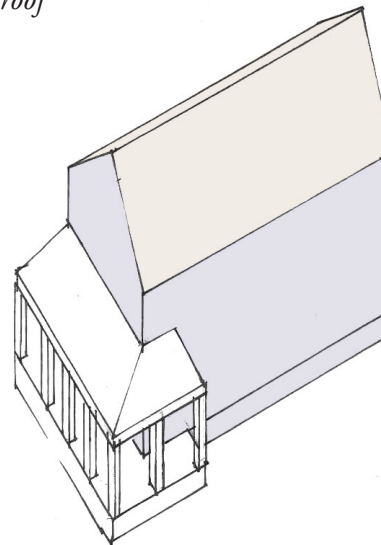
*Full-width porch*



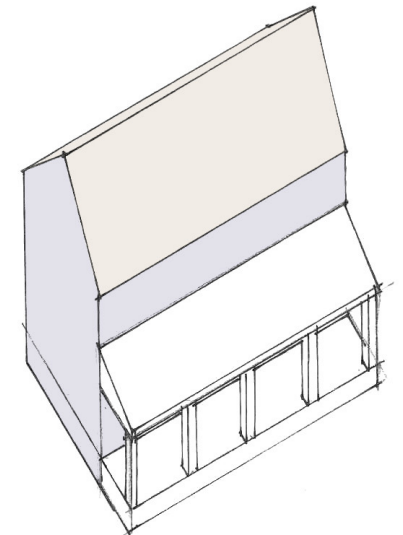
*Wraparound porch with hip roof*



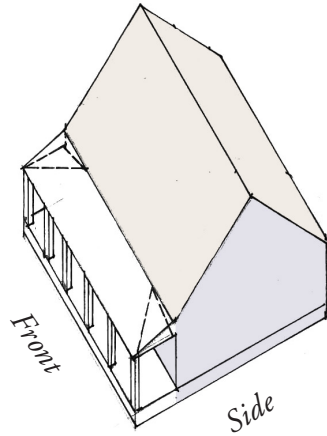
*Wraparound porch with hip roof*



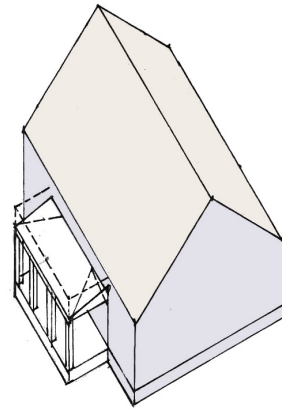
*Side porch with shed roof*



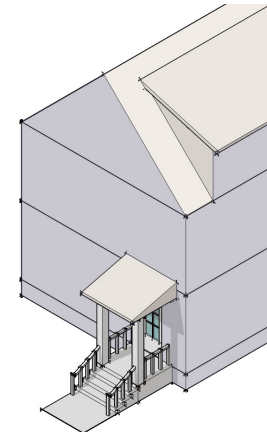
*Full-width porch*



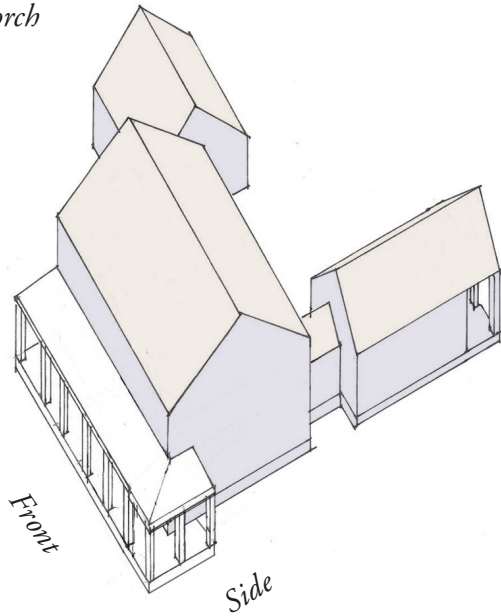
*Single-bay porch*



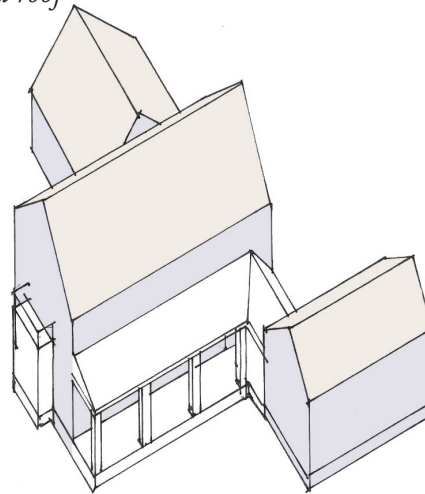
*Standard Stoop*



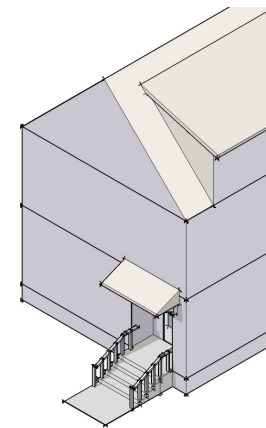
*Full-width porch*



*Single-bay porch with flat roof; side porch with shed roof*



*Inset Stoop*



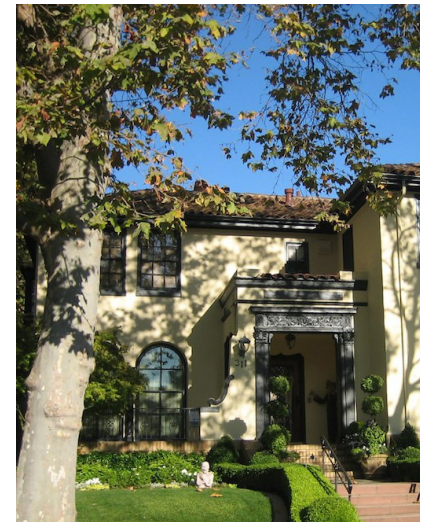
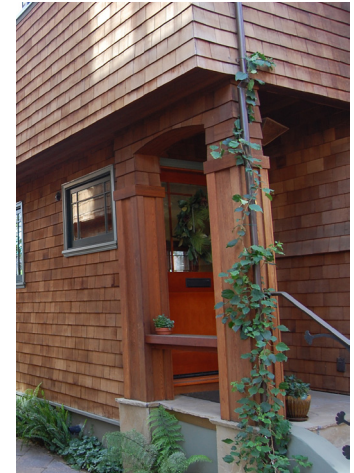
## PORCH MATERIALS

Porches may be constructed from wood, wood-like composites, stucco, or concrete faced with brick or stone veneer. Entry stoops, porches, and stairs that are constructed with wood shall be screened with wood or manufactured wood trim or lattice.

Entry stoops or porches constructed of masonry may have stair risers and treads constructed of masonry and may be finished with brick pavers. When finished walking surfaces, including stair treads, are brick pavers, all vertical surfaces from the top of the porch deck to grade shall be of brick. Bare or painted concrete is also a permitted finish material.

The porch ceiling may be composite bead-board planks or wood with appropriate molding.

Composites, and fiberglass trim moldings are allowed on a case-by-case basis as reviewed in Design Review. Vinyl or foam trim is prohibited. Refer to Chapter 4.0: Landscape for planting requirements at base of porch.



## 3.9 GARAGES

### GARAGE DIMENSIONS

The design and placement of garages is important to the creation of a pleasing streetscape and a domestic 'neighborhood' feel. A minimum setback is required to allow a parked car in front of garage within the lot and not overlapping with adjacent sidewalks or common drive aisles. Exceptions may be granted through the Design Review process to allow the garage face closer to the front lot line.

Garages preferably will have individual carriage doors, but double garage doors are permissible as well. Garage doors must abide by the minimum and maximum dimensions defined in the Zoning Ordinance. Garage doors should be traditionally panelled, and windows courses at the upper panel are desirable features. Single car garages and tandem garages are also encouraged where circumstances favor this layout on the lot.

### GARAGE DETAILS

Where the garage is not integrated into the primary mass of the home, they shall be considered a Secondary Volume, and shall have the same or shallower roof pitch than that of the Primary Volume of the home, and set back from the Primary Volume. Garage doors should incorporate details that complement the design of Entry and Secondary Facades, such as windows, patterned paneling, trellis and roof details.



## 3.10 LIGHTING

### ARCHITECTURAL LIGHTING

A well-lighted porch or stoop is a critical element to the Oak Knoll streetscape. As such, all homes must have porch lighting appropriate to the style of the house.

Garages should also have exterior lighting integrated over or adjacent to the door bays, and should be shielded.

No uplighting of buildings is permitted.



## 4.0 LANDSCAPE GUIDELINES





## 4.1 LANDSCAPE VISION

The landscape design for Oak Knoll is intended to integrate the new community into an existing context of hillsides, creeks and drainages, and oak woodland. Proposed landscape elements will reinforce the new patterns of buildings, roads, public spaces, and recreational and open space amenities, creating a framework for the new community while also providing for habitat restoration and sustainability.

The proposed landscape elements are also intended to celebrate the rich heritage and historic context of the North Oakland communities, celebrating historic community values of respect for land, nature, and a tradition of craftsmanship that was expressed by neighborhood community designs at the turn-of-the century in the East Bay neighborhoods of Berkeley, Claremont, Piedmont, and Rockridge.

The community landscape is shaped to provide accessible open space and access to nature, and to encourage active and healthy outdoor living. Neighborhoods are woven together with natural open space settings and carefully designed streets with generous sidewalks, punctuated by neighborhood and pocket parks. Landscape materials emphasize the use of native materials and plant communities within natural settings, intended to restore the site's ecology and benefit wildlife, while presenting a unique, nature-rich environment for the residents of the community.

In order to promote the conservation and efficient use of water, landscaping shall comply with the provisions established in the California Code of Regulations Title 23, Division 2, Chapter 2.7 Model Water Efficient Landscape Ordinance (MWEL0).

## 4.2 STREETScape DESIGN

Street trees are important thematic elements of the neighborhoods, where strong patterns reinforce the neighborhood identity, define road edges and provide a shaded overstory. A strong overhead tree canopy will modify the climate and bring streets into a more balanced scale with the overall landscape.

The community streetscape features a natural setting of Coastal Oak woodland, comprised of native London Plane and Coast Live Oak along street edges. Plantings are low groundcovers in composed drifts, using selections from the Approved Plant List. (Refer to the Preliminary Development Plan (PDP)) for public street sections.)

The Creekside Village, Retail Village, Creekside Townhomes and Garden Court neighborhoods utilize native Oak woodland as the predominant framework plantings, with London Plane, Trident Maple, Red Maple and Brisbane Box as canopy street or parking lot trees.

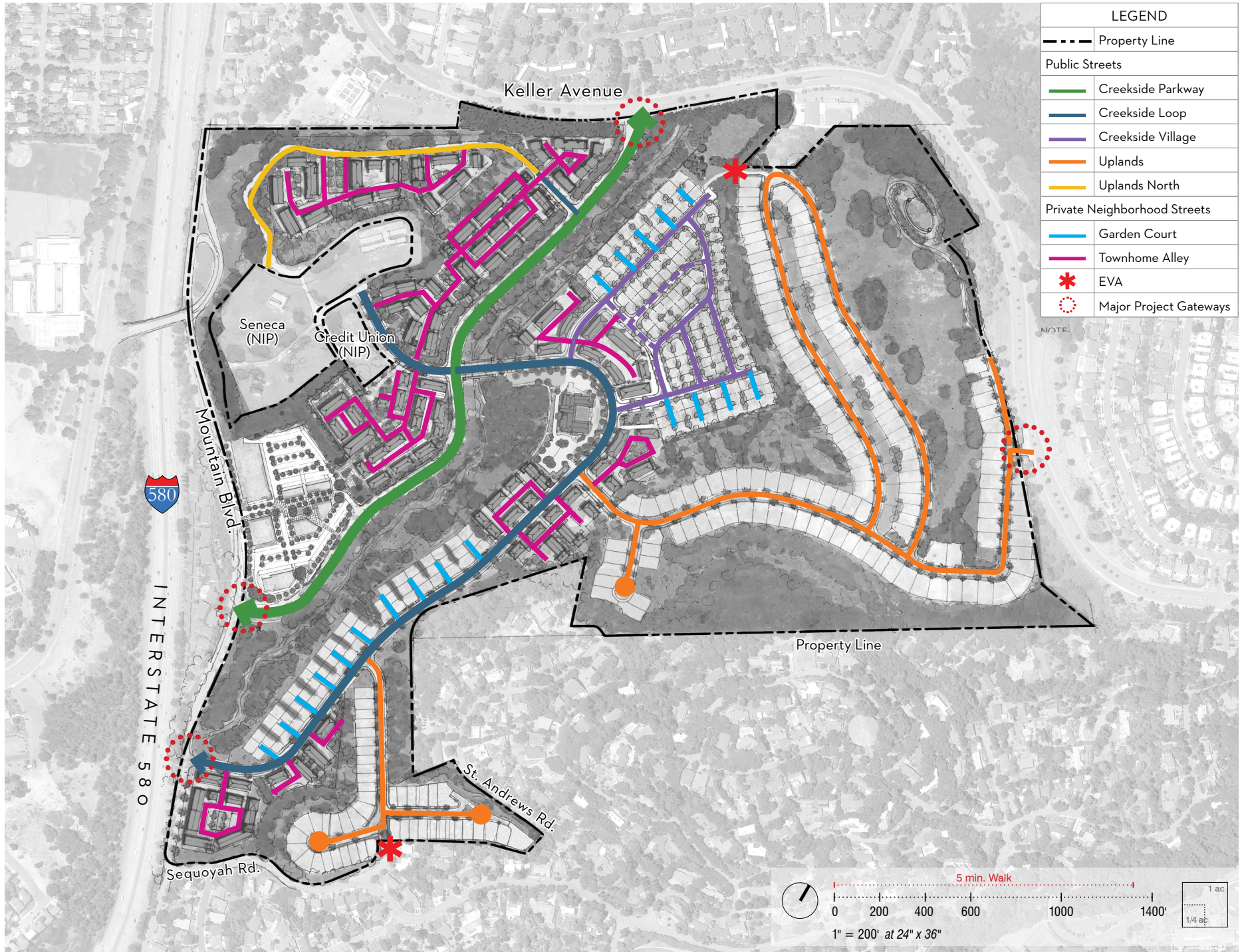


Figure 4.1- Circulation Network

	CREEKSIDE PARKWAY	CREEKSIDE LOOP	CREEKSIDE VILLAGE	UPLANDS	TOWNHOME ALLEY	GARDEN COURT
On-street Parking	Parallel on 2 Sides	Parallel on 1 Side	Primary: Parallel on 1 side Secondary: None	Primary: Parallel on 2 sides Secondary: Parallel on 1 side	Primary: Parallel on 2 sides Secondary: Parallel on 1 side	None
Bike Lane	Class I multi-use path	Class III	None	None	None	None
Landscape Character	- Large deciduous street tree	- Large deciduous street trees	- Large deciduous street trees with medium evergreen and deciduous alley trees  - Fall color	- Large evergreen street tree	- Medium deciduous trees  - Fall color	- Medium deciduous trees  - Fall color
Drainage	Bulb-out Infiltration Basins in ROW	Bulb-out Infiltration Basins in ROW	Bulb-out Infiltration Basins in ROW/Parks	Bulb-out Infiltration Basins in ROW/ In Board Bioswales	In-tract detention and infiltration basins	In-tract infiltration basins
Drainage in R.O.W.	Yes	Yes	Yes	Yes	No	No
Representative Landscape Species	STREET TREE: - London Plane or - Accolade Elm	STREET TREE: - London Plane 'Columbia'	STREET TREE: - London Plane  ALLEY TREE: - Trident Maple - 'Elegant' Brisbane Box	STREET TREE: - Coast Live Oak	STREET TREES (North Creekside): - 'Redpointe' Red Maple  (South Creekside): - Trident Maple	COURT TREE: - 'Redpointe' Red Maple



London Plane



Coast Live Oak



'Redpointe' Red Maple

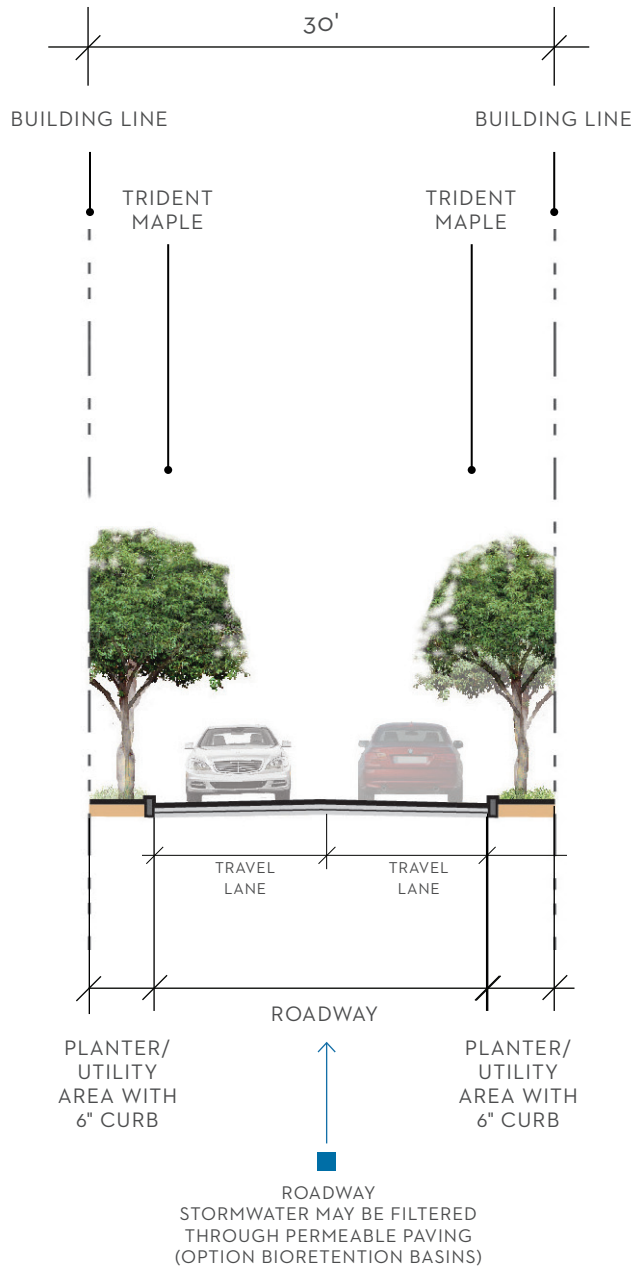


Trident Maple

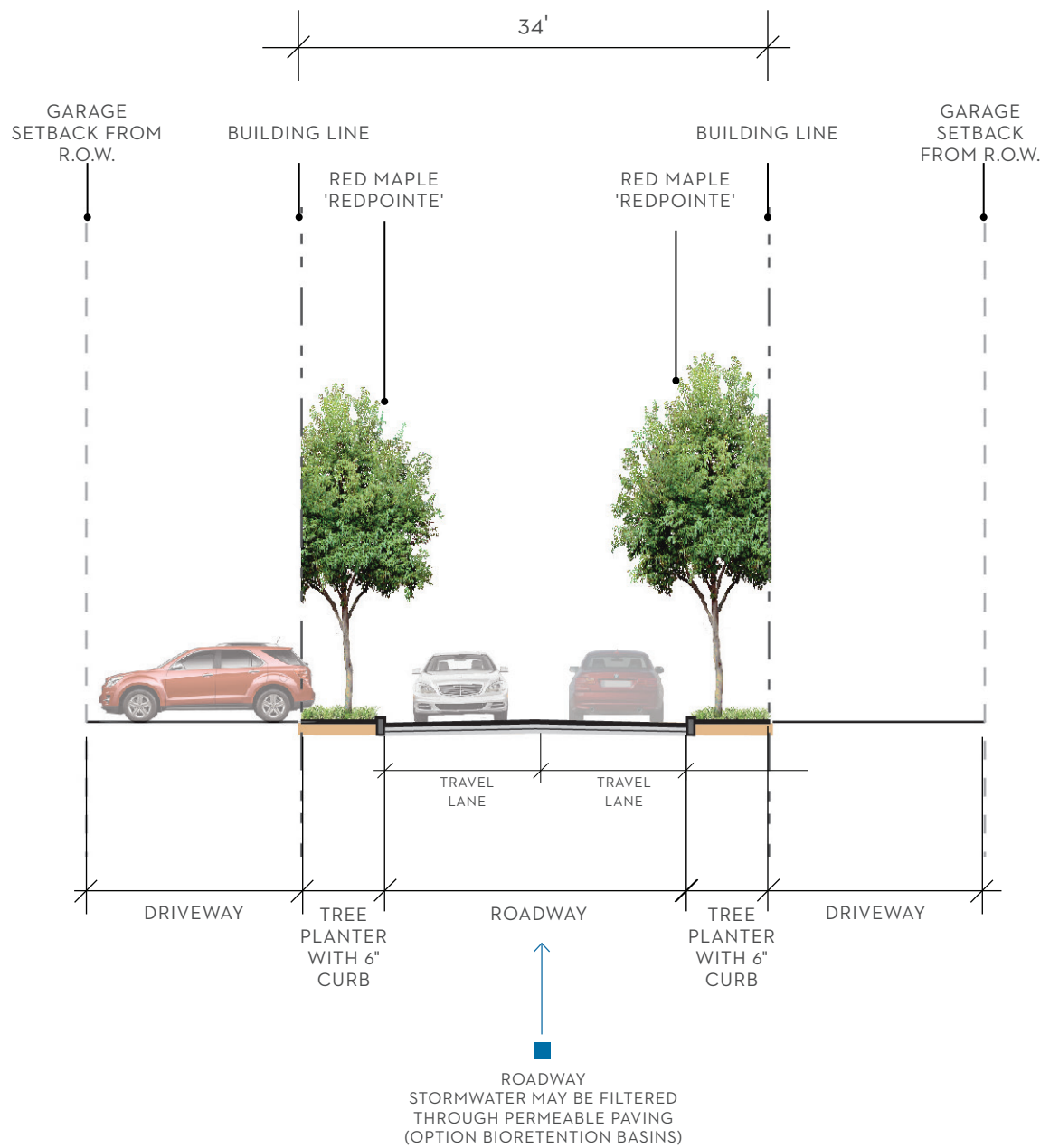


Brisbane Box

# TOWNHOME ALLEY 'TYPICAL'



# GARDEN COURT 'TYPICAL'



# Neighborhood Streetscape

## Proposed Plant List

Botanical Name	Common Name	Native	Size/ Foliage Character								Fall Color	Wildlife Forage
			Large Deciduous Trees >30'	Large Evergreen Trees > 30'	Small Deciduous Trees <30'	Small Evergreen Trees <30'	Large Deciduous Shrubs >4'	Large Evergreen Shrubs >4'	Small Deciduous Shrubs <4'	Small Evergreen Shrubs <4'		
<b>Trees</b>												
<i>Acer buergeranum</i>	Trident Maple				x							x
<i>Acer rubrum</i> 'Redpointe'	Red Maple		x									x
<i>Magnolia soulangiana</i> 'Alexandrina'	Saucer Magnolia											
<i>Platanus acerifolia</i> 'Yarwood' or 'Columbia'	London Plane		x									x
<i>Quercus agrifolia</i>	Coast Live Oak	x		x								x
<i>Sequoia sempervirens</i> (Parks only)	Coast Redwood	x										
<i>Tristania laurina</i>	Brisbane Box											
<i>Tristania laurina</i> 'Elegant'	Elegant Brisbane Box					x						
<i>Ulmus Japonica</i> + <i>U. Wilsoniana</i>	Accolade Elm		x									x
<b>Shrubs</b>												
<i>Arbutus unedo</i> 'Compacta'	Compact Strawberry Tree								x			x
<i>Arctostaphylos densiflora</i> 'Howard McMinn'	Vine Hill Manzanita	x							x			
<i>Arctostaphylos densiflora</i> 'Lutsko's Pink'	Manzanita	x							x			
<i>Arctostaphylos hookeri</i> 'Wayside'	Monterey Manzanita	x									x	
<i>Ceanothus</i> 'Dark Star'	Dark Star Wild Lilac	x							x			
<i>Ceanothus</i> 'Julia Phelps'	Julia Phelps Lilac	x							x			
<i>Cercis occidentalis</i>	Western Redbud	x						x				x
<i>Heteromeles arbutifolia</i>	Toyon											
<i>Mahonia</i> 'Golden Abundance'	Oregon Grape											
<i>Phormium</i> spp.	Flax	x							x			
<i>Rhamnus</i> 'Mound San Bruno'	Mound San Bruno Coffeeberry											x
<i>Rhamnus californica</i> 'Eve Case'	Eve Case Coffeeberry	x							x			
<i>Rhamnus californica</i> 'Seaview'	Seaview Coffeeberry	x							x			
<i>Rhamnus californica</i> 'Leatherneck'	Leatherneck Coffeeberry	x										x
<i>Rosmarinus</i> spp.	Rosemary	x							x			
<i>Salvia leucantha</i>	Mexican Bush Sage	x										

# Neighborhood Streetscape

## Proposed Plant List

Botanical Name	Common Name	Native
<b>Ground Covers, Perennials and Grasses</b>		
<i>Anigozanthos cultivars (dwarf)</i>	Kangaroo Paws	
<i>Arctostaphylos 'Emerald Carpet'</i>	Emerald Carpet Manzanita	x
<i>Arctostaphylos edmundsii 'Carmel Sur'</i>	Carmel Sur Manzanita	x
<i>Arctostaphylos uva-ursi 'Point Reyes'</i>	Point Reyes Manzanita	x
<i>Berberis 'Crimson Pygmy'</i>	Berberis	
<i>Calamagrostis foliosa</i>	Pacific Reed Grass	x
<i>Ceanothus gloriosus exaltatus 'Valley Violet'</i>	Wild Lilac	x
<i>Cotoneaster 'Lowfast' and 'Coral Beauty'</i>	Cotoneaster	
<i>Echium fastuosum</i>	Pride of Madeira	
<i>Eriogonum fasciculatum</i>	California Buckwheat	x
<i>Erisimum linifolium 'Bowles Mauve'</i>	Wallflower	
<i>Festuca mairei</i>	Atlas Fescue	
<i>Festuca 'Molate'</i>	Molate Fescue	x
<i>Festuca 'Siskiyou Blue'</i>	Fescue	x
<i>Lavandula angustifolia</i>	English Lavender	
<i>Lavandula ang. Hidcote Improved</i>	Hidcote Lavender	
<i>Myoporum parvifolium 'Putah Creek'</i>	Creeping Myoporum	
<i>Pennisetum spathiolatum</i>	Slender Veldt Grass	
<i>Ribes viburnifolium</i>	Catalina Fragrance	x
<i>Rosmarinus 'Huntington Carpet'</i>	Huntington Carpet Rosemary	
<i>Teucrium chamaedrys dwarf</i>	Dwarf Germander	



## 4.3 OPEN SPACE DESIGN

The open space network consists of a range of open spaces including existing undisturbed open space, the restored Rifle Range Creek Corridor, revegetated hillsides and publicly accessible neighborhood parks.

- The existing grassland on the upper hillside and areas of existing preserved oak woodland are protected natural resources.
- The lower hillside will be extensively planted as a restored oak woodland natural setting, consisting of several native oak species, Toyon and California Buckeye.
- The restored Rifle Range Creek will be revegetated with an appropriate and diverse native plant community to recreate a natural setting that benefits wildlife, and includes a multi-use trail serving the community. Refer to the Oak Knoll Mixed Use Community Development Project Regulatory Permit Application Package.
- Tree mitigation occurs site-wide in a variety of locations. Refer to the Tree Removal Permit Package for recommended mitigation locations and species.



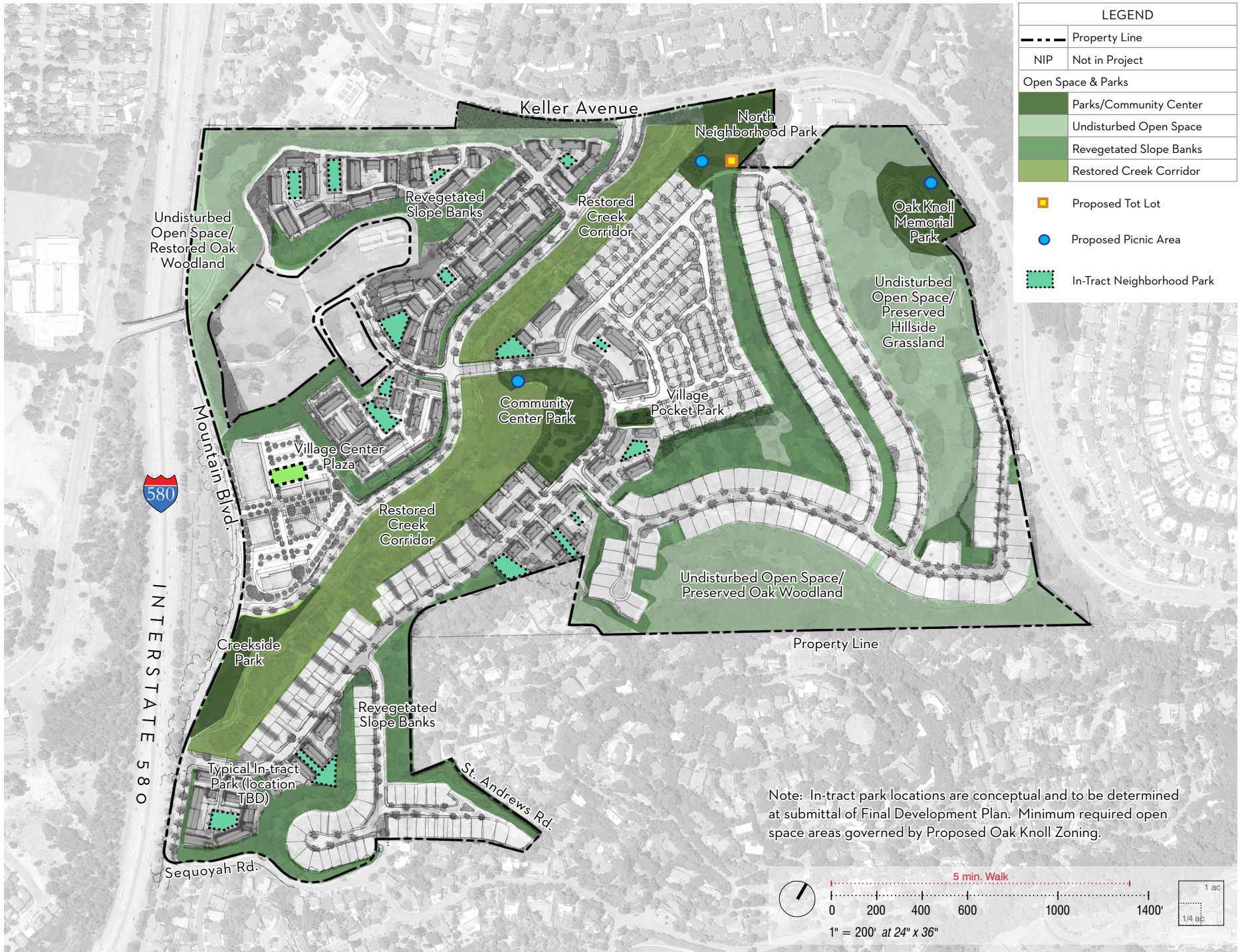


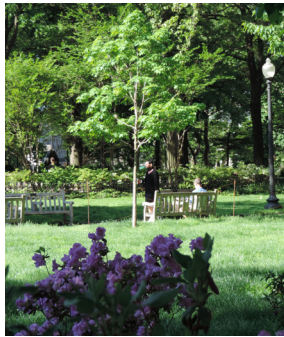
Figure 4.2- Open Space and Parks

## 4.4 PARKS AND PLAZA DESIGN INTENT

There are three kinds of public parks offering active and passive recreational opportunities as described in the PDP. Larger more active community parks (see Figure 4.2) include the park areas at the Club Knoll community center and the neighborhood park near the project's northern boundary. Smaller more passive neighborhood parks are planned near the Community Center and within the townhome in-tract parcels. The plaza at the retail Village Center will serve as a social gathering and event space for the community, with decorative hardscape, benches, informal seating and canopy shade trees. Landscape guidelines for parks and plazas include:

- The parks should emphasize use of native trees, shrubs, and groundcovers in both organic and formal settings. Refer to the Neighborhood Streetscape Plant List for Proposed Plants.
- Parks should incorporate community-wide furnishings and signage consistent with other design elements in the community.
- Parks should provide shaded seating areas, picnic tables, and trash receptacles.
- Hardscape areas should avoid asphalt and large expanses of concrete. Natural stone, pavers, high quality stamped concrete, and decomposed granite should be utilized in the appropriate settings.
- A tot lot with play structures and picnic benches and lawn areas will be located at two locations and should include play equipment that is durable, safe, appropriately scaled, shaded and maintainable.
- Recreation areas such as playfields and multi-use courts should employ high quality turf and/or hardscape surfaces. Site drainage shall be extensively utilized on playfields and other higher impact natural areas.
- All fencing should be natural in character and follow these design guidelines, see Appendix B.
- Parks should provide connections and wayfinding to the project-wide trail and bikeway system.
- Where public art is included in park settings, designers should coordinate with artists prior to park design to ensure art elements are well integrated, accessible and compliment other elements of the park design.

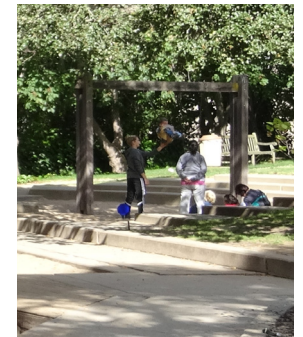
COMMUNITY PARK



RETAIL VILLAGE



NEIGHBORHOOD PARKS



## 4.5 COMMUNITY TRAILS AND RECREATION

An extensive network of trails extend throughout the community, affording a range of experiences, challenges levels and activity options, including running, hiking, walking, dog walking and accessibility.

- Emphasis is on use of natural materials and simple treatments that are intended to integrate fully with the natural setting.
- Use of reclaimed timber for benches, signage, and trail markers with opportunities to incorporate hand-crafted artisan designs.

Trails for Oak Knoll are classified as follows:

- Hiking Trails
- Multi-Use Path (Walking/ Running/Biking)
- Neighborhood Path
- Bike Route

Location of the trails systems should meet the following design objectives:

- Safety
- Connectivity to on-site and off-site destinations
- Diversity in experiences and user types
- Conforms to site attributes, opportunities and constraints



Wayfinding Sign



Trailhead Signage



Bay View telescope at Vista Point



Soil cement surface



Unique wood benches

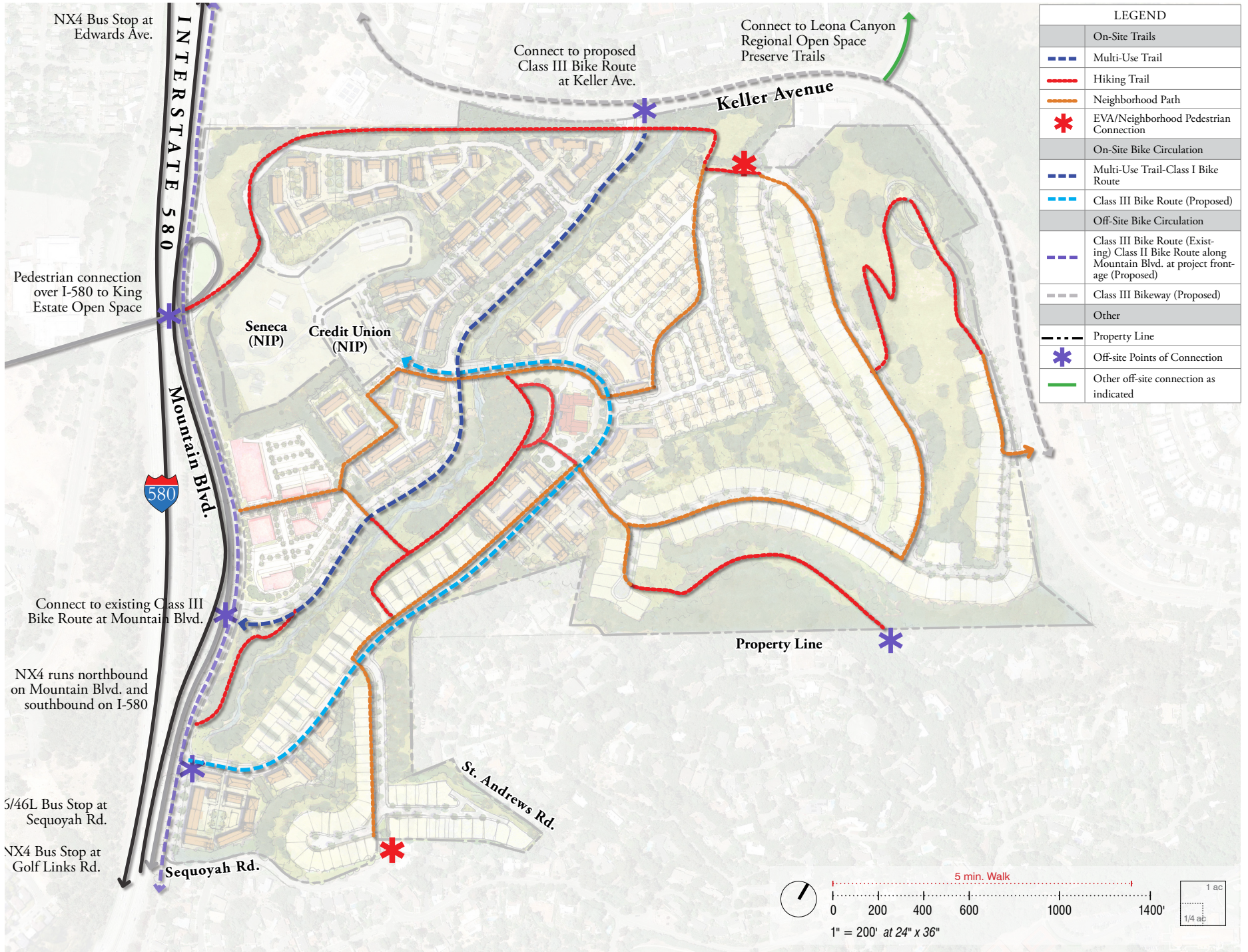


Figure 4.3- Bike and Pedestrian Trails and Connections

## 4.6 SIGNAGE AND MONUMENTATION

Stone piers with historic details are envisioned for use to celebrate the main entry points and secondary neighborhood entry points. A hierarchy of scale will differentiate the entry and neighborhood monuments, while incorporating unique details and establishing a common approach. Materials and craftsmanship will employ a unified approach to unify the community design, including stone details at the vehicular bridge crossing the creek and community center entrance.

The vision for the main entry monument on Mountain Boulevard and Keller Avenue is for a collection of native trees (oaks, manzanita, etc) in a naturalized composition with stone piers marking the entry. Community signage may be integrated into the piers similar to the tradition of the neighborhood street names at neighborhood entries.



Community Entry Monument Concept



Stone Neighborhood Entry Piers



Community Entry Conceptual Plan - Mountain Boulevard and Creekside Parkway (NTS)



Figure 4.4 - Signage and Monumentation Plan



## 4.7 WALLS

### SITE RETAINING WALLS

Retaining walls will be needed due to the sloping topography of the site. See the Appendices for Approved Retaining Wall. Low shrubs are required where space between the face of retaining walls and right of way or swale exceeds 2'. Retaining walls greater than 4' tall require top of wall planting, Retaining walls greater than 6' tall shall have vines planted on the face of walls in drifts of single species; each drift of vine planting should not exceed 50' before blending into another species.

Retaining walls taller than 30" shall incorporate a 42" guardrail. See figure and detail in Appendix B. Fences shall be set behind the top of wall (or top of wall swale where occurs) 4' to allow for shrub massing.

The Approved Plants include the following:

Vines for Retaining Walls (plant on face in drifts of single species, 8' spacing to achieve 50% cover when mature):

- Parthenocissus tricuspidata 'Veitchii'/Dwarf Boston Ivy
- Solanum rantonetti/Potato vine

Shrub massing for base of walls, where planting area (clear of drainage swales) measures 2'-4':

- 40% Ceanothus gloriosus 'Valley Violet'/Valley Violet Wild Lilac
- 40% Westringia fruticosa 'Grey Box' or 'Jervis Gem'
- 20% Erysimum Bowle's Mauve'

Shrub massing for base of walls (clear of drainage swales) where planting area measure 4' to 10':

- 40% low shrub massings:
- Ceanothus maritimus cultivars planted in drifts alternating with Manzanita:
- "Frosty Dawn", 'Valley Violet' and/or 'Point Sierra'
- 30% Arctostaphylos hookeri 'Wayside'
- 30% Feijoa sellowiana/Pineapple Guava (taller shrub massings where walls exceed 7 feet)

The Approved Site Retaining Wall is:

- Pavestone 'Anchor Diamond Pro' Retaining Wall
- Face Style: Straight
- Color: Sandstone Blend



Vines planted on face of retaining wall

## 4.8 RESIDENTIAL LANDSCAPE DESIGN

The following principles embedded in the landscape design philosophy closely mirror the architectural design principles:

- Oak Knoll landscapes and gardens are versatile, imaginative and offer a range of expressions.
- Landscapes encourage a relaxed, informal and practical approach while accommodating contemporary lifestyles.
- Landscapes are designed to respond to unique characteristics, such as lot configuration, topography, existing vegetation, and the design and location of the house and ancillary structures.

Residential landscaping will be the responsibility of the individual Homeowners and Builders and shall be thoughtfully designed according to these guidelines. A palette of plant and landscape materials is established in these guidelines to ensure visual unity within visible lot areas while allowing room for individual creative design solutions.

## 4.9 SINGLE FAMILY RESIDENTIAL

Landscape guidelines and requirements within this Section address unique landscape conditions that occur for the single family residential lots found at Oak Knoll.

### OBJECTIVES

- Integrate the built environment with a dominant landscape.
- Blend landscapes between lots and neighborhood streets as a unified community landscape setting.
- Establish a healthy, sustainable and natural landscape environment.
- Prioritize front yard landscapes to reinforce neighborhood streets as livable, walkable places. The combination of front porches and front yard gardens within the private frontages activate the streetscape, and shall contribute to a consistent, high quality neighborhood landscape.
- Low groundcovers have low water requirements and are composed in drifts, using selections from the Approved Plant (see Appendices).

Three general landscape zones have been defined for each home site. Objectives and guidelines regarding landscaping, planting, paving, walls and fencing within each zone are described in this chapter. The three landscape zones are described as follows:

### FRONT YARD ZONE

The front yard is defined by the area between the front property line and the front face of the building, extending to the side property lines. The objectives within this zone are to reinforce and enrich the neighborhood street scene and to provide a transition from the street to the private landscape. All plantings within this zone are to occur prior to home occupation.

### SIDE YARD ZONE

The side yard areas maintain privacy for indoor and outdoor living spaces while also providing access around the home. A range of creative solutions such as using architectural site walls and fences combined with neat vertical plantings and groundcovers are encouraged. Sensitivity to neighboring lots is required in the design of side yards in order to avoid blocking light or creating maintenance and nuisance issues, while protecting for privacy.

### REAR YARD ZONE

This area is defined as the area between the rear property line and the rear face of the building, extending to the side property lines. The objective within this zone is to provide privacy, pleasant outdoor living spaces and shade for building western exposures. Sensitivity to neighboring lots is required in the design of the rear yard areas in order to avoid blocking light or creating maintenance and nuisance issues.

Refer to Figure 4.5- Typical Home Site Planting Diagram for planting requirements for each zone.

Required Rain Garden at Front and Rear Yard (60 square feet Minimum)

Required (1) Small Tree at Front Yard

Required (1) 15 gal. Medium Tree and (1) 15 gal. Small Tree at Rear Yard

Required Foundation Planting at Porches

Required Street Tree per Final Development Plan



## PLANTING PALETTE

### Small Trees

(4) 15 gallon total

- Arbutus unedo/Strawberry Tree (compact form)
- Magnolia x s. 'Lilliputian'/ Saucer Magnolia (dwarf form)

### Medium Trees

(1) 15 gallon total

- Quercus agrifolia/Coast Live Oak
- Arbutus 'Marina'/ 'Marina' Madrone

### Planting Type 1

(perennials, low shrubs and groundcover)

Lavandula angustifolia 'Hidcote'/English Lavender (dwarf cultivars) qty:10

- Arctostaphylos 'Point Reyes'/Manzanita
- Ceanothus gloriosus 'Frosty Dawn'/Wild Lilac
- Rhamnus 'Seaview'/Seaview Coffeeberry
- Festuca rubra 'Molate'/Creeping Red Fescue

### Planting Type 2

(rain garden grasses/perennials, accent taller shrubs and fence vine)

- Festuca rubra 'Molate'/Creeping Red Fescue
- Ribes sanguineum/Pink winter Currant
- Pacific Coast Iris cultivars
- Hardenbergia comptoniana/Lilac Vine

### Planting Type 3

(lawn, meadow grasses, groundcovers and low shrubs)

- Dwarf Tall Fescue lawn sod or seed
- Carex pansa/California Meadow Sedge pots or plugs
- Calamagrostis foliosa/Feather Reed Grass
- Rhamnus 'Leatherneck'/Coffeeberry

Figure 4.5: Typical Home Site Planting Diagram

## FRONT YARDS ON SLOPED LOTS

Lots located on streets with slopes greater than 10% shall be completely vegetated and may use a combination of low walls and plantings to achieve changes in grade. Plants that aid in erosion control are recommended.

### GUIDELINES

- Front yard slopes may not exceed 2:1.
- Retaining walls, if used, should be terraced where possible and not exceed a maximum height as set forth in the Zoning Ordinance.
- Retaining walls shall be integrated with shrub planting to soften and screen walls.

See Section 4.11 Retaining Walls on Lots for Approved Materials.



Sloped Lot Planting



Combination of Planting and Retaining Walls at Sloped Lots

## 4.10 SIDE AND REAR YARD FENCING

Side yard fencing is required for functional and safety reasons. All fencing shall use quality materials and follow the Approved Standard Fence Details in Appendix B.

### GUIDELINES

- All fencing may either slope with grades or adjust as a vertical offset between panels. Offsets shall not exceed 12 inches.
- All fencing between adjoining lots shall have a height of 6 feet. Corner lots and end lots are encouraged to reduce fence heights at side yards to allow views with a minimum height of 4 feet.
- All fencing shall be softened with flowering vines and shrubs to soften their visual appearance where visible from public areas.
- A few upper hillside home sites with sloped rear yards in excess of 20% shall utilize the Approved Hillside Fence in the rear yard.
- Lots with pools and spas require fencing and gates that meet all applicable codes.
- Typical side and rear yard fencing is a solid cedar or redwood fence with a stained finish.
- For upland lots with rear yards with onsite and offsite visibility, rear yard fencing, if used, shall use the Approved Hillside Fence to ensure visual consistency.
- For lots with side or rear yards that front on the creek corridor, a neighborhood park or open space, please refer to appropriate wall design examples in Appendix B.



Typical Side Yard Board-on Batten Style Privacy Fence



Typical Hillside Fence where slopes exceed 20% (stepped or sloping rear yard conditions)

## 4.11 RETAINING WALLS ON LOTS

Retaining walls may be needed due to sloping topography on individual lots. Retaining walls shall be minimized and designed to fit the topography. Retaining walls in the side or rear yard shall use the Approved Retaining Wall design shown in the Appendices.

### GUIDELINES

- Use of stucco, brick, painted brick or natural stone veneer may be used for site walls in front and side yards that are visible from public areas. Materials shall complement the building architecture.
- Wall heights shall be appropriate to context and shall not exceed 6' in height per Code.
- Tiered walls shall be integrated landscape design.
- Tops of walls may either slope or step with the topography as required. Walls may slope at 1:8 maximum or use vertical offsets of 12" maximum.
- Use of vines, trailing evergreen groundcovers and shrub massings are encouraged to soften walls.
- Retaining walls in side and rear yards- Walls not closely associated with the architecture and not visible from public areas may use the Approved Standard Wall System described in the Appendices.
- Retaining walls in rear yards shall be located a minimum of 4' from the property line to allow room for fencing.
- Retaining walls and steps at front walkways are allowed to resolve site grading.

- The following retaining wall materials are allowed:
  - Brick
  - Painted brick
  - Natural stone veneer
  - Approved concrete block wall system in rear and side yards (refer to Appendices)
  - Gabions
  - Pressure-treated wood
- The following retaining wall materials are **not** allowed:
  - Railroad ties
  - Metal cribs
  - Concrete pylons



# APPENDICES



# APPENDIX A

The following colors and materials have been assembled to give developers guidance. They are intended to communicate the vision of the Oak Knoll character. Nonetheless, creativity is encouraged, and alternatives to these materials, which adhere to the spirit of these guidelines will be considered by the DRC. A more detailed and design-specific palette of colors and materials shall accompany all FTP applications and be reviewed by the DRC.

APPENDIX A - APPROVED MATERIALS & COLOR PALETTE

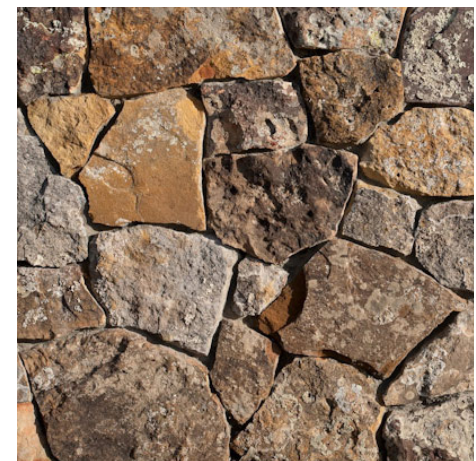
**ARCHITECTURAL BRICK (FACE BRICK) AND STONE  
VENEER PALETTE**



EXAMPLES OF ACCEPTABLE BRICK FINISHES



EXAMPLES OF ACCEPTABLE STONE VENEER FINISHES



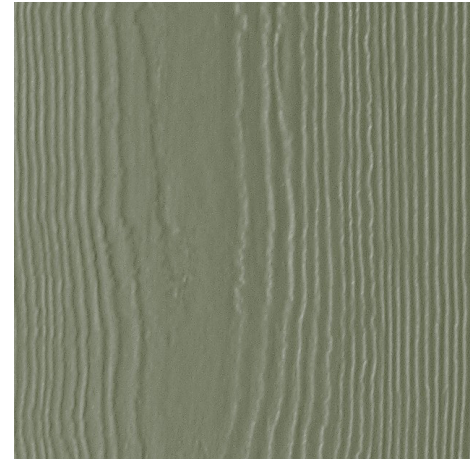
ARCHITECTURAL SIDING AND ROOF PALETTE



STAINED OR PAINTED SHINGLE SIDING



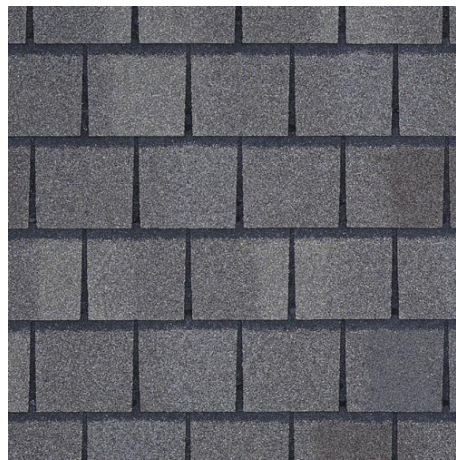
STAINED OR PAINTED SHINGLE SIDING



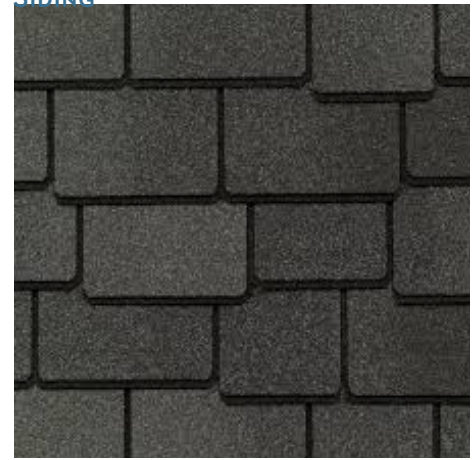
PAINTED WOOD OR WOOD COMPOSITE SIDING



CLAY TILE ROOF

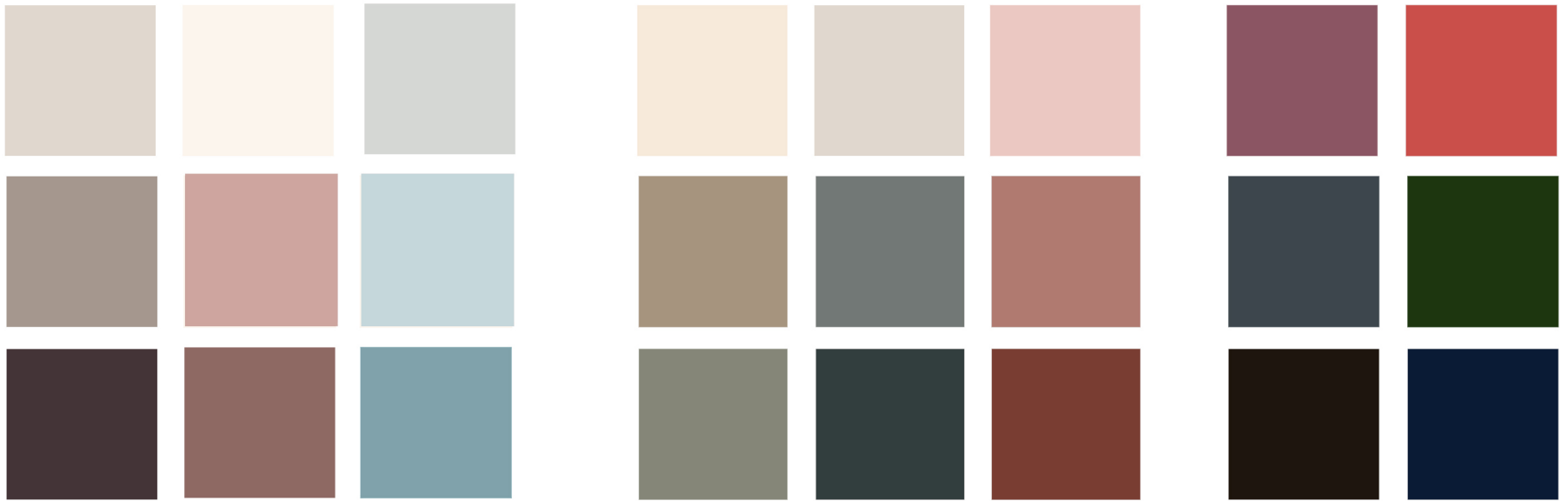


ASPHALT TILE ROOF - GRAY



ASPHALT TILE ROOF - BLACK

**ARCHITECTURAL PAINT COLORS**





# APPENDIX B

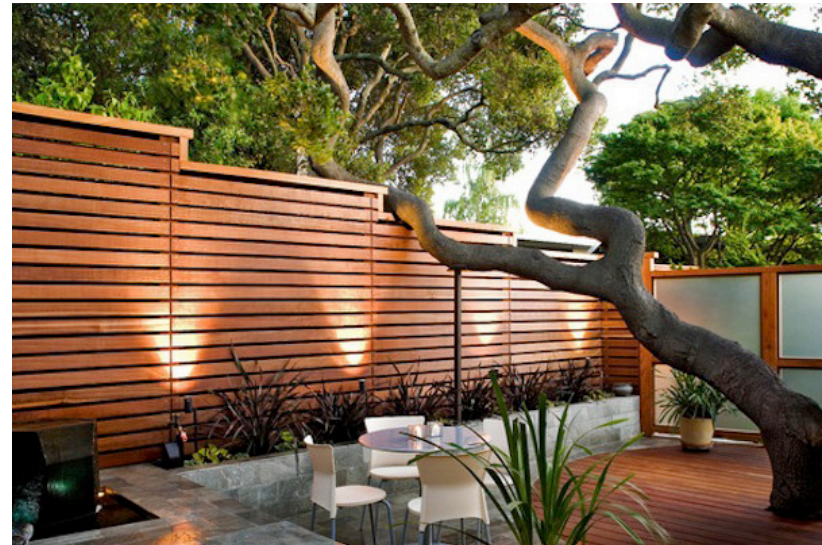
## APPROVED STANDARD RETAINING WALL SYSTEM ON LOTS

- 'Anchor Highland Stone Retaining Wall 6" Combo' (Product 876) by Pavestone, Inc. : 3 piece system, sizes 18"x12"x6", 12"x12"x6", and 6"x12"x6". Color to be determined. Cap #819. (<http://www.pavestone.com/anchor-highland-stone-retaining-wall-6-combo/>)

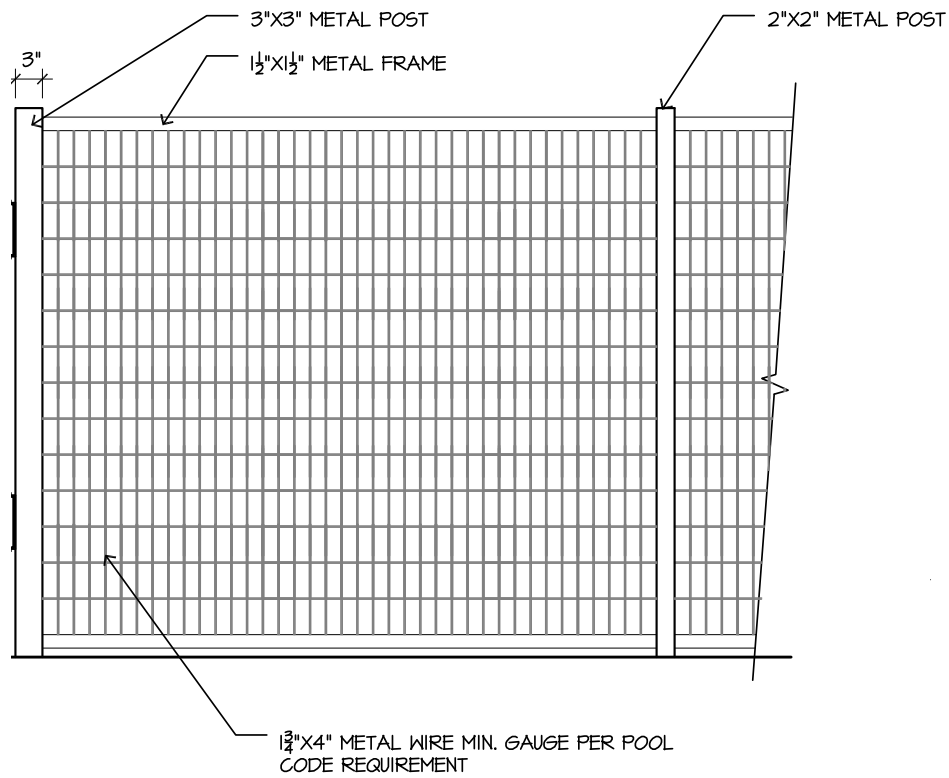


## STANDARD APPROVED SIDE YARD AND REAR YARD FENCES

- Minimum Standard Material: #1 grade Western Red Cedar or Redwood
- Stain finish: Cabot 'Red Cedar'
- Note: Both sides are finished equally
- 4x6 posts Western Red Cedar posts 6' apart
- Boards: 1x8, Battens: 1x3 (both sides), Cap: 1x6 with 1x4 facer
- Height: 6'-0"
- add low plants at base like a low grass or lirioppe



### STANDARD APPROVED GUARDRAIL





# APPENDIX C

The following Approved Plant List and Prohibited Plant List are intended to communicate the vision of the Oak Knoll landscape character. Nonetheless, creativity is encouraged, and alternatives to these materials, which adhere to the spirit of these guidelines will be considered.

APPENDIX C - APPROVED PLANT LIST

Botanical Name	Common Name	Street Trees	Large	Medium	Small	Native	Full Sun	Part Sun/Shade	Full Shade	Rain Garden
<b>TREES</b>										
<i>Acer buergeranum</i>	Trident Maple			x	x		x		x	
<i>Arbutus 'Marina'</i>	Madrone 'Marina'			x			x		x	
<i>Agonis flexuosa</i>	Peppermint Tree				x		x			
<i>Acer japonicum</i>	Japanese Maple			x			x		x	
<i>Lagerstroemia indica</i>	Crape Myrtle			x	x		x			
<i>Lepotospermum scoparium</i>	New Zealand Tea Tree				x		x	x		
<i>Magnolia grandifolia 'Little Gem'</i>	Dwarf Southern Magnolia				x		x	x		
<i>Magnolia soulangiana 'Lilliputian'</i>	Dwarf Saucer Magnolia				x		x	x		
<i>Ceanothus 'Ray Hartman'</i>	Ray Hartman Wild Lilac				x	x	x			
<i>Cercis occidentalis</i>	Western Redbud				x	x	x	x		
<i>Heteromeles arbutifolia</i>	Toyon				x	x	x	x		
<i>Arbutus unedo</i>	Strawberry Tree				x		x	x		
<i>Malus floribunda</i>	Crabapple				x		x	x		
<i>Citrus - dwarf cultivars</i>					x		x			
<i>Fruit Trees - dwarf cultivars</i>					x		x			

<b>SHRUBS</b>										
<i>Carpenteria californica</i>	Bush Anemone			x		x	x	x		
<i>Ceanothus spp.</i>	Wild Lilac		x			x	x			
<i>Camelia sasanqua</i>	Apple Blossom		x				x	x	x	
<i>Chondropetalum tectorum</i>	Cape Rush					x				x
<i>Ribes sanguineum</i>	Pink Flowering Currant			x		x	x	x		
<i>Loropetalum chinense</i>	Fringe Flower					x				
<i>Hebe species</i>	Hebe			x	x		x	x		
<i>Mahonia aquifolium</i>	Oregon Grape		x			x	x	x		
<i>Phormium spp. (dwarf cultivars)</i>	Flax			x	x		x	x		
<i>Rhamnus californica cultivars</i>	Coffeeberry		x			x	x	x		
<i>Podocarpus gracilior</i>	Fern Pine			x		x	x			
<i>Viburnum suspensum</i>	Sandankwa Viburnum		x				x	x		

Botanical Name	Common Name	Street Trees							Notes
		Large	Medium	Small	Native	Full Sun	Part Sun/Shade	Full Shade	
<b>GROUNDCOVERS, PERENNIALS AND GRASSES</b>									
<i>Anigozanthos flavidus</i>	Kangaroo Paws		x	x		x			
<i>Arctostaphylos 'Emerald Carpet'</i>	'Emerald Carpet' Manzanita			x	x	x			
<i>Arctostaphylos edmundsii 'Carmel Sur'</i>	'Carmel Sur' Manzanita			x	x	x			
<i>Arctostaphylos uva ursi 'Pt. Reyes'</i>	'Pt. Reyes' Manzanita			x	x	x	x		
<i>Berberis 'Crimson Pygmy'</i>	Burberry			x		x	x		
<i>Calamagrostis foliosa</i>	Pacific Reed Grass			x	x	x			
<i>Ceanothus griseus horizontalis</i>	Wild Lilac			x	x	x	x		
<i>Ceanothus gloriosus</i>	Point Reyes Ceanothus			x	x	x	x		
<i>Ceanothus 'Hearts Desire'</i>	Heart's Desire Ceanothus			x	x	x	x		
<i>Ceanothus 'Centennial'</i>	Centennial Lilac			x	x	x	x		
<i>Cotoneaster dammeri Lowfast' and 'Coral Beauty'</i>	Cotoneaster			x		x	x		
<i>Dymondia margaratae</i>	Dymondia			x		x	x		
<i>Erigeron species</i>	Seaside Daisy					x			
<i>Festuca rubra 'Molate'</i>	'Molate' Red Fescue			x	x	x	x	x	
<i>Festuca 'Siskiyou Blue'</i>	Fescue			x		x	x		
<i>Lavandula angustifolia 'Munstead'</i>	English Lavender			x		x			
<i>Lavandula ang. 'Hidcote Improved'</i>	'Hidcote' Lavender			x		x			
<i>Myoporum parvifolium</i>	Creeping Myoporum			x		x	x		
<i>Teucrium chamaedrys 'Nanum'</i>	Dwarf Germander			x		x			
<i>Iris PCH 'Canyon Snow'</i>	Pacific Coast Iris			x	x	x	x		
<i>Euphorbia characias</i>	Euphorbia		x			x			
<i>Lessingia filaginifolia 'Silver Carpet'</i>	Silver Carpet Beach Aster			x	x	x			
<i>Carex testacea</i>	New Zealand Sedge		x			x			
<i>Libertia grandiflora</i>	New Zealand Iris			x		x	x		
<i>Festuca glauca</i>	Blue Fescue			x	x	x			
<i>Agrostis pallens</i>	Bent Grass			x	x	x			Lawn substitute
<i>Carex pansa</i>	California Meadow Sedge			x	x	x			Lawn substitute
<i>Sesleria autumnalis</i>	Autumn Moor Grass			x	x	x			
<i>Carex divulsa</i>	Berkeley Sedge		x		x	x		x	
<i>Carex praegracilis</i>	Western Meadow Grass			x	x	x		x	
<i>Achillea spp.</i>	Yarrow		x			x			

APPENDIX C - APPROVED PLANT LIST

Botanical Name	Common Name	Street Trees								Notes
		Large	Medium	Small	Native	Full Sun	Part Sun/Shade	Full Shade	Rain Garden	
<b>GROUNDCOVERS, PERENNIALS AND GRASSES</b>										
<i>Aeonium</i> spp.	Canary Island Rose			x		x	x			
<i>Baccharis pilularis</i> 'Pigeon Pt.'	Dwarf Coyote Bush			x	x	x	x			
<i>Dietes</i> species	Fortnight Lily		x			x	x			
<i>Penstemon</i> spp.	Penstemon		x	x	x	x	x			
<i>Salvia greggii</i>	Salvia		x	x		x	x			
<i>Stachys byzantina</i>	Lamb's Ears			x	x	x	x			
<i>Zauschneria</i> spp.	California Fuchsia			x	x	x	x			
<i>Helictotrichon sempervirens</i>	Blue Oat Grass			x		x				
<i>Geranium</i> spp.	Geranium			x		x	x			
<i>Lantana sellowiana</i>	Lantana			x		x				
<i>Juncus patens</i>	California Gray Rush		x	x	x	x	x		x	
<i>Liriope muscari</i>	Lily Turf			x		x	x			
<i>Libertia peregrinans</i>	New Zealand Iris			x		x				

Botanical Name	Common Name	Street Trees								Notes
		Large	Medium	Small	Native	Full Sun	Part Sun/Shade	Full Shade	Rain Garden	
<b>VINES</b>										
<i>Clytostoma callistegioides</i>	Lavendar Trumpet vine					x	x			
<i>Ficus repens</i>	Creeping Fig					x	x			
<i>Hardenbergia violacea</i>	Lilac Vine					x	x			
<i>Mandevilla laxa</i>	Chilean Bower Vine					x	x			
<i>Rosa</i> spp.	Roses					x	x			
<i>Solanum jasminoides</i>	Potato Vine					x	x			
<i>Vitis californica</i>	California Grape				x	x	x			
<i>Calystegia macrostegia</i>	Coastal Morning Glory				x	x				
<i>Jasminum polyanthum</i>	Pink Jasmine					x	x			
<i>Gelsemium sempervirens</i>	Carolina Jessamine					x	x			
<i>Pandorea jasminoides</i>	Bower Vine					x	x			

## PROHIBITED PLANT LIST

The following list of invasive species are prohibited. As information is constantly changing, this list may be updated from time to time. This list is derived from Cal-IPC.

Latin binomial / Common names

Acacia dealbata / Silver wattle  
Acacia melanoxylon / Blackwood acacia  
Acanthus mollis / Bears breech  
Agapanthus spp. / Lily of the Nile  
Ailanthus altissima / Ailanthus, Tree-of-heaven  
Albizia julibrissen / Silk floss  
Alhagi maurorum / Camelthorn  
Aptenia cordifolia / Red apple, Baby sun rose  
Arcotroche calendula / Capeweed, Cape dandelion  
Arundo donax / Giant reed, Giant cane  
Atriplex semibaccata / Australian saltbush  
Avena barbata / Slender oat  
Avena fatua / Wild oats  
Bassia hyssopifolia / Five-hook bassia, Thorn orache  
Bellardia trixago / Bellardia, Mediterranean linseed  
Brassica spp. / Mustards  
Bromus madritensis ssp. rubens / Foxtail chess  
Bromus tectorum / Cheatgrass, Downy brome  
Cardaria chalepensis / Lens-podded hoary cress  
Cardaria draba / Heart-podded hoary cress, White-top  
Cardaria pubescens / Hairy whitetop  
Carduus spp. / Thistles  
Carpobrotus edulis / Highway iceplant  
Centaurea spp. / Hardheads, Knapweed

Centranthus rubra / Valerian  
Cirsium spp. / Thistles  
Cistus ladanifer / Crimson spot rock rose  
Conicosia pugioniformis / Narrow-leafed iceplant  
Conium maculatum / Poison hemlock  
Cortaderia spp. / Pampasgrass  
Cotoneaster spp. / Cotoneaster  
Crataegus monogyna / Singleseed hawthorn  
Cynara cardunculus / Artichoke thistle, Cardoon  
Cytisus spp. / Broom  
Delairea odorata / Cape ivy, German ivy  
Digitalis purpurea / Foxglove  
Dimorphotheca sinuata / African daisy  
Drosantemum spp. / Ice plant  
Echium candicans, E. fastuosum / Pride-of-Madeira  
Egeria densa / Brazilian egeria  
Ehrharta spp. / Veldtgrass  
Eichhornia crassipes / Water hyacinth  
Elaeagnus angustifolia / Russian olive, Oleaster  
Elaeagnus pungenis / Silverberry  
Erechtites spp. / Fireweed  
Eucalyptus camaldulensis / Red gum  
Eucalyptus globulus / Bluegum  
Euphorbia spp. / Spurge  
Festuca arundinacea / Tall fescue  
Ficus carica / Edible fig, Common fig  
Foeniculum vulgare / Fennel, Sweet anise  
Gazania linearis / Gazania  
Genista spp. / Broom  
Halogeton glomeratus / Halogeton  
Hedera helix / English ivy

APPENDIX C - APPROVED PLANT LIST

Hedera canariensis / Algerian ivy  
Helichrysum petiolare / Licorice plant  
Holcus lanatus / Common velvet grass  
Hydrilla verticillata / Hydrilla, Water thyme  
Hypericum spp. / St. John's Wort  
Ilex aquifolium / English holly  
Iris pseudacorus / Yellow flag iris  
Juniperus spp. / Juniper  
Lampranthus spp. / Ice plant  
Lepidium latifolium / Perennial pepperweed  
Leucanthemum vulgare / Ox-eye daisy  
Ligustrum lucidum / Glossy privet  
Ludwigia hexapetala / Creeping water primrose  
Ludwigia peploides / California water primrose  
Lythrum hyssopifolium / Hyssop loosestrife  
Lythrum salicaria / Purple loosestrife  
Malephora spp. / Ice plant  
Marrubium vulgare / Horehound  
Maytenus boaria / Mayten  
Mentha pulegium / Pennyroyal  
Mesembryanthemum spp. / Iceplant  
Myoporum laetum / Ngaio tree  
Myriophyllum aquaticum / Brazilian watermilfoil  
Myriophyllum spicatum / Spike watermilfoil  
Nandina spp. / Bamboo  
Olea spp. / Olive  
    \*Except Fruitless cultivar 'Swan Hill'  
Pennisetum spp. / Fountain grass  
Pistacia chinensis / Chinese pistache  
    \*Except Fruitless cultivar 'Keith Davey'  
Phalaris aquatica / Harding grass  
Pittosporum spp. / Mock orange  
Platanus acerifolia / Bloodgood plane tree  
Pyracantha spp. / Firethorn  
Retama monosperma / Bridal veil broom  
Ricinus communis / Castor bean  
Robinia pseudoacacia / Black locust  
Rubus armeniacus / Himalayan blackberry  
Saponaria officinalis / Bouncing bet  
Schinus terebinthifolius / Brazilian pepper tree  
Schismus spp. / Mediterranean grass, Arabian grass  
Senecio jacobaea / Tansy ragwort, Ivy  
Sesbania punicea / Scarlet wisteria  
Silybum spp. / Thistles  
Spartina spp. / Cord grass, Marsh grass  
Spartina patens / Salt marsh hay  
Stipa manicata / Tropical needlegrass  
Taeniatherum caput-medusae / Medusahead  
Tamarix parviflora / Tamarisk, Saltcedar  
Ulex europaeus / Common gorse  
Verbena bonariensis / Tall vervain  
Verbascum spp. / Mullein  
Vinca spp. / Periwinkle  
Zantedeschia aethiopica / Calla lily

**Appendix G**  
Revised Transportation  
Demand Management (TDM)  
Plan (December 2016)

# **Draft Transportation Demand Management Program for the Oak Knoll Project**

Prepared for:  
Oak Knoll Venture Acquisition  
City of Oakland

December 2016

OK14-0026

FEHR  PEERS





## Table of Contents

<b>INTRODUCTION AND PROJECT OVERVIEW.....</b>	<b>1</b>
Project Overview .....	1
Mixed-Use Development .....	1
Complete Streets Plan .....	2
<b>TDM PROGRAM GOALS AND STRATEGIES .....</b>	<b>5</b>
TDM Program Goals .....	5
Proposed TDM Strategies .....	5
Additional TDM Strategies.....	9
<b>MONITORING, EVALUATION AND ENFORCEMENT.....</b>	<b>11</b>

## Appendices

Appendix A: City of Oakland Standard Condition of Approval for TDM

## List of Tables

Table 1 Project and Proposed TDM Program Components That Reduce Vehicle trips .....	7
---	---

## INTRODUCTION AND PROJECT OVERVIEW

This Draft Transportation Demand Management (TDM) program is for the proposed Oak Knoll Project, which would consist of residential and commercial uses in southeast Oakland. The Project's proposed TDM strategies are presented in this Plan. The TDM program was prepared in accordance with the City of Oakland's Standard Conditions of Approval (SCA), which is presented in **Appendix A**.

### PROJECT OVERVIEW

The Project is located in southeast Oakland in a suburban environment approximately four miles from the nearest BART/Amtrak station (the Oakland Coliseum Station). The Project would consist of the following:

- 363 single-family homes,
- 572 townhomes,
- 72,000 square feet of commercial development,
- 4,000 square feet of community center, and
- 10,000 square feet of additional commercial space for the redeveloped Club Knoll.

The Project site is currently mostly vacant, except for Club Knoll, which will be moved to another location on the Project site as part of the Project. The Seneca School and Credit Union buildings are nearby, but are not part of the Project site.

According to the Draft Supplemental Environmental Impact Report (DSEIR) prepared for the Project, the proposed Oak Knoll Project is estimated to generate 642 AM peak hour, 1,149 PM peak hour, and 12,360 daily automobile trips. The Project is also estimated to generate about 1,600 pedestrian, 170 bicycle and 770 transit daily trips.

### MIXED-USE DEVELOPMENT

As described above, the Project would consist of 935 residential units and 82,000 square feet of commercial uses. The mixed-use characteristics of the Project would reduce the external automobile trips (e.g., trips with an origin or destination outside the Project site) generated by the Project since Oak Knoll residents are expected to utilize the commercial uses on-site. Because co-locating retail (in particular, grocery stores) with residential uses is a recognized TDM measure, the internalization reduction is counted towards the trip reduction goal to be achieved by the Project and the proposed TDM program described in this Plan. The mix of land uses within the Project site is a vehicle-miles traveled (VMT)

reduction strategy identified in the *Revised Proposal on Updates to the CEQA Guidelines on Evaluating Transportation Impacts in CEQA* (California Office of Planning and Research, OPR, January 2016) and *Quantifying Greenhouse Gas Mitigation Measures* (California Air Pollution Control Officers Association, CAPCOA, August 2010). This strategy is also recognized as a trip reduction measure by the City of Oakland in its adoption of VMT as the City's new traffic significance threshold for purposes of CEQA (see *Planning Commission Staff Report* – September 21, 2016). Therefore, the resulting nine percent internal trip reduction is accounted for in the Project's total trip reduction percentage associated with implementation of the TDM program.

As described in the DSEIR, the estimated trips generated by the residential and commercial components of the Project were adjusted to account for internal trips between the residential and commercial components of the Project. Internal trips are not considered as new trips on the external roadway network because they are made within the Project site. About 18 AM peak hour, 184 PM peak hour, and 1,110 daily automobile trips generated by the Project are estimated to be internal trips, which corresponds to three percent of total AM peak hour, 16 percent of total PM peak hour, and nine percent of total daily automobile trips generated by the Project.

## COMPLETE STREETS PLAN

The Oak Knoll Project would implement a Complete Streets Plan that would provide design elements that encourage and promote comfortable and safe transportation for all users. As described below, the Complete Streets Plan proposes various on-site features that encourage Project residents and visitors to walk or bike to and from commercial and recreational destinations within the site. In addition, the Complete Streets Plan proposes connections to off-site multimodal infrastructure that would allow Project residents, employees and visitors to access the site via walking, biking or transit. For example, the proposed on-site Class 1 multi-use path would connect to the planned Class 2 bicycle lanes on Mountain Boulevard and the City's bicycle network. The Complete Streets Plan would achieve a three percent mode split reduction in external vehicle trips that are among the trip reductions that would be achieved by the proposed TDM program. Furthermore, the proposed pedestrian, bicycle and transit network improvements are VMT reduction strategies identified in the *Revised Proposal on Updates to the CEQA Guidelines on Evaluating Transportation Impacts in CEQA* and *Quantifying Greenhouse Gas Mitigation Measures*. The following is a summary of the proposed complete street elements that would achieve an approximately three percent reduction in external vehicle trips.

For pedestrians, the Project proposes the following complete street elements:

- Minimum six foot sidewalks are proposed along the majority of the streets within the Project site, and only the Garden Court and Creekside Village alleyways would not provide sidewalks. Excluding the alleyways, the Project would provide a connected sidewalk network throughout the site.
- The Project would provide minimum six-foot sidewalk along the Project site frontage on Mountain Boulevard, in addition to retaining the existing sidewalks along the site frontage on Keller Avenue.
- Landscaped buffers ranging between five and six feet wide are proposed between the sidewalk and the street along all streets within the site, except alleys and courts. Landscaped buffers can improve pedestrian comfort and enhance streetscape aesthetics.
- Curb extensions (also known as bulb-outs) are proposed at intersection crossings along all streets that provide on-street parking. Curb extensions encourage lower automobile speeds and provide shorter crossing distances at pedestrian crossings.
- A 14-foot Class 1 multi-use trail is proposed between the Rifle Range Creek and the Creekside Parkway. The trail would connect Mountain Boulevard and Keller Avenue.
- In addition, off-street pedestrian paths that connect residential neighborhoods to commercial and recreational destinations within the site are also proposed. Pedestrian paths are proposed along the southern and eastern residential neighborhoods, with direct connections between the Village Commercial and Creekside Village developments. Hiking trails in the vicinity of the creek and along the northern and eastern edges of the site are also proposed. The Project would provide a pedestrian/bicycle only bridge across Rifle Range Creek, connecting the Class I multi-use trail with the proposed hiking trail along Rifle Range Creek near the Village Commercial.
- Narrow automobile travel lane widths (10-11 feet, one lane per direction), which encourage lower automobile speeds, are proposed on all streets within the Project site.

For bicyclists, the Project proposes the following complete streets elements:

- A 14-foot Class 1 multi-use trail is proposed between the Rifle Range Creek and Creekside Parkway. The Class 1 facility would connect to the planned Class 2 bicycle lanes along Mountain Boulevard.
- Class 2 bicycle lanes along the Mountain Boulevard frontage are proposed, which is consistent with the City of Oakland's plan to implement Class 2 bicycle lanes along the Mountain Boulevard corridor as part of an effort to connect it to the MacArthur Boulevard bikeway at Mills College and the Bancroft Avenue bikeway at 106<sup>th</sup> Avenue.
- Class 3 bicycle routes are proposed along Creekside Loop and Main Street. Both of these streets would provide on-street parking and one travel lane per direction with a 25 mph posted speed limit.

- A minimum of eight long-term and 43 short-term bicycle parking spaces are proposed throughout the site; a large majority of these would likely be located within the Village Commercial center; however, the specific locations of bicycle parking spaces have not yet been identified.

For transit riders, the Project proposes the following complete streets elements:

- Improve the pedestrian connections between the Project site and existing bus stops adjacent to the site on Mountain Boulevard at Creekside Parkway and on Keller Avenue at Creekside Parkway. A connected sidewalk network with minimum six foot widths is proposed throughout the site with sidewalk connections to bus stops adjacent to the site. The Project proposes to signalize the Mountain Boulevard/Creekside Parkway intersection and implement all-way-stop controls at the Keller Avenue/ Creekside Parkway intersection, which would improve pedestrian access to bus stops across Mountain Boulevard and Keller Avenue at Creekside Parkway.
- Enhance existing bus stops at the following intersections along the Project frontage:
  - Mountain Boulevard/Creekside Parkway,
  - Mountain Boulevard/Sequoyah Road, and
  - Keller Avenue/Creekside Parkway.
- Bus stop enhancements include:
  - Bus shelter and bench,
  - Wayfinding information,
  - Pedestrian scale lighting,
  - Minimum 80 foot red curb, and
  - Improved pedestrian connections between Project site and existing bus stops adjacent to the site.

## TDM PROGRAM GOALS AND STRATEGIES

### TDM PROGRAM GOALS

The SCA sets a goal for the required TDM program to reduce automobile trips by 10 percent for projects generating between 50 and 99 net new peak hour trips and by 20 percent for projects generating 100 or more net new peak hour trips. Since the proposed Project would generate over 100 AM and PM peak hour trips, the goal of this TDM program is to reduce the drive alone automobile trips by 20 percent.

Implementation of an effective TDM program can help reduce usage of the automobile as a primary mode of travel for the developments' residents, employees and visitors. In dense urban areas with high transit availability, robust TDM programs relying heavily on operational strategies have been shown to reduce automobile trips by as much as 25 percent. However, since the Project site is located in a suburban area with hilly terrain, limited transit options, and is not within walking or biking distance of major commercial or employment centers, a TDM program with only operational strategies cannot realistically achieve such reductions. Residential projects are also more difficult than institutional or commercial developments to design TDM programs for. Thus this TDM program relies on infrastructure improvements and design features, as well as operational strategies to reduce automobile trips by 20 percent, which would accomplish the following:

- Reduce external automobile trip generation by 128 AM peak hour, 230 PM peak hour, and 2,470 daily trips, which would result in the Project generating 514 AM peak hour, 919 PM peak hour, and 9,890 daily trips.

### PROPOSED TDM STRATEGIES

A combination of the commercial tenants and the proposed developments' Homeowners Association (HOA) shall implement the strategies described below. The Master Developer (Oak Knoll LLC) shall ensure that the HOA established for the Project defines these obligations as pass-along conditions of the Project. The Master Developer shall also ensure that all subsequent sales of individual development parcels acknowledge these HOA and commercial tenant obligations. **Table 1** lists these TDM strategies and summarizes their effectiveness based on research compiled in *Quantifying Greenhouse Gas Mitigation Measures* (CAPCOA, August 2010). This report is a resource for the Project Sponsor and the City of Oakland to quantify the benefit, in terms of reduced vehicle trips, of implementing various TDM strategies.

As described above, the mix of residential and commercial land uses along with the Complete Streets Plan proposed by the Project have trip reduction benefits that are also considered TDM measures.

The following operational TDM strategies are proposed for the Project<sup>1</sup>:

- **BART Shuttle** – Provide a frequent (20 – 30 minute headways), direct weekday shuttle service between the Project and the Coliseum BART station for three hours during both the peak morning and evening commute periods. This service could be operated by a private contractor or by AC Transit. Shuttles shall be fully accessible to passengers using wheelchairs and other mobility services and have the capacity to transport bicycles. In addition, provide a real-time smart-phone app that tracks real-time arrivals to make shuttle use more reliable and convenient. This Draft TDM Plan assumes operations of two shuttles (20-25 passenger capacity) with 20 – 30 minute headways during the AM and PM peak periods.
- **Car-Share Spaces** – Coordinate with car-sharing service (such as City Car Share, Zip Car, etc.) to designate at least six free on-site parking spaces for car-sharing vehicles. Monitor the usage of the carsharing spaces and adjust if necessary. Locations for on-site car-sharing parking include two spaces on the Village Commercial parking lot, one space on the Community Center parking lot, and at least three on-street spaces adjacent to areas of higher townhome density.
- **Carpool and Ride-Matching Assistance Program** – The HOA shall offer personalized ride-matching assistance to pair residents and/or employees interested in forming commute carpools. Similar to the “Casual Carpool” system used in the Bay Area, pre-determined locations around the Project site shall be identified for carpoolers to pick up passengers. Locations include Creekside Parkway near Mountain Boulevard and Keller Avenue. The curb space for carpool pick-ups shall be designated for passenger loading only during the weekday morning peak commute period. As an enhancement, the HOA shall use services such as ZimRide, TwoGo by SAP, Enterprise RideShare, or 511.org RideShare. Commercial employers shall also offer a similar personalized ride-matching assistance program.

---

<sup>1</sup> Health & Safety Code section 40717.9 prohibits local agencies from requiring an employer to implement an employee trip reduction program. The applicant has voluntarily agreed to require the employers occupying the commercial space to implement certain TDM measures in this TDM Program and will strongly encourage employers to comply with other measures.

**TABLE 1  
PROJECT AND PROPOSED TDM PROGRAM COMPONENTS THAT REDUCE VEHICLE TRIPS**

<b>Trip Reduction Strategies</b>	<b>Responsible Party</b>	<b>Implementation Timing</b>	<b>Estimated Trip Reduction<sup>1</sup></b>
<b><i>Project Design Features</i></b>			
Mixed-Used Project with Residential and Commercial Land Uses	Project Applicant	Ongoing as Project is constructed	9%
Complete Streets Plan	Project Applicant	Ongoing as Project is constructed	3%
<b><i>Operational Strategies</i></b>			
Provide BART shuttle	HOA	First phase of the Project	4%
Designate On-Site Car-Share Spaces	HOA	First phase of the Project	0.7%
Carpool and Ride-Matching Assistance	HOA and Commercial Tenants	First phase of the Project	2%
Employee Transit Fare Subsidy/Pre-Tax Commuter Benefit	Commercial Tenants	By completion of Village Center	0.3%
Bicycle Facility Monitoring	Encouraged for Commercial Tenants	First phase of the Project	NA <sup>2</sup>
Guaranteed Ride Home	HOA and Encouraged for Commercial Tenants	First phase of the Project	NA <sup>2</sup>
TDM Coordinator	HOA and Encouraged for Commercial Tenants	First phase of the Project	NA <sup>2</sup>
TDM Marketing and Education	HOA and Commercial Tenants	First phase of the Project	2%
Coordinate with AC Transit	HOA and Project Applicant	First Phase of the Project	NA <sup>3</sup>
Construction of Additional Bikeways	Project Applicant	First phase of the Project	NA <sup>4</sup>
<b>Total</b>			<b>21%</b>

Notes:

1. This analysis assumes that the automobile trip reduction would be the same as the VMT reduction. See the BAAQMD Transportation Demand Management Tool User's Guide (June 2012) for more detail.
2. The effectiveness of this strategy cannot be quantified at this time. This does not necessarily imply that the strategy is ineffective. It only demonstrates that at the time of the CAPCOA report development, existing literature did not provide a



robust methodology for calculating its effectiveness. In addition, many strategies are complementary to each other and isolating their specific effectiveness may not be feasible.

3. The effectiveness of coordinating with AC Transit cannot be quantified because it is unknown at this time if AC Transit would be willing to make route changes or provide additional service.
4. Construction of additional off-site bikeways is complementary to implementation of the Project's Complete Streets Plan, the isolated effectiveness cannot be quantified at this time.

Sources: *Quantifying Greenhouse Gas Mitigation Measures* (CAPCOA, August 2010); Fehr & Peers, 2016.

- **Employee Transit Fare Subsidy** – Commercial employers shall provide free or reduced cost transit in order to increase transit mode share. Options include:
  - Employers can offer a monthly commuter check (or alternatively Clipper Card, which is accepted by BART, AC Transit, and other major transit providers in the Bay Area) to employees to use public transit. Note that as of 2016, IRS allows up to \$255 per employee per month. This strategy allows employers to deduct monthly transit passes or other amount using pre-tax dollars. This can help to lower payroll taxes and allows employees to save on transit.
  - Employers can participate in AC Transit's EasyPass program, by which employers purchase annual bus passes for employees in bulk at a discount. The passes allow unlimited rides on all AC Transit buses for all employees. For more information, see [www.actransit.org/rider-info/easypass](http://www.actransit.org/rider-info/easypass).
- **Pre-tax Commuter Benefits** – Commercial tenants shall enroll in WageWorks or other services to help with pre-tax commuter savings. This strategy allows employees to deduct monthly transit passes or other amount using pre-tax dollars. This can help lower payroll taxes and allows employees to save on transit.
- **Bicycle Facility Monitoring** – The Project would meet the City's requirements by providing at least 43 short-term (e.g., bicycle racks) and eight long-term (e.g., bicycle lockers or bicycle garages) bicycle parking spaces for the commercial components of the Project. The commercial tenants are encouraged to monitor the usage of these facilities and provide additional bicycle parking if necessary.
- **Guaranteed Ride Home** – Encourage on-site employees and residents to register for the Guaranteed Ride Home (GRH) program. Employees and residents may be hesitant to commute by any other means, besides driving alone, since they lose the flexibility of leaving work in case of an emergency. GRH programs encourage alternative modes of transportation by offering free rides home in the case of an illness or crisis, if the employee is required to work unscheduled overtime, if a carpool or vanpool is unexpectedly unavailable, or if a bicycle problem arises. The Alameda County Transportation Commission offers a GRH service for all registered permanent employees who are employed within Alameda County, live within 100 miles of their worksite, and do not drive alone to work. The GRH program is offered at no cost to the employer, and employers are not required to register in order for their employees to enroll and use the program.

- **TDM Coordinator** – The HOA shall retain a TDM coordinator to coordinate and promote the TDM activities for the Project. Commercial Tenants are encouraged to do the same.
- **TDM Marketing and Employee/Resident Education** – On-site employers and the HOA shall provide employees, residents and visitors information about various transportation options, including information about casual carpool pick-up locations, in the Project area and the available TDM strategies. This information would also be posted at central location(s), such as the Community Center, and be provided to each commercial tenant and new residents. The information shall be regularly updated. Marketing strategies can promote transit and active transportation trips by making commuters aware of the options and incentives of using non-automobile transportation modes. Implementing commute trip reduction strategies with a complementary marketing strategy can increase the overall effectiveness of the program.
- **Coordinate with AC Transit** – The Project applicant or HOA shall coordinate with AC Transit to investigate the potential for re-routing existing AC Transit service through the Project site along Creekside Parkway between Mountain Boulevard and Keller Avenue. The Project applicant or HOA also may choose to coordinate with AC Transit to provide peak period weekday shuttle service between the Project site and the Coliseum BART station.
- **Construction of Additional Bikeways** – The Project applicant shall coordinate with City of Oakland to construct/implement bikeways that connect the Project site to the surrounding community, per the City's Bicycle Master Plan. Bikeway improvements shall include:
  - Mountain Boulevard between Golf Links Road and the Westbound I-580 On-Ramp/ Maynard Avenue
  - Golf Links Road/98<sup>th</sup> Avenue between Mountain Boulevard and Stanley Avenue
  - Edwards Avenue between Mountain Boulevard and the Eastbound I-580 Off-Ramp
  - Kuhnle Avenue/Seminary Avenue between Mountain Boulevard and Overdale Avenue

As shown in **Table 1**, proposed TDM strategies are estimated to achieve a combined 21 percent total trip reduction, which exceeds the 20 percent goal established for the Project. Overall, this TDM Program is estimated to reduce external automobile trip generation by 135 AM peak hour, 241 PM peak hour, and 2,590 daily trips, which would result in the Project generating 507 AM peak hour, 908 PM peak hour, and 9,770 daily trips.

## ADDITIONAL TDM STRATEGIES

If the TDM program does not meet the 20 percent trip-reduction goal, the implementation of additional measures will be considered for inclusion in the ongoing TDM efforts, such as, but not limited to, the following:

- **Expanded Shuttle Service** – Increase the frequency of the BART shuttle and/or expand the service area to include other destinations, such as Downtown Oakland or other employment or commercial areas. The effectiveness of the shuttle service would depend on the destinations served and the frequency of the service.
- **Resident Transit Fare Subsidy** – Similar to the employee transit fare subsidy, the Project applicant or HOA shall provide free or discounted transit fares for residents (such as commuter check, Clipper Card, pre-paid high-value BART tickets, AC Transit EasyPass, etc). The effectiveness of the transit fare subsidy would depend on the amount of subsidy provided.

## MONITORING, EVALUATION AND ENFORCEMENT

Consistent with the requirements of the City's Standard Conditions of Approval, this TDM program requires regular periodic evaluation of the program to determine if the program goals in reducing automobile trips are satisfied and to assess the effectiveness of the various strategies implemented. Beginning the first year after complete development and occupancy of the first phase of the Project, the Project sponsor<sup>2</sup> shall prepare an annual TDM monitoring report consisting of the following:

- On-site employee and resident transportation survey to monitor the number of driving trips to and from the site.
- Summary of TDM measures implemented by on-site employers and HOA and their effectiveness (e.g., bicycle parking occupancy, number of transit passes issued, etc.).
- Weekday AM and PM peak period and daily traffic volume counts at the site access points along Mountain Boulevard and Keller Avenue to verify peak hour trip generation for the site.

The monitoring report shall describe the TDM programs and services that are currently offered to employees/residents and summarize the findings of the vehicle counts and mode share surveys, noting if they comply with the established vehicle trip reduction goals. The first monitoring report shall be prepared six months after full occupancy of the first phase of the Project. Subsequent monitoring reports shall be prepared annually.

If in two successive years the Project's TDM goals are not satisfied, the HOA shall prepare and submit for City approval a Corrective Action Plan. The Corrective Action Plan shall detail additional TDM measures to be implemented on-site and their expected automobile trip reductions.

If, one year after the Corrective Action Plan is implemented, the required automobile mode trip reduction target is still not being achieved, or if the HOA fails to submit a report as described above, or if the reports do not meet City requirements outlined above, the City may, in addition to its other remedies, (a) assess the HOA a financial penalty based on the observed reduction in the automobile trips compared to the target; or (b) refer the matter to the City Planning Commission for scheduling of a compliance hearing to determine whether additional corrective measures and/or penalties shall be imposed on the HOA.

In determining whether a financial penalty or other remedy is appropriate, the City shall not impose a penalty if the Project has made a good faith effort to comply with the TDM program. The City would only have the ability to impose a monetary penalty after a reasonable cure period and in accordance with the

---

<sup>2</sup> The Project sponsor may designate the HOA and/or commercial tenants to prepare the annual trip monitoring report.

enforcement process outlined in Planning Code Chapter 17.152. If a financial penalty is imposed, such penalty sums shall be used by the City solely toward the implementation of the TDM Plan.

If in five successive years (including at least one year reflecting complete development/occupancy of the entire Project), the Project is found to meet the stated TDM goal, additional surveys and monitoring shall not be required.

**APPENDIX A:  
CITY OF OAKLAND STANDARD CONDITION OF APPROVAL FOR TDM**



## CITY OF OAKLAND TDM PLAN REQUIREMENTS

Preparation of a TDM plan is a requirement of the City of Oakland's Standard Conditions of Approval (Department of Planning and Building, Bureau of Planning, Revised July 22, 2015). The Standard Conditions of Approval (SCA) states the following:

### **Transportation and Parking Demand Management**

#### **a. Transportation and Parking Demand Management (TDM) Plan Required**

Requirement: The project applicant shall submit a Transportation and Parking Demand Management (TDM) Plan for review and approval by the City.

- i. The goals of the TDM Plan shall be the following:
  - Reduce vehicle traffic and parking demand generated by the project to the maximum extent practicable, consistent with the potential traffic and parking impacts of the project.
  - Achieve the following project vehicle trip reductions (VTR):
    - Projects generating 50-99 net new AM or PM peak hour vehicle trips: 10 percent VTR
    - Projects generating 100 or more net new AM or PM peak hour vehicle trips: 20 percent VTR
  - Increase pedestrian, bicycle, transit, and carpool/vanpool modes of travel. All four modes of travel shall be considered, as appropriate.
  - Enhance the City's transportation system, consistent with City policies and programs.
- ii. TDM strategies to consider include, but are not limited to, the following:
  - Inclusion of additional long-term and short-term bicycle parking that meets the design standards set forth in chapter five of the Bicycle Master Plan and the Bicycle Parking Ordinance (chapter 17.117 of the Oakland Planning Code), and shower and locker facilities in commercial developments that exceed the requirement.
  - Construction of and/or access to bikeways per the Bicycle Master Plan; construction of priority bikeways, on-site signage and bike lane striping.
  - Installation of safety elements per the Pedestrian Master Plan (such as crosswalk striping, curb ramps, count down signals, bulb outs, etc.) to encourage convenient and safe crossing at arterials, in addition to safety elements required to address safety impacts of the project.
  - Installation of amenities such as lighting, street trees, and trash receptacles per the Pedestrian Master Plan and any applicable streetscape plan.
  - Construction and development of transit stops/shelters, pedestrian access, way finding signage, and lighting around transit stops per transit agency plans or negotiated improvements.
  - Direct on-site sales of transit passes purchased and sold at a bulk group rate (through programs such as AC Transit Easy Pass or a similar program through another transit agency).

- *Provision of a transit subsidy to employees or residents, determined by the project applicant and subject to review by the City, if employees or residents use transit or commute by other alternative modes.*
- *Provision of an ongoing contribution to transit service to the area between the project and nearest mass transit station prioritized as follows: 1) Contribution to AC Transit bus service; 2) Contribution to an existing area shuttle service; and 3) Establishment of new shuttle service. The amount of contribution (for any of the above scenarios) would be based upon the cost of establishing new shuttle service (Scenario 3).*
- *Guaranteed ride home program for employees, either through 511.org or through separate program.*
- *Pre-tax commuter benefits (commuter checks) for employees.*
- *Free designated parking spaces for on-site car-sharing program (such as City Car Share, Zip Car, etc.) and/or car-share membership for employees or tenants.*
- *On-site carpooling and/or vanpool program that includes preferential (discounted or free) parking for carpools and vanpools.*
- *Distribution of information concerning alternative transportation options.*
- *Parking spaces sold/leased separately for residential units. Charge employees for parking, or provide a cash incentive or transit pass alternative to a free parking space in commercial properties.*
- *Parking management strategies including attendant/valet parking and shared parking spaces.*
- *Requiring tenants to provide opportunities and the ability to work off-site.*
- *Allow employees or residents to adjust their work schedule in order to complete the basic work requirement of five eight-hour workdays by adjusting their schedule to reduce vehicle trips to the worksite (e.g., working four, ten-hour days; allowing employees to work from home two days per week).*
- *Provide or require tenants to provide employees with staggered work hours involving a shift in the set work hours of all employees at the workplace or flexible work hours involving individually determined work hours.*

*The TDM Plan shall indicate the estimated VTR for each strategy, based on published research or guidelines where feasible. For TDM Plans containing ongoing operational VTR strategies, the Plan shall include an ongoing monitoring and enforcement program to ensure the Plan is implemented on an ongoing basis during project operation. If an annual compliance report is required, as explained below, the TDM Plan shall also specify the topics to be addressed in the annual report.*

*When Required:* *Prior to approval of construction-related permit*

*Initial Approval:* *Bureau of Planning*

*Monitoring/Inspection:* *N/A*

**b. TDM Implementation – Physical Improvements**

*Requirement:* *For VTR strategies involving physical improvements, the project applicant shall obtain the necessary permits/approvals from the City and install the improvements prior to the completion of the project.*



When Required: Prior to building permit final

Initial Approval: Bureau of Building

Monitoring/Inspection: Bureau of Building

**c. TDM Implementation – Operational Strategies**

Requirement: For projects that generate 100 or more net new AM or PM peak hour vehicle trips and contain ongoing operational VTR strategies, the project applicant shall submit an annual compliance report for the first five years following completion of the project (or completion of each phase for phased projects) for review and approval by the City. The annual report shall document the status and effectiveness of the TDM program, including the actual VTR achieved by the project during operation. If deemed necessary, the City may elect to have a peer review consultant, paid for by the project applicant, review the annual report. If timely reports are not submitted and/or the annual reports indicate that the project applicant has failed to implement the TDM Plan, the project will be considered in violation of the Conditions of Approval and the City may initiate enforcement action as provided for in these Conditions of Approval. The project shall not be considered in violation of this Condition if the TDM Plan is implemented but the VTR goal is not achieved.

When Required: Ongoing

Initial Approval: Bureau of Planning

Monitoring/Inspection: Bureau of Planning

**Appendix H**  
Club Knoll Final Development  
Plan (FDP)

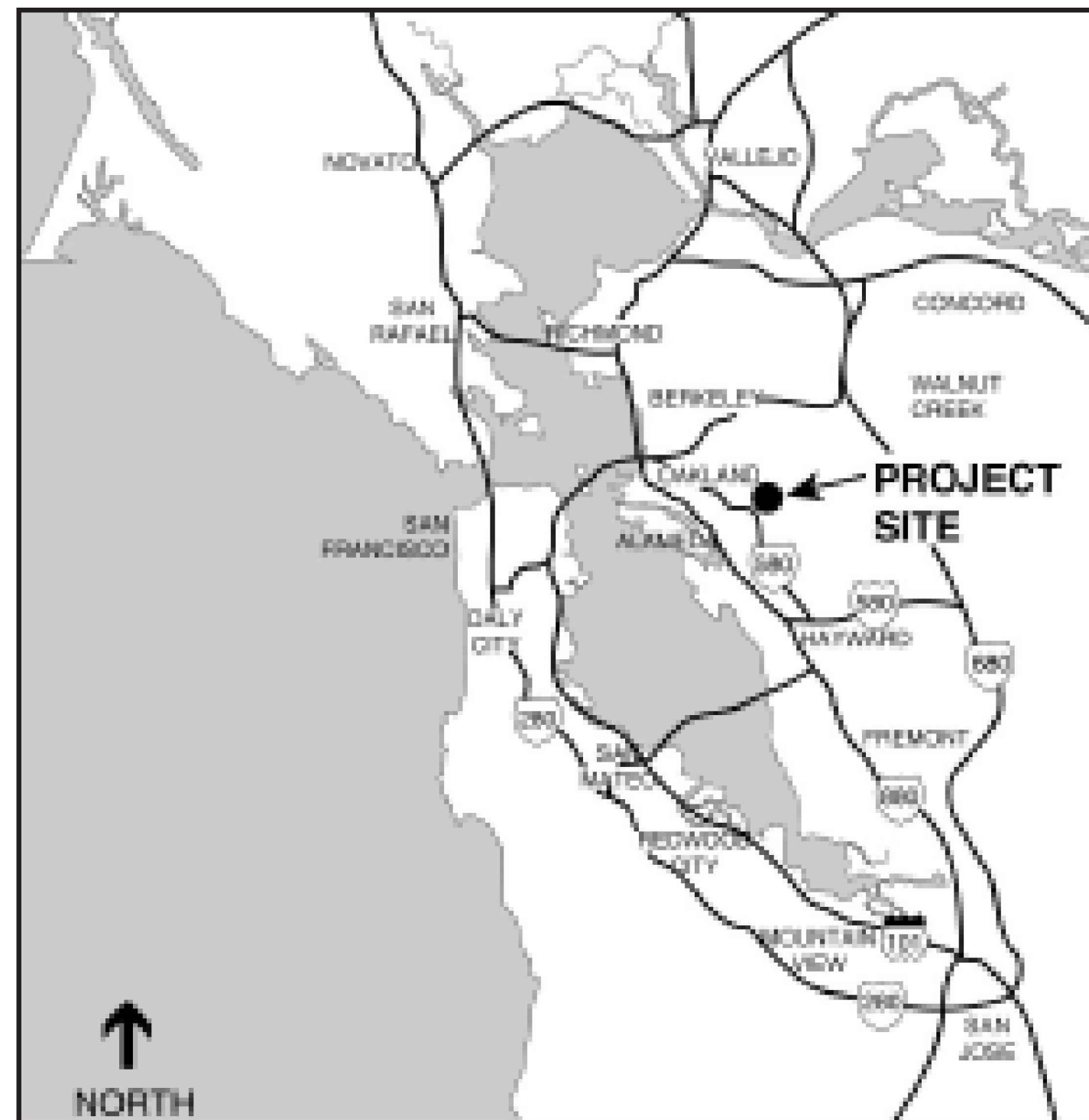
# FINAL DEVELOPMENT PLAN: CLUB KNOLL RELOCATION AND REHABILITATION

April 03, 2017

## DRAWING INDEX

DR-1	TITLE SHEET
DR-2.1	PROJECT NARRATIVE
DR- 2.2	PROJECT NARRATIVE
DR-3	PHOTOGRAPHS
DR-4	EXISTING BUILDING SITE
DR-5.1	EXISTING CONDITIONS AT NEW SITE
DR-5.2	MASTER GRADING PLAN AT NEW SITE
DR-6	PROPOSED SITE PLAN
DR-7	FLOOR PLANS
DR-8.1	BUILDING SECTIONS
DR-8.2	BUILDING SECTIONS
DR-9.1	EXTERIOR ELEVATIONS
DR-9.2	EXTERIOR ELEVATIONS
DR-10	MATERIALS BOARD
DR-11.1	LANDSCAPE PLAN
DR-11.2	PLANTING MATERIALS
DR-12.1	METHODOLOGY OF RELOCATION
DR-12.2	METHODOLOGY OF RELOCATION
DR-12.3	METHODOLOGY OF RELOCATION
DR-12.4	METHODOLOGY OF RELOCATION
DR-12.5	METHODOLOGY OF RELOCATION
DR-12.6	PROPOSED TRAVEL ROUTE
DR-12.7	RELOCATION AND REPLACEMENT MATRIX BY PART/ COMPONENT
DR-12.8	RELOCATION AND REPLACEMENT MATRIX BY PART/ COMPONENT
DR-13.1	EXTERIOR MODEL ON NEW SITE
DR-13.2	VIEW STUDIES
DR-14	COMPLETED INTERIORS
APPENDIX A- RELOCATION SEQUENCE	

### LOCATION MAP N.T.S.



### PROJECT INFORMATION

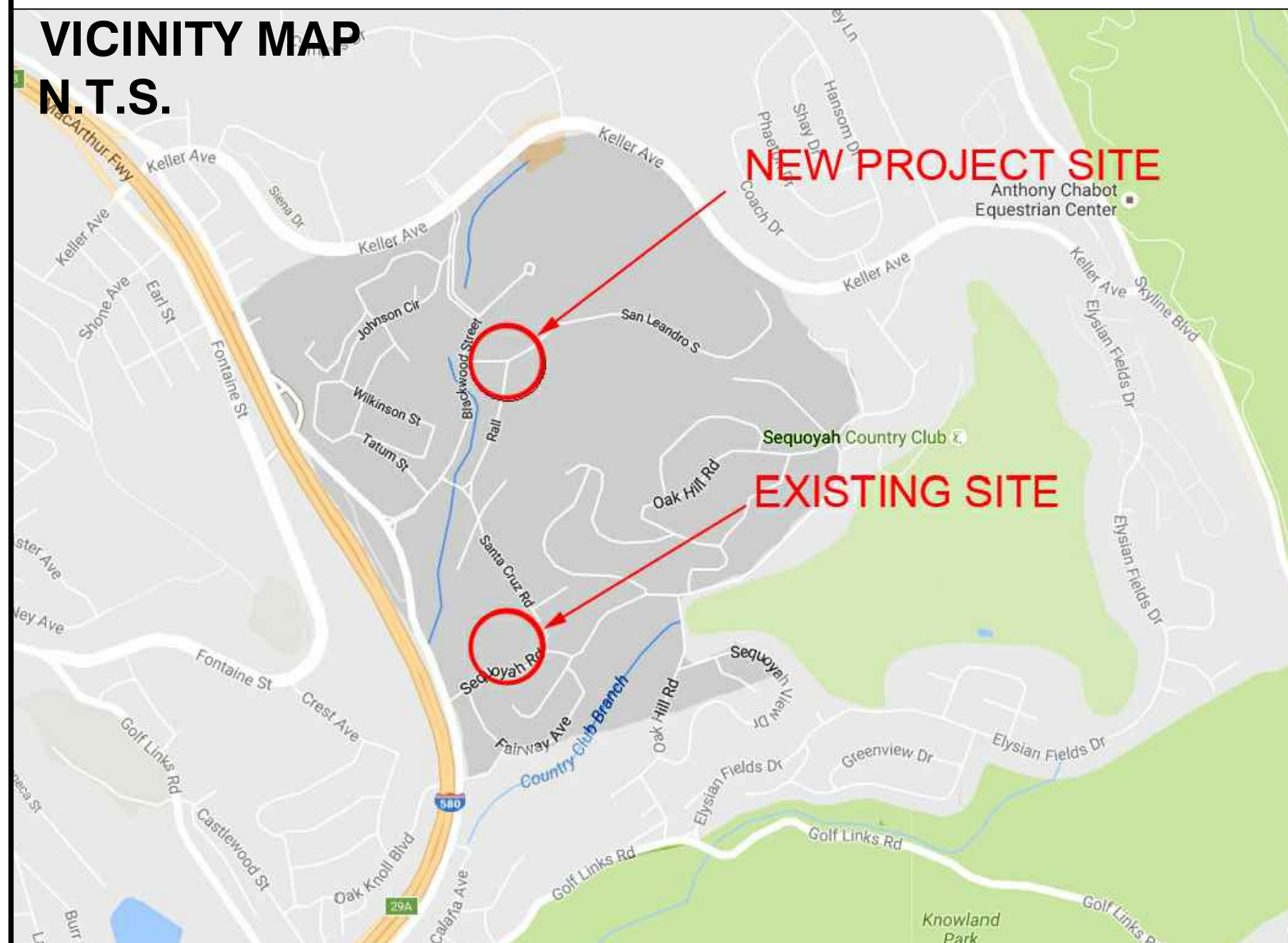
This Final Development Plan (FDP) for Club Knoll is the second FDP submitted for the Oak Knoll Master Planned Development and is referred to in this document as the "Club Knoll FDP" or "FDP #2." The applicant has also prepared FDP #1, which seeks planning-level approval of final schematic plans for the master developer-installed improvements for the project as a whole, including development of the pad location for the relocated Clubhouse, site-wide grading and retaining walls, design of streets, parks, street furniture, utilities, monumentation and restoration of Rifle Range Creek.

Specific sheets from FDP#1 are referenced herein and incorporated by reference where they depict streets, sidewalks, utilities, and signage in the immediate vicinity of the new location for Club Knoll.

PROJECT LOT SIZE : 120,580 S.F.

ZONING : D-OK Sub-Zone

### VICINITY MAP N.T.S.



### PROJECT DIRECTORY

**DEVELOPER:**  
OAK KNOLL VENTURE ACQUISITIONS, LLC  
2392 MORSE AVENUE  
IRVINE, CA 92614  
949.777.4000

**ARCHITECT:**  
ARCHITECTURAL DIMENSIONS  
300 FRANK H. OGAWA PLAZA,  
SUITE 375 OAKLAND, CA 94612  
510.463.8300, FAX: 510.463.8395

**LANDSCAPE ARCHITECT:**  
GOLDEN ASSOCIATES  
300 FRANK H. OGAWA PLAZA,  
SUITE 308 OAKLAND, CA 94612  
510.465.4030

**MASTER PLANNER AND ARCHITECT:**  
HART HOWERTON  
ONE UNION ST. 3RD FLOOR  
SAN FRANCISCO, CA 94111  
415.439.2200

**LAND USE COUNSEL:**  
COX, CASTLE AND NICHOLSON  
50 CALIFORNIA STREET, SUITE 3200  
SAN FRANCISCO, CA 94111  
415.262.5107

**CIVIL ENGINEER:**  
BKF ENGINEERS  
300 FRANK H. OGAWA PLAZA,  
OAKLAND, CA 94612  
650.482.6300

### CLUB KNOLL, PRIOR TO 1996 CLOSURE



ARCHITECTURAL  
DIMENSIONS

300 Frank H. Ogawa Plaza, Suite 375  
Oakland, CA 94612  
TEL. 510.463.8300 • FAX. 510.463.8395

PROJECT INFO.

CLUB KNOLL  
MOUNTAIN BLVD. & SEQUOYAH RD  
OAKLAND, CA. 94605

TITLE SHEET

JOB NO.  
SC002  
DATE.  
04.03.2017

DRAWING NO.  
DR-1

# PROJECT NARRATIVE

## A. GENERAL EXPLANATION

This Final Development Plan (FDP #2) for the relocation and rehabilitation of Club Knoll is prepared in accordance with Oakland Municipal Code section 17.140.040. The intent of this FDP is to demonstrate “the ultimate appearance and operation” of the relocated, rehabilitated building at its new site. This FDP seeks planning-level approval for the restored Clubhouse and includes a description of the relocation and rehabilitation process. Construction-level plans including more detailed plans and studies required as mitigation measures (as discussed further below) will be submitted prior to issuance of demolition and building permits. The work to relocate and rehabilitate the building will be in accordance with the Secretary of the Interior Standards for Rehabilitation and recommendations of the Carey & Co. Relocation Evaluation Report dated March 10, 2016.

This FDP #2 has been prepared to be consistent with the Preliminary Development Plan for the Oak Knoll Master Planned Community, which addresses the project as a whole. To the extent relevant to the Club Knoll relocation site, this FDP #2 also incorporates by reference the Final Development Plan for the Master Developer Improvements (FDP #1), in particular sheets L-005 and L-008.

## B. EXISTING STRUCTURE

Club Knoll, a former golf clubhouse and then officer's club when the site was under Navy ownership, is located in the southwestern part of the Project site near Sequoyah Road (the site's southern boundary) and is currently in disrepair, having been vacant since the Navy vacated the site approximately twenty years ago. The existing building is a wood-framed structure sitting on a concrete foundation part of which retains the adjoining hillside around the lower basement level on three sides of the building.

The current condition of the building is fair to poor. However, with careful dismantling, relocation and repair/relocation of building components, it is feasible to relocate the main portions of the building. *Significant interior work will be required to bring the building up to code, which work would also be required to safely rehabilitate the building if left in place.*

Prior to commencing work on the building, the project sponsor will adhere to all required pre-construction mitigation measures including **Mitigation Measure CUL-1** (HABS Documentation). Specifically, the project sponsor shall document the existing building according to Historic American Building Standards (HABS) standards, which requires:

- (a) a full set of measured drawings depicting the building; (b) photographs with large format negatives of exterior and interior views of the existing building; (c) identification of how the receiving site will be prepared to receive the new building, including grading and construction of the foundation. (For the full text of each mitigation measure, see the Draft SEIR and the Mitigation Monitoring and Reporting Program.)

Further, prior to approval of construction-related permits, the project sponsor shall prepare a Building Features Inventory and a complete set of

schematic floor and roof plans of existing and proposed building conditions in accordance with **Mitigation Measure CUL 1.2** (*Baseline Building Conditions Study*). As part of this building inventory, building components will be identified as catalogued in accordance with **Mitigation Measure CUL1.5(d)** (*Specific Relocation/Rehabilitation Measures*)

Additional requirements concerning the Building Features Inventory are found in **Mitigation Measure CUL-1.4**. (*Building Features Inventory and Plan*).

In this inventory, the features, components and parts to be relocated will be specifically identified. Features that are deteriorated or damaged beyond repair will be replaced. Specific vendors and subcontractors to carry out the restoration and relocation work will be identified. A complete set of schematic floor and roof plans and elevations will also be provided showing existing conditions, elements to be demolished and schematic plans for the building in its restored and relocated condition.

## C. THE NEW SITE

This FDP #2 describes and depicts the relocation of the building to a central portion of the site and reuse of the major components of the building as a community center for the Home Owner Association (HOA) and other commercial accessory uses. (The HOA portions of the building will be available for rent by the general public, subject to availability and the discretion of the HOA Board of Directors.)

The new site will preserve the openness around the building in a setting comparable to the existing one where the front of the building faced a large landscaped area (former golf course) and the rear faced a parking lot. While the historic golf course was eliminated years ago and is not being replicated, the orientation of the building on the new site puts the front of the building facing an existing, large landscaped and restored creek area that is lower in grade than the building, much like the existing setting.

The lower grade at the front of the new building is comparable to the existing setting, thereby enabling the lower portion of the façade (referred to as the basement) to remain and to ensure that the character and proportions of the front of the building are retained. A large staircase will extend from the low grade up to the main level as is the case with the existing building. As such, the building design is in conformance with **Mitigation Measures CUL 1.5(j)**, which requires that the foundation is “constructed such that the building, at the exterior stair location on the west elevation, is raised above to the surrounding finished grade.”

The new site will have a large, uninterrupted expanse that allows viewing of the building from all sides, a betterment over the existing site. Access to the front of the building will be pedestrian-oriented, where visitors will traverse along a path then up a staircase to the main entry, similar to the existing condition. See Drawings at DR-9.1 and DR-13.1. The landscape surrounds will provide trees and plants consistent with the heritage of the region, unlike the existing site that contains non-native species.

The rear of the building will give access to the Courtyard and utility areas by vehicle, as it does today. The rear of the building, with lower architectural elements, will not block views of the building from the adjoining roads.

The relocation site will be prepared to receive the building by grading a pad and constructing a new foundation as depicted in DR 6-2 and 6-3. Staging and storage areas will also be created to receive the building components. The route to transport the building components from the existing site to the new site will be along the existing road that runs roughly in a north/south direction and is used to access Club Knoll in its existing location. A temporary road extension will be built to connect this existing road to the new Creekside Loop Road, which can be used to access the receiving site. See Proposed Travel Route at DR- 12.6. The exact location of the travel route will be identified prior to approval of construction-level permits in accordance with **Mitigation Measure CUL-1.3**. (*Relocation Travel Route*)

## D. RELOCATION OF THE STRUCTURE

The portions of the building to be relocated include the main hall, dining hall, lobby/mezzanine areas, building wings, courtyard and tower. The components of the building proposed for demolition include the basement and the additional third wing used for administrative/office purposes. Demolition of the basement is proposed because it is not practical to excavate and relocate a structure that is predominantly built into the hillside and which is exposed only on one side. The office wing is not proposed for relocation because it is not a significant contributor to the historic significance of the building and relocation of the building without this component will not cause a substantial adverse impact to the building as a historic resource.

It is intended that the largest components of building possible will be moved intact to avoid full dismantlement of the building and a substantial adverse change. Moving components of the building requires taking the building apart in a manner that allows saving the components for lifting and transportation to the new site. There are physical constraints to maximizing the size of components to enable movement of the components to the new site and reassembly. Until the dismantlement process begins, it is not possible to precisely define the size and configuration of the intact components. As noted above, in accordance with **Mitigation CUL-1-4** (*Building Features Inventory and Plan*), a plan will be prepared showing the exact components proposed for demolition as well as the location of where the building will be dismantled into moveable components. In accordance with **Mitigation Measure CUL 1-5**, a preservation architect and a structural engineer will be on site to monitor the dismantling of the building.

In accordance with **Mitigation Measure CUL 1.5(a)**, the existing building will be braced and shored to ensure structural stability of the building during dismantlement that will weaken the building as components are cut away for relocation. The bracing will be reversible, additive, and shall not destroy any salvageable historic parts of the buildings. Similarly, the new building will require a new steel frame as a skeleton to receive the existing components.

## PROJECT NARRATIVE CONT.

This approach takes the burden of the existing building components being structural sound internally (i.e. no shear capacity within the existing walls) or having capacity to work together to withstand current environmental forces. A new steel frame will be the code compliant structure on to which the existing components can be assembled thus taking off the burden of making the existing components structurally sound as a building unit. In accordance with **Mitigation Measure CUL 1.5(e)**, the new steel frame and new interior systems will not be visible in the relocated building except as necessary for life safety or in newly installed kitchen, bathrooms, elevators or other systems. A new skeleton will avoid the need for the old building components to be upgraded to sustain current code forces--- a process that would be more impactful than moving the components. The structural frame will be designed to fit within the existing components as much as practical.

### E. SALVAGED PARTS (Exterior and Interior)

There are many parts of the building that will be salvaged, restored and reassembled in the building. Parts are elements of the building that can be removed, resorted and reinserted into the reassembled building in their original locations. The list of Parts includes the following:

- Roof Tiles
- Roof Trusses
- Doors
- Windows
- Columns
- Corbels
- Emblems
- Wood Trim (interior and exterior)
- Wood Flooring
- Truss Base Moldings
- Railings
- Hardware

As these parts are salvaged, they will be cataloged, protected and stored in a dry, secure area in compliance with **Mitigation Measure CUL-1.5(d)**. In accordance with **Mitigation Measure CUL 1-4**, salvaged parts will be restored or, if missing or so deteriorated or damaged that repair is not feasible, replaced. Replaced elements will be marked with a date stamp in an inconspicuous location to ensure that they are not confused with original elements. Cleaning, painting or staining of such parts may be necessary to remove graffiti, mold, rust or water stains. Care shall be taken to match any new materials with the original materials. Restoration will be performed off-site by qualified vendors and contractors.

### F. EXISTING INTERIOR SYSTEMS

Existing systems are defined as mechanical, electrical, plumbing and fire protection equipment, piping, ducts, conduits, wire, etc. In the current

building, these existing systems are either missing due to vandalism or are defunct due to age. There are no systems in the building that are viable for reuse; therefore, new interior systems will be required.

### G. NEW INTERIOR SYSTEMS

New mechanical, electrical, plumbing and fire protection systems will be designed to integrate into the historic fabric of the relocated building. The building did have and will have adequate spaces and cavities to allow inclusion of new systems without detriment to the interior design features of the building. Where feasible, new systems will be current code compliant and not affect the physical characteristics of the historic resource. The California State Historical Building Code will be invoked where necessary to retain historic character.

### H. EXISTING and NEW INTERIOR FINISHES

Most of the existing interior finishes have been compromised beyond restoration. Finishes are defined as surface materials on substrates, such as paint, wall coverings, some wood paneling, some wood flooring, etc. Existing finishes have been damaged due to vandalism and exposure to natural elements. Reassembly of the building will include application of new finishes to match the original as best can be determined from research about the building and examination of existing finishes.

### I. EXISTING and NEW SUBSTRATES

Substrates are defined as underlying materials to finishes that structurally support finishes such as plaster, wood sheathing, wood framing, etc. As with existing finishes, there is a lot of damaged substrate particularly due to water infiltration. Substrates before modern drywall and plywood included plaster and wood framing that has been negatively affected and cannot be reused or restored as such materials have lost their structural integrity, particularly the plaster that is laden with hazardous asbestos.

New substrates will include wood framing, plywood, plaster, and drywall to support the new finishes. Interior substrates while critical to holding the interior finishes are not visible or part of the historic fabric inside the building.

### J. EXISTING and NEW EXTERIOR SUBSTRATE

Windows, doors, windows and roof aside, the exterior of the building is plaster. The existing plaster is sound in most areas that will be retained with components of the building that will be moved. Cutting the building to create components, to be moved, will require cutting through the plaster that will be repaired after reassembly of the building. Damaged or deteriorated plaster will be replaced. Care will be taken to match materials in accordance with **Mitigation Measure CUL-1.4(f)**.

### K. EXISTING and NEW EXTERIOR FINISHES

The primary exterior finish is paint. After reassembly, the entire building will be repainted with colors to match the original color scheme. Salvaged exterior parts such as windows, doors and roof tiles will be reinstated after assemblage of the components. Construction consistent with building standards of the 1920's, does not provide structural resistance to environmental loads dictated by the current building code. While the building's future tenancy might be the same type as prior occupancies, it is likely that rehabilitation, where the building sits today, would require structural upgrades to a newer standard (than 1926), thus requiring some severe infiltration into the building's structure to improve its capacity. In other words, restoration of the building in place would require temporary impact to facilitate infusion of new structural improvements. This effort is comparable to the impact from the relocation effort being proposed.

### L. STANDARDS

The dismantlement, reassembly and rehabilitation of the building will be executed in accordance with the Secretary of the Interior's Standards for the Treatment of Historic Properties. In accordance with **Mitigation Measure CUL 1.5**, a preservation architect and a structural engineer will be on site to monitor the reassembly of the building. There will be minimal changes to the defining characteristics of the building and its site and environment. The historic character of the building shall be retained and preserved. Construction will not destroy historic materials that characterize the building and any new work shall vary but be compatible with the massing, size, scale and architectural features to protect the historic integrity of the building and its environment. Care will be taken to reassemble the building in a manner that minimizes cracking as the building settles and different materials respond to environmental conditions.

### M. SEQUENCE OF WORK

The dismantlement of the existing building and reassembly process will occur concurrently. While the building is being dismantled, and its parts salvaged, the new building site would be prepared to allow immediate transport and reassembly of components with minimal storage thereof. To the extent feasible, it is important that existing components be moved and reassembled in one effort.

Dismantlement and immediate reassembly requires preparation of the new site to complete foundation and structural skeleton before components are moved. Completion of the new foundation requires grading, installation of new underground utilities. Receipt of components requires completion of the structural steel frame to allow connection of the components to the frame.

Dismantlement and reassembly will take approximately 6 months to where the building is completely relocated. This will be followed by installation of systems, salvaged parts and finishes taking about another 6 months.

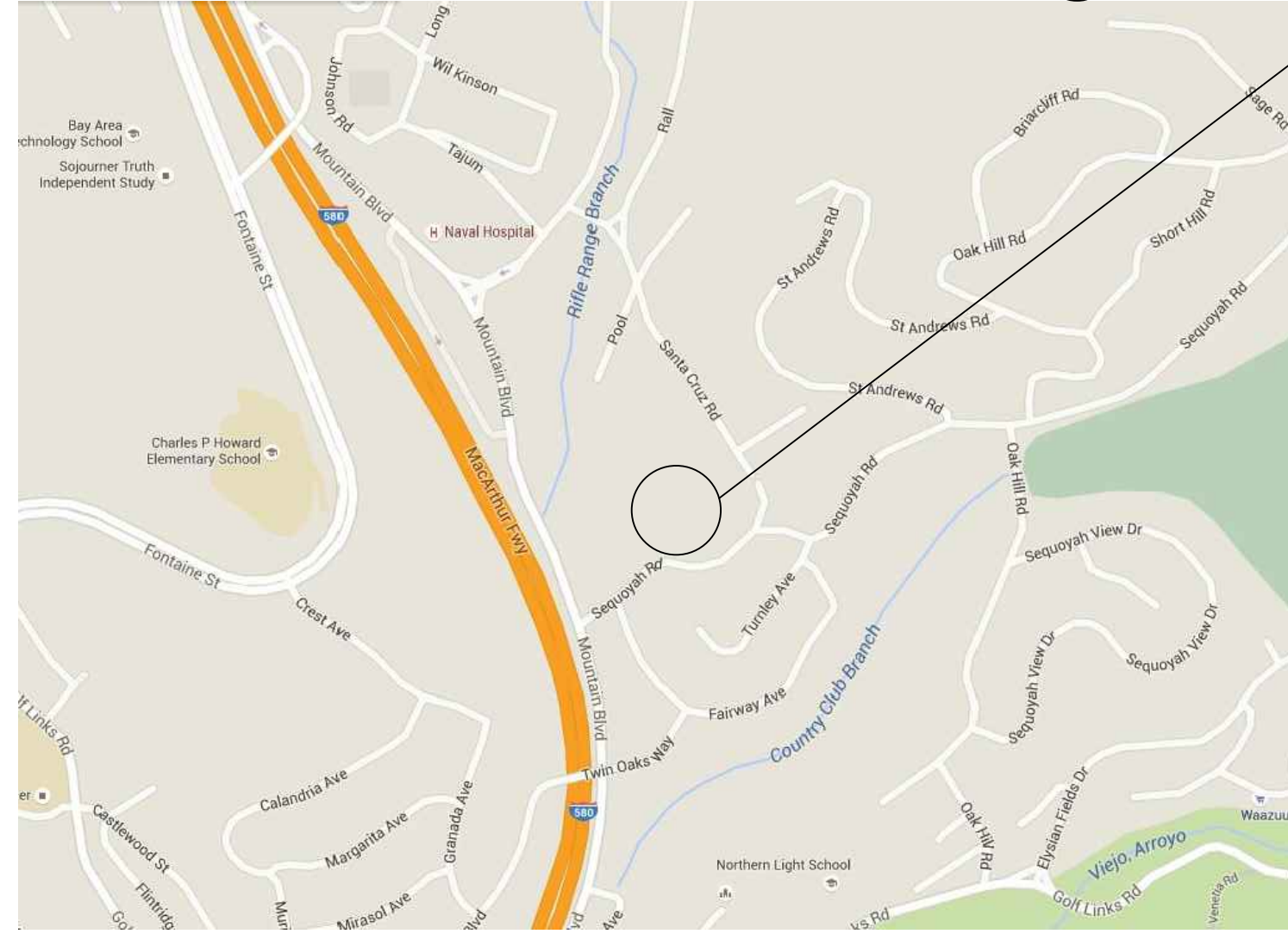
# EXTERIOR



# INTERIOR



Existing Site



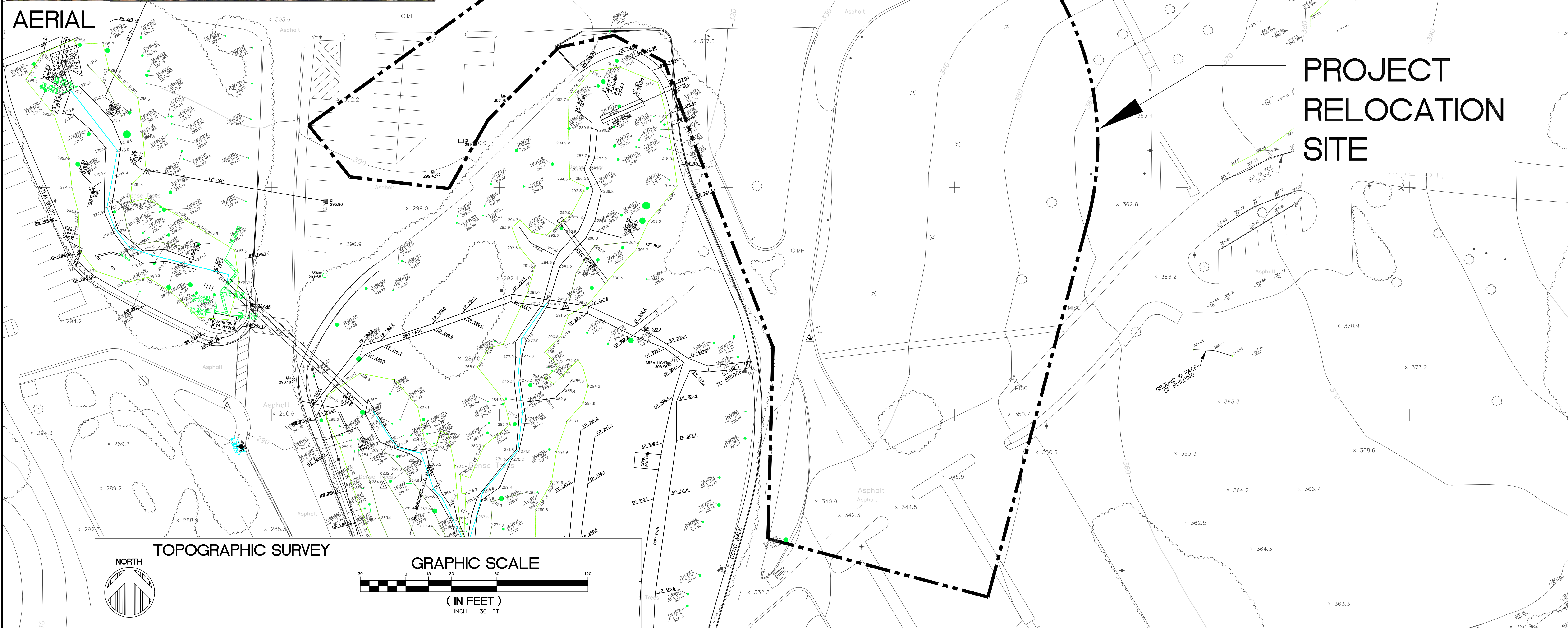
VICINITY MAP  
N.T.S.



EXISTING SITE



**AERIAL**



**PROJECT  
RELOCATION  
SITE**

**TOPOGRAPHIC SURVEY**

**NORTH**

**GRAPHIC SCALE**

**( IN FEET )**  
1 INCH = 30 FT.

**ARCHITECTURAL  
DIMENSIONS**

300 Frank H. Ogawa Plaza, Suite 375  
Oakland, CA 94612  
TEL. 510.463.8300 • FAX. 510.463.8395

PROJECT INFO.

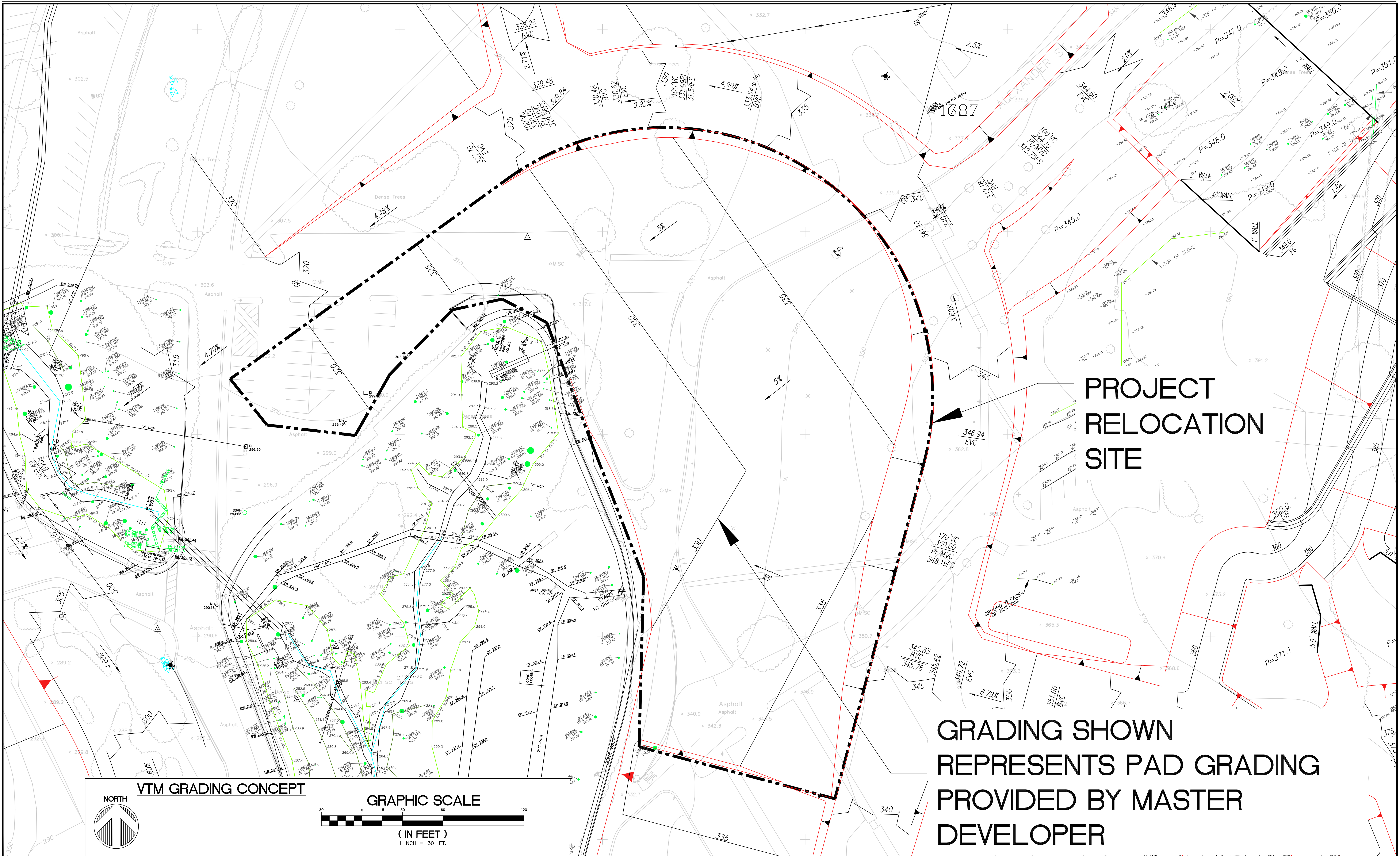
**CLUB KNOLL**  
MOUNTAIN BLVD. & SEQUOYAH RD  
OAKLAND, CA. 94605

**EXISTING  
CONDITIONS  
AT NEW SITE**

JOB NO.  
**SC002**  
DATE.  
01.27.2017

DRAWING NO.  
**DR-5.1**





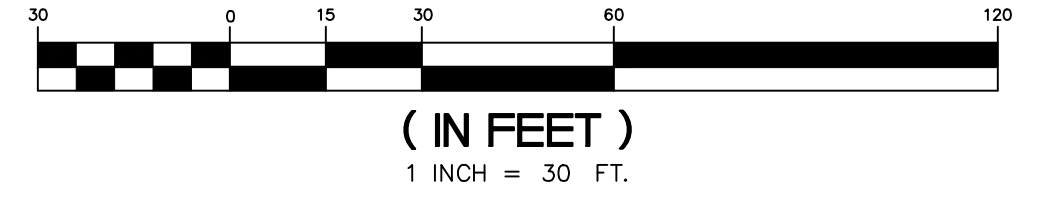
**PROJECT  
RELOCATION  
SITE**

**GRADING SHOWN  
REPRESENTS PAD GRADING  
PROVIDED BY MASTER  
DEVELOPER**

**VTM GRADING CONCEPT**



**GRAPHIC SCALE**



**ARCHITECTURAL  
DIMENSIONS**

300 Frank H. Ogawa Plaza, Suite 375  
Oakland, CA 94612  
TEL. 510.463.8300 • FAX. 510.463.8395

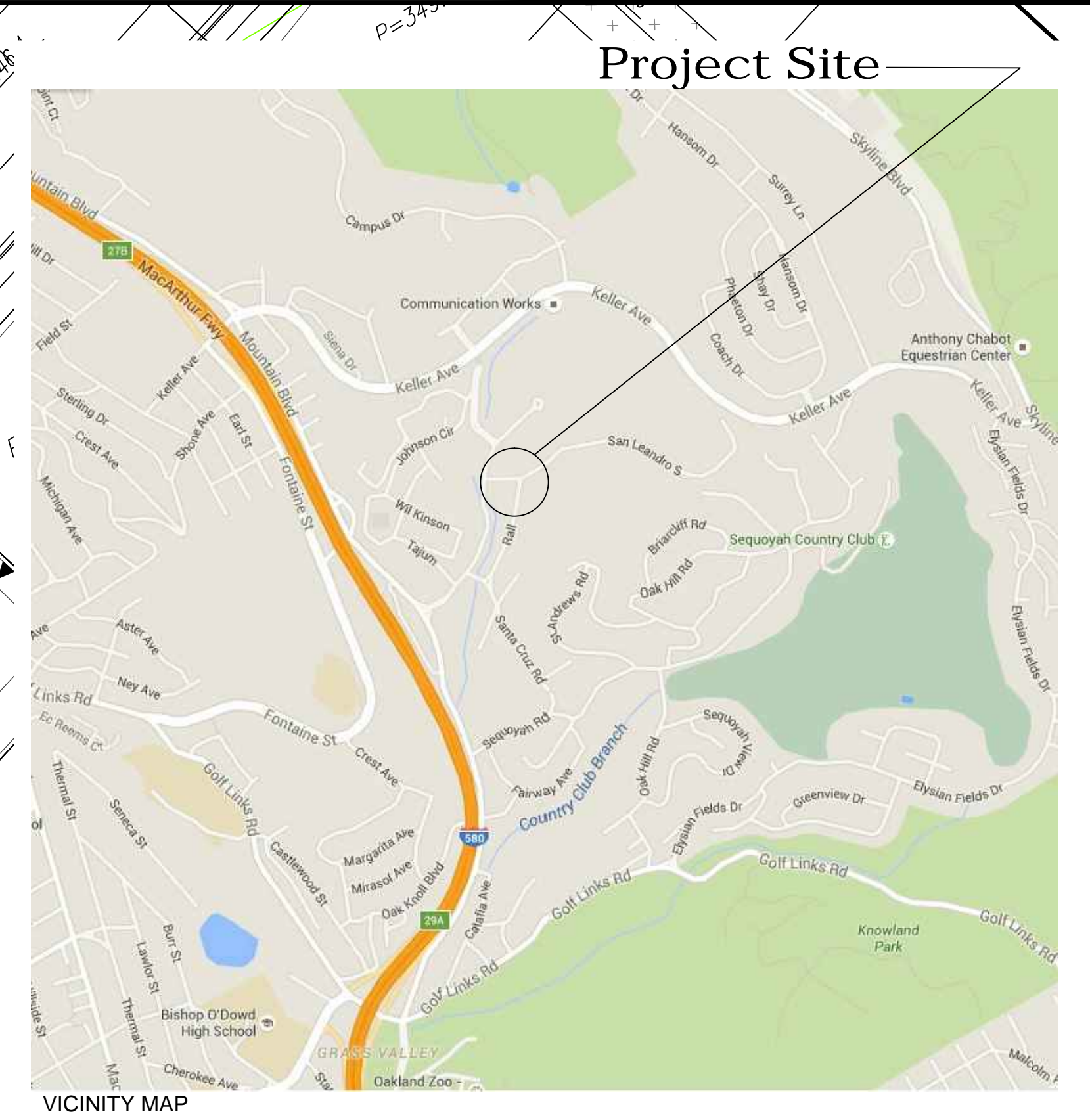
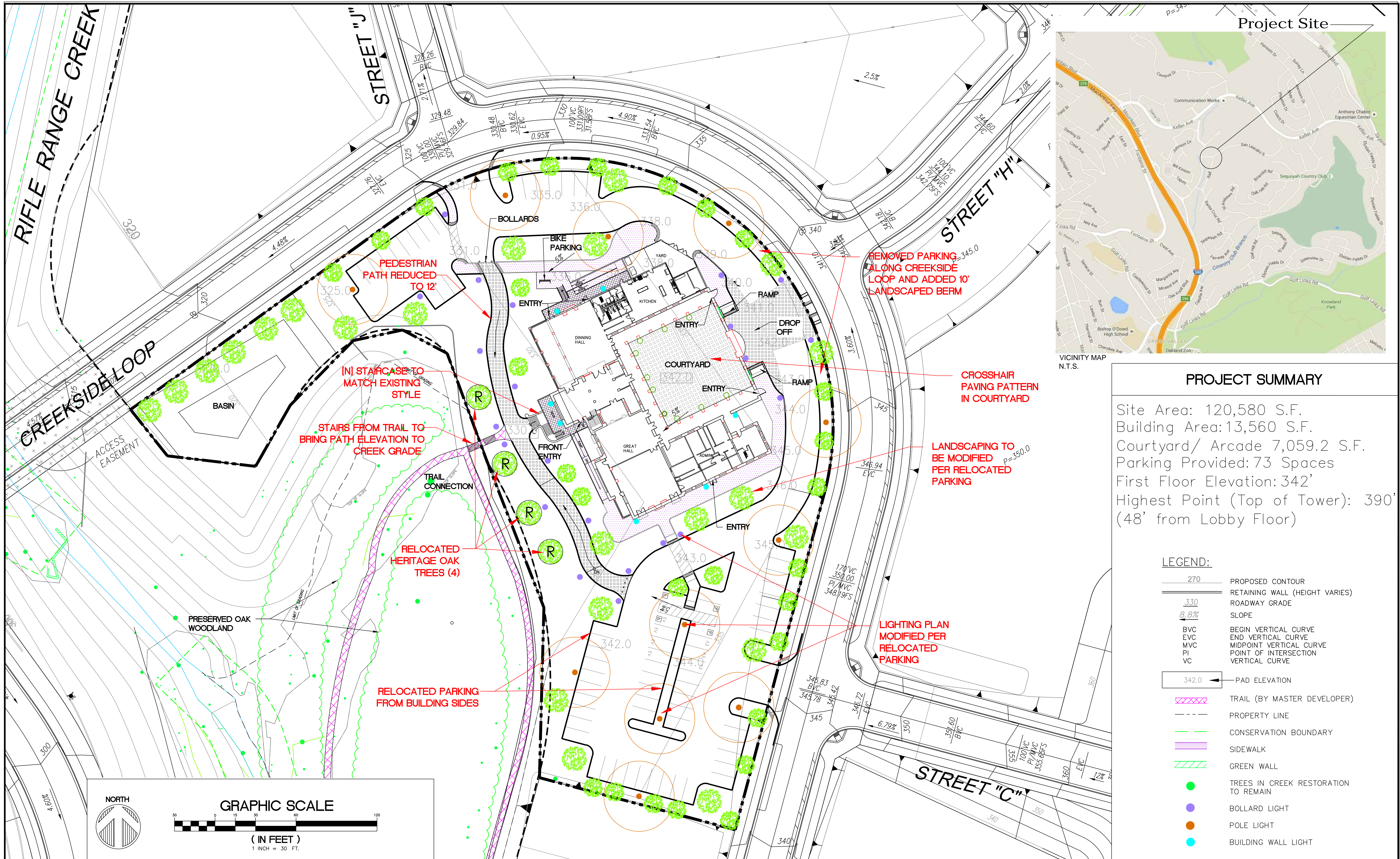
PROJECT INFO.

**CLUB KNOLL**  
MOUNTAIN BLVD. & SEQUOYAH RD  
OAKLAND, CA. 94605

**MASTER GRADING  
PLAN AT NEW SITE**

JOB NO.  
**SC002**  
DATE.  
01.27.2016

DRAWING NO.  
**DR-5.2**



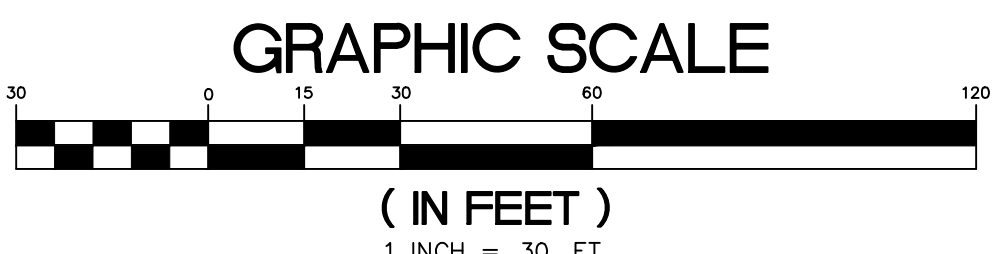
VICINITY MAP N.T.S.

**PROJECT SUMMARY**

Site Area: 120,580 S.F.  
 Building Area: 13,560 S.F.  
 Courtyard/ Arcade 7,059.2 S.F.  
 Parking Provided: 73 Spaces  
 First Floor Elevation: 342'  
 Highest Point (Top of Tower): 390'  
 (48' from Lobby Floor)

**LEGEND:**

- 270 PROPOSED CONTOUR
- RETAINING WALL (HEIGHT VARIES)
- ROADWAY GRADE
- 8.8% SLOPE
- BVC BEGIN VERTICAL CURVE
- EVC END VERTICAL CURVE
- MVC MIDPOINT VERTICAL CURVE
- PI POINT OF INTERSECTION
- VC VERTICAL CURVE
- 342.0 PAD ELEVATION
- TRAIL (BY MASTER DEVELOPER)
- PROPERTY LINE
- CONSERVATION BOUNDARY
- SIDEWALK
- GREEN WALL
- TREES IN CREEK RESTORATION TO REMAIN
- BOLLARD LIGHT
- POLE LIGHT
- BUILDING WALL LIGHT



**ARCHITECTURAL DIMENSIONS**

300 Frank H. Ogawa Plaza, Suite 375  
 Oakland, CA 94612  
 TEL. 510.463.8300 • FAX. 510.463.8395

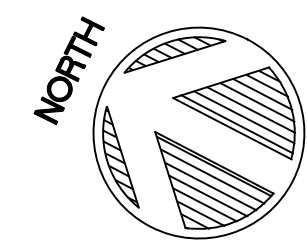
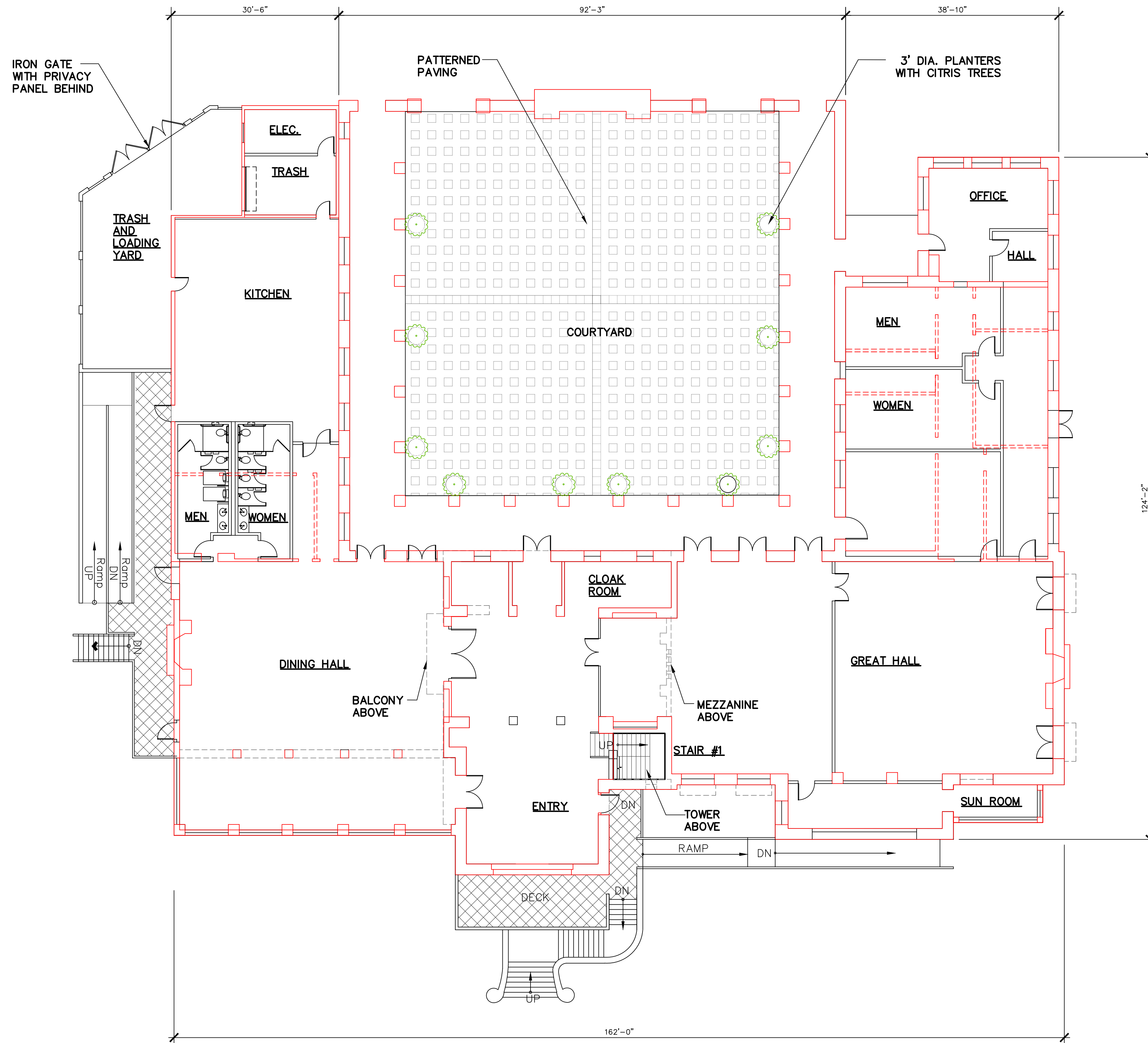
PROJECT INFO.

**CLUB KNOLL**  
 MOUNTAIN BLVD. & SEQUOYAH RD  
 OAKLAND, CA. 94605

**PROPOSED SITE PLAN**

JOB NO. **SC002**  
 DATE. **01.27.2017**

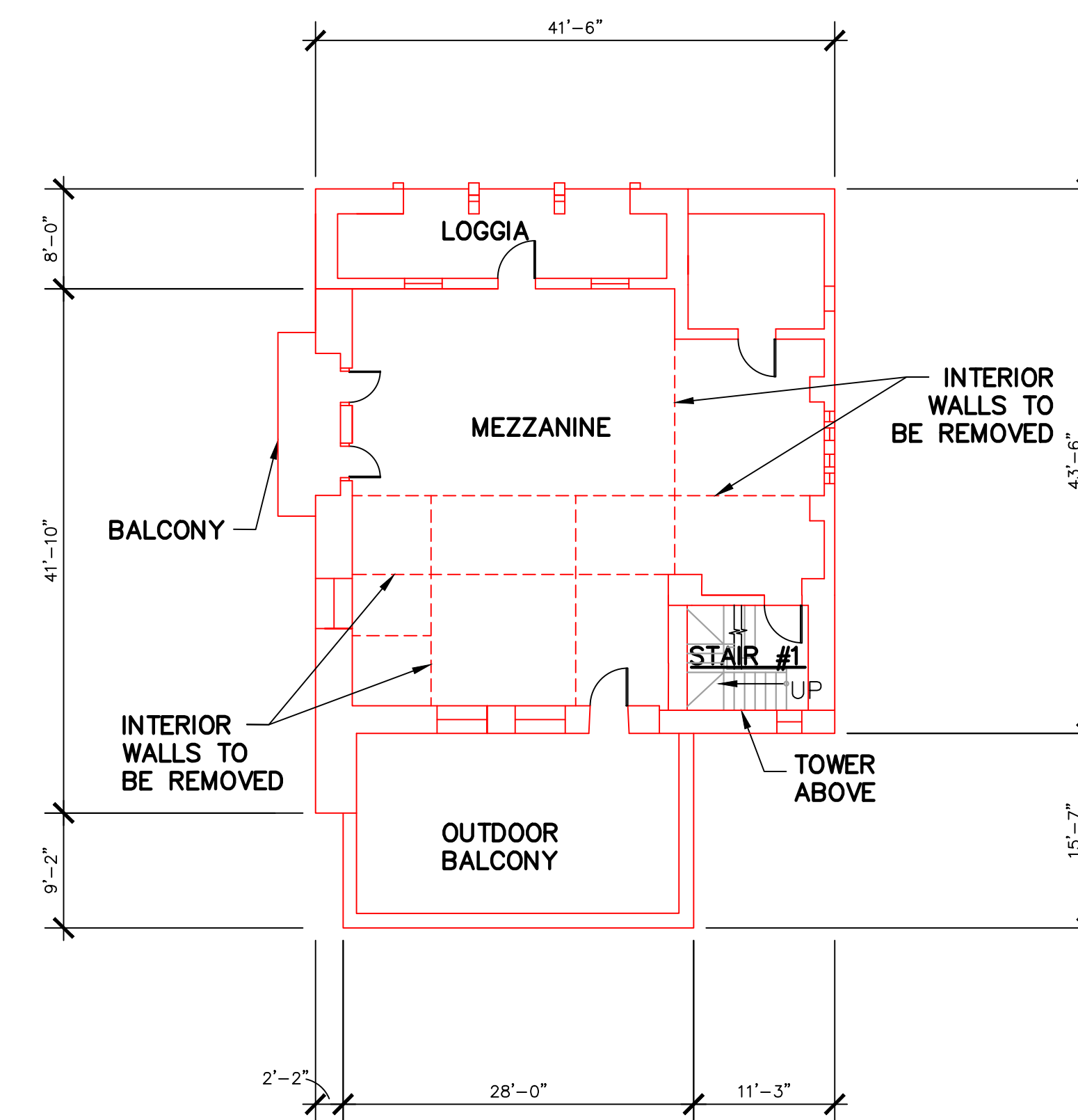
DRAWING NO. **DR-6**



**FLOOR PLAN- GROUND LEVEL**

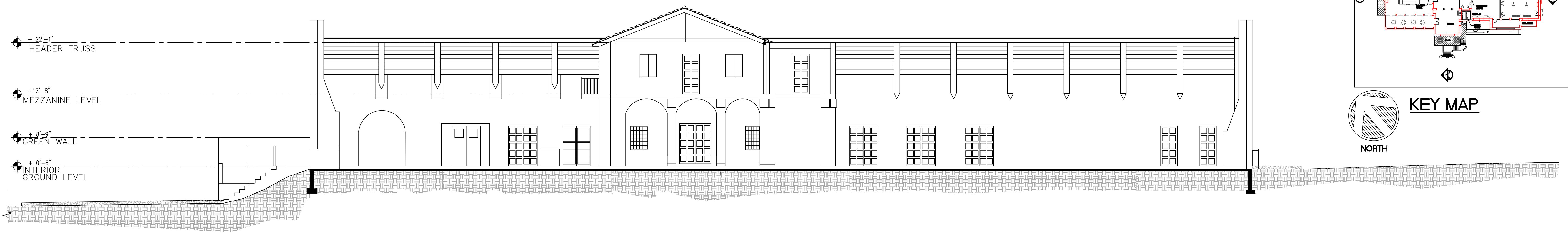
3/64" = 1'-0"

- ### NOTES
1. EXISTING WALLS IN RED  
(----- TO BE REMOVED)
  2. NEW POSSIBLE WORK IN BLACK FOR FUTURE TENANTS UNKNOWN

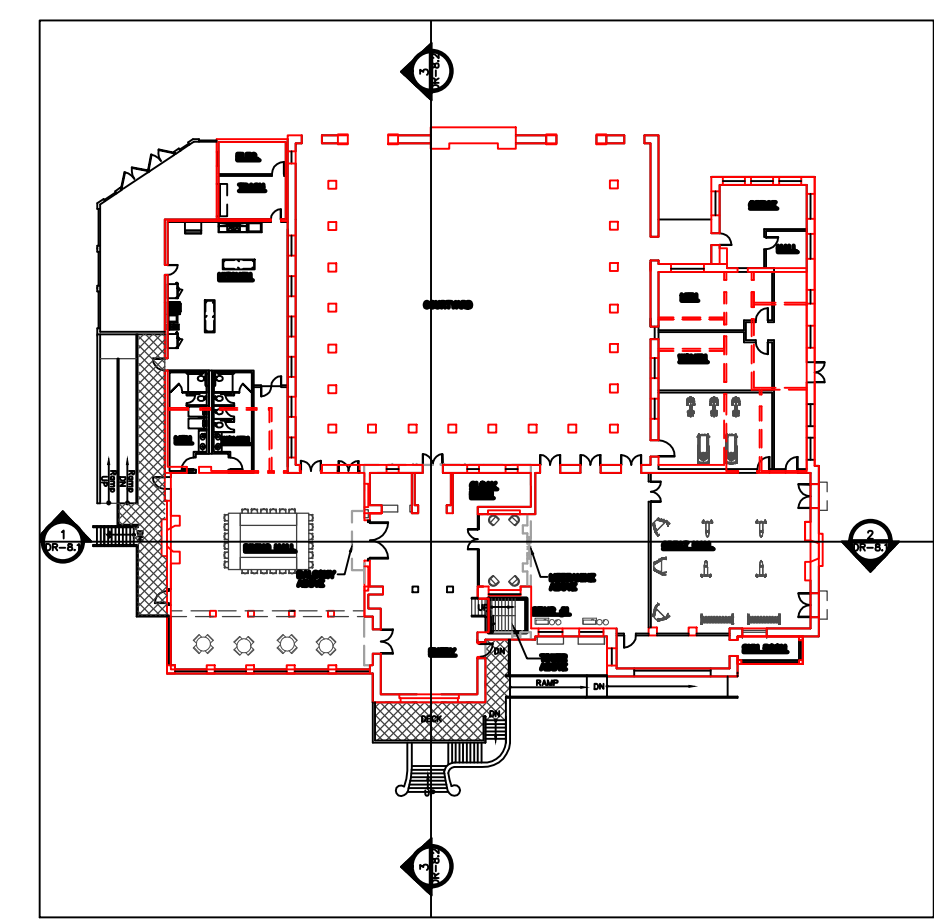


**FLOOR PLAN- MEZZANINE LEVEL**

3/64" = 1'-0"

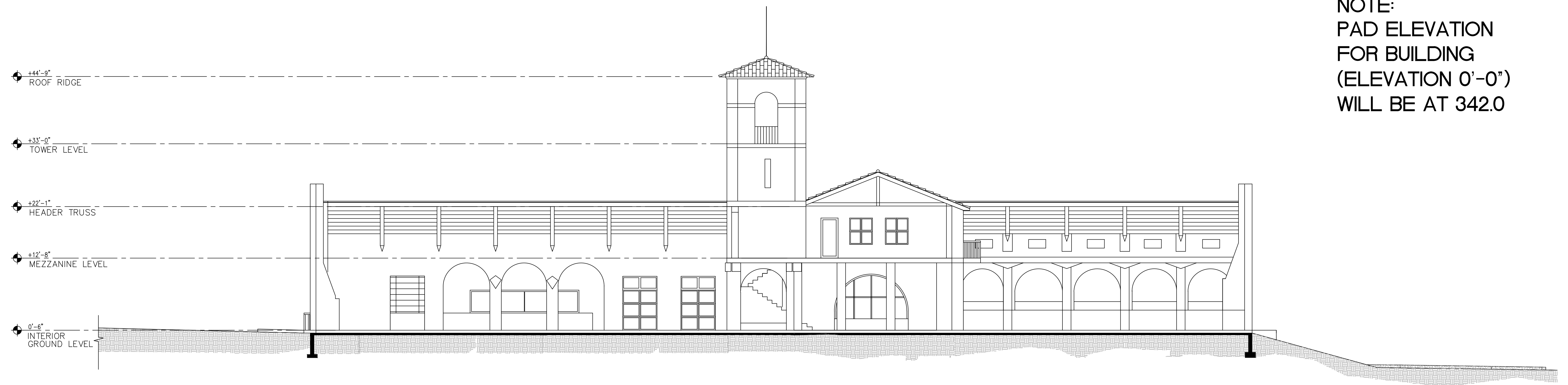


**1 NORTH SECTION**  
SCALE: 1/8" = 1'-0"

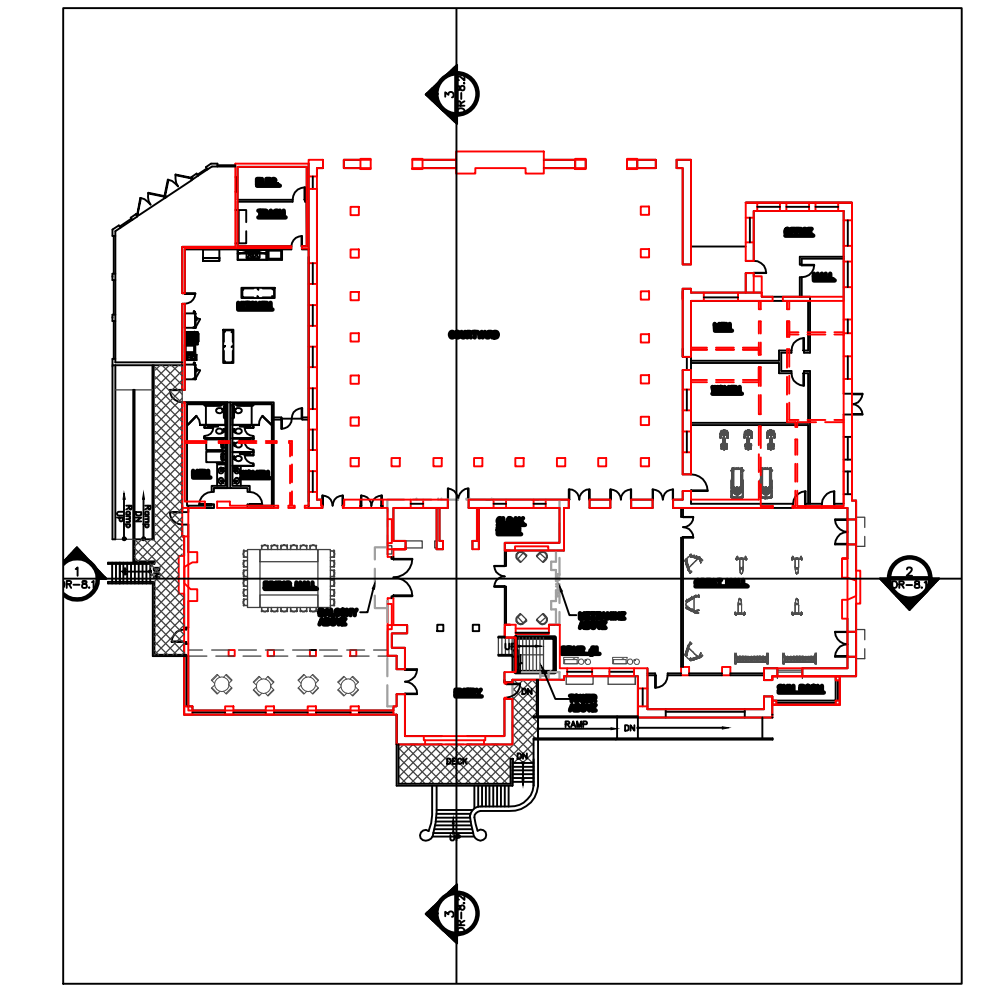


**KEY MAP**  
NORTH

**NOTE:**  
PAD ELEVATION  
FOR BUILDING  
(ELEVATION 0'-0")  
WILL BE AT 342.0



**2 SOUTH SECTION**  
SCALE: 1/8" = 1'-0"



**KEY MAP**  
NORTH

**NOTE:**  
PAD ELEVATION  
FOR BUILDING  
(ELEVATION 0'-0")  
WILL BE AT 342.0



**3 WEST SECTION**  
SCALE: 1/8" = 1'-0"



**North Elevation**

Scale: 1/8" = 1'-0"



**West (Front) Elevation**

Scale: 1/8" = 1'-0"

**General Exterior Elevation Notes**

1. Colors indicated on this drawing are approximate and will vary depending on printer/monitor display source. Refer to Colors and Materials Boards for true representation of all proposed finishes.
2. All landscaping indicated on this drawing is diagrammatic and intended only to convey a sense of general landscaped areas. Refer to actual Landscape Plan for all proposed landscaping.

**Material/Finish Legend**

Refer to Colors and Materials Boards for true representation of all proposed finishes.

- STC-1** Painted Smooth Stucco
- CT-1** Clay Tile
- GLZ-1** Glazing
- PW-1** Painted Wood

**Keynotes**

Note: Not all keynotes listed apply to this particular sheet.

- 1** (N) Front Staircase and Accessible Ramp
- 2** Restored Windows
- 3** (N) Lighting Fixtures
- 4** Commemorative Plaque
- 5** Restored Doors
- 6** Restored Metal Corbels
- 7** Restored Juliet Balcony
- 8** Restored Wooden Details
- 9** Restored Metal Handrails

+48'-0" T.O. TOWER

+32'-4" TOWER LEVEL

+8'-4" MEZZANINE LEVEL

+0'-0" GROUND FLOOR

+48'-0" T.O. TOWER

+32'-4" TOWER LEVEL

+8'-4" MEZZANINE LEVEL

+0'-0" GROUND FLOOR

-12'-0" BOTTOM OF STAIRS

**General Exterior Elevation Notes**

- Colors indicated on this drawing are approximate and will vary depending on printer/monitor display source. Refer to Colors and Materials Boards for true representation of all proposed finishes.
- All landscaping indicated on this drawing is diagrammatic and intended only to convey a sense of general landscaped areas. Refer to actual Landscape Plan for all proposed landscaping.

**Material/Finish Legend**

Refer to Colors and Materials Boards for true representation of all proposed finishes.

- STC-1** Painted Smooth Stucco
- CT-1** Clay Tile
- GLZ-1** Glazing
- PW-1** Painted Wood

**Keynotes**

Note: Not all keynotes listed apply to this particular sheet.

- 1** (N) Front Staircase and Accessible Ramp
- 2** Restored Windows
- 3** (N) Lighting Fixtures
- 4** Commemorative Plaque
- 5** Restored Doors
- 6** Restored Metal Corbels
- 7** Restored Juliet Balcony
- 8** Restored Wooden Details
- 9** Restored Metal Handrails



**South Elevation**  
Scale: 1/8" = 1'-0"



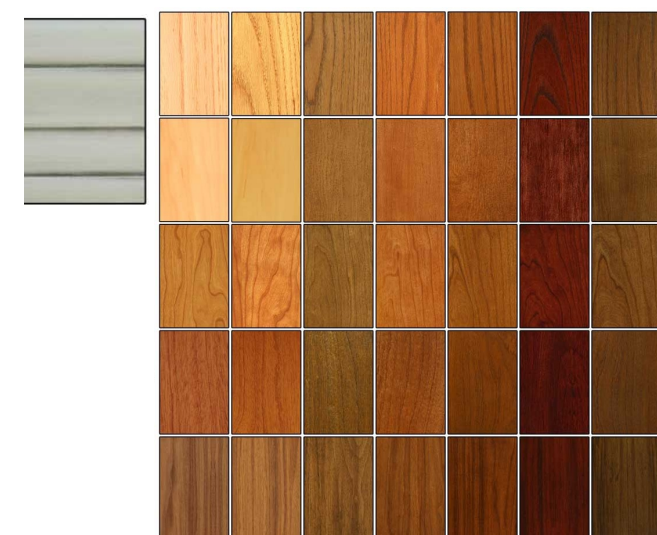
**East (Rear) Elevation**  
Scale: 1/8" = 1'-0"



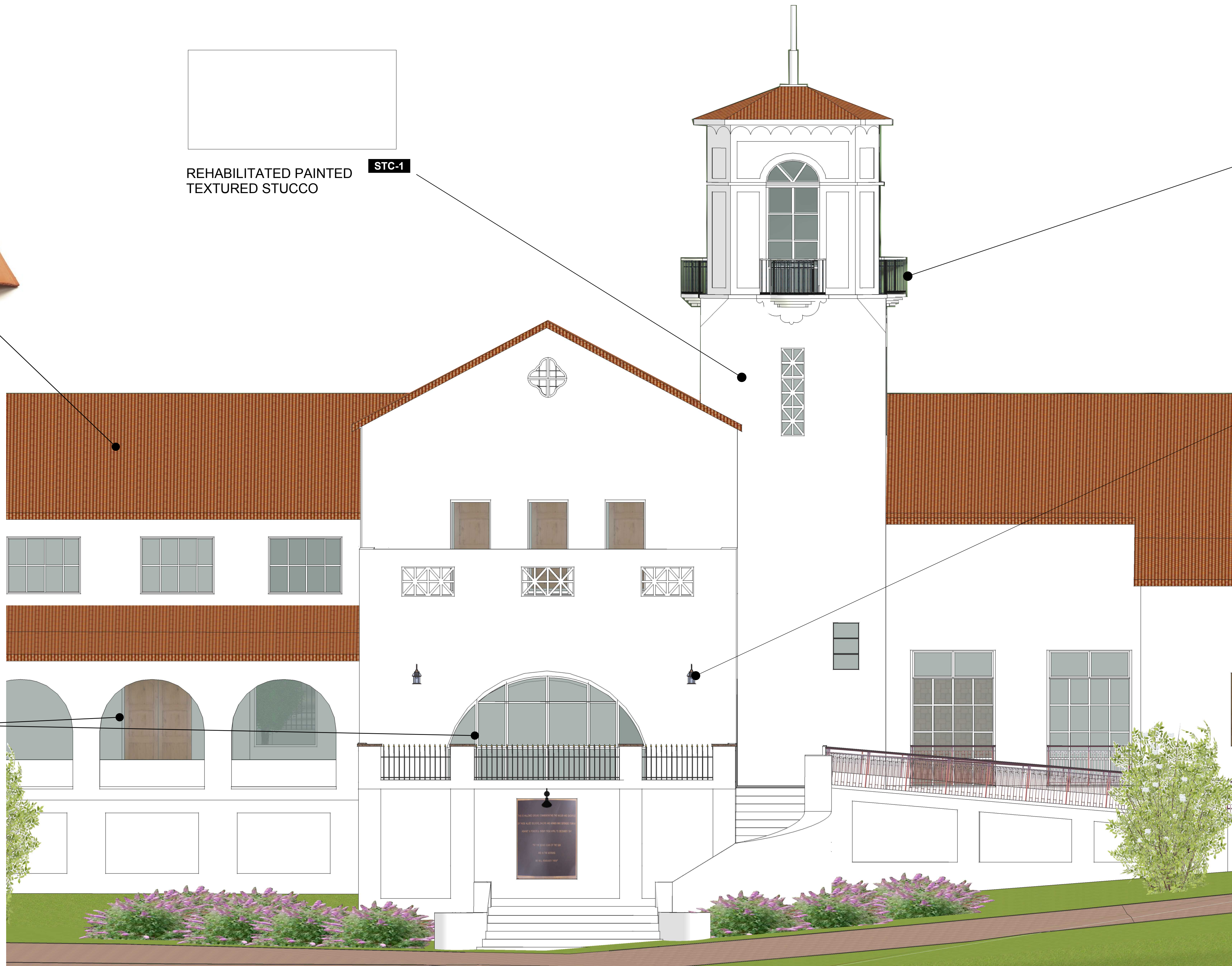
**CT-1**  
RECLAIMED AND RESTORED  
CLAY TILES



**STC-1**  
REHABILITATED PAINTED  
TEXTURED STUCCO



**PW-1**  
RESTORED WOOD TO  
MATCH EXISTING  
WINDOW AND DOOR  
FRAMES



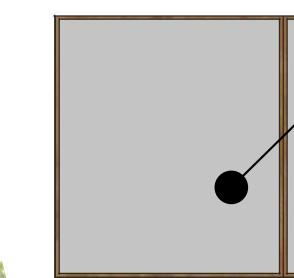
**MTL-1**  
RESTORED METAL RAILINGS



**LT-1**  
EXTERIOR LIGHT FIXTURE



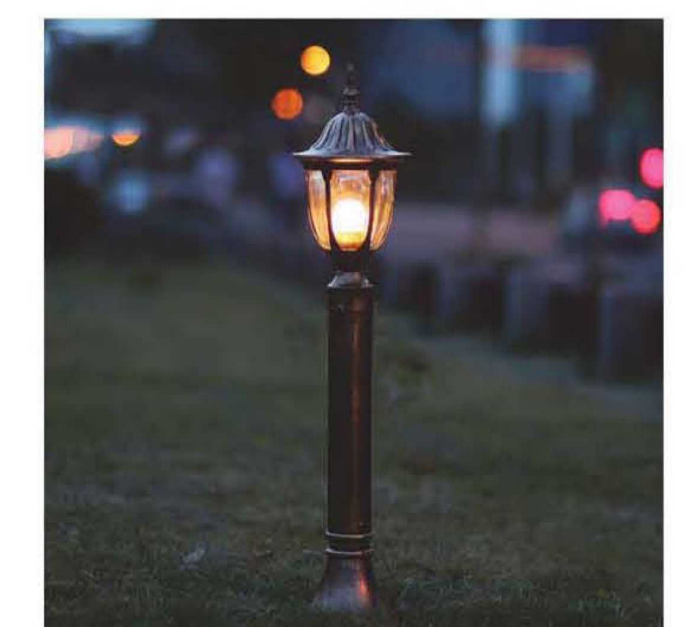
**GLZ-1**  
SINGLE-PANED STATIONARY  
GLASS SYSTEM TO MATCH  
EXISTING



**OUTDOOR LIGHTING**



**LT-2**



**LT-3**

**MATERIALS**  
Scale: NTS





- Street Tree**  
*Acer buergerianum*, Trident Maple  
medium deciduous tree
- Street Tree**  
*Laurus nobilis* 'Saratoga,' *Saratoga Bay Laurel*  
medium evergreen tree
- Interior Tree**  
*Arbutus* 'Marina,' *Strawberry Tree*  
medium evergreen tree
- Interior Tree**  
*Ceanothus* 'Ray Hartmen,' *Wild Lilac*  
small flowering evergreen tree
- Interior Tree**  
*Quercus agrifolia*, Coast Live Oak
- Landscape Berm for Screening**

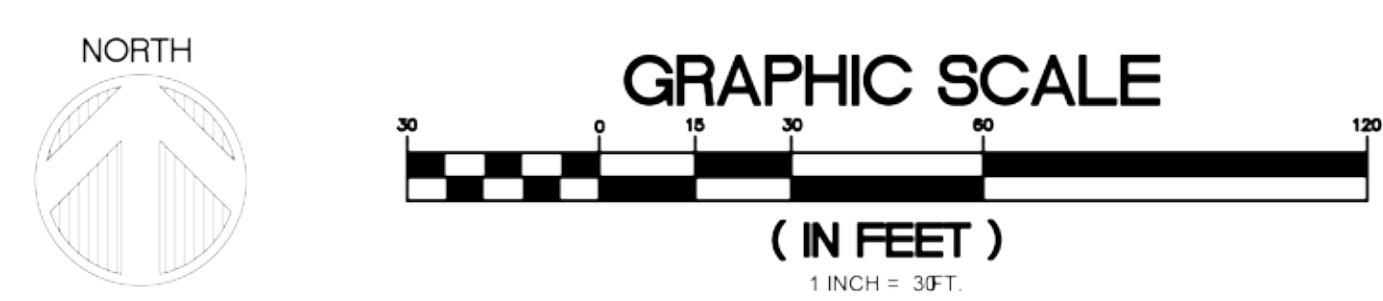
- Shrubs**  
Criteria: No wider than 8-feet, no larger than 10-feet tall at maturity, drought tolerant, native or climate adapted.  
Location: In planting areas, Landscape berm
- *Arctostaphylos densiflora*, 'Howard McMinn', Howard McMinn manzanita
  - *Ceanothus* 'Wheeler Canyon', Blue Mountain Lilac
  - *Heteromeles arbutifolia*, Toyon
  - *Mahonia* 'Golden Abundance', Oregon Grape

- Entrance Plantings**  
Criteria: Historically sensitive plantings that highlight the mission style architecture and are drought tolerant.  
Location: Pedestrian entrances
- *Iris douglasiana* 'Canyon Snow,' Douglas Iris
  - *Salvia leucantha* 'Santa Barbara,' Mexican Bush Sage
  - *Geranium Rozanne*, Rozanne geranium
  - *Frangula californica*, 'Eve Case', Eve Case coffeeberry
  - *Westingia fruticosa*, Coast Rosemary

- Ground Covers**  
Criteria: No wider than 8-feet, up to 42 inches tall, drought tolerant, native or climate adapted.  
Location: Under trees and in planting areas.
- *Arctostaphylos* 'Pacific Mist', Pacific Mist manzanita
  - *Epilobium californicum*, California fuchsia
  - *Carex divulsa*, Berkeley Sedge
  - *Eriogonum grande var. rubescens*, red-flowered buckwheat

- Detention Basin**  
Criteria: Sod to withstand periods of dry and wet conditions and adaptive to most soil conditions.  
Location: Detention Basin
- Delta Bluegrass Biofiltration Sod - Basin Bottom
  - Delta Bluegrass Native Preservation Mix - Basin Slopes

**Bay Friendly**  
This project will conform to the Bay-Friendly Scorecard for Civic, Commercial and Multifamily Landscapes Version 4 including design criteria for shaded site pavement.





Entrance Planting: *Iris douglasiana* 'Canyon Snow,' Douglas Iris



Entrance Planting: *Salvia leucantha* 'Santa Barbara,' Mexican Sage Bush



Entrance Planting: *Geranium rozanne*, Rozanne Geranium



Shrub: *Westingria fruticosa*, Coast Rosemary



Shrub: *Heteromeles arbutifolia*, Toyon



Shrub: *Arctostaphylos* 'Howard McMinn', Howard McMinn manzanita



Shrub: *Mahonia* 'Golden Abundance'



Ground Cover: *Erigeron grande* var. *rubescens*  
Red-flowered buckwheat detail



Shrub: *Frangula californica* 'Eve Case', Coffeeberry



Club Knoll Rendering



3' Diameter Planters with Citrus Trees: Example



Street Tree: *Lauris nobilis* 'Saratoga,' Saratoga Bay Laurel



*Ceanothus* 'Ray Hartman,' Wild Lilac



Interior Tree: *Arbutus* 'Marina,' Strawberry Tree



Street Tree: *Acer buergerianum*, Trident Maple



Interior Tree: *Quercus agrifolia*, Coast Live Oak

# CLUB KNOLL RELOCATION & REHABILITATION

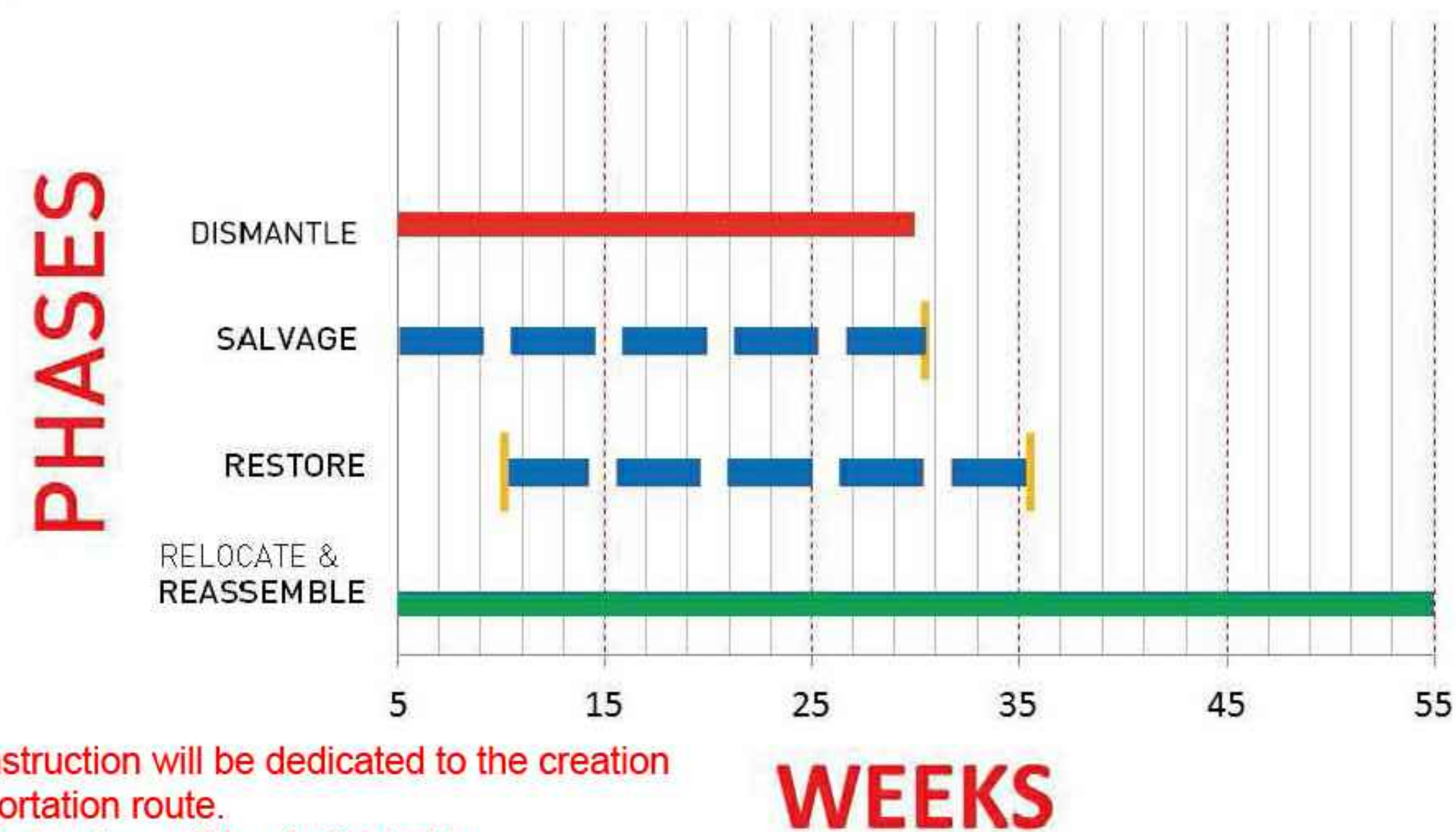


**OLD SITE \* DISMANTLE**

① MOBILIZE AND CLEAR SITE OF DEBRIS

**WEEK 3**

## SCHEDULE

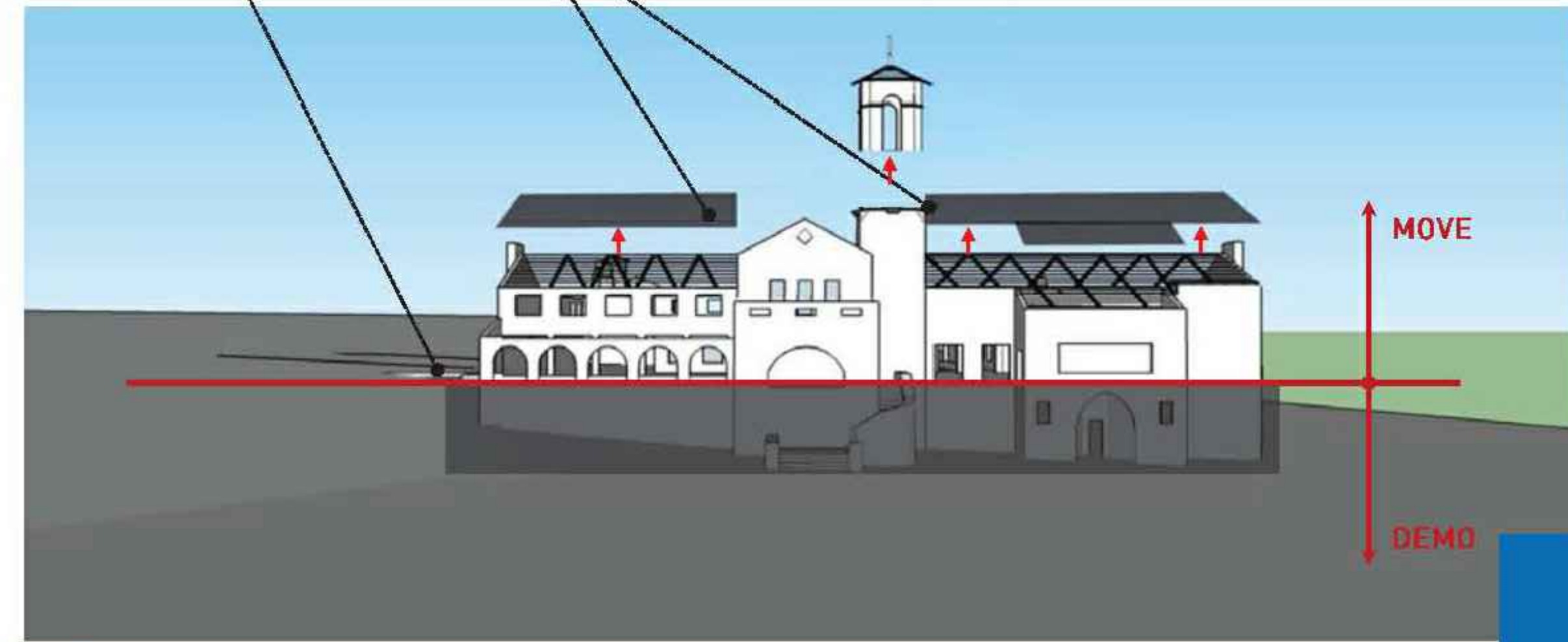
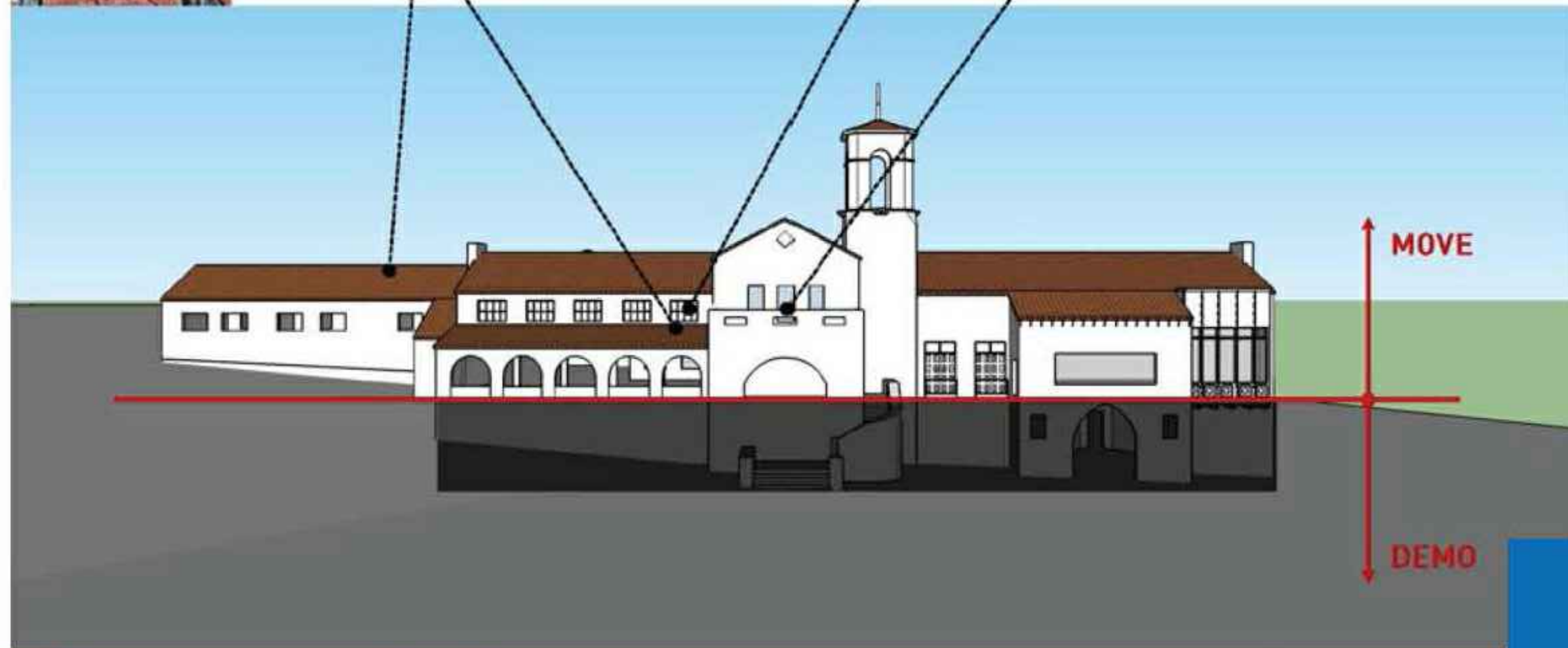


\* 3 months Pre- Construction will be dedicated to the creation of a Temp. Transportation route.  
3 months Post- Construction will be dedicated to demo of Temp. Transportation route.

**NEW SITE \* RELOCATE & REASSEMBLE**



MOBILIZE CONSTRUCTION AND CREATE SALVAGE YARD AT NEW SITE



2 SALVAGE ROOF TILE, WINDOWS, AND DOORS

WEEK 7

3 DEMO SIDE WING, ROOF SHEATHING REMOVE SALVAGE AND MOVE TOWER

WEEK 10



GRADING AND UNDERGROUND UTILITIES



UNDER-SLAB UTILITIES/ UNDERGROUND UTILITIES

ARCHITECTURAL  
DIMENSIONS

300 Frank H. Ogawa Plaza, Suite 375  
Oakland, CA 94612  
TEL. 510.463.8300 • FAX. 510.463.8395

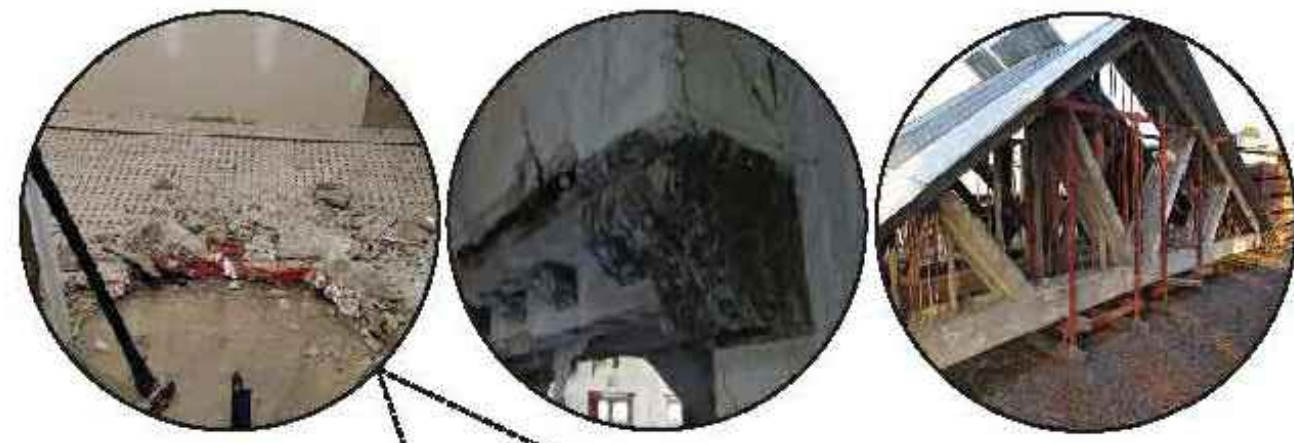
PROJECT INFO.

CLUB KNOLL  
MOUNTAIN BLVD. & SEQUOYAH RD  
OAKLAND, CA. 94605

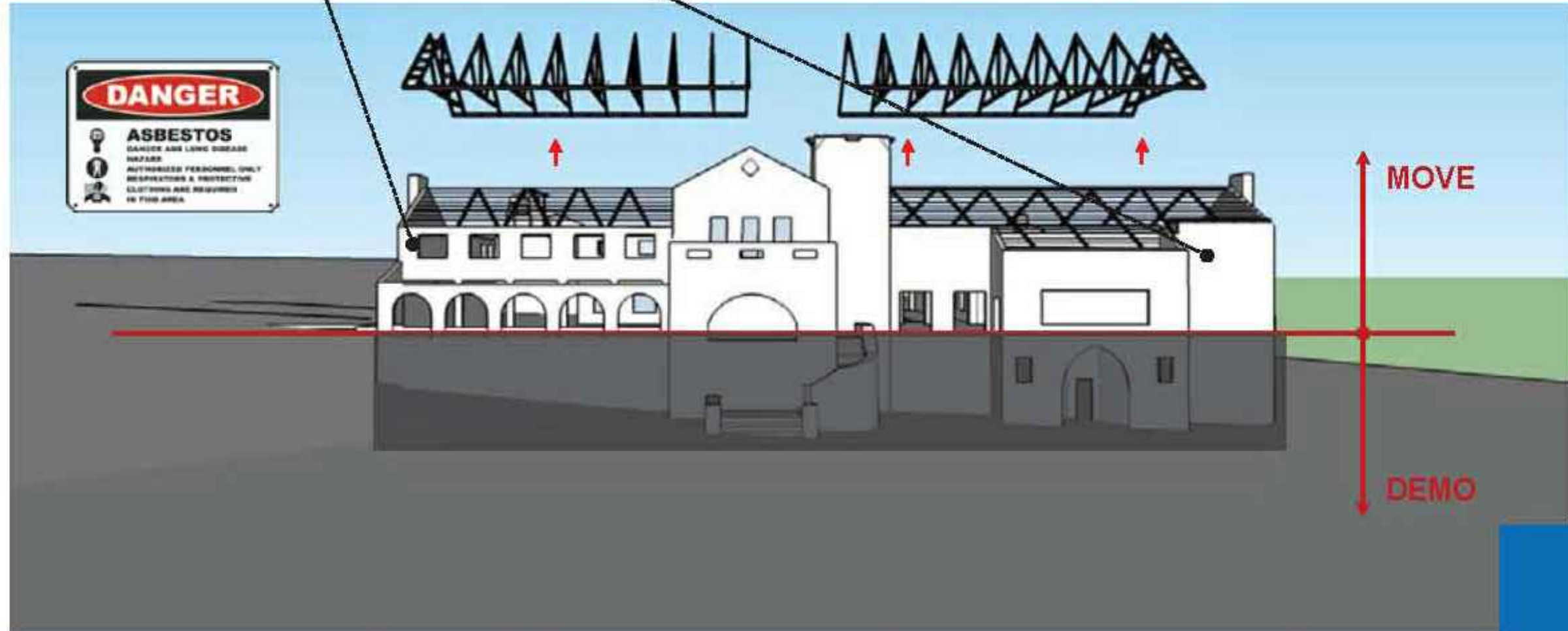
METHODOLOGY  
OF RELOCATION

JOB NO.  
SC002  
DATE:  
01.27.2017

DRAWING NO.  
DR-12.2



- SALVAGE LIST**
- Trusses
  - Millwork
  - Flooring
  - Railings



**4 DEMO INTERIOR SYSTEMS/SALVAGE PARTS**

**WEEK 16**



**5 SHORE BUILDING/SCAFFOLD/BRACE**

**WEEK 26**



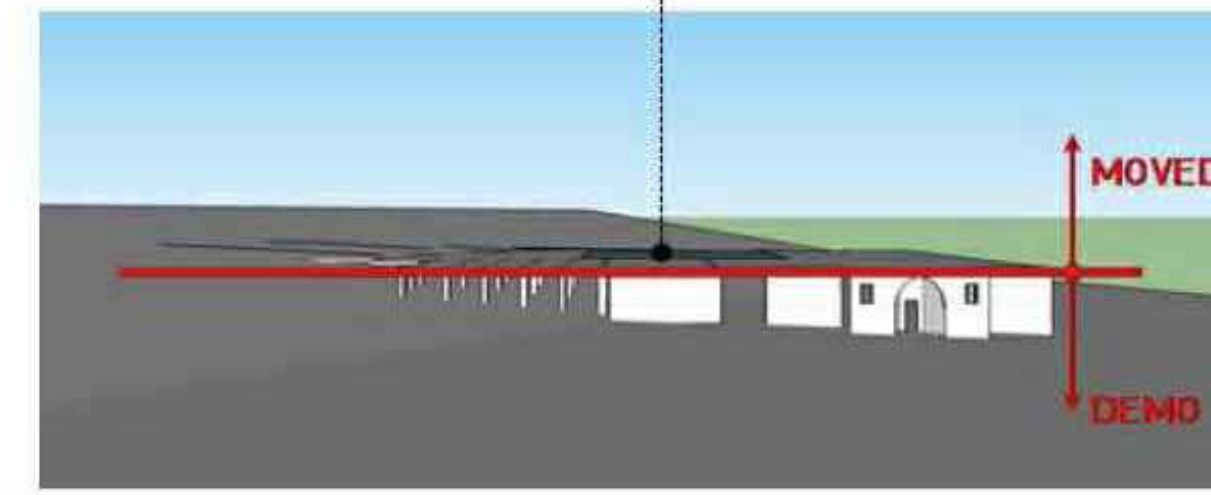
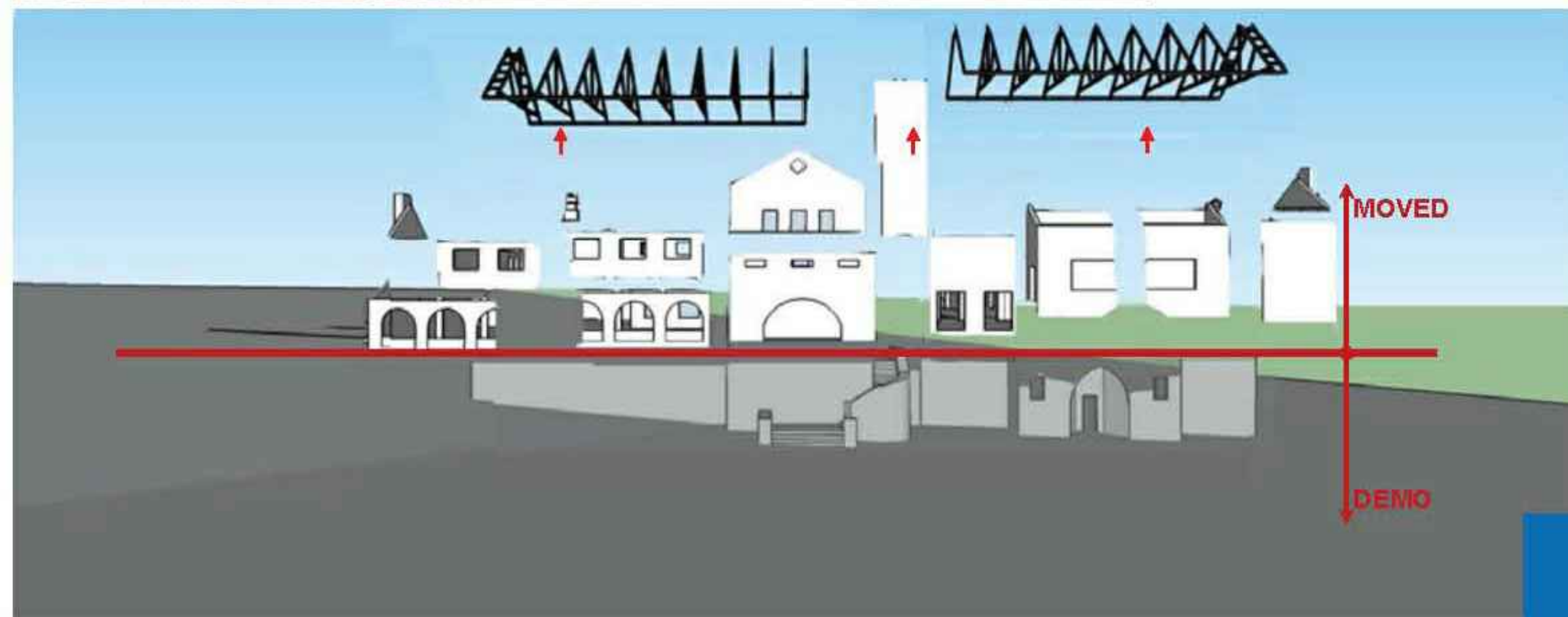
**FOUNDATION AND SLAB CONSTRUCTION**



**BUILD STEEL SKELETON / ASSEMBLE COMPONENTS**



END OF  
DISMANTLEMENT

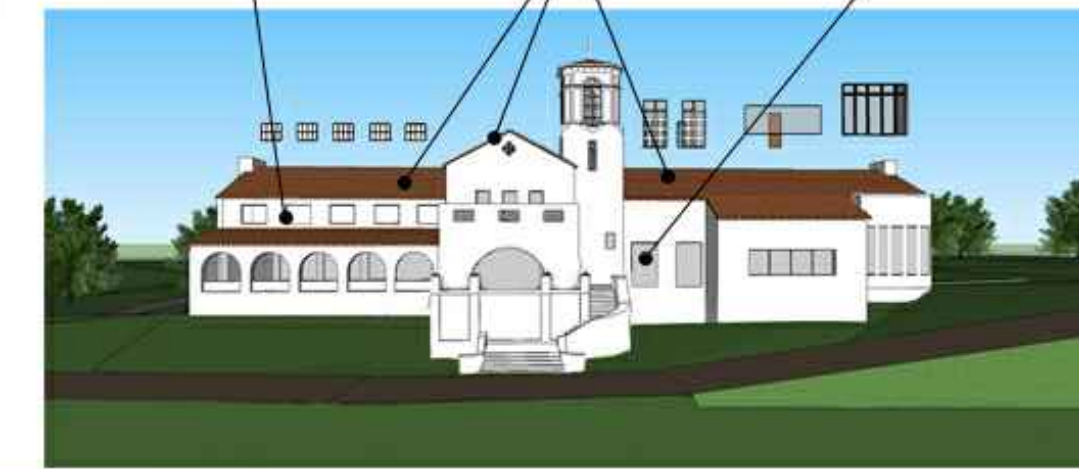
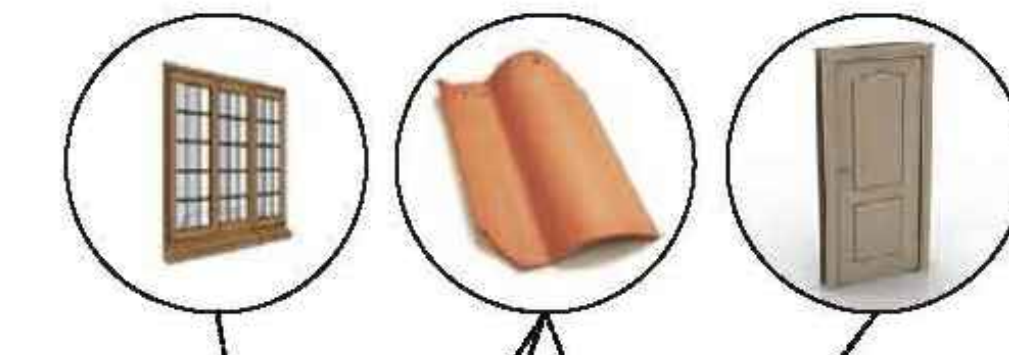
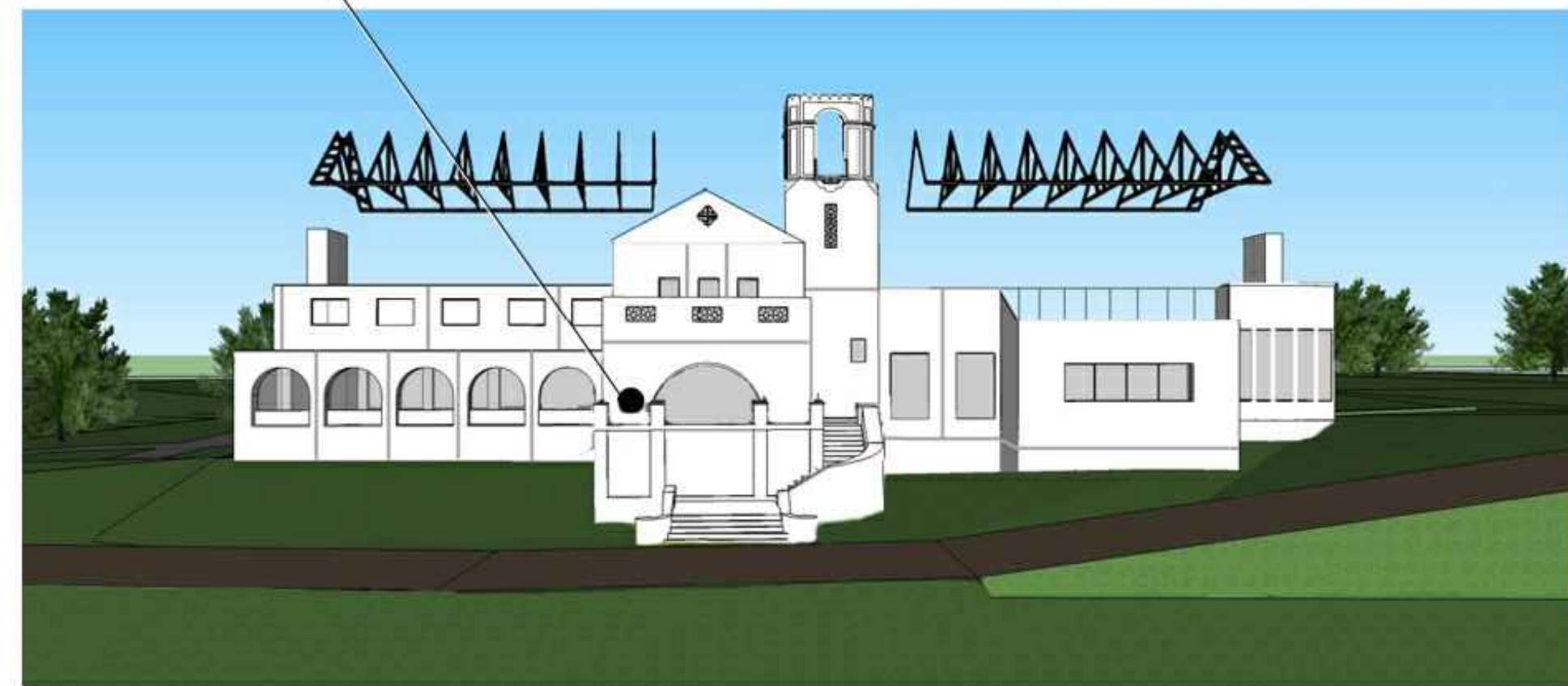


6 COMPONENTS DISMANTLED AND MOVED

WEEK 30



7 DEMO LOWER LEVEL / FILL AND GRADING



REASSEMBLY OF WALLS CONTINUES / REINSTALL ROOF TRUSSES



REASSEMBLE SALVAGED COMPONENTS AND PARTS, SUCH AS, ROOF TILE, WINDOWS, AND DOORS

ARCHITECTURAL  
DIMENSIONS

300 Frank H. Ogawa Plaza, Suite 375  
Oakland, CA 94612  
TEL. 510.463.8300 • FAX. 510.463.8395

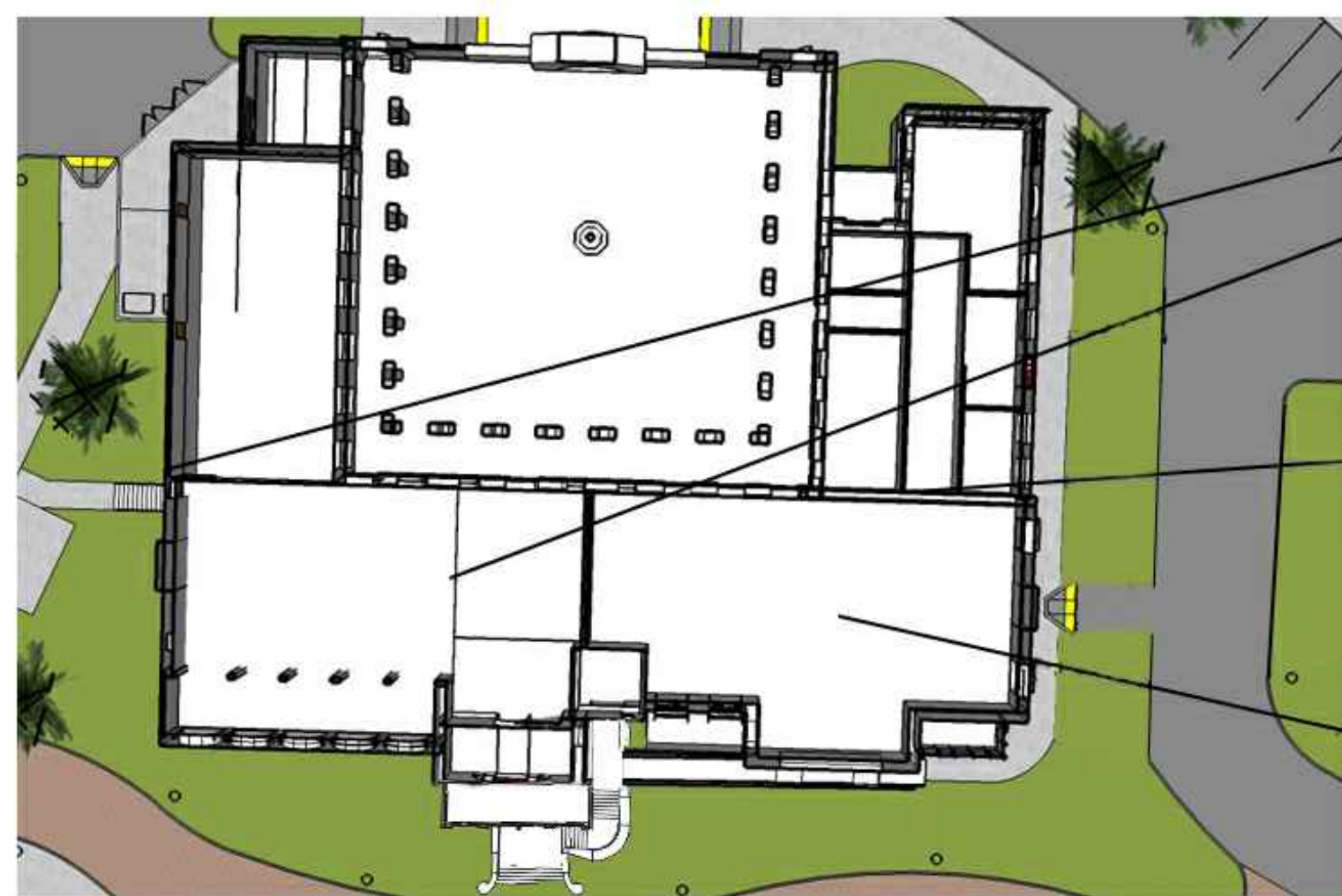
PROJECT INFO.

CLUB KNOLL  
MOUNTAIN BLVD. & SEQUOYAH RD  
OAKLAND, CA. 94605

METHODOLOGY  
OF RELOCATION

JOB NO.  
SC002  
DATE:  
01.27.2017

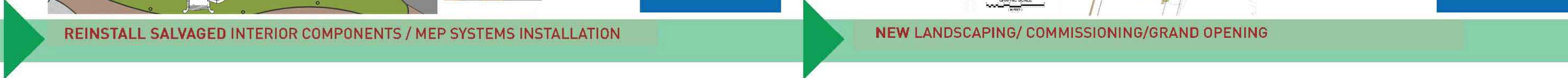
DRAWING NO.  
DR-12.4



WEEK 45



WEEK 55



**ARCHITECTURAL  
DIMENSIONS**

300 Frank H. Ogawa Plaza, Suite 375  
Oakland, CA 94612  
TEL. 510.463.8300 • FAX. 510.463.8395

PROJECT INFO.

**CLUB KNOLL**  
MOUNTAIN BLVD. & SEQUOYAH RD  
OAKLAND, CA. 94605

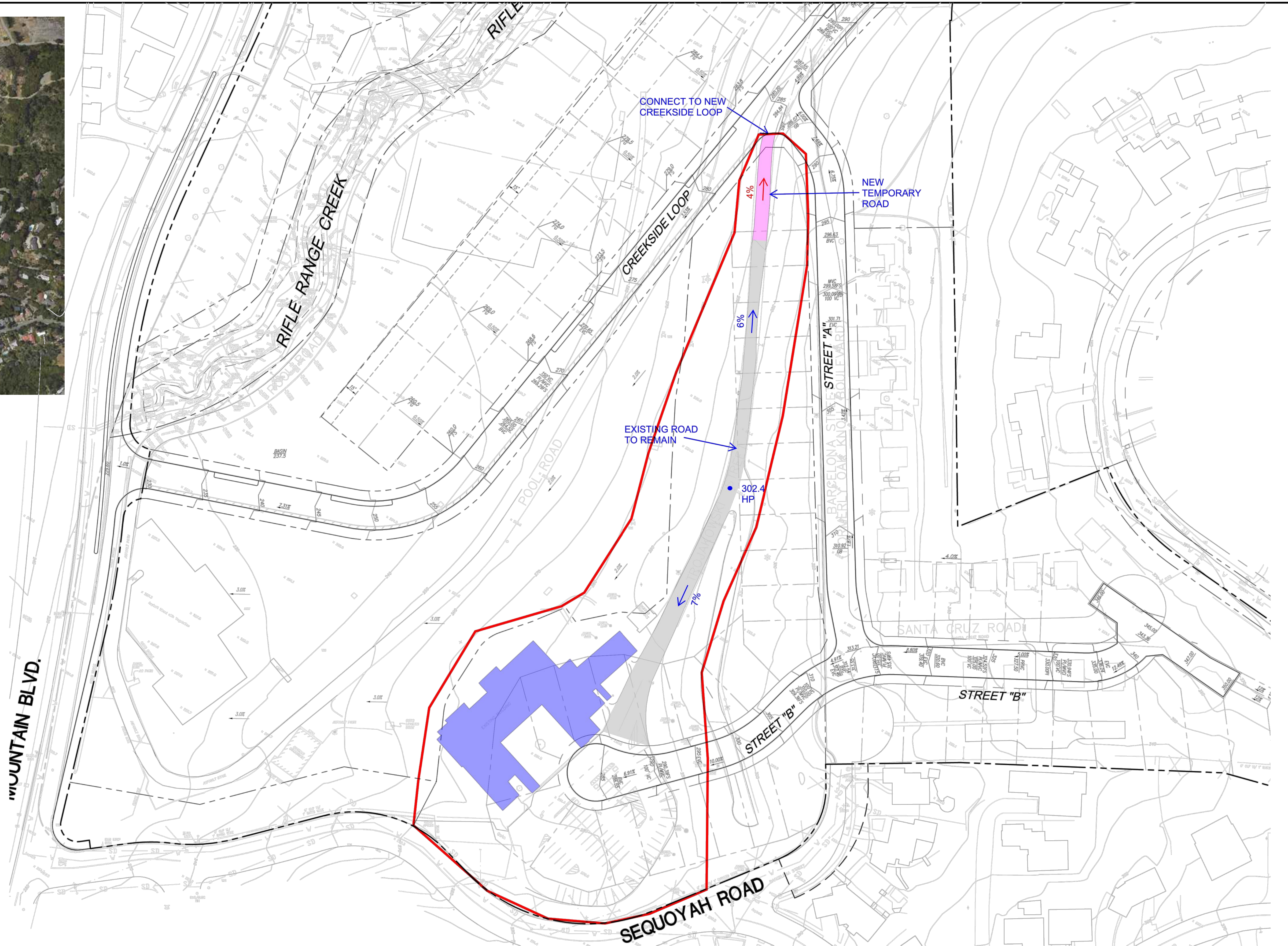
**METHODOLOGY  
OF RELOCATION**

JOB NO.  
**SC002**  
DATE:  
**01.27.2017**

DRAWING NO.  
**DR-12.5**



AERIAL VIEW



\* REMAINDER OF ROUTE  
WILL FOLLOW CREEKSIDE  
LOOP TO NEW SITE



**CLUB KNOLL**  
**Relocation and Replacement**  
**Matrix By Building Part/Component**

	%	%	%	%	%	EXPLANATION	METHOD OF REPLACEMENT
BUILDING COMPONENTS	EXISTING	TO BE	INTACT	TO REPLACE	TO REPLACE		
		RELOCATED	AFTER MOVE	DAMAGED	MISSING		
				DURING MOVE	NOW		
<b>INTERIOR</b>							
MECHANICAL SYSTEM	0	0	0	0	100	All New Systems	All New Systems
ELECTRICAL SYSTEM	0	0	0	0	100	All New Systems	All New Systems
SPRINKLER SYSTEM	0	0	0	0	100	All New Systems	All New Systems
PLUMBING SYSTEM	0	0	0	0	100	All New Systems	All New Systems
LIGHT FIXTURES	0	0	0	0	100	All New Systems	All New Systems
INTERIOR PLASTER/ DECORATIVE STUCCO	90	0	0	0	100	Deteriorated and Hazmat Content	All New Systems
HARDWARE	0	0	0	0	100	All hardware missing	Purchase new Hardware of same style
FIRE PLACES/Chimneys	100	100	85	15	0	Repoint Grout Loss	New Grout as Needed by Mason
ROOF TRUSSES	100	100	100	0	0		
WOOD CORBELS	90	90	90	0	10	Missing to be Replaced	Made by Casework Vendor to Match
PLASTER COLUMNS	90	90	90	10	0		
INTERIOR WOOD RAILINGS	90	90	90	0	10	Missing to be Replaced	Made by Casework Vendor to Match
WOOD CEILING	100	100	80	20	0	There is some existing damage due to water intrusion.	
DOORS	80	40	40	0	0	All doors may not be needed	
GRAFITTI	100	0	0	0	0	Not original	
WOOD FLOOR + BASEBOARDS	100	100	60	40	0	Existing damage at around 40% of flooring	
<b>EXTERIOR</b>							
EXTERIOR PLASTER/ DECORATIVE STUCCO	90	90	90	10	0	Damage to be Replaced	Patching by Plaster Contractor
EXTERIOR METAL RAILINGS	90	90	90	0	10	Missing to be Replaced	Made by Metal Fab Vendor to Match
DOORS	50	50	30	0	70	Missing to be Replaced	Made by Casework Vendor to Match
DOOR FRAMES	80	80	50	0	50	Missing to be Replaced	Made by Casework Vendor to Match
DOOR HARDWARE	0	0	0	0	100	Missing to be Replaced	Made by Casework Vendor to Match
WINDOWS FRAMES	90	90	75	15	10	Missing to be Replaced	Made by Casework Vendor to Match
GLASS	35	20	20	0	80	Missing to be Replaced	New Glass by Glazing Contractor
STRUCTURAL WOOD FRAME	100	90	90	10	0	Replace Dry Rot	Repairs by Framing Contractor
ROOF TILES	75	100	60	40	0	Use salvaged spare tiles from 3rd wing	Work by Roofing Contractor
FIREPLACE	100	100	90	10	0	Replace lost grout	New Grout as Needed by Mason
ROOF BRACKETS	50	50	50	0	50	Missing to be Replaced	Made by Metal Fab Vendor to Match
<b>APPROACH TO REPAIR AND REPLACEMENT OF PARTS</b>							
1. Salvaged parts will be cleaned and/or refinished either at the new building site or in shops of vendors that have appropriate expertise.							
2. Missing mechanical parts such as light fixtures and hardware will be purchased from manufacturers that have products that "match" existing style.							
3. Missing parts that can be fabricated locally like metal and wood railings, doors, windows, corbels, etc. will be fabricated by vendors that have appropriate expertise.							
4. Missing or damaged systems that have contemporary contractors or vendors of appropriate expertise will be used for trades like framing, plaster, mechanical, plumbing, electrical.							
5. All parts and systems will be inventoried and defined for reuse and repair as part of the construction documents to be permitted by the City.							
6. All parts and systems will be inspected and tracked during construction on process of rehabilitation and reuse.							





FRONT ELEVATION- NEW SITE



LOOKING NORTH AT EYE LEVEL- NEW SITE



LOOKING WEST PERSPECTIVE- NEW SITE



LOOKING SOUTH PERSPECTIVE- NEW SITE



VIEW FROM CREEKSIDE LOOP BRIDGE- NEW SITE



VIEW FROM MTN. BLVD ENTRANCE- NEW SITE



MASTER PLAN- PROPOSED OAK KNOLL DEVELOPMENT



MASTER PLAN- 3D MODEL- PROPOSED OAK KNOLL DEVELOPMENT



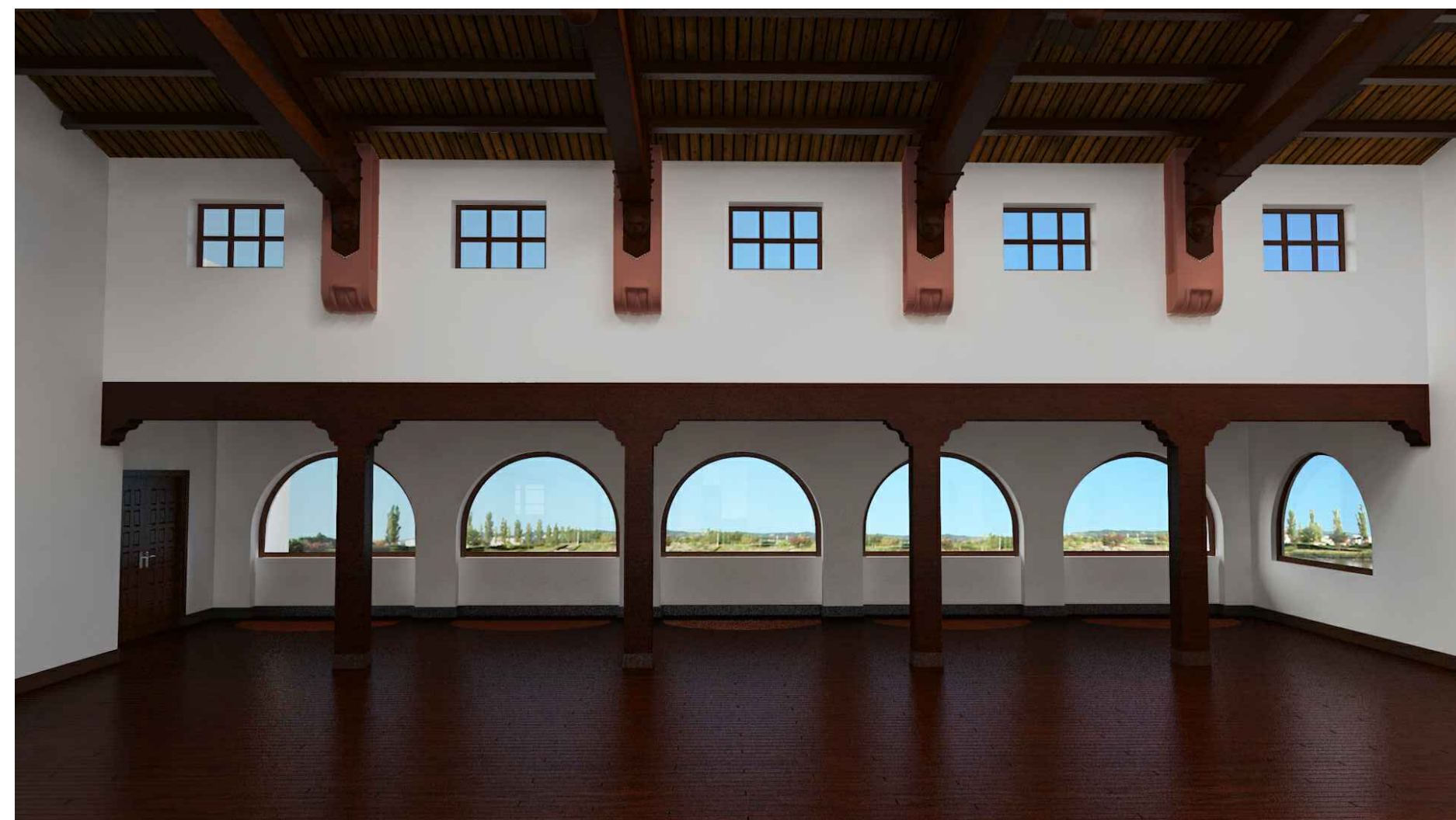
GRAND HALL EAST



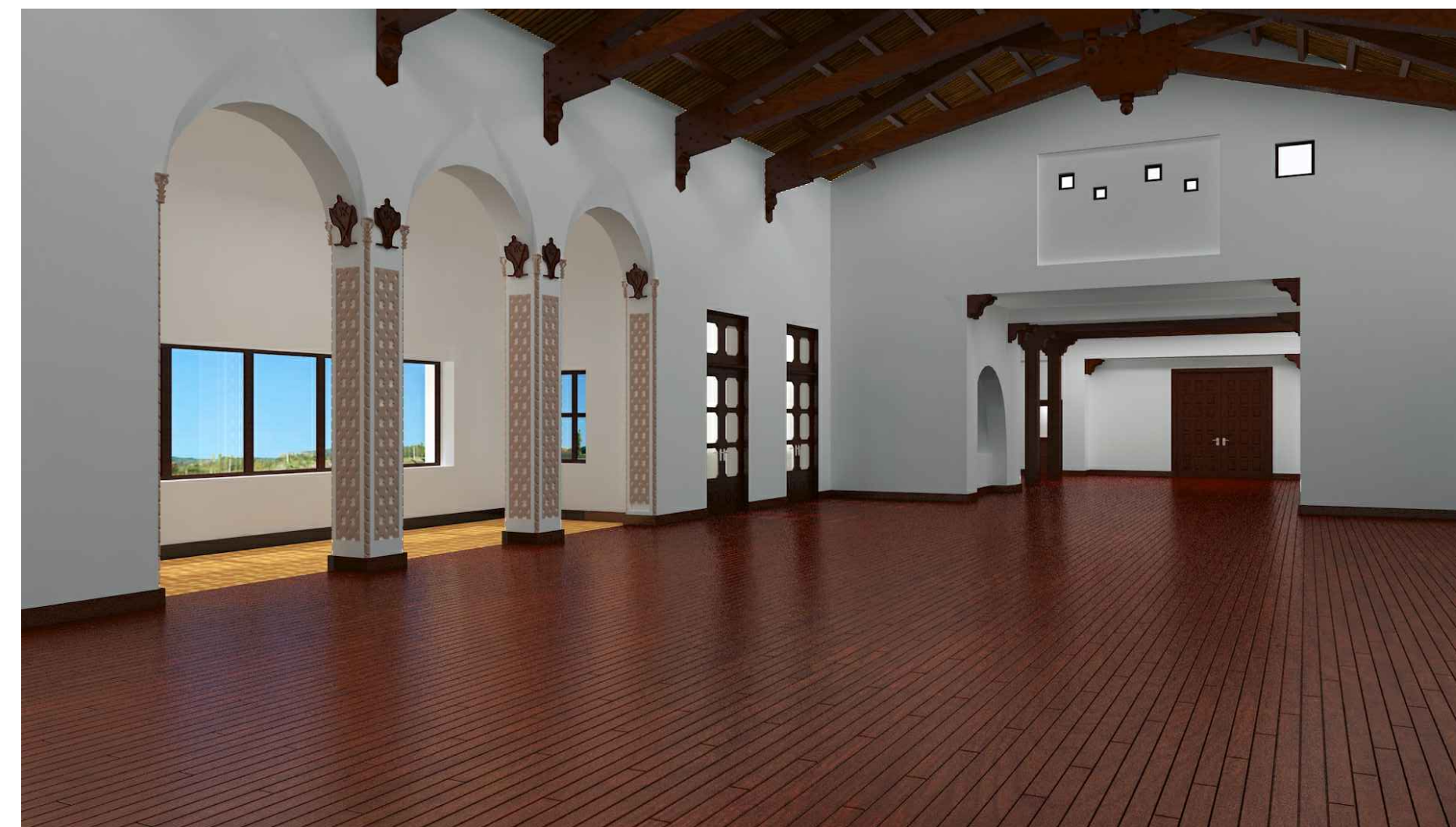
ENTRY



DINING HALL SOUTH



DINING HALL WEST



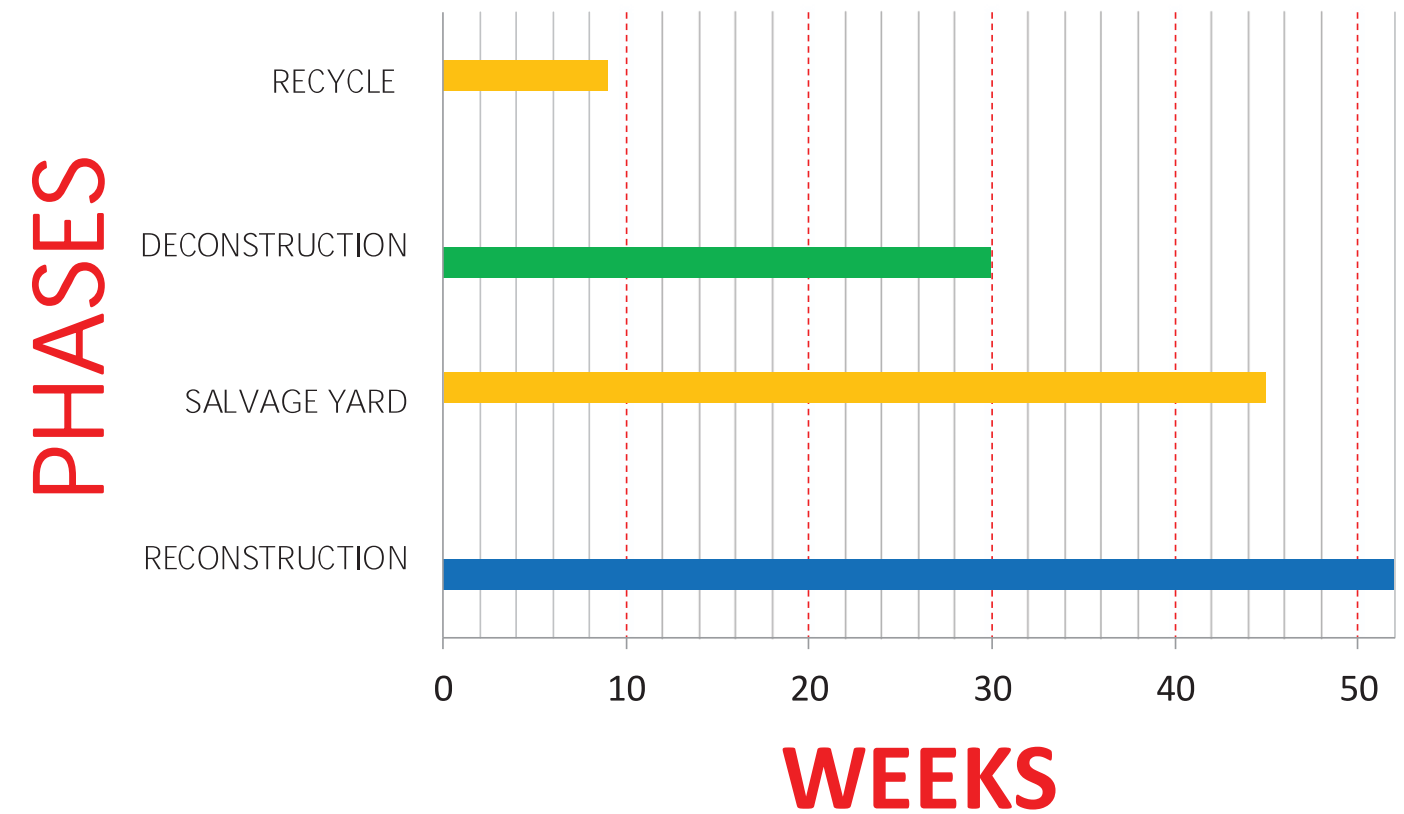
GRAND HALL NORTH



DINING HALL NORTH

NOTE:  
 INTERIOR VIEWS REFLECT UNDERSTANDING OF  
 ORIGINAL DESIGN, NOT FUTURE BUILDING USE.

# CLUB KNOLL RELOCATION & REHABILITATION

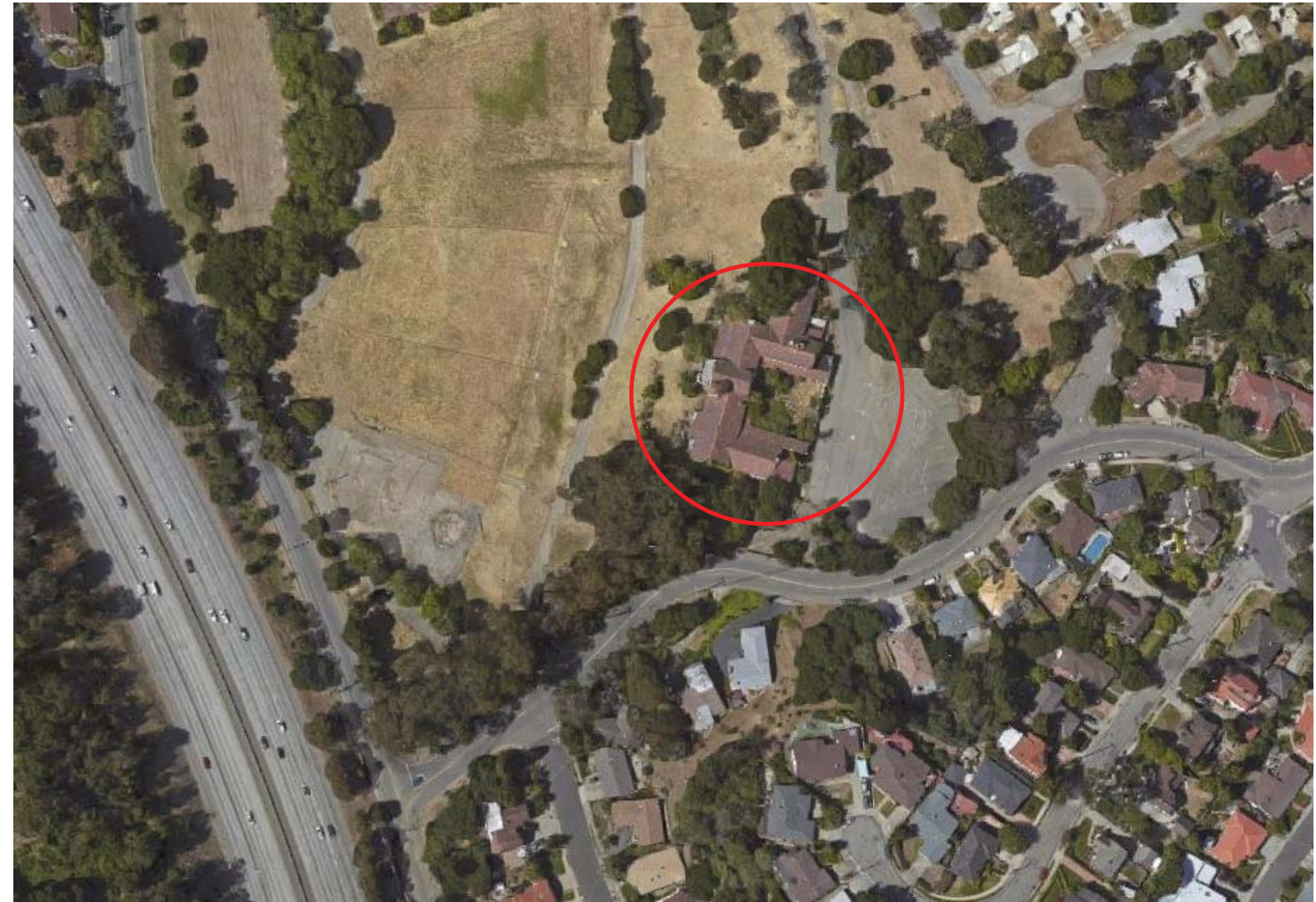


\* 3 months Pre-Construction will be dedicated to the creation of a Temp. Transportation route.  
3 months Post- Construction will be dedicated to demo of Temp. Transportation route.



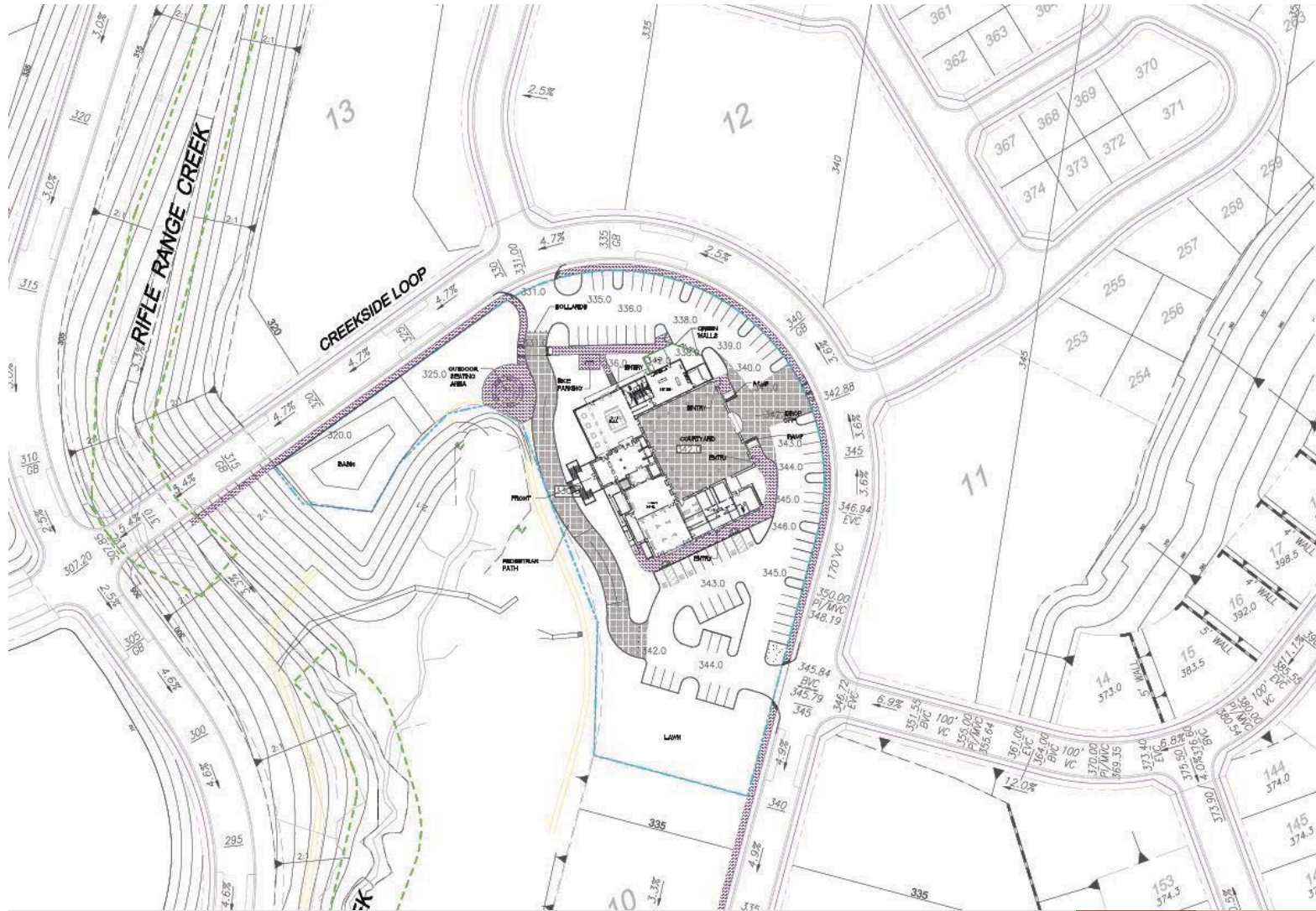
PROPOSED RELOCATION

ARCHITECTURAL  
DIMENSIONS



EXISTING BUILDING AERIAL

ARCHITECTURAL  
DIMENSIONS



PROPOSED BUILDING SITE PLAN

ARCHITECTURAL  
DIMENSIONS



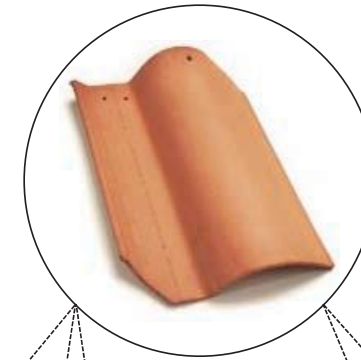
1 MOBILIZE AND CLEAR SITE



ARCHITECTURAL  
DIMENSIONS

WEEKS 1 - 2





WEEKS 3 - 4



MOBILIZE AND CREATE SALVAGE YARD

ARCHITECTURAL  
DIMENSIONS

2 SALVAGE ROOF TILE

ARCHITECTURAL  
DIMENSIONS



GRADING

ARCHITECTURAL  
DIMENSIONS



WEEKS 5 - 6



3 SALVAGE WINDOWS AND DOORS

ARCHITECTURAL  
DIMENSIONS



UNDERGROUND UTILITIES

ARCHITECTURAL  
DIMENSIONS



WEEK 7



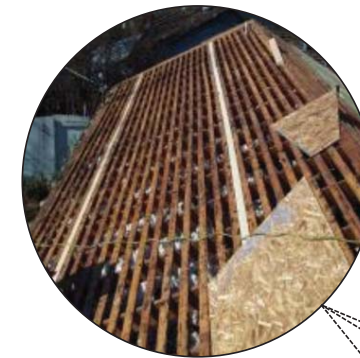
④ DEMO SIDE WING / RECYCLE DEMO

ARCHITECTURAL  
DIMENSIONS

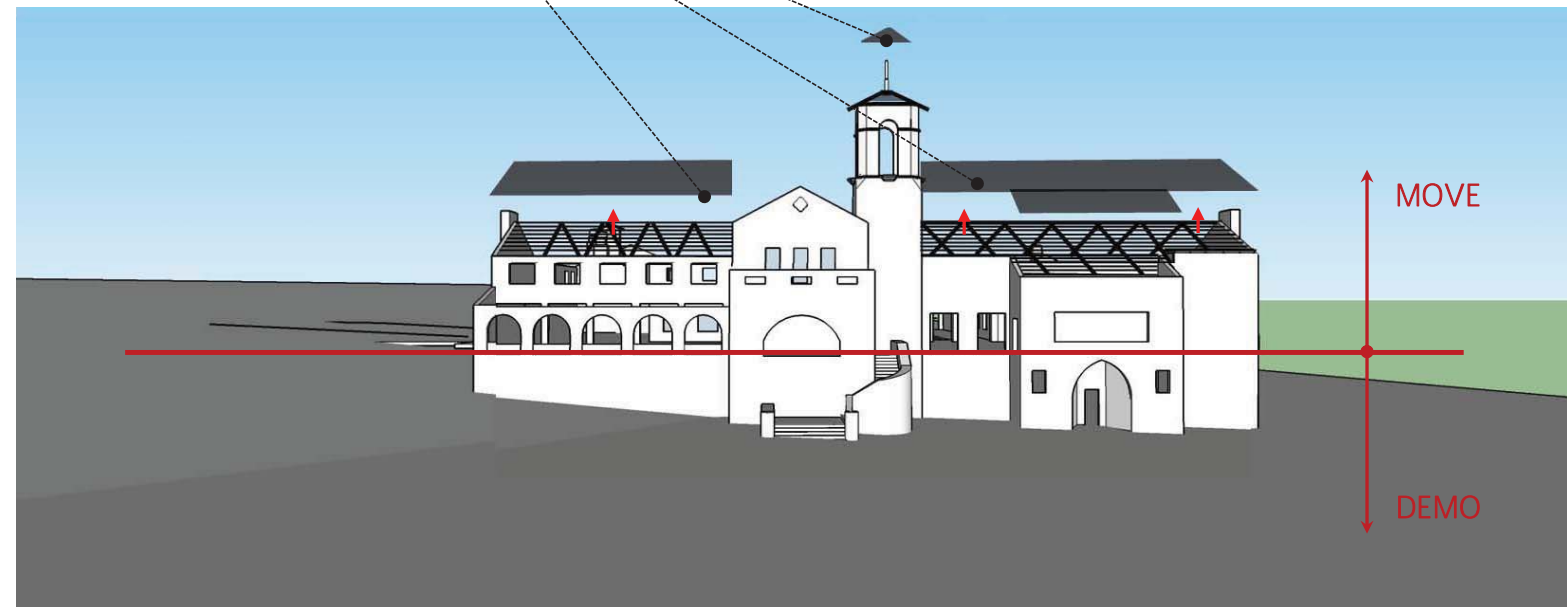


UNDERGROUND UTILITIES

ARCHITECTURAL  
DIMENSIONS



WEEKS 8 - 9



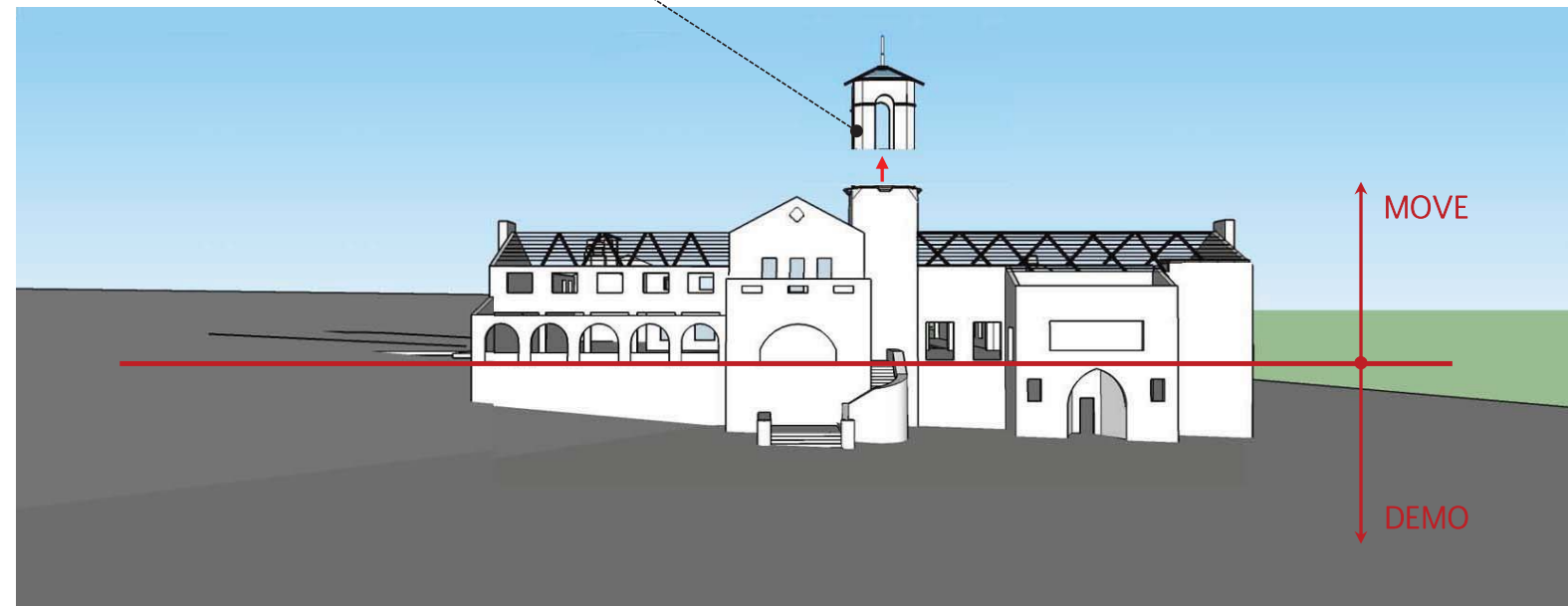
5 DEMO ROOF SHEATHING / RECYLCE DEMO

ARCHITECTURAL  
DIMENSIONS



UNDER-SLAB UTILITIES

ARCHITECTURAL  
DIMENSIONS



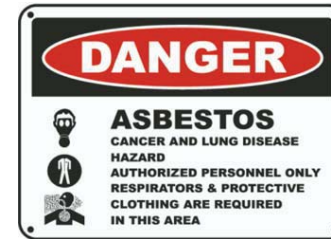
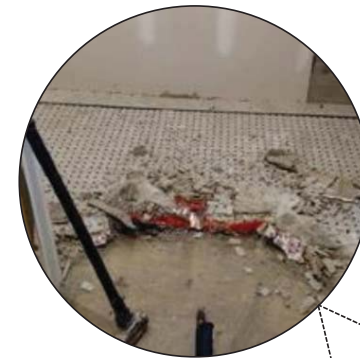
⑥ REMOVE TOP OF TOWER / SALVAGE

ARCHITECTURAL  
DIMENSIONS



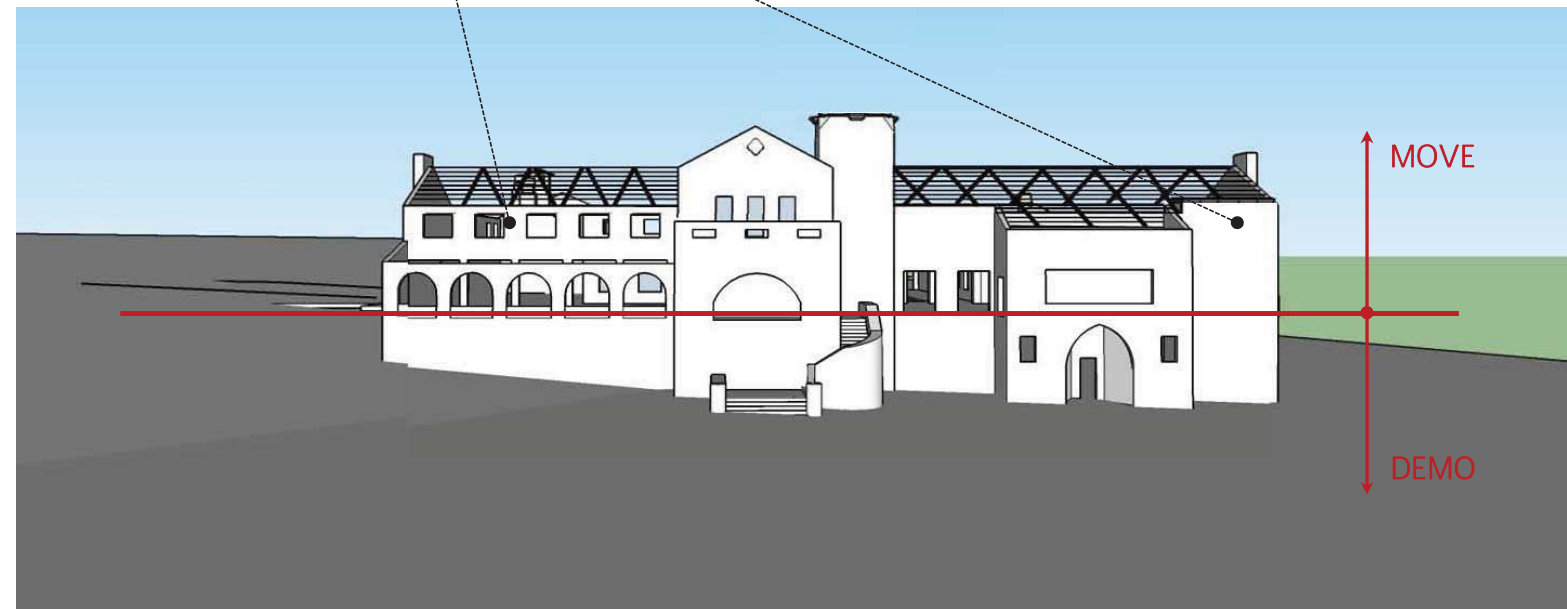
UNDER-SLAB UTILITIES

ARCHITECTURAL  
DIMENSIONS



- DEMO LIST
- Electrical
  - Mechanical
  - Plumbing

WEEKS 11-12



7 DEMO INTERIOR SYSTEMS

ARCHITECTURAL  
DIMENSIONS



FOUNDATION FORMING

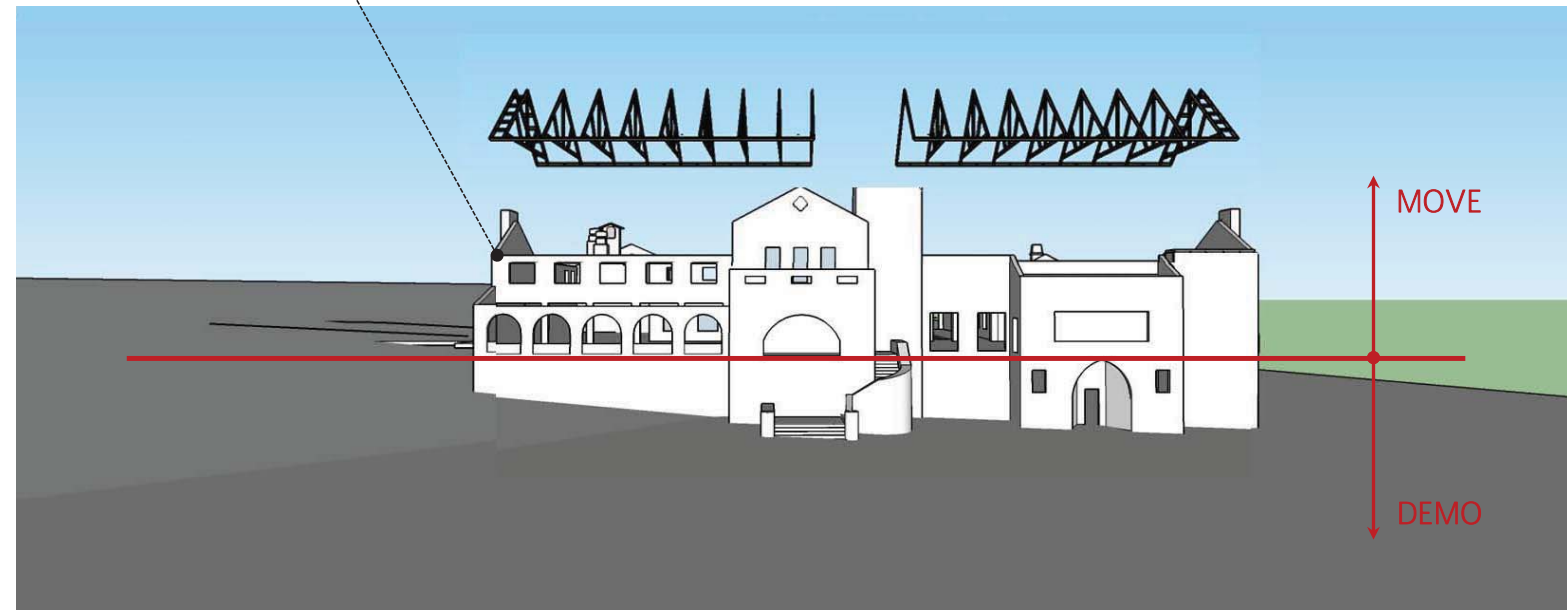
ARCHITECTURAL  
DIMENSIONS



WEEKS 13-16

SALVAGE LIST

- Trusses
- Millwork
- Wood Flooring
- Railings



8 SALVAGE INTERIOR FINISHES

ARCHITECTURAL  
DIMENSIONS

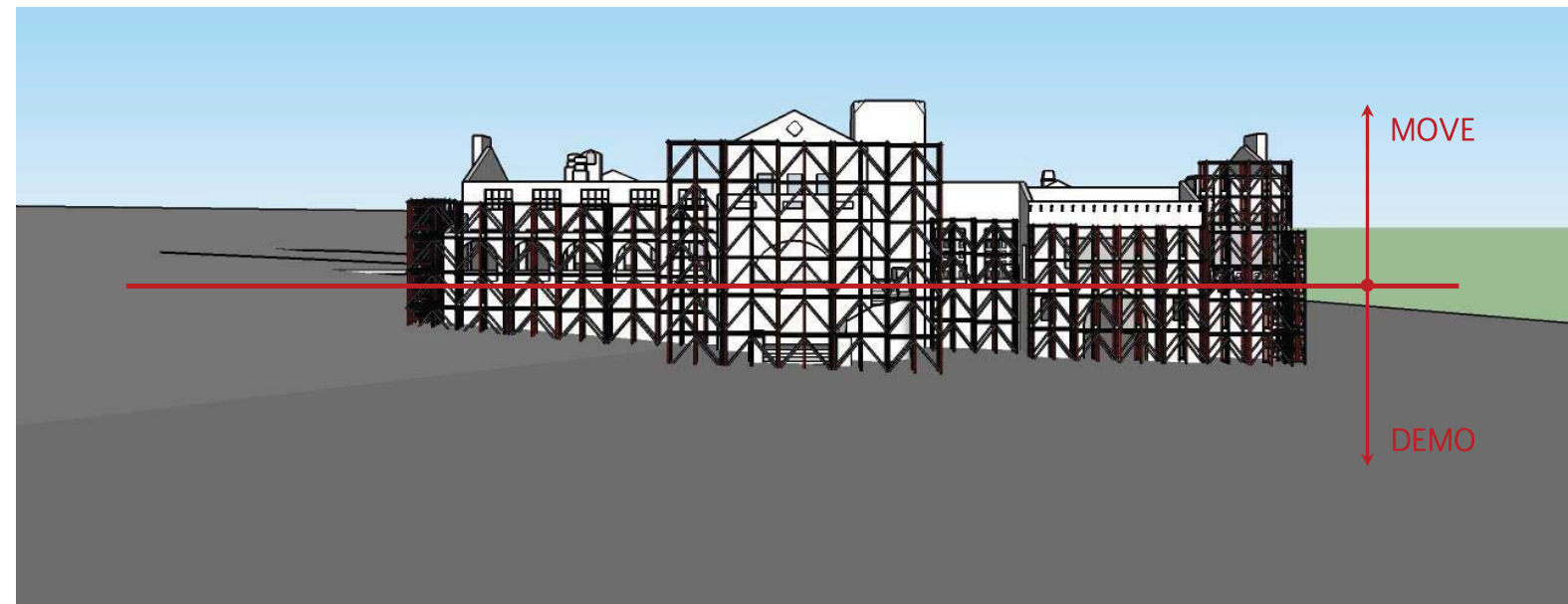


FOUNDATION FORMING

ARCHITECTURAL  
DIMENSIONS



WEEKS 17-19



9 SHORE BUILDING/SCAFFOLD/BRACE

ARCHITECTURAL  
DIMENSIONS





BUILD STEEL SKELETON

ARCHITECTURAL  
DIMENSIONS



10 FIELD INVESTIGATION



ARCHITECTURAL  
DIMENSIONS



BUILD STEEL SKELETON

ARCHITECTURAL  
DIMENSIONS



WEEKS 23-26

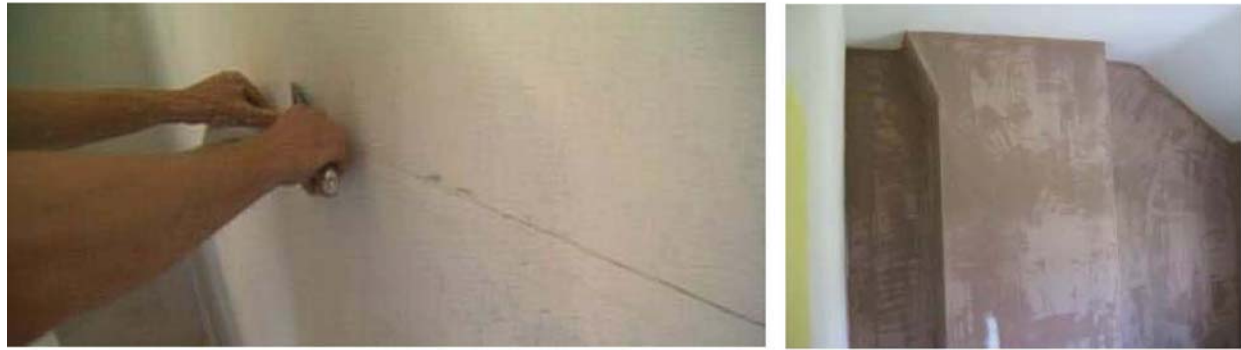
SALVAGE

- Walls
- Columns
- Tower



11 CUT AND SALVAGE WALLS

ARCHITECTURAL  
DIMENSIONS

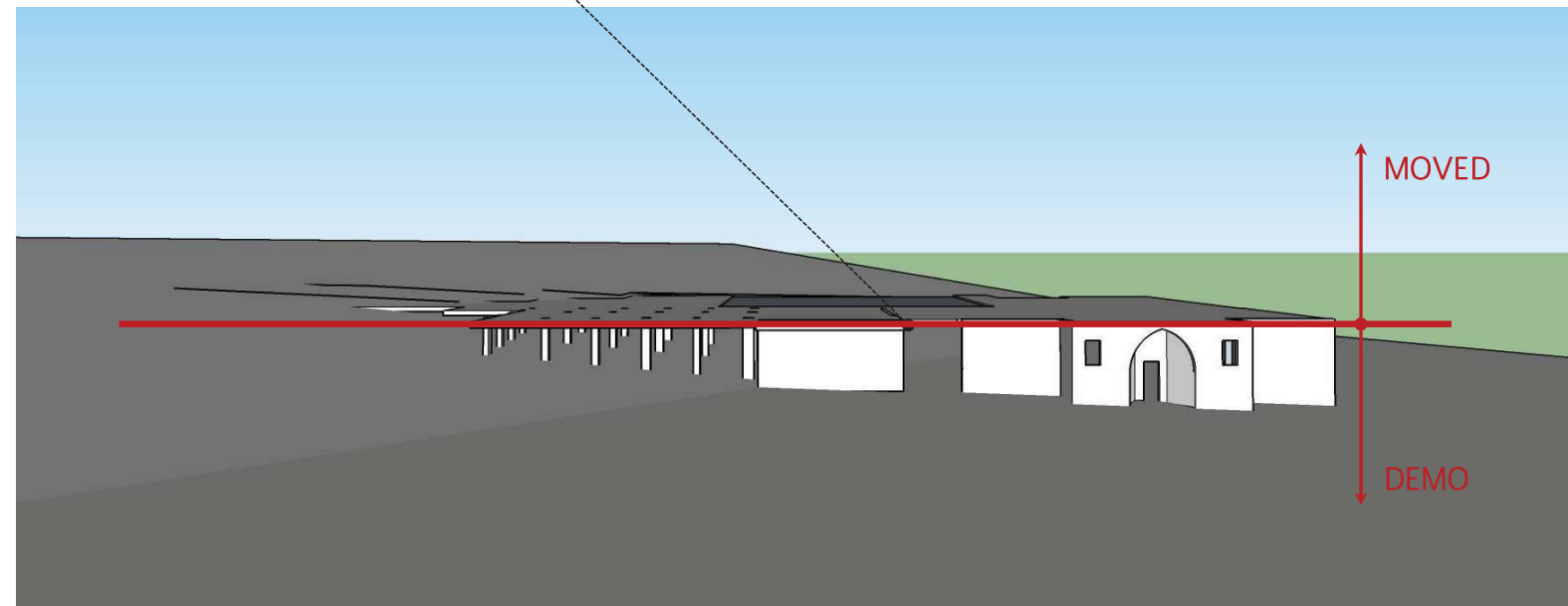


RECONSTRUCT WALLS

ARCHITECTURAL  
DIMENSIONS



WEEKS 27-28



12 DEMO LOWER LEVEL

ARCHITECTURAL  
DIMENSIONS



RECONSTRUCT WALLS

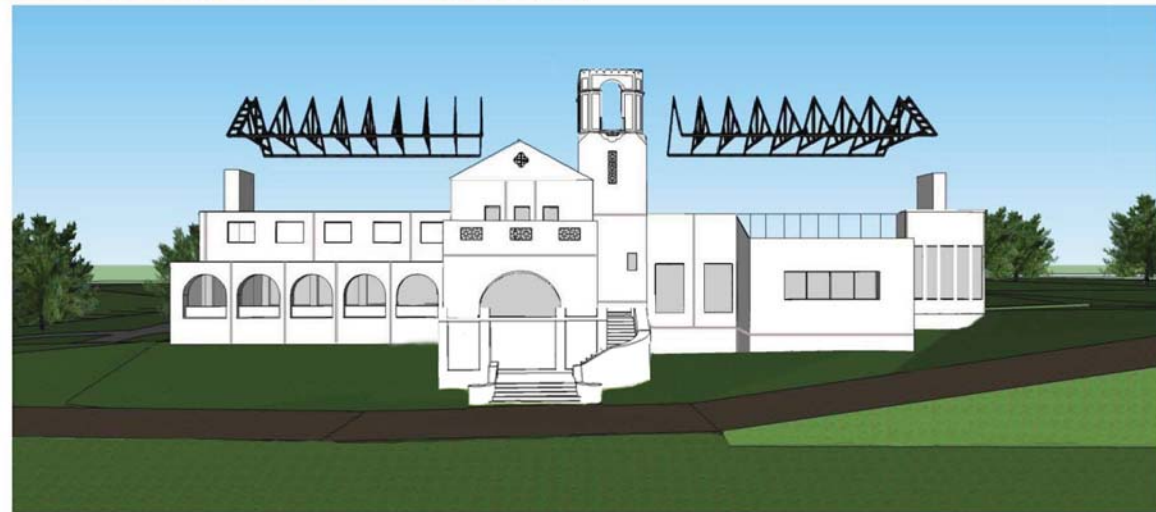
ARCHITECTURAL  
DIMENSIONS



13 FILL AND GRADING

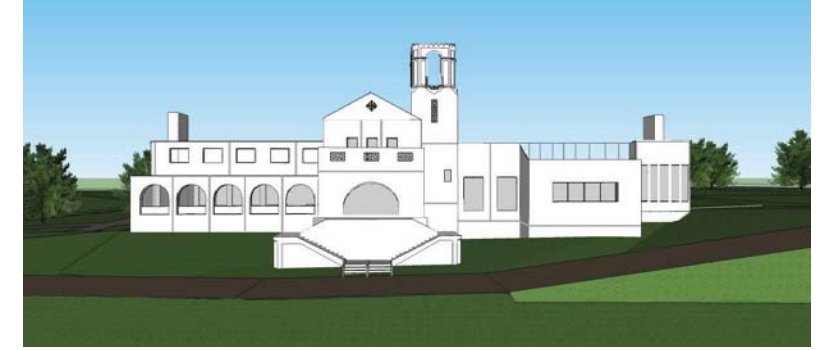
ARCHITECTURAL  
DIMENSIONS

WEEKS 29-30



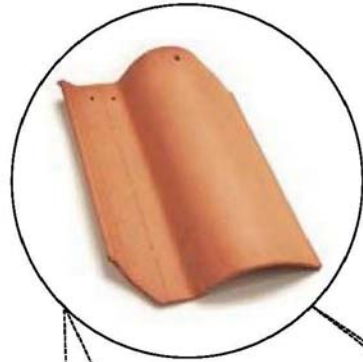
REINSTALL ROOF TRUSSES

ARCHITECTURAL  
DIMENSIONS



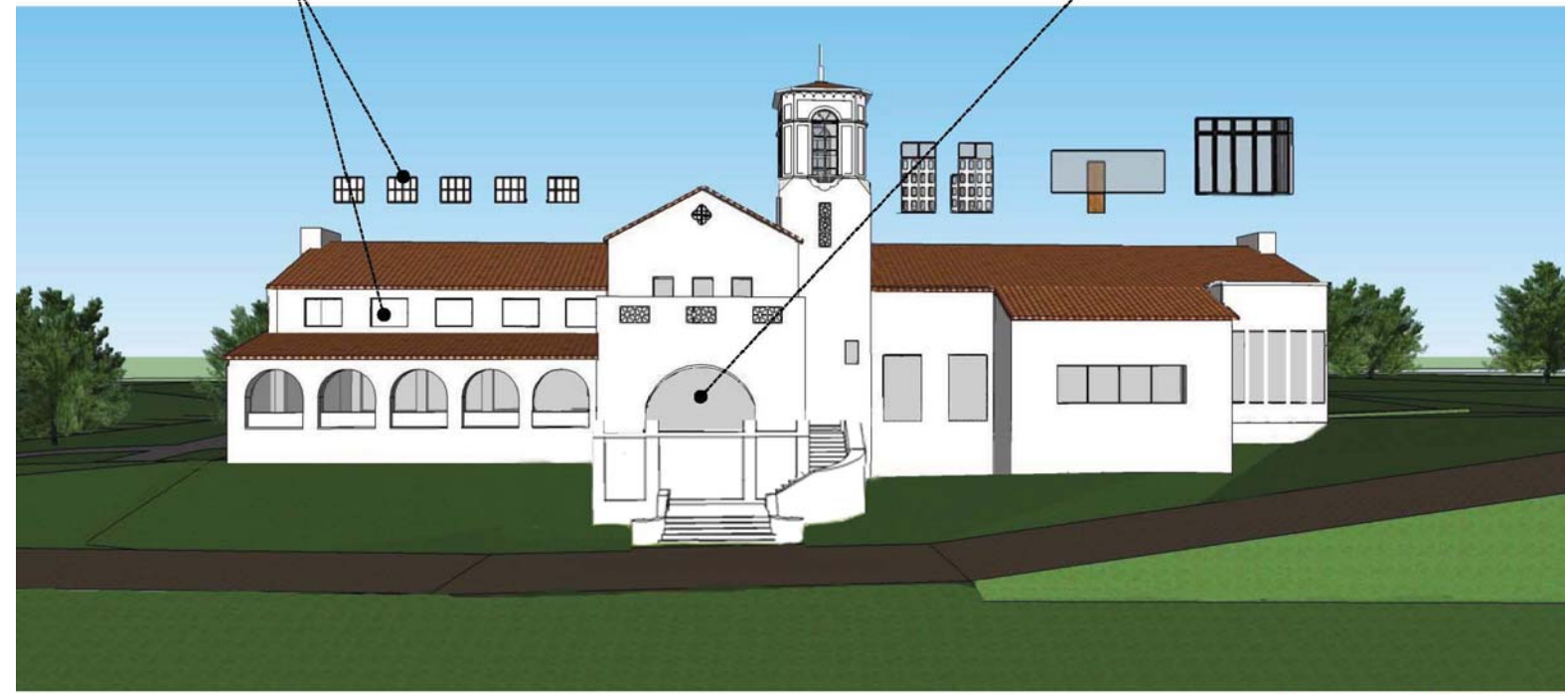
STICH FRAMING

ARCHITECTURAL  
DIMENSIONS



REINSTALLATION OF ROOF TILE

ARCHITECTURAL  
DIMENSIONS



REINSTALL EXISTING WINDOWS AND DOORS

ARCHITECTURAL  
DIMENSIONS

March 30, 2017

City of Oakland  
Planning Department  
Oakland, CA 94612

■ 300 Frank H. Ogawa Plaza, Suite 375  
Oakland, CA 94612

■ [www.archdim.com](http://www.archdim.com)

■ James M. Heilbronner  
Architect C11531

Re: Club Knoll Building  
Oak Knoll Project  
Oakland, CA

City of Oakland:

I write in response to questions regarding the need for a new steel frame structure within the rehabilitated Club Knoll Building. I am a licensed architect with 40 years of experience. I have rehabilitated numerous historic buildings and hundreds of less significant buildings. I am well versed in the California Building Code, State Historic Building Code, as well as the Secretary of the Interior's Standards for Rehabilitation.

There is a general misunderstanding of the magnitude of rehabilitating old buildings due to issues that are not merely aesthetic. Old buildings suffer from years of use, worn out systems, non-conformance with contemporary codes and today's standards of living. Whether the building is moved or not, the structure of the building will have to be addressed due to the size of rehabilitation spending and its interface with a complete new foundation system.

Club Knoll's existing wood frame will not sustain code defined environmental loads, such as wind loads and seismic loads, making it unsafe, even in its current location. Further, even if the structural system was adequate to sustain environmental loads, moving the building will require the disassembling and/or disconnecting structural components, particularly exterior walls that are the primary structure that withstands vertical and lateral loads.

Wood structures relies on the continuity of the framing so once cut into movable components the components, by themselves, are not easily stitched back together to form a congruent structure. Simply reconnecting the components will not be adequate to sustain current code forces. The proposed new steel skeleton will be the structural system to withstand the environmental loads and, at the same time, work to stitch the building components together including exterior walls and roof components, therefore not requiring alteration to the components. The building components, original to the building, will form around the new skeleton to preserve historic aesthetics and geometry of the components and building while working to transfer environmental loads to the steel frame that will meet current code standards.

Absent a new structural system, the building would lack sufficient structural integrity to be safe for human occupancy. This steel frame will not be visible after completion of the project nor could it ever be removed unless Club Knoll is demolished or again relocated.

Sincerely,

ARCHITECTURAL DIMENSIONS

  
James M. Heilbronner, President

This page is intentionally blank.



**Appendix I**  
Evaluation of the Proposed  
Club Knoll FDP for Compliance  
with the Secretary of Interior's  
Standards



# CLUB KNOLL RELOCATION AND REHABILITATION EVALUATION

---

## Evaluation of the Club Knoll Final Development Plan for Compliance with the Secretary of Interior Standards for Rehabilitation

### 1. Introduction

Club Knoll is a potential historic resource as defined by Section 15064.5 of the CEQA Guidelines and Policy 3.8 of the Historic Preservation Element (HPE) of the General Plan. Club Knoll is a locally-designated historic resource.

The proposed Oak Knoll Mixed Use Community Project (project) proposes to relocate sections of Club Knoll to a central portion of the site, rehabilitate the relocated sections of the structure, and reuse the building as a community center and for accessory uses. The City of Oakland released a Notice of Availability (NOA) of the Draft Supplemental Environmental Impact Report (SEIR) prepared for the project for public review and comment on August 26, 2016. The analysis in the Draft SEIR considered the project sponsor's 2016 draft *Club Knoll Relocation and Rehabilitation* plan ("2016 draft plan") (Architectural Dimensions, 2016) and its evaluation prepared by Carey & Co. (Carey, 2016) on behalf of the project sponsor. The project sponsor subsequently prepared the *Club Knoll Relocation and Rehabilitation Final Development Plan* ("Club Knoll FDP") evaluated in this document.

The Draft SEIR identified several mitigation measures to protect Club Knoll before, during, and after relocation. New Mitigation Measure CUL-1.5 specifically requires the project sponsor to prepare a final Club Knoll relocation work plan to ensure that the proposed relocation would comply with the *Secretary of the Interior's Standards for Rehabilitation and Guidelines for Rehabilitating Historic Buildings*. The project sponsor must comply with these mitigation measures before obtaining building permits.

This evaluation considers whether the proposed Club Knoll relocation and rehabilitation conducted pursuant to the Club Knoll FDP and mitigation measures in the Draft SEIR can be implemented in a manner that meets the Secretary of Interior's Standards for Rehabilitation.

## 2. Evaluation of the Draft Club Knoll FDP in Accordance with the Secretary of the Interior's Standards for Rehabilitation

As Club Knoll is an historic resource, the proposed project incorporates the Rehabilitation Treatment as the selected treatment for relocation or alteration of the structure. The Department of the Interior defines rehabilitation as “the process of returning a building or buildings to a state of utility, through repair or alteration, which makes possible an efficient use while preserving those portions and features of the building and its site and environment which are significant to its historic, architectural, and cultural values.” (U.S. Department of Interior regulations, 36 CFR 67) The corresponding Standards for Rehabilitation allow for some modification to the building, provided various elements of the building's historical significance are retained.

The Secretary of the Interior's Standards for Rehabilitation identify ten standards for determining the appropriateness of a proposed project with regards to the preservation of the historic materials and features (U.S. Department of Interior regulations, 36 CFR 67). The proposed project is analyzed below in accordance with each standard. Compliance with each of the ten standards is not required for an overall determination that the project is compliant with the Secretary of the Interior's Standards for Rehabilitation.

### Rehabilitation Standards

**1. *A property will be used as it was historically or be given a new use that requires minimal change to its distinctive materials, features, spaces, and spatial relationships.***

The Club Knoll building was originally constructed as a clubhouse to service the private golf course that once existed on the Oak Knoll project site. In that capacity, Club Knoll contained numerous large, open and semi-public spaces, as well as smaller, private areas for club members. During the Navy's period of occupation at the project site, the building served a number of purposes, including temporary lodging, recreational and public gatherings, and food service. The proposed Oak Knoll project highlights Club Knoll for reuse as a community center and office for the Home Owners Association (HOA), with occasional public access through facility rental opportunities.

The proposed project will accommodate semi-public uses, community gatherings, and office activities similar to those that previously existed at Club Knoll. Additionally, these uses will be distributed throughout the modified building in a way that echoes the historic distribution of uses within the various spaces. The proposed project will also retain the historical circulation patterns through the building, with access at grade on multiple levels as a response to the sloping site. The location of the building's primary points of ingress and egress will also be maintained. The proposed uses allow for the original spaces, materials, and circulation patterns to be maintained. This limits potential impacts on the building's interior. For example, the openness of the common areas at the front of the building will be maintained, while more private uses will be toward the wings, a configuration that existed historically. As a result, the proposed project is compliant with Rehabilitation Standard 1.

**2. The historic character of a property will be retained and preserved. The removal of distinctive materials or alteration of features, spaces, and spatial relationships that characterize a property will be avoided.**

The primary criterion for recognizing Club Knoll as a historic resource is its architectural design. (Carey, 2016; 2) The structure is an excellent example of Spanish Colonial Revival architecture, an architectural style that was popular during the 1920s when the Oak Knoll Golf Course and Country Club was developed. However, historic character goes beyond architectural style or the individual elements that comprise the design, and includes the overall setting and composition of the building as well.

Currently the building sits in a lightly wooded area on a site with a sloping grade. It is built into the hillside, creating an asymmetrical design with entrances at grade on the first floor in the rear, and at grade at the basement level in the front. The main entrance is accessed from an exterior stair built in the same style as the rest of the structure. The vertical massing of the building is further heightened by the double-height tower set off center in the front façade. The horizontal massing is dominated by the front portico and accented by the “third wing” that extends to the north side of the entrance.

On the interior, a relatively ornate lobby with mezzanine provides an entry point for the public. From there, access to the largest rooms in the building is provided. These two public rooms, to the left and right of the front entrance respectively, are also ornamented with a number of distinctive features, including fireplaces, carved wood elements, exposed ceiling trusses, cathedral ceilings, and wood floors. Moving straight through the lobby, there is access to the third main public space, the outdoor, enclosed courtyard. All other remaining interior spaces were historically private areas for members, offices, or housed support functions.

In the proposed project, substantial portions of the building will be relocated to a new site. The basement and the third wing will be demolished. Previous studies have evaluated the architectural significance of the basement and third wing and concluded that they are not individually historically significant nor does the loss of these features diminish the overall design of the building to a significant extent. (Carey, 2016; 23-24, 29-30).

The relocation site has a grade that resembles the existing building location, thus allowing the structure’s asymmetrical design to be reconstructed. The new basement is designed to be similar to the existing basement. The existing building’s at-grade access to the front elevation of the basement, at-grade access to the rear courtyard, and an exterior stair to provide access through the original front door, will be recreated as part of the proposed design of the new basement level.

Interior, non-historic walls will be removed to return the original public spaces of the building to a more accurate historic arrangement. The project will relocate and rehabilitate the main hall, dining hall, lobby, mezzanine, building wings, maintaining a courtyard and the tower, each of which is a distinctive feature and/or space of the building that, together,

establish spatial relationships that will also be maintained. Public access to the two large front rooms and the rear courtyard will be maintained. When moved, Club Knoll will be oriented so that its setting and access points remain historically accurate. As in its current location, the courtyard will face the parking area, and the opposite side will face open landscaped areas. The proposed landscape plan locates trees and landscaping planted around the building. Further, original decorative features will be protected in place or removed and reinstalled after the building has been relocated.

As proposed, the project will retain the historic character of the property. This includes many individual details as well as overall massing, setting, circulation, and materials. As such, the proposed project is compliant with Rehabilitation Standard 2.

**3. *Each property will be recognized as a physical record of its time, place, and use. Changes that create a false sense of historical development, such as adding conjectural features or elements from other historic properties, will not be undertaken.***

This project proposes to remove one wing of offices (“third wing”) from the original structure. This changes the structure’s overall massing and some elements of circulation within the interior spaces. The original basement level will also be removed, but then replaced with new construction. After relocation, the building will be repaired with materials that match the existing, (i.e. stucco with stucco), or recreated with materials that mimic the original (i.e. original lath and plaster with sheetrock) to maintain the historic design and appearance of Club Knoll. The intent is to match all new construction with those elements that date to the original period of construction. While this will create a modified building that appears to date to 1927, it will in fact be a mixture of 1927 and modern materials, designs, and construction methodologies. The Club Knoll FDP includes measures to prevent the potential for the proposed design to “create a false sense of historical development.” (See further discussion under Rehabilitation Standard 9 regarding the differentiation of new construction from original construction.)

The proposed project will retain the overall massing and circulation of the building, largely through the replacement of the existing basement level with a new basement level that will be distinguishable from the original upper levels through slight variations in materials and/or finishes. No conjectural features will be added as part of the rehabilitation. Therefore, the proposed project is compliant with Rehabilitation Standard 3.

**4. *Changes to a property that have acquired historic significance in their own right will be retained and preserved.***

The proposed project will demolish the “third wing” of the building and remove and replace the basement level. The third wing historically served to house support function such as offices, while the basement contained locker rooms and utility spaces. The interior spaces and finishes are a mix of original and non-original elements. None have been noted in previous evaluations as significant in their own right.

While the areas identified for demolition date to within the period of significance the original finishes have been lost (Carey, 2015; 5). It is these elements' overall massing and architectural design that is most important. The third wing is set back from the front façade, forming a secondary façade that was historically masked by vegetation. Its removal would alter the overall composition of the design. The basement is an important feature to the extent it is exposed on the front elevation, which forms an integral part of the architectural design.

Relocation of the existing basement is not practicable because it is predominantly built into a hillside that is exposed only on one side. As discussed under Rehabilitation Standard 3, the proposed design to replace the basement includes new construction of similar proportions and with a similar relationship to the landscape, thus retaining the overall design. The project proposes to retain the front elevation.

Overall, the removal of these substantial sections of the original building will alter the historic massing and result in a loss of original materials. However, aforementioned previous studies have confirmed that, pertinent to Rehabilitation Standard 4, neither the third wing nor the basement represent changes to the original building that have acquired significance over time. Therefore, the proposed project is compliant with Rehabilitation Standard 4.

**5. *Distinctive materials, features, finishes, and construction techniques or examples of craftsmanship that characterize a property will be preserved.***

The 2016 Carey & Co. report (Carey, 2016; 25-26) identifies the following character-defining features of Club Knoll:

**Exterior**

- Irregular plan with varied massing
- Asymmetrical layout
- Mix of roof types – gable and shed
- Bell tower
- Chimneys – stucco clad and rock
- Varied openings – Wide range of window and door sizes and shapes, wood and metal windows and doors
- Juliet balconies – Metal railings adorn the small balconies
- Covered arcade around courtyard
- Exterior stair to main level
- Deck at second level
- Stucco cladding
- Red roof tiles
- Decorative stucco detailing – Quatrefoil vents, brackets, keystones, etc.
- Built into the side of a knoll
- Open landscape to the west of the building
- Enclosed courtyard with fireplace and fountain

**Interior**

- Wood trusses and exposed wood ceiling construction
- Decorative corbels

- Decorative plasterwork – An orchestra balcony and columns in lounge
- Wood panel doors
- Wood floors
- Simple wood columns and beams
- Simple wood baseboards
- Massive rock fireplaces
- Sequence of public spaces – Lobby flanked by two large rooms (lounge to the south and dining to the north)

The Club Knoll FDP calls for all of these elements to be salvaged, repaired, or recreated depending on their type, condition, and location. Retention of original elements is an important part of Rehabilitation Standard 5. Retention in place is most desirable, while removal and reinstallation after repairs are complete is acceptable. Methodologies for managing the protection, assessment, and treatment of the character-defining features are described in New Mitigation Measures CUL-1.1 – CUL-1.5 of the Draft SEIR. Specifically, New Mitigation Measure CUL-1.5 (i) specifies that the project shall ensure that character-defining features that are not deteriorated beyond repair, including historic windows and surviving window hardware, are preserved during dismantling, and properly installed and reassembled in their original location. Overall, compliance with, and proper implementation of these mitigation measures, as referenced on Club Knoll FDP, Sheets DR-2.1 and DR-2.2, make the proposed project compliant with Rehabilitation Standard 5.

**6. *Deteriorated historic features will be repaired rather than replaced. Where the severity of deterioration requires replacement of a distinctive feature, the new feature will match the old in design, color, texture, and, where possible, materials. Replacement of missing features will be substantiated by documentary and physical evidence.***

The proposed project calls for salvage, storage, repair, and reinstallation of historic decorative elements including: roof tiles, roof trusses, doors, windows, columns, corbels, emblems, wood trim (interior and exterior,) wood flooring, truss base moldings, railings, and hardware. New Mitigation Measures CUL-1.1 - CUL-1.5 in the Draft SEIR all concern the evaluation of materials before, during, and after the relocation to guard against unnecessary damage. Following these measures will limit unforeseen damage to historic elements, thus allowing them to be repaired rather than replaced. In the event replacement is needed, for those limited instances, the project outlines that “care shall be taken to match any new materials with the original materials” (Club Knoll FDP, Sheet DR- 2.2). Compliance with New Mitigation Measures CUL-1.4(f) and CUL-1.5(g) in the Draft SEIR are two specific examples where elements must be replaced; the replacements should match the original in quality as well as material. As specified in the Club Knoll FDP, replacement elements shall be marked as such so as to distinguish them from the original, historic elements; a date stamp or craftsman’s mark on a non-exposed surface is recommended. It is understood from the Club Knoll FDP that some historic finishes, such as the lath and plaster walls, and portions of the wood floor are already damaged beyond repair because of prior neglect and vandalism. The final FDP proposes that these elements will be replaced in-kind according to the aforementioned mitigation measures and final FDP.

Provided the provisions of New Mitigation Measures CUL-1.1 – CUL-1.5 and all treatments in the Club Knoll FDP are implemented where necessary, the proposed project will be in compliance with Rehabilitation Standard 6.

**7. Chemical or physical treatments, if appropriate, will be undertaken using the gentlest means possible. Treatments that cause damage to historic materials will not be used.**

The proposed relocation of Club Knoll constitutes a physical treatment. The level of impact of this treatment is largely dependent upon the details of the relocation itself, as defined in Club Knoll FDP. As prescribed in New Mitigation Measures CUL-1.2 and CUL-1.5 in the Draft SEIR, much can be done by the project sponsor to minimize damage before, during, and after relocation when, even under ideal circumstances, damage may occur.

The proposed project calls for the building to be “braced and shored” to prepare the building for relocation. The exact nature of the bracing and shoring will be prepared according to the provisions of New Mitigation Measures CUL-1.2 and CUL-1.5. Bracing and shoring activities may require removal of interior plaster finishes and applied ornaments. As noted in the Club Knoll FDP, the interior finishes are currently quite damaged, and would require replacement even if the building were left in place (Club Knoll FDP; Sheet DR-2.1[B] and Sheet DR-2.2 [H]). The applied ornament is called out for salvage, repair, and reinstallation according to the provision of New Mitigation Measure CUL-1.4. As described, the “largest components of building possible will be moved intact to avoid full dismantlement of the building and a substantial adverse change” (Club Knoll FDP; Sheet DR-2.1). This means building segments, preferably entire rooms or wings, as opposed to individual walls or singular planer elements, may be relocated as whole units, however, the exact location of cuts and size of each segment has yet to be determined, as it is not possible to precisely define until the dismantlement process begins, as specified in the Club Knoll FDP; Sheet DR 2.1. This will require further study according to the provisions of New Mitigation Measure CUL-1.4 (Club Knoll FDP; Sheet DR-2.1).

The proposed project assumes that the relocated segments may no longer be structurally sound, and therefore the pre-construction of a steel frame is proposed so that the existing components of the building do not have the full burden of being structurally sound as a building unit (Club Knoll FDP; Sheet DR-2.2). The Club Knoll FDP describes that a new structural frame would be designed to fit within the existing components as much as practical, as to not damage historic materials (or be visible), pursuant to New Mitigation Measure CUL 1.5(e). Also, the Club Knoll FDP includes measures that ensure careful attention to the various materials (i.e. metal versus wood framing) to limit cracking as the building settles and as these materials react to changing environmental conditions.

The final FDP does not describe the specific methodology to attach the historic building segments to the pre-existing steel frame, and therefore the likelihood that historic materials would not be damaged. Therefore, full compliance with this Rehabilitation Standard would depend on the exact approach to the work, which will be specified in the work plan required by New Mitigation Measure CUL-1.5. To allow flexibility in determining the final structural



method applied to relocate and reassemble the building on the new site, the final FDP specifies that the California State Historical Building Code (SHBC) would be implemented to the greatest extent possible and permitted by the City of Oakland. Application of the SHBC could provide additional alternative methodologies to relocate and reassemble the building on the new site without the need for an entirely new structural system. However, use of the SHBC would only be considered to the extent that it ensures life safety, retains historic character, and limits impacts on the historic resource as a whole. The Club Knoll FDP does recognize that a new steel frame would avoid the need for the old building components to be upgraded to sustain current code forces - a process that could be more impactful than moving the components.

As presented, the proposed project is compliant with Rehabilitation Standard 7, assuming compliance with, and proper implementation of, the specific measures referenced in the Club Knoll FDP.

**8. *Archaeological resources will be protected and preserved in place. If such resources must be disturbed, mitigation measures will be undertaken.***

Previous studies have concluded that archeological resources are unlikely to exist at the current or proposed project sites. However, if such resources are encountered, compliance with Oakland Standard Conditions of Approval (SCA) CUL-1, SCA CUL-2, and SCA CUL-3 would ensure the proposed project is in compliance with Rehabilitation Standard 8.

**9. *New additions, exterior alterations, or related new construction will not destroy historic materials, features, and spatial relationships that characterize the property. The new work shall be differentiated from the old and will be compatible with the historic materials, features, size, scale and proportion, and massing to protect the integrity of the property and its environment.***

As previously described, the project proposes to replace the existing basement with one of similar size, layout, and design to the original. This approach works well to maintain the historic spatial relationships, size, scale, and proportion of the building. In accordance with the Club Knoll FDP and discussed for Standard 3, where new elements are introduced, they will vary from original elements. For example, new balustrades will be compatible in design but not match historic designs, and variations in stucco texture or color will be considered for areas of new construction to provide distinction between original and contemporary construction.

Also pursuant to the Club Knoll FDP and discussed for Standard 6, where elements must be replicated because the originals are missing or too badly damaged for reinstallation, a date stamp or other such mark will be applied in an inconspicuous location on the element to differentiate between original and new decorative elements. This mark would not need to be visible to the public but will be clear to any future workman who might need to remove the item from its location in the future.

As proposed, the project is compliant with Rehabilitation Standard 9.

**10. New additions and adjacent or related new construction will be undertaken in such a manner that, if removed in the future, the essential form and integrity of the historic property and its environment would be unimpaired.**

During relocation, the building will be “braced and shored to ensure structural stability of the building during dismantlement that will weaken the building as components are cut away for relocation. The bracing will be reversible, additive, and shall not destroy any salvageable historic parts of the building.” (Club Knoll FDP; Sheet DR-2.1)

Once at the new site, the building will be subject to new construction but no exterior additions. Some damaged elements will be replaced, including some structural elements. These replacement parts are not considered new construction under the provisions of Standard 10. The new construction includes interior modifications to alter the original room configurations in basement level. New interior walls, once constructed, could be removed without causing a high degree of damage to original materials. As presented, the new basement level will be constructed separately from the historic building. Just as the original basement can be separated from the upper levels and still retain the building’s essential form and integrity, so too could the new basement be separated from the historic upper levels. The two elements (basement and upper levels) would then be structurally connected through various means, much of the success of that separation depends on details regarding the introduction of the new steel frame as discussed above for Rehabilitation Standard 7. The details regarding implementation of new structural elements will be addressed in the work plan as required by Mitigation Measure CUL-1.5. As presented, the proposed project is largely compliant with Rehabilitation Standard 10.

### 3. Conclusion

Overall, the proposed project, as presented and described in the Club Knoll FDP, is compliant with the Secretary of Interior’s Standards for Rehabilitation, provided the work is conducted pursuant to the Club Knoll FDP, as amended by this evaluation, and New Mitigation Measures CUL-1.1 through CUL-1.5 identified in the Oak Knoll Mixed Use Community Project SEIR. The Club Knoll FDP demonstrates that relocation of the Club Knoll building is feasible and that rehabilitation of the building will be done in a manner that meets the Secretary of Interior Standards for Rehabilitation.

If the City approves the project, it would require implementation of the mitigation measures in the SEIR as conditions of approval. Nothing in the Club Knoll FDP precludes the project sponsor's ability to comply with the mitigation measures. In fact, many features of the Club Knoll FDP already show consistency with New Mitigation Measure CUL-1.5. These include the following specific measures:

**CUL-1.5a.** Ensure that all temporary work to shore and brace the building will be reversible, additive, and shall not destroy any surviving historic fabric in the building.

- CUL-1.5b.** Ensure that a preservation architect and a structural engineer, as defined in the Carey & Co. report dated May 3, 2016, will be on site to monitor dismantlement and reassembly of Club Knoll.
- CUL-1.5d.** Ensure components and parts of the building dismantled during the relocation process are catalogued, protected, stored in a secure area, if necessary, and reassembled in their original location on the relocated building.
- CUL-1.5e.** Ensure that the proposed steel frame and new interior systems will not be visible in the relocated building, except as necessary for life safety or in newly installed kitchen, bathrooms, elevators, or similar systems.
- CUL-1.5f.** Ensure that protective barriers or buffers are provided to further protect the building from potential damage by construction activities from new construction around the relocated building, including the operation of construction equipment.
- CUL-1.5g (partial).** Ensure that if original wood floor material is found beneath more recent finishes, it shall be inspected for soundness and as much as possible shall be retained.
- CUL-1.5h.** Ensure all work, including improvements in compliance with the American Disabilities Act (ADA), will adhere to the *Secretary of the Interior's Standards for the Treatment of Historic Properties*, using the Rehabilitation Standards.
- CUL-1.5j.** Ensure the foundation is constructed such that the building, at the exterior stair location on the west elevation, is raised above to the surrounding finished grade.

The City would require evidence of compliance with each measure in Mitigation Measure CUL-1.5, including preparation of the "relocation work plan," when the project applicant seeks building permits and, for construction measures, during construction. Implementation of these mitigation measures further supports the Draft SEIR conclusion that the project would be consistent with the Secretary of the Interior's Standards.<sup>1</sup>

## 4. References

Architectural Dimensions, *Oak Knoll Relocation and Rehabilitation – Club Knoll*, (also referred to as FDP#1 and “2016 draft plan”), April 18, 2016.

Architectural Dimensions, *Final Development Plan: Club Knoll Relocation and Rehabilitation* (also referred to as FDP#2 and “Club Knoll FDP), April 3, 2017. (**Appendix G** to the Final SEIR)

Carey & Co., *Oak Knoll Golf and Country Club Building 18 at the Former Naval Medical Center Oakland, California, Relocation Evaluation*, May 3, 2016. (Part of **Appendix T** to the Draft SEIR)

---

<sup>1</sup> The Club Knoll FDP includes a Proposed Travel Route, which complies with measure “a” of Mitigation Measure CUL-1.4 (Relocation Travel Route).

## 5. Preparers

ESA  
350 Frank H. Ogawa Plaza, Suite 300  
Oakland, Ca 94612  
510.839.5066

- Becky Urbano, Senior Architectural Historian
- Dana McGowan, Cultural Resources Practice Leader
- Crescentia Brown, Community Development Director, Project Director, Oak Knoll SEIR

**Appendix J**  
EBMUD Water Supply  
Verification Applicability  
(2017)



March 14, 2017

Heather Kline, Planner IV  
City of Oakland, Bureau of Planning  
250 Frank H. Ogawa Plaza, Suite 2214  
Oakland, CA 94612

Re: Water Supply Verification Request – Oak Knoll Mixed-Use Community Plan Project,  
Oakland

Dear Ms. Kline:

This letter is in response to a request from Cox, Castle & Nicholson LLP (CCN), dated February 2, 2017 (copy attached), to prepare a Water Supply Verification (WSV) for the Oak Knoll Community Project (Project) located in the City of Oakland (City). Following receipt of CCN's WSV request, we discussed the Project, and you explained that the City considers the Project to be exempt from the Government Code's WSV requirements. East Bay Municipal Utility District (EBMUD) concurs with the City's conclusion.

Government Code section 66473.7(i) provides that WSVs shall not be required for "any residential project proposed for a site that is within an urbanized area and has been previously developed for urban uses, or where the immediate contiguous properties surrounding the residential project site are, or previously have been, developed for urban uses, or housing projects that are exclusively for very low and low-income households." As explained below, the Project is exempt from WSV requirements pursuant to section 66473.7(i).

The Project site, which is located within Oakland city limits, is within an urbanized area. *See* Public Resources Code section 21071 (defining "urbanized area" as, among other things, "an incorporated city that . . . has a population of at least 100,000 persons). Prior to decommissioning, the Project site was also home to a variety of urban uses, including housing, a credit union, post office, hospital, office space, and several recreational facilities. *See* Final Environmental Impact Statement/Environmental Impact Report for the Disposal and Reuse of Naval Medical Center Oakland (1998 EIR) on page 3-3. In addition, the Project site is surrounded on all sides by urban uses, including residential and condominium developments and small local commercial centers located within areas designated in the Oakland General Plan for relatively dense residential and commercial development. *See, e.g.*, Oak Knoll Mixed-Use Community Plan Project Draft Supplemental EIR (Project EIR), Figure 3-5 (showing major roads and urban development surrounding the Project site) on page 3-11 (describing current uses immediately surrounding the Project site); 1998 EIR, page 3-4 (describing uses immediately surrounding the Project site at the time of 1998 EIR preparation); and Oakland General Plan

Heather Kline, Planner IV

March 14, 2017

Page 2

Land Use and Transportation Element, pages 146-149 (describing general plan designations applicable to properties surrounding the Project site). As such, the Project site is also surrounded by immediate contiguous properties developed for urban uses. For these reasons, EBMUD concurs with the City's conclusion that the Project is exempted from the Government Code's WSV requirements pursuant to section 66473.7(i).

While EBMUD agrees that no WSV is required for the Project, we also note the adequacy of EBMUD's water supplies for the Project, as explained in detail in the Project's 2006 water supply assessment (WSA) and reiterated in our 2015 letters confirming the accuracy of the 2006 WSA. Nothing has changed with respect to that conclusion. Due to its location within EBMUD's ultimate service boundary (USB), the Project's water demand has been accounted for in EBMUD's water supply planning efforts, including its Urban Water Management Plan 2015. For existing and projected development within the USB, including the Project, EBMUD has, and will have, adequate water supplies during normal and wet years but may require significant customer water use reductions and may also need to acquire supplemental supplies to meet customer demand during multi-year droughts. During times of drought, this Project would be subject to the same restrictions and requirements as other EBMUD customers.

EBMUD appreciates the opportunity to provide this response. If you have any questions concerning this response, please contact me at (510) 287-1365.

Sincerely,



David J. Rehnstrom  
Manager of Water Distribution Planning

DJR:dks  
sb17\_056

Attachment: Letter to EBMUD from Cox, Castle & Nicholson LLP dated February 2, 2017

cc: Linda Klein  
Cox, Castle & Nicholson LLP  
50 California Street, Suite 3200  
San Francisco, CA 94111

# **Appendix K**

## ESA Technical Team Qualification







# Chris Rogers

## Biological Resources

### EDUCATION

B.S., Biology, emphasis in Botany, San Francisco State University

Graduate Studies, Ecology and Systematics, San Francisco State University

### 27 YEARS EXPERIENCE

### CERTIFICATIONS/REGISTRATION

California Endangered, Threatened and Rare Plant Collecting Permit #09026

### TRAINING

Arid West Wetland Delineation Workshop, USACOE, 2007

Property Analysis Record, Center for Natural Lands Management, 2004

Hydrology of Constructed Wetlands, Wetland Training Institute, 2001

California Wetlands, CLE International, 2000, 2007, 2015

Federal Endangered Species Act, CLE International, 1995

Wetlands Delineation Certification Training, 1995

Wetland Impacts and Mitigation, U.C. Davis Extension, 1992

Wetlands Delineation Training, 1991

Chris serves in both managerial and technical roles in ESA's Bay Area Biological Resources and Land Management Group, which includes 15 natural resource professionals. He specializes in complex permitting, regulatory compliance, wetland ecology and restoration, environmental impact assessment, and endangered species habitat restoration planning. Specific areas of expertise include management of large-scale and fast-track biological resource analyses and jurisdictional wetland delineations in support of multi-agency permits, construction compliance monitoring and reporting, preparation of accurate and defensible environmental documentation, habitat assessments and mapping and analysis, endangered species evaluations, restoration and mitigation planning, peer review, and public meeting presentations. Chris frequently acts as a technical liaison between project design and engineering clients and ESA's environmental planning and permitting specialists.

### Relevant Experience

**U.S. Department of Veterans Affairs, Palo Alto Health Care System, Biological Resource Survey.** *Lead Biologist and Project Director.* Chris is overseeing surveys and GIS mapping of biological resources at the three campuses in the Palo Alto Health Care System, located in Palo Alto, Menlo Park and Livermore. This work will support the VA in its future development, operations, and maintenance of these facilities by providing a baseline of biological conditions and GIS data layers that can be used in preparation of environmental planning documents. In addition ESA is providing a robust suite of recommendations that can be adapted as mitigation measures for addressing potential impacts to biological resources, including special status species and wetlands.

**Kaiser Permanente Oakland Medical Center, Glen Echo Creek Restoration Project, Oakland, CA.** *Lead Biologist and Project Manager.* Chris assisted with design, implementation, and long-term monitoring of an urban creek restoration project implemented by Kaiser Permanente as mitigation for temporary impacts from construction of the West Broadway Medical Services Building (MSB) and Cancer Center. Chris provided design recommendations to adapt to unanticipated field conditions, quality control of restoration plant materials, devised the monitoring program to meet regulatory agency requirements, and supervises field staff to carry out the monitoring program and complete annual reports on successful performance of the site.

**California Department of Water Resources (DWR) South Bay Aqueduct Improvement and Enlargement Project EIR, Alameda County, CA.** *Biologist and Wetland Permit Specialist.* Chris assessed wetland and sensitive species habitat along 44-mile South Bay Aqueduct, and obtained multiple permits. Chris was integrally involved in review of preliminary engineering designs to identify environmental constraints, working with DWR design engineers to refine final plans and specifications to avoid or minimize environmental issues, in particular

to reduce regulatory requirements. He coordinated permit applications and negotiated permit conditions with ACOE (Sacramento and San Francisco Districts), USFWS, CDFG, and the San Francisco Bay RWQCB. Chris assisted to identify suitable and available land for mitigation and developed conservation easement strategies, and continues to supervise the maintenance and monitoring of the conservation lands.

**Contra Costa Water District, Los Vaqueros Reservoir Expansion Project EIS/EIR, Contra Costa County, CA.** *Biologist.*

Chris participated on the field biology team that performed wetland and botanical studies of pipeline, facilities and reservoir expansion alternatives. He coordinated survey timing requirements to maximize coverage of miles of study corridor over dozens of individual private parcels. He is oversaw field data management and preparation of a comprehensive wetland delineation and rare plant technical report, contributed to the basis of design for wetland mitigation, and conducted pre-construction clearance surveys for rare plants. Chris also conducted surveys of several properties under consideration as off-site mitigation land acquisitions.

**SFPUC San Francisco Groundwater Supply Project, San Francisco, CA.**

*Biologist.* ESA is providing this specialized natural resource, environmental, and environmental planning expertise to assist the SFPUC to evaluate several groundwater management alternatives. Chris developed the ecological basis for a GIS-based numerical and spatial analysis of the effects of raising or lowering water levels on wetlands, rare plants and wildlife habitats on the shore of Lake Merced. In collaboration with ESA's GIS technical staff, Chris evaluated several existing models, identified the parameters that most efficiently captured the effects of changed conditions, and analyzed the results in the context of the SFPUC's 50-year hydrological model output. He assisted in summarizing the results for the EIR.

**California Public Utilities Commission CalAm Monterey Peninsula Water Supply Project, Monterey County, CA.** *Biologist.*

Chris prepared the biological resources section of the CEQA document for the California America Water Company's (CalAm) Monterey Peninsula Water Supply Project. She also conducted presence/absence surveys for special status plant species within the project boundary. The proposed project is a desalination project to provide water supply to CalAm's Monterey service area.

**Beringer-Blass Wine Estates EIR, Napa, CA.** *Botanist and Wetland Ecologist.*

Chris prepared biological and wetland permitting documentation for submittal to the U.S. Army Corps of Engineers (Corps), USFWS, and California Department of Fish and Game (CDFG) for impacts to listed species and wetlands for biological surveys of the 218-acre project site. He performed rare plant surveys and a wetland delineation, and with ESA's geologist, conducted a subsurface soil investigation to determine the optimal location and size of created vernal pools, which was summarized in an Ecosystem Restoration Plan and Long Term Management Plan. The 218-acre project site is south of the Napa County Airport and west of State Route 29. The proposed project included 1.4 million square feet of new structures, 120 acres of vineyards, protected wetland and riparian areas, and wastewater treatment and storage ponds. Although the project ultimately was canceled, it was the largest structure ever to be proposed in Napa County, and one that would be situated within the highly controversial and legally challenged Airport Industrial Park Specific Plan area.



# Rachel Danielson

## Biologist

### EDUCATION

B.S., Public Affairs,  
Indiana University

### 9 YEARS EXPERIENCE

#### Specialized Training

Golden Gate Audubon  
and California  
Academy of Sciences,  
Master Birder Training  
Course, Feb.-Dec.  
2014

San Francisco State,  
Basic Wetland  
Delineation Training,  
2014

Focused Classes on  
Birding in the Bay  
Area, 2010, 2011,  
2012, 2014

Transportation Worker  
Identification  
Credential (TWIC),  
2009

UC Berkeley  
Extension CEQA  
Training, 2008

Laguna de Santa  
Rosa Foundation,  
Rare Pond Species  
Survey Techniques  
Workshop, 2008

### PROFESSIONAL AFFILIATIONS

The Wildlife Society,  
San Francisco Bay  
Area Chapter  
Treasurer,  
2013 - 2015

Rachel offers knowledge of Bay Area ecology, environmental planning, and environmental regulations, through nine years of environmental consulting work. She has project experience in conducting nesting bird surveys, special status species surveys (California red-legged frog, California tiger salamander, San Joaquin kit fox, burrowing owl, Ridgway's rail, San Francisco dusky-footed woodrat, and salt marsh harvest mice), construction compliance monitoring and SWPPP inspection, botanical surveys, wetland delineations, writing habitat assessments and CEQA analysis of project-related impacts on biological resources, and tracking and managing environmental data in support mitigation and monitoring plans. Rachel develops and implements project-specific environmental training programs and manages compliance monitoring and reporting documentation for a variety of projects. Prior to joining ESA, Rachel served as an Environmental Multi-media and Research Contractor for federal agencies, and assisted in forest inventories, avian surveys, and invasive vegetation monitoring for non-profit groups in the Central Valley and Sierra foothills.

### Relevant Experience

#### **SWCA Environmental Consultants, Pier 70 Environmental Impact Report, San Francisco, CA. *Biologist.***

Rachel performed reconnaissance surveys of the project area and authored the terrestrial biological resources impact analysis for the EIR. ESA served as a subconsultant to Turnstone Consulting for certain technical sections of the document including Air Quality, Biological Resources, Wind/Shadow, Sea Level Rise, and Cultural Resources. The proposed project would include demolition eight existing buildings, and construction of replacement and new housing, office, and retail uses, new infrastructure, open space and community amenities on a 28-acre site located in the southeast corner of the approximately 66-acre Port-owned area known as Pier 70, as well as an adjacent 7-acre area fronting Illinois Street between 20th and 22nd Streets.

#### **SFPUC, Vista Grande Drainage Basin Improvement Project Environmental Impact Statement / Environmental Impact Report, Daly City, CA. *Biologist.***

The project purpose is to address storm-related flooding in the Vista Grande Drainage Basin and manage Lake Merced water levels (maintained by the SFPUC) in part by replacing the Daly City outfall structure, located on the beach below Fort Funston. The project would alleviate flooding and improve the ocean outfall while reconnecting a significant portion of the lake's historic watershed. Rachel authored the biological resources impact analysis and performed protocol surveys for nesting peregrine falcons and nesting bank swallows in the vicinity of the Vista Grande project location at and around Fort Funston.

**City of San Francisco Environmental Planning, Golden State Warriors Arena LLC, Event Center and Mixed-Use Development at Mission Bay Blocks 29-32 Supplemental Environmental Impact Report, San Francisco, CA. *Biologist.*** Rachel performed reconnaissance surveys of the project area and authored the biological resources impact analysis for the

project environmental document. The project consists of an ambitious proposal by the Golden State Warriors (GSW) to construct a world-class arena/event center at Mission Bay Blocks 29-32 in San Francisco that would serve as the new home for GSW headquarters and basketball games, as well as a year-round venue for concerts, cultural events, conventions and other uses such as a hotel and residential housing.

**Presidio Trust, New Presidio Parklands Project Environmental Assessment, San Francisco, CA. *Biologist.*** ESA prepared the Environmental Assessment for cultural, biological, and visual resources to support Presidio Trust NEPA compliance for the New Presidio Parklands Project. Rachel performed a reconnaissance survey of the project site and authored the biological resources section of the Environmental Assessment.

**SFPUC, Pacific Rod and Gun Club Upland Soil Remediation Project Compliance Monitoring, San Francisco, CA. *Environmental Compliance Manager/Project Manager.*** Rachel managed the environmental compliance staff team conducting preconstruction surveys and monitoring onsite biological resources during soil remediation of the Pacific Rod and Gun Club, located on the southwest shore of South Lake Merced. Primary concerns for project implementation include potential impacts to special-status plants, special-status bats, nesting birds, and wetlands along the north shoreline. Rachel conducted preconstruction nesting bird, special-status plant, and tree canopy density surveys, and is the primary contact for project compliance concerns, regularly communicating with the client project managers. She reviewed environmental compliance reporting documentation and restoration-related RFIs and submittals and performed project invoicing, progress reporting, and budget management. Rachel previously authored the biological resources impact analysis for the project IS/MND lead by ESA.

**Placeworks, Pigeon Point Lighthouse General Plan CEQA and Technical Studies, Pescadero, CA. *Biologist.*** ESA supported Placeworks' preparation of the Pigeon Point Lighthouse General Plan and IS/MND through preparation of technical studies and CEQA sections for biological and cultural resources, traffic, and sea level rise. The General Plan would address a number of upgrades and improvements to facilities, new/improved trails, potentially opening the lighthouse for visitors, and possibly camping. Rachel conducted a reconnaissance survey of the plan area and prepared the Biological Resources analysis for the General Plan IS/MND.

**SFPUC Westside Recycled Water Project Biological Assessment, San Francisco, CA. *Biologist.*** Rachel prepared the Biological Assessment for potential project-related impacts to California red-legged frog, a federal-listed threatened species, in support of the project permits. ESA prepared the EIR for the San Francisco Westside Recycled Water Project and is currently supporting NEPA and permitting efforts. The purpose is to reduce the City and County of San Francisco's reliance on potable water for nonpotable uses by meeting the current water demand of several SFPUC customers that have substantial irrigation needs, including Golden Gate Park, Lincoln Park golf course, and portions of the Presidio. Highly treated wastewater will be produced at a new recycled water treatment plant and distributed via pipeline network to a series of reservoirs and pump stations.

**Midpeninsula Regional Open Space District, Monte Bello Open Space Preserve Bridge Replacement Initial Study/Mitigated Negative Declaration, Palo Alto, CA. *Biologist.*** Rachel performed reconnaissance surveys of the project area and authored the biological resources impact analysis for the project Initial Study/Mitigated Negative Declaration. The



project includes the removal and replacement an existing pedestrian bridge and the installation of an additional pedestrian bridge over Stevens Creek and Tributary Creek waterways within the District's trail system. Wildlife species concerns included nesting birds, roosting bats, San Francisco dusky-footed woodrat, San Francisco gartersnake, California red-legged frog, foothill yellow-legged frog, and red-bellied newt.

**SFPUC, Little Yosemite Fish Passage Project Initial Study/Mitigated Negative Declaration, Sunol Regional Wilderness, CA. *Biologist.*** ESA conducted the CEQA compliance and permitting processes in support of SFPUC's proposed Alameda Creek fish passage improvements. The proposed project involves creek bed modifications through the Little Yosemite reach of Alameda Creek to increase pool depths and reduce fall drops to facilitate steelhead migration. ESA has also conducted several technical studies to support the CEQA and permitting effort, including preparation of a wetland delineation, cultural resources surveys, and protocol-level surveys for special-status plants with potential to occur on the project site. Rachel performed a reconnaissance survey of the project area and authored the biological resources impact analysis for the CEQA document.

**City of Oakland, 12<sup>th</sup> Street Wetland Mitigation Monitoring, Oakland, CA. *Biologist.*** ESA is providing technical monitoring and reporting of the mitigation planting site for five years which includes quantitative wetland vegetation monitoring, upland vegetation monitoring, and hydrologic monitoring associated with the Lake Merritt 12<sup>th</sup> Street Reconstruction and 10<sup>th</sup> Street Channel Improvement Project. Rachel performs wetland vegetation monitoring once annually, upland vegetation monitoring on a monthly basis, hydrologic monitoring six times annually and prepares the annual reports to the permitting agencies. ESA PWA designed the tidal marsh mitigation site for the project.

**University of California San Francisco (UCSF), Long Range Development Plan EIR, San Francisco, CA. *Biologist.*** ESA is prepared the EIR for the 2014 Long Range Development Plan (LRDP) and Rachel authored the impact analysis on biological resources. The LRDP will guide campus growth and development of the University through the year 2035. UCSF is projecting to grow by approximately 2.4 million square feet over this time period, accommodating an additional 900 students and 11,000 employees.

**Kiewit Infrastructure West Co., San Francisco-Oakland Bay Bridge Marine Foundation Demolition, Oakland, CA. *Biologist.*** Rachel acted as an environmental monitor of the Pier E3 demolition, providing support to the Kiewit/Manson Joint Venture Team in moving the San Francisco-Oakland Bay Bridge East Span removal project forward. Pier E3 was the first and largest pier to be removed and formerly supported the east end of the cantilever section of the original Bay Bridge. Rachel's responsibilities included monitoring for nesting birds, general water quality conditions, marine mammals, hazing birds, and documenting observations in daily reports.



# Chris Sanchez

---

## Air Quality/GHG Emissions; Noise

### EDUCATION

B.S., Environmental Science, University of California, Berkeley

U.C. Berkeley Extension; Toxic Air Contaminants

### 23 YEARS EXPERIENCE

Chris Sanchez has more than 23 years of experience managing, conducting and monitoring air quality, greenhouse gas, noise and energy investigations and surveys for urban development, transportation, and infrastructure projects. He has prepared greenhouse gas emission inventories for five years since the passing of Assembly Bill 32. His professional training and experience have augmented an academic background in air quality, physics, chemistry, meteorology, and energy. Chris has a bachelor's degree from U.C. Berkeley in Environmental Science with additional studies from U.C.B. in toxic air contaminants. He is trained and proficient in the CalEEMod air quality emissions model as well as in air dispersion modeling using the AERMOD dispersion model. He is proficient in use of the traffic noise model of the Federal Highway Administration (FHWA) and the Roadway Construction Noise Model. He has been involved in dozens of major projects including major commercial airport master plans, divestiture of the State of California's power plants, mining projects and reclamation plans, rail transit extension projects and arena construction projects.

### Relevant Experience

**Oak Knoll Mixed Use Community Plan Project Supplemental Environmental Impact Report.** *Senior Air Quality and Noise Analyst.* ESA is currently preparing an Environmental Impact Report for a proposed mixed use development of residential neighborhoods, commercial development, and open space and recreational facilities on approximately 165 acres of the former decommissioned Naval Medical Center Oakland property at Oak Knoll. The proposed development would locate residential land uses within close proximity of Interstate 580. Chris performed an analysis of potential noise impacts to sensitive land uses and identified mitigation measures to address noise exposure impacts. Assessment of air quality impacts included health risks to existing and proposed sensitive receptors from a proposed multi-phased construction schedule as well as addressing significant and unavoidable impacts in light of the recent California Supreme Court decision in *Sierra Club v. County of Fresno* (Friant Ranch).

**Kaiser Center Office Project Environmental Impact Report, Oakland CA.** *Air Quality, Greenhouse Gas and Noise Analyst.* Chris prepared the criteria air pollutant analysis, noise analysis and greenhouse gas impact analysis for 1.5 million square feet of office and commercial uses in two new high-rise towers.

**Alta Bates Summit Medical Center, Summit Campus Seismic Upgrade and Master Plan Environmental Impact Report, Oakland, CA.** *Air Quality, Greenhouse Gas and Noise Analyst.* Chris prepared the criteria air pollutant analysis, noise analysis and greenhouse gas impact analysis for seismic improvements and construction of a state of the art medical center in Oakland California. Greenhouse Gas analysis included development of project-level and post mitigation emission inventories as well as a project-specific Greenhouse Gas Reduction Plan identified as mitigation.

**1500 Mission Street, San Francisco Air Quality and Noise Technical Studies.**

*Air Quality and Noise Analyst.* Chris prepared technical analyses for incorporation into an Initial Study for the proposed demolition of the two existing buildings on the project site and construction of two new towers—a 38-story, 380-foot-tall residential building (550 dwelling units) at the corner of Mission Street and South Van Ness Avenue, and an 18-story, 260-foot-tall office building on 11th Street between Market and Mission Streets. The 466,500-square-foot office building would be occupied by City of San Francisco offices, and would include a permit center for the Planning Department and Department of Building Inspection on the first two floors.

**University of California at San Francisco Long Range Development Plan Draft Environmental Impact Report.** *Air Quality, Greenhouse Gas and Noise Analyst.*

ESA prepared the environmental impact report for the 2014 Long Range Development Plan (LRDP) of UCSF. The LRDP will guide campus growth and development of the University over a 20+ planning horizon through the year 2035. UCSF is projecting to grow by approximately 2.4 million square feet over this time period, accommodating an additional 900 students and 11,000 employees. One key component of the LRDP is to address Senate Bill 1953, which mandates that all inpatient hospital facilities in the State of California meet more stringent seismic regulations by 2030. To meet this mandate, UCSF is proposing to build a new 308,000-square foot hospital addition at the Parnassus Heights campus site. In addition, the Mission Bay campus site is anticipated to grow substantially over the lifetime of the LRDP with multiple buildings proposed, including new research and office buildings as well as over 500 residential units. Chris prepared the assessment of air quality, greenhouse gas and noise impacts for each of the four campuses potentially affected by growth envisioned in the LRDP as well as cumulative regional contributions. This two-prong approach required of both project-level and overall plan-level criteria.

**City of Oakland, Broadway-West Grand Mixed-Use Project 2013**

**Environmental Impact Report Addendum.** *Air Quality, Greenhouse Gas and/*

*Noise Analyst.* CEQA documentation for the proposed modification to the Broadway – West Grand Mixed-Use Project, originally approved by the City Planning Commission in 2004 and evaluated in the 2004 environmental impact report. The 2013 Modified Project would reduce the number of residential units and associated open space, increase the commercial floor area, reduce the number of parking spaces, reduce the project heights, and retain and renovate several existing buildings, including historic resources, previously approved for demolition. The environmental impact report Addendum analyzed 2013 Modified Project's consistency with the effects of the original project and examined whether there are new, or more severe, significant effects. Updated analysis for Air Quality and Greenhouse Gases were included for informational purposes.

**Catellus Mixed-Use Development Subsequent Environmental Impact Report, Alameda, CA.** *Air Quality / Noise Analyst.*

Chris prepared the air quality and noise impact analysis for a Subsequent Environmental Impact Report (SEIR) that describes the environmental consequences of revising the previously-approved Catellus Mixed Use Development Master Plan (also referred to as the Alameda Landing Mixed Use Development) that was analyzed in the 2002 Catellus Mixed Use Development Environmental Impact Report and 2005 addendum to the environmental impact report. Key topics of in-depth analyses include impacts associated with traffic and circulation, traffic-related air quality and noise impacts, and biological resources impacts associated with in-water construction.



# Eryn Brennan, AICP

## Senior Managing Associate

### EDUCATION

Masters of Urban and Environmental Planning, University of Virginia

M.A., Architectural History, Certificate in Historic Preservation, University of Virginia,

B.A., History, University of California, Santa Cruz

### 10 YEARS EXPERIENCE

### PROFESSIONAL AFFILIATIONS

American Institute of Certified Planners

### AWARDS

Recipient of Dupont Fellowship and Peter Kutscha Memorial Scholarship, University of Virginia

Eryn is an urban planner and architectural historian with 10 years of experience assessing cultural resources and preparing and developing environmental assessments for a range of development projects. Her extensive project management experience, combined with her technical expertise in surveying and evaluating cultural resources, allows for seamless project facilitation through the environmental review process. Eryn has an in-depth knowledge and understanding of an array of cultural resources work, including field surveys, Historic American Building Survey (HABS) reports, conducting Section 106 reviews to identify, assess, and mitigate potential impacts to historic resources, urban design and visual resource analyses, design review for architectural review boards, and consultation with several state historic preservation offices. Eryn is a published author and former adjunct faculty member at the University of Virginia.

### Relevant Experience

#### **Strada Investment Group, 1629 Market Street, San Francisco, CA.**

*Project Manager.* The proposed project would demolish the three existing buildings and construct six new 55- to 85-foot-tall buildings containing 477 market-rate residential units, 107 affordable supportive housing units, 9,275 square feet of active ground-floor commercial uses, 27,296 square feet of space for the Local 38 Plumbers and Pipefitters Union, 264 below grade parking spaces and 22,395 square feet of publicly-accessible open space in accordance with the Market and Octavia Area Plan. The proposed project would preserve the exterior elements of the Civic Center Hotel and existing two-story retail building along Market Street. The project would be constructed in two phases with priority given to the construction of the new affordable housing units and the Plumbers Union Hall.

**Related California, 1500 Mission Street, San Francisco, CA.** *Project Manager.* The project consists of two components—development of a 39-story, 396-foot-tall mixed-use tower, and a 16-story, 240-foot-tall tower on 11th Street between Market and Mission Streets containing offices and a permit center to be occupied by several City and County of San Francisco departments. The project also would preserve a portion of the façades of the historic Coca-Cola building currently located on the site. Eryn is preparing the Initial Study and Focused Environmental Impact Report for the project and coordinating the technical analyses.

**AGI Avant Inc., 1270 Mission Street, San Francisco, CA.** *Deputy Project Manager.* The project consists of two options for a residential-over-retail tower: a Code-complying 120-foot, 13-story building with 195 dwelling units, and a 200-foot-tall variant that would develop a 21-story building with 299 units. Both the project and the variant would have approximately 2,000 square feet of ground-floor retail space, basement vehicle parking, and secure bicycle parking. Eryn prepared the Initial Study/Mitigated Negative Declaration for the proposed project and coordinated the technical analyses.



**City of Alameda Housing Authority, Del Monte Senior Housing Project, City of Alameda, CA. Project Manager/Lead Architectural Historian.** Eryn served as project manager of the Environmental Assessment (EA) prepared for the project. Because the project involves HUD funding, Eryn also prepared the Cultural Resources Study in conformance with Section 106 of the National Historic Preservation Act (NHPA) and coordinated tribal consultation. The cultural resource assessment included an evaluation of eight buildings located within the area of potential effect.

**Oryx Partners, LLC, 1001 Van Ness Avenue, San Francisco, CA. Project Manager.** The project consists of a 14-story mixed-use building containing approximately 256 dwelling units and 5,151 square feet of retail space along Van Ness Avenue. Eryn prepared the Initial Study/Mitigated Negative Declaration for the proposed project and coordinated the technical analyses.

**LeLand Properties, LLC, 2200 Stockton Boulevard, Sacramento, CA. Architectural Historian.** Eryn assisted in the field work and drafting of a Historic Resource Evaluation Report for the former Coca Cola Bottling Plant at 2200 Stockton Boulevard to identify the building's character-defining features and determine whether the proposed rehabilitation of the Plant would result in significant adverse impacts on the historic resource.

**California Crosspoint High School, Alameda, CA. Lead Architectural Historian.** In support of a project that proposed to relocate an existing private high school to a historic campus complex, Eryn conducted a reconnaissance architectural survey of the campus and coordinated with the City of Oakland to determine whether recent renovations had impacted the campuses eligibility for listing on the State and National Registers (S/NR).

**MidPen Housing, Brooklyn Basin Affordable Housing Project, Oakland, CA. Project Manager.** The project proposes to construct an affordable housing development with associated parking. Because HUD funding will be sought, an Environmental Assessment will be prepared for the project. Eryn will coordinate preparation of the Environmental Assessment and conduct the Section 106 analysis.

**428 Associate, LP, Traveler's Hotel Design Review Report, Sacramento, CA. Deputy Project Manager.** Eryn conducted the fieldwork and research, and prepared the design review report evaluating the proposed design changes to the historic Traveler's Hotel, built in 1914, to determine if they comply with the Secretary of the Interior's Standards for Rehabilitation. The report identified the character-defining features of the exterior and interior lobby features, identified the project's effects on the historic integrity of the hotel, including alterations to the building's character-defining features, and made recommended design changes to mitigate potential adverse project impacts.

**Silva Stowell Architects, D.O. Mills Bank Design Review Report, Sacramento, CA. Project Manager.** Eryn conducted the fieldwork and research, and is preparing the design review report evaluating the proposed design changes to the historic D.O. Mills Bank, built in 1912, to determine if they comply with the Secretary of the Interior's Standards for Rehabilitation. The report will identify the character-defining features of the exterior and interior features, identify the project's effects on the historic integrity of the hotel, and make recommended design changes to mitigate potential adverse project impacts.

**Prior to ESA**

**October 2011-May 2015**



Urban Planner/Architectural Historian, AKRF, Inc., New York, NY

**September 2008-September 2011**

Senior Planner, Community Development Department, Albemarle County, VA

**July 2006-September 2008**

Director of Development & Communications, Falmouth Heritage Renewal, Falmouth, Jamaica/Charlottesville, VA

**Publications**

“S.J. Makielski: Designer of African-American Schools for the Episcopal Church in the Rural South, 1930-1944,” *ARRIS* 22 (2011): 49-69.

Images of America Series: Charlottesville, coauthored with Margaret Maliszewski. Charleston, South Carolina: Arcadia Publishing, 2011.

“The Showers Brothers Factory: Tradition and Innovation in Architecture and Urban Design” (alternate title), *Midwestern Folklore*, Spring 2011 edition.

“Falmouth Heritage Renewal: A Sustainable Approach to Conservation,” *Traditional Masonry Magazine*, July 2008, 19-23.

“Falmouth Heritage Renewal: Improving Lives Through Preservation,” *The Georgian*, February 2008, 10-12.

**Teaching**

**Department of Urban and Environmental Planning, University of Virginia, VA. Adjunct Faculty Member.** Eryn served as Adjunct Faculty and taught the graduate Preservation Planning seminar in the Department of Urban and Environmental Planning. Eryn lectured on topics related to preservation planning at the national, state, and local levels, and facilitated discussions on a wide range of preservation issues.

**Department of Continuing Studies, Stanford University, Palo Alto, CA. Adjunct Faculty Member.** In the summer of 2016, Eryn co-taught a course on the history of San Francisco beginning with pre-European contact and concluding with the 1915 Panama-Pacific International Exhibition.



# Heidi Koenig, RPA

## Cultural Resources

### EDUCATION

M.A., Cultural Resources Management, Sonoma State University

B.A., Anthropology, San Francisco State University

### 15 YEARS EXPERIENCE

### CERTIFICATIONS/REGISTRATION

Register of Professional Archaeologists (RPA), 15140

Hazardous Waste Operations and Emergency Response 40 hour course completion and active renewal

### PROFESSIONAL AFFILIATIONS

Society for California Archaeology

Society for Historical Archaeology

Heidi is a Registered Professional Archaeologist specializing in California archaeology. She has prepared numerous cultural resources studies in compliance with the California Environmental Quality Act and Section 106 of the National Historic Preservation Act, including surface surveys, subsurface surveys, site significance evaluation, mitigation recommendations, and consultation with the State Historic Preservation Officer. Heidi has developed several interactive GIS databases to assist regulatory agencies with cultural resources management and preservation decisions. Heidi has conducted numerous records searches at the California Historical Resources Information System and has assisted with consultation efforts with several Native American tribes.

### Relevant Experience

**Kaiser Center Development Project, Oakland, Alameda County.** *Archaeologist.* Heidi conducted a site sensitivity study for the Kaiser Center Development Project in downtown Oakland near Lake Merritt. The records search and a review of historic documents and maps indicated that the project area was once the location of a convent and boarding school. The Convent of Our Lady of the Sacred Heart was established in 1868 and remained at the location until 1957. It was determined that archaeological deposits and features associated with the school could exist beneath the current building and be exposed during ground-disturbing activity. Recommendations included the development of a research design and testing program that would appropriately mitigate any adverse impacts to significant cultural resources.

**Richmond Shoreline Specific Plan, Richmond, Alameda County.** *Archaeologist.* Heidi prepared the cultural resources section of the Environmental Impact Report for the Richmond Shoreline Specific Plan. The Specific Plan area includes one of the largest archaeological sites in the San Francisco Bay Area – the National Register of Historic Places listed Stege Mound Archaeological District. Heidi recommended that due sensitivity for archaeological sites, the high potential for buried sites that would not be visible due to development, and the lack of specific ground-disturbing impact proposals warrant comprehensive archaeological study and survey for individual projects once development plans have been outlined in order to determine the presence or absence of archaeological resources, related with proposed impacts of site-specific development.

**North Richmond Specific Plan, Richmond, Alameda County.** *Archaeologist.* Heidi prepared the archaeological component of the cultural resources section for the North Richmond Specific Plan Environmental Impact Report. The Contra Costa County Board of Supervisors authorized a General Plan Amendment study to redesignate 57 acres of land now designated for industrial use to a mix of residential, commercial, open space, and public uses in support of a master-planned residential development. Heidi conducted a records search and reconnaissance field survey for archaeological sites.

**LAVWMA Pipeline Connection Project, San Leandro, Alameda County.**

*Archaeologist.* Heidi completed the archaeological study for the Livermore-Amador Valley Water Management Agency (LAVWMA) 1,200-foot pipeline connection project at Roberts Landing. The project extends through a previously recorded cultural resource that includes former Roberts Landing, the Trojan Powder Works remains, the 'Caretaker's Residence' remains, and the Bluebird Dump. The site was previously determined not eligible for listing on the National Register of Historic Places. This previous evaluation was reconfirmed during a supplemental survey and recommendations.

**North San Pablo Bay Restoration and Reuse Project, Sonoma, Marin, and Napa Counties.**

*Archaeologist.* Heidi prepared the cultural resources section for four wastewater utilities and one water agency in the North San Pablo Bay region of California who have joined forces to plan a project that would considerably expand the use of recycled water region wide. The study area includes pipeline segments throughout Marin, Sonoma, and Napa counties. A records search and several updates were conducted at the Northwest Information Center of the California Historical Resources Information System. Approximately 250 archaeological sites and historic structures have been previously recorded within the study area. Surface surveys and extended subsurface surveys were conducted to assess previously known archaeological resources and determine whether additional resources may be affected by the project. A finding of No Adverse Effect to Historic Properties was determined by the lead agency, the Bureau of Reclamation.

**BART VTA Berryessa Extension Project, Santa Clara County.**

*Archaeologist.* Heidi, with R. Scott Baxter, acted as Co-Field Directors for the BART project, which included historical archaeological pre-construction testing and reporting of areas determined archaeologically sensitive, in coordination with Far Western and VTA staff. Heidi completed Silicon Valley Rapid Transit Project Safety Training, as well as Hazardous Waste Operations and Emergency Response (HAZWOPER) training, specifically for working in the BART right-of-way.

**Town of Windsor Keiser Park, Windsor, Sonoma County.**

*Archaeologist.* Heidi prepared the cultural resources analysis for the 27-acre Keiser Park project area in the Town of Windsor. The proposed project includes the construction of a recreation center, an aquatic center with two swimming pools, two small ball fields with soccer field overlays, one lighted ball field, restrooms, and two children's play areas. Heidi conducted a records search for previous cultural resource documents in and surrounding the project area, consulted with Native American organizations and individuals with interest in the location, performed an intensive field survey, recorded a historic-period structure flat, and provided mitigation recommendations to reduce impacts.

**SFPUC, Groundwater Project, San Francisco.**

*Archaeologist.* Heidi prepared the Historic Context and Archaeological Survey Report for the San Francisco Groundwater Project. The project includes construction of several facilities and installation of approximately six miles of pipeline on the Westside of the City of San Francisco. The archaeological report complies with the WSIP Archaeological Guidance documents. Completed components include delineation of the archaeological CEQA Area of Potential Effects and the Historic Context and Archaeological Survey Report.



# Christie Beeman, PE

## Hydrology Program Manager

### EDUCATION

M.S., Civil and Environmental Engineering (Environmental Water Resources), University of California, Berkeley

B.S., Geology and Geophysics, Yale University

### 23 YEARS EXPERIENCE

### CERTIFICATIONS/REGISTRATION

Civil Engineer, CA, C65170

Christie Beeman is a water resources engineer with a background in surface hydrology, fluvial geomorphology, and open channel hydraulics. Her technical experience includes creek restoration, stormwater management, flood control, hydraulic modeling, and wetlands restoration and design. Christie has managed projects that include floodplain and urban creek enhancement, large-scale creek restoration, flood management, stormwater quality and hydrograph modification management, seasonal and tidal wetlands, and hydrologic monitoring and assessment. She specializes in the management of multi-disciplinary projects that require integration of habitat, flood management, public access and other objectives.

### Relevant Experience

**Santa Clara Valley Water District, Stream Maintenance Guidelines.** *Project Manager.* ESA is developing Stream Maintenance Guidelines for ten creeks in Santa Clara County: Matadero; Calabazas; Berryessa; Stevens, San Tomas Aquino; Llagas; West Branch Llagas; Los Gatos; Lower Penitencia and Golf. The project includes field surveying and flow monitoring, hydraulic analysis and development of maintenance guidelines. ESA developed a quantitative approach for identifying channel conditions that trigger the need for maintenance based on hydraulic analysis of channel flow capacity.

**Oak Knoll Venture Acquisition, L.L.C., Rifle Range Creek Restoration.** *Project Manager.* ESA is providing hydrologic and hydraulic analysis, creek restoration design and permitting support services associated with the restoration of Rifle Range Creek at the former Oak Knoll Naval Hospital site in Oakland. Creek restoration is being undertaken in conjunction with redevelopment of the site for housing and commercial uses.

**City of Concord, Concord Naval Weapons Station Redevelopment.** *Project Manager.* ESA is providing analysis and design services related to Mt Diablo Creek in support of the City of Concord's planning for redevelopment of the CNWS site. We developed a conceptual flood management and restoration plan for Mt. Diablo Creek on the CNWS site. ESA previously helped prepare the project EIR as a subconsultant to Arup, evaluating potential impacts of redevelopment alternatives related to hydrology and water quality.

**Wildlands, Inc., San Luis Rey River Wetland Mitigation Bank.** *Stormwater Task Manager.* ESA worked with Wildlands to design a 41-acre floodplain restoration project along the San Luis Rey River in Oceanside, San Diego County, CA. In addition to developing the design, ESA developed a hydrology report and geomorphic basis for the channel restoration, provided permitting support, and prepared CLOMR and LOMR applications for submittal to FEMA.

**Contra Costa County Flood Control and Water Conservation District, Lower Walnut Creek Restoration Project.** *Project Director.* ESA is leading a team to provide planning services for the Lower Walnut Creek Restoration project. The work includes planning, stakeholder outreach and facilitation, hydraulic analysis and preparation of a feasibility study recommending a preferred alternative for creek restoration.

**California Department of Water Resources, Dutch Slough Restoration.** *Hydraulic Analysis Task Manager.* The project will restore a diversity of tidal wetland, riparian, and coastal dune habitats to a 1,200-acre site currently used for grazing and dairy operations. The project is significant in two ways: (1) it is the first planned large-scale tidal wetland restoration in the Delta and (2) it is designed within an adaptive management framework to test different restoration approaches. ESA worked with a multi-agency Project Management Team and an interdisciplinary panel of scientists to develop the conceptual restoration plan and now preparing the final designs.

**Napa County, Napa River Oakville Bridge.** *Stormwater Task Manager.* CALTRANS and Napa County Public Works Department are replacing the Oakville Road Bridge, which has been undercut over time by channel incision. The existing bridge riprap poses a partial barrier to fish passage at low flows, and removing the riprap introduces the potential for downstream channel incision to migrate upstream, threatening property and recently restored in-channel habitat. ESA developed engineering plans for a channel structure that would protect the bridge footing, arrest channel incision and provide fish passage for steelhead and Chinook salmon.

**Sonoma County Water Agency, Flood Control and Design Criteria Manual Update.** *Project Staff.* ESA is updating the Flood Control and Design Criteria Manual (FCDC) for the Sonoma County Water Agency. The FCDC provides the guidelines for channel and closed conduit design for projects under the jurisdiction of SCWA. Working with Horizon Water and Environment, ESA is helping to revise the FCDC to accommodate a more integrated approach to hydrologic management while remaining focused on the water agency's mission and authority.

**City of Oakland Public Works Agency, Department of Engineering, Water Quality and Restoration As-needed Contract.** *Project Director.* ESA is providing water quality, stormwater management and restoration services on an as-needed basis to the City of Oakland. Under this contract, Christie has overseen numerous task orders related to NPDES compliance, project monitoring, permitting and field data collection.

**Napa County, Napa River Restoration – Rutherford and Oakville to Oak Knoll Reaches.** *Hydraulic Analysis Task Manager.* ESA is leading a multidisciplinary technical team to work collaboratively with the Rutherford DUST Society and Napa County for the final design of river and habitat enhancement. The project involves geomorphic streambank and channel assessments for 13.5 miles of the Napa River leading to restoration designs for salmonid refuge, spawning and rearing habitats. ESA performed hydraulic analyses to support the development of the final design as well as FEMA compliance. We have coordinated closely with County staff to evaluate and document the potential effect of this and other related projects on the FEMA regulatory floodplain.



# Dana McGowan, RPA

## Cultural Resources Practice Leader

### EDUCATION

M.A. Anthropology,  
California State  
University, Sacramento

B.A. Anthropology  
(minor in Geology),  
California State  
University, Sacramento

### 34 YEARS EXPERIENCE

### CERTIFICATIONS/ REGISTRATION

Register of Professional  
Archaeologists (RPA),  
#10697

### PROFESSIONAL AFFILIATIONS

Society for American  
Archaeology

Society for Historical  
Archaeology (Annual  
Conference Chair 2006)

Society for California  
Archaeology (President  
2002-2003)

American Cultural  
Resources Association  
(Vice President 1995-  
1998; Board Member  
1995-2001)

### AWARDS

The 1996 California  
Preservation Foundation  
Award,

The 1996 National  
Interpretive Association  
Award

The 1996 California  
Association of  
Environmental  
Professionals Award

The 1994 Chief of  
Engineers'  
Environmental Design  
Award

### General Bio

Dana McGowan is a registered professional archaeologist and an expert in National Environmental Policy Act of 1969 (NEPA), California Environmental Quality Act of 1970 (CEQA), and Section 106 of the National Historic Preservation Act of 1966 (NHPA) compliance. She has over 34 years of experience managing environmental analysis and documentation for complex projects and the development and implementation of environmental documentation and implementation programs. Dana serves as the firm's Cultural Resources Practice Leader, leading a team of 60 cultural resources experts including prehistoric, historical, and maritime archaeologists, field monitors, historians, architectural historians, preservation planners, and curation specialists. Dana has extensive experience in conducting environmental work for all types of infrastructure, including transportation, water, and energy projects, as well as wide-ranging rail experience and management of environmental compliance for construction projects. She has worked on some of the largest and most complex environmental documents produced at the time, including Base Realignment and Closure Act projects (Presidio of San Francisco, Hamilton Army Airfield, Fort Ord), water supply and flood control projects (Central Valley Improvement Act EIR/S, Mono Water Rights EIR, Bay Delta Conservation Plan EIR/S, Los Vaqueros Reservoir Project), and a large number of transportation projects (Doyle Drive Replacement Project, the Legacy Parkway Project in Utah, and the Desert Xpress (now Xpress West) High Speed Train from Victorville to Las Vegas, Nevada EIS). Prior to joining ESA, Dana served as Senior Cultural Resources Manager assisting the Authority in the oversight of the cultural resources and environmental compliance work needed during construction. She then transitioned to being the Environmental Manager for the entire California High Speed Rail Project, overseeing a team of in-house environmental experts and a pool of environmental consultants preparing environmental documents for the multiple sections of 800-mile long California High Speed Rail Project.

### Relevant Experience

**California High Speed Rail Project, California.** *Senior Cultural Resources Manager/Environmental Manager.* Working as an extension of California High Speed Rail Authority staff for Parsons Brinckerhoff, Dana served first as Senior Cultural Resources Manager assisting the Authority in the oversight of the cultural resources and environmental compliance work needed during construction for this highly complex project. Following this assignment, Dana became the Environmental Manager for the entire California High Speed Rail Project, overseeing a team of in-house environmental experts and a pool of environmental consultants preparing environmental documents for the multiple sections of 800-mile long High Speed Rail Project.

**San Francisco Transportation Authority, Doyle Drive Project within Presidio of San Francisco National Historic Landmark, San Francisco, CA.** *Project Director/Program Manager.* Served as project director and program manager for a 12-year program of identification, evaluation, mitigation, and monitoring for a new roadway through the Presidio National Historic Landmark in compliance with NEPA, CEQA, and Section 106 of the NHPA. The project included test excavations, over 10 different technical studies, preparing a multiagency programmatic agreement and coordination with 5 federal agencies, two state agencies and several local jurisdictions, and well as numerous Native American groups. Numerous types of mitigation were conducted including Historic American Building Survey (HABS), Historic American Engineering Record (HAER), and Historic American Landscape Survey documentation. The project went into construction in 2009.

**Delta Wetlands, Inc., Delta Wetlands Project, California.** *Cultural Resources Lead.* In compliance with NEPA, CEQA, and Section 106 of the NHPA, Dana conducted technical studies, prepared an MOA and oversaw the work of team members preparing studies for the development of the Delta Wetlands Project, a program to convert Delta Islands to off-stream water storage facilities. Resources included Piper Sand Mound burial sites and architectural resources associated with the early Japanese occupation and use of the area.

**U.S. Forest Service, Region 5; Various Task Orders throughout California.** *Project Manager.* Dana managed over 30 cultural resources work assignments under the on-call services contract. Work was conducted throughout California, including the Mendocino, Shasta-Trinity, Tahoe, Eldorado, Sequoia, Angeles, and Los Padres National Forests. Projects included archaeological surveys for prehistoric and historic resources, archaeological test excavations, architectural inventories, National Register of Historic Places evaluations and nominations for historic and prehistoric resources, and Points of Historical Interest applications. Under this contract, Dana also assisted in the development of protocols and memoranda of agreement which outlined the processes for Native American and agency (USFS and U.S. Bureau of Land Management) interaction to facilitate project implementation. She also assisted in the inventory, evaluation, and nomination of 45 miles of Carson Emigrant Trail including ethnographic research regarding Washoe use of the trail, GPS documentation of the trail location, and a landscape analysis of the trail route.

**Contra Costa County Water District, Los Vaqueros Reservoir Project, California.** *Cultural Resources Lead.* Dana managed the cultural resources studies including archaeological, architectural, and ethnographic studies; regulatory compliance including drafting the MOA in compliance with Section 106 for the 24,000-acre Los Vaqueros Reservoir Project.

**ERM, Sacramento Railyards Remediation Monitoring Program. Cultural Resources Lead.** Prior to joining ESA Dana oversaw the multi-year archaeological monitoring and assessment program for the remediation of the Railyards.

**USACE, Sacramento District, Various Task Order Assignments. Project Director.** Prior to joining ESA, Dana conducted an inventory and evaluation of Cold War properties and development of a cultural resources management plan and historic properties maintenance manual for McClellan Air Force Base.





# Becky Urbano

---

## Senior Architectural Historian

### EDUCATION

M.S., Science in  
Historic  
Preservation,  
Columbia University,  
New York, NY

B.A., Physics,  
Middlebury College,  
Middlebury, VT

### 13 YEARS EXPERIENCE

### PROFESSIONAL AFFILIATIONS

Sacred Sites  
International (Board  
Member)

California  
Preservation  
Foundation

National Trust for  
Historic Places

Oakland Heritage  
Alliance

Becky is a Cultural Resources Project Manager with 13 years of experience in materials science, on-site investigations, compliance regulation requirements (CEQA, NEPA, Section 106, Section 110, etc.) and environmental review procedures. She has knowledge of a wide range of local archives and historical resources and has a direct understanding of the unique challenges within various regulatory frameworks at the local, state, and federal levels. Becky is a proven client and team manager with successful project management strategies for complex resource management issues.

### Relevant Experience

**Marysville Bok Kai Temple, Vibrations Impact Analysis Report.**

**Marysville Downtown Historic Commercial District, Vibrations Impact Analysis Report**

**Hangar One, Conditions Assessment Report and Rehabilitation Report**

**Angel Island Immigration Station Hospital, Conditions Assessment Report and HSR Supplement**

**Alcatraz Island, Transportation Study Planning and EIS**

**Doyle Drive Environmental Review, Section 106 Compliance Reports**

**San Francisco Auxiliary Water Supply System (AWSS), Upgrade Mitigation and Compliance Consultation**

**Lorenz Hotel, Federal Historic Tax Credit Application Resource Planning and Management**

**Columbia State Historic Park, Cultural Landscape Management Report**

**Monterey Custom House, Historic Structure Report**

**City of Hayward, Context Statement**

**Angel Island Immigration Station Hospital Rehabilitation Architectural Program**

### Publications and Presentations

*The Secretary of the Interior's Standards for the Treatment of Historic Properties: A Primer*, California Preservation Foundation webinar

*Alphabet Soup: Preservation Acronyms for Every Occasion*, California Preservation Foundation webinar

*How Do We Honor What Matters To Us?*, California Preservation Foundation Conference Session Presentation

*Preservation Planning and Resource Stewardship*, Preston Castle Foundation Board Training



## Michael Ratte

### Senior Air Quality Scientist, Environmental Services

Michael Ratte is a Senior Air Quality Scientist at RCH Group. Mike has been a practicing meteorologist and air quality specialist within the consulting business for 25 years. Mike's technical expertise includes CEQA/NEPA environmental planning, air emissions inventories, ambient air monitoring, atmospheric dispersion modeling, General Conformity determinations, CO/PM roadway intersection hot-spot analysis, air quality permitting, health risk assessments, and climate change analyses.

Mike has worked extensively for local, state, and federal agencies, as well as a wide array of commercial businesses and industries. His recent projects involved transportation facilities (airports, roadways, and marine ports), land development (residential/commercial/institutional), landfills, and quarry operations. He has conducted air quality analysis for over 30 airport CEQA/NEPA documents.

Mike is well versed in a wide array of air emission models including, EMFAC, OFFROAD, NONROAD, MOVES, CALEEMod, and AP-42; dispersion models such as AERMOD, CAL2QHC, EDMS/AEDT, and HARP; with strong data management and ACCESS programming skills.

### CEQA/NEPA Project Experience

- **Residential/Commercial Development CEQA documents:** 127 West Harris Ave Hotel IS/MND, 150 Airport Blvd IS/MND, 1525 Alviso Street IS/MND, 2117 Carlmont Drive IS/MND, 255 Cypress Avenue IS/MND, 418 Linden Ave IS/MND, 488 Linden Avenue IS/MND, 550 Gateway Blvd hotel IS/MND, 699 Ralston Avenue IS/MND, 830 Marina Way South (Bay Walk) IS/MND, American Canyon Green Road Wine Warehouse IS/MND, Brisbane Baylands EIR, Broadway Plaza EIR, Centennial Towers IS/MND, Centennial Hotel IS/MND, Central Amador Water Pioneer Water Rehabilitation IS/MND, Crystal Springs Upland School IS/MND, Colfax Sierra Oaks Estates and Village Oaks Apartments IS/MND, East Bay Regional Park District Public Safety Modernization IS/MND, Fair Deal Waste Recycling and Transfer Station IS/MND, First and Campbell Retail IS/MND, Folsom Parkway Parcel A Apartment Complex IS/MND, Gimbals Candies Expansion IS/MND, John Henry High School CEQA Exemption, Lafayette Town Center IS/MND, Lakeside Fire Station IS/MND, Life Sciences Campus IS/MND, Lincoln Northeast Quad Specific Plan, Linden Commuter Bus Facility IS/MND, Morgan Knolls IS/MND, Nevin Avenue Apartments IS/MND, Park SFO IS/MND, Oak Knoll Mixed Use Community Plan EIR, Oakland T12 Office Tower, Port of Richmond Honda Port of Entry EIR, Port of Richmond Terminal 3 Log Export Facility IS/MND, Osgood Heights IS/MND, Residences at Railway IS/MND, Pruneyard Shopping Center, Richmond John Henry High School Peer Review, Richmond South Shoreline Specific Plan HRA, Rocklin Sunset & Pacific IS/MND, Sea Ranch Fiber Optic Cable Project IS/MND, Sunnyvale Atria on El Camino Real IS/MND, Treasure Island EIR, UCSF Long Term Development Plan EIR, UCSF Research Building and Parking Garage Expansion EIR, Ukiah Walmart EIR, Westborough Shopping Center Redevelopment IS/MND, William Jenkins Medical Center CEQA Exemption

- **Restoration/Recreational CEQA documents:** Alameda Creek North Levee Improvements IS/MND, Lower Berryessa Creek EIR, Lower Yolo Restoration EIR, Moss Landing Desalination Plant EIR, Oasis Area Irrigation System Expansion EIR, Phillips 66 Oil Spill Remediation IS/MND, Putah Creek Restoration Project IS/MND, Rockville Trails Preserve IS/MND
- **Quarrying/Mining CEQA documents:** Olive Pit Mine EIR, Permanente Quarry Reclamation Plan Amendment EIR, Pilarcitos Quarry Expansion EIR, R&J Aggregate Mine EIR, Roblar Road Quarry EIR, San Rafael Rock Quarry EIR, Vernalis Quarry EIR
- **Energy/Transmission CEQA documents:** Eagle Mountain Pumped Storage Hydroelectric EIR/EIS, California Public Utilities Commission Bakersfield Power Connect 230 kV Project, California Public Utilities Commission Fulton-Fitch Mountain Reconductoring Project, California Public Utilities Commission Riverside Transmission Reliability Project, SDG&E TL 695, TL 6971 Reconductoring Project
- **Material Recovery Facility/Transfer Station/Landfill CEQA documents:** Forward Landfill Expansion EIR, Glenn County Landfill EIR, Irwindale Athens Services Materials Recovery Facility/Transfer Station EIR, Keller Canyon Landfill EIR, Milpitas Odor Assessment, San Luis Obispo Anaerobic Digester IS/MND, Sonoma Compost EIR
- **Airport CEQA/NEPA documents:** Baltimore International Airport Improvement Program EA, Baltimore International Airport Proposed Hotel EA, Burbank Airport Terminal Relocation EIR, Chicago O'Hare International Modernization Program EIS, Chicago O'Hare International Re-Evaluation EIS, East Hampton Airport Control Tower EA, Fresno Yosemite International Airport Runway Safety Area EA, Gooding (Idaho) Municipal Airport EA, Houston Hobby Airport International Service EA, Kaiser Air Oakland Airport North Field EIR, LaGuardia International Airport Runway Safety Area EA, Louis Armstrong New Orleans International Airport Terminal Relocation EA, Manchester-Boston Regional Airport Emission Inventory, March Inland Port General Aviation Development EA/EIR, Minneapolis-St. Paul International Airport 2020 Improvements EA, Nut Tree Airport Master Plan EIR, Oakland International Airport Runway Safety Area EA, Palm Springs International Airport Master Plan Update EA, Philadelphia International Airport Capacity Enhancement Program General Conformity Determination, Philadelphia International Airport Capacity Enhancement Program EIS, Portland International Airport Runway Extension EA, Providence Airport Runway Extension EIS, Riverside Airport Master Plan EA, Sacramento International Airport Terminal Expansion EIR, San Diego International Airport Master Plan EIR, San Francisco International Airport Runway Safety Area EA, Santa Maria Airport Master Plan Update EA, Southern Nevada Supplemental Airport EIS
- **Airport Planning/Research:** Baltimore International Airport Air Quality Management Plan, Boston Logan International Airport Environmental Data Report, George Bush Intercontinental Airport State Implementation Plan Emissions Inventory, Los Angeles World Airports Air Quality Sources Apportionment Study, Los Angeles World Airports Extremely Low Emissions GSE Feasibility Study, Monterey Regional Airport Greenhouse Gas Emissions Inventory, Philadelphia International Airport Greenhouse Gas Emissions Inventory, San Diego International Airport VALE Application, Transportation Research Board Airport Cooperative Research Program ACRP 02-21: Evaluation of Airport Emissions within State Implementation Plans, San Diego International Airport Air Quality Management Plan, Santa Barbara Airport Greenhouse Gas Emissions Inventory, South Jersey Transportation Planning Organization Greenhouse Gas Emissions inventory, ACRP 02-23: Alternative Fuels as A Means to Reduce PM<sub>2.5</sub> Emissions at Airports, ACRP 02-43: Development of NO<sub>x</sub> Chemistry Module for EDMS/AEDT to Predict NO<sub>2</sub> Concentrations, Federal Aviation Administration Air Quality Handbook

**Education**

1989 BS Meteorology, Lyndon State College – Lyndonville, Vermont

**Professional Affiliations**

- Member, Association of Environmental Professionals
- Member, Air and Waste Management Association

**25 Years Consulting Experience**

- TRC
- Radian/URS
- Environmental Science Associates
- KB Environmental Sciences



## **Marsha Gale**

*Managing Principal*

### **Expertise**

Marsha Gale has more than 30 years of professional experience in the fields of environmental planning and design. She has particular expertise in aesthetic design and is highly familiar with visual impact assessment methods. Ms. Gale brings extensive CEQA experience on projects located throughout the Bay Area including hospital and medical facilities, residential and mixed use developments, campus and major infrastructure improvements. As principal-in-charge she directs complex visual and aesthetic design studies that include accurate and highly realistic computer-generated simulations and shadow impact modeling.

Ms. Gale has pioneered the use of computer imaging applications for project planning, design, analysis, and communication. She has made technical presentations to numerous public decision-making bodies and has lectured internationally on the subject of visual simulation techniques for environmental planning and design. Ms. Gale is a member of the American Society of Landscape Architects and the Urban Land Institute.

### **Representative Project Experience**

- AgeSong Senior Housing Development - Emeryville, California
- Kaiser Medical Center Replacement Project EIR –Oakland, CA
- San Francisco General Hospital Rebuild Project EIR - San Francisco, CA
- Kaiser Medical Office Building Complex– Pinole, CA
- Kaiser Hospital and Medical Center Master Plan – Vallejo, CA
- Emergency Response Center Project EIR- University of California, Santa Cruz Campus
- Saint Mary's Campus Master Plan EIR - Moraga CA
- Stanford Medical Development EIR – Palo Alto, CA
- Union City Intermodal Station Project – Union City, CA
- Russell City Energy Center- Hayward, CA
- Oak Grove Hillside Residential Development EIR - Pleasanton, CA
- UCSF Medical Campus Improvements: Parnassus Heights, Laurel Heights and Mission Bay Campus

### **Education**

Bachelors in Landscape Architecture, University of Illinois at Champaign/Urbana

Masters in Landscape Architecture, University of California at Berkeley

Masters in City & Regional Planning, University of California at Berkeley



## **Charles Cornwall**

*Principal*

### **Expertise**

Charles Cornwall has more than 28 years of professional experience in the fields of environmental and landscape planning. He provides advanced computer simulation and modeling expertise and is also an accomplished visual analyst and environmental planner experienced with project impact assessment and mitigation design. Employing a variety of software and hardware platforms, Mr. Cornwall has developed innovative computer techniques for high-resolution visual simulation and visual analysis and is also an expert in digital photo-documentation techniques. His experience on a wide variety of developments and infrastructure improvements located throughout the Bay Area includes numerous hospital, medical facility, residential and campus projects.

Mr. Cornwall is a member of the American Planning Association and Association of Environmental Professionals. He has presented to the American Society of Landscape Architects, U.S. Forest Service, and university classes on the subject of computer simulation and visual assessment techniques. Mr. Cornwall has also provided professional computer training to landscape architects at the California Department of Transportation and U.S. Forest Service.

### **Representative Project Experience**

- AgeSong Senior Housing Development - Emeryville, California
- Kaiser Medical Center Replacement Project EIR –Oakland, CA
- Kaiser Potrero Project– San Francisco, CA
- San Francisco General Hospital Rebuild Project EIR - San Francisco, CA
- Kaiser Hospital and Medical Center Master Plan – Vallejo, CA
- Kaiser Medical Center – Pinole, CA
- Saint Mary's Campus Master Plan EIR - Moraga CA
- Stanford Medical Development EIR – Palo Alto, CA
- Union City Intermodal Station Project – Union City, CA
- UCSF Medical Campus Improvements: Parnassus Heights, Laurel Heights and Mission Bay Campus
- Russell City Energy Center- Hayward, CA
- Altieri Residential Property Development – Pleasanton, California
- Oak Grove Hillside Residential Development EIR – Pleasanton, California
- D Street Residential Development – Alameda County, California

### **Education**

Masters in Landscape Architecture, University of California at Berkeley

Bachelors in Conservation of Natural Resources, University of California at Berkeley

# **Appendix L**

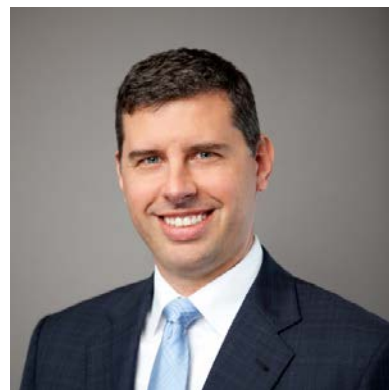
## **Project Sponsor's Technical Team Qualifications**



# MICHAEL KEINATH

## Principal

Michael Keinath has over 15 years of experience in environmental science and engineering, with special emphasis on air quality and climate change, human health risk assessment, air modeling and air monitoring. He has advised clients from various industries, including ports and rail, quarries and mines, foundries and recyclers, chemical manufacturers and consumer products suppliers, in addition to property developers and local planning agencies. Michael has estimated emissions, modeled dispersion and measured ambient and indoor concentrations of numerous sources of airborne contaminants, using the results to conduct human health risk assessments under federal, state and local regulations, including California's Environmental Quality Act (CEQA), Proposition 65 (Prop65) and the Air Toxics "Hot Spots" Program (AB2588). He is currently leading Ramboll Environ's next-generation air monitoring (NGAM) task force, investigating how low-cost, distributed sensor technology and "big-data" analysis can be deployed in cost-effective, scientifically-robust ways.



## CONTACT INFORMATION

### Michael Keinath

[mkeinath@ramboll.com](mailto:mkeinath@ramboll.com)  
+1 (415) 796-1934

Ramboll  
201 California Street  
Suite 1200  
San Francisco, 94111  
United States of America

## EXPERIENCE HIGHLIGHTS

- On behalf of the San Francisco Planning Department, conducted air dispersion modeling of all roadways (over 28,000 segments) for a 20 x 20 meter grid throughout the City and County of San Francisco (over 240,000 receptor points). We also conducted a peer review of the Bay Area Air Quality Management District's modeling of all toxic air contaminant sources, including stationary sources, commuter rail and marine (ferry, cruise ship) sources. This modeling was then used to develop the Air Pollution Exposure Zones and the Department of Public Health's amended Article 38 in 2014. In 2016, we updated this analysis for new sources, a longer time horizon and updated risk assessment guidance and assisted the city in developing a Community Risk Reduction Plan.
- For an addendum to the original environmental impact report for the Oakland Army Base (OAB) Area Redevelopment Plan, which will transform the facility into a state of the art intermodal logistics center, Michael led Ramboll Environ's effort to evaluate the potential air quality and health risk impacts from the OAB. The evaluation evaluated emissions and assessed the risks and hazards associated with additional diesel particulate matter emitted from trucks, train engines and ships that will result from the project from both construction and operation. To do so, ENVIRON used USEPA tools and our extensive experience evaluating emissions from rail yards and ports throughout

## CREDENTIALS

MSE, Chemical Engineering,  
University of Michigan, 1999  
MSE, Environmental  
Engineering, University of  
Michigan, 1998  
BS, Chemical Engineering,  
Stanford University, 1996  
Registered Professional  
Engineer (Chemical),  
California, CH 6275



California (including Ports of Oakland, Los Angeles, Long Beach, San Diego and San Francisco).

- For the Candlestick Point-Hunters Point Shipyard Phase II Development Plan Project in San Francisco, California, evaluated air quality impacts and prepared CEQA air quality documentation for project and its variants and alternatives, including identification and quantification of mitigation measures. Additionally, led human health risk assessment effort to quantify and document potential impacts of diesel exhaust from nineteen years of construction activities, contaminated dust generation from construction activities on the brownfield site, fine particulate matter (PM2.5) from traffic associated with project, and the variety of sources of emissions which could be located in designated R&D areas.
- For CEQA purposes, conducted air quality and climate change analyses for the California Pacific Medical Center Long Range Development Plan, which involved new construction, renovation and replacement of hospital and medical office building facilities at multiple locations in San Francisco, including an evaluation of how LEED (Leadership in Energy and Environmental Design) measures would impact the carbon footprint of the facilities. This included a human health risk assessment for exposure to diesel exhaust associated with construction equipment and advising client on potential mitigation measures to minimize impacts to sensitive on-site and off-site populations.
- For CEQA purposes, conducted a human health risk assessment for exposure to diesel exhaust associated with construction equipment used for the Stanford University Medical Center Project, which renews and replaces facilities due to state-mandate seismic safety laws, a shortage of patient beds, changing patient needs, outdated facilities and the need to further new advances in medical care. The project includes the replacement and expansion of Stanford Hospital & Clinics, expansion of Lucile Packard Children's Hospital, a new medical office building and replacement of several of the Stanford University School of Medicine laboratory buildings. Advised client on potential mitigation measures to minimize impacts to sensitive on-site and off-site populations. Also evaluated operational emissions such as diesel-fueled emergency backup generators, truck traffic to and from the facility and emissions from medical helicopters which transport patients and organs to and from the facility.
- On behalf of the City of Oakland, conducted a peer review of the air dispersion modeling and health risk assessment for the Children's Hospital Oakland EIR.
- For a regional medical center long range development plan, evaluated air quality and human health impacts.
- Led effort to develop an innovative three-dimensional planning tool which allows decision makers and architects to design a new medical facility in a configuration that minimizes the impact of exhaust from traffic on two freeways adjacent to the proposed site.
- For the University of California San Francisco Mission Bay campus, conducted a campus-wide human health risk assessment of existing sources and planned future expansion, including the hospital, for use in strategic planning. Evaluated impacts to onsite sensitive receptors such as children in daycare and residents in dormitories or family housing, as well as impacts to surrounding community.
- Prepared an analysis of life cycle GHG emission from alternative energy types and building materials to assist client in designing a "Sustainable City." Because life cycle analyses methodologies are not standardized, it is difficult to compare life cycle analyses from different studies. Ramboll Environ reviewed studies from the literature and placed the studies into context considering the different methods used and boundaries drawn.
- In support of the CEQA analyses for the 34th America's Cup (AC34) yacht races and James R. Herman Cruise Terminal Project in San Francisco, California led the air quality and human health risk assessment effort in evaluating impacts of construction of the race venues, team bases, and cruise terminal as well as race-day activities including support vessels and excursion craft. Additionally, evaluated potential opportunities for mitigation including the installation of shoreside power for a dry dock leased by the Port of San Francisco.

# CATHERINE MUKAI

## Senior Manager

Catherine Mukai has expertise in air emissions and concentration impact assessment, using fundamental skills in emissions estimation, regulatory analysis, air dispersion modeling, and health risk assessments. Ms. Mukai has provided permitting, compliance, and litigation support for industrial stationary sources and quantified emissions and concentration impacts from mobile sources, rail, and marine sources, as well. Ms. Mukai has successfully applied for permits for stationary sources of air pollution and GHG in many states and California air districts, under New Source Review and Prevention of Significant Deterioration programs. She has also prepared air quality technical reports for California Environmental Quality Act (CEQA) impact analyses of Air Quality, Greenhouse Gas, and Energy Resources.



### EXPERIENCE HIGHLIGHTS

- Air quality expert for the defense in an appeal to a state environmental protection agency hearing board of an administrative permit amendment. Significant issues include permitting for Startup, Shutdown and Maintenance, and emissions calculations.
- Wrote and reviewed EIR chapters in support of CEQA review for refinery, land-use and transportation projects. Worked on teams to submit two successful AB900 judicial streamlining applications to the governor of California, proving no net additional GHG emissions related to construction of Apple Campus 2 and the Event Center and Mixed-Use Development at Mission Bay Blocks 29-32.
- Used the CalEEMod®, EMFAC2011 and OFFROAD programs to calculate the criteria pollutant and emissions from several California land-use projects.
- Performed air dispersion modeling using the AERMOD and ISCST3 programs for various industrial stationary sources, construction projects, and land-use developments. Utilized air dispersion modeling results along with the ARB Hot Spots Analysis and Reporting Program (HARP) to perform human health risk assessments for medical centers, university campuses, bakeries, quarries, manufacturing facilities, marine terminals and other industrial sites. Performed HRAs in support of permitting, the California Assembly Bill 2588 (AB2588) "Hot Spots" program, litigation, and CEQA purposes.
- Compiled GHG emissions inventories for entities including semiconductor fabrication facilities, bus and rail systems, agricultural sources and construction equipment. Prepared annual GHG emissions inventories for a Bay Area

### CONTACT INFORMATION

**Catherine Mukai, PE**

[cmukai@environcorp.com](mailto:cmukai@environcorp.com)  
+1 (415) 426-5014

Ramboll Environ  
201 California Street  
Suite 1200  
San Francisco, 94111  
United States of America

### CREDENTIALS

MS, Environmental Engineering, University of Texas at Austin, 2008  
BS, Chemical Engineering, University of California, Berkeley, 2005  
California Professional Engineer, Chemical (CH 6604)  
California Air Resources Board-Accredited GHG Lead Verifier and Oil and Gas and Process Specialist (EO H-14-041)

semiconductor facility to meet AB32 reporting requirements. Evaluated GHG from real estate developments, including construction, in support of CEQA review.

- Completed successful permit applications for a range of emissions sources, including GHG in the Bay Area Air Quality Management District, the South Coast Air Quality Management District and a variety of other states and California districts. Types of permitted sources include refinery storage tanks, agricultural sources, material-handling sources, diesel-fired generators, and semiconductor fabrication stations.
- Wrote a top-down best available control technology (BACT) analysis for a proposed biomass-fueled power plant in support of a PSD permit application. Performed a demand growth exclusion PSD emissions analysis for a separate Title V permit modification application.
- Reviewed reported GHG emissions from an underground natural gas storage facility as Lead Verifier. Have, in addition, assisted on verification teams for electricity imports.
- Designed and implemented an on-site particulate matter (PM) monitoring program with wireless telemetry. Conducted wipe sampling for both biogenics and metals.
- Performed threshold calculations, compiled the emissions inventories and prepared reports to the USEPA for the toxic release inventories (TRI) of a petroleum refinery and a manufacturer of composite materials for the aerospace industry.
- Provided litigation support in estimating criteria air pollutant and hazardous air pollutant emissions from sources such as coke ovens, a defunct refinery tank farm, a kraft pulp and paper mill, and solvent use in manufacturing. Performed air dispersion modeling for comparison to the National Ambient Air Quality Standards (NAAQS) to address concerns of health effects from plant operation on nearby residents.
- Provided litigation assistance in a case concerning a shuttered uranium mine. Considered sources and quantities of particulate matter emissions, reviewed radon and lead monitoring data, and collected source data necessary to model dispersion of emissions from the site.



**SCOTT BATIUK, BS**

Plant Biologist

[batiuk@wra-ca.com](mailto:batiuk@wra-ca.com)

o: 415.524.7211

*Years of Experience:* 6

**Education**

B.S. Forest Resources, University of Washington. 2010.

**Professional Affiliations/Certifications**

California Native Plant Society

California Lichen Society

Southern California Botanists

**Specialized Training**

Releve and Rapid Vegetation Assessment, CNPS.

Fluvial Geomorphology and River Restoration, UCB

Certified Wetland Delineator, Wetland Training Institute

Numerous technical botanical workshops through the Jepson Herbarium at UC Berkeley and the CSU Chico Herbarium

Scott Batiuk received a Bachelor of Science degree in Forest Resources from the University of Washington, where his studies focused on forest ecology. He has worked in a wide variety of habitats in California, the Pacific Northwest, Nevada, and Uruguay, and his experience includes special-status plant surveys, plant community mapping, invasive species management, forest plot mapping, post-fire recovery monitoring, native seed collection, restoration planting, and mitigation land monitoring. In addition, Scott has training in soil science, wetland delineation, plant ecophysiology, and fluvial geomorphology. Before joining WRA, Scott worked for a variety of non-profit, academic, private, and government organizations.

At WRA, Scott’s work includes protocol level rare plant monitoring, vernal pool vegetation and hydrology monitoring, vegetation type mapping, and wetland delineation. He also works with permitting, compliance, and habitat restoration plans.

**Representative Projects**

***Special-Status Plant Monitoring, Invasive Plant Monitoring, Hydrology Monitoring, and Grazing Management, Elsie Gridley Mitigation Bank, Solano County, California – Spring 2013-Present***

The 2,000-acre Elsie Gridley Mitigation Bank, located in rural Solano County, California, encompasses the preservation of existing Sacramento Valley vernal pool habitat, creation of seasonal wetlands and vernal pools which host several species of special status plants and wildlife, and maintenance of interstitial upland grasslands. Scott has monitored and surveyed for special-status plant species; monitored, assessed, and helped to direct the treatment of invasive plant species; helped manage sitewide grazing; and monitored seasonal wetland hydrology. During special-status plant monitoring, Scott has documented and mapped several special-status species at the site, including alkali milkvetch (*Astragalus tener* var. *tener*), San Joaquin spearscale (*Extriplex joaquinana*), dwarf downingia (*Downingia pusilla*), saline clover (*Trifolium hydrophilum*), Baker’s navarretia (*Navarretia leucocephala* ssp. *bakeri*), and hogwallow starfish (*Hesperervax caulescens*). As part of ongoing invasive species monitoring, Scott surveys the site to document new occurrences of invasive species, assess the effectiveness of past treatment on old occurrences, and direct new treatment. For grazing management, Scott assesses the site throughout the year and uses these regular observations as well as residual dry matter estimates to make grazing recommendations to the livestock manager. Finally, Scott helps monitor the inundation period of several seasonal wetlands at the site as part of habitat monitoring for special-status vernal pool crustaceans.

***Special-Status Plant Surveys and Sensitive Biological Community Assessment, Private Property, Montara, San Mateo County, California – Summer 2015***

Scott conducted an assessment of biological resources at a private property situated on coastal terrace and located within California Coastal

Commission jurisdiction. The assessment included surveying and mapping special-status plant species and evaluating the potential for occurrence of special-status plant species that were outside of their blooming periods at the time of the site visit. The assessment also including mapping the locations of any natural resources, such as wetlands and riparian vegetation, considered sensitive under federal, state, and local regulations including the Clean Water Act, the California Fish and Game Code, the California Environmental Quality Act (CEQA), and the County of San Mateo Local Coastal Program. Scott mapped populations of woodland strawberry (*Fragaria vesca*; considered sensitive under the San Mateo Local Coastal Program) as well as natural communities such as seasonal wetland and coastal terrace prairie.

***Special-Status Plant Surveys, Confidential Project Site, Kings County, California – Summer 2015***

Scott led a special-status plant survey at a 43-acre project site in the San Joaquin Valley in Kings County, California. The site is composed of alkaline soils and contains a number of vernal pools situated in alkaline grassland. During special-status plant surveys, thousands of individuals of special-status species were mapped, including Earlimart orache (*Atriplex cordulata* var. *erecticaulis*), lesser saltscare (*Atriplex minuscula*), and subtle orache (*Atriplex subtilis*). During the site visit, Scott also led a team in marking the boundaries of wetlands and special-status plant populations using wooden stakes.

***Special-Status Plant Surveying and Monitoring and Vegetation Mapping, Confidential Project Site, Santa Barbara County, California – Spring 2013-Winter 2015***

Scott has helped to conduct special-status plant surveys and map the vegetation of a 25,000-acre property in Santa Barbara County. Over the course of numerous visits, he has helped to cover the property on-foot, documenting occurrences of special-status plants and mapping plant communities to the alliance level. Scott has also helped to write annual biological resource reports for the site.

***Special-Status Plant Surveys and Delineation of Potential Jurisdictional Aquatic Features, Hawthorne Mill Property, Solano County, California – Spring 2014, Spring 2015***

The Hawthorne Mill property is a grazed grassland landscape that contains a network of vernal pools and is proposed to become a mixed-use development and conservation area. As part of a resource assessment in 2014, Scott conducted a floristic survey of part of the property and mapped occurrences of the federal-endangered Contra Costa goldfields (*Lasthenia conjugens*). In 2015, Scott assisted with the delineation of potentially jurisdictional wetland and non-wetland waters features at the site.

***Special-Status Plant Surveys, Aquatic Feature Assessment, and Regulatory Permit Application, Proposed Tembo Preserve, Tehama County, California – Fall 2013-Summer 2015***

The Tembo Preserve is a proposed elephant preserve at a 5,000-acre site in rural Tehama County. Habitats at the project site include oak woodland, non-native annual grassland, vernal pools, and episodic drainages. Scott has led multiple field efforts to survey for special-status plant species and map potential federal and state jurisdictional wetlands and non-wetland waters throughout the site. During special-status plant surveys, he documented an unknown population of big-scale balsamroot (*Balsamorhiza macrolepis*). Scott has been the lead author on CEQA-level biological resource assessment documents and has provided federal and state permitting support by writing and compiling the applications for the Army Corps of Engineers 404 Department of the Army permit and the State of California Regional Water Quality Control Board Section 401 Water Quality Certification.

***Special-Status Plant Surveys, Keller Canyon Landfill, Unincorporated Contra Costa County, California – Summer 2013***

The Keller Canyon Landfill is located in the hills near Pittsburg, California. The company was seeking to expand its area of operation, and Scott worked with a team of biologists to survey for summer-blooming special-status plants in disturbed and undisturbed grassland in and above the active landfill.

***Special-Status Plant Surveys, Antonio Mountain Ranch Conservation and Mitigation Bank-proposed, Roseville, Placer County, California – Spring 2013***

The Antonio Mountain Ranch Bank is a proposed conservation and mitigation bank for wildlife and wetlands. Scott conducted special-status plant species surveys and vegetation mapping. The 800-acre ranch supports extensive vernal pool complexes within non-native annual grasslands, perennial marsh and perennial stream habitats. Scott conducted surveys throughout the site for several special-status species that occur in vernal pool and grassland habitat.

***Special-Status Plant Surveying and Monitoring and Vegetation Mapping, Confidential Project Site, Santa Barbara County, California – Spring 2013-Winter 2015***

Scott has helped to conduct special-status plant surveys and map the vegetation of a 25,000-acre property in Santa Barbara County. Over the course of numerous visits, he has helped to cover the property on-foot, documenting occurrences of special-status plants and mapping plant communities to the alliance level. Scott has also helped to write annual biological resource reports for the site.

***Special-Status Plant Surveys, Pacific Commons Preserve Biological Monitoring, Alameda County, California – Summer 2013***

The Pacific Commons Preserve is a 444-acre preserve encompassing preservation of existing South Bay vernal pool habitat, creation of seasonal wetlands and vernal pools which host several species of special status plants and wildlife, and maintenance of interstitial upland grasslands. Scott worked with U.S. Fish and Wildlife Service staff to conduct annual monitoring of two special-status plant species: San Joaquin spearscale and Congdon's tarplant (*Centromadia parryi* ssp. *congdonii*).

***Special-Status Plant and Noxious Weed Surveys, Proposed Ramelli-Hall Grazing Allotment, Plumas County, California – Summer 2013***

WRA was contracted by Plumas Corporation to survey over 13,000 acres of Sierra meadow, scrub, and mixed conifer stands for special-status plant species as part of a proposed grazing allotment in Plumas National Forest. Scott helped to conduct and report the findings of protocol-level surveys for special-status plant species, sensitive vegetation/aquatic communities, and noxious weeds. During the surveys, thousands of individuals of three Forest Service Sensitive species were mapped in the various project areas. The surveys culminated in the drafting of a written report on-file with Plumas Corporation and Plumas National Forest.

***Special-Status Plant Surveys, Fen and Wet Meadow Boundary Mapping, Vegetation Mapping, and Vegetation Sampling, San Bernardino and Plumas National Forests, California – Summer 2012***

While working for the California Native Plant Society, Scott helped to assess the location and condition of fens and wet meadows in the mountains of the San Bernardino and Plumas National Forests. The assessment included fen and wet meadow boundary determinations, maps of dominant vegetation types, and surveys for special-status plants. In addition, Scott helped to sample vegetation types using the releve method.

***Vegetation Community Mapping, Desert Renewable Energy Conservation Plan Area, Riverside County, California – Spring-Fall 2012***

The California Energy Commission developed the Desert Renewable Energy Conservation Plan as part of a multi-agency collaboration with the goal of providing effective protection of natural resources while allowing for responsible renewable energy development in the Sonoran and Mojave Desert regions of California. While working for the California Native Plant Society, Scott participated in fine-scale vegetation community mapping and made incidental rare plant observations in the Sonoran Desert in Riverside County. He drove and hiked throughout the region to verify vegetation communities that had been preliminarily mapped using aerial imagery signatures. Vegetation community mapping followed the Federal Geographic Data Committee and National Vegetation Classification Standards. In addition, incidental special-status plant occurrences observed during vegetation mapping were documented.

***Vegetation Community Mapping, Carrizo Plain National Monument, Kern and San Luis Obispo Counties, California – Spring-Summer 2012***

The Bureau of Land Management (BLM) manages the approximately 250,000-acre Carrizo Plains National Monument, which is one of the few large, primarily undeveloped tracts of land remaining in California's San Joaquin Valley. To develop a baseline of knowledge to inform future management decisions, the BLM sought to develop a fine-scale vegetation community map for the entire Monument. While working for the California Native Plant Society, Scott drove and hiked throughout all parts of the Monument to verify vegetation communities that had been preliminarily mapped using aerial imagery signatures. Vegetation community mapping followed the Federal Geographic Data Committee and National Vegetation Classification Standards. In addition, incidental special-status plant occurrences observed during vegetation mapping were documented.

***Special-Status Plant Surveys, Post-Fire Assessment and Monitoring, Native Plant Seed Collection, Invasive Plant Species Management, Restoration Planting, Western Nevada and Eastern California – Winter-Fall 2011***

The Carson City District of the BLM administers approximately 4,800,000 acres of federal public land in eleven counties in western Nevada and eastern California. The District is composed of basin-and-range topography, and plant communities include salt desert scrub, sagebrush shrubland, pinyon-juniper woodland, and alpine meadows. In support of the resource management objectives of the District's botany department, Scott drove and hiked throughout the District to survey and map special-status plant species, assess and monitor recently burned areas, collect native plant seed, map and treat invasive plant species, and install restoration plantings. During special-status plant surveys, Scott helped document thousands of individuals of special-status species, including Williams' combleaf (*Polycytenium williamsiae*), altered andesite buckwheat (*Eriogonum robustum*), Carson Valley monkeyflower (*Erythranthe carsonensis*), Webber ivesia (*Ivesia webberi*), and Churchill narrows buckwheat (*Eriogonum diatomaceum*).



**CHRIS GURNEY, MS**  
Senior Associate

[gurney@wra-ca.com](mailto:gurney@wra-ca.com)

o: 415.524.7295

c: 805.407.5747

*Years of Experience:* 4

**Education**

M.S. Rangeland Management,  
University of California, Berkeley,  
2012

B.A. Environmental Science,  
Claremont McKenna College, 2009

**Certifications**

California Rapid Assessment  
Methodology (CRAM) Practitioner,  
2015

**Specialized Training**

Endangered Species Regulation, UC  
Davis Extension, 2013

California Native Grasses, California  
Native Grassland Association, 2013

Vegetation Mapping, California  
Native Plant Society, 2013

CEQA Mitigation Measures, UC  
Davis Extension, 2012

Basic Wetland Delineation, Wetland  
Training Institute, 2012

**Publications**

Restoration of Native Plants Is  
Reduced by Rodent-Caused Soil  
Disturbance and Seed Removal,  
Rangeland Ecology and  
Management, 2015

Chris holds a MS in Rangeland Management from UC Berkeley where he was a Graduate Research Fellow for the U.S. National Science Foundation. He has broad training and research experience in the fields of ecology, conservation biology, and environmental science. Chris is an expert in California plant and wetland ecology and has extensive experience throughout the state, particularly in the San Francisco Bay Area and Central Coast regions.

As a consultant, Chris specializes in wetland delineation, rare plant surveys, regulatory permitting, biological resource assessment, and analyzing environmental impacts under CEQA/NEPA. He has worked on a variety of projects in both the public and private sectors, including parks and open space projects, residential and commercial developments, transportation and infrastructure projects, and utility-scale renewable energy developments. Chris has experience working directly with environmental regulatory agency staff including the U.S. Army Corps of Engineers (Corps), the Regional Water Quality Control Board (RWQCB), and the California Department of Fish and Wildlife (CDFW).

**Representative Projects**

***Oak Knoll Development Project, Oakland, Alameda County, California***

SunCal is proposing to develop the approximately 200-acre former Naval Hospital site with nearly 1000 housing units as well as a retail center, a community center, and more than 60 acres of open space. The project also involves 5,000 linear feet of creek restoration, including 1,000 linear feet of creek daylighting. Chris is the Project Manager for WRA and oversees all of the biological and regulatory permitting work. The project involves numerous components including a biological resources assessment, wetland delineation, rare plant survey, tree survey, protocol-level wildlife survey, creek restoration plan, and regulatory permitting.

***California Flats Solar Project, Monterey and San Luis Obispo Counties, California***

The proposed Project entails development of an approximately 3000-acre solar photovoltaic energy generation facility in Central California. Chris conducted a wetland delineation and rare plant survey on both the Project site and potential conservation lands. He helped to develop new data collection protocols using iPads and managed data collection for over 10,000 acres of surveys. He was the primary author of several technical reports for the Project and analyzed rare plant impacts under CEQA.

***Ballona Wetlands Restoration Project, Los Angeles, Los Angeles County, California***

The California Coastal Conservancy, in partnership with the California Department of Fish and Wildlife, and the Santa Monica Bay Foundation has proposed a 600-acre open space and tidal wetland restoration project. Chris is the Project Manager for WRA and oversaw the preparation of the Biological Resources Section of the joint Environmental Impact Report/Environmental Impact Statement (EIR/EIS). Chris is also managing regulatory permitting for the project.



***Pilarcitos Quarry Expansion Project, San Mateo County, California***

The Pilarcitos Quarry is proposing an expansion into 99 acres of land adjacent to the existing operations area. The quarry property supports California red-legged frog and several other sensitive species as well as jurisdictional wetland and stream habitats. Chris is managing the regulatory permitting and mitigation plan for this project. The project will eventually result in the daylighting of over 1500 linear feet of Nuff Creek and will permanently conserve nearly 500 acres of habitat for California red-legged frog under a conservation easement.

***Oakland Army Base Redevelopment Project, Oakland, Alameda County, California***

The City of Oakland, in partnership with the Port of Oakland and the California Capital Investment Group, proposes to redevelop approximately 360 acres of land formerly occupied by the Oakland Army Base at a total cost of more than \$1 billion. Chris coordinated with regulatory agencies and prepared permit applications for the U.S. Army Corps of Engineers, the Regional Water Quality Control Board, and the Bay Conservation and Development Commission.

***Moorland Neighborhood Park, Sonoma County, California***

This project involves the development of a memorial park for Andy Lopez, the 13-year-old boy who was shot and killed on the site by a Sonoma County sheriff's deputy in 2013. The park, proposed by Sonoma County Regional Parks, is intended to provide much needed recreational space to an underserved community. Chris managed the biological resources assessment, wetland delineation, and regulatory permitting for this project, which is located in the ecologically sensitive Santa Rosa Plain. Biological constraints on the project site include jurisdictional wetlands, suitable habitat for listed plant species, and suitable habitat for California tiger salamander.

***Upper Llagas Creek Stormwater Improvements Project, Santa Clara County, California***

The Santa Clara Valley Water District proposed to improve storm water management and reduce the risk of flooding for residents in the vicinity of Upper Llagas Creek in south Santa Clara County. The Project entails substantial improvements (e.g. dredging and realignment) to multiple reaches of Upper Llagas Creek. Chris conducted a wetland delineation and prepared a wetland delineation report for several reaches of Upper Llagas Creek totaling more than 14 linear miles.

***Upper Penitencia Creek, Santa Clara County, California***

This project was a partnership between the Santa Clara Valley Water District and the Santa Clara Valley Open Space Authority. The project involved the acquisition and protection of a 222-acre property adjacent to Alum Rock Park and Sierra Vista Open Space Preserve. The property will eventually be open to the public and managed as an open space preserve. Chris authored a Long-term Management Plan for the property that will help ensure the property continues to function as high-quality habitat for threatened and endangered species.

***Moller Ranch Residential Development, Dublin, Alameda County California***

The proposed Project involves the development of 381 single-family residential homes, a neighborhood park, staging areas and trails, transportation and utilities infrastructures within approximately 93 acres of a 182-acre parcel. Chris prepared a complete set of regulatory permit applications including a Section 404 Individual Permit and Alternative Analysis for the U.S. Army Corps of Engineers.

***Alameda Point Outfalls Improvements Project, Alameda, Alameda County, California***

The City of Alameda proposes to remove and replace five outfalls and permanently remove two outfalls along the San Francisco Bay and Oakland Estuary shorelines. The Project would support improved storm water management infrastructure for the larger Alameda Point Redevelopment Project which will eventually redevelop more than 1,400 acres on Alameda Point. Chris prepared regulatory permit applications for the U.S. Army Corps

of Engineers, the Regional Water Quality Control Board, and the Bay Conservation and Development Commission.

**Various Caltrans Projects, San Francisco Bay Area, California**

Chris has prepared Natural Environment Studies (NES), regulatory permit applications, and wetland delineations for numerous Caltrans projects throughout the greater San Francisco Bay Area including the I-80/I-680/SR-12 Interchange Project (Solano County), the Redwood Shores Lagoon Bridge Replacement Project (San Mateo County), the Anzar Road Bridge Replacement Project (San Benito County), the SR-237 Express Lanes Project (Santa Clara County), the Stevens Canyon Road Bridge Replacement Project (Santa Clara County), and the I-80 Express Lanes Project (Solano County).



**AMANDA MCCARTHY,**  
**PhD, PWS**  
 Principal, COO

[mccarthy@wra-ca.com](mailto:mccarthy@wra-ca.com)  
 o: 415.454.8868 x1170

**Years of Experience:** 11

**Education**

Ph.D. Plant Biology, University of California, Davis, 2005

B.S. Environmental Biology and Botany, Humboldt State University, 2000

**Professional Affiliations/  
 Certifications**

Certified Professional Wetland Scientist (#2156)

California Native Plant Society

Southern California Botanists

Northern California Botanists

California Lichen Society

**Special Recognitions/  
 Publications**

Breen, A. N. & J. H. Richards. 2008. Seedling growth & nutrient content of two desert shrubs growing in amended soil. *Arid Land Research and Management* 22:46-61.

Breen, A. N. & J. H. Richards. 2008. Irrigation and fertilization effects on seed number, size, germination, and seedling growth: Implications for desert shrub establishment. *Oecologia* 157:13-19.

Dr. Amanda McCarthy specializes in regulatory permit preparation and compliance, wetland delineations, rare plant surveys, mapping and describing habitats, and analyzing environmental impacts under CEQA/NEPA. She has been involved in environmental review and restoration projects throughout California for both public and private groups. The majority of her experience is in desert ecosystems, but she also has extensive experience in vernal pools, riparian habitats, marshlands, and California annual grasslands. Amanda is formally trained in lichen identification, bryology, phycology, mycology, soils, hydrology, vegetation mapping, and environmental regulations.

Amanda has led the environmental entitlement process for numerous projects throughout California. Through her work negotiating with the regulatory agencies, she has developed a rapport with clients, environmental specialists, and various stakeholders to ensure project approval and ongoing compliance. She has extensive experience conducting formal wetland delineations for the U.S. Army Corps of Engineers and the California Coastal Commission and has completed the entire suite of regulatory permit applications for a number of projects, including nationwide and individual permits for the U.S. Army Corps of Engineers, water certification and waste discharge requirements from the Regional Water Quality Control Board, major permits and consistency determinations from the San Francisco Bay Conservation and Development Commission, streambed alteration agreements from the California Department of Fish & Game, construction permits from the California Coastal Commission, and encroachment permits from several local water districts.

**Representative Projects**

***Tehachapi Renewable Transmission Project EIR/EIS and Protocol-Level Rare Plant Surveys, Kern, Los Angeles, Orange, and Riverside Counties, California***

Southern California Edison proposed to construct 50 miles (80.5 kilometers) of transmission line and construct new access roads, towers, and electrical substations. The proposed route crosses numerous ecosystems, including desert, mountain, canyon, riparian, agricultural, and residential areas. This project included extensive background research, analysis of special-status species occurrences, review of general plans and Habitat Conservation Plans, and reconnaissance-level field surveys to describe and map existing habitat types. In addition, Amanda managed protocol-level, floristic plant surveys conducted from March through July. Amanda worked extensively with the Angeles National Forest, consultants, and planners in preparing portions of the biological portion of the environmental compliance documents including: existing conditions, regulatory framework, and cumulative impacts sections; complete plant species lists by impact area; and weed assessment and management plan. In addition, she worked on the delineation of Waters and Riparian Conservation Areas (RCA) for the project and developed the RCA Treatment Plan for the project.

***Oak Knoll Redevelopment Project Alameda County, California***

Amanda manages all of our ongoing work with SunCal on the redevelopment of the military hospital site. Working with SunCal, ESA, BKF Engineers, and other firms, WRA assisted with the Environmental Impact Report (EIR) portion of the California Environmental Quality Act (CEQA) review process. WRA conducted a range of biological surveys including nesting bird and bat surveys, rare plant surveys, and oak woodland surveys. Based on the information collected during these surveys, WRA prepared a wetland delineation report and agency permit applications for the restoration of 3,500 feet of Rifle Range Creek, including a California Department of Fish & Game Lake and Streambed Alteration Agreement and Clean Water Act Section 401 and Section 404 permits. WRA is currently preparing all of the regulatory permits for the redevelopment project, as well as tree mitigation plans, the Habitat Mitigation and Monitoring Plan, and City of Oakland Permits.

***Gaver Ranch Permitting Project Monterey County, California***

Amanda manages all of the permit compliance for the Gaver Ranch project, a strawberry farm outside of Castroville, California. The project has involved a complicated regulatory permitting approval process, with no federal nexus through the Corps, informal consultation with the USFWS, two SAAs and an ITP with the CDFW, restoration work, and ongoing maintenance activities in habitat of CRLF and potential habitat for CTS. Amanda manages the biological monitoring and permit compliance for the project.

***Sunrise Powerlink Project, San Diego and Imperial Counties, California***

Amanda managed the delineation of wetlands and waters (waters of the U.S. and waters of the State) for the Sunrise Powerlink project, a 200-mile transmission line between San Diego and the Imperial Valley. All of the federal and state waters impacts were successfully permitted for the transmission line. Permits included 135 U.S. Army Corps of Engineers Section 404 Nationwide permits, a California Department of Fish and Game Streambed Alteration Agreement, and a State Water Quality Control Board Section 401 Water Quality Certification. Currently, Amanda is managing all of the permit compliance conditions for the regulatory agencies with regards to waters. In addition, she is managing the implementation of the Habitat Mitigation and Monitoring Plans (HMMP) for the project.

***Moosa Creek Mitigation Bank, San Diego County, California***

Amanda is managing all of the entitlement for the proposed mitigation bank and working with the Interagency Review Team (IRT) to finalize the Bank Enabling Instrument (BEI). Amanda managed biologists, hydrologists, and the design team to meet the requirements of the 2008 mitigation rule and to satisfy the IRT. In addition to the draft prospectus, prospectus, response to public comment, and draft BEI, Amanda will manage all of the regulatory permitting and CEQA documentation for the project.

***Ballona Wetlands Ecological Reserve Restoration Project, Los Angeles County, California***

Amanda managed the delineation of wetlands and waters (waters of the U.S. and waters of the State) and protocol-level rare plant surveys for the Ballona Wetlands Ecological Reserve Restoration Project, an approximately 600-acre open space area slated for restoration to tidal wetland habitat. In addition, she is developing the Conceptual Resource Management Plan and Mitigation and Monitoring Plan for the project and is contributing to the EIR/EIS for the project.

***Brightsource Rio Mesa Solar Concentrating Project, Riverside County, California***

Amanda managed the delineation of wetlands and waters (waters of the U.S. and waters of the State) and peer review of previously conducted work for the proposed solar concentrating project outside of Blythe, California. Delineation of dry wash habitat, ordinary high water mark features, and desert woodland habitat was completed

for the project. Strategic planning for the regulatory permitting was also conducted, with the hopes of permitting the project quickly and efficiently. Brightsource abandoned the project before permitting was completed.

***Ardenwood Creek Restoration Project, Alameda County, California***

Amanda managed the delineation of wetlands and waters (waters of the U.S. and waters of the State), the Biological Assessment, the Biological Resource Assessment, all regulatory permitting, development of the HMMP and mitigation design, and public outreach for the restoration of the flood control channel. In addition, she worked with the stakeholders to develop a plan to remove biomass of cattail through grazing to avoid potential impacts to salt marsh harvest mouse.

***Coyote Creek Dredging Project, Marin County, California***

Amanda managed the delineation of wetlands and waters (waters of the U.S. and waters of the State), including Section 10 waters, the Biological Assessment, the Biological Resource Assessment, all regulatory permitting, development of the HMMP and mitigation design, and public outreach for the restoration of the flood control channel. In addition, she assisted in the development of the project description for CEQA and located staging areas and disposal areas for the dredge material.

***South Bay Salt Pond Restoration Project Regulatory Agency Permitting, Santa Clara, San Mateo, and Alameda Counties, California***

The 15,100-acre South Bay Salt Pond Restoration Project is the largest tidal wetland restoration ever planned on the West Coast. When complete, the restoration will convert thousands of former commercial salt ponds to a mix of tidal marsh, mudflat, managed pond, and other habitats. The project will also provide flood management and opportunities for wildlife-oriented public access and recreation. As a key member of the technical consultant team, Amanda prepared materials in support of the EIR/EIS and prepared and processed the regulatory and resource agency permits, including the Bay Conservation and Development Commission and the U.S. Army Corps of Engineers, and provided input on the Regional Water Control Board permit. In addition, she assisted with the preparation of the Biological Assessments for the U.S. Fish and Wildlife Service and the National Marine Fisheries Service. Amanda also assisted in the preparation of the technical support documents for the permit applications including the wetland delineation, environmental document, biological assessments, mitigation & monitoring plans, and adaptive management plans, and prepared the 404(b)(1) alternatives analysis. Restoration efforts are currently underway.

***Union City San Francisco Bay Trail Regulatory Agency Permitting, Alameda County, California***

East Bay Regional Parks, in cooperation with Caltrans, is proposing improvements for completion of the Union City section of the San Francisco Bay Trail. The project proposes the following improvements: trail surfacing and drainage improvements on existing flood control levees and unpaved maintenance roads, and protective fencing along a portion of the trail. Trail crossings proposed over two channels are anticipated to have temporary and permanent impacts to muted tidal, diked salt marsh, and aquatic habitat. For this project, Amanda completed all environmental documents, including a Natural Environment Study and Wetland Technical Assessment (formal wetland delineation), and assisted in the completion of the Biological Assessment. In addition, she prepared permit materials for a U.S. Army Corps of Engineers Section 404 Nationwide Permit, Regional Water Quality Control Board Section 401 Water Quality Certification, California Department of Fish and Game Streambed Alteration Agreement, and Bay Conservation and Development Commission Administrative Permit. Various technical studies are currently under review by Caltrans and permit processing is anticipated to commence in early 2010.

***State Route 1/Calera Parkway Improvement Project, San Mateo County, California***

The San Mateo County Transportation Authority, the City of Pacifica, and Caltrans are proposing an operational improvement on State Route 1/Calera Parkway in the City of Pacifica, San Mateo County, California. The proposed project occurs within the coastal zone and proposed improvements may impact wetlands and the federally listed San Francisco giant garter snake and California red-legged frog that are known to occur within the study area. Amanda contributed to the environmental studies (NES) and biological assessment and conducted the formal wetland delineation for the project that will be used in preparing application materials for a California Coastal Commission Coastal Development Permit, U.S. Army Corps of Engineers Section 404 permit, California Department of Fish and Game Streambed Alteration Agreement and Regional Water Quality Control Board Section 401 Water Quality Certification.

***Bodega Bay Coastal Prairie Trail Project, Sonoma County, California***

The Bodega Bay Coastal Prairie Trail Project is an approximately 1-mile long section of the Coastal Trail being constructed by Sonoma County Parks through an agreement with California State Parks. Amanda prepared all of the permit application materials for the U.S. Army Corps of Engineers Section 404 Nationwide Permit, the California Department of Fish and Game Streambed Alteration Agreement, and the Section 401 Water Quality Certification through the Regional Water Quality Control Board. Currently, Amanda is working with these waters regulatory agencies to receive project approval for impacts to waters as part of project implementation.



**SCOTT YARGER, BS**  
Biologist

[yarger@wra-ca.com](mailto:yarger@wra-ca.com)

Direct: 415.525.7549

Office: 415.454.8868 x1510

**Years of Experience:** 6

**Education**

BS, Conservation and Resource Studies, Minor in Forestry and Natural Resources, University of California, Berkeley, 2009

**Professional Affiliations/Certifications**

ISA Certified Arborist #WE-9300A

ISA Tree Risk Assessment Qualified

Western Chapter ISA Member

California Native Plant Society

**Specialized Training**

Forest Diseases Workshop, Jepson Herbarium, 2016

ISA Tree Risk Assessment Qualification Course, 2014

Sudden Oak Death Treatment Training Workshop, 2014

Rare Plant Survey Protocols Course CNPS, 2013

California red-legged frog (CRLF) Monitoring Workshop, 2012

Scott Yarger received his Bachelor of Science degree with High Distinction in Conservation and Resource Studies from University of California, Berkeley, where his studies focused on environmental policy and land management. His interdisciplinary background includes training in ecology, botany, conservation biology and environmental policy. His minor in Forestry and Natural Resources included field studies in forest ecology and management in the Sierra Nevada ecoregion.

Scott is an ISA Certified Arborist (#WE-9300A) and is Tree Risk Assessment Qualified (TRAQ). Prior to joining WRA, Scott worked for four and a half years as a consulting arborist contracted to Pacific Gas and Electric Company (PG&E). He has worked in a wide variety of habitats throughout northern and central California, and his experience includes tree inventory and health assessment of both native and ornamental species, tree risk assessment, vegetation mitigation and monitoring plans, and compliance with local, state and federal regulations.

At WRA, Scott's work includes arborist surveys and reports, tree appraisal, tree protection plans, vegetation monitoring and mitigation plans, biological resource assessment, rare plant surveys, wildlife surveys and monitoring, and environmental compliance and permitting to include municipal tree ordinance compliance and tree removal permits, California Surface Mining and Regulation Act (SMARA) compliance, U.S. Army Corps of Engineers (Corps) section 404 permits, Regional Water Quality Control Board (RWQCB) section 401 permits, U.S. Fish and Wildlife Service (USFWS) Biological Assessments, and California Department of Fish and Wildlife (CDFW) 1602 Lake and Streambed Alteration Agreements.

**Representative Projects**

**Oak Knoll Development Project, Oakland, Alameda County, California**

SunCal is proposing to develop the approximately 200-acre former Naval Hospital site with nearly 1000 housing units as well as a retail center, a community center, and more than 60 acres of open space. The project also involves 5,000 linear feet of creek restoration, including 1,000 linear feet of creek daylighting. WRA is the Project biological consultant, responsible for California Environmental Quality Act (CEQA) biological studies and regulatory permitting. Scott has contributed to field studies and report writing of the biological resources assessment, special-status plant survey, and tree survey to support the Environmental Impact Report (EIR) for the Project. Scott is the consulting arborist for the Project, and he led a team of arborists and biologists in conducting a comprehensive tree survey of the Project Area in order to comply with the City of Oakland Tree Protection Ordinance. The tree survey included an inventory and health assessment of approximately 7,000 within the Project site and surrounding areas potentially impacted by the Project. Scott prepared a tree survey report and tree removal mitigation plan as supporting documents for CEQA analysis. Scott has also prepared a protected tree removal permit and solicited bids for tree moving contractors on behalf of the Client.

***Marin Country Day School Creek Restoration Project, Corte Madera, California***

Scott conducted a tree survey report and prepared a tree preservation/protection plan in support of a voluntary creek restoration project at Marin Country Day School, in Corte Madera, California. Scott surveyed all protected trees within the Project Area as defined by the Town of Corte Madera Tree Ordinance, and prepared a tree preservation/protection plan which provided tree preservation recommendations and construction-related tree protection measures for trees selected for preservation.

***The Oaks Senior Assisted Living Facility Arborist Survey and Report, Marinwood, California***

Scott conducted a tree survey and report in support of a proposed senior assisted living facility in Marinwood, unincorporated Marin County, California. The survey identified all trees protected per the Marin County Tree Preservation Ordinance, in addition to riparian trees under the jurisdiction of CDFW under Section 1602 of the California Fish and Game Code. The tree survey report is a supporting document for a Marin County tree removal permit, and a CDFW Streambed Alteration Agreement permit application.

***2<sup>nd</sup> and Walpert Residential Development Arborist Survey and Tree Appraisal Report, Hayward, California***

Scott conducted a tree survey and report on a 16-acre proposed residential development site to inventory protected trees per the City of Hayward Tree Preservation Ordinance within and directly adjacent to the proposed Project Area. Scott's tree survey report included pertinent data on protected trees, including species, size, assessment of health, condition, structure, and recommended tree protection measures. The tree survey report serves as a supporting document for CEQA analysis. In response to additional City of Hayward requirements, Scott also conducted a tree appraisal of protected trees within the Project Area, in order to assist in setting mitigation requirements for loss of protected trees. The tree valuation followed the methods outlined in *Guide for Plant Appraisal, 9th Edition* (Council of Tree and Landscape Appraisers "CTLA" 2000).

***Mathilda Avenue Arborist Survey and Tree Appraisal Report, Sunnyvale, California***

Scott conducted an arborist survey and tree appraisal report on a 4-acre proposed commercial development project in Sunnyvale, California. The purpose of the survey was to inventory and appraise trees protected per the City of Sunnyvale Tree Preservation Ordinance. Scott's assessment included species, size, protection status, ratings on health, structure and general condition and valuation of the trees surveyed. The tree valuation will follow the methods outlined in *Guide for Plant Appraisal, 9th Edition* (CTLA 2000).

***Santa Margarita Quarry Expansion Project, Oak Woodland Mitigation Plan Santa Margarita, San Luis Obispo County, California***

Hanson Aggregates is applying for a modification to an existing Conditional Use Permit (CUP) and seeking approval for a Reclamation Plan Amendment (RPA) to expand the existing operations of the Santa Margarita Quarry, located approximately three miles northeast of the community of Santa Margarita. The Quarry is a hard-rock aggregate mining facility located in an unincorporated area of San Luis Obispo County, California. WRA has been involved in the Project as the biological consultant since 2007. Scott conducted an oak woodland health and condition assessment on adjacent parcels owned by the Quarry and prepared an oak woodland mitigation plan to identify suitable coast live oak woodlands for preservation in compliance with San Luis Obispo County compensatory mitigation requirements pursuant to the CEQA. Scott also prepared regulatory permit applications for Corps Section 404 Nationwide Permit 44, RWQCB Section 401 Water Quality Certification, and CFGC Section 1602 Streambed Alteration Agreement for the proposed Project.





## about

Francisco Martin is an Associate with Fehr & Peers. Francisco has over nine years of work experience. He has served as Project Manager or Project Engineer/Planner on numerous transportation planning projects, including impact analysis (TIA) studies, environmental impact reports (EIR), specific plans and transportation demand management plans. Typical project tasks have included baseline conditions analysis, trip generation and distribution, traffic forecasting, and project impacts and mitigations. Francisco has extensive experience with traffic operations analysis, including performance measure evaluation, needs assessment and evaluation of transportation infrastructure improvements. Francisco also has substantial experience with multimodal planning projects that apply complete street concepts, balancing the infrastructure needs among the major travel modes.

## education

Bachelor of Science in Civil Engineering, University of California, Berkeley, 2007

## registrations and affiliations

Licensed Civil Engineer, State of California (# C 79898)  
Institute of Transportation Engineers: Member

## expertise

- Transportation and Land Use Planning
- Traffic Impact Analysis and Environmental Impact Reports
- Multimodal and Complete Streets Planning
- Mixed Use and Transit Oriented Development
- Transportation Demand Management
- Site Plan Review
- General Plans and Specific Plans
- Traffic Operations Analysis
- Travel Demand Forecasting
- Parking Studies

## project experience

### *Transportation Impact Studies*

Completed transportation engineering analysis and environmental impact review, including CEQA analysis for new and reuse developments, analysis of existing conditions, project trip generation and distribution, site access, impacts and mitigations on automobile, bicycle, pedestrian, and transit access and circulation. Studies include:

- University Village at San Pablo, Albany
- Safeway Stores, Berkeley, Oakland and Pleasant Hill
- Cal Aquatics Center EIR, Berkeley
- Candlestick Point/Hunters Point EIR, San Francisco
- US 101/Holly Street Interchange PA/ED, San Carlos
- Eden Medical Center, Castro Valley

### *Transportation Planning*

Served as Project Manager or Project Engineer on various transportation planning projects, including analysis of vehicular, pedestrian, bicycle, and transit circulation. Studies include:

- Alameda Countywide Multimodal Arterial Plan
- Ashland-Cherryland Business District Specific Plan and TDM Plan, Alameda County
- Solano Fairgrounds Specific Plan, Vallejo
- Fairfield Train Station Area Specific Plan
- City of Tracy Transportation Master Plan
- Stanford University Transportation Planning

### *Parking Studies*

Prepared parking studies including analysis of existing parking conditions and estimation of future parking demand for specific developments and area-wide. Examples include:

- Lawrence Berkeley National Laboratory
- Alta Bates Medical Center, Berkeley
- Washington Hospital Parking Study, Fremont
- Downtown Richmond Parking Study
- University of California, Berkeley
- John Muir Medical Center, Concord





## about

Sam is a registered Professional Civil Engineer and Traffic Engineer in California, and Professional Traffic Operations Engineer with 18 years of experience in Fehr & Peers' Oakland office. Sam has extensive experience managing a variety of transportation planning and traffic engineering projects, including integrated land use/transportation planning, transportation impact studies, traffic fee studies, traffic calming plans, parking studies, site plan review, and traffic operations analysis. Sam's particular areas of expertise include environmental review under CEQA, and development site traffic engineering review.

## education

Master of Science in Civil Engineering, University of California, Berkeley, 1997

Bachelor of Science in Civil Engineering, University of California, Berkeley, 1995

## affiliations

Institute of Transportation Engineers: Associate

## registrations

Licensed Civil Engineer, State of California (#64006)

Licensed Traffic Engineer, State of California (#2313)

Licensed Professional Traffic Operations Engineer (#1639)

## expertise

- Traffic Engineering
- Transportation and Land Use Planning
- Traffic Impact Analysis and Environmental Reports

- Transportation Demand Management (TDM) Plans
- Institutional Planning
- Parking Studies
- Traffic Calming
- Parking Studies
- Site Access and Circulation
- General and Area Wide Specific Plans

## publications & presentations

*Evaluating Interface Standards for the Public Transit Industry*, Transportation Research Record No. 1618, 1998

*Transportation Impact Studies – Analysis of Alternative Transportation Modes*, 1999 ITE Annual Meeting and Exhibit

*Measuring Costs and Benefits of Reducing Congestion in a Growing City: Striking a Balance*, 2004 ITE Annual Meeting and Exhibit

*Methodology for Trip Generation Estimation for a Large Urban University*, 2005 ITE District 6 Annual Meeting

## honors and awards

*Redwood City General Plan - APA Northern California Comprehensive Planning, Small Jurisdiction*, 2012

*MacArthur BART Access Feasibility Plan – California APA Project of Merit*, 2008

## project experience

### **Pittsburg/Bay Point BART Master Plan (Pittsburg, CA)**

Fehr & Peers prepared the transportation sections of the Specific Plan and EIR, and a stand-alone Access Plan which would develop the current surface parking and vacant land surrounding the BART station as a dense, mixed-use development.



2201 Broadway  
Suite 400  
Oakland, CA 94612  
510.834.3200

## **Coliseum Area Specific Plan and EIR (Oakland, CA)**

Fehr & Peers was part of the multi-disciplinary team that prepared the Specific Plan and environmental documents for the proposed Coliseum Area project, which would replace the current stadia with up to three new stadia and accommodate new sports-related entertainment district, a new mixed-use residential neighborhood, and new research and development.

## **General Plan Update and EIR (Redwood City, CA)**

Fehr & Peers prepared the Circulation Element update, addressing all travel modes, including pedestrians, bicycles, buses, trains, automobiles, and trucks and completed the environmental analysis.

## **Children's Hospital and Research Center Oakland EIR and TDM (Oakland, CA)**

Fehr & Peers prepared the transportation chapter of the EIR for the project which included multi-modal street improvements to better serve the expanded campus, and prepared a robust TDM plan to reduce the traffic and parking demand generated by the project.

## **Safeway Redevelopment Project Broadway at Pleasant Valley Avenue EIR (Oakland, CA)**

Fehr & Peers prepared the transportation chapter of the EIR for the shopping center expansion project and provided input on the access and circulation system within and surrounding the project site.

## **Kaiser Medical Center Master Plan and EIR (Oakland, CA)**

Fehr & Peers provided a variety of services for a new one-million square foot medical center, including the multi-modal transportation system serving the site, preparing the transportation section of the EIR, and design support during project construction.

## **Kaiser Medical Center Master Plan (San Leandro, CA)**

Fehr & Peers worked with the project team to design the transportation system and estimate parking demand at different phases of development for a new medical center.

## **Oakland Transportation Impact Fee Nexus Analysis (Oakland, CA)**

Fehr & Peers was part of the team that prepared the first citywide fee for new developments to fund the multi-modal transportation infrastructure needed to serve the growing population and the changing travel needs of the City.

## **Center Street Garage Reconstruction (Berkeley, CA)**

Fehr & Peers estimated future parking demand in downtown Berkeley to determine the size of the proposed garage, prepared the transportation section of the environmental document, and worked with City to formulate strategies to mitigate the parking impacts during construction.

## **South Richmond Specific Plan EIR (Richmond, CA)**

Fehr & Peers prepared the transportation chapter of the EIR for the proposed specific plan which would accommodate up to 5,700 residential units and over six million square feet of non-residential development. As part of the project, Fehr & Peers quantified the effects of various multi-modal improvements on project automobile trip generation and VMT.

## **General Plan Update EIR (Albany, CA)**

Fehr & Peers prepared completed the transportation section of the environmental document which analyzed the impacts of the development envisioned and policies proposed by the General Plan on various aspects of the transportation system, including estimation of VMT.



CAREY & CO. | A TreanorHL Company

**R É S U M É**

**ELIZABETH GRAUX**  
**Architectural**  
**Historian**  
**Intern Architect**

*Master of Arts*  
*Historic*  
*Preservation*  
*Certificate in*  
*Museum Studies*  
*University of*  
*Delaware*

*Bachelor of*  
*Architecture*  
*California State*  
*Polytechnic*  
*University,*  
*Pomona*

*Meets the*  
*Secretary of the*  
*Interior's*  
*Professional*  
*Standards for*  
*Historic*  
*Architecture and*  
*Architectural*  
*History*

Elizabeth Graux is experienced in both historic preservation and architectural practice. At the University of Delaware's Center for Historic Architecture, she documented historic properties including eleven structures with historic easements for the Maryland Historical Trust. Ms. Graux worked and volunteered for the National Park Service in Yosemite where she prepared a Historic Structure Report for the Rangers' Club. For Curry Village, she prepared a condition assessment of forty-eight cabins within the park, documented structures through measured drawings and made recommendations for rehabilitation per guidelines in *The Secretary of the Interior's Standards for the Treatment of Historic Properties*. The Park Service and the concessionaire are using her thesis as a resource for the HSR that is currently underway for the cabins.

■ **PROFESSIONAL EXPERIENCE**

**CAREY & CO. INC., San Francisco, CA**

Post & San Pedro Tower EIR, San Jose  
Park View Towers, Revised Project EIR, San Jose  
Fire Station 5 Replacement Project EIR, San Francisco  
Wurster House HRER and Wurster-designed Buildings Survey, Sausalito  
2550 Green Street HRER, San Francisco, CA  
500 Jefferson Street HRER, San Francisco, CA  
Grant Ranch Historic Structures Report, San Jose, CA  
902 Villa Street Mitigation Report, Mountain View, CA  
1 Spruce Street HRER, San Francisco, CA  
SFPUC Groundwater Storage and Recovery Project EIR, San Francisco Peninsula  
PJJK Federal Building & Courthouse, National Register Study, Honolulu  
Central Subway HABS documentation, San Francisco  
Constant Winery National Register Nomination, Calistoga, CA  
572 Seventh Street California Register Nomination, San Francisco, CA  
San Luis Obispo Chinatown HABS Documentation, San Luis Obispo, CA

**Dwight Gregory Architecture and Design, Santa Barbara, CA**

Assisted in the preparation of construction documents for a variety of residential, commercial and museum projects.

**University of Delaware, Newark, DE**

Graduate Assistant for survey and documentation of over 30 historic structures throughout the Mid-Atlantic region

**Yosemite National Park (History, Architecture & Landscape Branch)**

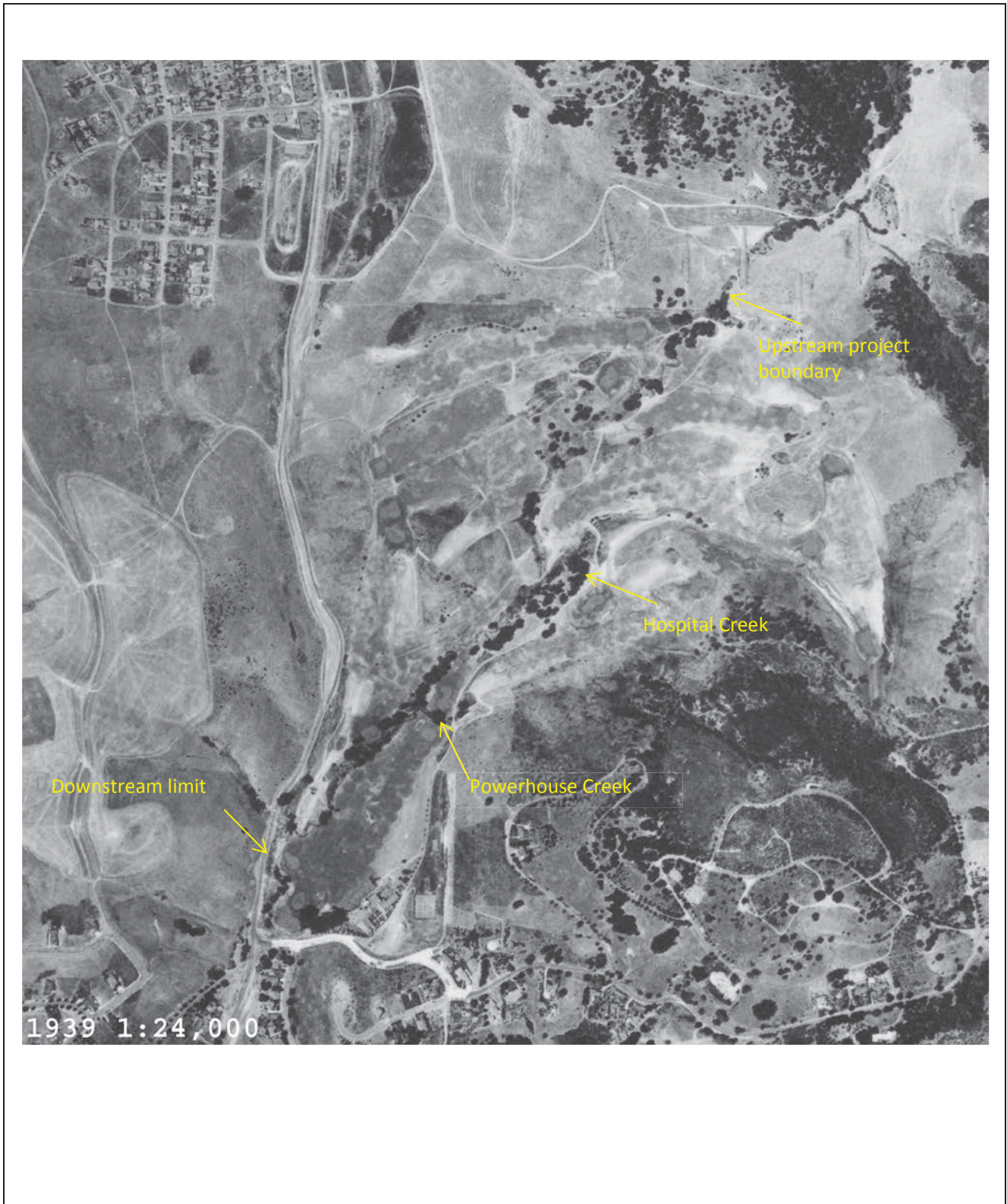
Intern. Assisted in the preparation of a Historic Structures Report for the nationally significant Rangers' Club.

**Santa Barbara City College, Santa Barbara, CA**

Assistant instructor in an AutoCad class

# **Appendix M**

## Historic Open Grasslands



Oak Knoll . D140419  
**Figure 2**  
1939 Aerial photo

**Appendix N**  
Updated Vehicle Miles  
Traveled (VMT) Calculations  
(February 2017)

**Daily and Annual Project VMT  
Oak Knoll Mixed Use Community Project  
Oakland, California**

**Annual Project VMT without TDM**

Trip Type	Project Daily One-way Vehicle Trips, no TDM				Days Per Year	Daily One-way Vehicle Trips	Weighted Trip Length [mile/trip]	Miles/Day	Annual VMT
	Condo/Townhouse	Single Family Housing	Regional Shopping Center	Internal Trips		Total			
Weekday	2,927	3,053	5,270	1,110	261	12,360	5.7	69,924	18,250,287
Saturday	2,860	3,180	7,190	1,300	52	14,530	5.4	79,033	4,109,708
Sunday	2,440	2,760	4,850	990	52	11,040	5.6	62,007	3,224,385
					<b>365</b>	--	<b>5.6</b>	--	<b>25,584,380</b>

**Daily Project VMT without TDM**

Trip Type	Project Daily VMT by Land Use, without TDM				Total Daily VMT, without TDM
	Condo/Townhouse	Single Family Housing	Regional Shopping Center	Internal Trips	
Weekday	22,463	23,430	23,476	555	69,924
Saturday	21,949	24,405	32,029	650	79,033
Sunday	18,726	21,182	21,605	495	62,007

**Annual Project VMT with TDM**

Trip Type	Project Daily One-way Vehicle Trips, with TDM				Days Per Year	Daily One-way Vehicle Trips	Weighted Trip Length [mile/trip]	Miles/Day	Miles/Day
	Condo/Townhouse	Single Family Housing	Regional Shopping Center	Internal Trips		Total			
Weekday with TDM	2,537	2,653	4,580	1,110	261	10,880	5.6	60,788	15,865,645
Saturday with TDM	2,490	2,770	6,240	1,300	52	12,800	5.4	68,815	3,578,371
Sunday with TDM	2,120	2,400	4,210	990	52	9,720	5.5	53,938	2,804,765
					<b>365</b>	--	<b>5.6</b>	--	<b>22,248,781</b>

**Daily Project VMT with TDM**

Trip Type	Project Daily VMT by Land Use, with TDM				Total Daily VMT, with TDM
	Condo/Townhouse	Single Family Housing	Regional Shopping Center	Internal Trips	
Weekday	19,470	20,360	20,402	555	60,788
Saturday	19,110	21,258	27,797	650	68,815
Sunday	16,270	18,419	18,754	495	53,938



# **Appendix O**

## Updated GHG Reduction Plan (GGRP) (December 2016)



Prepared for:  
**Oak Knoll Venture Acquisitions, LLP**

Prepared By:  
**Ramboll Environ US Corporation**  
**San Francisco, California**

Date  
**December 2016**

Project Number  
**03-39329A**

# **OAK KNOLL MIXED USE PROJECT**

## **GREENHOUSE GAS REDUCTION PLAN**

## CONTENTS

<b>1.</b>	<b>INTRODUCTION</b>	<b>1</b>
1.1	Project Description and Overview	1
1.2	SCA GHG-1	2
<b>2.</b>	<b>SUMMARY OF GHG EMISSIONS</b>	<b>3</b>
2.1	Summary of Existing Conditions GHG Emissions	3
2.2	Proposed One-time Project GHG Emissions	3
2.2.1	Summary of Construction GHG Emissions	3
2.2.2	Summary of Land-Use Change and Vegetation GHG Emissions	3
2.3	Proposed Ongoing Project GHG Emissions	4
2.3.1	Methodology for Project Emissions Inventories	4
2.3.1.1	Area Sources	4
2.3.1.2	Purchased Electricity Not Related to Water Use	5
2.3.1.3	Natural Gas	5
2.3.1.4	Water Use, Including Purchased Electricity	5
2.3.1.5	Waste	6
2.3.1.6	Mobile Sources	6
2.4	Current State and Local Requirements that Reduce GHG Emissions	6
2.4.1	State and Local Requirements Other Than the Transportation Demand Management (TDM)	6
2.4.2	TDM	7
2.4.3	Phasing	7
2.4.4	Comparison of 2005 BAU and 2024 Project Emissions Inventories	9
2.4.5	GHG Emissions Per Service Population	10
<b>3.</b>	<b>PROPOSED GHG REDUCTION MEASURES</b>	<b>11</b>
<b>4.</b>	<b>IMPLEMENTATION AND ANNUAL REPORTING</b>	<b>14</b>
4.1	Plans for Future Reporting	14
<b>5.</b>	<b>SUMMARY</b>	<b>15</b>

## TABLES

Table 1:	Project Land Uses
Table 2:	Operational Emissions by Phase
Table 3:	Summary of Full Buildout 2005 BAU Project and 2024 Project Greenhouse Gas Emissions (MT/yr CO <sub>2</sub> e)
Table 4:	Summary of Mitigation Measures That Would Achieve The City's SCA GHG-1 Requirements

## **APPENDICES**

Appendix A: Supporting Calculations

## ACRONYMS AND ABBREVIATIONS

ARB:	[California] Air Resources Board
BAAQMD:	Bay Area Quality Management District
BAU:	business as usual
Caltrans:	California Department of Transportation
CAPCOA:	California Air Pollution Control Officers Association
CEQA:	California Environmental Quality Act
CH <sub>4</sub> :	methane
CHTS:	California Household Travel Survey
CO <sub>2</sub> :	Carbon Dioxide
CO <sub>2</sub> e:	Carbon Dioxide Equivalent
CPUC:	California Public Utilities Commission
DEIR:	Draft Environmental Impact Report
EBMUD:	East Bay Municipal Utility District
ECAP:	Energy and Climate Action Plan
EIR:	Environmental Impact Report
ESA:	Environmental Science Associates
GGRP:	Greenhouse Gas Reduction Plan
GHG:	Greenhouse Gas
MT:	metric ton
MT/yr:	metric ton per year
N <sub>2</sub> O:	nitrous oxide
NMCO:	Naval Medical Center Oakland
PG&E:	Pacific Gas and Electric Company
SCA:	Standard Condition of Approval
SP:	service population
TDM:	Transportation Demand Management
VMT:	vehicle miles traveled

# 1. INTRODUCTION

The City of Oakland, California, requires a greenhouse gas (GHG) Reduction Plan (GGRP) for the Oak Knoll Mixed Use Project (“Oak Knoll Project”), as a standard condition of approval (SCA). The Oak Knoll Project is pursuing environmental entitlements under the California Environmental Quality Act (CEQA), with the City of Oakland as the lead agency. Under SCA GHG-1, the City of Oakland requires a GGRP that requires the Oak Knoll Project to increase energy efficiency and reduce GHG emissions below at least one of the Bay Area Quality Management District’s (BAAQMD’s) CEQA Thresholds of Significance and 36% below a 2005 “Business as Usual” (BAU) scenario, as defined in the City’s Energy and Climate Action Plan (ECAP).

## 1.1 Project Description and Overview

The Oak Knoll Project site consists of approximately 165 acres of the 183-acre former Oak Knoll Naval Medical Center Oakland (NMCO) property, approximately 15 acres of an adjacent property (known as the “Hardenstine parcel”), approximately 8 acres of City-owned property, and approximately 2.9 acres of East Bay Municipal Utility District (EBMUD)-owned and other property, for a site with a total size of approximately 190.9 acres. The Project site is bounded by Mountain Boulevard/Interstate 580 (I-580) to the west, Keller Avenue to the north and east, and Sequoyah Road to the south.

The Project site consists of former U.S. Navy land, previously the location of a medical facility, as well as the adjacent, undeveloped Hardenstine parcel. The NMCO facility was decommissioned in 1996, medical and related facilities were subsequently demolished, and the site has been largely unoccupied since that time. For this reason, no existing conditions are considered in this analysis.

The Oak Knoll Project would create a mixed-use development consisting of residential neighborhoods, commercial development, and open space and recreational facilities. Table 1 shows the breakdown of proposed land uses.

<b>Table 1. Project Land Uses</b>			
<b>Land Use</b>	<b>Size</b>	<b>Units</b>	<b>Population</b>
Townhouse	572	Dwelling Units	1,368
Single Family Home	363	Dwelling Units	868
Community Center	4,000	SF	4
Total Commercial Space (i.e., supermarket, health club, restaurant, other)	82,000	SF	176
Parks/Open Space/Creek Corridor	84.3	acres	0

The Project is anticipated to be fully built and occupied in the year 2024, with a service population (SP) (residents and employees) of 2,416.

## 1.2 SCA GHG-1

The City of Oakland applies *SCA GHG-1: Greenhouse Gas (GHG) Reduction Plan* to all projects which result in a net increase in GHG emissions. This GGRP is responsive to the requirements of SCA GHG-1, namely that the “project applicant shall retain a qualified air quality consultant to develop a Greenhouse Gas (GHG) Reduction Plan for City review and approval.” The basic requirements of SCA GHG-1 are stated below, in text from SCA GHG-1:

The goal of the GHG Reduction Plan shall be to increase energy efficiency and reduce GHG emissions to below at least one of the Bay Area Quality Management District’s (BAAQMD’s) CEQA Thresholds of Significance (1,100 metric tons of CO<sub>2</sub>e per year or 4.6 metric tons of CO<sub>2</sub>e per year per service population) AND to reduce GHG emissions by 36 percent below the project’s “adjusted” baseline GHG emissions (as explained below) to help achieve the City’s goal of reducing GHG emissions. The GHG Reduction Plan shall include, at a minimum, (a) a detailed GHG emissions inventory for the project under a “business-as-usual” scenario with no consideration of project design features, or other energy efficiencies, (b) an “adjusted” baseline GHG emissions inventory for the project, taking into consideration energy efficiencies included as part of the project (including the City’s Standard Conditions of Approval, proposed mitigation measures, project design features, and other City requirements), (c) a comprehensive set of quantified additional GHG reduction measures available to further reduce GHG emissions beyond the adjusted GHG emissions, and (d) requirements for ongoing monitoring and reporting to demonstrate that the additional GHG reduction measures are being implemented.

The GGRP shall be implemented beginning with Project construction, for instance construction of physical GHG reduction measures incorporated into the design of the Project. During and after construction, the applicant is committed to ongoing monitoring and reporting to ensure that GHG reduction measures are being implemented.

The GHG Reduction Plan shall be considered fully attained when project emissions are less than either of the two potentially applicable numeric BAAQMD CEQA Thresholds AND GHG emissions are 36 percent below the project’s “adjusted” baseline GHG emissions, as confirmed by the City through an established monitoring program. Monitoring and reporting activities will continue as directed by SCA GHG-1.

As part of this GHG Reduction Plan, Ramboll Environ prepared a detailed GHG emissions inventory for the project under a 2005 “business-as-usual” scenario (hereafter called the “2005 BAU Project”) with no consideration of regulatory standards adopted thereafter designed to reduce GHG emissions or other energy efficiencies. This 2005 BAU Project inventory is compared to an “adjusted” baseline GHG emissions inventory for the Project (hereafter called the “Project scenario”), taking into consideration energy efficiencies included as part of the Project (including the City’s Standard Conditions of Approval, proposed mitigation measures, project design features, other City requirements, and federal, state and other local regulatory standards enacted since 2005). GHG emission sources associated with the Project include both on-site and off-site sources. On-site sources include off-road mobile equipment (loaders, tractors, etc.) during construction, on-road vehicles, and area sources such as hearths. Off-site sources include on-road vehicles and emissions from solid waste disposal. GHG emissions from purchased electricity, including for the supply, distribution, and treatment of water, are off-site sources. A summary of this analysis is provided in Table 3.

## 2. SUMMARY OF GHG EMISSIONS

Emissions representing two operational years were considered: 2005 and 2024. The year 2005 is the baseline year because the City of Oakland's GHG reduction goal is based on existing GHG emissions in the year 2005. The year 2024 is the year when construction of the project is anticipated to be complete, so this case is called the "Full Buildout" year.

The inventories for each year were based on information from the Project Description, information provided by the Project Sponsor to Environmental Science Associates (ESA) for the Draft Environmental Impact Report (DEIR), as well as information from the Project traffic consultant. Ramboll Environ prepared a detailed GHG emissions inventory for the project under a 2005 BAU scenario with no consideration of project design features or other energy efficiencies. ESA prepared the "adjusted" baseline GHG emissions inventory for the project in the DEIR, taking into consideration energy efficiencies included as part of the project (including proposed mitigation measures, project design features, and other City requirements). In this update of the GGRP, Ramboll Environ has updated the mobile "adjusted" baseline GHG emissions inventory from ESA, using the same tools, to incorporate revisions to estimates of vehicle miles traveled and the trip reduction benefits of the proposed TDM Plan. Details on the emissions inventories are provided below for the existing conditions, Project construction, and the proposed Project.

### 2.1 Summary of Existing Conditions GHG Emissions

As noted above, although there were existing historical uses at the site of the NMCO, at the time of the Notice of Preparation of the Project EIR, only minimal existing uses were active. To conservatively overestimate Project impacts, no GHG inventory of existing sources was subtracted from the Project GHG inventory (i.e., a "zero baseline").

### 2.2 Proposed One-time Project GHG Emissions

#### 2.2.1 Summary of Construction GHG Emissions

As reported in the analysis performed by ESA for the DEIR for the Project, total construction emissions are 17,872 metric tons (MT) of carbon dioxide equivalents (CO<sub>2</sub>e) over the three phases of construction. There may be a construction scenario with lower total GHG emissions, but the higher estimate is used here to be conservative. For inclusion in the ongoing GHG emissions inventory, this amount is annualized over the anticipated 40-year life of the Project, to an amount of 447 MT CO<sub>2</sub>e per year. ESA used the California Emission Estimator Model version 2013.2.2 (CalEEMod®) to estimate construction emissions for the Project. The California Air Pollution Control Officers Association (CAPCOA) in collaboration with Ramboll Environ (as ENVIRON International Corporation) developed CalEEMod® for use in developing emission inventories suitable for CEQA analyses.

#### 2.2.2 Summary of Land-Use Change and Vegetation GHG Emissions

The Project is responsible for the one-time change in land use from grassland over the former building pads at the NMCO to developed residential landscapes. The Project will also plant 910 net new trees, of mixed hardwood. These two combined changes result in a net one-time GHG benefit of 441 MT CO<sub>2</sub>e. As with the construction GHG emissions, these are annualized over the 40-year life of the project, as a credit of 11 MT CO<sub>2</sub>e/year.



## **2.3 Proposed Ongoing Project GHG Emissions**

Two analyses were prepared for proposed Project emissions, to reflect the Full Buildout Project and 2005 BAU scenarios. The use of 2005 BAU Project to represent the Project without adjustment for statewide and Project design GHG reduction measures is consistent with the emissions reductions goal described in SCA GHG-1. The Project emissions scenario represents the Project as it must be constructed. Accordingly, it includes all local, state, and federal measures expected to be implemented by 2024, including the SCAs.

### **2.3.1 Methodology for Project Emissions Inventories**

The Project operations were analyzed for the years 2005 and 2024, at full buildout. ESA's analysis of Project GHG emissions uses CalEEMod® version 2013.2.2, as do Ramboll Environ's updates to mobile source emissions. Consistent with the methodology in the Oakland ECAP, Ramboll Environ analyzed the 2005 BAU Project as if it was operating in 2005, and consistent with CalEEMod® version 2013.2.2.

The GHG inventories are divided by source category to cover

1. Area Sources
2. Purchased electricity use not related to water usage
3. Natural gas use
4. Water usage, including purchased electricity use
5. Waste
6. Mobile Sources.

Each source category is discussed separately below.

#### **2.3.1.1 Area Sources**

The proposed Project includes area sources such as architectural coatings, consumer products use, hearths, and landscaping equipment. CalEEMod® does not consider architectural coatings and consumer products to be sources of GHG.

Hearth emissions for the 2024 Project were calculated with CalEEMod®. BAAQMD Rule 6-3-306 does not allow wood stoves in new building construction after November 1, 2016, so the percentage of dwelling units with wood stoves was assumed to be zero. The CalEEMod® default count of dwelling units with wood stoves was assumed to instead have natural gas fireplaces.

Hearth emissions for the 2005 BAU Project were calculated consistent with CalEEMod® methods, assuming the default mix of wood and natural gas hearths. Although BAAQMD Rule 6-3-306 does not allow wood stoves in new building construction after November 1, 2016, the 2005 BAU Project does not reflect the implementation of this new rule, as the new rule is not considered business as usual for 2005 activity levels. The count of hearths and the operation of hearths from CalEEMod® were used with the emission factors in Table D5.2 of Appendix D of the CalEEMod® User's Guide to estimate hearth emissions.

The Project land uses will employ gasoline and diesel landscaping equipment. Emissions from lawn and garden equipment are estimated using CalEEMod®. CalEEMod®'s emissions estimates are based on emission factors for the landscaping equipment from the California Air Resources Board (ARB) OFFROAD2011 model.

### **2.3.1.2 Purchased Electricity Not Related to Water Use**

The Oak Knoll Project includes operational emissions associated with purchased electricity for lighting, heating, household electronics, electric vehicle charging, and other uses not associated with water supply, treatment, and distribution. CalEEMod® estimates emissions based on the type and size of land uses associated with the Project, as shown in Table 1. ESA adjusted the building envelope electricity usage for the 2024 Project to account for the 2016 Title 24 building energy efficiency standards, which will be in effect at the commencement of Project construction. The more stringent measures proposed for the 2019 Title 24 building energy efficiency standards are not included by ESA as the 2019 Title 24 building energy efficiency standards have not yet been adopted.

For estimating GHG emissions from electricity use for the 2024 Project, the Pacific Gas and Electric Company (PG&E) CO<sub>2</sub> intensity factor for 2020 was used in place of the default energy intensity in CalEEMod®.<sup>1</sup> This electricity emission factor for GHG is used for 2024, as PG&E has not published an estimated emission factor for 2024. The 2005 BAU Project uses the CalEEMod® emission factor for CO<sub>2</sub> intensity in 2005, not the anticipated 2020 emission factor. This use of the historical emission factor for the 2005 case is consistent with the Oakland ECAP. In addition to the difference in CO<sub>2</sub> intensity between the 2005 BAU Project and Project inventories, the 2005 BAU Project inventory does not account for increases in building energy efficiency from the Title 24 building energy efficiency standards that have been enacted since 2005.

### **2.3.1.3 Natural Gas**

The Oak Knoll Project includes operational emissions associated with on-site natural gas combustion. ESA estimated emissions using CalEEMod® based on the type and size of land uses associated with the Project, as shown in Table 1. ESA adjusted the building envelope natural gas usage for the Project to account for the 2016 Title 24 building energy efficiency standards, which will be in effect at the commencement of Project construction. The 2005 BAU Project inventory does not account for increases in building energy efficiency from the post-2005 Title 24 building energy efficiency standards. Like the 2024 Project case, the emission factors used to estimate 2005 BAU emissions from natural gas combustion are from Table D8.2 of the CalEEMod® User's Guide. The CH<sub>4</sub> (methane) and N<sub>2</sub>O (nitrous oxide) emission factors used are from CalEEMod®. The global warming potentials for CH<sub>4</sub> and N<sub>2</sub>O are 21 and 310, respectively, consistent with CalEEMod®.

### **2.3.1.4 Water Use, Including Purchased Electricity**

Electricity is required to supply, treat, and distribute water and wastewater, and as such water use is a source of GHG emissions. The water use estimate of 207,000 gallons per day for the Project is from East Bay Municipal Utility District (EBMUD). As with GHG emissions from purchased electricity not related to water use, ESA used the PG&E CO<sub>2</sub>e intensity factor for 2020 in place of the default energy intensity in CalEEMod® for the 2024 Project. This electricity emission factor for GHG is used for 2024, as PG&E has not published an estimated emission factor for 2024. As described in Section 2.3.1.2, the CalEEMod® emission factor for

---

<sup>1</sup> Pacific Gas and Electric Company (PG&E). Greenhouse Gas Emission Factors: Guidance for PG&E Customers. April. Available online at: [http://www.pge.com/includes/docs/pdfs/shared/environment/calculator/pge\\_ghg\\_emission\\_factor\\_info\\_sheet.pdf](http://www.pge.com/includes/docs/pdfs/shared/environment/calculator/pge_ghg_emission_factor_info_sheet.pdf).

2005 CO<sub>2</sub> intensity is used for water-related purchased electricity emissions from the 2005 BAU Project. The water demand is the same for 2005 as for the 2024 Project.

### **2.3.1.5 Waste**

Waste generated by the Oak Knoll project will result in GHG emissions, which ESA estimated using CalEEMod®. The Oakland ECAP accounts for the City of Oakland Zero Waste goal, which reduces GHG emissions from waste by 89% between 2005 and 2020.

### **2.3.1.6 Mobile Sources**

The Project would generate vehicle trips from residents traveling to and from the site and non-residents traveling to and from the site for work or commercial purposes. ESA relied on the trip generation data in the transportation impact analysis prepared by Fehr & Peers to estimate 2024 Project emissions using CalEEMod®. The 2005 BAU Project mobile source GHG emissions rely on the same trip generation data and 2005 mobile fleet emission factors, consistent with the methods of the ECAP analysis. The emission factors for 2005 and 2024 are taken from EMFAC2014. The trip generation rates and trip lengths in the 2005 BAU Project do not include the Project Transportation Demand Management (TDM) Program.

The calculation of vehicle miles traveled (VMT) for both the 2005 BAU and 2024 Project relies on the trip generation data in the transportation impact analysis prepared by Fehr & Peers. Trip generation rates are consistent with those presented in the Transportation and Circulation chapter of the DEIR. The Project transportation impact analysis uses average weekday trip rates. For Saturday and Sunday trip generation rates, Ramboll Environ used methods consistent with Fehr & Peers' transportation impact analysis along with Saturday and Sunday trip rates from the ITE Trip Generation Manual, 9th Edition. The trip generation data accounts for a mode-split trip rate reduction of 3.1%, which quantifies the shift in mode split from vehicles to other modes of transportation, including walking, biking and transit. The estimated VMT use the trip generation rates from the Transportation and Circulation chapter of the DEIR described above and primary trip lengths from the 2012 California Household Travel Survey (CHTS), conducted by the California Department of Transportation (Caltrans). Table GGRP-3 of Appendix A shows the average trip length for each trip type.

The GHG emissions associated with on-road mobile sources include running and starting exhaust emissions. Starting and evaporative emissions are associated with the number of starts or time between vehicle uses and the assumptions used in determining these values are described below. Project traffic emission factors are from EMFAC2014 for the vehicle fleet mix in Alameda County. The EMFAC2014 model is a newer on-road emissions model than the EMFAC2011 model incorporated in the CalEEMod® model. The emission factors taken from EMFAC2014 represent 2005 for the 2005 BAU case, including the 2005 fleet mix, and 2024 for the 2024 Project case, including the 2024 fleet mix. Alameda County fleet emissions reported by the EMFAC2014 model for running emissions were converted to units of grams of pollutant emitted per VMT using the daily VMT in the County. Alameda County fleet emissions reported by EMFAC2014 for idling and starting emissions were converted to units of grams of pollutant emitted per trip for idling and starting emissions.

## **2.4 Current State and Local Requirements that Reduce GHG Emissions**

### **2.4.1 State and Local Requirements Other Than the Transportation Demand Management (TDM)**

The following state programs and existing City requirements will reduce GHG emissions from the 2005 BAU scenario:

- The Project Transportation Demand Management (TDM) program will reduce VMT by 21%, which reduces on-road mobile source emissions
- The Pavley Act and ACC programs reduce on-road vehicle fleet emissions
- The City of Oakland's Zero Waste goal will reduce GHG emissions from waste by 89%
- The Renewable Portfolio Standard will reduce GHG from PG&E electricity generation
- The BAAQMD Rule 6-3 eliminates wood-fired hearths in new homes, thereby reducing GHG emissions per hearth
- Increased penetration of electric vehicles will reduce GHG emissions from on-road mobile sources, even without assuming mandated changes to charging infrastructure
- Increased residential and nonresidential building energy efficiency due to 2016 and 2019 Title 24 standards (in compliance with SCA GHG-2)

These requirements, as well as the TDM, are considered as part of the Project scenario. The TDM, due to its large impact on GHG emissions, is discussed separately below.

#### **2.4.2 TDM**

As required by SCA TRA4, the Project will implement a TDM program to reduce VMT by 21%. The VMT reduction will have a direct effect on running exhaust emissions from on-road vehicles.

#### **2.4.3 Phasing**

The Project will be constructed in three phases, with operations commencing in sequence for the same three phases. Table 2 shows the operational GHG emissions for each of the three phases of construction individually as well as at Full Buildout of the Project. The emissions for each phase are specific to its first year of operation, which is expected to be the highest-emitting year due to the planned improvements to the on-road vehicle fleet. Table 2 shows the emissions of Phase I in its first operational year, 2022, and the emissions of Phase II in its first operational year, 2023. Phase-specific land-use inputs match the phase and project description and incorporate data from traffic consultants.

As shown in Table 2, Phase I and Phase II operations are above the efficiency threshold of 4.6 (MT CO<sub>2</sub>e per service population per year (MT CO<sub>2</sub>e/SP/year). In the time period between the completion of Phase II construction and Full Buildout, the Project Sponsor will mitigate GHG emissions from partial-Project operation to below the efficiency threshold of 4.6 MT CO<sub>2</sub>e/SP/year. The Project Sponsor may purchase sufficient carbon offsets (2,165 MT per year [MT/yr] of Phase I operations in 2022 and 2,061 MT/yr of Phase I and II operations in 2023) to reduce the Phase I and II cumulative phasing exceedances below the efficiency threshold. Because this is a temporary exceedance, which is reduced at Full Buildout, the purchase of carbon offsets is an appropriate way to address the exceedance before full buildout. To the extent that GHG-reducing Project design features are added from the menu of potential measures listed in Table 4 herein, those features may sufficiently reduce operational GHG emissions per service population during Phase I and Phase I plus Phase II such that a reduced level of mitigation is required. If the project applicant chooses to install Project design features that minimize GHGs, the Project applicant would provide the City with an updated report of the Project's operational emissions by phase and would be required to mitigate any remaining exceedance.

<b>Table 2. Operational Emissions by Phase</b>					
	<b>Project Phase</b>				
	<b>I, Operational Year 2022</b>	<b>II, Operational Year 2023</b>	<b>I and II, Operational Year 2023</b>	<b>III, Operational Year 2024</b>	<b>Full Buildout, Operational Year 2024</b>
<b>Project Description</b>					
Housing Units	332	263	595	340	935
Commercial Development (square feet) <sup>a</sup>	82,000	0	82,000	0	82,000
Service Population	974	629	1,603	813	2,416
<b>GHG Emissions by Source (MT CO<sub>2</sub>e)</b>					
Total operational emissions <sup>b</sup>	6,420	2,827	9,067	2,072	10,985
Annualized construction <sup>c</sup>	241	143	384	63	447
Annualized net vegetation	-11	0	-11	0	-11
<b>TOTAL ANNUAL GHG EMISSIONS</b>	<b>6,650, in 2022</b>	<b>2,970, in 2023</b>	<b>9,440, in 2023</b>	<b>2,135, in 2024</b>	<b>11,421, in 2024</b>
Mass Emissions Threshold of 1,100 MT CO <sub>2</sub> e Exceeded?	Yes	Yes	Yes	Yes	Yes
Emissions per Service Population per Year	6.8	4.7	5.9	2.6	4.7
Efficiency Threshold of 4.6 MT CO <sub>2</sub> e Exceeded?	Yes	Yes	Yes	No	Yes
Offsets required (MT/year)	2,170	77	2,066	0	578
Offsets required for cumulative phases (MT/year) <sup>d</sup>	2,170	See Phases I and II	2,066	See Full Buildout	578
Notes					
a The CalEEMod® runs in Appendix I of the DEIR and those updated for this Greenhouse Gas Reduction Plan use 86,000 square feet of commercial uses, which includes the 4,000 square feet dedicated to the community center.					
b Incorporates all TDM Program (SCA TRA-4) measures in each development phase and applicable requirements for green building measures (SCA GHG-2).					
c Incorporates on-site crushing scenario for Phase 1 construction and construction-related air pollutant controls (SCA AIR-1).					
d In 2023, the Phase I only emissions decrease from 6,420 MT CO <sub>2</sub> e per year to 6,239 MT CO <sub>2</sub> e per year due to changes in emission factors for the on-road fleet. This reduction means the total Phase I plus Phase II offsets required are only 2,066 MT CO <sub>2</sub> e per year.					

#### 2.4.4 Comparison of 2005 BAU and 2024 Project Emissions Inventories

Table 3 shows the 2005 BAU Project and 2024 Project GHG inventories, with a column showing the percent reduction in emissions from the 2005 BAU Project inventory by source category.

Emissions from area sources (hearths and landscaping), decrease by 18% from the 2005 BAU Project scenario due to the replacement of wood-fired hearths with natural gas fireplaces, as required by BAAQMD Rule 6-3.

Emissions related to purchased electricity and natural gas decrease by 43%, due to the combined impacts of increased building energy efficiency and reductions in the carbon intensity of electricity provided by PG&E. These reductions are from the Title 24 building energy efficiency standards and the state Renewables Portfolio Standard.

Emissions related to water use, which are from wastewater treatment and the purchased electricity used to supply, distribute and treat the water, are reduced by 54%, due to the state Renewables Portfolio Standard lowering the carbon intensity of purchased electricity between the 2005 BAU Project and 2024 Project scenarios.

Between the 2005 BAU Project and 2024 Project scenarios, emissions from waste are reduced as Oakland implements measures to meet its Zero Waste goal by 2020. This is an 88% reduction in GHG emissions from waste.

On-road mobile source emissions decrease by 27% between the 2005 BAU Project scenario and the 2024 Project scenario. The fleet average emission factors from EMFAC2014 show that the vehicle fleet is more efficient by 2024.

<b>Table 3: Summary of Full Buildout 2005 BAU Project and 2024 Project Greenhouse Gas Emissions (MT/yr CO<sub>2</sub>e)</b>			
<b>Source Category</b>	<b>GHG Emissions for 2005 BAU Project, Full Buildout (MT CO<sub>2</sub>e)</b>	<b>GHG Emissions for 2024 Project, Full Buildout (MT CO<sub>2</sub>e)</b>	<b>Percent Reduction from 2005 BAU Project</b>
Hearths and Landscaping	105	86	18%
Purchased Electricity – non-water related	2,344	2,557	43%
Natural Gas	2,106		
Water Use	221	101	54%
Waste Disposed	528	61	88%
On-Road Exhaust	11,205	8,180	27%
Annualized Construction	447	447	0%
Annualized Net Vegetation Emissions	-11	-11	0%
<b>Total</b>	<b>16,942</b>	<b>11,421</b>	<b>32.6%</b>

Table 3 shows that the Project achieves a 32.6% reduction from the 2005 BAU Project scenario.

#### **2.4.5 GHG Emissions Per Service Population**

In addition to the total project emissions, Ramboll Environ also calculated the GHG efficiency of the Project on a per-service population basis. The service population is from Chapter 4 of the DEIR. At full buildout, the Project population is 2,416 residents and employees and annual GHG emissions are 11,421 MT CO<sub>2</sub>e/year. The Project GHG emissions on a per-service population basis are 4.7 MT CO<sub>2</sub>e/SP/year.

### 3. PROPOSED GHG REDUCTION MEASURES

SCA GHG-1 requires the GGRP to both reduce GHG emissions per service population to below 4.6 MT CO<sub>2</sub>e/SP/year and to at least 36% below the 2005 BAU emissions. As shown in Section 2.4.4, the Project emissions are 32.6% below the 2005 BAU emissions. This section describes the reduction measures that are proposed to achieve the emissions reductions required by SCA GHG-1.

To meet the SCA GHG-1 requirements, even after complying with other SCAs, local, and state regulations, the Project must reduce its GHG emissions to meet the 36% reduction below BAU and 4.6 MT CO<sub>2</sub>e/SP/year criteria. To do this, the Project must reduce its GHG emissions by 578 MT CO<sub>2</sub>e/year (3.4% reduction). As discussed below and summarized in Table 4, Ramboll Environ proposes a menu of measures that either singularly or in combination would accomplish the required numeric reductions.

<b>Table 4: Summary of Mitigation Measures That Would Achieve The City's SCA GHG-1 Requirements</b>			
<b>Source Category</b>	<b>Mitigation Measure</b>	<b>Reduction (MT CO<sub>2</sub>e)</b>	<b>Percent Reduction</b>
Hearths	Elimination of natural gas fireplaces	45	0.27%
Purchased Electricity – non-water related	Solar photovoltaic panels (>2.8 kW each) on townhomes	Up to 0.56 per townhome	1.9% from 572 townhomes
	Solar photovoltaic panels (>4.6 kW each) on single-family homes	Up to 0.90 per single-family home	1.9% from 363 single family homes
	Solar photovoltaic panels on commercial roof tops	137 per 72,000 square feet of commercial roof space	0.8% per 72,000 square feet of commercial roof space
	Solar photovoltaic arrays over commercial parking lots	166 per 87,210 square feet of parking lot	1.0% from 87,210 square feet of parking lot
	Ground-mounted solar	1.9 per 1,000 square feet	



<b>Table 4: Summary of Mitigation Measures That Would Achieve The City’s SCA GHG-1 Requirements</b>			
<b>Source Category</b>	<b>Mitigation Measure</b>	<b>Reduction (MT CO<sub>2e</sub>)</b>	<b>Percent Reduction</b>
	Require use of electrically powered landscape equipment in the Project area	12	0.07%
On-Road Exhaust	Install electric vehicle chargers in townhomes <sup>1</sup>	1.6 per townhome	Up to 1.2%
	Install electric vehicle chargers in single-family homes <sup>2</sup>	2.6 per single-family home	Up to 1.3%
	Install electric vehicle chargers in commercial parking lots <sup>3</sup>	19 per charger	Up to 3.4%, assuming 31 chargers
Vegetation Emission Reductions	Plant trees in the Project area (mixed hardwood)	1.84 per 100 trees	0.01% for 100 trees
Municipal Reductions	Install LED street lights for the 230 new street lights at the Project <sup>4</sup>	30 per 230 street lights	0.27%
Annual Carbon Offsets	Carbon offsets	Up to 578	Up to 3.4%
<b>Notes</b> <ol style="list-style-type: none"> <li>Assumes that all townhomes are equipped with an electric vehicle charger and that 20% of all townhomes use an electric vehicle for half of their vehicle trips.</li> <li>Assumes that all single-family homes are equipped with an electric vehicle charger and that 20% of all single-family homes use an electric vehicle for half of their vehicle trips.</li> <li>Assumes ten hours of charging per day per charger</li> <li>Assumes LED lights are used in place of high-pressure sodium lights</li> </ol>			

This GGRP requires the project applicant to implement any mix of the measures listed in Table 4, provided that the mix results in emissions at least 36% below BAU. A reduction to 36% below BAU means the project will achieve emissions per service population of 4.5 MT CO<sub>2e</sub>/SP/yr.

The SCA GHG-1 requirements could be met by supplying renewable electricity to meet residential electricity demand not related to water usage. This is achievable through on-site solar generation in this location, based on local meteorology, assuming at least 2.8 kW solar

systems are installed on each multi-family home and that at least 4.6 kW systems are installed on each single-family home.<sup>2</sup> This also would be achievable through a mix of residential systems and systems on the commercial or open space portions of the Project.

The Project also could reduce emission from mobile sources by installing electric car chargers in residential garages and commercial parking lots, which is anticipated to increase electric car penetration. The current assumptions of EMFAC2014 do not account for changes in infrastructure that would encourage electric cars, promoting early adoption. Building electric vehicle chargers into new homes and in commercial parking areas may lead to a higher localized use of electric vehicles, which would reduce the Project's mobile GHG emissions inventory.

The California Public Utilities Commission (CPUC) has set a goal that by 2020, all new residential construction in California will be of Zero Net Energy (ZNE) homes. "ZNE" is defined as producing as much energy as what is consumed over the course of a year. This is anticipated to be codified in the 2019 Title 24 building energy efficiency standards. The current CPUC goal for commercial buildings is that they are also ZNE by 2030. This Project will comply with the Title 24 building energy efficiency standards in place at the time of construction. To the extent that homes built after 2019 are designed to meet future Title 24 standards, the emissions reductions in the Project scenario would exceed what is shown here, leading to lower emissions per service population and a greater percent reduction from 2005 BAU.

Implementing measures to reduce Project emissions and then providing sufficient renewable energy to meet the City's SCA reduction requirements through on-site physical design features is preferred over purchasing carbon offsets.

Alternatively, the Project could provide carbon offsets only or combine carbon offsets with solar panels and other emission reduction measures. If the project applicant chooses to meet some or all of the City's SCA requirements by purchasing offsets on an annual and permanent basis, the offsets will be purchased according to the City of Oakland's preference, which is, in order of City preference: (1) within the City of Oakland; (2) within the San Francisco Bay Area Air Basin; (3) within the State of California; then (4) elsewhere in the United States.

---

<sup>2</sup> Annual renewable energy generated per unit from the National Renewable Energy Laboratory (NREL) PVWatts® Calculator, default inputs which account for the efficiency of a roof mount solar system with a 20 degree roof slope, south roof direction, 14% system losses, 96% inverter efficiency, and 1.1 DC to AC Size Ratio for the Oakland Metropolitan Airport.

## 4. IMPLEMENTATION AND ANNUAL REPORTING

Following submission of this GGRP to the City of Oakland, the City must approve the plan. Subsequent to approval by the City, the master developer and subsequent builders will implement the approved GGRP during construction, including “1) submitting drawings of GGRP measures to the City Planning Director or his/her designee for review and approval, 2) implementing off-site measures, or 3) purchasing carbon credits.” For the Oak Knoll Project, this may include submitting drawings of proposed on-site solar panels or receipts for carbon credits.

In the operational phase of the Project, the Homeowners Association and commercial tenants will prepare and submit annual GGRP monitoring reports to the City of Oakland until the goals of SCA GHG-1 are fully attained. Full attainment is reached when project emissions are less than 4.6 MT CO<sub>2</sub>e/sp/yr and GHG emissions are 36 percent below the 2005 BAU Project’s GHG emissions, as confirmed by the City through an established monitoring program.

### 4.1 Plans for Future Reporting

Reports that verify annual operational inventories will be submitted to the City of Oakland on an ongoing basis. The GHG emissions metrics discussed in Sections 2.4.4 can be used to determine the overall inventory once the Project is in operation, although with time the emissions inventory methods may evolve. Monitoring of the GGRP by the City of Oakland will begin with Project construction, and the project applicant will begin reporting of Project emissions at the completion of each phase of project development/full occupancy and then again, after full Project construction and occupancy. If in five successive years (including at least one year reflecting complete development/occupancy of the entire Project), the Project is found to meet the stated GGRP goal, additional monitoring and reporting shall not be required.

## **5. SUMMARY**

This GHG Reduction Plan demonstrates the Oak Knoll Project can meet the goals of SCA GHG-1. Specifically, the goals met by this GGRP are to increase energy efficiency and reduce GHG emissions to below the applicable BAAQMD CEQA Threshold of Significance pertaining to an efficiency metric based on the Project's total population, and to reduce GHG emissions by 36 percent below 2005 BAU Project GHG emissions, consistent with the City's ECAP.

## **APPENDIX A**

### **SUPPORTING CALCULATIONS**

**Table GGRP-1**  
**Land Use Summary, Full Buildout**  
**Oak Knoll Mixed Use Project**  
**Greenhouse Gas Reduction Plan**  
**Oakland, California**

<b>Project Land Use</b>	<b>CalEEMod Land Use Subtype<sup>1</sup></b>	<b>Size</b>	<b>Units</b>	<b>Population<sup>2</sup></b>
Townhomes	Condo/Townhouse	572	Units	1,368
Single Family Detached	Single Family Home	363	Units	868
Community Center	Commercial- Government (Civic Center)	4,000	SF	4
Retail (Gross Leasable)	Retail - Supermarket	66,000	SF	138
Community Center Related Commercial	Recreational - Health Club	10,000	SF	20
Retail (Gross Leasable)	Recreational - High Turnover Restaurant	6,000	SF	18
Parking Lot	Parking Lot	87,210	SF	0
Parking	Parking	26	acres	0
Open Space	Open Space	84.3	acres	0

**Notes:**

1. Land uses shown are CalEEMod Land Use Subtypes and are matched based on the DEIR Project Description.
2. Residential and Commercial Population is from the Population and Housing Chapter of the DEIR.

**Table GGRP-2**  
**Trip Generation Rates**  
**Oak Knoll Mixed Use Community Plan Project**  
**Oakland, California**

**Project Weekday Trips**

<b>Trip Generation Land Use Type<sup>1</sup></b>	<b>Size</b>	<b>Units</b>	<b>Weekday trips from ITE</b>	<b>Weekday Trips with Mode Split Adjustment</b>	<b>Weekday Trips with Mode Split Adjustment AND TDM</b>
Condo/Townhouse	572	Units	3,320	2,927	2,537
Single Family Housing	363	Units	3,460	3,053	2,653
Regional Shopping Center	82	1000sf	5,970	5,270	4,580
Internal Trips	--	--	--	1,110	1,110
<b>Oak Knoll Total Project Trips</b>			<b>12,750</b>	<b>12,360</b>	<b>10,880</b>

**Project Saturday Trips**

<b>Trip Generation Land Use Type<sup>1</sup></b>	<b>Size</b>	<b>Units</b>	<b>Saturday trips from ITE</b>	<b>Saturday Trips with Mode Split Adjustment</b>	<b>Saturday Trips with Mode Split Adjustment AND TDM</b>
Condo/Townhouse	572	Units	3,240	2,860	2,490
Single Family Housing	363	Units	3,600	3,180	2,770
Regional Shopping Center	82	1000sf	8,150	7,190	6,240
Internal Trips	--	--	--	1,300	1,300
<b>Oak Knoll Total Project Trips</b>			<b>14,990</b>	<b>14,530</b>	<b>12,800</b>

**Table GGRP-2  
Trip Generation Rates  
Oak Knoll Mixed Use Community Plan Project  
Oakland, California**

**Project Sunday Trips**

<b>Trip Generation Land Use Type<sup>1</sup></b>	<b>Size</b>	<b>Units</b>	<b>Sunday trips from ITE</b>	<b>Sunday Trips with Mode Split Adjustment</b>	<b>Sunday Trips with Mode Split Adjustment AND TDM</b>
Condo/Townhouse	572	Units	2,770	2,440	2,120
Single Family Housing	363	Units	3,130	2,760	2,400
Regional Shopping Center	82	1000sf	5,500	4,850	4,210
Internal Trips	--	--	--	990	990
<b>Oak Knoll Total Project Trips</b>			<b>11,400</b>	<b>11,040</b>	<b>9,720</b>

**Notes:**

1. Land Use Type aggregation from Fehr & Peers traffic study.
2. Trip rates from Fehr & Peers traffic study and include
  - a Mode Split Adjustment Factor of 3.1%, applied to all land uses
  - an Internalization Trip Capture Factor of 9% from the ITE Trip Generation Handbook
  - a Complete Streets adjustment of 3% applied to all land uses
  - TDM reductions of 9%



**Table GGRP-3  
Trip Lengths  
Oak Knoll Mixed Use Project  
Greenhouse Gas Reduction Plan  
Oakland, California**

Trip Generation Land Use Type <sup>1</sup>	Home-Work Trip Length <sup>2</sup>	Home-Shop Trip Length <sup>2</sup>	Home-Other Trip Length <sup>2</sup>	Home-Work Trip %	Home-Shop Trip %	Home-Other Trip %	Commercial-Commercial Trip Length	Commercial-Work Trip Length	Commercial-NonWork Trip Length	Commercial-Commercial Trip %	Commercial-Work Trip %	Commercial-NonWork Trip %	Primary Trip <sup>2</sup> %	Diverted Trip <sup>2</sup> %	Pass-By Trip <sup>2</sup> %	Average Primary Trip Length <sup>3</sup> (miles)	Average Overall Trip Length <sup>3</sup> (miles)
Condo/Townhouse	11	6.5	6.5	0.261	0.291	0.448	6.5	11	5.7	0	0	0	1	0	0	7.7	7.7
Single Family Housing	11	6.5	6.5	0.261	0.291	0.448	6.5	11	5.7	0	0	0	1	0	0	7.7	7.7
Regional Shopping Center	11	6.5	5.7	0	0	0	6.5	11	5.7	0.647	0.163	0.19	0.54	0.35	0.11	7.1	4.5
Internal Trips	0.5	0	0	1	0	0	--	--	--	--	--	--	1	0	0	0.5	0.5

**Notes:**

1. Land Use Type aggregation from Fehr & Peers traffic study.
2. Trip length and trip type data from CalEEMod with adjustments by Fehr & Peers for each land use.
3. Internal Trip length from Fehr & Peers.

**Table GGRP-4  
Hearth Population, 2005 BAU  
Oak Knoll Mixed Use Project  
Greenhouse Gas Reduction Plan  
Oakland, California**

**Woodstoves Population Inputs in CalEEMod<sup>1</sup>**

	<b>Conventional %</b>	<b>Catalytic %</b>	<b>Non-Catalytic %</b>	<b>Pellet %</b>	<b>Wood Mass Fireplace (lb/year)</b>
<b>Multifamily Homes</b>	0	0.5	0.5	0	954.8
<b>Single Family Homes</b>	0	3.5	3.5	0	1,355.2

**Fireplace Population Inputs in CalEEMod<sup>1</sup>**

	<b>Wood Hearth %</b>	<b>Natural Gas %</b>	<b>Propane %</b>	<b>No Hearth %</b>	<b>Wood Mass Fireplace (lb/year)</b>
<b>Multifamily Homes</b>	14	55	0	31	92.4
<b>Single Family Homes</b>	45	55	0	0	215.6

**Notes:**

1. From Table 5.1 of CalEEMod User's Guide Appendix D.

**Table GGRP-5  
Hearth Emissions, 2005 BAU  
Oak Knoll Mixed Use Community Plan Project  
Greenhouse Gas Reduction Plan  
Oakland, California**

**Project Data**

<b>Housing Type</b>	<b>Project Dwelling Units</b>	<b>Count of Catalytic Woodstoves</b>	<b>Count of Non-Catalytic Woodstoves</b>	<b>Count of Wood Hearths</b>	<b>Count of Natural Gas Hearths</b>	<b>Count of Propane Hearths</b>	<b>Count of No Hearth</b>
Multi-Family Home	572	2.86	2.86	80.08	314.6	0	177.32
Single-Family Home	363	12.71	12.705	163.35	199.65	0	0

**Woodstoves Operation Inputs in CalEEMod<sup>1</sup>**

<b>Housing Type</b>	<b>Hours/day Woodstove</b>	<b>Day/year Woodstove</b>
Multi-Family Home	8.5	11
Single-Family Home	8.5	26

**Notes:**

1. From Table 5.1 of CalEEMod User's Guide Appendix D.

**Fireplace Operation Inputs in CalEEMod<sup>1</sup>**

<b>Housing Type</b>	<b>Hours/day Fireplace</b>	<b>Day/year Fireplace</b>	<b>MMBTU/hr-fireplace</b>
Single-Family Home	3.5	6.3	0.06
Multi-Family Home	3.5	4.3	0.06

**Notes:**

1. From Table 5.1 of CalEEMod User's Guide Appendix D.

**Table GGRP-5  
Hearth Emissions, 2005 BAU  
Oak Knoll Mixed Use Community Plan Project  
Greenhouse Gas Reduction Plan  
Oakland, California**

**Table D5.2 Hearth Emission Factors from CalEEMod User's Guide Appendix D, filtered for relevant hearth types**

Emission Factor by Pollutant <sup>1</sup> (lb/MMBTU)				
Hearth Type	CO2_BIO	CO2_NBIO	CH4	N2O
Natural Gas <sup>2</sup>	0	117.6470588	0.002254902	0.002156863
Propane	0	136.6120219	0.002185792	0.009836066
No Fireplace	0	0	0	0

Emission Factor by Pollutant <sup>1</sup> (lb/ton dry wood burned)				
Hearth Type	CO2_BIO	CO2_NBIO	CH4	N2O
Woodstoves Catalytic	2,952	0	11.6	0
Woodstoves Noncatal	2,952	0	16	0
Wood Fireplace	3,400	0	0	0.3

**Notes:**

1. From Table 5.2 of CalEEMod User's Guide Appendix D.

**Table GGRP-5  
Hearth Emissions, 2005 BAU  
Oak Knoll Mixed Use Community Plan Project  
Greenhouse Gas Reduction Plan  
Oakland, California**

**Project Emissions**

		<b>Project Emissions by Hearth Type (lb/year)</b>			
<b>Housing Type</b>	<b>Hearth Type</b>	<b>CO2_BIO</b>	<b>CO2_NBIO</b>	<b>CH4</b>	<b>N2O</b>
Single-Family Home	Natural Gas	0	31,075	1	1
	Woodstoves Catalytic	25,413	0	100	0
	Woodstoves Noncatalytic	25,413	0	138	0
	Wood Fireplace	59,871	0	0	5
Multi-Family Home	Natural Gas	0	33,311	1	1
	Woodstoves Catalytic	4,031	0	16	0
	Woodstoves Noncatalytic	4,031	0	22	0
	Wood Fireplace	12,579	0	0	1

**CO<sub>2</sub>e emissions:**                      92.5                      MT CO<sub>2</sub>e/year

1 metric ton =                      1.102 short tons

Global Warming Potentials (IPCC 1995)

CH<sub>4</sub> Global Warming Potential                      21

N<sub>2</sub>O Global Warming Potential                      310

**References:**

California Emissions Estimator Model (CalEEMod). Available online at <http://www.caleemod.com/>

Intergovernmental Panel on Climate Change (IPCC). 1995. Second Assessment Report. Available at [http://www.ipcc.ch/ipccreports/sar/wg\\_1/ipcc\\_sar\\_wg\\_1\\_full\\_report.pdf](http://www.ipcc.ch/ipccreports/sar/wg_1/ipcc_sar_wg_1_full_report.pdf)

**Table GGRP-6**  
**CalEEMod Output File with Landscaping Emissions**  
**Oak Knoll Mixed Use Project**  
**Greenhouse Gas Reduction Plan**  
**Oakland, California**

CalEEMod Version: CalEEMod.2013.2.2

Page 1 of 1

Date: 5/4/2016 9:18 AM

**Oak Knoll Mixed Use Project**  
**Alameda County, Annual**

**1.0 Project Characteristics**

**1.1 Land Usage**

Land Uses	Size	Metric	Lot Acreage	Floor Surface Area	Population
Government (Civic Center)	4.00	1000sqft	0.09	4,000.00	0
Other Asphalt Surfaces	26.00	Acre	26.00	1,132,560.00	0
Parking Lot	87.21	1000sqft	2.00	87,210.00	0
City Park	83.00	Acre	83.00	3,615,480.00	0
Health Club	10.00	1000sqft	0.23	10,000.00	0
High Turnover (Sit Down Restaurant)	6.00	1000sqft	0.14	6,000.00	0
Condo/Townhouse	572.00	Dwelling Unit	35.75	572,000.00	1209
Single Family Housing	363.00	Dwelling Unit	117.86	653,400.00	872
Supermarket	66.00	1000sqft	1.52	66,000.00	0

**1.2 Other Project Characteristics**

<b>Urbanization</b>	Urban	<b>Wind Speed (m/s)</b>	2.2	<b>Precipitation Freq (Days)</b>	63
<b>Climate Zone</b>	5			<b>Operational Year</b>	2014
<b>Utility Company</b>	Pacific Gas & Electric Company				
<b>CO2 Intensity (lb/MW hr)</b>	290	<b>CH4 Intensity (lb/MW hr)</b>	0.029	<b>N2O Intensity (lb/MW hr)</b>	0.006

### 1.3 User Entered Comments & Non-Default Data

Project Characteristics - 2020 carbon intensity from PG&E. This run is for Landscaping only.

Land Use - Population from DEIR

Construction Phase - This run is for Landscaping only.

Vehicle Trips - This run is for Landscaping only.

Vehicle Emission Factors - This run is for Landscaping only.

Vehicle Emission Factors -

Vehicle Emission Factors -

Woodstoves - This run is for Landscaping only.

Landscape Equipment - This run is for Landscaping only.

Energy Use - This run is for Landscaping only.

Water And Wastewater - This run is for Landscaping only.

Solid Waste - This run is for Landscaping only.0

Table Name	Column Name	Default Value	New Value
tblLandUse	Population	1,636.00	1,209.00
tblLandUse	Population	1,038.00	872.00
tblProjectCharacteristics	CO2IntensityFactor	641.35	290
tblWater	OutdoorWaterUseRate	98,892,952.02	0.00
tblWater	OutdoorWaterUseRate	23,495,108.20	0.00
tblWater	OutdoorWaterUseRate	487,036.65	0.00
tblWater	OutdoorWaterUseRate	362,490.24	0.00
tblWater	OutdoorWaterUseRate	116,246.95	0.00
tblWater	OutdoorWaterUseRate	14,910,357.12	0.00
tblWater	OutdoorWaterUseRate	251,619.66	0.00

### 2.0 Emissions Summary

	ROG	NOx	CO	SO2	Fugitive PM10	Exhaust PM10	PM10 Total	Fugitive PM2.5	Exhaust PM2.5	PM2.5 Total	Bio- CO2	NBio-CO2	Total CO2	CH4	N2O	CO2e

Percent Reduction	0.00	0.00	0.00	0.00	0.00	0.00	0.00	0.00	0.00	0.00	0.00	0.00	0.00	0.00	0.00	0.00
-------------------	------	------	------	------	------	------	------	------	------	------	------	------	------	------	------	------

## 2.2 Overall Operational Unmitigated Operational

	ROG	NOx	CO	SO2	Fugitive PM10	Exhaust PM10	PM10 Total	Fugitive PM2.5	Exhaust PM2.5	PM2.5 Total	Bio- CO2	NBio- CO2	Total CO2	CH4	N2O	CO2e
Category	tons/yr										MT/yr					
Area	27.6226	0.0843	7.1148	3.7000e-004		0.0378	0.0378		0.0378	0.0378	0.0000	11.3455	11.3455	0.0121	0.0000	11.5997
Total	27.6226	0.0843	7.1148	3.7000e-004	0.0000	0.0378	0.0378	0.0000	0.0378	0.0378	0.0000	11.3455	11.3455	0.0121	0.0000	11.5997

## Mitigated Operational

	ROG	NOx	CO	SO2	Fugitive PM10	Exhaust PM10	PM10 Total	Fugitive PM2.5	Exhaust PM2.5	PM2.5 Total	Bio- CO2	NBio- CO2	Total CO2	CH4	N2O	CO2e
Category	tons/yr										MT/yr					
Area	27.6226	0.0843	7.1148	3.7000e-004		0.0378	0.0378		0.0378	0.0378	0.0000	11.3455	11.3455	0.0121	0.0000	11.5997
Total	27.6226	0.0843	7.1148	3.7000e-004	0.0000	0.0378	0.0378	0.0000	0.0378	0.0378	0.0000	11.3455	11.3455	0.0121	0.0000	11.5997

	ROG	NOx	CO	SO2	Fugitive PM10	Exhaust PM10	PM10 Total	Fugitive PM2.5	Exhaust PM2.5	PM2.5 Total	Bio- CO2	NBio- CO2	Total CO2	CH4	N2O	CO2e
Percent Reduction	0.00	0.00	0.00	0.00	0.00	0.00	0.00	0.00	0.00	0.00	0.00	0.00	0.00	0.00	0.00	0.00

## 3.0 Construction Detail



This run is for Landscaping only.

#### 4.0 Operational Detail - Mobile

---

This run is for Landscaping only.

#### 5.0 Energy Detail

This run is for Landscaping only.

#### 6.0 Area Detail

---

##### 6.1 Mitigation Measures Area

	ROG	NOx	CO	SO2	Fugitive PM10	Exhaust PM10	PM10 Total	Fugitive PM2.5	Exhaust PM2.5	PM2.5 Total	Bio- CO2	NBio- CO2	Total CO2	CH4	N2O	CO2e
Category	tons/yr										MT/yr					
Mitigated	27.6226	0.0843	7.1148	3.7000e-004		0.0378	0.0378		0.0378	0.0378	0.0000	11.3455	11.3455	0.0121	0.0000	11.5997
Unmitigated	27.6226	0.0843	7.1148	3.7000e-004		0.0378	0.0378		0.0378	0.0378	0.0000	11.3455	11.3455	0.0121	0.0000	11.5997

##### 6.2 Area by SubCategory

###### Unmitigated

	ROG	NOx	CO	SO2	Fugitive PM10	Exhaust PM10	PM10 Total	Fugitive PM2.5	Exhaust PM2.5	PM2.5 Total	Bio- CO2	NBio- CO2	Total CO2	CH4	N2O	CO2e
SubCategory	tons/yr										MT/yr					

Architectural Coating	3.3846					0.0000	0.0000		0.0000	0.0000	0.0000	0.0000	0.0000	0.0000	0.0000	0.0000
Consumer Products	24.0057					0.0000	0.0000		0.0000	0.0000	0.0000	0.0000	0.0000	0.0000	0.0000	0.0000
Hearth	0.0000	0.0000	0.0000	0.0000		0.0000	0.0000		0.0000	0.0000	0.0000	0.0000	0.0000	0.0000	0.0000	0.0000
Landscaping	0.2322	0.0843	7.1148	3.7000e-004		0.0378	0.0378		0.0378	0.0378	0.0000	11.3455	11.3455	0.0121	0.0000	11.5997
<b>Total</b>	<b>27.6226</b>	<b>0.0843</b>	<b>7.1148</b>	<b>3.7000e-004</b>		<b>0.0378</b>	<b>0.0378</b>		<b>0.0378</b>	<b>0.0378</b>	<b>0.0000</b>	<b>11.3455</b>	<b>11.3455</b>	<b>0.0121</b>	<b>0.0000</b>	<b>11.5997</b>

**Mitigated**

	ROG	NOx	CO	SO2	Fugitive PM10	Exhaust PM10	PM10 Total	Fugitive PM2.5	Exhaust PM2.5	PM2.5 Total	Bio- CO2	NBio- CO2	Total CO2	CH4	N2O	CO2e
SubCategory	tons/yr										MT/yr					
Architectural Coating	3.3846						0.0000	0.0000		0.0000	0.0000	0.0000	0.0000	0.0000	0.0000	0.0000
Consumer Products	24.0057						0.0000	0.0000		0.0000	0.0000	0.0000	0.0000	0.0000	0.0000	0.0000
Hearth	0.0000	0.0000	0.0000	0.0000			0.0000	0.0000		0.0000	0.0000	0.0000	0.0000	0.0000	0.0000	0.0000
Landscaping	0.2322	0.0843	7.1148	3.7000e-004			0.0378	0.0378		0.0378	0.0378	0.0000	11.3455	11.3455	0.0121	0.0000
<b>Total</b>	<b>27.6226</b>	<b>0.0843</b>	<b>7.1148</b>	<b>3.7000e-004</b>			<b>0.0378</b>	<b>0.0378</b>		<b>0.0378</b>	<b>0.0378</b>	<b>0.0000</b>	<b>11.3455</b>	<b>11.3455</b>	<b>0.0121</b>	<b>0.0000</b>

**7.0 Water Detail**

This run is for Landscaping only.

**8.0 Waste Detail**

**8.1 Mitigation Measures Waste**

This run is for Landscaping only.

## **9.0 Operational Offroad**

---

This run is for Landscaping only.

## **10.0 Vegetation**

---

This run is for Landscaping only.

**Table GGRP-7**  
**Energy Use Emission Factors for Greenhouse Gases**  
**Oak Knoll Mixed Use Project**  
**Greenhouse Gas Reduction Plan**  
**Oakland, California**

Greenhouse Gas	CO <sub>2</sub>	CH <sub>4</sub>	N <sub>2</sub> O	CO <sub>2</sub> e	Units
<b>Global Warming Potential<sup>1</sup></b>	1	21	310	-	-
<b>2005 Electricity Use Emission Factor<sup>2</sup></b>	641 2.9E-01	0.029 1.3E-05	0.00617 2.8E-06	643.52 0.29	lb/MWh MT/MWh
<b>2020 Electricity Use Emission Factor<sup>3</sup></b>	290 1.3E-01	0.029 1.3E-05	0.00617 2.8E-06	292.52 0.13	lb/MWh MT/MWh
<b>Natural Gas Use Emission Factor<sup>4</sup></b>	117.6471 5.3E-03	0.0023 1.0E-07	0.0022 9.8E-08	118.36 0.0054	lb/MMBTU MT/therm

**Note:**

1. Global Warming Potentials from IPCC 1995 consistent with CalEEMod version 2013.2.2.
2. From CalEEMod version 2013.2.2.
3. Electricity Use CO<sub>2</sub> emission factor from PG&E 2013. The 2020 PG&E emission factor is used for operating year 2024. CH<sub>4</sub> and N<sub>2</sub>O emission factors from CalEEMod.
4. Natural Gas Use emission factors from Table 8.2 of CalEEMod User's Guide Appendix D.

1 ton= 2000 pounds  
1 short ton = 1.10231 tons  
1 MMBTU = 10 therms

**References:**

California Emissions Estimator Model (CalEEMod). Available online at <http://www.caleemod.com/>

Intergovernmental Panel on Climate Change (IPCC). 1995. Second Assessment Report.  
Available at [http://www.ipcc.ch/ipccreports/sar/wg\\_i/ipcc\\_sar\\_wg\\_i\\_full\\_report.pdf](http://www.ipcc.ch/ipccreports/sar/wg_i/ipcc_sar_wg_i_full_report.pdf)

Pacific Gas and Electric Company (PG&E). 2013. Greenhouse Gas Emission Factors: Guidance for PG&E Customers.  
Available online at  
[http://www.pge.com/includes/docs/pdfs/shared/environment/calculator/pge\\_ghg\\_emission\\_factor\\_info\\_sheet.pdf](http://www.pge.com/includes/docs/pdfs/shared/environment/calculator/pge_ghg_emission_factor_info_sheet.pdf)

**Table GGRP-8**  
**Energy Usage for 2005 BAU Operations**  
**Oak Knoll Mixed Use Project**  
**Greenhouse Gas Reduction Plan**  
**Oakland, California**

CalEEMod Land Use Type	CalEEMod Land Use Subtype	Size	Electricity Use Rate <sup>1</sup> (kWh/unit-yr)	Annual Electricity Use (MWh/yr)	Natural Gas Use Rate <sup>2</sup> (kBtu/unit-yr)	Annual Natural Gas Use (therm/yr)
Condo/Townhouse	Condo/Townhouse	572 DU	4,296	2,457	25,895	148,121
Single Family Home	Single Family Home	363 DU	7,027	2,551	56,001	203,283
Commercial	Government (Civic Center)	4,000 SF	15	58	24	944
Retail	Supermarket	66,000 SF	40	2,610	41	26,974
Recreational	Health Club	10,000 SF	9	87	27	2,696
Recreational	High Turnover (Sit Down Restaurant)	6,000 SF	31	185	171	10,253
Parking Lot	Parking Lot	87,210 SF	1	76	0	0
Parking	Parking	26 acres	0	0	0	0
City Park	City Park	84.3 acres	0	0	0	0
Electrical Vehicle Charging			-	2	-	-
<b>Project Subtotal</b>		<b>-</b>	<b>-</b>	<b>8,025</b>	<b>-</b>	<b>392,271</b>

**Notes:**

1. Electricity Use Rate is the sum of Title 24 and non-Title 24 electricity uses plus Lighting electricity use.
2. Natural Gas Use Rate is the sum of Title 24 and non-Title 24 natural gas uses.

**Table GGRP-9**  
**Energy Use Emissions, 2005 BAU Operational**  
**Oak Knoll Mixed Use Project**  
**Greenhouse Gas Reduction Plan**  
**Oakland, California**

<b>CalEEMod Land Use Type</b>	<b>CalEEMod Land Use Subtype</b>	<b>CO<sub>2</sub>e (MT CO<sub>2</sub>e/yr)</b>
Condo/Townhouse	Condo/Townhouse	1,513
Single Family Home	Single Family Home	1,836
Commercial	Government (Civic Center)	22
Retail	Supermarket	907
Recreational	Health Club	40
Recreational	High Turnover (Sit Down Restaurant)	109
Parking Lot	Parking Lot	22
Parking	Parking	0
City Park	City Park	0
Electric Vehicle Charging		1
<b>Project Subtotal</b>		<b>4,450</b>

**Table GGRP-10**  
**Water Usage and Electricity Intensity**  
**Oak Knoll Mixed Use Project**  
**Greenhouse Gas Reduction Plan**  
**Oakland, California**

**Water Usage**

**Project Total:** 207,000 gallons/day  
76 million gallons/year

**Notes:**

1. Water usage from East Bay Municipal Utilities District

**Water Electricity Intensity**

<b>County</b>	<b>Electricity to Supply Water (kWh/million gal)</b>	<b>Electricity to Treat Water (kWh/million gal)</b>	<b>Electricity to Distribute Water (kWh/million gal)</b>
Alameda	2,117	111	1,272

**Notes:**

1. Water Electricity Intensity from Table 9.2 of Appendix D of the CalEEMod User's Guide.

**Table GGRP-11**  
**Wastewater Treatment Types and Electricity Intensity**  
**Oak Knoll Mixed Use Project**  
**Greenhouse Gas Reduction Plan**  
**Oakland, California**

**Wastewater Electricity Intensity**

County	Electricity to Treat Wastewater (kWh/million gal)
Alameda	1,911

Water Electricity Intensity from Table 9.2 of Appendix D of the CalEEMod User's Guide.

**Wastewater Treatment Types**

County	Septic Tank	Aerobic	Anaerobic, Facultative Lagoons	Anaerobic, Combustion of Gas	Anaerobic, Cogeneration of Gas
Alameda	10.33%	87.46%	2.21%	100%	0%

Water Treatment Types from Table 9.3 of Appendix D of the CalEEMod User's Guide.

**Wastewater Treatment Direct Emission Factors**

Wastewater Treatment Type	CO <sub>2</sub> Biogenic, ton/gal	CO <sub>2</sub> Non-Biogenic, ton/gal	CH <sub>4</sub> , ton/gal	N <sub>2</sub> O, ton/gal
Septic	0	0	2.50E-07	8.48E-10
Aerobic	3.90E-07	0	1.34E-09	8.48E-10
Anaerobic Facultative	3.90E-07	0	4.02E-07	8.48E-10
Digester Burn	0	0	0	0
Digester Cogen	0	0	0	0

Wastewater Treatment Direct Emission Factors from Table 9.4 of Appendix D of the CalEEMod User's Guide.



**Table GGRP-12**  
**Water Use GHG Emissions, 2005 BAU**  
**Oak Knoll Mixed Use Project**  
**Greenhouse Gas Reduction Plan**  
**Oakland, California**

Electricity Indirect Emissions (MT CO <sub>2</sub> e/year)	Septic Tank Direct Emissions (MT CO <sub>2</sub> e/year)	Aerobic Direct Emissions (MT CO <sub>2</sub> e/year)	Facultative Lagoon Direct Emissions (MT CO <sub>2</sub> e/year)
119	42	44	15
<b>Total: 221</b>			

**Table GGRP-13**  
**Solid Waste Generation**  
**Oak Knoll Mixed Use Project**  
**Greenhouse Gas Reduction Plan**  
**Oakland, California**

**Solid Waste Generation Rates<sup>1</sup>**

CalEEMod Land Use Type	CalEEMod Land Use Subtype	Size Metric	Solid Waste Generation Rate, ton/size/year
Condo/Townhouse	Condo/Townhouse	DU	0.46
Single Family Home	Single Family Home	Resident	0.42
Commercial	Government (Civic Center)	1000sqft	5.70
Retail	Supermarket	1000sqft	5.64
Recreational	Health Club	1000sqft	5.70
Recreational	High Turnover (Sit Down Restaurant)	1000sqft	11.90
Parking Lot	Parking Lot	1000sqft	0
Parking	Parking	acres	0
City Park	City Park	acres	0.09

**Notes:**

1. Solid Waste Generation Rates from Table 10.1 of Appendix D of the CalEEMod User's Guide.

**Solid Waste Generation - Project Operation**

CalEEMod Land Use Type	CalEEMod Land Use Subtype	Area (DU or 1000 sq ft or acre)	Solid Waste Generation Rate, ton/year
Condo/Townhouse	Condo/Townhouse	572 DU	263
Single Family Home	Single Family Home	872 Residents	366
Commercial	Government (Civic Center)	4 KSF	23
Retail	Supermarket	66 KSF	372
Recreational	Health Club	10 KSF	57
Recreational	High Turnover (Sit Down Restaurant)	6 KSF	71
Parking Lot	Parking Lot	87 KSF	0
Parking	Parking	26 acres	0
City Park	City Park	84.3 acres	7
<b>Project Total</b>		-	<b>1,160</b>

**Table GGRP-14**  
**Solid Waste GHG Emissions Baseline and Project Operations**  
**Oak Knoll Mixed Use Project**  
**Greenhouse Gas Reduction Plan**  
**Oakland, California**

**Solid Waste Landfill Gas Treatment Types**

County	Landfill, No Gas Capture	Landfill, Capture Gas Flare	Landfill Gas Capture Efficiency	Landfill Gas Control Efficiency
Alameda	6%	94%	75%	98%

Solid Waste Landfill Gas Treatment Types from Appendices A and D, Table 10.2, to CalEEMod User's Guide

**Solid Waste Landfill Gas (LFG) Emission Factors**

Description	CO <sub>2</sub> Emissions (ton/ton waste)	CH <sub>4</sub> Emissions (ton/ton waste)
No LFG Collection	1.43E-01	4.26E-02
LFG Collection and Combustion	2.29E-01	1.14E-02

Solid Waste Landfill Gas Emission Factors from Table 10.2 of CalEEMod User's Guide Appendix D.

**Solid Waste GHG Emissions - Project Operation**

CalEEMod Land Use Type	CalEEMod Land Use Subtype	CO <sub>2</sub> (MT/year)	CH <sub>4</sub> (MT/year)	CO <sub>2</sub> e (MT/year)
Condo/Townhouse	Condo/Townhouse	53	3.2	120
Single Family Home	Single Family Home	74	4.4	167
Commercial	Government (Civic Center)	4.6	0.27	10.4
Retail	Supermarket	75.6	4.47	169.3
Recreational	Health Club	12	0.7	26
Recreational	High Turnover (Sit Down Restaurant)	14.5	0.86	32
Parking Lot	Parking Lot	0	0	0
Parking	Parking	0	0	0
City Park	City Park	1	0.1	3
<b>Project Total by GHG, without Zero Waste Goal</b>		<b>235</b>	<b>14</b>	<b>528</b>

**Table GGRP-15**  
**Operational Mobile Emissions, 2005 BAU**  
**Oak Knoll Mixed Use Project**  
**Greenhouse Gas Reduction Plan**  
**Oakland, California**

Daily One-way Vehicle Trips <sup>1</sup>	Weighted Trip Length <sup>2</sup> (mile/trip)	Miles/Day	Emissions, Total <sup>3</sup> (MT CO <sub>2</sub> e/year)
12,481	5.6	70,095	11,205

**Notes:**

1. Trip rates from Fehr & Peers traffic study. The value of 12,481 Daily One-way Vehicle Trips is a weighted average of weekday, Saturday, and Sunday trips.
2. Trip length weighted by trip length for each external land use and relative contribution to trip generation of external and internal trips.
3. Emissions include gasoline and diesel vehicle types only. Emissions from electric vehicle charging are in Table GGRP-23.

**Table GGRP-16**  
**Onroad Fleet Mix, 2005 BAU**  
**Oak Knoll Mixed Use Project**  
**Greenhouse Gas Reduction Plan**  
**Oakland, California**

Fleet Mix, 2005					
Vehicle Type	Total Vehicles	Percentage of Fleet Mix	% by Fuel Type		
			Gas	DSL	ELEC
LDA	645,402	58%	57.2%	0.3%	0.0%
LDT1	85,166	8%	7.6%	0.0%	0.0%
LDT2	177,825	16%	15.9%	0.0%	0.0%
LHD1	30,543	3%	2.0%	0.8%	0.0%
LHD2	4,807	0%	0.2%	0.2%	0.0%
MCY	23,657	2%	2.1%	0.0%	0.0%
MDV	122,377	11%	10.9%	0.0%	0.0%
MH	6,374	1%	0.5%	0.0%	0.0%
OBUS	876	0%	0.0%	0.0%	0.0%
SBUS	280	0%	0.0%	0.0%	0.0%
T6	13,563	1%	0.3%	0.9%	0.0%
T7	9,264	1%	0.0%	0.8%	0.0%
UBUS	1,347	0%	0.0%	0.1%	0.0%

**Notes:**

1. Fleet mixes calculated based on EMFAC2014 projections for Alameda County.

**Abbreviations:**

EMFAC2014: California Air Resources Board Emission FACTor model.

**Table GGRP-17**  
**Mobile Emission Factors, 2005 BAU**  
**Oak Knoll Mixed Use Project**  
**Greenhouse Gas Reduction Plan**  
**Oakland, California**

Year	Fuel	CO <sub>2</sub>	CO <sub>2</sub>
		[g/mile]	[g/trip]
2005	Total	423.2655	81.7196
2005	Diesel	37.5738	0.1226
2005	Gas	385.6917	81.5971
2005	Electric	0.0000	0.0000

**Notes:**

1. Emission factors from EMFAC2014. The g/trip emission factors were calculated by converting the g/vehicle/day emission factor in EMFAC using the following equation:

$$\text{g/trip} = (\text{g/vehicle/day}) * (\text{vehicle population/vehicle trip count})$$

**Abbreviations:**

EMFAC2014: California Air Resources Board EMISSION FACTOR model.

**Table GGRP-18**  
**Vegetation-Change Emissions**  
**Oak Knoll Mixed Use Project**  
**Greenhouse Gas Reduction Plan**  
**Oakland, California**

<b>Number of Net New Trees<sup>1</sup></b>	<b>Units</b>	<b>Broad Species Class</b>	<b>Annual CO<sub>2</sub> accumulation per tree (MT CO<sub>2</sub>/tree/year)<sup>2</sup></b>	<b>Project GHG Sequestration<sup>3</sup> (MT CO<sub>2</sub>e)</b>
909	Trees	Mixed Hardwood	-0.0367	-667
<b>Number of Net New Acres<sup>1</sup></b>	<b>Units</b>	<b>Vegetation Land Use Subtype</b>	<b>Annual CO<sub>2</sub> accumulation per acre (MT CO<sub>2</sub>/acre/year)<sup>2</sup></b>	<b>Project GHG Loss due to Land Use Change (MT CO<sub>2</sub>e)</b>
-52.40	Acres	Grassland	-4.31	226
<b>Total, Trees and Acres Covered</b>				-441
<b>Annualized Net Vegetation Emissions (over 40 years)</b>				-11

**Notes:**

1. Number of net new trees from Project Sponsor.
2. From CalEEMod User's Guide Appendix A.
3. Trees are assumed to have a growing period of 20 years.

**Table GGRP-19**  
**Public Street Lighting GHG Emissions**  
**Oak Knoll Mixed Use Project**  
**Greenhouse Gas Reduction Plan**  
**Oakland, California**

	<b>2005 BAU</b>	<b>Project</b>
<b>Parameter</b>	High Pressure Sodium (HPS) lights	Light Emitting Diode (LED) lights
Watts/hour/light <sup>1</sup>	138.32	69.21
Number of lights <sup>2</sup>	230	230
Hours/day	11.5	11.5
MWh/day	0.37	0.18
Emission Factor <sup>3</sup> (lb CO <sub>2</sub> /MWh)	641	290
lb of CO <sub>2</sub> /year	85,598	19,377
<b>MT CO<sub>2</sub> /yr</b>	<b>39</b>	<b>9</b>

**Notes:**

1. Assumes a 138.32 W HPS Type II full cut off light bulb is replaced with a 50% more efficient LED light bulb of 69.21. Light bulb comparison was obtained from the base case and LED D in LED Street Lighting Study prepared for the U.S. Department of Energy. Available at: [http://apps1.eere.energy.gov/buildings/publications/pdfs/ssl/gateway\\_sf-streetlighting.pdf](http://apps1.eere.energy.gov/buildings/publications/pdfs/ssl/gateway_sf-streetlighting.pdf). Accessed: February 2016.
2. Based on length of street in Project.
3. CO<sub>2</sub>e intensity factor for Pacific Gas and Electric accounts for CO<sub>2</sub> emissions rates under the 2020 33% Renewable Portfolio Standard in the Project scenario.

**Abbreviations:**

- Wh - watt hour
- MWh - megawatt hour
- lb - pound
- CO<sub>2</sub> - carbon dioxide
- MT - metric tonne



**Appendix P**  
Updated Mobile Air Quality  
Emissions (December 2016)

## Oak Knoll - Mobile Emissions- TDM Alameda County, Annual

### 1.0 Project Characteristics

#### 1.1 Land Usage

Land Uses	Size	Metric	Lot Acreage	Floor Surface Area	Population
Condo/Townhouse	572.00	Dwelling Unit	35.75	572,000.00	1636
Single Family Housing	363.00	Dwelling Unit	117.86	653,400.00	1038
User Defined Residential	1.00	Dwelling Unit	0.00	0.00	0
Regional Shopping Center	82.00	1000sqft	1.88	82,000.00	0

#### 1.2 Other Project Characteristics

<b>Urbanization</b>	Urban	<b>Wind Speed (m/s)</b>	2.2	<b>Precipitation Freq (Days)</b>	63
<b>Climate Zone</b>	5			<b>Operational Year</b>	2024
<b>Utility Company</b>	Pacific Gas & Electric Company				
<b>CO2 Intensity (lb/MWahr)</b>	290	<b>CH4 Intensity (lb/MWahr)</b>	0.029	<b>N2O Intensity (lb/MWahr)</b>	0.006

The "User Defined Residential" land use category is used solely for the purpose of representing internal vehicle trips.

#### 1.3 User Entered Comments & Non-Default Data

- Project Characteristics - This run is for mobile emissions only.
- Land Use - Use "User Defined Residential" to represent Internal Trips
- Construction Phase - This run is for mobile operational emissions only
- Vehicle Trips - Adjusted trip lengths to equal daily and annual project VMT.
- Woodstoves - This run is for mobile emissions only.
- Consumer Products - This run is for mobile emissions only
- Area Coating - This run is for mobile emissions only
- Landscape Equipment - This run is for mobile emissions only

Energy Use - This run is for mobile emissions only

Water And Wastewater - This run is for mobile emissions only

Solid Waste - This run is for mobile emissions only

Table Name	Column Name	Default Value	New Value
tblLandUse	Population	3.00	0.00
tblProjectCharacteristics	CO2IntensityFactor	641.35	290
tblProjectCharacteristics	OperationalYear	2014	2024
tblVehicleEF	HHD	527.63	11,915.71
tblVehicleEF	HHD	1,551.39	1,631.45
tblVehicleEF	HHD	49.32	0.80
tblVehicleEF	HHD	0.05	0.01
tblVehicleEF	HHD	3.27	36.02
tblVehicleEF	HHD	2.13	2.42
tblVehicleEF	HHD	3.88	0.02
tblVehicleEF	HHD	9.0910e-003	0.01
tblVehicleEF	HHD	0.06	0.06
tblVehicleEF	HHD	0.04	0.04
tblVehicleEF	HHD	0.07	7.6090e-003
tblVehicleEF	HHD	8.3800e-004	6.0000e-006
tblVehicleEF	HHD	8.3640e-003	0.01
tblVehicleEF	HHD	0.03	0.03
tblVehicleEF	HHD	8.7720e-003	8.9770e-003
tblVehicleEF	HHD	0.07	7.2800e-003
tblVehicleEF	HHD	7.7700e-004	6.0000e-006
tblVehicleEF	HHD	1.2500e-003	1.1600e-004
tblVehicleEF	HHD	0.08	3.3800e-004
tblVehicleEF	HHD	0.61	1.09
tblVehicleEF	HHD	8.9000e-004	8.1000e-005
tblVehicleEF	HHD	0.22	0.09
tblVehicleEF	HHD	0.40	1.4990e-003

tbIVehicleEF	HHD	1.60	5.8680e-003
tbIVehicleEF	LDA	219.18	238.69
tbIVehicleEF	LDA	48.27	54.13
tbIVehicleEF	LDA	0.54	0.58
tbIVehicleEF	LDA	0.07	0.04
tbIVehicleEF	LDA	0.07	0.07
tbIVehicleEF	LDA	1.8980e-003	1.7350e-003
tbIVehicleEF	LDA	4.2000e-003	2.2310e-003
tbIVehicleEF	LDA	1.7600e-003	1.5990e-003
tbIVehicleEF	LDA	3.8970e-003	2.0510e-003
tbIVehicleEF	LDA	0.02	0.18
tbIVehicleEF	LDA	0.07	0.10
tbIVehicleEF	LDA	0.02	0.17
tbIVehicleEF	LDA	0.01	9.0080e-003
tbIVehicleEF	LDA	0.20	0.21
tbIVehicleEF	LDA	0.08	0.07
tbIVehicleEF	LDT1	271.84	289.65
tbIVehicleEF	LDT1	59.80	66.90
tbIVehicleEF	LDT1	0.06	0.04
tbIVehicleEF	LDT1	0.16	0.09
tbIVehicleEF	LDT1	0.17	0.13
tbIVehicleEF	LDT1	2.8090e-003	2.2500e-003
tbIVehicleEF	LDT1	4.6960e-003	2.9660e-003
tbIVehicleEF	LDT1	2.6050e-003	2.0730e-003
tbIVehicleEF	LDT1	4.3570e-003	2.7270e-003
tbIVehicleEF	LDT1	0.08	0.47
tbIVehicleEF	LDT1	0.21	0.22
tbIVehicleEF	LDT1	0.08	0.42
tbIVehicleEF	LDT1	0.03	0.02
tbIVehicleEF	LDT1	0.74	0.83

tbIVehicleEF	LDT1	0.22	0.16
tbIVehicleEF	LDT2	334.46	326.25
tbIVehicleEF	LDT2	73.52	74.96
tbIVehicleEF	LDT2	0.17	0.18
tbIVehicleEF	LDT2	0.10	0.06
tbIVehicleEF	LDT2	0.13	0.10
tbIVehicleEF	LDT2	1.8300e-003	1.7300e-003
tbIVehicleEF	LDT2	4.0760e-003	2.3320e-003
tbIVehicleEF	LDT2	1.6980e-003	1.5910e-003
tbIVehicleEF	LDT2	3.7820e-003	2.1440e-003
tbIVehicleEF	LDT2	0.04	0.22
tbIVehicleEF	LDT2	0.12	0.10
tbIVehicleEF	LDT2	0.04	0.23
tbIVehicleEF	LDT2	0.02	0.01
tbIVehicleEF	LDT2	0.39	0.38
tbIVehicleEF	LDT2	0.12	0.08
tbIVehicleEF	LHD1	7.80	124.23
tbIVehicleEF	LHD1	760.22	700.56
tbIVehicleEF	LHD1	40.00	29.65
tbIVehicleEF	LHD1	0.03	0.02
tbIVehicleEF	LHD1	0.05	1.02
tbIVehicleEF	LHD1	0.81	1.09
tbIVehicleEF	LHD1	1.19	0.93
tbIVehicleEF	LHD1	5.5800e-004	0.01
tbIVehicleEF	LHD1	0.05	0.08
tbIVehicleEF	LHD1	9.1290e-003	9.9050e-003
tbIVehicleEF	LHD1	0.01	0.01
tbIVehicleEF	LHD1	6.7200e-004	8.2600e-004
tbIVehicleEF	LHD1	5.1400e-004	0.01
tbIVehicleEF	LHD1	0.02	0.03

tbIVehicleEF	LHD1	2.2820e-003	2.4760e-003
tbIVehicleEF	LHD1	0.01	0.01
tbIVehicleEF	LHD1	6.2400e-004	7.6000e-004
tbIVehicleEF	LHD1	1.8220e-003	0.03
tbIVehicleEF	LHD1	0.07	0.09
tbIVehicleEF	LHD1	0.03	0.22
tbIVehicleEF	LHD1	1.1450e-003	0.02
tbIVehicleEF	LHD1	0.10	0.11
tbIVehicleEF	LHD1	0.43	0.68
tbIVehicleEF	LHD1	0.31	0.23
tbIVehicleEF	LHD2	8.58	184.54
tbIVehicleEF	LHD2	657.39	713.08
tbIVehicleEF	LHD2	26.95	22.66
tbIVehicleEF	LHD2	4.5480e-003	4.8880e-003
tbIVehicleEF	LHD2	0.10	1.25
tbIVehicleEF	LHD2	1.16	0.66
tbIVehicleEF	LHD2	0.73	0.42
tbIVehicleEF	LHD2	1.1160e-003	0.02
tbIVehicleEF	LHD2	0.06	0.09
tbIVehicleEF	LHD2	0.01	0.01
tbIVehicleEF	LHD2	0.02	0.01
tbIVehicleEF	LHD2	3.1900e-004	3.5900e-004
tbIVehicleEF	LHD2	1.0270e-003	0.02
tbIVehicleEF	LHD2	0.03	0.04
tbIVehicleEF	LHD2	2.5360e-003	2.6610e-003
tbIVehicleEF	LHD2	0.02	0.01
tbIVehicleEF	LHD2	2.9600e-004	3.3000e-004
tbIVehicleEF	LHD2	9.8400e-004	0.01
tbIVehicleEF	LHD2	0.04	0.03
tbIVehicleEF	LHD2	0.02	0.18

tbIVehicleEF	LHD2	6.3700e-004	6.2210e-003
tbIVehicleEF	LHD2	0.09	0.10
tbIVehicleEF	LHD2	0.24	0.18
tbIVehicleEF	LHD2	0.17	0.08
tbIVehicleEF	MCY	150.64	175.14
tbIVehicleEF	MCY	37.25	45.44
tbIVehicleEF	MCY	5.6760e-003	0.03
tbIVehicleEF	MCY	1.23	1.16
tbIVehicleEF	MCY	0.32	0.32
tbIVehicleEF	MCY	0.04	0.01
tbIVehicleEF	MCY	8.0000e-003	4.0000e-003
tbIVehicleEF	MCY	2.8600e-004	2.1380e-003
tbIVehicleEF	MCY	7.7900e-004	3.7350e-003
tbIVehicleEF	MCY	0.02	5.0400e-003
tbIVehicleEF	MCY	2.0000e-003	1.0000e-003
tbIVehicleEF	MCY	2.4500e-004	1.9990e-003
tbIVehicleEF	MCY	6.6600e-004	3.5160e-003
tbIVehicleEF	MCY	0.59	1.60
tbIVehicleEF	MCY	0.35	0.73
tbIVehicleEF	MCY	0.33	0.99
tbIVehicleEF	MCY	2.67	2.31
tbIVehicleEF	MCY	1.22	2.29
tbIVehicleEF	MCY	2.23	2.24
tbIVehicleEF	MDV	447.62	441.43
tbIVehicleEF	MDV	98.69	99.76
tbIVehicleEF	MDV	0.11	0.12
tbIVehicleEF	MDV	0.20	0.12
tbIVehicleEF	MDV	0.32	0.23
tbIVehicleEF	MDV	2.0280e-003	1.8430e-003
tbIVehicleEF	MDV	4.0140e-003	2.4730e-003

tbIVehicleEF	MDV	1.8810e-003	1.6980e-003
tbIVehicleEF	MDV	3.7240e-003	2.2740e-003
tbIVehicleEF	MDV	0.07	0.34
tbIVehicleEF	MDV	0.21	0.17
tbIVehicleEF	MDV	0.07	0.37
tbIVehicleEF	MDV	0.03	0.02
tbIVehicleEF	MDV	0.64	0.55
tbIVehicleEF	MDV	0.30	0.20
tbIVehicleEF	MH	665.11	1,210.52
tbIVehicleEF	MH	28.78	59.04
tbIVehicleEF	MH	1.4000e-003	2.8770e-003
tbIVehicleEF	MH	1.03	1.19
tbIVehicleEF	MH	0.67	0.81
tbIVehicleEF	MH	0.05	0.13
tbIVehicleEF	MH	8.4680e-003	0.01
tbIVehicleEF	MH	0.02	0.02
tbIVehicleEF	MH	4.5900e-004	1.0960e-003
tbIVehicleEF	MH	0.02	0.06
tbIVehicleEF	MH	2.1170e-003	3.2080e-003
tbIVehicleEF	MH	0.02	0.02
tbIVehicleEF	MH	4.2600e-004	1.0080e-003
tbIVehicleEF	MH	0.56	0.07
tbIVehicleEF	MH	0.05	0.07
tbIVehicleEF	MH	0.24	0.03
tbIVehicleEF	MH	0.06	0.08
tbIVehicleEF	MH	1.29	1.85
tbIVehicleEF	MH	0.32	0.31
tbIVehicleEF	MHD	572.65	634.35
tbIVehicleEF	MHD	1,004.94	1,181.37
tbIVehicleEF	MHD	49.32	8.39



tbIVehicleEF	MHD	0.02	0.02
tbIVehicleEF	MHD	3.33	1.75
tbIVehicleEF	MHD	0.99	1.17
tbIVehicleEF	MHD	1.43	0.12
tbIVehicleEF	MHD	7.6380e-003	4.3000e-004
tbIVehicleEF	MHD	0.12	0.13
tbIVehicleEF	MHD	0.01	0.01
tbIVehicleEF	MHD	0.03	3.4490e-003
tbIVehicleEF	MHD	1.0610e-003	1.1800e-004
tbIVehicleEF	MHD	7.0270e-003	4.3000e-004
tbIVehicleEF	MHD	0.05	0.06
tbIVehicleEF	MHD	2.8910e-003	3.0000e-003
tbIVehicleEF	MHD	0.03	3.2970e-003
tbIVehicleEF	MHD	9.8500e-004	1.0800e-004
tbIVehicleEF	MHD	1.5750e-003	2.3530e-003
tbIVehicleEF	MHD	0.08	6.2090e-003
tbIVehicleEF	MHD	0.18	0.07
tbIVehicleEF	MHD	9.7900e-004	1.4000e-003
tbIVehicleEF	MHD	0.11	0.04
tbIVehicleEF	MHD	0.44	0.03
tbIVehicleEF	MHD	0.76	0.05
tbIVehicleEF	OBUS	533.48	360.48
tbIVehicleEF	OBUS	1,045.10	1,236.90
tbIVehicleEF	OBUS	32.73	73.47
tbIVehicleEF	OBUS	1.8110e-003	6.4500e-004
tbIVehicleEF	OBUS	3.20	0.05
tbIVehicleEF	OBUS	1.12	0.23
tbIVehicleEF	OBUS	1.18	1.01
tbIVehicleEF	OBUS	8.7920e-003	0.00
tbIVehicleEF	OBUS	0.10	0.13

tbIVehicleEF	OBUS	0.01	0.01
tbIVehicleEF	OBUS	0.03	1.2150e-003
tbIVehicleEF	OBUS	4.5100e-004	9.6600e-004
tbIVehicleEF	OBUS	8.0890e-003	0.00
tbIVehicleEF	OBUS	0.04	0.06
tbIVehicleEF	OBUS	2.6290e-003	3.0000e-003
tbIVehicleEF	OBUS	0.03	1.1180e-003
tbIVehicleEF	OBUS	4.1900e-004	8.8800e-004
tbIVehicleEF	OBUS	6.8200e-004	0.03
tbIVehicleEF	OBUS	0.03	0.02
tbIVehicleEF	OBUS	0.56	0.58
tbIVehicleEF	OBUS	3.4900e-004	0.01
tbIVehicleEF	OBUS	0.12	0.03
tbIVehicleEF	OBUS	0.31	0.23
tbIVehicleEF	OBUS	0.52	0.37
tbIVehicleEF	SBUS	556.14	3,069.02
tbIVehicleEF	SBUS	966.46	972.23
tbIVehicleEF	SBUS	115.30	59.57
tbIVehicleEF	SBUS	1.8900e-004	2.9800e-004
tbIVehicleEF	SBUS	7.12	18.35
tbIVehicleEF	SBUS	5.53	2.79
tbIVehicleEF	SBUS	2.38	0.60
tbIVehicleEF	SBUS	0.01	0.02
tbIVehicleEF	SBUS	0.47	0.74
tbIVehicleEF	SBUS	0.01	0.01
tbIVehicleEF	SBUS	0.04	0.02
tbIVehicleEF	SBUS	3.0800e-003	1.0670e-003
tbIVehicleEF	SBUS	0.01	0.02
tbIVehicleEF	SBUS	0.20	0.32
tbIVehicleEF	SBUS	2.6090e-003	2.5110e-003

tbIVehicleEF	SBUS	0.03	0.01
tbIVehicleEF	SBUS	2.8580e-003	9.8200e-004
tbIVehicleEF	SBUS	0.02	9.4560e-003
tbIVehicleEF	SBUS	0.19	0.03
tbIVehicleEF	SBUS	0.10	4.13
tbIVehicleEF	SBUS	8.0390e-003	4.6030e-003
tbIVehicleEF	SBUS	0.26	0.09
tbIVehicleEF	SBUS	2.54	0.17
tbIVehicleEF	SBUS	1.49	0.43
tbIVehicleEF	UBUS	2,139.09	2,188.84
tbIVehicleEF	UBUS	9.91	79.76
tbIVehicleEF	UBUS	3.5990e-003	5.9600e-004
tbIVehicleEF	UBUS	13.62	14.46
tbIVehicleEF	UBUS	0.63	1.01
tbIVehicleEF	UBUS	0.78	0.65
tbIVehicleEF	UBUS	8.0000e-003	0.01
tbIVehicleEF	UBUS	0.23	0.30
tbIVehicleEF	UBUS	2.1800e-004	9.3300e-004
tbIVehicleEF	UBUS	0.34	0.28
tbIVehicleEF	UBUS	2.0000e-003	3.0000e-003
tbIVehicleEF	UBUS	0.21	0.28
tbIVehicleEF	UBUS	2.0200e-004	8.5800e-004
tbIVehicleEF	UBUS	1.6400e-003	9.2990e-003
tbIVehicleEF	UBUS	0.04	0.05
tbIVehicleEF	UBUS	7.8000e-004	4.6680e-003
tbIVehicleEF	UBUS	0.60	0.74
tbIVehicleEF	UBUS	0.39	0.47
tbIVehicleEF	UBUS	0.37	0.57
tbIVehicleTrips	CC_TL	0.00	6.50
tbIVehicleTrips	CC_TL	7.30	6.50

tblVehicleTrips	CC_TL	0.00	6.50
tblVehicleTrips	CNW_TL	0.00	5.70
tblVehicleTrips	CNW_TL	7.30	5.70
tblVehicleTrips	CNW_TL	0.00	5.70
tblVehicleTrips	CW_TL	0.00	11.00
tblVehicleTrips	CW_TL	9.50	11.00
tblVehicleTrips	CW_TL	0.00	11.00
tblVehicleTrips	DV_TP	11.00	0.00
tblVehicleTrips	DV_TP	11.00	0.00
tblVehicleTrips	HO_TL	5.40	6.50
tblVehicleTrips	HO_TL	0.00	5.70
tblVehicleTrips	HO_TL	5.40	6.50
tblVehicleTrips	HO_TL	5.40	0.00
tblVehicleTrips	HO_TTP	44.80	0.00
tblVehicleTrips	HS_TL	4.30	6.50
tblVehicleTrips	HS_TL	0.00	6.50
tblVehicleTrips	HS_TL	4.30	6.50
tblVehicleTrips	HS_TL	4.30	0.00
tblVehicleTrips	HS_TTP	29.10	0.00
tblVehicleTrips	HW_TL	12.40	11.00
tblVehicleTrips	HW_TL	0.00	11.00
tblVehicleTrips	HW_TL	12.40	11.00
tblVehicleTrips	HW_TL	12.40	0.50
tblVehicleTrips	HW_TTP	26.10	100.00
tblVehicleTrips	PB_TP	3.00	0.00
tblVehicleTrips	PB_TP	3.00	0.00
tblVehicleTrips	PR_TP	86.00	100.00
tblVehicleTrips	PR_TP	86.00	100.00
tblVehicleTrips	PR_TP	0.00	100.00
tblVehicleTrips	ST_TR	7.16	4.37

tblVehicleTrips	ST_TR	49.97	76.31
tblVehicleTrips	ST_TR	10.08	7.66
tblVehicleTrips	ST_TR	0.00	1,303.58
tblVehicleTrips	SU_TR	6.07	3.72
tblVehicleTrips	SU_TR	25.24	51.49
tblVehicleTrips	SU_TR	8.77	6.63
tblVehicleTrips	SU_TR	0.00	992.72
tblVehicleTrips	WD_TR	6.59	4.45
tblVehicleTrips	WD_TR	42.94	56.01
tblVehicleTrips	WD_TR	9.57	7.33
tblVehicleTrips	WD_TR	0.00	1,113.05

## 2.0 Emissions Summary

	ROG	NOx	CO	SO2	Fugitive PM10	Exhaust PM10	PM10 Total	Fugitive PM2.5	Exhaust PM2.5	PM2.5 Total	Bio- CO2	NBio-CO2	Total CO2	CH4	N2O	CO2e
Percent Reduction	0.00	0.00	0.00	0.00	0.00	0.00	0.00	0.00	0.00	0.00	0.00	0.00	0.00	0.00	0.00	0.00

## 2.2 Overall Operational

### Unmitigated Operational

	ROG	NOx	CO	SO2	Fugitive PM10	Exhaust PM10	PM10 Total	Fugitive PM2.5	Exhaust PM2.5	PM2.5 Total	Bio- CO2	NBio-CO2	Total CO2	CH4	N2O	CO2e
Category	tons/yr										MT/yr					
Mobile	6.9344	6.9333	48.7282	0.1111	8.2228	0.0702	8.2931	2.1985	0.0654	2.2639	0.0000	8,174.5843	8,174.5843	0.2537	0.0000	8,179.9117

### Mitigated Operational

	ROG	NOx	CO	SO2	Fugitive PM10	Exhaust PM10	PM10 Total	Fugitive PM2.5	Exhaust PM2.5	PM2.5 Total	Bio- CO2	NBio-CO2	Total CO2	CH4	N2O	CO2e
Category	tons/yr										MT/yr					
Mobile	6.9344	6.9333	48.7282	0.1111	8.2228	0.0702	8.2931	2.1985	0.0654	2.2639	0.0000	8,174.5843	8,174.5843	0.2537	0.0000	8,179.9117

	ROG	NOx	CO	SO2	Fugitive PM10	Exhaust PM10	PM10 Total	Fugitive PM2.5	Exhaust PM2.5	PM2.5 Total	Bio- CO2	NBio-CO2	Total CO2	CH4	N2O	CO2e
Percent Reduction	0.00	0.00	0.00	0.00	0.00	0.00	0.00	0.00	0.00	0.00	0.00	0.00	0.00	0.00	0.00	0.00

### 3.0 Construction Detail

This run is for mobile emissions only.

### 4.0 Operational Detail - Mobile

#### 4.1 Mitigation Measures Mobile

	ROG	NOx	CO	SO2	Fugitive PM10	Exhaust PM10	PM10 Total	Fugitive PM2.5	Exhaust PM2.5	PM2.5 Total	Bio- CO2	NBio-CO2	Total CO2	CH4	N2O	CO2e
Category	tons/yr										MT/yr					
Mitigated	6.9344	6.9333	48.7282	0.1111	8.2228	0.0702	8.2931	2.1985	0.0654	2.2639	0.0000	8,174.5843	8,174.5843	0.2537	0.0000	8,179.9117
Unmitigated	6.9344	6.9333	48.7282	0.1111	8.2228	0.0702	8.2931	2.1985	0.0654	2.2639	0.0000	8,174.5843	8,174.5843	0.2537	0.0000	8,179.9117

#### 4.2 Trip Summary Information

Land Use	Average Daily Trip Rate			Unmitigated	Mitigated
	Weekday	Saturday	Sunday	Annual VMT	Annual VMT

Condo/Townhouse	2,545.40	2,499.64	2127.84	6,925,722	6,925,722
Regional Shopping Center	4,592.82	6,257.42	4222.18	7,746,944	7,746,944
Single Family Housing	2,660.79	2,780.58	2406.69	7,379,365	7,379,365
User Defined Residential	1,113.05	1,303.58	992.72	204,400	204,400
<b>Total</b>	<b>10,912.06</b>	<b>12,841.22</b>	<b>9,749.43</b>	<b>22,256,431</b>	<b>22,256,431</b>

### 4.3 Trip Type Information

Land Use	Miles			Trip %			Trip Purpose %		
	H-W or C-W	H-S or C-C	H-O or C-NW	H-W or C-	H-S or C-C	H-O or C-NW	Primary	Diverted	Pass-by
Condo/Townhouse	11.00	6.50	6.50	26.10	29.10	44.80	100	0	0
Regional Shopping Center	11.00	6.50	5.70	16.30	64.70	19.00	54	35	11
Single Family Housing	11.00	6.50	6.50	26.10	29.10	44.80	100	0	0
User Defined Residential	0.50	0.00	0.00	100.00	0.00	0.00	100	0	0

LDA	LDT1	LDT2	MDV	LHD1	LHD2	MHD	HHD	OBUS	UBUS	MCY	SBUS	MH
0.576024	0.040328	0.182594	0.117261	0.017100	0.004888	0.017957	0.012200	0.000645	0.000596	0.026636	0.000298	0.002877

### 5.0 Energy Detail

This run is for mobile emissions only.

### 6.0 Area Detail

This run is for mobile emissions only.

### 7.0 Water Detail

This run is for mobile emissions only.

### 8.0 Waste Detail

This run is for mobile emissions only.

## **9.0 Operational Offroad**

---

This run is for mobile emissions only.

## **10.0 Vegetation**

---

This run is for mobile emissions only.



## Oak Knoll - Mobile Emissions- no TDM Alameda County, Annual

### 1.0 Project Characteristics

#### 1.1 Land Usage

Land Uses	Size	Metric	Lot Acreage	Floor Surface Area	Population
Condo/Townhouse	572.00	Dwelling Unit	35.75	572,000.00	1636
Single Family Housing	363.00	Dwelling Unit	117.86	653,400.00	1038
User Defined Residential	1.00	Dwelling Unit	0.00	0.00	0
Regional Shopping Center	82.00	1000sqft	1.88	82,000.00	0

#### 1.2 Other Project Characteristics

<b>Urbanization</b>	Urban	<b>Wind Speed (m/s)</b>	2.2	<b>Precipitation Freq (Days)</b>	63
<b>Climate Zone</b>	5			<b>Operational Year</b>	2024
<b>Utility Company</b>	Pacific Gas & Electric Company				
<b>CO2 Intensity (lb/MWahr)</b>	290	<b>CH4 Intensity (lb/MWahr)</b>	0.029	<b>N2O Intensity (lb/MWahr)</b>	0.006

The "User Defined Residential" land use category is used solely for the purpose of representing internal vehicle trips.

#### 1.3 User Entered Comments & Non-Default Data

- Project Characteristics - This run is for mobile emissions only.
- Land Use - Use "User Defined Residential" to represent Internal Trips
- Construction Phase - This run is for mobile operational emissions only
- Vehicle Trips - Adjusted trip lengths to equal daily and annual project VMT.
- Woodstoves - This run is for mobile emissions only.
- Consumer Products - This run is for mobile emissions only
- Area Coating - This run is for mobile emissions only
- Landscape Equipment - This run is for mobile emissions only

Energy Use - This run is for mobile emissions only

Water And Wastewater - This run is for mobile emissions only

Solid Waste - This run is for mobile emissions only

Table Name	Column Name	Default Value	New Value
tblLandUse	Population	3.00	0.00
tblProjectCharacteristics	CO2IntensityFactor	641.35	290
tblProjectCharacteristics	OperationalYear	2014	2024
tblVehicleEF	HHD	527.63	11,915.71
tblVehicleEF	HHD	1,551.39	1,631.45
tblVehicleEF	HHD	49.32	0.80
tblVehicleEF	HHD	0.05	0.01
tblVehicleEF	HHD	3.27	36.02
tblVehicleEF	HHD	2.13	2.42
tblVehicleEF	HHD	3.88	0.02
tblVehicleEF	HHD	9.0910e-003	0.01
tblVehicleEF	HHD	0.06	0.06
tblVehicleEF	HHD	0.04	0.04
tblVehicleEF	HHD	0.07	7.6090e-003
tblVehicleEF	HHD	8.3800e-004	6.0000e-006
tblVehicleEF	HHD	8.3640e-003	0.01
tblVehicleEF	HHD	0.03	0.03
tblVehicleEF	HHD	8.7720e-003	8.9770e-003
tblVehicleEF	HHD	0.07	7.2800e-003
tblVehicleEF	HHD	7.7700e-004	6.0000e-006
tblVehicleEF	HHD	1.2500e-003	1.1600e-004
tblVehicleEF	HHD	0.08	3.3800e-004
tblVehicleEF	HHD	0.61	1.09
tblVehicleEF	HHD	8.9000e-004	8.1000e-005
tblVehicleEF	HHD	0.22	0.09
tblVehicleEF	HHD	0.40	1.4990e-003

tbIVehicleEF	HHD	1.60	5.8680e-003
tbIVehicleEF	LDA	219.18	238.69
tbIVehicleEF	LDA	48.27	54.13
tbIVehicleEF	LDA	0.54	0.58
tbIVehicleEF	LDA	0.07	0.04
tbIVehicleEF	LDA	0.07	0.07
tbIVehicleEF	LDA	1.8980e-003	1.7350e-003
tbIVehicleEF	LDA	4.2000e-003	2.2310e-003
tbIVehicleEF	LDA	1.7600e-003	1.5990e-003
tbIVehicleEF	LDA	3.8970e-003	2.0510e-003
tbIVehicleEF	LDA	0.02	0.18
tbIVehicleEF	LDA	0.07	0.10
tbIVehicleEF	LDA	0.02	0.17
tbIVehicleEF	LDA	0.01	9.0080e-003
tbIVehicleEF	LDA	0.20	0.21
tbIVehicleEF	LDA	0.08	0.07
tbIVehicleEF	LDT1	271.84	289.65
tbIVehicleEF	LDT1	59.80	66.90
tbIVehicleEF	LDT1	0.06	0.04
tbIVehicleEF	LDT1	0.16	0.09
tbIVehicleEF	LDT1	0.17	0.13
tbIVehicleEF	LDT1	2.8090e-003	2.2500e-003
tbIVehicleEF	LDT1	4.6960e-003	2.9660e-003
tbIVehicleEF	LDT1	2.6050e-003	2.0730e-003
tbIVehicleEF	LDT1	4.3570e-003	2.7270e-003
tbIVehicleEF	LDT1	0.08	0.47
tbIVehicleEF	LDT1	0.21	0.22
tbIVehicleEF	LDT1	0.08	0.42
tbIVehicleEF	LDT1	0.03	0.02
tbIVehicleEF	LDT1	0.74	0.83

tbIVehicleEF	LDT1	0.22	0.16
tbIVehicleEF	LDT2	334.46	326.25
tbIVehicleEF	LDT2	73.52	74.96
tbIVehicleEF	LDT2	0.17	0.18
tbIVehicleEF	LDT2	0.10	0.06
tbIVehicleEF	LDT2	0.13	0.10
tbIVehicleEF	LDT2	1.8300e-003	1.7300e-003
tbIVehicleEF	LDT2	4.0760e-003	2.3320e-003
tbIVehicleEF	LDT2	1.6980e-003	1.5910e-003
tbIVehicleEF	LDT2	3.7820e-003	2.1440e-003
tbIVehicleEF	LDT2	0.04	0.22
tbIVehicleEF	LDT2	0.12	0.10
tbIVehicleEF	LDT2	0.04	0.23
tbIVehicleEF	LDT2	0.02	0.01
tbIVehicleEF	LDT2	0.39	0.38
tbIVehicleEF	LDT2	0.12	0.08
tbIVehicleEF	LHD1	7.80	124.23
tbIVehicleEF	LHD1	760.22	700.56
tbIVehicleEF	LHD1	40.00	29.65
tbIVehicleEF	LHD1	0.03	0.02
tbIVehicleEF	LHD1	0.05	1.02
tbIVehicleEF	LHD1	0.81	1.09
tbIVehicleEF	LHD1	1.19	0.93
tbIVehicleEF	LHD1	5.5800e-004	0.01
tbIVehicleEF	LHD1	0.05	0.08
tbIVehicleEF	LHD1	9.1290e-003	9.9050e-003
tbIVehicleEF	LHD1	0.01	0.01
tbIVehicleEF	LHD1	6.7200e-004	8.2600e-004
tbIVehicleEF	LHD1	5.1400e-004	0.01
tbIVehicleEF	LHD1	0.02	0.03

tbIVehicleEF	LHD1	2.2820e-003	2.4760e-003
tbIVehicleEF	LHD1	0.01	0.01
tbIVehicleEF	LHD1	6.2400e-004	7.6000e-004
tbIVehicleEF	LHD1	1.8220e-003	0.03
tbIVehicleEF	LHD1	0.07	0.09
tbIVehicleEF	LHD1	0.03	0.22
tbIVehicleEF	LHD1	1.1450e-003	0.02
tbIVehicleEF	LHD1	0.10	0.11
tbIVehicleEF	LHD1	0.43	0.68
tbIVehicleEF	LHD1	0.31	0.23
tbIVehicleEF	LHD2	8.58	184.54
tbIVehicleEF	LHD2	657.39	713.08
tbIVehicleEF	LHD2	26.95	22.66
tbIVehicleEF	LHD2	4.5480e-003	4.8880e-003
tbIVehicleEF	LHD2	0.10	1.25
tbIVehicleEF	LHD2	1.16	0.66
tbIVehicleEF	LHD2	0.73	0.42
tbIVehicleEF	LHD2	1.1160e-003	0.02
tbIVehicleEF	LHD2	0.06	0.09
tbIVehicleEF	LHD2	0.01	0.01
tbIVehicleEF	LHD2	0.02	0.01
tbIVehicleEF	LHD2	3.1900e-004	3.5900e-004
tbIVehicleEF	LHD2	1.0270e-003	0.02
tbIVehicleEF	LHD2	0.03	0.04
tbIVehicleEF	LHD2	2.5360e-003	2.6610e-003
tbIVehicleEF	LHD2	0.02	0.01
tbIVehicleEF	LHD2	2.9600e-004	3.3000e-004
tbIVehicleEF	LHD2	9.8400e-004	0.01
tbIVehicleEF	LHD2	0.04	0.03
tbIVehicleEF	LHD2	0.02	0.18

tbIVehicleEF	LHD2	6.3700e-004	6.2210e-003
tbIVehicleEF	LHD2	0.09	0.10
tbIVehicleEF	LHD2	0.24	0.18
tbIVehicleEF	LHD2	0.17	0.08
tbIVehicleEF	MCY	150.64	175.14
tbIVehicleEF	MCY	37.25	45.44
tbIVehicleEF	MCY	5.6760e-003	0.03
tbIVehicleEF	MCY	1.23	1.16
tbIVehicleEF	MCY	0.32	0.32
tbIVehicleEF	MCY	0.04	0.01
tbIVehicleEF	MCY	8.0000e-003	4.0000e-003
tbIVehicleEF	MCY	2.8600e-004	2.1380e-003
tbIVehicleEF	MCY	7.7900e-004	3.7350e-003
tbIVehicleEF	MCY	0.02	5.0400e-003
tbIVehicleEF	MCY	2.0000e-003	1.0000e-003
tbIVehicleEF	MCY	2.4500e-004	1.9990e-003
tbIVehicleEF	MCY	6.6600e-004	3.5160e-003
tbIVehicleEF	MCY	0.59	1.60
tbIVehicleEF	MCY	0.35	0.73
tbIVehicleEF	MCY	0.33	0.99
tbIVehicleEF	MCY	2.67	2.31
tbIVehicleEF	MCY	1.22	2.29
tbIVehicleEF	MCY	2.23	2.24
tbIVehicleEF	MDV	447.62	441.43
tbIVehicleEF	MDV	98.69	99.76
tbIVehicleEF	MDV	0.11	0.12
tbIVehicleEF	MDV	0.20	0.12
tbIVehicleEF	MDV	0.32	0.23
tbIVehicleEF	MDV	2.0280e-003	1.8430e-003
tbIVehicleEF	MDV	4.0140e-003	2.4730e-003

tbIVehicleEF	MDV	1.8810e-003	1.6980e-003
tbIVehicleEF	MDV	3.7240e-003	2.2740e-003
tbIVehicleEF	MDV	0.07	0.34
tbIVehicleEF	MDV	0.21	0.17
tbIVehicleEF	MDV	0.07	0.37
tbIVehicleEF	MDV	0.03	0.02
tbIVehicleEF	MDV	0.64	0.55
tbIVehicleEF	MDV	0.30	0.20
tbIVehicleEF	MH	665.11	1,210.52
tbIVehicleEF	MH	28.78	59.04
tbIVehicleEF	MH	1.4000e-003	2.8770e-003
tbIVehicleEF	MH	1.03	1.19
tbIVehicleEF	MH	0.67	0.81
tbIVehicleEF	MH	0.05	0.13
tbIVehicleEF	MH	8.4680e-003	0.01
tbIVehicleEF	MH	0.02	0.02
tbIVehicleEF	MH	4.5900e-004	1.0960e-003
tbIVehicleEF	MH	0.02	0.06
tbIVehicleEF	MH	2.1170e-003	3.2080e-003
tbIVehicleEF	MH	0.02	0.02
tbIVehicleEF	MH	4.2600e-004	1.0080e-003
tbIVehicleEF	MH	0.56	0.07
tbIVehicleEF	MH	0.05	0.07
tbIVehicleEF	MH	0.24	0.03
tbIVehicleEF	MH	0.06	0.08
tbIVehicleEF	MH	1.29	1.85
tbIVehicleEF	MH	0.32	0.31
tbIVehicleEF	MHD	572.65	634.35
tbIVehicleEF	MHD	1,004.94	1,181.37
tbIVehicleEF	MHD	49.32	8.39

tbIVehicleEF	MHD	0.02	0.02
tbIVehicleEF	MHD	3.33	1.75
tbIVehicleEF	MHD	0.99	1.17
tbIVehicleEF	MHD	1.43	0.12
tbIVehicleEF	MHD	7.6380e-003	4.3000e-004
tbIVehicleEF	MHD	0.12	0.13
tbIVehicleEF	MHD	0.01	0.01
tbIVehicleEF	MHD	0.03	3.4490e-003
tbIVehicleEF	MHD	1.0610e-003	1.1800e-004
tbIVehicleEF	MHD	7.0270e-003	4.3000e-004
tbIVehicleEF	MHD	0.05	0.06
tbIVehicleEF	MHD	2.8910e-003	3.0000e-003
tbIVehicleEF	MHD	0.03	3.2970e-003
tbIVehicleEF	MHD	9.8500e-004	1.0800e-004
tbIVehicleEF	MHD	1.5750e-003	2.3530e-003
tbIVehicleEF	MHD	0.08	6.2090e-003
tbIVehicleEF	MHD	0.18	0.07
tbIVehicleEF	MHD	9.7900e-004	1.4000e-003
tbIVehicleEF	MHD	0.11	0.04
tbIVehicleEF	MHD	0.44	0.03
tbIVehicleEF	MHD	0.76	0.05
tbIVehicleEF	OBUS	533.48	360.48
tbIVehicleEF	OBUS	1,045.10	1,236.90
tbIVehicleEF	OBUS	32.73	73.47
tbIVehicleEF	OBUS	1.8110e-003	6.4500e-004
tbIVehicleEF	OBUS	3.20	0.05
tbIVehicleEF	OBUS	1.12	0.23
tbIVehicleEF	OBUS	1.18	1.01
tbIVehicleEF	OBUS	8.7920e-003	0.00
tbIVehicleEF	OBUS	0.10	0.13



tbIVehicleEF	OBUS	0.01	0.01
tbIVehicleEF	OBUS	0.03	1.2150e-003
tbIVehicleEF	OBUS	4.5100e-004	9.6600e-004
tbIVehicleEF	OBUS	8.0890e-003	0.00
tbIVehicleEF	OBUS	0.04	0.06
tbIVehicleEF	OBUS	2.6290e-003	3.0000e-003
tbIVehicleEF	OBUS	0.03	1.1180e-003
tbIVehicleEF	OBUS	4.1900e-004	8.8800e-004
tbIVehicleEF	OBUS	6.8200e-004	0.03
tbIVehicleEF	OBUS	0.03	0.02
tbIVehicleEF	OBUS	0.56	0.58
tbIVehicleEF	OBUS	3.4900e-004	0.01
tbIVehicleEF	OBUS	0.12	0.03
tbIVehicleEF	OBUS	0.31	0.23
tbIVehicleEF	OBUS	0.52	0.37
tbIVehicleEF	SBUS	556.14	3,069.02
tbIVehicleEF	SBUS	966.46	972.23
tbIVehicleEF	SBUS	115.30	59.57
tbIVehicleEF	SBUS	1.8900e-004	2.9800e-004
tbIVehicleEF	SBUS	7.12	18.35
tbIVehicleEF	SBUS	5.53	2.79
tbIVehicleEF	SBUS	2.38	0.60
tbIVehicleEF	SBUS	0.01	0.02
tbIVehicleEF	SBUS	0.47	0.74
tbIVehicleEF	SBUS	0.01	0.01
tbIVehicleEF	SBUS	0.04	0.02
tbIVehicleEF	SBUS	3.0800e-003	1.0670e-003
tbIVehicleEF	SBUS	0.01	0.02
tbIVehicleEF	SBUS	0.20	0.32
tbIVehicleEF	SBUS	2.6090e-003	2.5110e-003

tbIVehicleEF	SBUS	0.03	0.01
tbIVehicleEF	SBUS	2.8580e-003	9.8200e-004
tbIVehicleEF	SBUS	0.02	9.4560e-003
tbIVehicleEF	SBUS	0.19	0.03
tbIVehicleEF	SBUS	0.10	4.13
tbIVehicleEF	SBUS	8.0390e-003	4.6030e-003
tbIVehicleEF	SBUS	0.26	0.09
tbIVehicleEF	SBUS	2.54	0.17
tbIVehicleEF	SBUS	1.49	0.43
tbIVehicleEF	UBUS	2,139.09	2,188.84
tbIVehicleEF	UBUS	9.91	79.76
tbIVehicleEF	UBUS	3.5990e-003	5.9600e-004
tbIVehicleEF	UBUS	13.62	14.46
tbIVehicleEF	UBUS	0.63	1.01
tbIVehicleEF	UBUS	0.78	0.65
tbIVehicleEF	UBUS	8.0000e-003	0.01
tbIVehicleEF	UBUS	0.23	0.30
tbIVehicleEF	UBUS	2.1800e-004	9.3300e-004
tbIVehicleEF	UBUS	0.34	0.28
tbIVehicleEF	UBUS	2.0000e-003	3.0000e-003
tbIVehicleEF	UBUS	0.21	0.28
tbIVehicleEF	UBUS	2.0200e-004	8.5800e-004
tbIVehicleEF	UBUS	1.6400e-003	9.2990e-003
tbIVehicleEF	UBUS	0.04	0.05
tbIVehicleEF	UBUS	7.8000e-004	4.6680e-003
tbIVehicleEF	UBUS	0.60	0.74
tbIVehicleEF	UBUS	0.39	0.47
tbIVehicleEF	UBUS	0.37	0.57
tbIVehicleTrips	CC_TL	0.00	6.50
tbIVehicleTrips	CC_TL	7.30	6.50

tblVehicleTrips	CC_TL	0.00	6.50
tblVehicleTrips	CNW_TL	0.00	5.70
tblVehicleTrips	CNW_TL	7.30	5.70
tblVehicleTrips	CNW_TL	0.00	5.70
tblVehicleTrips	CW_TL	0.00	11.00
tblVehicleTrips	CW_TL	9.50	11.00
tblVehicleTrips	CW_TL	0.00	11.00
tblVehicleTrips	DV_TP	11.00	0.00
tblVehicleTrips	DV_TP	11.00	0.00
tblVehicleTrips	HO_TL	5.40	6.50
tblVehicleTrips	HO_TL	0.00	5.70
tblVehicleTrips	HO_TL	5.40	6.50
tblVehicleTrips	HO_TL	5.40	0.00
tblVehicleTrips	HO_TTP	44.80	0.00
tblVehicleTrips	HS_TL	4.30	6.50
tblVehicleTrips	HS_TL	0.00	6.50
tblVehicleTrips	HS_TL	4.30	6.50
tblVehicleTrips	HS_TL	4.30	0.00
tblVehicleTrips	HS_TTP	29.10	0.00
tblVehicleTrips	HW_TL	12.40	11.00
tblVehicleTrips	HW_TL	0.00	11.00
tblVehicleTrips	HW_TL	12.40	11.00
tblVehicleTrips	HW_TL	12.40	0.50
tblVehicleTrips	HW_TTP	26.10	100.00
tblVehicleTrips	PB_TP	3.00	0.00
tblVehicleTrips	PB_TP	3.00	0.00
tblVehicleTrips	PR_TP	86.00	100.00
tblVehicleTrips	PR_TP	86.00	100.00
tblVehicleTrips	PR_TP	0.00	100.00
tblVehicleTrips	ST_TR	7.16	5.02

tblVehicleTrips	ST_TR	49.97	87.93
tblVehicleTrips	ST_TR	10.08	8.79
tblVehicleTrips	ST_TR	0.00	1,303.58
tblVehicleTrips	SU_TR	6.07	4.28
tblVehicleTrips	SU_TR	25.24	59.31
tblVehicleTrips	SU_TR	8.77	7.63
tblVehicleTrips	SU_TR	0.00	992.72
tblVehicleTrips	WD_TR	6.59	5.14
tblVehicleTrips	WD_TR	42.94	64.45
tblVehicleTrips	WD_TR	9.57	8.44
tblVehicleTrips	WD_TR	0.00	1,113.05

## 2.0 Emissions Summary

	ROG	NOx	CO	SO2	Fugitive PM10	Exhaust PM10	PM10 Total	Fugitive PM2.5	Exhaust PM2.5	PM2.5 Total	Bio- CO2	NBio-CO2	Total CO2	CH4	N2O	CO2e
Percent Reduction	0.00	0.00	0.00	0.00	0.00	0.00	0.00	0.00	0.00	0.00	0.00	0.00	0.00	0.00	0.00	0.00

## 2.2 Overall Operational

### Unmitigated Operational

	ROG	NOx	CO	SO2	Fugitive PM10	Exhaust PM10	PM10 Total	Fugitive PM2.5	Exhaust PM2.5	PM2.5 Total	Bio- CO2	NBio-CO2	Total CO2	CH4	N2O	CO2e
Category	tons/yr										MT/yr					
Mobile	7.9057	7.9371	55.8595	0.1277	9.4595	0.0806	9.5401	2.5291	0.0751	2.6042	0.0000	9,391.3010	9,391.3010	0.2914	0.0000	9,397.4209

### Mitigated Operational

	ROG	NOx	CO	SO2	Fugitive PM10	Exhaust PM10	PM10 Total	Fugitive PM2.5	Exhaust PM2.5	PM2.5 Total	Bio- CO2	NBio-CO2	Total CO2	CH4	N2O	CO2e
Category	tons/yr										MT/yr					
Mobile	7.9057	7.9371	55.8595	0.1277	9.4595	0.0806	9.5401	2.5291	0.0751	2.6042	0.0000	9,391.3010	9,391.3010	0.2914	0.0000	9,397.4209

	ROG	NOx	CO	SO2	Fugitive PM10	Exhaust PM10	PM10 Total	Fugitive PM2.5	Exhaust PM2.5	PM2.5 Total	Bio- CO2	NBio-CO2	Total CO2	CH4	N2O	CO2e
Percent Reduction	0.00	0.00	0.00	0.00	0.00	0.00	0.00	0.00	0.00	0.00	0.00	0.00	0.00	0.00	0.00	0.00

### 3.0 Construction Detail

This run is for mobile emissions only.

### 4.0 Operational Detail - Mobile

#### 4.1 Mitigation Measures Mobile

	ROG	NOx	CO	SO2	Fugitive PM10	Exhaust PM10	PM10 Total	Fugitive PM2.5	Exhaust PM2.5	PM2.5 Total	Bio- CO2	NBio-CO2	Total CO2	CH4	N2O	CO2e
Category	tons/yr										MT/yr					
Mitigated	7.9057	7.9371	55.8595	0.1277	9.4595	0.0806	9.5401	2.5291	0.0751	2.6042	0.0000	9,391.3010	9,391.3010	0.2914	0.0000	9,397.4209
Unmitigated	7.9057	7.9371	55.8595	0.1277	9.4595	0.0806	9.5401	2.5291	0.0751	2.6042	0.0000	9,391.3010	9,391.3010	0.2914	0.0000	9,397.4209

#### 4.2 Trip Summary Information

Land Use	Average Daily Trip Rate			Unmitigated	Mitigated
	Weekday	Saturday	Sunday	Annual VMT	Annual VMT

Condo/Townhouse	2,940.08	2,871.44	2448.16	7,989,461	7,989,461
Regional Shopping Center	5,284.90	7,210.26	4863.42	8,917,770	8,917,770
Single Family Housing	3,063.72	3,190.77	2769.69	8,491,920	8,491,920
User Defined Residential	1,113.05	1,303.58	992.72	204,400	204,400
<b>Total</b>	<b>12,401.75</b>	<b>14,576.05</b>	<b>11,073.99</b>	<b>25,603,552</b>	<b>25,603,552</b>

### 4.3 Trip Type Information

Land Use	Miles			Trip %			Trip Purpose %		
	H-W or C-W	H-S or C-C	H-O or C-NW	H-W or C-	H-S or C-C	H-O or C-NW	Primary	Diverted	Pass-by
Condo/Townhouse	11.00	6.50	6.50	26.10	29.10	44.80	100	0	0
Regional Shopping Center	11.00	6.50	5.70	16.30	64.70	19.00	54	35	11
Single Family Housing	11.00	6.50	6.50	26.10	29.10	44.80	100	0	0
User Defined Residential	0.50	0.00	0.00	100.00	0.00	0.00	100	0	0

LDA	LDT1	LDT2	MDV	LHD1	LHD2	MHD	HHD	OBUS	UBUS	MCY	SBUS	MH
0.576024	0.040328	0.182594	0.117261	0.017100	0.004888	0.017957	0.012200	0.000645	0.000596	0.026636	0.000298	0.002877

### 5.0 Energy Detail

This run is for mobile emissions only.

### 6.0 Area Detail

This run is for mobile emissions only.

### 7.0 Water Detail

This run is for mobile emissions only.

### 8.0 Waste Detail

This run is for mobile emissions only.

## **9.0 Operational Offroad**

---

This run is for mobile emissions only.

## **10.0 Vegetation**

---

This run is for mobile emissions only.

**Appendix Q**  
Attachments to Letter M  
Exhibits A and C



FINAL DRAFT REPORT

**Annual report for the East Bay Regional Park District  
Grassland Monitoring Project  
2009 Field Season (Year 8)**

**Principal Investigators:** Professors James W. Bartolome and Reginald H. Barrett  
**Co-Investigators:** Peter Hopkinson, Michele Hammond, Naomi Schowalter, Luke Macaulay, Sheri Spiegall, Rebecca Wenk

**Summary**

*Introduction*

In its eighth year, the Grassland Monitoring Project continues to develop and implement improved quantitative monitoring methods to determine the response of Park District grassland communities to management. The focus of the project is on the Valley grassland community in four Park District units: Morgan Territory, Pleasanton Ridge, Sunol-Ohlone, and Vasco Caves. Valley grassland is the East Bay's and the District's most extensive grassland vegetation type and has high bird conservation value.

Following the collection of baseline data, the project has intensified its focus on native plant and grassland bird diversity in the Valley grassland and the effects of livestock grazing on this diversity. We have begun to elucidate the effects of grazing compared to no grazing on native plants and birds, which will be expanded as we gather further years of data.

Although many of the general relationships among plants, animals, and environment are known for the Valley grassland, information from previous research and experience is not sufficient to predict the effects of management reliably. Better descriptions of the spatial and temporal variation in grassland communities combined with an understanding of the relationships between vegetation structure and animal abundance will help guide reliable and informed management decisions.

*Vegetation monitoring overview*

Annual rainfall amount and pattern wield enormous control over Valley grassland vegetation; species composition, diversity, dominance relationships, and production all vary significantly with annual rainfall. The first several years of the project saw average or above-average rainfall. The last three years 2007-2009, however, were drought years, and, consequently, the project now has much-needed data on the response of the Valley Grassland community to drought.

Consistent with previous years, species cover distribution in 2009 was highly skewed to a few dominant species. Of the 100 species observed in 2009, the three most abundant species, wild oats (*Avena fatua*), broadleaf filaree (*Erodium botrys*), and annual ryegrass (*Lolium multiflorum*), all non-native species, made up almost 40% of the total relative cover. Total species richness for 2009 was 100 species. Fifty percent of the species were native, and 50% were non-native. Of the 50 native species, 60% were annual forbs, 28% were perennial forbs, and 10% were perennial grasses.

FINAL DRAFT REPORT

Rainfall appears to be the primary driver of native species richness and native cover, with high rainfall years producing greater cover and richness than low rainfall years. Livestock grazing may exert some influence on diversity metrics, however, even at the landscape level.

California's Valley grassland typically has low cover of native species. Consistent with this generalization, absolute native cover at the study sites has been low, fluctuating between 3 – 7% depending on year. Averaged over all sites, native cover appears to track rainfall amount and pattern: 2005 was a wet year, and native cover was notably high; in contrast, 2007's very dry weather was the likely cause of the lowest native cover observed during the project's run. Although 2008 and 2009 were also drought years, native cover was greater in both years than 2007's low.

When categorized by grazing status, annual native cover fluctuates differently within each park from 2005 to 2009. Morgan Territory's grazed plots declined in native cover in 2007 and 2008 compared to 2006 and had less native cover than its ungrazed plots in both 2007 and 2008; Morgan Territory's ungrazed plots increased slightly in native cover over the same period. However, this trend was reversed in 2009: grazed plots increased in native cover, overtaking ungrazed plots, which declined in native cover. Trends at Vasco Caves were complicated by a 2006 wildfire that burnt some of the ungrazed plots. In 2009, on Vasco Caves' grazed plots, there was a return to a more moderate level of native cover; ungrazed plots at Vasco Caves also experienced a decline in native cover in 2009. At Sunol, both grazed and ungrazed plots decreased in native cover from 2005 to 2007 but increased in 2008. Ungrazed plots at Sunol decreased once again in native cover in 2009, but grazed plots experienced a dramatic increase. Grazed plots had much greater native cover than ungrazed plots in all years at Sunol. Comparing parks over the last four years, there was no consistent trend in native cover and grazing status.

Native species richness (the number of native species in a location) is an important metric in the Valley grassland. In Valley grassland, non-native species typically make up more than 90% of the cover. Species richness, in contrast, is more evenly distributed between native and non-native species. Like native cover, native species richness generally appears to track annual weather patterns and not management regimes. Average native species richness on all cattle-grazed plots in 2009 was greater than on ungrazed plots or on sheep-grazed plots. In the non-drought years of 2003 to 2006, grazed plots generally exhibited higher native richness than ungrazed plots, and at the landscape level, grazing appeared to maintain higher native species richness. However, in the last three years of drought, this relationship became more complicated. The drought/grazing interaction is complex, with weather, site, and grazing factors playing roles. Even in the three drought years, grazed plots had greater native species richness than ungrazed sites in almost all comparisons.

As noted in previous reports, the bunchgrass Purple needlegrass (*Nassella pulchra*) has exhibited a steady decline over the course of the project; purple needlegrass is the most abundant native species in our study plots. This decline in Purple needlegrass has occurred in all parks and on grazed and ungrazed plots leading us to surmise that the decline was related to regional environmental factors rather than management activities. In 2008, this decline slowed somewhat; however, in 2009, annual average cover of Purple needlegrass dropped once again. This decrease in Purple needlegrass cover occurred at all parks sampled in 2009 except for Pleasanton Ridge. Fluctuations in Purple needlegrass cover appear to be driven primarily by regional environmental factors with livestock grazing exerting little influence. The installation of additional grazed and ungrazed plots at Vasco Caves should help confirm or refute this hypothesis over the next few years.

## FINAL DRAFT REPORT

Purple false-brome (*Brachypodium distachyon*), a non-native grass, may be spreading on EBRPD properties. Since 2003, it has been observed on over 50% of the study plots; of the four parks sampled in 2009, only at Vasco Caves were there no purple false-brome observations. Unfortunately, no information about management control of this grass has been found.

In 2009, we found one species rated as “high” in the California Invasive Plant Council’s Invasive Plant Inventory (Cal-IPC 2006): Medusahead (*Taeniatherum caput-medusae*). Implementing a control program may inhibit the spread of medusahead. Because we did not survey the invasive-species-rich Brushy Peak, Chabot Ridge, and Sycamore Valley in 2008 and 2009, the number of invasive species observed in the last two years is lower than in earlier years of this study.

### *Avian monitoring overview*

The monitoring project has completed a baseline inventory of common grassland birds on park district Valley grassland and continues to focus on the effect of livestock grazing on grassland bird diversity and abundance. Point count surveys are conducted on the same grassland monitoring plots as the vegetation plots within areas that are livestock grazed and ungrazed.

On plot avian detection rates remain fairly constant and show no obvious temporal trends over the years of the study, 2004-2009. Plot detection rates are counted as the total number of individual birds on plot (within 100m of center) added cumulatively over three surveys per breeding season. In spite of the differences in climate, 2007-2008 had below average rainfall, there is no obvious trend showing climatic effects on median avian plot detection rates over all the parks and years.

Sunol-Ohlone continues to have the highest overall park avian species richness while Vasco Caves remains the lowest. This trend is also reflected in the cumulative park avian species richness within the 2004-2009 Breeding Bird Status table.

A continuing focus of the grassland bird monitoring project is to look at the grassland-specialist species that are commonly found on plot. Our grassland bird guild, Grasshopper Sparrow, Horned Lark, Savannah Sparrow, and Western Meadowlark, were chosen for their status as species of conservation and management concern and well known preference for breeding within park district grassland habitat. Comparing all the parks over 2004-2009, this grassland bird guild has a patchy distribution with low numbers of detection. None of the parks has a consistent yearly presence of all four of the guild species. For the guild, median plot detection rates are heavily weighted by the number of zeros, or plots with no birds detected. Vasco Caves is the only park where individuals from the guild are consistently found on a majority of the plots.

Our dataset does not show significant population trends for any of the guild species, because the four species are at very low numbers throughout all the parks. Our most ubiquitous grassland species, the Western Meadowlark, has a downward trend throughout the study with the 2nd lowest number of observations in 2009. Savannah Sparrows also showed a downward trend, dropping to zero detections in 2008 but reappearing with small numbers on plot in 2009. Horned Larks, our second most abundant guild species, are remaining more or less consistent in their number of total detections per year. Grasshopper Sparrows are also remaining consistent with their low numbers of total detection rates per year. Overall the grassland bird guild remains a low density community, present in some areas and consistently absent from other locations within these parks. Future analyses looking at landscape scale factors like grassland patch size,

## FINAL DRAFT REPORT

alongwith land-use history, current management, and other grassland habitat characteristics may help to explain the grassland bird distribution within the park district.

### *Previous work*

Previous reports have detailed 1) grassland insect abundance and diversity (2008 report); 2) small mammal relationships with soil, vegetation and livestock grazing (2007 report); 3) mid-project review (2006 report); and 4) considerations for the development of a grassland vegetation monitoring program (2005 report).

To date, the project has resulted in one doctoral dissertation (2007), two master’s theses (2004, 2008), an undergraduate senior thesis (2008), three scientific journal articles (2007, 2008, 2009), and a conference proceedings article (2008) (see Appendix A for details). An article on the habitat associations of grassland birds will be submitted for publication in early 2011, and work is progressing on an article evaluating the spatial and temporal variability of the East Bay grasslands.

The rich EBRPD dataset has also proven essential to the development of new ecological models and hypotheses about the Valley grassland. Four book chapters have been informed by these models and hypotheses, including chapters in two important recent reviews of California grasslands: *Terrestrial vegetation of California*, 3<sup>rd</sup> edition and *California grasslands: ecology and management* (Bartolome et al. 2007, Huntsinger et al. 2007, Jackson and Bartolome 2007).

We have made 44 presentations about Project findings and methodology at public agency meetings and scientific conferences, including in 2009, a presentation at the California Society for Ecological Restoration and California Native Grasslands Association Joint Conference (see Appendix B for further details).

**Table of contents**

**1.0** Introduction.....6  
**2.0** Study location.....6  
**3.0** Field survey methods.....6  
**4.0** Interannual vegetation changes using new interannual subset.....8  
**5.0** Purple needlegrass dynamics.....17  
**6.0** Native annual and perennial forbs and grazing status .....18  
**7.0** Purple false-brome watch .....22  
**8.0** Invasive species listed by the California Invasive Plant Council .....24  
**9.0** 2008/2009 precipitation data from the Livermore weather station .....24  
**10.0** Bird sampling 2009.....27  
**11.0** Grassland bird focal species overview.....29  
**12.0** References.....36  
**Appendix A:** Published and unpublished work from the East Bay Regional Park District  
 Grassland Monitoring Project.....38  
**Appendix B:** Oral presentations and posters from the East Bay Regional Park District  
 Grassland Monitoring Project.....43  
**Appendix C:** Former interannual subset of plots (2003-2007) .....47

**1.0 Introduction**

In its eighth year, the Grassland Monitoring Project continues to develop and implement improved quantitative monitoring methods to determine the response of Park District grassland communities to management. The focus of the project is on the Valley grassland community in four Park District units: Morgan Territory, Pleasanton Ridge, Sunol-Ohlone, and Vasco Caves. Valley grassland is the East Bay’s and the District’s most extensive grassland vegetation type and has high bird conservation value.

Following the collection of baseline data, the project has intensified its focus on native plant and grassland bird diversity in the Valley grassland and the effects of livestock grazing on this diversity. We have begun to elucidate the effects of grazing compared to no grazing on native plants and birds, which will be expanded as we gather further years of data.

Although many of the general relationships among plants, animals, and environment are known for the Valley grassland, information from previous research and experience is not sufficient to predict the effects of management reliably. Better descriptions of the spatial and temporal variation in grassland communities combined with an understanding of the relationships between vegetation structure and animal abundance will help guide reliable and informed management decisions.

Annual rainfall amount and pattern wield enormous control over Valley grassland vegetation; species composition, diversity, dominance relationships, and production all vary significantly with annual rainfall. The first several years of the project saw average or above-average rainfall. The last three years 2007-2009, however, were drought years, and, consequently, the project now has much-needed data on the response of the Valley Grassland community to drought.

**2.0 Study location**

In 2009, fifty-one vegetation plots were sampled in four parks: Morgan Territory, Pleasanton Ridge, Sunol-Ohlone, and Vasco Caves. Recent additions to the study include three plots in Vasco Caves, added in 2008 to improve our ability to discern grazing effects on native plants, in particular the important native bunchgrass Purple needlegrass (*Nassella pulchra*). The three new Vasco Cave plots contain substantial cover of Purple needlegrass; two of the plots are not grazed, and the third is grazed.

This year, three plots on Valpe Ridge and High Valley in Sunol/Ohlone were sampled for the first time. The plots are fenced to exclude livestock grazing and will provide valuable data on the effects of grazing as compared to grazing removal on the high diversity and cover of native forbs found at Valpe Ridge and High Valley.

**3.0 Field survey methods**

A plot is a location where plant species composition is measured in the spring. We use a permanent plot system in which percent cover and spatial patterning of plant species are measured along the same four line-point transects in each plot over multiple years. Permanent sampling plots were established in selected Park District properties starting in 2002 and 2003, with additional plots sited in subsequent years.

## FINAL DRAFT REPORT

Bird activity is measured using point count surveys conducted with the same central point as the vegetation plots. Other vertebrate wildlife activity is sampled through counts of animal sign along the vegetation transects. Environmental and management variables including physical site characteristics, soil properties, weather, and livestock grazing are also determined for each plot.

### 3.1 Plot locations

Sample plots were randomly located within a stratified design. The strata depended upon the specific park but were generally based on pre-existing management areas. For example, plots at Pleasanton Ridge were randomly chosen from areas already subjected to sheep grazing or cattle grazing. A majority of plots are located a minimum of 300 meters from shrub or forest habitat (greater than 30% canopy cover of shrubs or trees) so as to limit the study to grassland wildlife species.

### 3.2 Plot design and vegetation sampling (species cover and plant height)

Each plot comprises four 17-m vegetation transects radiating in the 4 cardinal directions from a central, permanently marked centroid (Bonham 1988). This radial design allows integration of a standard bird and mammal monitoring protocol with the vegetation monitoring. From a vertical line dropped perpendicular to the transect line, first-hit plant species and height are recorded every 10 cm for the first 4.5 m and every 50 cm from 5 to 17 m, for a total of 70 points per transect and 280 total per plot. In addition, 2 photos are taken of each transect: 1 from the centroid out to the end of the transect and another from the end of the transect in to the centroid (8 photos per plot).

### 3.3 Bird surveys

Variable circular plot point count surveys (Ralph et al. 1995) are conducted to measure and compare avian species composition, breeding status, richness, and diversity across parks and management regimes (treatments). Three visits are made at least ten days apart during the spring breeding season, March 31 - June 15. The center of the 100 m radius plots is the same centroid used for vegetation sampling. Distance from the center of the plot is noted for each individual in 10-meter intervals up to 100 meters and then at greater than 100 meters. Individuals flying over the plot are also recorded. Special note is made of any breeding activity observed (e.g., active nest, carrying nesting material). Counts are not conducted in conditions of excessive wind, fog, or rain.

### 3.4 Other vertebrate wildlife surveys

During both the vegetation sampling and bird surveys, careful note is taken of any presence or sign of other vertebrate wildlife.

Vegetation sampling includes the documentation of all signs of non-avian vertebrates along the four transects. Attempts are made to identify to species and quantify the various scat, runways, trails, and holes within one meter on either side of each transect. Any sightings of vertebrates during vegetation sampling are noted within the 17-meter radius plots and in the park

## FINAL DRAFT REPORT

at large. The point count surveys include the documentation of non-avian vertebrates, with notation of location within the 100 meter radius plot and in the park.

### 3.5 Environmental variables

Using a Global Positioning System unit, we determined the coordinates for each plot's centroid. These location data were overlaid on a USGS 10-meter Digital Elevation Modal (DEM) obtained from the USGS Bay Area Regional Database. The DEM generated the following topographical variables: percent slope, elevation, and aspect. We converted aspect into a linear proxy, heatload (McCune and Grace 2002, pp. 22, 24).

Weather data are downloaded on an annual basis from the NOAA weather station in Livermore. Data obtained are 1) monthly precipitation for the July to June "rain-years" over the life of the Project and 2) monthly precipitation averaged over the 30-year period, 1971-2000, for comparison with individual rain-years.

Soil samples were collected in 2002, 2003, and 2006 (full Valley grassland plot dataset). One 10 cm deep soil sample was taken adjacent to each of the four transects of a plot, and transect soil measurements were averaged for overall plot values. The UC Davis DANR Lab conducted the soil analyses. Soil properties evaluated include cation exchange capacity (CEC), and percent sand, silt, and clay. Soil chemistry measurements include nitrogen (NH<sub>4</sub> and NO<sub>3</sub>), carbon, phosphorus, and pH.

Results of soil analyses are briefly discussed in the 2006 annual report and more fully in Gea-Izquierdo et al. (2007).

### 4.0 Interannual vegetation changes using new interannual subset

In reports prior to 2008, for year to year comparisons, we used the Valley grassland "interannual subset" of parks and plots, which consisted of data for 40 plots in 6 parks from 2003 onwards (see Appendix C for a list of the former interannual subset plots), but did not include data from the nine plots in Sunol/Ohlone (added in 2005) nor the ten new plots added in 2005 and 2006 to Morgan Territory and Vasco Caves. Starting in 2008, we created a new interannual subset of plots to compare interannual variation for a more complete group of plots. Because of site/time dependency, it is important to follow the same plots over time. Consequently, we excluded data from 2002-2004 because these years did not include a substantial number of the plots. Brushy Peak, Chabot Ridge, and Sycamore Valley were no longer included in the interannual subset because these parks were not sampled after 2007.

The new interannual comparison dataset comprises all data from 2005 through the present year at four parks, Morgan Territory, Pleasanton Ridge, Sunol/Ohlone, and Vasco Caves, with the exception of the three new plots added at Vasco Caves in 2008 and the three new plots added at Sunol/Ohlone in 2009, for a total of 45 plots (Table 4.1). The three Vasco Caves plots were deliberately located in areas of high native cover and so skew year-to-year comparisons; these plots are used in the Purple needlegrass analyses, however. The three Sunol/Ohlone plots have not been included in the 2009 analyses to allow for a year of transitioning from grazed to ungrazed status.

Note that three plots in Pleasanton Ridge previously grazed by cattle were left ungrazed in 2009 (PR4-6). This change in management status should be kept in mind when evaluating

FINAL DRAFT REPORT

interannual changes on these three plots. In the following analyses, we treated the 2009 data from these plots as grazed because we assumed that a single year of grazing removal was not likely to have resulted in significant changes on the plots.

**Table 4.1:** New “interannual subset” of 45 plots

Morgan Territory		Grazing status	Pleasanton Ridge	Grazing status	Sunol/Ohlone	Grazing status
2005	2006-2009		2005-2009		2005-2009	
MT1	MT1	Ungrazed	PR4	*Cattle grazed	SU1	Cattle grazed
MT2	MT2	Ungrazed	PR5	*Cattle grazed	SU2	Cattle grazed
MT3	MT3	Ungrazed	PR6	*Cattle grazed	SU3	Cattle grazed
MT4	MT4	Cattle grazed	PR7	Sheep grazed	SU4	Cattle grazed
MT5	MT5	Cattle grazed	PR8	Sheep grazed	SU5	Cattle grazed
MT6	MT6	Cattle grazed	PR9	Sheep grazed	SU6	Cattle grazed
MT7	MT7	Cattle grazed	*Pleasanton Ridge cattle grazed plots not grazed in 2009		SU7	Ungrazed
MT8	MT8	Cattle grazed			SU8	Ungrazed
MT9	MT9	Ungrazed			SU9	Ungrazed
MT10	MT10	Ungrazed				
	MT11	Ungrazed				
	MT12	Ungrazed				
	MT13	Ungrazed				
	MT14	Cattle grazed				
	MT15	Cattle grazed				
	MT16	Cattle grazed				

Vasco Caves	Grazing status	Vasco Caves	Grazing status
2005		2006-2009	
VC1	Sheep grazed	VC1	Sheep grazed
VC2	Sheep grazed	VC2	Sheep grazed
VC3	Sheep grazed	VC3	Sheep grazed
VC4	Ungrazed	VC4	Ungrazed
VC5	Ungrazed	VC5	Ungrazed
VC6	Ungrazed	VC6	Ungrazed
VC7	Sheep grazed	VC7	Sheep grazed
VC8	Sheep grazed	VC8	Sheep grazed
VC9	Sheep grazed	VC9	Sheep grazed
VC10	Ungrazed	VC10	Ungrazed
VC11	Cattle grazed	VC11	Sheep grazed
VC12	Cattle grazed	VC12	Sheep grazed
VC13	Cattle grazed	VC13	Sheep grazed
VC14	Cattle grazed	VC14	Sheep grazed

FINAL DRAFT REPORT

4.1 Native cover by management type

Variation in Valley grassland species composition and dominance relationships is driven primarily by a complex combination of abiotic factors: annual rainfall and temperature patterns, soil chemistry and texture, and topographic characteristics such as elevation, aspect, and slope. At any given location, each year’s rainfall pattern and temperature in winter and spring largely determines which plants germinate, grow, and reproduce that year. Management activities have fairly limited influence on long-term and landscape-level changes in the grassland (Bartolome et al. 2007).

California’s Valley grassland typically has low cover of native species (Bartolome et al. 2007). Consistent with this generalization, absolute native cover at the study sites has been low, fluctuating between 3 – 7% depending on year (Table 4.2). Averaged over all sites, native cover appears to track rainfall amount and pattern: 2005 was a wet year, and native cover was notably high; in contrast, 2007’s very dry weather was the likely cause of the lowest native cover observed during the project’s run. Although 2008 and 2009 were also drought years, native cover was greater in both years than 2007’s low.

**Table 4.2:** Percent absolute cover of native plant species, 2005-2009 (new interannual subset)

Percent native cover				
2005	2006	2007	2008	2009
6.9	4.2	2.8	4.3	5.2

2007 was the first significant drought year (64% of normal rainfall) to occur during the course of the project. In the 2007 annual report, we noted that there appeared to be an interaction between grazing and annual rainfall pattern. From 2003 to 2006, grazed and ungrazed plots showed the same general native cover trajectory, likely in response to annual weather patterns; overlaying the general, weather-related trajectory, there was also an apparent management-related response: grazed plots consistently had higher native cover than ungrazed plots. In 2007, however, this management-related response changed: native cover increased from 2006 levels on ungrazed plots but declined on grazed plots (Table 4.3), and, in several instances, ungrazed plots had higher levels of native cover than grazed plots for the first time during the course of the project.

2008 was also a drought year (73% of normal rainfall), but the drought/grazing interaction did not appear as strong as in the previous year. Both grazed and ungrazed plots increased in native cover compared to 2007. Ungrazed plots increased to a greater extent than cattle-grazed plots, however, and, in fact, reached their greatest level of native cover over the five-year period (Table 4.3). Intriguingly, sheep-grazed plots also showed a much larger increase in native cover than cattle-grazed plots and sported their greatest native cover over the five-year period. For the sheep-grazed plots, this trend was driven by a significant increase in Purple needlegrass (*Nassella pulchra*) cover at Vasco Caves. Pleasanton Ridge is the only other park with sheep-grazed plots, and those plots had almost no native cover in 2008.

2009 was the third consecutive drought year (74% of normal rainfall). Compared to 2008, absolute native cover on cattle-grazed plots doubled in 2009, approaching native cover levels seen in 2005, a year notable for abundant native forbs. Concurrently, sheep-grazed and

ungrazed plots both showed a decline in native cover, sheep-grazed plots decreasing most sharply. This decrease in native cover on sheep-grazed plots can be attributed to the decline of Purple needlegrass (*Nassella pulchra*) cover at Vasco Caves (see Section 5.0). Pleasanton Ridge, the only other park with sheep grazing, increased in native cover on sheep-grazed plots in 2009.

Over the past five years, fluctuation in native cover has been about twice as large on cattle-grazed and sheep-grazed plots as it has been on ungrazed plots. The coefficient of variation for native cover, 2005-2009, is 39% for cattle-grazed plots, 45% for sheep-grazed plots, and 22% for ungrazed plots.

**Table 4.3:** Percent absolute cover of native species, 2005-2009, comparing combined cattle-grazed, sheep-grazed, and ungrazed plots (new interannual subset)

Grazing status	Percent absolute native cover				
	2005	2006	2007	2008	2009
*cattle grazed	11.6	7.3	4.7	5.0	10.0
sheep grazed	3.7	3.0	1.2	4.9	2.5
ungrazed	2.1	1.6	2.1	2.9	2.1

\*PR4-6 not grazed in 2009 but grouped with cattle grazed plots

Table 4.4 shows the annual changes in native cover within each park from 2005 to 2009, categorized by grazing status. As has been noted in previous annual reports, parks often exhibit significant differences not only in native cover levels but in trend as well. Morgan Territory's grazed plots have declined in native cover since 2006 and had less native cover than its ungrazed plots in both 2007 and 2008; Morgan Territory's ungrazed plots increased slightly in native cover over the same period. However, this trend was reversed in 2009: grazed plots increased in native cover, overtaking ungrazed plots, which declined in native cover.

Vasco Caves' grazed plots increased substantially in native cover in 2008 compared to 2007, while its ungrazed plots decreased slightly in 2008. The decrease in 2007 followed by the increase in 2008 of native cover on Vasco Caves' grazed plots may have been an artifact of the fire that occurred in June 2006 and which burned three of the grazed plots. This hypothesis is supported by the return to a more moderate level of native cover on Vasco Caves' grazed plots in 2009, though ungrazed, unburned plots at Vasco Caves also experienced a decline in native cover in 2009.

At Sunol, both grazed and ungrazed plots decreased in native cover from 2005 to 2007 but increased in 2008. Ungrazed plots at Sunol again decreased in native cover in 2009, but grazed plots experienced a dramatic increase. Grazed plots had much greater native cover than ungrazed plots in all years at Sunol.

**Table 4.4:** Average native percent relative cover for management type within park, 2005-2009 (new interannual subset)

site	plot	grazing status	native percent relative cover				
			2005	2006	2007	2008	2009
MT (2005)	1-3, 9-10	ungrazed	1.5				
MT (2005)	4-8	cattle	8.4				
MT	1-3, 9-13	ungrazed		1.4	1.6	2.1	1.3
MT	4-8, 14-16	cattle		3.6	1.0	1.1	2.4
PR	4-6	cattle	8.2	5.8	3.8	4.6	10.1*
PR	7-9	sheep	1.0	0.9	0.4	0.4	1.1
SU	7-9	ungrazed	0.5	0.2	0.1	1.5	0.9
SU	1-6	cattle	24.6	16.9	12.3	13.7	24.3
VC (2005)	1-3, 7-9	sheep	6.5				
VC (2005)	11-14	cattle	4.0				
VC	4-6, 10	ungrazed	4.5	4.0	7.8	7.3	6.1
VC	1-3, 7-9, 11-14	sheep		4.3	1.9	7.4	3.4

\*PR4-6 not grazed in 2009

#### 4.2 Native species richness by management type

Native species richness (the number of native species in a location) is an important native species metric in the Valley grassland. As noted in the previous sub-section, native cover is generally low in Valley grassland: non-native species typically make up more than 90% of the cover. Species richness, in contrast, is more evenly distributed between native and non-native species. Like native cover, however, native species richness appears to track annual weather patterns (Table 4.5). In wet years like 2005, native species richness was greater than in drought years like 2007.

**Table 4.5:** Average annual native species richness, 2005-2009 (new interannual subset)

Average annual native species richness				
2005	2006	2007	2008	2009
4.0	3.5	2.3	2.8	3.2

In 2009, average native species richness on all cattle-grazed plots (5.8) was greater than on ungrazed plots (1.1) or on sheep-grazed plots (2.2). The difference between cattle-grazed and ungrazed plots was highly statistically significant (p-value=0.002; 2-tailed t-test with unequal variance). The difference between sheep-grazed plots and ungrazed plots was not statistically significant (p-value=0.26; 2-tailed t-test with unequal variance).

In the non-drought years of 2003 to 2006, grazed plots generally exhibited higher native richness than ungrazed plots, and at the landscape level, grazing appeared to maintain higher

FINAL DRAFT REPORT

native species richness (see Section 6.3 of 2006 Report). However, in the last three years of drought, this relationship became more complicated. The drought/grazing interaction is complex, with weather, site, and grazing factors playing roles.

Even in the three drought years, grazed plots had greater native species richness than ungrazed sites in all but 2 instances: Vasco Caves in 2007 and Morgan Territory in 2008 (Table 4.6). However, in drought years, trajectories were sometimes different between grazed and ungrazed plots. Interestingly, Morgan Territory and Sunol/Ohlone plots exhibited similar patterns, while Vasco Caves differed from the other two parks.

In the two former parks, native species richness in both grazed and ungrazed plots fell in the first and most severe drought year, 2007 (64% of normal rainfall). 2008, the second year of drought (73% of normal rainfall) saw an increase in ungrazed species richness but a small continued decrease in grazed species richness. In 2009, the third consecutive year of drought (74% of normal rainfall), species richness fell on ungrazed plots but rose on grazed plots, in the case of Sunol to higher levels than in any other year (Table 4.6).

In contrast, at Vasco Caves, ungrazed plots' native species richness actually rose in 2007; grazed plots' species richness fell. The following year, both grazed and ungrazed plots increased, only to decrease in tandem again in 2009 (Table 4.6).

As noted, these drought/grazing interactions are complex, with weather, site factors (e.g., soil, topography), and grazing status potentially playing interacting roles in determining native species richness in any given year. The functional group identity of the dominant native species may also play a part, as the native vegetation at Morgan Territory and Sunol/Ohlone is dominated by forbs, while at Vasco Caves, Purple needlegrass, a bunchgrass, is the native dominant.

Type of grazing animal could also have had an effect: Sunol/Ohlone and Morgan Territory are cattle-grazed and Vasco Caves is sheep-grazed. In Pleasanton Ridge, which is both sheep- and cattle-grazed, cattle-grazed plots followed trajectories similar to Sunol/Ohlone and Morgan Territory's cattle-grazed plots, while sheep-grazed plots followed trajectories similar to Vasco Caves' sheep-grazed plots (Table 4.6). Note, however, that Pleasanton Ridge cattle-grazed plots were not grazed in 2009.

FINAL DRAFT REPORT

**Table 4.6:** 2005-2009 average native species richness by grazing status within park (new interannual subset); unknown species not included in analysis

site	plots	grazing status	average native species richness					
			2005	2006	2007	2008	2009	
MT (2005)	1-3, 9-10	ungrazed	2.4					
MT (2005)	4-8	cattle	5.8					
MT	1-3, 9-13	ungrazed		1.5	1.3	1.8	1.4	
MT	4-8, 14-16	cattle		5.3	2.0	1.8	2.3	
PR	4-6	cattle	4.7	3.7	3.3	2.3	4.7*	
PR	7-9	sheep	1.0	1.0	0.3	1.0	1.0	
SU	7-9	ungrazed	0.7	0.7	0.3	1.0	0.7	
SU	1-6	cattle	9.7	8.5	7.7	7.5	11	
VC (2005)	1-3, 7-9	sheep	3.2					
VC (2005)	11-14	cattle	1.8					
VC	4-6, 10	ungrazed	3.3	1.0	1.5	2.3	1.0	
VC	1-3, 7-9, 11-14	sheep		3.1	1.4	3.1	2.6	

\*PR4-6 not grazed in 2009

4.3 Management implications

Rainfall appears to be the primary driver of native species richness and native cover, with high rainfall years producing greater cover and richness than low rainfall years. Livestock grazing may exert some influence on these diversity metrics, however, even at the landscape level. In years with average or above-average rainfall, grazed plots have higher levels of native cover and richness than ungrazed plots, at some sites and at the landscape-scale. In drought years, livestock grazing may be associated with a reduction in native cover and species richness, but the data suggest that this effect is transient.

In 2009, the 3<sup>rd</sup> year of drought, native cover and species richness generally made a strong recovery, with cattle-grazed plots achieving the 2<sup>nd</sup> highest level of cover observed from 2005-2009. Ungrazed plots also returned to pre-drought levels of native cover, although cattle-grazed plots had much higher cover levels (Table 4.3). Sheep-grazed plots fluctuated in native cover and species richness to such an extent over the 3 drought years that no clear conclusion is possible. Fully teasing apart the effects of grazing and drought will require further investigation.

It will be instructive to observe the effects of a high rainfall year following the drought years to see whether native abundance relationships and trends revert back to their non-drought year patterns.

FINAL DRAFT REPORT

4.4 Species composition (interannual subset)

Consistent with previous years, species cover distribution in 2009 was highly skewed to a few dominant species (Tables 4.7 and 4.8). Of the 100 species observed in 2009, the three most abundant species, wild oats (*Avena fatua*), broadleaf filaree (*Erodium botrys*), and annual ryegrass (*Lolium multiflorum*), made up 39% of the total relative cover. The 13 species with an individual relative cover of  $\geq 1\%$  made up 88% of the total relative cover as a group, and the bottom 50% of the species had  $\leq 0.07\%$  cover individually and, combined, made up only 1.3% of the total relative cover.

Total species richness for 2009 was 100 species. Fifty percent of the species (50 of 100) were native, and 50% were non-native (50 of 100). Of the 50 native species, 60% (30 of 50) were annual forbs, 28% (14 of 50) were perennial forbs, and 10% (5 of 50) were perennial grasses; there was also 1 native forb species of unidentifiable life-history.

**Table 4.7:** 2008 and 2009 absolute cover values (interannual subset); total of 12,600 point hits for each year

	2008 % absolute cover	2009 % absolute cover
Native species	4.3	5.2
Non-native species	77.9	79.8
Unidentifiable species	1.1	0.4
Non-plant material (litter, soil, rock, moss)	16.7	14.6
Purple needlegrass ( <i>Nassella pulchra</i> ) (most abundant <b>native</b> species)	1.3	0.9
Johnny jump-up ( <i>Viola pedunculata</i> ) (2nd most abundant <b>native</b> species)	0.4	0.6
Wild oats ( <i>Avena fatua</i> ) (most abundant species overall)	12.4	12.9
Broadleaf filaree ( <i>Erodium botrys</i> ) (2 <sup>nd</sup> most abundant species in 2009, 3 <sup>rd</sup> in 2008)	11.7	10.9
Annual ryegrass ( <i>Lolium multiflorum</i> ) (3 <sup>rd</sup> most abundant species in 2009, 2 <sup>nd</sup> in 2008)	12.1	9.3

FINAL DRAFT REPORT

**Table 4.8:** Rank for all species, plus litter and soil, with  $\geq 1\%$  absolute cover (all plots)

Rank	2008			2009		
	Species	Origin	% absolute cover	Species	Origin	% absolute cover
1	<i>Avena fatua</i>	exotic	12.4	<i>Avena fatua</i>	exotic	12.9
2	<i>Lolium multiflorum</i>	exotic	12.1	<i>Erodium botrys</i>	exotic	10.9
3	<i>Erodium botrys</i>	exotic	11.7	<i>Lolium multiflorum</i>	exotic	9.3
4	litter		10.5	litter		8.6
5	<i>Bromus diandrus</i>	exotic	8.8	<i>Bromus madritensis</i> ssp. <i>madritensis</i>	exotic	7.5
6	<i>Bromus hordeaceus</i>	exotic	7.2	<i>Bromus hordeaceus</i>	exotic	7.1
7	soil		6.0	<i>Bromus diandrus</i>	exotic	6.8
8	<i>Bromus madritensis</i> ssp. <i>madritensis</i>	exotic	4.8	<i>Trifolium hirtum</i>	exotic	6.0
9	<i>Avena</i> sp.	exotic	3.9	soil		5.9
10	<i>Brachypodium distachyon</i>	exotic	3.2	<i>Avena</i> sp.	exotic	4.1
11	<i>Avena barbata</i>	exotic	3.2	<i>Brachypodium distachyon</i>	exotic	3.0
12	<i>Erodium cicutarium</i>	exotic	1.4	<i>Avena barbata</i>	exotic	2.8
13	<i>Nassella pulchra</i>	<b>native</b>	1.3	<i>Erodium cicutarium</i>	exotic	1.7
14	<i>Vulpia bromoides</i>	exotic	1.3	<i>Hordeum marinum</i> ssp. <i>gussoneanum</i>	exotic	1.2
15	<i>Hordeum marinum</i> ssp. <i>gussoneanum</i>	exotic	1.1	<i>Vulpia bromoides</i>	exotic	1.0
16	unknown grass	unk.	1.0			
<b>Total % cover:</b>			90.0	<b>Total % cover:</b>		88.9



**5.0 Purple needlegrass dynamics**

The bunchgrass Purple needlegrass (*Nassella pulchra*) is the most abundant native species in our study plots. Over the course of the Project, Purple needlegrass has been found on transects in 5 out of the 7 Valley grassland parks (Table 5.1). Purple needlegrass's main presence is at Chabot Ridge and Vasco Caves, parks which had grazed and ungrazed comparison plots. Unfortunately, in both locations, circumstances have made evaluating differences between grazed and ungrazed plots difficult. In 2007, ungrazed plots at Chabot Ridge started being grazed, and they have been subject to mowing and nearby oak planting for several years. Chabot Ridge was not sampled in 2008 or 2009. At Vasco Caves, there was only one ungrazed Purple needlegrass plot, and the grazed plot with the highest Purple needlegrass cover burnt in the June 2006 wildfire, likely reducing cover, at least in the first year after the fire. These confounding factors make it difficult to draw strong conclusions about the effect of grazing on Purple needlegrass.

To address the lack of paired grazed/ungrazed plots in areas of high Purple needlegrass cover, we added three new plots to Vasco Caves in 2008. Plots were randomly located in areas with high Purple needlegrass cover. Two of the plots are not grazed, the other is grazed.

As noted in previous reports, Purple needlegrass has exhibited a steady decline over the course of the project (Table 5.1). The decline occurred in all parks and on grazed and ungrazed plots leading us to surmise that the decline was related to regional environmental factors rather than management activities. In 2008, this trend slowed somewhat, with plots maintaining cover levels similar to those of previous years, and even increasing, particularly at Vasco Caves plots. The increase occurred in multiple parks and on both grazed and ungrazed plots, lending credence to the hypothesis that the fluctuations in Purple needlegrass cover are driven by regional environmental phenomena, e.g., rainfall amount and pattern, rather than management activities.

However, in 2009, annual average cover of Purple needlegrass dropped once again. This decrease in Purple needlegrass cover occurred at all parks sampled in 2009 except for Pleasanton Ridge (Table 5.1). At Pleasanton Ridge, Purple needlegrass increased on 3 of the 4 Purple needlegrass plots, in contrast to the general decline on both grazed and ungrazed plots at Morgan Territory, Sunol, and Vasco Caves, and in contrast to the two previous years at Pleasanton Ridge in which Purple needlegrass was not hit in any plots. Interestingly, two of the Pleasanton Ridge plots were not grazed in 2009 for the first time since the beginning of this study; one of these plots displayed the park's largest increase in Purple needlegrass cover, while the other plot contained no Purple needlegrass for the third year in a row. The other two Pleasanton Ridge plots containing Purple needlegrass were sheep-grazed as normal. These disparate trends again suggest that grazing plays only a limited role in Purple needlegrass dynamics.

**5.1 Management implications**

Fluctuations in Purple needlegrass cover appear to be driven primarily by regional environmental factors with livestock grazing exerting little influence. The installation of additional grazed and ungrazed plots at Vasco Caves should help confirm or refute this hypothesis over the next few years.

**Table 5.1:** Purple needlegrass (*Nassella pulchra*) % absolute cover and grazing status, 2003-2009; VC10 sheep-grazed 2003-2004, ungrazed 2005-2009; PR4-6 not grazed in 2009

Plot ID	percent absolute cover							grazing status
	2003	2004	2005	2006	2007	2008	2009	
MT6	0.7	0.4	3.6	0.4	0.4	0	0.4	cattle
MT7			0.7	0	0	0	0.0	cattle
MT8			1.1	0	0	0.4	0.0	cattle
MT10			0	0	0	0.4	0.0	ungrazed
MT11				1.8	0.4	1.8	0.4	ungrazed
MT14				0	0	0.4	0.0	cattle
PR5	9.3*	8.2*	9.3*	1.1*	0*	0*	4.3*	cattle* / ungrazed <sup>+</sup>
PR6	1.1*	0*	0.4*	0*	0*	0*	0 <sup>+</sup>	cattle* / ungrazed <sup>+</sup>
PR7	0	0	0	0.7	0	0	0.4	sheep
PR8	2.9	1.8	1.4	0.4	0	0	1.4	sheep
SU2			0.4	0.4	0	0	0	cattle
SU3			0	0	0	0.4	0	cattle
SU6			7.1	3.6	4.3	4.6	3.9	cattle
SU9			0.7	0	0	0	0	ungrazed
SU10							0.7	ungrazed
VC2	21.8	18.9	15	11.1	5	22.1	8.2	sheep (6/2006 fire)
VC3	2.5	3.6	1.4	2.1	1.8	6.1	2.9	sheep
VC8	3.2	6.8	2.9	0.7	1.8	2.9	2.1	sheep (6/2006 fire)
VC9	0	0.7	0	0.4	0.7	0.4	0.4	sheep (6/2006 fire)
VC10	11.4*	6.8*	12.1 <sup>+</sup>	10.4 <sup>+</sup>	18.9 <sup>+</sup>	20.7 <sup>+</sup>	18.2 <sup>+</sup>	sheep* / ungrazed <sup>+</sup>
VC15						17.9	4.3	ungrazed
VC16						12.5	8.2	ungrazed
VC17						9.3	7.9	sheep
<b>Annual average cover on NAPU plots</b>	<b>7.7</b>	<b>6.5</b>	<b>4.2</b>	<b>3.3</b>	<b>2.5</b>	<b>4.5</b>	<b>2.8</b>	

**6.0 Native annual and perennial forbs and grazing status (all plots)**

In their large-scale study of California's coastal prairie grassland type, Hayes and Holl (2003) found higher native annual forb species richness and cover on cattle-grazed sites than they found on ungrazed sites. They hypothesized that reduced litter depth and increased bare soil on grazed sites favored the growth and germination of annual forbs. Hayes and Holl's findings were supported by EBRPD's Valley Grassland data from 2006: native annual forb cover and richness on cattle-grazed plots were significantly greater than on ungrazed plots. In the drought years of 2007 and 2008, native annual forb cover and richness on cattle-grazed plots continued to be significantly greater than on ungrazed plots, although the differences between grazed and ungrazed plots tended to be smaller. A third consecutive year of drought occurred in 2009.

FINAL DRAFT REPORT

We analyzed both native annual and native perennial forb species richness and cover for the 2009 season. Please note that although the cattle-grazed plots at Pleasanton Ridge were not grazed during the 2009 season, we chose to analyze these plots as cattle-grazed because their vegetation composition was more characteristic of grazed than ungrazed grassland.

In 2009, 51% (26 of 51) of the plots had native annual forbs present, slightly less than in 2008. Of these 26 plots, 46% were cattle-grazed, 31% ungrazed, and 23% sheep-grazed. Native perennial forbs were found on 49% (25 of 51) of the plots in 2009. Cattle-grazed and ungrazed plots both accounted for 44% of these 25 plots, and sheep grazed plots accounted for 12% of the plots with native perennial forbs present.

In 2009, average relative cover of both native annual and perennial forbs continued to be greater on cattle-grazed plots than on ungrazed plots (Table 6.0). Cattle-grazed plots had an average relative cover of native annual forbs of 6.05% and ungrazed plots 1.24%; this difference was statistically significant (p-value=0.02; 2-tailed t-tests with unequal variance). Relative to 2008, annual forb cover rose on both cattle-grazed plots (2008: 2.48%) and ungrazed plots (2008: 0.79%). Average relative cover of native perennial forbs was 4.21% on cattle-grazed plots and 0.92% on ungrazed plots; this difference was just short of being statistically significant (p-value=0.11). Compared to 2008, perennial forb cover also rose on both cattle-grazed plots (2008: 3.0%) and ungrazed plots (2008: 0.80%).

Average species richness of both native annual and perennial forbs was greater on cattle-grazed than ungrazed plots in 2009 (Table 6.0). Native annual forbs had an average species richness of 3.88 on cattle-grazed plots and 0.85 on ungrazed plots, a highly statistically significant difference (p-value= 0.005; 2-tailed t-test with unequal variance). Native perennial forbs had an average species richness of 1.53 on cattle-grazed plots and 0.70 on ungrazed plots, a statistically significant difference (p-value= 0.05; 2-tailed t-test with unequal variance). Compared to native species richness in 2008, cattle-grazed and ungrazed annual forbs (2008: 1.9 and 0.5 respectively) and cattle-grazed perennial forbs (2008: 1.3) increased while ungrazed perennial forbs fell slightly (2008: 0.8).

**Table 6.0:** 2009 cover and species richness for native forbs

	% average relative cover		Average species richness	
	annuals	perennials	annuals	perennials
Cattle-grazed	6.05	4.21	3.88	1.53
Ungrazed	1.24	0.92	0.85	0.70

Average percent relative cover of native annual forbs increased on all cattle-grazed plots from 2008 to 2009, but there was no clear trend observed on ungrazed or sheep-grazed plots (Table 6.1). At Morgan Territory, relative cover of native annual forbs on cattle-grazed plots (1.98%) was, once again, greater than on ungrazed plots (0.22%), though this was not quite a statistically significant difference (p-value=0.15); native annual forb cover on ungrazed plots had overtaken cover on grazed plots between 2007 and 2008 at this park. Cattle-grazed plots at Sunol-Ohlone continued to have a much higher relative cover of native annual forbs than ungrazed plots, this difference being statistically significant (p-value=0.03). Cattle-grazed plots had a higher relative cover of annual forbs than sheep-grazed plots at Pleasanton Ridge, though this difference was not statistically significant (p-value=0.41). Sheep-grazed plots at Vasco

FINAL DRAFT REPORT

Caves continued to have a greater relative cover of native annual forbs than ungrazed plots, though the difference between the management types decreased from 2008 to 2009, losing statistical significance.

**Table 6.1:** 2008 and 2009 average native annual forb percent relative cover by management type within park (all plots; plots in same color are paired plots within the same park) and 2009 p-values from 2-tailed t-tests with unequal variances comparing native cover

Park	Grazing status	Average % relative cover, 2008	Average % relative cover, 2009	p-values from t-tests for 2009
Morgan Territory	ungrazed	0.94	0.22	0.15
Morgan Territory	cattle	0.65	1.98	
Pleasanton Ridge	cattle*	3.27	4.44	0.41
Pleasanton Ridge	sheep	0.00	0.00	
Sunol-Ohlone	ungrazed	1.28	3.23	0.03
Sunol-Ohlone	cattle	4.46	12.48	
Vasco Caves	ungrazed	0.25	0.42	0.41
Vasco Caves	sheep	1.21	1.03	

\*Pleasanton Ridge cattle grazed plots were not grazed in 2009

As occurred with average percent relative cover of native annual forbs, average relative cover of native perennial forbs increased on all cattle-grazed plot between 2008 and 2009, while sheep-grazed and ungrazed plots displayed no clear trend across parks (Table 6.2). However, in contrast to the cover results for native annual forbs, native perennial forb cover remained greater on ungrazed plots than cattle-grazed plots at Morgan Territory in 2009, though both management types had low percent covers and the difference was not statistically significant. Cattle-grazed plots at Sunol-Ohlone had a much greater relative cover of native perennial forbs than ungrazed plots, this difference being statistically significant (p-value=0.09). Cover of native perennial forbs on cattle-grazed plots at Pleasanton Ridge was greater than cover on sheep-grazed plots but was not statistically significant (p-value=0.23). At Vasco Caves, average native perennial forb cover decreased on both ungrazed and sheep-grazed plots, ungrazed plot cover of native perennial forbs overtaking cover on sheep-grazed plots; however the difference was not statistically significant (p-value=0.48).

Average species richness of native annual forbs also increased on all cattle-grazed plots between 2008 and 2009, but sheep-grazed and ungrazed plots showed no obvious trend (Table 6.3). Average native annual forb richness on the grazed plots at Morgan Territory (cattle) and Vasco Caves (sheep) were just short of being statistically significantly greater than their ungrazed counterparts (p-values=0.14 and 0.17, respectively). At Sunol-Ohlone, there was a highly statistically significant difference between native annual forb species richness on cattle-grazed plots (7.50) and ungrazed plots (2.00), with a p-value of 0.004. There was a three-fold increase in average species richness of native annual forbs on cattle-grazed plots at Pleasanton Ridge from 2008 (1.00) to 2009 (3.00); sheep-grazed plot native annual forb species richness remained at 0, but the difference between cattle-grazed and sheep-grazed plots was still not statistically significant (p-value=0.36).

**Table 6.2:** 2008 and 2009 average native perennial forb percent relative cover by management type within park (all plots; plots in same color are paired plots within the same park) and 2009 p-values from 2-tailed t-tests with unequal variances comparing native cover

Park	Grazing status	Average % relative cover, 2008	Average % relative cover, 2009	p-values from t-tests for 2009
Morgan Territory	ungrazed	0.44	0.56	0.56
Morgan Territory	cattle	0.24	0.32	
Pleasanton Ridge	*cattle	0.57	1.11	0.23
Pleasanton Ridge	sheep	0.00	0.00	
Sunol-Ohlone	ungrazed	0.26	1.71	<b>0.09</b>
Sunol-Ohlone	cattle	8.04	10.81	
Vasco Caves	ungrazed	0.83	0.49	0.48
Vasco Caves	sheep	1.58	0.26	

\*Pleasanton Ridge cattle grazed plots were not grazed in 2009

**Table 6.3:** 2008 and 2009 average native annual forb percent species richness by management type within park (all plots; plots in same color are paired plots within the same park) and 2009 p-values from 2-tailed t-tests with unequal variances comparing native species richness

Park	Grazing status	Average species richness, 2008	Average species richness, 2009	p-values from t-tests for 2009
Morgan Territory	ungrazed	0.38	0.38	0.14
Morgan Territory	cattle	0.88	1.50	
Pleasanton Ridge	cattle*	1.00	3.00	0.36
Pleasanton Ridge	sheep	0.00	0.00	
Sunol-Ohlone	ungrazed	0.67	2.00	<b>0.004</b>
Sunol-Ohlone	cattle	3.83	7.50	
Vasco Caves	ungrazed	0.50	0.33	0.17
Vasco Caves	sheep	1.36	1.27	

\*Pleasanton Ridge cattle grazed plots were not grazed in 2009

Generally, average species richness was low for native perennial forbs. Average native perennial forb richness displayed a statistically significant difference between paired management types only at Sunol-Ohlone (p-value=0.001), cattle-grazed plots (3.17) having a greater average richness than ungrazed plots (0.83) (Table 6.4). Both grazed and ungrazed plots at Sunol-Ohlone showed an increase in average perennial forb richness between 2008 and 2009. Native perennial species richness on ungrazed plots at Morgan Territory remained slightly greater than that on cattle-grazed plots. Likewise, perennial species richness continued to be a little greater on ungrazed plots than sheep-grazed plots at Vasco Caves. Cattle-grazed plots at Pleasanton Ridge increased slightly in perennial forb species richness in 2009 while perennial forbs continued to be absent from sheep-grazed plots, but this difference was not statistically significant (p-value=0.23).

**Table 6.4:** 2008 and 2009 average native perennial forb percent species richness by management type within park (all plots; plots in same color are paired plots within the same park) and 2009 p-values from 2-tailed t-tests with unequal variances comparing native species richness

Park	Grazing status	Average species richness, 2008	Average species richness, 2009	p-values from t-tests for 2009
Morgan Territory	ungrazed	0.75	0.63	0.74
Morgan Territory	cattle	0.50	0.50	
Pleasanton Ridge	cattle*	0.67	1.00	0.23
Pleasanton Ridge	sheep	0.00	0.00	
Sunol-Ohlone	ungrazed	0.33	0.83	<b>0.001</b>
Sunol-Ohlone	cattle	2.67	3.17	
Vasco Caves	ungrazed	1.33	0.67	0.62
Vasco Caves	sheep	0.73	0.45	

\*Pleasanton Ridge cattle grazed plots were not grazed in 2009

#### 6.1 Management Implications

In spite of 2009 being the third consecutive drought year for California, cattle grazing consistently favored native annual forbs. Compared to 2008, annual forbs on cattle-grazed plots displayed an increase in both average species richness and cover in 2009. The benefits of cattle grazing versus no grazing seem to be less significant for perennial forbs, but cattle grazing sustains a greater cover and richness of both native annual and perennial forbs at the landscape level. This is noteworthy because forbs constitute the majority of the native species richness found on Park District grasslands.

The effect of sheep grazing on native forb abundance is less clear. Sheep-grazed plots at Vasco Caves had no native forbs from 2006 to 2009; however, there are no ungrazed control plots with which to compare these results. At Vasco Caves, sheep-grazed plots had more annual but fewer perennial forbs than ungrazed plots. Interestingly, in contrast to most of the other sites, forb richness and cover at Vasco Caves decreased between 2008 and 2009 on both sheep-grazed and ungrazed plots, suggesting a site rather than a management cause.

#### 7.0 Purple false-brome watch (all plots)

Purple false-brome (*Brachypodium distachyon*), a non-native grass, may be spreading on EBRPD properties. Since 2003, it has been observed on over 50% of the study plots; of the four parks sampled in 2009, only at Vasco Caves were there no purple false-brome observations. Although purple false-brome cover has not shown significant increases over the past three drought years and has decreased slightly on some plots, the species does appear to be spreading each year (Table 7.1). It was hit on two further Morgan Territory plots in 2009 and was hit or observed in two of the three newly established Sunol/Ohlone plots.

The ecological impacts of purple false-brome are unknown, although the California Invasive Plant Council's (Cal-IPC) Plant Assessment Form for this species notes that purple

FINAL DRAFT REPORT

false-brome can “form dense stands in some locations, particularly in oak woodlands” which could “reduce diversity and prevent native species from establishing” (<http://portal.cal-ipc.org/files/PAFs/Brachypodium%20distachyon.pdf>, accessed June 2007). Cal-IPC’s Invasive Plant Inventory (Cal-IPC 2006) assigns purple false-brome an invasive plant score of “moderate,” that is: a species that has “substantial and apparent—but generally not severe—ecological impacts.” In addition, DiTomaso and Healy (2007) note that purple false-brome makes poor forage because of its fibrous stems, sparse foliage, and long awns, which can also injure animals. Unfortunately, no information about control of this grass was found.

**Table 7.1:** Purple false-brome hits, 2003-2009; ND=no detections; OBS=observed on plot but not hit

Plot	2003 hits	Plot	2004 hits	Plot	2005 hits	Plot	2006 hits	Plot	2007 hits	Plot	2008 hits	Plot	2009 hits
						MT1	5	MT1	1	MT1	4	MT1	5
								MT2	2	MT2	2		ND
										MT3	5	MT3	1
								MT4	1		ND		ND
								MT6	OBS	MT6	OBS	MT6	OBS
										MT7	OBS	MT7	OBS
Plots not in project						MT8	1	MT8	8	MT8	3	MT8	4
Plots not in project				MT9	5	MT9	14	MT9	14	MT9	25	MT9	37
Plots not in project						MT10		MT10	2	MT10	OBS	MT10	OBS
Plots not in project						MT11	62	MT11	38	MT11	38	MT11	14
Plots not in project												MT12	1
Plots not in project						MT13	62	MT13	57	MT13	52	MT13	79
Plots not in project						MT14	56	MT14	46	MT14	43	MT14	26
Plots not in project						MT15	OBS	MT15	1	MT15	2	MT15	2
Plots not in project						MT16		MT16	OBS		ND	MT16	1
PR6	1		ND		ND		ND		ND		ND		ND
PR7	91	PR7	34	PR7	35	PR7	76	PR7	46	PR7	45	PR7	48
PR9	23	PR9	72	PR9	55	PR9	62	PR9	57	PR9	35	PR9	34
						VC5	OBS		ND		ND		ND
Plots not in project				SU1	7	SU1	9	SU1	11	SU1	2	SU1	2
Plots not in project				SU2	1	SU2	4	SU2	3	SU2	4	SU2	6
Plots not in project				SU3	6		ND		ND		ND		ND
Plots not in project				SU4	44	SU4	63	SU4	67	SU4	63	SU4	51
Plots not in project				SU5	5		ND		ND	SU5	1		ND
Plots not in project				SU6	65	SU6	107	SU6	75	SU6	78	SU6	69
Plots not in project										SU8	OBS		ND
Plots not in project				SU9	2	SU9	5	SU9	OBS	SU9	2	SU9	OBS
Plots not in project												SU10	97
Plots not in project												SU11	OBS

FINAL DRAFT REPORT

**8.0 Invasive species listed by the California Invasive Plant Council (all plots)**

In 2009, we found two species rated as “high” in the California Invasive Plant Council’s Invasive Plant Inventory (Cal-IPC 2006): Red brome (*Bromus madritensis* ssp. *rubens*) and Medusahead (*Taeniatherum caput-medusae*). Because we did not survey the invasive-species-rich Brushy Peak, Chabot Ridge, and Sycamore Valley in 2008 and 2009, the number of invasive species we observed in the last two years was lower than in earlier years of this study.

Cal-IPC describes species with an invasive plant score of “high” as follows: “These species have severe ecological impacts on ecosystems, plant and animal communities, and vegetational structure.

Their reproductive biology and other attributes are conducive to moderate to high rates of dispersal and establishment. These species are usually widely distributed ecologically, both among and within ecosystems” (Cal-IPC 2003a, p.4).

Table 8.1 lists the 2009 location and percent relative cover for Medusahead. The only site where Medusahead was hit on transect in 2009 was at Morgan Territory plot MT2, but relative cover on this plot was < 1%. Between 2007 and 2008, cover of the invasive annual grass Medusahead doubled at Sunol plot SU5 (2008: 5.5% relative cover) in High Valley though remaining at a fairly low level. However, Medusahead was not hit on transect at SU5 in the 2009 drought year, though it was present on plot. In addition, Medusahead was found on plot though not hit on transect at Pleasanton Ridge plots PR4 and PR5.

Implementing a control program may inhibit the spread of medusahead. Recent publications describing Medusahead control include Kyser et al. (2007) for herbicide, DiTomaso et al. (2007) for sheep-grazing, and Kyser et al. (2008) for prescribed burning.

Red brome is not listed because its high Cal-IPC rating is due to the species’ deleterious effects in the Mohave Desert; in the California annual grassland, Red brome is unlikely to have severe ecological impacts (Cal-IPC 2003b).

**Table 8.1:** Location and % relative cover for invasive species found in 2009 (all plots) rated as “high” in the California Invasive Plant Council’s Invasive Plant Inventory (Cal-IPC 2006)

Plot	Grazing status	Species	Scientific name	% relative cover
Morgan Territory plot MT2	ungrazed	Medusahead	<i>Taeniatherum caput-medusae</i>	0.9

**9.0 2008/2009 precipitation data from the Livermore weather station**

We present data from the Livermore NOAA weather station to show the general weather trend in the region for the rain years 2002/03 to 2008/09.

Rainfall during the initial years of the study was mostly close to average or above average with no bad drought years. 2006/07 finally provided a drought year, with much less rain and a different pattern of rainfall timing over the growing season; 2007/08 and 2008/09 were also drought years though less dry overall than the 2006/07.

In Livermore, total precipitation in the 2008/09 rain-year was 279 mm, 74% of the 30-year mean, about the same as the previous rain-year (Table 9.1).

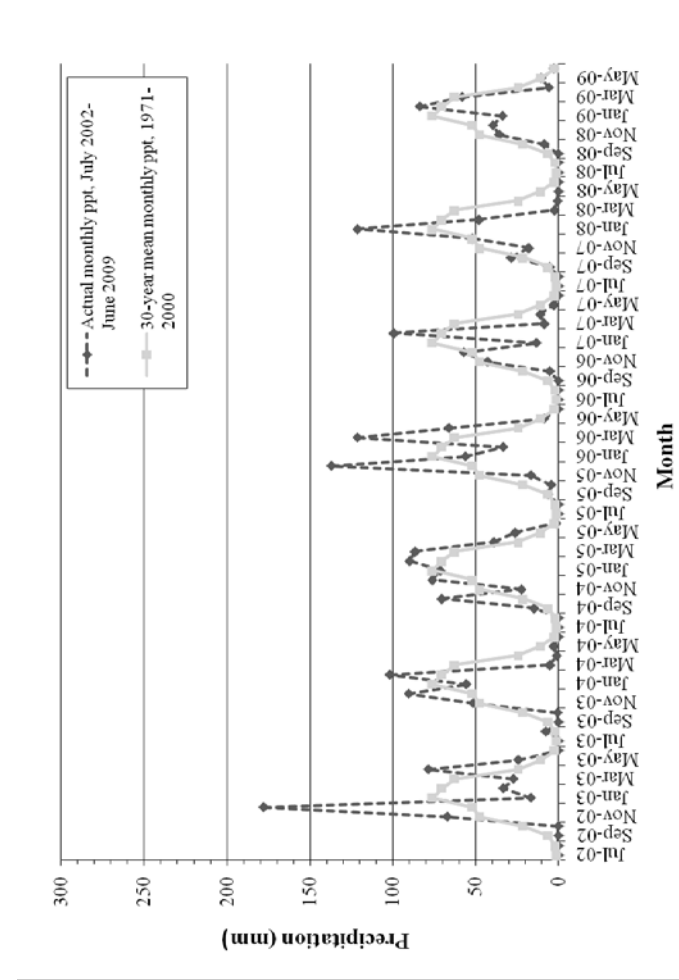
FINAL DRAFT REPORT

**Table 9.1:** 30-year mean annual rainfall and annual rainfall, 2002/03-2008/09, (in mm) for the Livermore NOAA weather station

	Annual rainfall (mm)	% of 30-year mean
30-year (1971 - 2000) mean	376	
<b>Rain year</b>		
July 2002 - June 2003	425	113 %
July 2003 - June 2004	316	84 %
July 2004 - June 2005	498	132 %
July 2005 - June 2006	450	120%
July 2006 - June 2007	240	64%
July 2007 - June 2008	276	73%
July 2008 - June 2009	279	74%

Rainfall timing has a strong effect on Valley grassland species composition. In 2008/09, fall and winter were consistently drier than average, with an especially droughty January. February delivered a modestly greater-than-average rainfall, followed by an average March, a dry April, and an average May and June (Figure 9.1). This drought pattern differed from the previous two drought years' patterns: while there were no winter months with large rainfall spikes, spring was closer to average rainfall than the very dry previous years.

FINAL DRAFT REPORT



**Figure 9.1:** Actual monthly precipitation (in mm), July 2004 - June 2009, and 30-year mean (1971-2000) monthly precipitation (in mm) for Livermore NOAA weather station

**10.0 Avian sampling 2009**

10.1 2009 Valley Grassland focus

Field work in 2009 followed the same plan and methodology as previous years, consisting of 42 Valley Grassland point count plots, 16 ungrazed and 32 grazed. Chabot Ridge and Brushy Peak are removed from the survey because of the lack of a grazed and ungrazed comparison at both parks as well as the consistent absence of grassland birds at Chabot-Fairmont Ridge (see 2007 report for a more detailed explanation). Bird surveys continue at Sycamore Valley due to the presence of grassland bird species and the grazed and ungrazed plot comparison within the park. As part of the targeted Purple Needlegrass (*Nassella pulchra*) grazing comparison plots, one ungrazed plot was added to the point count survey at Vasco Caves.

10.2 Avian data collection methods

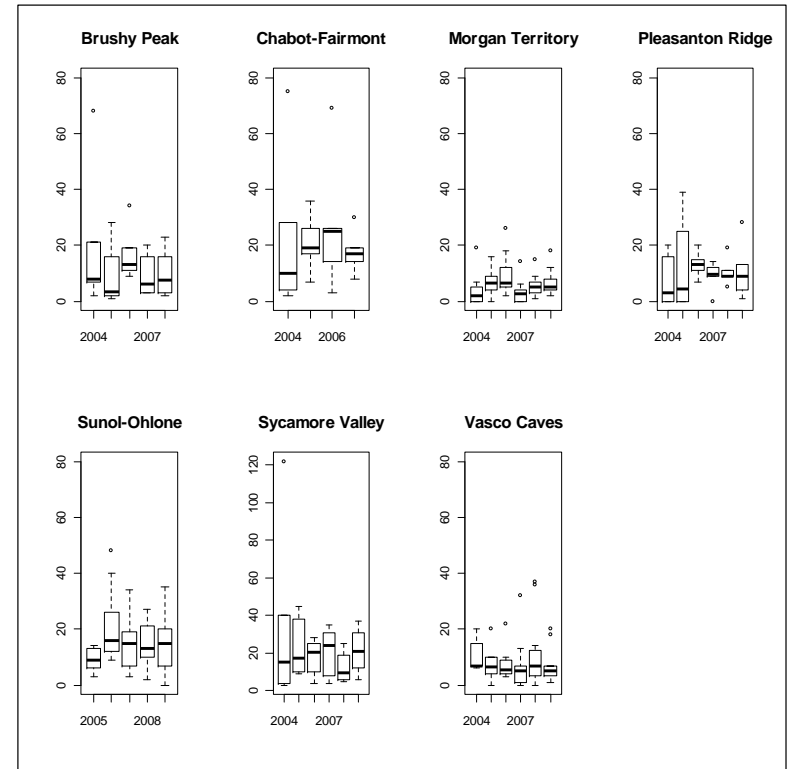
Avian data collection involves 10-minute, 100-meter variable circular plot point count surveys following USFWS protocol (Ralph et al. 1995). Between March 31 and June 15, three surveys were conducted in each park between 2004 and 2009. Three point count visits per plot in a breeding season are necessary to maximize the number of detections in what appears to be a low-density grassland bird community.

10.3 2004-2009 Avian dataset overview

Summaries within this report use a restricted avian dataset that only includes bird observations on plot within 100 meters of the plot center. The Breeding Bird Status table (Table 11.1, p. 33) is the only summary that uses the entire dataset of bird observations; incorporating all point count survey detections, including individuals detected outside of the timed count, as well as any observations of bird activity during other visits to the park.

On plot avian detection rates remain fairly constant and show no significant temporal trend over the years of the study, 2004-2009 (Figure 10.1). Plot detection rates are counted as the total number of individual birds on plot (within 100m of center) added cumulatively over three surveys per breeding season. Figure 10.1 uses Tukey boxplots to show by park the spread of annual plot detection numbers. These boxplots illustrate that median plot detection numbers stay more consistent at Morgan Territory and Vasco Caves. Outlier or extreme values of park plot detection rates are caused by sporadic occurrences of large flocks on plot (e.g. California Quail, American Pipits, Cedar Waxwings). In spite of the differences in climate, 2007-2009 had below average rainfall, there is no obvious trend showing climatic effects on median plot avian detection rates over all the parks and years.

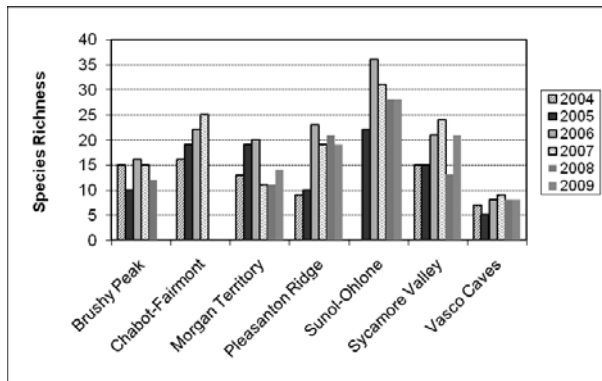
**Figure 10.1:** 2004-2009 annual park avian detection rates shown with a Tukey boxplot, dark lines are the median of summed plot detections per year per park, whiskers are the minimum and maximum plot values unless that value is 1.5 times the innerquartile range when it is represented with an outlier dot; Brushy Peak not surveyed 2009, Chabot-Fairmont Ridge not surveyed 2008-2009, Sunol-Ohlone not surveyed 2004; data restricted to detections of individuals on plot ( $\leq 100m$ ); note y-axis scale in Sycamore Valley different to accommodate outlier



Using the restricted dataset (detections  $\leq 100m$ ), Sunol-Ohlone continues to have the highest overall park avian species richness while Vasco Caves remains the lowest (Figure 10.2).

This trend is also reflected in the cumulative park avian species richness within the 2004-2009 Breeding Bird Status table (Table 11.1). This complete dataset of bird observations, using data as well as notes from all park visits, shows that species richness is highest for Sunol-Ohlone and lowest for Vasco Caves. Vasco Caves, in contrast, has the highest number of confirmed breeders. A species is considered a confirmed breeder when it has been observed in an activity that clearly represents reproductive activity (e.g. active nest or adult with juveniles).

**Figure 10.2:** 2004-2009 park avian species richness interannual comparison; data restricted to detections  $\leq 100\text{m}$



**11.0 Grassland bird focal species overview**

Focal grassland species of conservation and management concern, as determined by the California Partners in Flight Grassland Bird Conservation Plan (CPIF 2000), observed in the project study area are: Burrowing Owl (*Athene cucularia*), Ferruginous Hawk (*Buteo regalis*), Grasshopper Sparrow (*Ammodramus savannarum*), Northern Harrier (*Circus cyaneus*), Savannah Sparrow (*Passerculus sandwichensis*), Western Meadowlark (*Sturnella neglecta*), and White-tailed Kite (*Elanus leucurus*). The Mountain Plover (*Charadrius montanus*) is the only CPIF primary focal species not found on our plots from 2002-2009; although it is a wintering species much less likely to be encountered during our intensive breeding season point count survey.

Secondary species, defined by the CPIF as birds nesting and/or primarily foraging in grasslands, observed in areas covered by this project are: Blue Grosbeak (*Guiraca caerulea*), Horned Lark (*Eremophila alpestris*), Mallard (*Anas platyrhynchos*), Prairie Falcon (*Falco mexicanus*), Ring-necked Pheasant (*Phasianus colchicus*), Song Sparrow (*Melospiza melodia*), Swainson’s Hawk (*Buteo swainsoni*), and Tricolored Blackbird (*Agelaius tricolor*).

**11.1 Grassland bird guild overview**

Bird species with direct associations to a particular vegetation or habitat type are good indicators of ecosystem health (Carignan and Villard 2002). We chose four of the focal CPIF species to represent our grassland bird guild for their association with and dependence on grassland habitat within our sites: Grasshopper Sparrow, Horned Lark, Savannah Sparrow, and Western Meadowlark.

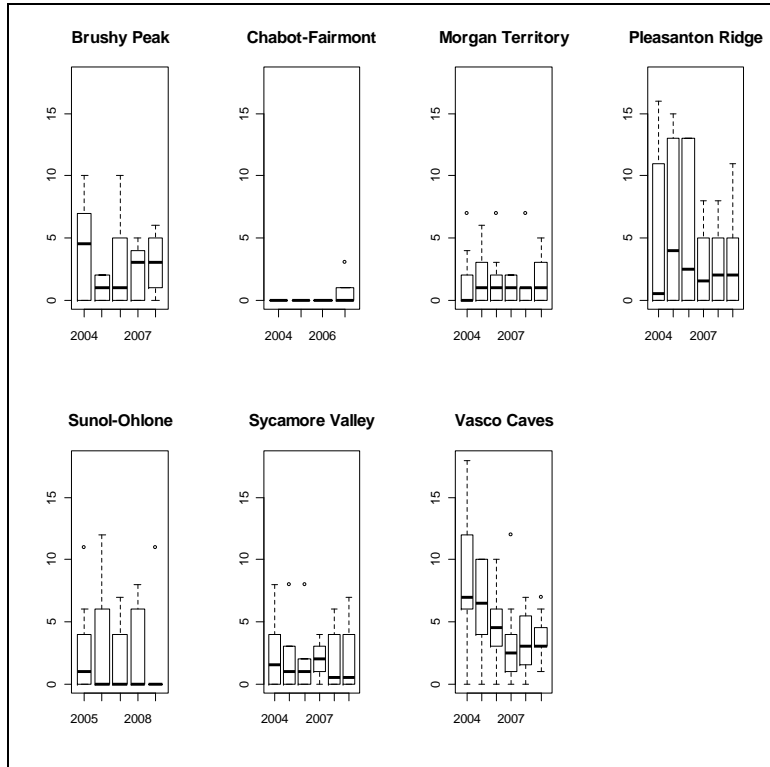
Comparing all the parks over 2004-2009, the grassland bird guild has a patchy distribution with low numbers of detection (Figures 11.1 and 11.2). None of the parks has a consistent yearly presence of all four of the guild species. For the guild, median plot detection rates (black lines within the boxplots) are heavily weighted by the number of zeros. In other words, across all of the parks the majority of plots have no guild species detected on plot. Guild plot detection rates are counted as the total number of guild species individuals on plot (within 100m of center) added cumulatively over three surveys per breeding season. Figure 11.1 uses Tukey boxplots to show by park the spread of annual guild plot detection numbers. The boxplots illustrate the close to zero grassland bird detection rate for Chabot-Fairmont Ridge. Vasco Caves is the only park where individuals from the guild are consistently found on a majority of the plots. Figure 11.1 shows that Vasco Caves had detections of at least one guild species on every plot in 2009.

Savannah Sparrows reappeared on plot in three parks (4 total detections) in 2009 after dropping to zero detections in 2008 (Figure 11.2). Some variability in species detection can be attributed to observer bias but in this case the observers remained the same over 2008-2009. Our most ubiquitous grassland species, the Western Meadowlark, has a downward trend throughout the study with the 2nd lowest number of observations in 2009 (38 total detections). Horned Larks, our second most abundant guild species, are remaining more or less consistent in their number of total detections per year. Grasshopper Sparrows are also remaining consistent with their total detection rates per year.

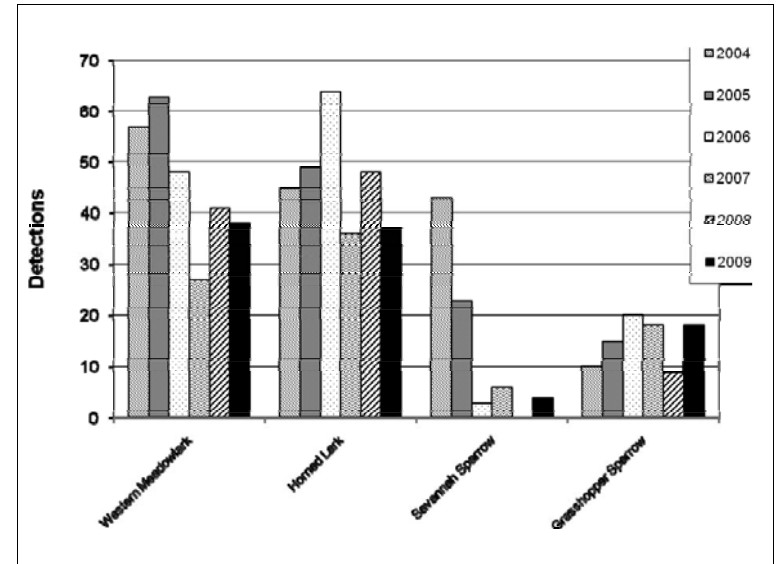
In 2009, grassland bird detections remain consistently low over all the parks. There is a possible effect of the drought years in the total detection numbers of Horned Larks and Grasshopper Sparrows. Detection numbers appear to drop for these two species in 2007-2008 from a peak in 2006 which may reflect the reproductive effect of lower precipitation in certain areas of the parks. Lower precipitation in these grasslands may have an effect on the amount of vegetation produced which may also influence the abundance of insects, the principle food source for these birds during the breeding season.

Overall the grassland bird guild remains a low density community, present in some areas and consistently absent from other locations within these parks. Future analyses looking at land-use history, current management, native species abundance or other abiotic factors may help to answer some of the reasons behind this patchy grassland bird distribution.

**Figure 11.1:** 2004-2009 annual park grassland bird guild detection rates shown with a Tukey boxplot, dark lines are the median of summed plot detections of the grassland guild species per year per park, whiskers are the minimum and maximum plot values unless that value is 1.5 times the innerquartile range when it is represented with an outlier dot; Brushy Peak not surveyed 2008-2009, Chabot-Fairmont Ridge not surveyed 2008-2009, Sunol-Ohlone not surveyed 2004; data restricted to detections of individuals on plot ( $\leq 100m$ )



**Figure 11.2:** 2004-2009 total detections of grassland bird guild species, species are ranked by total detections over all parks; only includes parks that are currently being surveyed; data restricted to detections  $\leq 100m$





FINAL DRAFT REPORT

**Table 11.1:** Valley grassland Breeding Bird Status 2004-2009

*Breeding bird status:*

- ) no evidence of breeding: bird encountered but no territorial or breeding behavior noted.
- 1) possible breeder: bird encountered singing or acting territorial only once during the breeding season (in suitable habitat).
- 2) Probable breeder: singing individual encountered on two or more days of point count surveys (within a season, at least one week apart); territorial behavior noted more than once at the same location; pair observed in courtship behavior.
- 3) Confirmed breeder: nest building observed; nesting material or fecal sac being carried by adult; active nest observed; dependent juveniles with adults.

Table includes both avian point counts and vegetation surveys, using all data; an asterisk (\*) indicates CPIF grassland focal species (Mountain Plover not detected) and any secondary species encountered (for more information on CPIF see Section 11.4). Note again that this table reflects observations made on grassland point counts and vegetation surveys. It does not cover other habitat types within district parkland.

Species	Brushy Peak	Chabot Ridge	Morgan Territory	Pleasanton Ridge	Sunol-Ohlone	Sycamore Valley	Vasco Caves	Number of parks in which species was observed, 2004-2009
Acorn Woodpecker	*		*	*	*	2		5
Allen's Hummingbird	*							1
American Coot				*				1
American Crow	*		2	1	*	2	*	6
American Goldfinch		*	1					2
American Kestrel	3	3	*	*	*	1	*	7
American Pipit	*		*	*	*			3
American Robin		1	2	2	1	*	1	6
Anna's Hummingbird	*	2	1	*	2	3		6
Ash-throated Flycatcher	1		1	1	1	2		5
Band-tailed Pigeon		*	*	*	*			4
Barn Swallow	*	*	*	*	*	*	1	7
Bewick's Wren	1	2	2	2	2			5
Black Phoebe	*	1	*	2	1	1		6
Black-crowned Night-Heron		3						1
Black-headed Grosbeak		1	2	2	2	1		5
Black-necked Stilt	*							1
Blue-gray Gnatcatcher				*				1
Blue Grosbeak*						*		1
Brewer's Blackbird	*	*	*	*	*	*	*	6
Brown-headed Cowbird	*	*	*		*	*		5
Bufflehead					*			1
Bullock's Oriole	1	2	1	*	2	2	2	7
Burrowing Owl							3	1
Bush-tit		1	1	*				3
California Quail	*	*	2	1	1	2		6
California Towhee	1	1	2	2	2	2		6
Canada Goose	*					*		2

FINAL DRAFT REPORT

Species	Brushy Peak	Chabot Ridge	Morgan Territory	Pleasanton Ridge	Sunol-Ohlone	Sycamore Valley	Vasco Caves	Number of parks in which species was observed, 2004-2009
Cassin's Vireo			1		2			2
Cedar Waxwing		1	*					2
Chestnut-backed Chickadee		2	*	2	2	1		5
Cliff Swallow	*	3	*	*	*	*	1	7
Common Raven	1	*	*	*	*		3	6
Cooper's Hawk			*		*	*		3
Dark-eyed Junco		2	2	2	2	1	2	6
Double-crested Cormorant							*	1
European Starling	3	3		*	2	*	*	6
Golden Eagle	*		*	*	*		*	5
Golden-crowned Sparrow	1	1		*	1	1		5
Grasshopper Sparrow*	2		2	3	2	2	2	6
Great Blue Heron				*				1
Great Egret				*				1
Great-horned Owl			2	1			3	2
Greater Yellowlegs				*				1
Hairy Woodpecker		*			*			2
Horned Lark*	2		3	3	2	1	3	6
House Finch	2	2	*	2	2	2	1	7
House Wren			2		1	1		3
Hutton's Vireo			2	*	2	1		4
Killdeer	2	*		1	*	*	*	6
Lark Sparrow			2	2	2			3
Lazuli Bunting		2	2	1	2	2		5
Lesser Goldfinch	*	*	2	2	2	2	1	7
Loggerhead Shrike	*					*	1	3
Long-billed Curlew		*					*	2
MacGillivray's Warbler				1	1			2
Mallard*	*	*	*	3	*	*	*	6
Mourning Dove	3	2	3	2	2	2	2	7
Northern Flicker		*	1	*	*		*	5
Northern Harrier*	*				*		*	3
Northern Mockingbird	1	2		2	1	2	1	6
Northern Rough-winged Swallow			*		*			2
Nuttall's Woodpecker		1	1	2	*	2	1	6
Oak Titmouse		1	2	2	3	2	*	6
Orange-crowned Warbler		1	2	2	2	1		5
Pacific-slope Flycatcher		1	*					2
Prairie Falcon	*						3	2
Purple Finch		1	1	2				3
Red-shouldered Hawk			2	*	*			3
Red-tailed Hawk	1	*	1	2	*	1	*	7
Red-winged Blackbird	2		2	2	1	3	3	6
Ring-necked Pheasant*						2		1

FINAL DRAFT REPORT

Species	Brushy Peak	Chabot Ridge	Morgan Territory	Pleasanton Ridge	Sunol-Ohlone	Sycamore Valley	Vasco Caves	Number of parks in which species was observed, 2004-2009
Rock Dove	*	*		*		*	3	5
Rock Wren					2		2	2
Rufous-crowned Sparrow		2			*	*		3
Ruby-crowned Kinglet	1			*				2
Savannah Sparrow*	*	1	1	1		2	2	6
Song Sparrow*			1	*		2		3
Spotted Towhee		2	2	1	2	1		5
Steller's Jay	*	*	2	2	*	*		6
Swainson's Hawk*							*	1
Tree Swallow	*	*				*		3
Tricolored Blackbird*	*					*	*	3
Turkey Vulture	*	*	*	*	*	*	*	7
Vaux's Swift			*					1
Violet-green Swallow			*		3	*	*	4
Warbling Vireo	*		2	1	2			4
Western Bluebird	3	1	*	1	1	1	*	7
Western Kingbird	2	1	*	*	1	2	2	7
Western Meadowlark*	2	1	2	2	2	2	3	7
Western Scrub Jay		2	2	2	1	2	*	6
Western Tanager	*	*	1		1		*	5
Western Wood-Peevee			1		1			2
White-breasted Nuthatch						2		1
White-crowned Sparrow	*	*		1		1	1	5
White-tailed Kite*	*		*		2	*	*	5
White-throated Swift	*	*	*	*	*	*		6
Wild Turkey		*	1	2	3	3		5
Willet	*							1
Wilson's Warbler	1		1					2
Wrenit	*	2	1	2	2			5
Yellow billed Magpie					*			1
Yellow-rumped Warbler	1	*		*				3
<b>Total confirmed breeders</b>	<b>4</b>	<b>2</b>	<b>2</b>	<b>3</b>	<b>3</b>	<b>3</b>	<b>8</b>	
<b>2004-2009 Cumulative Species Richness</b>	<b>53</b>	<b>60</b>	<b>69</b>	<b>70</b>	<b>71</b>	<b>62</b>	<b>45</b>	

FINAL DRAFT REPORT

12.0 References

- Bartolome, J.W., W.J. Barry, T. Griggs, and P. Hopkinson. 2007. Valley grassland. Chapter 14 in Barbour, M., T. Keeler-Wolf, and A.A. Schoenherr, eds. / **Terrestrial vegetation of California**. 3<sup>rd</sup> edition. Berkeley, CA: University of California Press.
- Bonham, C.D. 1989. **Measurements for terrestrial vegetation**. New York: Wiley. 338p.
- Cal-IPC (California Invasive Plant Council). 2003a. **Criteria for categorizing invasive non-native plants that threaten wildlands**. [http://www.cal-ipc.org/file\\_library/15666.pdf](http://www.cal-ipc.org/file_library/15666.pdf), accessed October 2005.
- Cal-IPC (California Invasive Plant Council). 2003b. **Plant assessment form [for *Bromus madritensis* ssp. *rubens*]**. [http://www.cal-ipc.org/file\\_library/11726.pdf](http://www.cal-ipc.org/file_library/11726.pdf), accessed January 2006.
- Cal-IPC (California Invasive Plant Council). 2006. **California invasive plant inventory**. Cal-IPC Publication 2006-02. Berkeley, CA: California Invasive Plant Council. Available at: <http://www.cal-ipc.org>.
- Carignan, V. and M. Villard. 2002. Selecting indicator species to monitor ecological integrity: a review. *Environmental monitoring and assessment* 78: 45–61.
- CPIF (California Partners in Flight). 2000. Version 1.0. *The draft grassland bird conservation plan: a strategy for protecting and managing grassland habitats and associated birds in California* (B. Allen, lead author). Stinson Beach, CA: Point Reyes Bird Observatory.
- DiTomaso, J.M., S.F. Enloe, and M.J. Pitcairn. 2007. Exotic plant management in California annual grasslands. Pages 281-296 in: M.R. Stromberg, J.D. Corbin, and C.M. D'Antonio (eds.), **California grasslands: ecology and management**. Berkeley, CA: University of California Press.
- DiTomaso, J.M. and E.A. Healy. 2007. **Weeds of California and other western states**. Oakland, CA: University of California Division of Agriculture and Natural Resources.
- Gea-Izquierdo, G., A.S. Gennet, and J.W. Bartolome. 2007. Assessing plant-nutrient relationships in highly invaded Californian grasslands using non-normal probability distributions. **Applied vegetation science** 10: 343-350.
- Hayes, G.F. and K.D. Holl. 2003. Cattle grazing impacts on annual forbs and vegetation composition of mesic grasslands in California. **Conservation biology** 17: 1694-1702.
- Kyser, G.B., J.M. DiTomaso, M.P. Doran, S.B. Orloff, R.G. Wilson, D. Lancaster, D. Lile, and M. Porath. 2007. Control of medusahead (*Taeniatherum caput-medusae*) and other annual grasses with imazapic. **Weed technology** 21: 66–75.

FINAL DRAFT REPORT

- Kyser, G.B., M.P. Doran, N.K. McDougald, S.B. Orloff, R.N. Vargas, R.G. Wilson, and J.M. DiTomaso. 2008. Site characteristics determine the success of prescribed burning for Medusahead (*Taeniatherum caput-medusae*) control. **Invasive plant science and management** 1: 376-384.
- McCune, B. and J.B. Grace. 2002. **Analysis of ecological communities**. Gleneden Beach, OR: MjM Software Design.
- Ralph, C.J., S. Droege, and J.R. Sauer. 1995. Managing and monitoring birds using point counts: standards and applications. In Ralph, C.J., J.R. Sauer, and S. Droege, eds. / **Monitoring bird populations by point counts**. USDA Forest Service Publication, Gen. Tech. Rep. PSW-GTR-149, Albany, CA.

FINAL DRAFT REPORT

**Appendix A: Published and unpublished work from the East Bay Regional Park District Grassland Monitoring Project**

A.1 Published articles and theses based on EBRPD project

Hopkinson, P., M. Stevenson, M. Hammond, S. Gennet, D. Rao, and J.W. Bartolome. 2009. Annual rye-grass: a new central California dominant? **Grasslands** 19: 4-8.

Bartolome, J.W., R.D. Jackson, and B.H. Allen-Diaz. 2008. Developing data-driven descriptive models for Californian grasslands. Pages 124-135 in: Hobbs, R.J. and K. N. Suding (eds.) / **New models for ecosystem dynamics and restoration**. Island Press, Washington DC.

D. Rao, S. Gennet, M. Hammond, P. Hopkinson, and J. Bartolome. 2008. A landscape analysis of grassland birds in a Valley Grassland-oak woodland mosaic. Pages 385-397 in Merenlender, A, D McCreary, and KL Purcell, tech. eds. / **Proceedings of the sixth California oak symposium: today's challenges, tomorrow's opportunities**. General technical report PSW-GTR-217. Albany, CA: U.S.D.A. Forest Service, Pacific Southwest Research Station.

*Abstract.* While little research has been done on California grassland birds, their populations are thought to be declining due to habitat loss, fragmentation, and degradation. We investigated the association between California grassland birds and their landscape-scale habitat matrix. The habitat is a mosaic of valley grassland with blue oak and coast live oak woodlands. In this study, we used logistic regression to analyze presence of Grasshopper Sparrows (*Ammodramus savannarum*), Horned Larks (*Eremophila alpestris*), Western Meadowlarks (*Sturnella neglecta*), Savannah Sparrows (*Passerculus sandwichensis*), and the guild as a whole in response to patch size, cover-type richness, and proportion of high intensity development, low intensity development, deciduous forest, and evergreen forest in the landscape. These landscape variables were analyzed for the 2004 and 2005 breeding seasons at three spatial scales: 500 m, 1 km, and 2 km buffer zones from the point count center. We found that the grassland bird guild as a whole was positively associated with patch size, proportion of low intensity development, and proportion of evergreen forest and negatively associated with cover-type richness, proportion of high intensity development, and proportion of deciduous forest. Patch size and cover-type richness were the most commonly significant variables across spatial scales and across years. Individual species showed similar trends to that of the guild.

Dalke, Amber. 2008. **The relationship between *Trifolium* spp. abundance and environmental variables in East Bay grasslands**. Senior thesis, U.C. Berkeley, Berkeley, CA.

*Abstract-* California grasslands are complex, unique ecosystems comprised of many species of native and nonnative vegetation. One group of species widely used for range improvement is the *Trifolium* (wild clover) genus. However, *Trifolium* are among the more understudied vegetation types. *Trifoliums* are important to grassland ecosystems because they replenish deficient nitrogen in N-limited ecosystems and serve as forage when food is scarce. Therefore, understanding clover abundance in relation with environmental variables is important in the management of California's vulnerable grasslands. To examine these relationships an

## FINAL DRAFT REPORT

observational study was conducted in 63 plots within seven parks of the East Bay Regional Park District over three years (2005-2007). Variables tested relating to *Trifolium* abundance included geographical variables (slope, aspect, elevation, and heat load) and soil composition (total N, total C, P, X-Ca, sand, silt, clay, and pH). Of the *Trifolium* found, the majority came from a single nonnative species, *T. hirtum*. With the use of linear regressions, this study found *Trifolium* spp. abundance positively related to slope ( $\Sigma xR^2=0.22$ ,  $\Sigma xp=0.01$ ) and elevation ( $\Sigma xR^2=0.25$ ,  $\Sigma xp=0.02$ ) throughout the three-year time frame. Other relationships were observed including a positive relationship to silt ( $R^2=0.20$ ,  $p<0.01$ ) in 2005, a negative relationship to pH ( $R^2=0.10$ ,  $p=0.05$ ) in 2005, and negative relationships to total N ( $\Sigma xR^2=0.15$ ,  $\Sigma xp=0.04$ ) and total C ( $\Sigma xR^2=0.57$ ,  $\Sigma xp=0.06$ ) in 2006 and 2007. This research provides an important description of variables that may influence the abundance and distribution of *Trifolium* spp. in the East Bay.

### Gaber, Christine. 2008. **Small mammal habitat associations in East Bay Regional Park District grasslands.** Master's thesis, U.C. Berkeley, Berkeley, CA.

*Abstract-* The responses of California Valley Grassland vegetation and wildlife species to grazing by livestock and native herbivores are generally species-specific. However, few studies have examined the potentially different effects of sheep and cattle grazing on small mammals or the interactions between these species. This study investigated the relationships between livestock grazing, numerous community level environmental variables, and the presence of California vole (*Microtus californicus*), California ground squirrel (*Spermophilus beecheyi*) and valley pocket gopher (*Thomomys bottae*) within grassland habitats of Alameda and Contra Costa counties, California. The results of traditional logistic regression and non-parametric multiplicative regression in HyperNiche were compared. In addition, this study compared vegetation functional group characteristics of plots with different grazing regimes to test the hypothesis that selective foraging by livestock species can result in observable differences in grassland vegetation composition. Small mammal associations with grassland habitat elements and livestock species were species-specific. Habitat modeling results indicated that the presence of sheep grazing and abiotic factors, such as clay and a pH of approximately 5.8, best predicted the presence of California vole on the study plots. Percent clay in soils was negatively associated with vole presence. Location effects were important in determining the distribution of California ground squirrels as this species was concentrated at Vasco Caves and Brushy Peak. Variables identified in valley pocket gopher models as positively associated with species presence included elevation and native plant species cover. Cattle grazing and litter were negatively associated with pocket gopher presence. HyperNiche modeling results were similar to those derived through logistic regression. HyperNiche is an effective technique for identifying important predictor variables and interactions, and modeling wildlife habitat relationships without the constraints of traditional parametric techniques. While California ground squirrel distribution was fairly stable at the plot scale during the study, California voles colonized and abandoned multiple plots. Voles were the most sensitive of the three focal species to livestock grazing and the presence of other small mammals. I identified positive associations between voles and sheep grazing, and negative associations between voles and both cattle grazing and the presence of pocket gophers. Similar to other studies, I documented increased forbs on cattle grazed plots. However, spatial variability and differences among parks prevented conclusions about the effect of grazing regime on other vegetation characteristics. Interactions between livestock species and native herbivores also may complicate these results.

## FINAL DRAFT REPORT

Hopkinson, Peter, Matt Stevenson, Michele Hammond, Sasha Gennet, Devii Rao, and James W. Bartolome. 2008. Annual rye-grass: a new central California dominant? **Fremontia** 36: 20-24.

*Abstract-* Is exotic annual rye-grass coming to dominate San Francisco Bay Area annual grasslands? How might this affect native plant species, not to mention your grass pollen allergies? This article argues that yes, rye-grass is now a common dominant, and native plants, endangered butterflies, and people with hay fever may suffer as a result.

Bartolome, J.W., W.J. Barry, T. Griggs, and P. Hopkinson. 2007. Valley grassland. Chapter 14 in Barbour, Michael, Todd Keeler-Wolf, and Allan A. Schoenherr, eds. / **Terrestrial vegetation of California**. 3<sup>rd</sup> edition. Berkeley, CA: University of California Press.

Jackson, R.D. and J.W. Bartolome. 2007. Grazing ecology of California's grasslands. Pages 197-206 in: M.R. Stromberg, J.D. Corbin, and C.M. D'Antonio (eds.) / **California grasslands: ecology and management**. Berkeley, CA: University of California Press.

Huntsinger, L., J.W. Bartolome, and C.M. D'Antonio. 2007. Grazing management on California's Mediterranean grasslands. Pages 233-253 in: M.R. Stromberg, J.D. Corbin, and C.M. D'Antonio (eds.) / **California grasslands: ecology and management**. Berkeley, CA: University of California Press.

Gennet, Alexandra S. 2007. **Environmental determinants of plant community composition and songbird abundance in a California Coast Range Grassland.** Ph.D. dissertation, U.C. Berkeley, Berkeley, CA.

*Abstract-* I examined the effects of abiotic and biotic factors on plant community composition and how vegetation structure mediates abundance of grassland-specialist songbirds in a grassland east of San Francisco Bay, California. These biologically diverse and complex grasslands have experienced widespread invasion by non-native plants and are highly threatened by the effects of human development and land use in the rapidly urbanizing Bay Area. In addition, grassland songbirds are known to have been declining sharply for several decades nationwide, yet almost no studies have been conducted to better understand their breeding habitat requirements in California.

I used hierarchical agglomerative classification (cluster analysis) to develop a State-Transition model that describes plant community composition and inter-annual dynamics of this grassland. Eleven unique vegetation states are defined. The model can be used as a decision-support tool by resource managers and supports the differentiation of Coast Range grassland from other grassland types in California.

To better understand species distribution relative to land use and environmental factors, I analyzed the relationship between key plant species and topography, soil texture, soil chemistry, species richness, canopy structure, and livestock grazing using general linear models and logistic regression. The results suggest that Coast Range grasslands are a non-equilibrium ecosystem,

FINAL DRAFT REPORT

and that community composition is not driven by a single or small set of environmental factors, but rather that individual species have unique ecological niches in which they persist.

I examined the mediating effects of topographic site factors and vegetation structure on populations of four grassland songbirds, including Western Meadowlark (*Sturnella neglecta*), Horned Lark (*Eremophila alpestra*), Savannah Sparrow (*Passerculus sandwichensis*), and Grasshopper Sparrow (*Ammodramus savannarum*). The analysis showed that although they tend to co-occur at the landscape scale, each of the four members of the grassland songbird guild have unique habitat selection and utilization preferences at the community scale. Livestock grazing does not appear to negatively affect abundances of these birds. Conservation management for these species should include a patchwork, or mosaic, of habitat types.

Gea-Izquierdo, Guillermo, Sasha Gennet, and James W. Bartolome. 2007. Assessing plant-nutrient relationships in highly invaded Californian grasslands using non-normal probability distributions. **Applied vegetation science** 10: 343-350.

*Abstract-* Today, invasion of natural ecosystems by exotic species is an ecological issue of great concern in many regions of the world. California's grasslands are dominated by introduced Mediterranean annual plant species. Understanding the distribution of the remaining native species is of great ecological and conservation interest. We investigated the effects of soil characteristics and livestock grazing on native plant occurrence at 40 sites during the period 2003-2005. Low absolute cover (<5.8%) of native species resulted in strongly skewed, zero inflated data sets. To overcome problems in the analysis created by non-normality and correlations within plots, we used generalized models (GLM's and GLMM's), either with a Poisson or a Negative binomial distribution, to analyze native species richness and *Nassella pulchra* cover. Native species richness was highest in soils with low available nitrogen (high C:N), whereas *N. pulchra* cover was strongly associated with low phosphorus in sandy soils. Under current conditions, phosphorus seems to be a most critical factor influencing abundance of *N. pulchra*. We conclude that low-fertility soils may be providing refugia for native species in highly invaded California grasslands because the soils in which native species persist at low levels are below a threshold required for non-native annuals to completely dominate. The use of generalized models with non-normal probability distributions is uncommon in ecology whereas being quite common in other biological sciences. However, they are simple and well-suited to analysis of highly non-normal data sets, which strongly suggests valuable applications for ecological data analysis.

Sasha Gennet, Michele Hammond, and James W. Bartolome. 2007. Association of vegetation composition and canopy structure with songbirds in California Valley Grasslands. **Keeping landscapes working** 4: 2-3.

Robertson, Dina M. 2004. **Relationships between historic land use, plant species composition and environmental factors in the foothills south of Mount Diablo, California.** Master's thesis, U.C. Berkeley, Berkeley, CA.

*Abstract.* This study examined how historic dry-land farming and environmental factors correlate with grassland species composition in the foothills south of Mount Diablo in California. Dry-land farming, or farming without irrigation, was practiced in the Diablo Range from the 1800's until the 1990's. Aerial photographs, archival research and interviews with long time

FINAL DRAFT REPORT

residents were used to locate and confirm areas where past cultivation occurred. Archival research required extensive consideration to determine the chain of title and land use practices of the numerous owners, tenant farmers and ranchers that have populated the area since European settlement. Plant species cover was estimated using point line transects, and environmental data collected included percent slope, aspect, soil texture and chemistry. Ordination analysis was used to identify the relationships between environmental factors, historic land use and grassland plant composition. Results show that sites with similar cultivation history (1940 to 1990) have similar species composition, especially in occurrences of exotic invasive forbs, native perennial grasses and native annual forbs. The distribution of exotic invasive forbs occurred predominantly on historically cultivated sites and areas high in nutrients. Native perennial grasses and native annual forb species occurred on the uncultivated lower nutrient sites. Results also show that native annual forbs occur more often on north facing slopes, and exotic invasives on south facing slopes. No trends could be drawn for native perennial forbs, due to the low density of these species at the study site.

A.2 On-going student work and potential publications from EBRPD project

Terry, Chris. *In preparation.* The effect of landscape variables on Valley Grassland vegetation. Master's thesis, San Francisco State University, San Francisco, CA.

Gennet, Sasha, Michele Hammond, Erica Spotswood and James W. Bartolome. *In preparation.* Habitat Associations of California Grassland Songbirds.

*Abstract.* Grasslands are the most highly converted and least protected of all terrestrial habitats. Agricultural and urban conversion, altered fire regime, decimation of populations of native grazers, and introduction of domestic livestock and invasive plant species are among the impacts to grasslands occurring globally. Not surprisingly, grassland songbird communities throughout the western U.S. are declining faster than any other comparable bird guild. In California, however, this guild has been little studied and the species' habitat preferences are poorly known. California's Valley grassland is dominated by exotic annual grasses with occasional patches of native bunchgrass and forbs. We investigate the effects of native and exotic plant community composition, grassland structure, and presence of livestock grazing on the breeding season occurrence of three grassland bird species in California's Valley grasslands over a seven year period (2004-2010). These species include Western Meadowlark (*Sturnella neglecta*), Horned Lark (*Eremophila alpestra*), and Grasshopper Sparrow (*Ammodramus savannarum*). Using a generalized linear mixed model approach, we find that these three species have strong positive associations with native plant abundance. In grassland areas dominated by exotic plant cover, Horned Larks appear to also show a preference for grassland disturbance by livestock grazing especially in areas of low native plant cover. This study suggests that conserving California's grassland bird community requires further research into managing vegetation with livestock grazing as a tool to encourage native plant abundance and fine-scale vegetation heterogeneity.

FINAL DRAFT REPORT

**Appendix B: Oral presentations and posters from the East Bay Regional Park District Grassland Monitoring Project**

East Bay Grassland Monitoring Project: habitat associations of California grassland birds. Michele Hammond. Oral presentation at the U.C. Berkeley Wildlife-Fisheries & Conservation Biology Seminar, February 12, 2010, Berkeley, CA.

Grassland research in the East Bay. Michele Hammond. Oral presentation at the Global Environment Theme House Seminar, February 4, 2010, Berkeley, CA.

Grassland communities in East Bay Regional Parks. Peter Hopkinson. Oral presentation at the U.C. Berkeley Wildlife-Fisheries & Conservation Biology Seminar, January 22, 2010, Berkeley, CA.

Grassland birds of Alameda and Contra Costa counties. Michele Hammond. Oral presentation at the 5<sup>th</sup> Annual Summit of the California Rangeland Conservation Coalition, January 7, 2010, Sacramento, CA.

Native grassland species and livestock grazing: does it really matter? Michele Hammond. Oral presentation at the California Society for Ecological Restoration and California Native Grasslands Association SERCAL-CNGA 2009 Joint Conference, May 1, 2009, Folsom, CA.

Monitoring for grassland birds. Michele Hammond. Oral presentation at the Central Coast Rangeland Coalition Meeting, October 16, 2008, King City, CA.

Management implications of East Bay grasslands research 2003-2008. Peter Hopkinson. Oral presentation at the Central Coast Rangeland Coalition Meeting, October 16, 2008, King City, CA.

*Trifolium* spp. abundance in East Bay grasslands. Amber Dalke. Oral presentation at the U.C. Berkeley Environmental Science 196 Symposium, May 2008, Berkeley, CA.

Small mammal habitat associations in East Bay Regional Park District grasslands. Christine Gaber. Oral presentation at the 2008 Annual Conference of the Western Section of The Wildlife Society, February 7, 2008, Redding, CA.

Birds of the East Bay grasslands. Michele Hammond. Oral presentation at the 2008 Annual Conference of the Western Section of The Wildlife Society, February 7, 2008, Redding, CA.

*Lolium multiflorum*, Poaceae (annual ryegrass): a new regional grassland dominant. Peter Hopkinson, Matt Stevenson, Michele Hammond, Sasha Gennet, Devii Rao, Philip Brownsey, and James Bartolome. Poster at the 2<sup>nd</sup> Annual Symposium of the Northern California Botanists, January 2008, Chico, CA.

FINAL DRAFT REPORT

How the EBRPD project can help in the classification of California's grasslands. James Bartolome and Peter Hopkinson. Oral presentation to the Vegetation Committee of the California Native Plant Society, December 7, 2007, Berkeley, CA.

EBRPD project overview and research findings. Peter Hopkinson. Oral presentation to the U.C. Berkeley Range Ecology Group, December 6, 2007.

Small mammal habitat associations in East Bay Regional Park District grasslands. Christine Gaber. Oral presentation to the U.C. Berkeley Range Ecology Group, October 25, 2007.

Birds of the East Bay grassland. Michele Hammond. Oral presentation to the EBRPD Stewardship Seminar, October 30, 2007.

EBRPD project overview. James Bartolome. Oral presentation to the Regional Parks Association, October 15, 2007, Orinda, CA.

Birds of the East Bay grassland. Michele Hammond. Oral presentation at the California Partners in Flight (Cal-PIF) meeting, September 6-7, 2007.

Comparing spatial and temporal variability in the California annual grassland of the San Francisco Bay Area. Peter Hopkinson, James Bartolome, Reginald Barrett, Michele Hammond, Sasha Gennet, and Devii Rao. Oral presentation at the 60<sup>th</sup> Annual Meeting of the Society for Range Management, February 13, 2007, Reno, NV.

Association of vegetation composition and canopy structure with songbirds in California Valley Grasslands. Sheila Barry. Report on talk by Sasha Gennet for Society for Range Management symposium in June 2006 in: *Keeping landscapes working* 4: 2-3, Winter 2007.

A landscape analysis of grassland birds in oak woodland mosaics. Devii Rao. Oral presentation to the EBRPD Stewardship Seminar, October 19, 2006.

Grassland research in the East Bay Regional Park District. Peter Hopkinson. Oral presentation to the EBRPD Stewardship Seminar, October 19, 2006.

A landscape analysis of grassland birds in oak savanna mosaics. Devii Rao, Michele Hammond, Sasha Gennet, Peter Hopkinson, and James Bartolome. Oral presentation at the Sixth California Oak Symposium: Today's Challenges, Tomorrow's Opportunities, October 11, 2006, Rohnert Park, CA.

East Bay Regional Park District Vegetation and Wildlife Monitoring Study: Years 2002-2005. Michele Hammond and Sasha Gennet. Oral presentation to the EBRPD Natural and Cultural Resources Committee, August 2, 2006.

Effects of vegetation structure as a result of grazing on grassland songbirds. Sasha Gennet, Michele Hammond, and James W. Bartolome. Oral presentation at the Cal-Pac Section, Society

FINAL DRAFT REPORT

for Range Management Symposium held in conjunction with the Society for Conservation Biology Annual Meeting, June 28, 2006, San Jose, CA.

Effect of livestock grazing on plants and songbirds in Valley Grasslands, California, USA. S Gennet, JW Bartolome, M Hammond, and P Hopkinson. Poster at the 20<sup>th</sup> Annual Meeting of the Society for Conservation Biology, June 2006, San Jose, CA.

EBRPD Grasslands Monitoring Project overview. Peter Hopkinson and Sasha Gennet. Oral presentations for the University of California, Division of Agriculture and Natural Resources, 2006 Natural Resource Coordinating Conference Tour, March 15, 2006, Vasco Caves.

*Lolium multiflorum* population dynamics: preliminary assessment of a long-term monitoring study. Matthew Stevenson and James Bartolome. Poster at the 59<sup>th</sup> Annual Meeting of the Society for Range Management, February 2006, Vancouver, B.C., Canada.

Effects of grassland structure and landscape variables on grassland-obligate songbirds in Valley Grasslands, CA. Sasha Gennet and James Bartolome. Oral presentation at the 59<sup>th</sup> Annual Meeting of the Society for Range Management, February 2006, Vancouver, B.C., Canada. *1<sup>st</sup> place – Ph.D. Graduate Student Paper Contest.*

Habitat fragmentation and grassland diversity in Eastern Contra Costa County. Chris Terry. Oral presentation at the 8<sup>th</sup> Annual Conservation Biology Symposium, February 4, 2006, San Francisco State University.

Bird and vegetation communities of the East Bay grasslands. Sasha Gennet and James Bartolome. Oral presentation at the Wildlife and Conservation Biology Seminar Series, ESPM, U.C. Berkeley, November 18, 2005.

Effects of vegetation structure and species composition on grassland songbirds in EBRPD Valley Grasslands. Michele Hammond. Oral presentation to the EBRPD Stewardship Meeting, September 27, 2005.

East Bay Grassland Monitoring Program and vegetation of Sunol Regional Wilderness. Sasha Gennet and James Bartolome. Oral presentation for San Francisco Bay Area Grazing Lands Conference, September 15-16, 2005, Sunol Regional Wilderness and The Presidio, San Francisco.

EBRPD Grasslands Monitoring Project overview. Michele Hammond and James Bartolome. Oral presentation for the California Grazing Lands Coalition Tour, May 3, 2005, Sunol Regional Wilderness.

EBRPD Grasslands Monitoring Project overview. Michele Hammond and Peter Hopkinson. Oral presentation for Interpretive Staff training, EBRPD Interpretive and Recreation Services Department, March 23, 2005, Vasco Caves.

FINAL DRAFT REPORT

East Bay Regional Park District Vegetation and Wildlife Monitoring Study: Years 2002-2004. Michele Hammond and Andrew Scavullo. Oral presentation to the EBRPD Natural and Cultural Resources Committee, February 2005.

Effects of vegetation structure and species composition on grassland songbirds in Coast Range grasslands, CA. Sasha Gennet, Andrew Scavullo, Michele Hammond, and James Bartolome. Oral presentation at the 7<sup>th</sup> Annual Conservation Biology Symposium, January 2005, Stanford University.

East Bay Regional Park District Vegetation and Wildlife Monitoring Study. Peter Hopkinson and Michele Hammond. Oral presentations to the Plant Ecology and Ecosystem Sciences (PEES) Group, September-October, 2004, U.C. Berkeley.

Influence of historic land use and environmental factors on grassland species composition in the southern Diablo Foothills of California. Dina Robertson and James Bartolome. Oral presentation at the Ecology and Management of California Grasslands Conference, April 2-3, 2004, U.C. Berkeley.

EBRPD Grasslands Monitoring Project overview. Michele Hammond, Dina Robertson, and James Bartolome. Oral presentation at Elkhorn Slough Coastal Training Program Field Series. March 2004.

Historic land use on grassland in the southern Diablo Foothills of California. Dina Robertson and James Bartolome. Oral presentation at the 15th Annual International Society for Ecological Restoration Conference, November 2003, Austin, TX.

EBRPD monitoring project 2003-2003 functional group analysis. Aimee Betts. Oral presentation to the Plant Ecology and Ecosystem Sciences (PEES) Group, October 1, 2003, U.C. Berkeley.

Update for East Bay Regional Park District Grassland Monitoring Project. James Bartolome, Reginald Barrett, Karen Haubensak, and Dina Robertson. Oral presentation to the EBRPD Natural and Cultural Resources Committee, Fall 2003.

East Bay Regional Park District Vegetation and Wildlife Monitoring Pilot Study. James Bartolome, Reginald Barrett, Karen Haubensak, and Dina Robertson. Oral presentation to the EBRPD Natural and Cultural Resources Committee, February 14, 2003.

FINAL DRAFT REPORT

**Appendix C: Former interannual subset of plots (2003-2007)**

In reports prior to 2008, for interannual comparisons, we used the Valley grassland “interannual subset” of parks and plots, which consisted of data for 40 plots in 6 parks from 2003 through 2007 (Table C-1). See Section 4.0 of this report for details of the new interannual subset, 2005-2009.

**Table C-1:** Former Valley grassland “interannual subset” of plots, 2003-2007

2003-2007						
Brushy Peak	Chabot Ridge	Morgan Territory	Pleasanton Ridge	Sycamore Valley	Vasco Caves	
BP4	CR1	MT1	PR4	SV1	VC1	VC7
BP5	CR2	MT2	PR5	SV2	VC2	VC8
BP6	CR3	MT3	PR6	SV3	VC3	VC9
BP7	CR4	MT4	PR7	SV4	VC4	VC10
BP8	CR5	MT5	PR8	SV5	VC5	
BP9	CR6	MT6	PR9	SV6	VC6	



# Staff Report on Burrowing Owl Mitigation

State of California  
Natural Resources Agency  
**Department of Fish and Game**  
March 7, 2012<sup>1</sup>

---

<sup>1</sup> This document replaces the Department of Fish and Game 1995 Staff Report On Burrowing Owl Mitigation.

## TABLE OF CONTENTS

INTRODUCTION AND PURPOSE .....	1
DEPARTMENT ROLE AND LEGAL AUTHORITIES .....	2
GUIDING PRINCIPLES FOR CONSERVATION .....	3
CONSERVATION GOALS FOR THE BURROWING OWL IN CALIFORNIA .....	4
ACTIVITIES WITH THE POTENTIAL TO TAKE OR IMPACT BURROWING OWLS .....	4
PROJECT IMPACT EVALUATIONS .....	5
MITIGATION METHODS .....	8
ACKNOWLEDGEMENTS .....	15
REFERENCES .....	15
Appendix A. Burrowing Owl Natural History and Threats .....	20
Appendix B. Definitions .....	24
Appendix C. Habitat Assessment and Reporting Details .....	26
Appendix D. Breeding and Non-breeding Season Survey and Reports .....	28
Appendix E. Draft Example Components for Burrowing Owl Artificial Burrow and Exclusion Plans .....	31
Appendix F. Mitigation Management Plan and Vegetation Management Goals .....	33

## INTRODUCTION AND PURPOSE

Maintaining California's rich biological diversity is dependent on the conservation of species and their habitats. The California Department of Fish and Game (Department) has designated certain species as "species of special concern" when their population viability and survival is adversely affected by risk factors such as precipitous declines or other vulnerability factors (Shuford and Gardali 2008). Preliminary analyses of regional patterns for breeding populations of burrowing owls (*Athene cunicularia*) have detected declines both locally in their central and southern coastal breeding areas, and statewide where the species has experienced modest breeding range retraction (Gervais et al. 2008). In California, threat factors affecting burrowing owl populations include habitat loss, degradation and modification, and eradication of ground squirrels resulting in a loss of suitable burrows required by burrowing owls for nesting, protection from predators, and shelter (See Appendix A).

The Department recognized the need for a comprehensive conservation and mitigation strategy for burrowing owls, and in 1995 directed staff to prepare a report describing mitigation and survey recommendations. This report, "1995 Staff Report on Burrowing Owl Mitigation," (Staff Report) (CDFG 1995), contained Department-recommended burrowing owl and burrow survey techniques and mitigation measures intended to offset the loss of habitat and slow or reverse further decline of this species. Notwithstanding these measures, over the past 15+ years, burrowing owls have continued to decline in portions of their range (DeSante et al. 2007, Wilkerson and Siegel, 2010). The Department has determined that reversing declining population and range trends for burrowing owls will require implementation of more effective conservation actions, and evaluating the efficacy of the Department's existing recommended avoidance, minimization and mitigation approaches for burrowing owls.

The Department has identified three main actions that together will facilitate a more viable, coordinated, and concerted approach to conservation and mitigation for burrowing owls in California. These include:

1. Incorporating burrowing owl comprehensive conservation strategies into landscape-based planning efforts such as Natural Community Conservation Plans (NCCPs) and multi-species Habitat Conservation Plans (HCPs) that specifically address burrowing owls.
2. Developing and implementing a statewide conservation strategy (Burkett and Johnson, 2007) and local or regional conservation strategies for burrowing owls, including the development and implementation of a statewide burrowing owl survey and monitoring plan.
3. Developing more rigorous burrowing owl survey methods, working to improve the adequacy of impacts assessments; developing clear and effective avoidance and minimization measures; and developing mitigation measures to ensure impacts to the species are effectively addressed at the project, local, and/or regional level (the focus of this document).

This Report sets forth the Department's recommendations for implementing the third approach identified above by revising the 1995 Staff Report, drawing from the most relevant and current knowledge and expertise, and incorporating the best scientific information

**ECOLOGICAL IMPACTS OF RECREATIONAL USE OF TRAILS:  
A LITERATURE REVIEW**

Marilyn Jordan Ph.D. (mjordan@tnc.org)  
The Nature Conservancy, 250 Lawrence Hill Road  
Cold Spring Harbor, New York  
May 4, 2000

**SUMMARY:** Recreation such as hiking, jogging, horseback riding, and photography can cause negative ecological impacts to ecosystems, plants and wildlife including trampling, soil compaction, erosion, disturbance (due to noise & motion), pollution, nutrient loading, and introduction of non-native invasive plant species. Corridors such as trails and roads also cause habitat fragmentation and edge effects which may impact some plant and animal species. Thirty references are cited.

**SOURCES OF INFORMATION & SUBJECTS:** This document is based on references obtained from online data base searches, journal articles, information from internet searches, and personal communications. I found many articles on the impact of backcountry camping and horse packing in the western US (which I did not pursue or include in this review), quite a few articles on impacts of recreational use on birds, and one review paper on effects recreation on mammals, birds and herps. I found very few references on possible introduction of invasive non-native plants by hikers or horses, and almost nothing on bicycles or ATVs. Although the primary emphasis of this review is on recreational impacts from trail use, I have also included some articles on powerlines and small roads since they may cause habitat fragmentation and edge effects similar to those caused by trails, although on a somewhat larger scale.

**TYPES OF RECREATIONAL TRAIL USE (possible sources of stress/threats)**

Horseback riding  
Hiking, jogging, bird watching, photography  
Bicycling  
ATV use (all-terrain vehicles)

**STRESSES (all somewhat inter-related)**

Trampling  
Habitat disturbance or modification (noise & motion of recreational users, erosion, soil compaction etc.)  
Competition (from introduced exotics)  
Habitat fragmentation/edge effects (microclimatic change, reduced dispersal/migration, increased predation)  
Nutrient loading (horse and hiker manure & urine)  
Pollution (food waste, dangerous litter such as fishing line, plastic six-pack tops)

**TARGETS POTENTIALLY AFFECTED**

Ecological communities  
Plant species  
Birds  
Amphibians? Others?

**Trampling:** Effect of trampling is fairly limited, extending only about one meter from the trail's edge (Dale & Weaver 1974, Dawson et al. 1974). Trampling causes compaction of leaf litter and soil; compaction by horses is greater than by hikers (Dawson et al. 1974, Whittaker 1978). Some plant species decrease near trails, especially woody plants since they are brittle (like low shrubs or tree seedlings; Tonnesen and Ebersole 1997) but also more delicate herbaceous plants. Grasses and sedges are most tolerant of trampling (Dale & Weaver 1974, Douglas et al. 1975). Horses destroyed eight times as much cover and created an order of magnitude more bare ground than hikers (Nagy & Scotter 1974).

**Habitat disturbance (Trail width and depth):** Width increases linearly with logarithmic increase in number of users (width doubles with 10-fold increase in use). Trails in meadows are a little wider than trails in forests. "Trails with both horse and foot traffic are similar in width or slightly narrower than those receiving foot traffic alone" [NOT what we've observed in T. Roosevelt Co Park on Long Island]. .. Trails used by horses and people are deeper than those used by people alone" [agrees with Long Island observations] (Dale & Weaver 1974).

**Habitat disturbance (noise & motion):** Based on an extensive review of recreation effects on birds, Bennett and Zuelke (1999) concluded that disturbance from recreation clearly has at least temporary effects on behavior and movement of birds. Direct approaches caused greater disturbance than tangential approaches, rapid movement by joggers was more disturbing than slower hikers, children and photographers were especially disturbing to birds, horses did not seem to disturb birds, and passing or stopping vehicles were less disturbing than people on foot. No studies specifically addressing bicycles were found. Road noise has been shown to negatively affect birds (reduced nesting, etc.) at distances of up to 1,000 m (Forman 1998 ESA talk), so noise from trail users might also affect birds but presumably over shorter distances. Boyle and Samson (1985) reviewed 166 articles containing original data and found negative impacts reported in 81% of them.

**Competition (from introduced exotics):** Few references are available on introduction of exotics by hikers and horses, and is an area in need of more research (Williams & Conway-Durver 1998). Dale & Weaver (1974) studied hiking and horse trails in the Northern Rocky Mountains, and reported that some plant species appeared only at trail sides (invaders) and several of these were non-native. He speculated that these species may be favored by microclimatic edge effects and nutrient enrichment from horse urine and manure. Benninger (1989) reported that horse manure contained viable seeds of at least eight exotic species, and she presumed that horse scat may be a dispersal mechanism for some exotic species. In her study of forested areas in Rocky Mountain National Park she found significantly less plant cover, and more exotic plant species near trail edges; exotic species tended to be more abundant on more heavily used trails; and total species richness (but not exotic richness) was significantly negatively correlated with distance from trailheads (Benninger-Truax et al. 1992). They inferred that trail corridors were serving as conduits for movement of species (Benninger-Truax et al. 1992). Exotic species richness in Montana grasslands was highest near road edges and steadily declined out to 100 m, the most distant sampling position (Tyser and Worley 1992). However, the gradient for three back-country trails

was much less pronounced due to high numbers of exotic species at 100 m distant. They believed the widespread distribution of exotic grasses was due to past pasturing of concession horses. The two most abundant exotic species near both roads and trails were timothy (*Phleum pratense*) and bluegrass (*Poa pratensis*), species that had been included in past roadside seeding (and are common in pastures and hay).

Timothy is an aggressive exotic at Yellowstone (Meyers-Rice pers. comm.). Other grasses common in pastures and hay that can be weedy are *Lolium multiflorum* and *Lolium perenne* (rye grass); common wildland weeds closely related to cultivated oats are *Avena fatua* and *A. barbata* (Meyers-Rice pers. comm.). In addition to spreading weeds in their manure, horses may collect and spread weed seeds via their tails (Meyers-Rice pers. comm.).

In T Roosevelt Co Park, Montauk LI, NY, several exotic grasses appear more abundant along the sides of horse trails including velvet grass (*Holcus lanatus*), bluegrass, fescue, orchard grass and timothy (Jordan, unpub. obs.). These grasses are common in pastures and hay, and probably have been introduced by the horseback riding concession. Bentgrass (*Agrostis alba/tenuis*), is found throughout the park and in essentially all grasslands on Long Island. Bentgrass likely was an early introduction by European settlers.

*Lespedeza cuneata* (Chinese lespedeza) occurs along a trailside in pine barrens forest in the Peconic River Headwaters, LI, NY near but outside of a DEC "food plot" where this invasive exotic had been planted (cover for released pen-reared game birds)(M. Jordan unpub. obs.). The vector for seed movement is unknown.

It is not possible to tell from reports of weeds along trail sides if the weedy species were actually out-competing native species, or if they were just "filling in" ecological space opened up by reduction of native species due to unfavorable environmental change (due to trampling, microclimate change, etc.). Some of both probably may occur, depending on circumstances. It is also not possible to tell how the weeds got there, although hikers could conceivably carry weed seeds on their clothes and shoes and move them to new areas (potential research study - stop hikers at trail heads and scrape their boots! Measure weed abundance relative to distance from trailheads). A correlation analysis of literature from 184 studies from around the world found that the number of exotic species in nature reserves increased with the number of visitors, but no conclusions could be drawn about roles of dispersal and disturbance since other variables were involved (Lonsdale 1999).

**Habitat fragmentation/edge effects:** Microclimatic changes (increased sunlight, increased rainfall due to reduced canopy interception, increased wind, decreased humidity, altered temperature regime, etc.) have been documented within the edges of forests adjacent to clearings (Chen et al. 1999, Saunders et al 1991, Wildove et al. 1986) and similar effects probably could occur along a forest trail wide enough to open up the canopy (Cole, N. 1978, Dale and Weaver 1974). These microclimatic alterations could result in plant species changes and might also affect wildlife. Several references document negative impacts on breeding bids of recreational trails as narrow as 1-3m wide in forest and grasslands (Miller et al. 1998, Hickman 1990), as well as by dirt

roads and powerlines (Kroodsmas 1982, Askins 1994). The negative impacts included decreased nesting near trails, altered bird species composition near trails, and increased nests predation by cowbirds, skunks, racoons and foxes using the clearings as corridors. These effects are possible even if the forest canopy is not opened by the trail (Hickman 1990).

Trails also might impede movement and dispersal of some animals that are reluctant to cross openings, especially those with exposed bare soil.

**Nutrient enrichment:** Nutrient enrichment from horse manure and urine is a likely factor that could favor invasion of weedy species along horse trails. Research has shown that experimentally fertilized grasslands undergo a dramatic species change resulting in increased abundance of non-native grasses, decline of native grasses and decreased diversity (Wedin & Tilman 1996).

#### REFERENCES CITED

- Askins, R. A. 1994. Open corridors in a heavily forested landscape; impact on shrubland and forest interior birds. *Wildl. Soc. Bull.* 22:339-347.
- Bennett, K. A. and E. Zuelke. 1999. The effects of recreation on birds: a literature review. Delaware Natural Heritage Program, Smyrna, DE 19977
- Benninger, M. C. 1989. Trails as conduits of movement for plant species in coniferous forests of Rocky Mountain National Park, Colorado. Masters thesis, Miami University, Oxford, Ohio. As cited in Benninger-Truax et al. 1992.
- Benninger-Truax, M., J. L. Vankat and R. L. Schaefer. 1992. Trail corridors as habitat and conduits for movement of plant species in Rocky Mountain National Park, Colorado. *Landscape Ecology* 6(4): 269-278.
- Boyle, S. A. and F. B. Samson. 1985. Effects of nonconsumptive recreation on wildlife: a review. *Wildl. Soc. Bull.* 13:110-116.
- Chen, J., S. C. Saunders, T. R. Crow., R. J. Naiman, K. D. Brososke, G. D. Mroz, B. L. Brookshire, and J. F. Franklin. 1999. Microclimate in forest ecosystem and landscape ecology. *BioScience* 49: 288-297.
- Cole, D. N. 1978. Estimating the susceptibility of wildland vegetation to trailside alteration. *J. Appl. Ecol.* 15:281-286. (abstract by USDA Forest Service; trampling).
- Dale, D. and T. Weaver. 1974. Trampling effects on vegetation of the trail corridors of north Rocky Mountain forests. *J. Applied Ecology* 11:767-772.
- Dawson, J. O., P. N. Hinz and J. C. Gordon. Hiking trail impact on Iowa stream valley forest preserves. *Iowa State J. Res.* 48:329-337. (abstract by USDA Forest Service).

Douglas, G. W., J. S. Nagy and G. W. Scotter. 1975. Effects of human and horse trampling on natural vegetation. Waterton Lakes National Park, unpubl. Rep. Can. Wildl. Serv., edmonton, Alta. 139 p. (abstract by USDA Forest Service).

Fletcher R.J. Jr.; McKinney S.T.; Bock C.E. 1999. Effects of recreational trails on wintering diurnal raptors along riparian corridors in a Colorado grassland. *Journal of Raptor Research*, 33:233-239

Hickman, S. 1990. Evidence of edge species attraction to nature trails within deciduous forest. *Natural Areas Journal* 10:3-5.

Kroodsma, R. L. 1982. Edge effect on breeding forest birds along a power-line corridor. *Journal of Applied Ecology* 19:361-370.

Lonsdale, W. M. 1999. Global patterns of plant invasions and the concept of invasibility. *Ecology* 80: 1522-1536.

Miller, S. G., R. L. Knight and C. K. Miller. 1998. Influence of recreational trails on breeding bird communities. *Ecological Applications* 8:162-169.

Nagy, J. A. S., and G. W. Scotter. 1974. Quantitative assessment of the effects of human and horse trampling on natural areas, Waterton Lakes National Park, unpubl. Rep. Can. Wildl. Serv., edmonton, Alta. 145 p. (abstract by USDA Forest Service).

Saunders, D. A., R. J. Hobbs and C. R. Margules. 1991. Biological consequences of ecosystem fragmentation: A review. *Conserv. Biol.* 5:18-32. .

Tonnesen, A.S. and Ebersole, J.J. 1997. Human trampling effects on regeneration and age structures of *Pinus edulis* and *Juniperus monosperma*. *Great Basin Naturalist*, 57:50-56, 1997

Tyser, R. W. and C. A. Worley. 1992. Alien flora in grasslands adjacent to road and trail corridors in Glacier National Park, Montana (U.S.A.). *Conservation Biology* 6:253-262.

Wedin, D. A. and D. Tilman. 1996. Influence of nitrogen loading and species composition on the carbon balance of grasslands. *Science* 274: 1720-1723.

Whittaker, P. L. 1978. Comparison of surface impact by hiking and horseback riding in the Great Smoky Mountains National Park. *Manage. Rep.* 24, 32 p. U.S. Dep. Interior, Natl. Park Serv., Southeast Reg.

Wilcove, D. S, C. H. McLellan and A. P. Dobson. 1986. Habitat fragmentation in the temperate zone. Pp. 237-256 In M. E. Soule (ed), *Conservation Biology: The Science of Scarcity and Diversity*. Sinauer Associates, Sunderland, MA.

---

Williams, B. and L. Conway-Durver. Horse trails in ecological reserves. National Symposium on Horse Trails in Forest Ecosystems. October 18-21, 1998. Clemson University, SC.

---

#### OTHER REFERENCES NOT OBTAINED, OR NOT USED, FOR THIS REVIEW

Bates, G. 1935. The vegetation of footpaths, sidewalks, cart-tracks and gateways. *J. Ecol.* 23:470-487.

Meinecke, E. 1929. The effects of excessive tourist travel on the California redwood parks. California State Printing office, Sacramento.

Westhoff, V. 1967. The ecological impact of pedestrian, equestrian and vehicular traffic on flora and vegetation. *Proc. IUCN, N.S.* 7, 218-23.

Hickman, S. 1990. Evidence of edge species attraction to nature trails within deciduous forest. *Natural Areas Journal* 10:3-5.

Hammitt, W. E. and D. N. Cole. 1998. *Wildland Recreation: Ecology and Management* (Second Edition). New York: John Wiley & Sons.

Knight R. L. and K. J. Gutzwiller, eds. 1995. *Wildlife and Recreationists: Coexistence Through Management and Research*. Washington, DC: Island Press. [ contains almost no information on impacts of recreational hiking, horseback riding, or other trail impacts].

Liddle, M. J. 1997. *Recreation Ecology: The Ecological Impact of Outdoor Recreation and Ecotourism*. London: Chapman and Hall.

California Wildlife Habitat Relationships System  
California Department of Fish and Game  
California Interagency Wildlife Task Group

---

## Coastal Oak Woodland

Updated by: CWHR Staff, April 2005

V. L. Holland

### Vegetation

**Structure.** Coastal oak woodlands are extremely variable. The overstory consists of deciduous and evergreen hardwoods (mostly oaks 4.5-21 m (15 to 70 ft) tall sometimes mixed with scattered conifers. In mesic sites, the trees are dense and form a closed canopy. In drier sites, the trees are widely spaced, forming an open woodland or savannah. The understory is equally variable. In some instances, it is composed of shrubs from adjacent chaparral or coastal scrub which forms a dense, almost impenetrable understory. More commonly, shrubs are scattered under and between trees. Where trees form a closed canopy, the understory varies from a lush cover of shade-tolerant shrubs, ferns, and herbs to sparse cover with a thick carpet of litter. When trees are scattered and form an open woodland, the understory is grassland, sometimes with scattered shrubs. The interrelationships of slope, soil, precipitation, moisture availability, and air temperature cause variations in structure of coastal oak woodlands. These factors vary along the latitudinal, longitudinal and elevational gradients over which coastal oak woodlands are found.

**Composition.** Composition of both overstory trees and understory of coastal oak woodland varies and reflects the environmental diversity over which this habitat occurs. In the North Coast Range south to Sonoma County, coast live oak often does not dominate. Where Oregon white oak, California black oak, canyon live oak, madrone and interior live oak dominate, the habitat is generally considered Montane Hardwood (MHW).

From Sonoma County south, the coastal oak woodlands are usually dominated by coast live oak. In many coastal regions, coast live oak is the only overstory species. In mesic sites, trees characteristic of mixed evergreen forests mix with coast live oak, such as California bay, madrone, tanbark oak, and canyon live oak. On drier, interior sites, coast live oak mixes with valley oak, blue oak, and foothill pine.

Typical understory plants in dense coast live oak woodlands are shade tolerant shrubs such as California blackberry, creeping snowberry, toyon, and herbaceous plants such as bracken fern, California polypody, fiesta flower, and miner's lettuce. In drier areas where oaks are more widely spaced, the understory may consist almost entirely of grassland species with few shrubs, although a diversity of shrubs can occur under and between the trees with a sparse herbaceous cover. Where coast live oak woodlands intergrade with chaparral, species such as greenleaf manzanita, chamise, gooseberries, currants, and ceanothus species form the understory. Where the habitat intergrades with coastal scrub,

typical understory species are bush monkeyflower, coyote brush, black sage, and California sagebrush.

From Ventura County south, floristic changes occur in coastal oak woodlands. There is little change in introduced species of forbs and grasses, but the native shrubs and herbs are more typical of southern California. The dominant trees of the southern oak woodlands are Engelmann oak, coast live oak, interior live oak, and California walnut. These occur in various mixtures, depending on location. Engelmann oak, a semi-deciduous white oak, is an ecological homologue of blue oak and replaces it in southern California. Interior live oak usually occurs at higher elevations in the interior mountains, often associated with rock outcrops. Coast live oak grows in moister sites, especially near the coast, but extends farther inland in southern California than it does elsewhere in its range. It often forms mixed stands with Engelmann oak in the foothills of the Peninsular Ranges. California walnut is locally dominant, with coast live oak between Santa Barbara and Orange Counties (Jepson 1910, Wieslander 1934 a, b, Swanson 1967). Coulter pine is sometimes a component of the coastal oak woodlands in mesic sites of southern and central California.

**Other Classifications.** Coastal oak woodland, as treated here, combines diverse oak-dominated vegetation types into one. For example, this habitat or portions of it are included in the Northern Oak Woodland, Southern Oak Woodland and Foothill Woodland of Munz (1973) (No Munz 1973 in Habitat Lit Cite.) and of Griffin (1977); the Southern Oak Forests of Küchler (1977); the Coast Live Oak and Engelmann Oak of Parker and Matyas (1981); the Southern Oak Woodland, Northern Oak Woodland and California Coast Live Oak Forest of Cheatham and Haller (1975); the Coast Live Oak and Engelmann Oak of Paysen, et al. (1980); the California Coast Live Oak and Mixed Forest Land of the Society of American Foresters classification (Eyre 1980); the Deciduous Forest Land, Evergreen Forest Land and Mixed Forest Land of the U.S.G.S. system (Anderson et al. 1976); and the Coastal Live Oak Woodland, Northern Oak Woodland and Southern Oak Woodland of Holland et al. (1983) and Holland and Keil (1987).

### Habitat Stages

**Vegetation Changes--1;2-5:S-D.** Like other oak woodlands in California, successional trends in the COW have not been studied and remain largely unknown. Some species of deciduous oaks have not successfully reproduced for over 60 years (White 1966, Brooks 1971, Griffin 1971, 1976, Fieblekorn 1972, Snow 1972, Holland 1976). Evergreen oaks have been more successful and as a result appear to be gaining dominance in some areas (Griffin 1977). In other locations, it appears that coast live oak is being replaced by California bay as a result of grazing pressures and lack of successful regeneration (McBride 1974).

Jepson (1910), Cooper (1922), and Wells (1962) (Wells 1962 not in Habitat Lit Cite.) suggested that Indian burning in the past was important in maintaining some open stands of coastal oak woodland. Natural and manmade fires may still be important in some areas. Southern oak woodlands have apparently experienced an increase in

periodicity of fires in recent years. Studies indicate that Engelmann oak and coast live oak are able to survive most fires (Snow 1979).

Most coastal oak woodlands are comprised of medium to large trees with few seedlings and saplings, especially in heavily grazed areas. Regeneration of most oaks in the coastal oak woodlands has not been studied thoroughly, but it is generally considered that they do not have the serious regeneration problems found with blue oak and valley oak. However, Engelmann oak is not adequately reproducing itself for reasons similar to those of blue oak.

**Duration of Stages--** Coastal oak woodlands are comprised of slow growing, long-lived trees, so succession requires a long time. The actual time is variable and depends on local environmental conditions. Development of mature, large trees requires 60 to 80 years, and most of the trees of the coastal oak woodlands are at least this old. The best information available on succession in oak woodland, is historical. Since the Mission Period (1769-1824) and especially during the last century, marked changes have occurred in the coastal oak woodlands of California due to the introduction of domestic grazing animals and accompanying land management practices. The change in herbaceous understory from perennial species to aggressive, introduced annuals may have resulted in young oaks being out-competed for limited supplies of nutrients and moisture (Twisselmann 1967, Holland 1976). These changes have resulted in retrogressive succession in which well-developed oak woodlands regress to open woodlands or savannas and eventually to disturbed grasslands. Even ubiquitous pioneer shrubs fail to become established as successfully in disturbed grassland. Woodcutting has also had an impact and in local areas has created "stump-prairies" because oaks have not successfully reinvaded after removal (Wells 1962). Land clearing and urban expansion have also destroyed extensive stands of coastal oak woodland.

## Biological Setting

**Habitat--** Coastal oak woodlands are common to mesic coastal foothills of California. The woodlands do not form a continuous belt, but occur in a mosaic closely associated with MCH CSC and AGS. Where moisture conditions are more favorable, such as north facing slopes and canyons, or higher elevations, COW grades into MHC or sometimes MCN habitats. From the coast toward the hotter, drier interior portions of the north and south coast range, COW grades into foothill woodlands (BOW), forming indistinct ecotones where the two overlap.

**Wildlife Considerations --** Coastal oak woodlands provide habitat for a variety of wildlife species. Barrett (1980) reports that at least 60 species of mammals may use oaks in some way. Verner (1980) reports 110 species of birds observed during the breeding season in California habitats where oaks form a significant part of the canopy or subcanopy. Quail, turkeys, squirrels, and deer may be so dependent on acorns in fall and early winter that a poor acorn year can result in significant declines in their populations (Shields and Duncan 1966, Graves 1977, Schitoskey and Woodmansee 1978). Therefore,

many wildlife managers are concerned over the continuing loss of coastal oak woodland habitats as a result of man's activities.

## Physical Setting

Coastal oak woodlands occupy a variety of mediterranean type climates that vary from north to south and west to east. (The climate becomes hotter and drier toward the south and east.) Precipitation occurs in the milder winter months, almost entirely as rainfall, followed by warm to hot, dry summers. Near the coast, the summers are tempered by fogs and cool, humid sea breezes. Mean annual precipitation varies from about 100 cm (40 in) in the north to about 38 cm (15 in) in southern and interior regions. Mean minimum winter temperatures are 2 to 7 C (29 to 44 F), and the mean maximum summer temperatures are 24 to 36 C (75 to 96 F). The growing season ranges from six months (180 frost-free days) in the north to the entire year in mild coastal regions to the south. The soils and parent material on which coastal oak woodlands occur are extremely variable. In San Luis Obispo County alone they are found on over fifteen different parent materials ranging from unconsolidated siliceous sand to diatomaceous earth to serpentinite to volcanic ash and basalt (Wells 1962). Coastal oak woodlands generally occur on moderately to well-drained soils that are moderately deep and have low to medium fertility.

## Distribution

Coastal oak woodlands occur in the coastal foothills and valleys from Trinity to Humboldt counties south through the coastal regions of the northern and southern coast range, the transverse and peninsular range of southern California. They extend beyond the counties of southern California into coastal Baja California, where they reach their southern limit (Griffin and Critchfield 1972). They occur at elevations from just above sea level near the immediate coast to about 1525 m (5000 ft) in the interior regions, especially in southern California.

## Literature Cited

- Anderson, J. R., E. E. Hardy, J. T. Roach, and R. E. Witmer. 1976. A land use and land cover classification system for use with remote sensor data. U.S. Dep. Interior, Geol. Surv., Prof. Pap. 964.
- Barrett, R. H. 1980. Mammals of California oak habitats: management implications. Pages 275-291 In T. R. Plumb, tech. coord. Ecology, management, and utilization of California oaks. U.S. Dep. Agric., For. Serv. (Berkeley, Calif.), Gen. Tech. Rep. PSW-44.
- Brooks, W. H. 1971. A quantitative ecological study of the vegetation in selected stands of the grass-oak woodland in Sequoia National Park, California. Progr. Rep., Sequoia-Kings Canyon Nat'l. Park, Three Rivers, Calif.

- Cheatham, N. H., and J. R. Haller. 1975. An annotated list of California habitat types. Univ. of California Natural Land and Water Reserve System, unpubl. manuscript
- Cooper, W. S. 1922. The broad-sclerophyll vegetation of California. Carnegie Inst. Wash. Publ. 319.
- Eyre, F. H., ed. 1980. Forest cover types of the United States and Canada. Soc. Amer. Foresters, Washington D.C.
- Fieblekorn, C. 1972. Interim report of oak regeneration study. Unpub. Rep., Natur. Resources Cons. Office, Hunter Liggett Mil. Reserv., Jolon, Calif.
- Griffin, J. R. 1967. Soil moisture vegetation patterns in northern California forests. U.S. Dep. Agric., For. Serv. (Berkeley, Calif.), Res. Pap. PSW-46.
- Griffin, J.R. 1971. Oak regeneration in the upper Carmel Valley, California. Ecology 52:862-868.
- Griffin, J. R. 1976. Regeneration in *Quercus lobata* savannas, Santa Lucia Mountains, California. Amer. Midl. Nat. 95:422-435.
- Griffin, J. R. 1977. Oak woodland. Pages 383-415 In M. G. Barbour and J. Major, eds. Terrestrial vegetation of California. John Wiley and Sons, New York.
- Griffin, J. R., and W. B. Critchfield. 1972. The distribution of forest trees in California. U.S. Dep. Agric., For. Serv. (Berkeley, Calif.), Res. Pap. PSW-82.
- Holland, V. L. 1976. In defense of blue oaks. *Fremontia* 4:3-8.
- Holland, V. L., and D. Keil. 1987. California vegetation. El Corral Bookstore, California Polytechnic State Univ., San Luis Obispo.
- Holland, V. L., D. J. Keil, D. R. Walters, and M. G. McLeod. 1983. Major plant communities of California. El Corral Bookstore, California Polytechnic State Univ., San Luis Obispo.
- Jepson, W. L. 1910. The silva of California. Vol. 2. Univ. of California Mem. Kuchler, A. W. 1977. Appendix: the map of the natural vegetation of California. Pages 909-938 In M. G. Barbour and J. Major, eds, Terrestrial vegetation of California. John Wiley and Sons, New York.
- Holland, V. L. 1976. In defense of blue oaks. *Fremontia* 4:3-8.
- McBride, J. 1974. Plant succession in the Berkeley Hills, California. *Madroño* 22:317-329.
- Munz, P. A. 1974. A flora of southern California. Univ. of California Press, Berkeley.
- Parker, I., and W. J. Matyas. 1981. CALVEG: a classification of Californian vegetation. U.S. Dep. Agric., For. Serv., Reg. Ecol. Group, San Francisco.
- Paysen, T. E., J. A. Derby, H. Black, Jr., V. C. Bleich, and J. W. Mincks. 1980. A vegetation classification system applied to southern California. U.S. Dep. Agric., For. Serv., (Berkeley, Calif.) Gen. Tech. Rep. PSW-45.
- Schitoskey, F., Jr., and S. R. Woodmansee. 1978. Energy requirements and diet of California ground squirrel. *J. Wildl. Manage.* 42:373-382.
- Shields, P. W., and D. A. Duncan. 1966. Fall and winter food of California quail in dry years. *Calif. Fish and Game* 52:275-282.
- Snow, G.E. 1972. Some factors controlling the establishment and distribution of *Quercus agrifolia* Nee and *Q. engelmannii* Greene in certain Southern California oak woodlands. Ph.D. dissertation, Oregon State Univ., Corvallis.



- Snow, G. 1979. The fire resistance of Engelmann and coast live oak seedlings. Pages 62-67 in T. R. Plumb, tech. coord. Ecology, management and utilization of California oaks. U.S. Dep. Agric., For. Serv. (Berkeley, Calif.) Gen. Tech. Rep. PSW 44
- Swanson, C. J. 1967. The ecology and distribution of *Juglans californica* in southern California. M. A. thesis, California State Univ., Los Angeles.
- Twisselman, E. C. 1967. A flora of Kern Co., California Wassmann J. Biol. 25:1-395.
- Verner, J. 1980a. Birds of California oak habitats: management implications. Pages 246-264 In T. R. Plumb, tech. coord. Ecology, management, and utilization of California oaks. U.S. Dep. Agric., For. Serv. (Berkeley Calif.) Gen. Tech. Rep. PSW-44.
- White, K. L. 1966. Structure and composition of foothill woodland in central coastal California. Ecology 47:229-237.
- Wieslander, A. E. 1934a. Vegetation types of California, Pasadena Quadrangle (162D). U.S. Dep. Agric., For. Serv. map.
- Wieslander, A. E. 1934b. Vegetation types of California, Pomona Quadrangle (163C). U.S. Dep. Agric., For. Serv. map.

## MEASURING HABITAT QUALITY: A REVIEW

MATTHEW D. JOHNSON<sup>1</sup>

*Department of Wildlife, Humboldt State University, 1 Harpst Street, Arcata, CA 95521*

**Abstract.** Understanding habitat quality for birds is crucial for ecologists and managers, but few papers have explored the advantages and disadvantages of different ways to measure it. In this review I clarify terminology and distinguish habitat quality from related terms, differentiate habitat quality at the levels of individual birds and populations, and describe different field methods for measuring habitat quality. As much as feasible, biologists concerned with habitat quality should emphasize demographic variables while recognizing that reproduction, survival, and abundance may not all be positively correlated. The distribution of birds can also reveal habitat quality (e.g., through patterns of habitat selection), but researchers should first investigate how closely their subjects follow ideal distributions because numerous ecological factors can lead birds to select poor and avoid rich habitats. Measures of body condition can provide convenient measures of habitat quality, but to be useful they must be a consequence, rather than a cause, of habitat selection. Habitat ecologists should use caution before relying on shortcuts from more labor-intensive demographic work. To increase the reliability of our habitat quality measurements, we should work to develop new methods to assess critical assumptions of nondemographic indicators, such as whether birds follow ideal distributions under natural conditions and whether spatial variation in body condition manifests in differential fitness.

**Key words:** *body condition, demography, distribution, habitat preference, habitat quality, habitat selection, habitat suitability.*

### Mediciones de Calidad de Hábitat: Una Revisión

**Resumen.** Entender la calidad del hábitat de las aves es crucial para los ecólogos y los encargados del manejo ambiental, pero pocos artículos han explorado las ventajas y desventajas de distintos métodos para medirla. En esta revisión, aclaro la terminología y diferencio la calidad del hábitat de otros términos relacionados, distingo la calidad del hábitat a nivel de aves individuales y de poblaciones y describo diferentes métodos de campo para medir la calidad del hábitat. En la medida de lo posible, los biólogos interesados en la calidad del hábitat deberían enfatizar variables demográficas, y tener en cuenta que la reproducción, supervivencia y abundancia podrían no estar correlacionadas. La distribución de las aves también puede indicar la calidad del hábitat (e.g., a través de patrones de selección de hábitat), pero los investigadores deberían primero investigar hasta qué punto sus sujetos de estudio presentan distribuciones ideales, debido a que muchos factores ecológicos pueden llevar a que las aves seleccionen ambientes pobres y eviten ambientes ricos. Las medidas de condición corporal también pueden representar medidas convenientes de la calidad del hábitat, pero para ser útiles deben ser una consecuencia y no una causa de la selección de hábitat. Los ecólogos ambientales deben tener cuidado al basarse en estudios rápidos en lugar de realizar trabajos demográficos más laboriosos. Para incrementar la confiabilidad de nuestras medidas de calidad de hábitat, debemos desarrollar nuevos métodos para abordar las suposiciones más importantes de los indicadores no demográficos, tales como si las aves presentan distribuciones ideales en condiciones naturales, y si la variación espacial en la condición corporal se traduce en una adecuación biológica diferencial.

### INTRODUCTION

Local habitat affects the fitness of animals through variation in resources and environmental conditions (Bernstein et al. 1991, Pulliam 2000). Spatial and temporal variation in

habitat conditions thus generate strong selective pressure for habitat selection (Cody 1985), which in turn influences reproduction and survival of individual birds (Brown 1969, Fretwell and Lucas 1970, Sutherland and Parker 1985), and contributes to the regulation of bird populations (Newton 1998). It is no surprise, then, that ornithologists have long recognized the need to understand variation in habitat for birds (Block and Brennan 1993).

Manuscript received 1 May 2006; accepted 21 March 2007.

<sup>1</sup> E-mail: mdj6@humboldt.edu

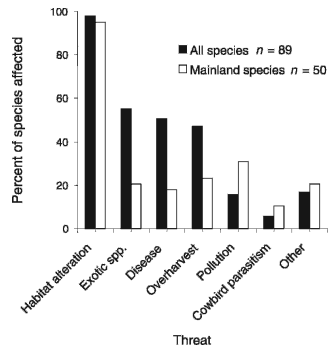


FIGURE 1. Causes of endangerment of bird species listed as threatened and endangered in lands managed by the United States. "All species" includes data from Hawaii, Puerto Rico, American Samoa, and other islands; "mainland species" excludes those from islands. A species can have more than one cause of endangerment. Note that habitat alteration—which includes habitat loss, degradation, and conversion—is by far the greatest threat, followed by interactions with exotic species, which often invade following habitat alteration. The data in this figure were obtained from the Federal Register and cover all species listed as of 5 April 2006.

Indeed, loss and degradation of habitat is the greatest threat to wild bird species (Fig. 1). Limited funding requires prioritizing habitats based on their value for particular research questions or management objectives, which often revolve around focal species such as those of special conservation concern. How can habitats be judged for their importance to birds; how can good, marginal, and poor habitats be distinguished? That is, how can we assess the quality of habitats?

Van Horne (1983) provided a foundational treatment of habitat quality for vertebrates and cautioned that the density of animals in a habitat can, in some cases, be a misleading indicator of habitat quality. Since the publication of her influential and oft-cited paper (Bock and Jones 2004), biologists have recognized that robust measures of habitat quality require a thorough unraveling of habitat-specific measures of demography (i.e., density, reproduction, and survival measures in each habitat

considered). However, time and monetary constraints rarely allow all of these measures to be obtained, so biologists often rely on other measures to help distinguish rich and poor habitats, spawning related terms and concepts such as habitat carrying capacity, habitat preference, habitat occupancy, and so on. In many cases, habitat quality is regarded as a somewhat vague concept enabling habitat patches to be ranked, and it is often simplified into an index ranging from 0 to 1, as in the U.S. Fish and Wildlife Service's "habitat suitability index" (HSI) models (Schamberger et al. 1982). Despite its importance to the discipline and the myriad recognized ways it can be measured, there have been few reviews of habitat quality and how it can be quantified by ornithologists (but see introductions of James 1971, Bernstein et al. 1991, Block and Brennan 1993, Sergio and Newton 2003, Pidgeon et al. 2006). Here, I describe ways of conceptualizing and measuring habitat quality. Specifically, I have four objectives: (1) clarify terminology and distinguish habitat quality from related terms, (2) differentiate habitat quality at individual and population levels, (3) outline various ways of measuring habitat quality for wild birds, recognizing methods that emphasize demographic, distributional, and individual condition variables, and (4) review how ornithologists have measured habitat quality in the last two decades.

#### BACKGROUND AND TERMINOLOGY

Hall and her colleagues (Hall et al. 1997, Morrison and Hall 2002) argued that some of the confusion surrounding habitat's role in animal ecology stems from inconsistent and imprecise use of terms, which is unsurprising given habitat's long history in ecology (Grinnell 1917, MacArthur et al. 1962, James 1971, Whittaker et al. 1973). Hall et al. (1997:175) sought to provide standards, and they defined habitat as "the resources and conditions present in an area that produce occupancy—including survival and reproduction—by a given organism." This is the definition of habitat used in this paper. Hall et al. (1997) considered habitat quality as the ability of the environment to provide conditions appropriate for individual and population persistence. This is an intuitive and attractive operational definition of habitat quality, but much is masked by considering habitat quality to relate to both individual- and

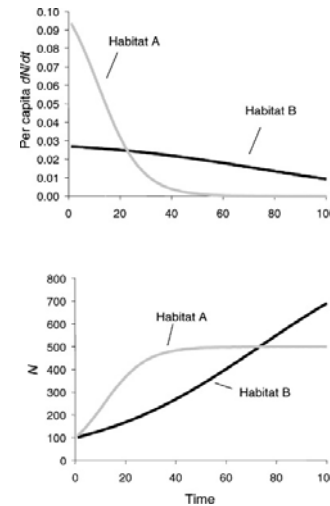


FIGURE 2. Logistic population growth curves for birds in two hypothetical habitats. Habitat A has relatively few high-quality resources and Habitat B has abundant lower-quality resources, resulting in a higher intrinsic rate of population growth in A ( $r_A = 0.12$ ,  $r_B = 0.03$ ) and a higher carrying capacity in B ( $K_A = 500$ ,  $K_B = 1000$ ). Both populations were simulated with initial population sizes of 100 and run for 100 time intervals. If habitat quality is considered purely from an individual bird's perspective, then Habitat A is the better habitat until time 23, after which point Habitat B offers the higher average per capita  $dN/dt$ . In contrast, if habitat quality is measured as the current population size, then Habitat A remains better until time 74. If habitat quality is considered the maximum sustained population size, as may be the perspective of many conservationists, then Habitat B is always better because it has the higher carrying capacity.

population-level perspectives. For example, consider two habitats: Habitat A has relatively few high-quality resources and Habitat B has abundant lower-quality resources (Fig. 2). The details of the resources are unimportant; they could be nest sites for a songbird or rodent prey for a raptor, for example. Habitat A offers the

higher intrinsic rate of population growth ( $r$ ) and Habitat B has a higher carrying capacity ( $K$ ). Which habitat is better? From an individual bird's perspective, Habitat A is better in many respects because it offers access to high quality resources that maximize a bird's chances for survival and reproduction. However, at a population level, Habitat B may be better because it supports a larger persistent local population. This trade-off in quality and quantity of resources was explored by Hobbs and Hanley (1990), and it underscores the necessity of distinguishing habitat quality from the perspective of individual animals, which seek to maximize their own fitness, from the perspective of conservationists concerned with populations (Pidgeon et al. 2006).

Organisms occupying habitats that maximize their lifetime reproductive success will contribute the most to future generations; that is, habitat is a key contributor to an individual's fitness (Newton 1989, Block and Brennan 1993, Franklin et al. 2000). Natural selection therefore favors the capacity for individuals to distinguish high and low quality habitats (Clark and Shuttler 1999). Though fitness is an individual measure, Fretwell and Lucas (1970) combined the concepts of habitat and fitness into the notion that a habitat confers fitness on its occupants. Wiens (1989b) considered this contribution to an organism's fitness the *habitat fitness potential*, which provides the theoretical basis for habitat quality (Garshelis 2000, Railsback et al. 2003). For example, Franklin et al. (2000) quantified habitat fitness potential for Northern Spotted Owls (*Strix occidentalis caurina*) as the relative contribution to the overall population of individuals occupying a given habitat. Thus, habitat quality at the level of an individual bird is defined as the per capita contribution to population growth expected from a given habitat. This conceptualization of habitat quality places evolutionary fitness in a measurable, ecological context with variation that can be quantified over space and time (Coulson et al. 2006) and provides the definition of habitat quality used throughout this paper.

Over most population densities, intraspecific competition diminishes the fitness conferred upon a habitat's occupants (Rodenhouse et al. 2003, Sillett et al. 2004). Note, however, that low population densities can suppress fitness if

mate selection is constrained (see review of Allee effects by Stephens and Sutherland [1999]), and high density can be attractive to an individual if conspecifics are useful cues for resources insensitive to density-dependent competition (see reviews by Stamps 1991, Ahlring and Faaborg 2006) or for species that enjoy marked benefits of sociality. Thus, theoreticians distinguish the quality of habitat in the absence of competition, called *fundamental habitat quality*, from the quality actually experienced by competing occupants, called *realized habitat quality*. Under an ideal free distribution (Fretwell and Lucas 1970), equal competitors select habitats to maximize their individual fitness. At equilibrium, individuals are distributed among habitats that vary in fundamental habitat quality (also called intrinsic or inherent habitat quality or zero-density suitability sensu Bernstein et al. [1991]) such that all individuals experience the same realized habitat quality (Fig. 3). Under ideal despotic distributions or mixed models, individuals are unequal competitors and preemption of resources or territories in the highest quality habitats ensures that the strongest competitors reap the greatest rewards (Parker and Sutherland 1986). Thus, at equilibrium the average fitness conferred by a habitat on its occupants—realized habitat quality—is lower in habitats with low fundamental habitat quality (Fig. 3).

The distinction between these models is important because they can yield opposing prioritization of habitats for managers. Under the ideal free model, fundamental habitat quality corresponds with density. Therefore, although all individuals receive the same reward at equilibrium, the habitats with the most birds are fundamentally higher in quality and should be prioritized for conservation. Under a despotic distribution, the equilibrium density among fundamentally rich and poor habitats depends on the relative competitive abilities of strong and weak competitors. If weak competitors are much more influenced by competition than strong competitors, the density of birds in poor habitats is likely to be higher than that in rich habitats (Bernstein et al. 1991). In this case, density will be a misleading indicator of habitat quality, and prioritizing habitats should involve measuring the performance of individual birds to assess variation in realized habitat quality.

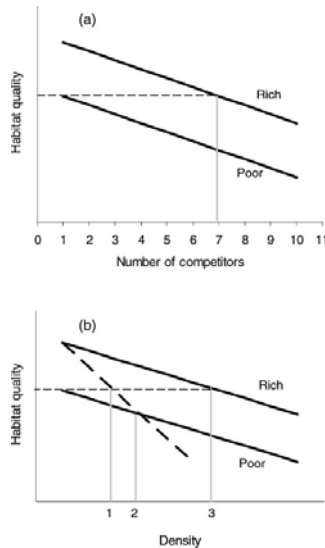


FIGURE 3. Models of (a) ideal free and (b) ideal despotic distributions (from Fretwell and Lucas 1970, Parker and Sutherland 1986, Bernstein et al. 1991). Two habitats varying in quality are modeled; each shows a linear density-dependent decline in quality. Fundamental habitat quality is the intrinsic quality of a habitat in the absence of intraspecific competition, realized habitat quality accounts for negative effects of competition. In the ideal free distribution, the first six competitors select the rich habitat to maximize realized habitat quality conferred; the seventh chooses between the partially filled rich habitat and the empty poor habitat, which offer the same realized habitat quality at densities of seven and one, respectively (depicted by horizontal dashed line). In the despotic distribution model, competitors are unequal. As density increases, weak competitors (diagonal dashed line) suffer a steeper decline in realized habitat quality than do strong competitors. At density 1 in the rich habitat, strong competitors occupy the rich habitat only, but for weak competitors, realized habitat quality in the rich habitat has diminished to the level of fundamental habitat quality in the poor habitat. At density 2, it pays weak competitors to occupy the poor habitat exclusively. Strong competitors should not use the poor habitat until they reach density 3.

In this light, the question “which habitat is best?” can be reexamined by asking, how do we measure habitat quality for the relevant management unit (populations), when habitat selection is a process operating at the individual level? To understand individual habitat quality for population management purposes, we must consider how temporal and spatial scales influence habitat choices and their demographic consequences (Wiens 1989a, Lambrechts et al. 2004). A habitat’s quality can change rapidly for a given species, and care must be taken to understand when resources are most limited and when consequences of habitat occupancy most influence a population (Sherry and Holmes 1995). Sutherland (1998) and Runge and Marra (2005) developed models to articulate the temporal (seasonal) interactions of local habitat quality, availability, and global demographics in birds. These models extended previous work describing how individual birds’ choices of habitats (based on local quality) impact populations over shorter temporal windows (Orians and Wittenberger 1991, Goss-Custard, Caldwell et al. 1995). These models all evince the delay between birds’ habitat choices and their demographic consequences, which should prompt researchers to track their birds’ fates as long as possible.

Spatially, a bird’s use of the landscape can vary dramatically, with some areas (even within its home range) nearly ignored while other receive intense use (Manley et al. 2002). Thus, fine scales of habitat selection (e.g., Johnson’s [1980] 2nd and 3rd orders) must be understood to fully uncover nuanced spatial patterns of habitat quality. Moreover, some birds may not achieve adequate fitness unless multiple habitats are juxtaposed in ways that enable them to meet all their life history requirements (Gullion 1984, 1988). Consequently, population viability may be strongly influenced by the composition of rich and poor habitat patches in a landscape (Pulliam 1988, Dunning et al. 1992, Wiens 2000), underscoring the importance of examining habitat quality over large spatial extents (Pulliam 1988, Howell et al. 2000, Fahrig 2003). Thus, ecologists should focus on the individual consequences of habitat occupancy across a landscape (i.e., indicators of habitat quality) to inform land management decisions, because these consequences ultimately manifest in population dynamics (Sutherland 1996). Indeed,

measuring habitat quality for individual wild animals is a necessary precursor for discerning effects of landscape composition on population dynamics (Pulliam 2000, Runge et al. 2006).

## MEASURING HABITAT QUALITY

### SURVEY OF THE LITERATURE

To assess how ornithologists have measured habitat quality, I reviewed papers published in the last 21 years (1984 to 2005). I chose 1984 as a start date because it was the first full publication year following the publication of van Horne’s (1983) *Density as a misleading indicator of habitat quality*; 2005 was the latest year with complete database records at writing. I searched titles, abstracts, and key words for the term habitat (or patch) adjacent to the term quality (or suitability). Searches in nonornithological journals also included the term bird. I limited my search to 27 journals, chosen based on their relevance to avian habitat ecology (listed in decreasing number of retrieved titles): *Auk*, *Journal of Avian Biology* (Ornis Scandinavica), *Journal of Wildlife Management*, *Condor*, *Journal of Animal Ecology*, *Journal of Applied Ecology*, *Ibis*, *Conservation Biology*, *Ecology*, *Journal of Field Ornithology*, *Waterbirds*, *Oikos*, *Proceedings of the Royal Society of London Series B*, *Wilson Bulletin*, *Oecologia*, *Journal of Raptor Research*, *American Midland Naturalist*, *Behavioral Ecology*, *American Naturalist*, *Science*, *Behavioral Ecology and Sociobiology*, *Nature*, *Trends in Ecology & Evolution*, *Conservation Ecology*, *Animal Conservation*, *Animal Biodiversity and Conservation*, and *Proceedings of the National Academy of Sciences USA*. I surveyed papers using the *Wildlife and Ecology Studies Worldwide database* (<http://biblioline.nisc.com/scripts/login.dll>), which has a complete index of surveyed journals since 1984 (or since first publication for newer journals). Papers were first examined to determine whether authors either claimed to have measured habitat quality empirically or drew conclusions concerning habitat quality based on the data presented. For each paper satisfying this requirement, I classified how habitat quality was measured, tallying one or more of the 12 categories of measurements listed in Table 1 and described in more detail in the following section. I summarized results by calculating the percentage of

TABLE 1. Percentage of 173 ornithological studies published in 27 journals between 1984 and 2005 that used various measures of habitat quality. Twelve different types of measurements were grouped into two basic approaches, one of which was subdivided into three general categories (demographic, distributional, and individual condition measurements). Percentages often combine to more than 100% because many studies used more than one habitat quality measurement.

Measurements of habitat quality	% of studies
Measure habitat attributes directly	37
Resources	23
Environmental constraints	6
Crude correlates	15
Measure birds to reveal habitat quality	74
Demographic measures	53
Density or abundance	26
Reproduction	37
Survival	10
Distributional measures	31
Habitat selection (spatial patterns)	19
Occupancy (temporal patterns)	7
Arrival or departure patterns	2
Behavioral or age class distribution	6
Individual condition measures	9
Morphological variables	7
Physiological variables	3

total papers that used each category of habitat quality measurement. Many studies measured habitat quality in multiple ways, with an average of  $1.6 \pm 0.1$  SE types of measurements used in each study (range: 1–6). Of 241 papers identified by the database search, 173 measured habitat quality empirically and were included in this review.

#### BASIC APPROACHES

There are two basic approaches to conceptualizing how to measure habitat quality. We can either assess habitat quality directly by measuring attributes of a habitat itself, or we can measure variables for individual birds and populations in different habitats to reveal variation in habitat quality. In measuring habitats directly, we should of course be concerned with critical resources, such as food and nest sites. Yet habitat is far more than the vegetation and resources surrounding an animal. Equally important are the ecological constraints that may limit the use of those resources, such as risk of predation, intensity of competition, and physical accessibility of resources. Indeed, habitat is defined not only by

the resources necessary for survival and reproduction, but also by the conditions that constrain their use (Morrison et al. 2006).

Relatively few studies measuring habitat attributes directly do so in an attempt to explicitly measure habitat quality. That is not to say few studies measure vegetation and resources as a means to describe habitat. To the contrary, the literature is rife with studies relating animal distribution or demography to aspects of habitat, especially vegetation (Scott et al. 2002, Morrison et al. 2006). Yet, few of these studies consider vegetation metrics to be measurements of habitat quality. Instead, they rank the quality of habitats based on the abundance, distribution, or performance of birds inhabiting them and use statistical associations with habitat measurements to identify features potentially contributing to a habitat's quality. This descriptive approach to examining wildlife-habitat relationships is of limited use (Morrison 2001), and experimental work is underutilized to test hypotheses relating habitat quality to features of the landscape humans can potentially influence, such as vegetation cover, forest stand characteristics, habitat fragmentation, and so on.

Nonetheless, the features hypothesized to govern habitat quality are feasibly quantified in some systems, allowing habitat quality to be measured directly. For example, Barnes et al. (1995) measured habitat quality for Northern Bobwhites (*Colinus virginianus*) by quantifying grass forage quality, food (insect) abundance, and availability of cover. Rodenhouse et al. (2003) evaluated habitat quality for nesting Black-throated Blue Warblers (*Dendroica caerulescens*) by surveying for nest predators, quantifying shrub density, and calculating caterpillar and spider biomass in individual birds' territories. Goss-Custard, Clarke et al. (1995) documented food availability and competition to quantify habitat quality for Oystercatchers (*Haematopus ostralegus*). These approaches assume we understand (or can work to learn) which resources and environmental conditions actually influence habitat quality for birds, and they require we devise techniques to measure these attributes accurately. In well-studied species like those cited above, researchers have worked toward this goal. However, we simply do not know enough about many bird species to follow this approach. Among the 173

papers reviewed, less than 25% quantified resources available to birds, and only 6% quantified how predation, competition, or other factors affected a habitat's quality (Table 1). Without adequate knowledge of critical resources and constraints and established protocols for how to measure them, researchers aiming to assess avian habitat quality directly may be tempted to use crude vegetation measurements (often gross vegetation type) as surrogates for habitat quality, which is unlikely to yield worthwhile results. Nonetheless, about 15% of the studies reviewed followed this approach. For many systems, it will be more efficient and meaningful to evaluate habitat quality by studying birds in different habitats, using variation in their demographics or performance to reveal variation in habitat quality.

#### MEASURING BIRDS TO REVEAL HABITAT QUALITY

Most studies take the second conceptual approach by quantifying bird abundance, distribution, or performance among different habitats to assess variation in habitat quality (Table 1). Few studies can measure all of these potential indicators of habitat quality simultaneously, and it is not always clear which measure is most appropriate. Here, I classify these bird-based indicators of habitat quality into three broad groups—demographic, distributional, and individual condition measures—and describe some strengths and limitations of each.

Some authors have also used behavioral observations as proxies for other measures of habitat quality. For example, Lyons (2005) used foraging behaviors as measures of food supply to deduce habitat quality for Prothonotary Warblers (*Protonotaria citrea*). Vickery et al. (1992) introduced the idea of measuring adult behavior to reveal likely nesting outcomes without the need to locate nests, and Brown and his colleagues (Brown 1988, Kohlmann and Risenhoover 1996) pioneered the use of the residual density of food in artificial food patches ("giving up density") to reveal costs associated with foraging, such as predation risk. These measures can certainly advance our understanding of avian habitat ecology, but because they usually reveal only a portion of a habitat's value (foraging value and in some

cases also predation risk), they are not included in this review.

**Demographic measures.** As explained earlier, habitat quality is best defined from an individual bird's perspective as the per capita rate of population increase expected from a given habitat. Thus, the roots of the concept are demographic and habitat-specific measures of density, reproduction, and survival offer some of the best measures of habitat quality (Virkkala 1990, Holmes et al. 1996, Franklin et al. 2000, Murphy 2001, Persson 2003, Knutson et al. 2006). Using demographics to measure habitat quality assumes the parameters are both measurable and attributable to habitat. Over half of the papers reviewed used at least one form of demographic parameter to assess habitat quality (Table 1). Most studies involving demographic measures of habitat quality focused on abundance or reproduction, perhaps reflecting a bias toward temperate-breeding bird species. Only 10% of the studies measured adult survival, probably because of the large and lengthy datasets required to assess it rigorously. However, survival assessments have recently become more frequent, perhaps due to the increased availability and power of survival analysis software (White and Burnham 1999, Murray and Patterson 2006). Over 23% of the studies employing demographic measures of habitat quality published in 2001 or later included measures of survival, whereas only 8% did so prior to 2001 ( $\chi^2_1 = 3.9, P = 0.05$ ).

The chief disadvantage of demographic measures of habitat quality is that they are difficult to obtain. Only 4% of the papers reviewed included simultaneous estimates of density, reproduction, and survival (for classification purposes, I considered assessments of nest survival as measures of reproduction). In each of these exemplary cases, however, a broad understanding of habitat quality was obtained. For example, Holmes et al. (1996) discovered that high shrub density was associated with high bird density, high per capita fledging success, and low mortality (or emigration) for Black-throated Blue Warblers in New Hampshire; Franklin et al. (2000) confirmed that the highest reproductive and survival rates for Northern Spotted Owls in northwestern California were in areas containing mosaics of old and young forests, whereas too much of one forest age or the other was associated with

diminished fitness potential; and Murphy (2001) learned that annual productivity of Eastern Kingbirds (*Tyrannus tyrannus*) was lower in floodplain than in creek and upland habitats in the Charlotte Valley of central New York, but estimates of survival suggested that all three habitats were population sinks whose numbers were supplemented substantially by immigration.

Quantifying multiple indicators of habitat quality is, in theory, critically important, because habitat conditions favoring density, survival, and reproduction may not be the same (Franklin et al. 2000), which could lead to misleading measures of habitat quality if only one parameter is used to rank habitats. Van Horne (1983) and Vickery, Wells et al. (1992) provided hypothetical scenarios and empirical examples in which density was high while reproduction was low. However, Bock and Jones (2004) demonstrated that density was usually roughly correlated with habitat quality for breeding birds, and that decoupling of density and reproduction was not associated with most environmental and life history attributes predicted by theory, although discrepancies emerged most frequently in human-disturbed landscapes. Future work should explore whether density and survival covary over habitats (Johnson et al. 2006). Ecologists should also continue to explore new field techniques to feasibly measure previously elusive demographic parameters. For example, tracking the survival of small migratory birds from space may be possible with the international space station (Cochran and Wikelski 2005), biomarkers may make possible the estimation of population size (Garshelis and Visser 1997) and reproduction (Hebert and Wassenaar 2005) over large areas, and stable isotopes can link habitat-specific demographics with habitat choices made by birds in previous seasons (Marra et al. 1998, Gunnarsson et al. 2005).

**Distributional measures.** The ideal free and ideal despotic distribution models provide the theoretical backdrop for how animal distribution may reveal variation in habitat quality (Fig. 3). The measures all share the assumptions that: (a) birds have (or can quickly obtain) perfect knowledge of realized habitat quality, (b) birds select habitats that maximize their individual fitness, (c) there are no dispersal or

selection costs, and (d) there are no "time lags" (birds remaining distributed according to previous rather than current habitat quality; Wiens 1989b).

Numerous measures of bird distribution can be used to indicate habitat quality based on these models. The disproportionate use of a habitat relative to its availability—called habitat selection (Jones 2001)—can indicate high-quality habitats, and the field and analytical methods to investigate habitat selection are well described (Manly et al. 2002, Morrison et al. 2006, Thomas and Taylor 2006). Of the papers reviewed, 19% employed habitat selection as a measure of habitat quality. For example, Hunt (1996) used patterns of habitat selection to evaluate habitat quality for American Redstarts (*Setophaga ruticilla*) breeding along a successional gradient in New England; Hall and Mannan (1999) examined habitat selection to determine what constituted high-quality habitat for Elegant Trogons (*Trogon elegans*) in southeastern Arizona, which highlighted the importance of sycamore trees (*Platanus wrightii*); and Hirzel et al. (2004) used habitat selection to assess habitat quality for the first Bearded Vultures (*Gypaetus barbatus*) reintroduced into the European Alps to inform future releases.

The principal weakness in using distribution to reveal habitat quality is that numerous scenarios can lead to animals selecting poor and avoiding rich habitats (Rapport 1991, Railsback et al. 2003), including incomplete information (Shochat et al. 2002, Stamps et al. 2005), ecological traps (Battin 2004), time lags and site fidelity (Davis and Stamps 2004), strong despotic distributions (Parker and Sutherland 1986), a lack of high-quality habitat (Halpern et al. 2005), and others (Bernstein et al. 1991, Block and Brennan 1993, Kristan 2003). Thus, researchers should first establish how well a given system adheres to patterns of ideal habitat selection before using animal distribution to reveal variation in habitat quality (Clark and Shuter 1999, Pulliam 2000, Morris 2003, Zimmerman et al. 2003). This is, of course, easier said than done, since the very incentive for interpreting bird distribution as a measure of habitat quality is because measuring fitness itself is often impractical. Nonetheless, density-dependent habitat selection models (e.g., ideal free and ideal despotic

models) can be examined with techniques that do not require quantifying fitness. For example, 'isodar analyses' (Morris 1987, 1988, 2003) can reveal deviations from ideal free distributions (Shochat et al. 2002) and only require that densities are measured repeatedly in two or more habitats. Examination of the 'habitat-matching rule' (Fagan 1987) can also reveal deviations from ideal distributions, but this method relies on measuring resource abundance in a variety of habitats (Johnson and Sherry 2001, Shochat et al. 2002), which is often difficult. Ornithologists should work to identify other practical techniques to evaluate how closely wild birds follow ideal distributions that do not require rigorous estimates of fitness.

Habitat selection models predict that, relative to low-quality habitats, high-quality habitats should be occupied for longer periods within a season and more consistently over years. Consequently, some investigators have used timing, duration, and frequency of habitat occupancy as measures of habitat quality (reviewed by Sergio and Newton 2003). For example, Ferrer and Donazar (1996) found that habitat occupancy was related to both resource availability and reproduction for Imperial Eagles (*Aquila heliaca*) in Spain. This approach, which was followed by only 7% of the papers I reviewed, has the advantage that simple occupancy is usually far easier to quantify than intensive demographics, and it could be very useful for populations in heterogeneous landscapes and for which not all habitats are occupied every year. However, using temporal patterns of occupancy as a measure of habitat quality usually requires multiple seasons of data and can be clouded by changes in population size or landscape features. Moreover, site fidelity and social constraints or other forms of "time lags" (Wiens 1989b) can cause poor-quality habitats to remain occupied even when better habitats become available, decoupling the link between habitat occupancy and quality (Pulliam 2000). In addition, for birds whose home ranges encompass numerous patches of potentially very different habitats, it may be difficult to ascribe quality based on occupancy without understanding precisely which patches within the home range are most critical. Note that this discussion relates to temporal patterns in occupancy; examining spatial patterns of occupancy (e.g., "occupancy modeling" with

presence/absence analyses) is a form of use-availability habitat selection analysis (MacKenzie 2006), which is discussed above.

If birds distribute themselves among habitats with respect to their quality, habitats used for portions of the annual cycle should be inhabited in sequence from best to worst and abandoned from worst to best. Thus, arrival and departure dates in different habitats can be used as measures of habitat quality, especially for migratory birds (Alatalo et al. 1986, Marra 2000, Marra and Holmes 2001, Gunnarsson et al. 2006). For example, Lanyon and Thompson (1986) found that arrival patterns correlated with reproduction and habitat quality in Painted Buntings (*Passerina ciris*), and Smith and Moore (2005) confirmed that early-arriving American Redstarts chose the best habitats available and achieved higher reproductive output than later arrivals. This approach has the advantage of being easily measured for some systems (e.g., newly arriving and singing males), and arrival date can potentially reveal information relevant to the previous phase of the annual cycle (Gill et al. 2001, Norris 2005). However, this measurement may not be feasible for nonmigratory species showing strong site tenacity or little movement or for species with cryptic arrival and departure schedules. Perhaps as a result of these challenges, this technique has been relatively little used as a measure of habitat quality (2% of papers reviewed; Table 1). In addition, as with all distributional measures, the accuracy of this measurement as a metric of habitat quality is diminished if birds do not have adequate information on available habitats (Stamps et al. 2005), and recent work suggests birds may use each other as indicators of where to settle (Muller et al. 1997, Ahlering and Faaborg 2006), causing the initial settling period to be highly dynamic and not necessarily strongly associated with spatial variation in habitat quality.

Despotic distribution models predict that dominant individuals should settle disproportionately in the highest quality habitats. Therefore, the ratio of behavioral classes among habitats (e.g., adult vs. young, male vs. female) could reveal variation in their quality (Railsback et al. 2003). For example, Rohwer (2004) used age ratios to show that despotic territorial behavior forced yearling male Hermit (*Den-*

*droica occidentalis*) and Townsend's (*D. townsendi*) Warblers into marginal high-elevation habitats for their first potential breeding season, and Marra (2000) found that ratios of dominant to subordinate age and sex classes of wintering American Redstarts varied markedly between high-quality (mangrove) and low-quality (scrub forest) habitats in Jamaica. Approximately 6% of the papers reviewed used this measurement of habitat quality. This approach can be convenient for field studies, but it requires that dominant and subordinate individuals be easily distinguished (e.g., by age-specific plumage or body size) and relies on a well-established despotic distribution. Moreover, precisely when age ratios are determined is important, because postbreeding age ratios are often used as an index of reproduction, with the opposite prediction—the best (most productive) habitats should have a low ratio of adults:young (Flanders-Wanner et al. 2004, Peery et al. 2007).

**Individual condition measures.** Many of the measurements of habitat quality reviewed so far require measuring populations of birds, often over extended breeding or nonbreeding periods. These approaches can be problematic for species that are difficult to observe or capture and for birds using habitats only briefly, such as migratory species. As an alternative, some researchers have used measures of individual birds' physical condition as indicators of habitat quality (9% of papers reviewed).

We can distinguish variables that rely on external, visible, and measurable features, which I call morphological condition measures, from variables that rely on analysis of sampled tissues (especially blood), called physiological condition measures. Regardless, all measures of body condition share two requirements to be useful as indicators of habitat quality. First, variation in condition must be a consequence (rather than a cause) of differential habitat use. That is, variation in habitat attributes such as food supply and predation risk must lead to variation in physical condition. This may often be at least partially true, but in some systems it is also likely that preexisting differences in condition lead birds to use different habitats. For example, lean individuals may choose food-rich but risky habitats while fat individuals may choose safer but food-poor habitats

(Moore and Aborn 2000). In this case, local food supply and body fat would be inversely related, and good body condition would be a poor indicator of food-rich habitats. Second, using measures of body condition as indicators of habitat quality requires that differences in condition ultimately manifest in differential fitness. This has been confirmed in only a few species (Béty et al. 2003, Johnson et al. 2006) and merits further study. Statistically significant variation in body condition among habitats does not guarantee variation in reproduction or survival.

It is also important for researchers to match the temporal scale over which measures of body condition change to the temporal scale over which habitat quality is sought to be judged. For example, analysis of induced feather growth (ptilochronology) has been used to reflect nutritional aspects of habitat quality for birds during the time it takes to regrow a feather with a sufficient number of growth bars for measurement (several weeks to months; Grubb 1989, Grubb and Yosef 1994). In contrast, body mass can change seasonally in response to fluctuations in environmental conditions such as habitat quality (Rintamäki et al. 2003), and plasma metabolites change hourly, reflecting the feeding and fasting behavior of birds occupying habitats over very short temporal "windows" (Jenni-Eiermann and Jenni 1994). This variation in measures of body condition over time both enhances and detracts from their capacity as indicators of habitat quality. On one hand, dynamic measures of body condition are potentially much more sensitive to variation in habitat quality than are more static measures, such as demographics, and they may enable biologists to quantify habitat quality for birds occupying habitats only briefly. On the other hand, these dynamic measures may be too subject to temporal fluctuation to reveal lasting variation in habitat quality. For example, fat stores in wintering songbirds may reveal more about recent weather patterns than about the quality of winter-occupied habitats (Rogers et al. 1994). Measures of body condition that change more slowly may be useful to rank habitats occupied for long periods, but for mobile species they may not reflect local habitat quality. For example, the condition of a migratory songbird at a stopover site may be more dependent on

the habitats it has occupied in the previous months than on its current habitat conditions (Bearhop et al. 2004). Researchers must seek to understand which periods of the season are most critical, and optimize their sampling of body condition accordingly.

Many different body condition measures have been considered indicators of habitat quality. Common morphological measures include changes in body mass (Pöysä et al. 2000), body size (often based on multiple morphometrics), mass corrected for body size (Latta and Faaborg 2002), fat stores (Strong and Sherry 2000, Brown et al. 2002), ptilochronology (Grubb and Yosef 1994, Carlson 1998), various measures of pigmentation (especially the prominence of ultraviolet wavelengths; Siefferman and Hill 2005), and fluctuating asymmetry (Lens et al. 1999), the latter based on the notion that high-quality habitats enable symmetrical morphological development. Physiological measures have been less commonly used, but endocrinological indicators of stress (e.g., concentrations of corticosterone in blood) have increasingly been used to assess habitat quality (Marra and Holberton 1998, Lanctot et al. 2003). Recently, workers have suggested that concentrations of blood plasma metabolites, especially triglycerides and  $\beta$ -hydroxy-butyrate (Jenni-Eiermann and Jenni 1994, Williams et al. 1999, Seaman et al. 2006), can indicate short-term patterns of foraging and fasting and thus provide a measure of habitat quality. With all of these measures, researchers should first confirm they indicate habitat quality as hypothesized by comparing measures in habitats known from independent work to be high and low in quality (Guglielmo et al. 2005).

#### RECOMMENDATIONS

Animal distribution is dependent upon the fitness conferred by selected habitats (Fretwell and Lucas 1970), which provides the theoretical underpinnings for conceptualizing and measuring habitat quality for birds (Block and Brennan 1993, Franklin et al. 2000). When we know what resources and ecological constraints govern fitness and can measure them, measuring habitat quality directly is advisable, but it is often impractical in field settings. Researchers and managers should resist the temptation to

use vegetation type as a crude surrogate for habitat quality.

When using habitat-specific measures of the abundance, performance, or condition of birds to reveal habitat quality, ecologists should emphasize demographics whenever feasible. This approach is appropriate because the root of habitat quality as a concept lies in demography (Block and Brennan 1993, Hall et al. 1997, Knutson et al. 2006), and demographic measurements suffer from few limitations except their difficulty to obtain. In addition, for managers to effect change for wild birds, they must work to identify on-the-ground variables that influence avian demography. However, reproduction, survival, and abundance may not all be positively correlated, which can lead to misleading indicators of habitat quality. In the past, researchers have too often measured only one parameter at a time (especially abundance or reproduction). To enable ecologists and managers to more successfully measure multiple demographic indicators of habitat quality, new methods and technologies should be developed to feasibly quantify previously elusive parameters for wild birds.

When quantifying variables related to the distribution of birds as measures of habitat quality (e.g., habitat selection or habitat occupancy), investigators should first investigate how closely their study species follow ideal distributions, because a variety of ecological factors can lead birds to select poor and avoid rich habitats, violating critical assumptions of all distributional measures. Resolving whether a given bird population more closely follows a free or despotic distribution will also determine whether density is likely to be correlated with fundamental habitat quality. To improve the reliability of distributional measures of habitat quality, ecologists need more approaches for assessing model assumptions that do not require measuring fitness.

Lastly, measures of body condition can provide convenient measures of habitat quality, and they offer exciting new methods to assess habitat quality, but the link between body condition and habitat-specific fitness has been confirmed in relatively few systems. Much work is needed to evaluate whether measures of body condition are as useful as distribution and demographics for indicating variation in avian habitat quality.

## ACKNOWLEDGMENTS

Thanks to Bill Kristan, Allan Strong, and the Humboldt State University advanced habitat ecology classes for stimulating discussion of this topic. Barrett Garrison, Dirk Van Vuren, and two anonymous reviewers provided helpful suggestions on an earlier version of this manuscript.

## LITERATURE CITED

- AHLERING, M. A., AND J. FAABORG. 2006. Avian habitat management meets conspecific attraction: if you build it, will they come? *Auk* 123:301-312.
- ALATALO, R. V., A. L. LUNDBERG, AND C. GYNN. 1986. Female Pied Flycatchers choose territory quality and not male characteristics. *Nature* 323:152-153.
- BARNES, T. G., A. L. MADISON, J. D. SOLE, AND M. J. LACKI. 1995. An assessment of habitat quality for Northern Bobwhite in tall fescue-dominated fields. *Wildlife Society Bulletin* 23:231-237.
- BATTIN, J. 2004. When good animals love bad habitats: ecological traps and the conservation of animal populations. *Conservation Biology* 18:1482-1491.
- BEARHOP, S., G. M. HILTON, S. C. VOTIER, AND S. WALDRON. 2004. Stable isotope ratios indicate that body condition in migrating passerines is influenced by winter habitat. *Proceedings of the Royal Society of London Series B* 271:215-218.
- BERNSTEIN, C. M., J. R. KREBS, AND A. KACELNIK. 1991. Distribution of birds amongst habitats: theory and relevance to conservation, p. 317-345. *In* C. M. Perrins, J. D. Lebreton, and G. J. M. Hirons [EDS.], *Bird population studies: relevance to conservation and management*. Oxford University Press, Oxford, UK.
- BÉTY, J., G. GAUTHIER, AND J. F. GIROUX. 2003. Body condition, migration, and timing of reproduction in snow geese: a test of the condition-dependent model of optimal clutch size. *American Naturalist* 162:110-121.
- BLOCK, W. M., AND L. A. BRENNAN. 1993. The habitat concept in ornithology: theory and applications. *Current Ornithology* 11:35-91.
- BOCK, C. E., AND Z. F. JONES. 2004. Avian habitat evaluation: should counting birds count? *Frontiers in Ecology and the Environment* 2:403-410.
- BROWN, D. R., C. M. STRONG, AND P. C. STOUFFER. 2002. Demographic effects of habitat selection by Hermit Thrushes wintering in a pine plantation landscape. *Journal of Wildlife Management* 66:407-416.
- BROWN, J. L. 1969. Territorial behavior and population regulation in birds. *Wilson Bulletin* 81:293-329.
- BROWN, J. S. 1988. Patch use as an indicator of habitat preference, predation risk, and competition. *Behavioral Ecology and Sociobiology* 22:37-47.
- CARLSON, A. 1998. Territory quality and feather growth in the White-backed Woodpecker *Dendrocopos leucotos*. *Journal of Avian Biology* 29:205-207.
- CLARK, R. G., AND D. SHUTLER. 1999. Avian habitat selection: pattern from process in nest-site use by ducks? *Ecology* 80:272-287.
- COCHRAN, W. W., AND M. WIKELSKI. 2005. Individual migratory tactics of New World *Catharus* thrushes, p. 274-289. *In* R. Greenberg and P. P. Marra [EDS.], *Birds of two worlds*. Johns Hopkins Press, Baltimore, MD.
- CODY, M. L. [ED.]. 1985. *Habitat selection in birds*. Academic Press, Orlando, FL.
- COULSON, T., T. G. BENTON, P. LUNDBERG, S. R. X. DALL, B. E. KENDALL, AND J.-M. GAILLARD. 2006. Estimating individual contributions to population growth: evolutionary fitness in ecological time. *Proceedings of the Royal Society of London Series B* 273:547-555.
- DAVIS, J. M., AND J. A. STAMPS. 2004. The effect of natal experience on habitat preferences. *Trends in Ecology & Evolution* 19:411-416.
- DUNNING, J. B., B. J. DANIELSON, AND P. R. PULLIAM. 1992. Ecological processes that affect populations in complex landscapes. *Oikos* 65:169-175.
- FAGAN, R. 1987. A generalized habitat matching rule. *Evolutionary Ecology* 1:5-10.
- FAHRIG, L. 2003. Effects of habitat fragmentation on biodiversity. *Annual Review of Ecology, Evolution and Systematics* 34:487-515.
- FERRER, M., AND J. A. DONÁZAR. 1996. Density-dependent fecundity by habitat heterogeneity in an increasing population of Spanish Imperial Eagles. *Ecology* 77:69-74.
- FLANDERS-WANNER, B. L., G. C. WHITE, AND L. L. MCDANIEL. 2004. Validity of prairie grouse harvest age ratios as production indices. *Journal of Wildlife Management* 68:1088-1094.
- FRANKLIN, A. B., D. R. ANDERSON, R. J. GUTIERREZ, AND K. P. BURNHAM. 2000. Climate, habitat quality, and fitness in Northern Spotted Owl populations in northwestern California. *Ecological Monographs* 70:539-590.
- FRETWELL, S. D., AND H. L. LUCAS JR. 1970. On territorial behavior and other factors influencing habitat distribution in birds. I. Theoretical development. *Acta Biotheoretica* 19:16-36.
- GARSHELIS, D. L. 2000. Delusions in habitat evaluation: measuring use, selection, and importance, p. 111-164. *In* L. Boitani and T. K. Fuller [EDS.], *Research techniques in animal ecology: controversies and consequences*. Columbia University Press, New York.
- GARSHELIS, D. L., AND L. G. VISSER. 1997. Enumerating megapopulations of wild bears with an ingested biomarker. *Journal of Wildlife Management* 61:466-480.
- GILL, J. A., K. NORRIS, AND P. M. POTTS. 2001. The buffer effect and large-scale population regulation in migratory birds. *Science* 292:436-438.
- GOSS-CUSTARD, J. D., R. W. G. CALDOW, R. T. CLARKE, AND A. D. WEST. 1995. Deriving population parameters from individual variations in foraging behaviour. II. Model tests and population parameters. *Journal of Animal Ecology* 64:277-289.
- GOSS-CUSTARD, J. D., R. T. CLARKE, S. E. A. LE V. DIT DURELL, R. W. G. CALDOW, AND B. J. ENS. 1995. Population consequences of winter habitat loss in a migratory shorebird. II. Model predictions. *Journal of Applied Ecology* 32:337-351.
- GRINNELL, J. 1917. The niche-relationships of the California Thrasher. *Auk* 34:427-433.
- GRUBB, T. C., JR. 1989. Ptilochronology: feather growth bars as indicators of nutritional status. *Auk* 106:314-320.
- GRUBB, T. C., JR., AND R. YOSEF. 1994. Habitat-specific nutritional condition in Loggerhead Shrikes (*Lanius ludovicianus*): evidence from ptilochronology. *Auk* 111:756-759.
- GUGLIELMO, C. G., D. J. CERASALE, AND C. ELDERMIRE. 2005. A field validation of plasma metabolite profiling to assess refueling performance of migratory birds. *Physiological and Biochemical Zoology* 78:116-125.
- GULLION, G. W. 1984. *Managing northern forests for wildlife*. The Ruffed Grouse Society, Coraopolis, PA.
- GULLION, G. W. 1988. Aspen management for Ruffed Grouse, p. 9-12. *In* T. W. Hoekstra [ED.], *Integrating forest management for wildlife and fish*. USDA Forest Service North Central Forest Experiment Station General Technical Report NC-122.
- GUNNARSSON, T. G., J. A. GILL, P. W. ATKINSON, G. GELINAUD, P. M. POTTS, R. E. CROGER, G. A. GUDMUNDSSON, G. F. APPLETON, AND W. J. SUTHERLAND. 2006. Population-scale drivers of individual arrival times in migratory birds. *Journal of Animal Ecology* 75:1119-1127.
- GUNNARSSON, T. G., J. A. GILL, J. NEWTON, P. M. POTTS, AND W. J. SUTHERLAND. 2005. Seasonal matching of habitat quality and fitness in a migratory bird. *Proceedings of the Royal Society of London Series B* 272:2319-2323.
- HALL, L. S., P. R. KRAUSMAN, AND M. L. MORRISON. 1997. The habitat concept and a plea for standard terminology. *Wildlife Society Bulletin* 25:171-182.
- HALL, L. S., AND R. W. MANNAN. 1999. Multiscaled habitat selection by Elegant Trogons in southeastern Arizona. *Journal of Wildlife Management* 63:451-461.
- HALPERN, B. S., S. D. GAINES, AND R. R. WARNER. 2005. Habitat size, recruitment, and longevity as factors limiting population size in stage-structured species. *American Naturalist* 165:82-94.
- HEBERT, C. E., AND L. I. WASSenaar. 2005. Stable isotopes provide evidence for poor Northern Pintail production on the Canadian prairies. *Journal of Wildlife Management* 69:101-109.
- HIRZEL, A. H., B. POSSE, P.-A. OGGIER, Y. CRETENAND, C. GLENZ, AND R. ARLETTAZ. 2004. Ecological requirements of reintroduced species and the implications for release policy: the case of the Bearded Vulture. *Journal of Applied Ecology* 41:1103-1116.
- HOBBS, N. T., AND T. A. HANLEY. 1990. Habitat evaluation: do use/availability data reflect carrying capacity? *Journal of Wildlife Management* 54:515-522.
- HOLMES, R. T., P. P. MARRA, AND T. W. SHERRY. 1996. Habitat-specific demography of breeding Black-throated Blue Warblers (*Dendroica caerulescens*): implications for population dynamics. *Journal of Animal Ecology* 65:183-195.
- HOWELL, C. A., S. C. LATTA, T. M. DONOVAN, P. A. PORNELUZI, G. R. PARKS, AND J. FAABORG. 2000. Landscape effects mediate breeding bird abundance in Midwestern forests. *Landscape Ecology* 15:547-562.
- HUNT, P. D. 1996. Habitat selection by American Redstarts along a successional gradient in northern hardwoods forest: evaluation of habitat quality. *Auk* 113:875-888.
- JAMES, F. C. 1971. Ordinations of habitat relationships among breeding birds. *Wilson Bulletin* 83:215-236.
- JENNI-EIERMANN, S., AND L. JENNI. 1994. Plasma metabolite levels predict individual body-mass changes in a small long-distance migrant, the Garden Warbler. *Auk* 111:888-899.
- JOHNSON, M. D. 1980. The comparison of usage and availability measurements for evaluating resource preference. *Ecology* 61:65-71.
- JOHNSON, M. D., AND T. W. SHERRY. 2001. Effects of food availability on the distribution of migratory warblers among habitats in Jamaica, West Indies. *Journal of Animal Ecology* 70:546-560.
- JOHNSON, M. D., T. W. SHERRY, R. T. HOLMES, AND P. P. MARRA. 2006. Measuring habitat quality for a migratory songbird wintering in natural and agricultural areas. *Conservation Biology* 20:1433-1444.
- JONES, J. 2001. Habitat selection studies in avian ecology: a critical review. *Auk* 118:557-562.
- KNUTSON, M. G., L. A. POWELL, R. K. HINES, M. A. FRIBERG, AND G. J. NIEMI. 2006. An assessment of bird habitat quality using population growth rates. *Condor* 108:301-314.
- KOHLMANN, S. G., AND K. L. RISENHOVER. 1996. Using artificial food patches to evaluate habitat quality for granivorous birds: an application of foraging theory. *Condor* 98:854-857.
- KRISTAN, W. B., III. 2003. The role of habitat selection behavior in population dynamics: source-sink systems and ecological traps. *Oikos* 103:457-468.
- LAMBRECHTS, M. M., S. CARO, A. CHARMANTIER, N. GROSS, M.-J. GALAN, P. PERRET, M. CARTAN-SON, P. C. DIAS, J. BLONDEL, AND D. W. THOMAS. 2004. Habitat quality as a predictor of spatial variation in Blue Tit reproductive performance: a multi-plot analysis in a heterogeneous landscape. *Oecologia* 141:555-561.
- LANCOT, R. B., S. A. HATCH, V. A. GILL, AND M. EENS. 2003. Are corticosterone levels a good indicator of food availability and reproductive performance in a kittiwake colony? *Hormones and Behavior* 43:489-502.

- LANYON, S. M., AND C. F. THOMPSON. 1986. Site fidelity and habitat quality as determinants of settlement pattern in male Painted Buntings. *Condor* 88:206–210.
- LATTA, S. C., AND J. FAABORG. 2002. Demographic and population responses of Cape May Warblers wintering in multiple habitats. *Ecology* 83:2502–2515.
- LENS, L., S. VAN DONGEN, C. M. WILDER, T. M. BROOKS, AND E. MATTHYSEN. 1999. Fluctuating asymmetry increases with habitat disturbance in seven bird species of a fragmented Afrotropical forest. *Proceedings of the Royal Society of London Series B* 266:1241–1246.
- LYONS, J. E. 2005. Habitat specific foraging of Prothonotary Warblers: deducing habitat quality. *Condor* 107:41–49.
- MACARTHUR, R. H., J. W. MACARTHUR, AND J. PEER. 1962. On bird species diversity II: prediction of bird census from habitat measurements. *American Naturalist* 96:167–174.
- MACKENZIE, D. I. 2006. Modeling the probability of resource use: the effect of, and dealing with, detecting a species imperfectly. *Journal of Wildlife Management* 70:367–374.
- MANLY, B. F. J., L. L. McDONALD, D. L. THOMAS, T. L. McDONALD, AND W. P. ERICKSON. 2002. Resource selection by animals. 2nd ed. Kluwer Academic Publishers, Dordrecht, The Netherlands.
- MARRA, P. P. 2000. The role of behavioral dominance in structuring patterns of habitat occupancy in a migrant bird during the nonbreeding season. *Behavioral Ecology* 11:299–308.
- MARRA, P. P., K. A. HOBSON, AND R. T. HOLMES. 1998. Linking winter and summer events in a migratory bird by using stable-carbon isotopes. *Science* 282:1884–1886.
- MARRA, P. P., AND R. L. HOLBERTON. 1998. Corticosterone levels as indicators of habitat quality: effects of habitat segregation in a migratory bird during the non-breeding season. *Oecologia* 116:284–292.
- MARRA, P. P., AND R. T. HOLMES. 2001. Consequences of dominance-mediated habitat segregation in American Redstarts during the non-breeding season. *Auk* 118:92–104.
- MOORE, F. R., AND D. A. ABORN. 2000. Mechanisms of *en route* habitat selection: how do migrants make habitat decisions during stopover? *Studies in Avian Biology* 20:34–42.
- MORRIS, D. W. 1987. Tests of density-dependent habitat selection in a patchy environment. *Ecological Monographs* 57:269–281.
- MORRIS, D. W. 1988. Habitat-dependent population regulation and community structure. *Evolutionary Ecology* 2:253–269.
- MORRIS, D. W. 2003. How can we apply theories of habitat selection to wildlife conservation and management? *Wildlife Research* 30:303–319.
- MORRISON, M. L. 2001. A proposed research emphasis to overcome the limits of wildlife-habitat relationship studies. *Journal of Wildlife Management* 65:613–623.
- MORRISON, M. L., AND L. S. HALL. 2002. Standard terminology: toward a common language to advance ecological understanding and application, p. 43–52. *In* J. M. Scott, P. J. Heglund, M. L. Morrison, M. L. J. B. Haulfer, M. G. Raphael, W. A. Wall, and F. B. Samson [EDS.], *Predicting species occurrences*. Island Press, Washington, DC.
- MORRISON, M. L., B. G. MARCOT, AND R. W. MANNAN. 2006. Wildlife-habitat relationships: concepts and applications. 3rd ed. Island Press, Washington, DC.
- MULLER, K. L., J. A. STAMPS, V. V. KRISHNAN, AND N. H. WILLITS. 1997. The effects of conspecific attraction and habitat quality on habitat selection in territorial birds (*Troglodytes aedon*). *American Naturalist* 150:650–661.
- MURPHY, M. T. 2001. Source-sink dynamics of a declining Eastern Kingbird population and the value of sink habitats. *Conservation Biology* 15:737–748.
- MURRAY, D. L., AND B. R. PATTERSON. 2006. Wildlife survival estimation: recent advances and future directions. *Journal of Wildlife Management* 70:1499–1503.
- NEWTON, I. 1989. Lifetime reproduction in birds. Academic Press, London.
- NEWTON, I. 1998. Population limitation in birds. Academic Press, San Diego, CA.
- NORRIS, R. D. 2005. Carry-over effects and habitat quality in migratory populations. *Oikos* 109:179–186.
- ORIANI, G. H., AND J. F. WITTENBERGER. 1991. Spatial and temporal scales in habitat selection. *American Naturalist* 137:S29–S49.
- PARKER, G. A., AND W. J. SUTHERLAND. 1986. Ideal free distributions when individuals differ in competitive ability: phenotype-limited ideal free models. *Animal Behaviour* 34:1222–1242.
- PEERY, M. Z., B. H. BECKER, AND S. R. BEISSINGER. 2007. Age ratios as estimators of productivity: testing assumptions on a threatened seabird, the Marbled Murrelet (*Brachyramphus marmoratus*). *Auk* 124:224–240.
- PERSSON, M. 2003. Habitat quality, breeding success and density in Tawny Owl *Strix aluco*. *Ornis Svecica* 13:137–143.
- PIDGION, A. M., V. C. RADELOFF, AND N. A. MATTHEWS. 2006. Contrasting measures of fitness to classify habitat quality for the Black-throated Sparrow (*Amphispiza bilineata*). *Biological Conservation* 132:199–210.
- POYSA, H., J. ELMBERG, K. SJÖBERG, P. NUMMI, H. POYSAL, AND K. SJÖBERG. 2000. Nesting Mallards (*Anas platyrhynchos*) forecast brood-stage food limitation when selecting habitat: experimental evidence. *Oecologia* 122:582–586.
- PULLIAM, H. R. 1988. Sources, sinks and population regulation. *American Naturalist* 132:652–661.
- PULLIAM, H. R. 2000. On the relationship between niche and distribution. *Ecology Letters* 3:349–361.
- RAILSBACK, S. F., H. B. STAUFFER, AND B. C. HARVEY. 2003. What can habitat preference

- models tell us? Tests using a virtual trout population. *Ecology* 13:1580–1594.
- RAPPORT, D. J. 1991. Myths in the foundation of economics and ecology. *Biological Journal of the Linnean Society* 44:185–202.
- RINTAMÄKI, P. T., J. R. STONE, A. LUNDBERG, AND F. MOORE. 2003. Seasonal and diurnal body-mass fluctuations for two nonhoarding species of *Parus* in Sweden modeled using path analysis. *Auk* 120:658–668.
- RODENHOUSE, N. L., T. S. SILLETT, P. J. DORAN, AND R. T. HOLMES. 2003. Multiple density-dependence mechanisms regulate a migratory bird population during the breeding season. *Proceedings of the Royal Society of London Series B* 270:2105–2110.
- ROGERS, C. M., V. NOLAN JR., AND E. D. KETTERSON. 1994. Winter fattening in the Dark-eyed Junco: plasticity and possible interaction with migration trade-offs. *Oecologia* 97:526–532.
- ROHWER, S. 2004. Using age ratios to infer survival and despotic breeding dispersal in hybridizing warblers. *Ecology* 85:423–431.
- RUNGE, M. C., AND P. P. MARRA. 2005. Modeling seasonal interactions in the population dynamics of migratory birds, p. 375–389. *In* R. Greenberg and P. P. Marra [EDS.], *Birds of two worlds*. Johns Hopkins Press, Baltimore, MD.
- RUNGE, J. P., M. C. RUNGE, AND J. D. NICHOLS. 2006. The role of local populations within a landscape context: defining and classifying sources and sinks. *American Naturalist* 167:925–938.
- SCHAMBERGER, M., A. H. FARMER, AND T. J. TERRELL. 1982. Habitat suitability index (HSI) models: introduction. U.S. Fish and Wildlife Service Special Report FWS-OBS-82-10.
- SCOTT, J. M., P. J. HEGLUND, M. L. MORRISON, J. B. HAUFER, M. G. RAPHAEL, W. A. WALL, AND F. B. SAMSON [EDS.]. 2002. Predicting species occurrences. Island Press, Washington, DC.
- SEAMAN, D. A., A. C. G. GUGLIEMO, R. W. ELNER, AND T. D. WILLIAMS. 2006. Landscape-scale physiology: site differences in refueling rates indicated by plasma metabolite analysis in free-living migratory sandpipers. *Auk* 123:563–574.
- SERGIO, F., AND I. NEWTON. 2003. Occupancy as a measure of habitat quality. *Journal of Animal Ecology* 72:857–865.
- SHERRY, T. W., AND R. T. HOLMES. 1995. Summer versus winter limitation of populations: issues and evidence, p. 85–120. *In* Y. M. Martin and D. Finch [EDS.], *Ecology and management of Neotropical migratory birds*. Oxford University Press, Oxford, UK.
- SHOCHAT, E., Z. ABRAMSKY, B. PINSHOW, AND M. E. A. WHITEHOUSE. 2002. Density-dependent habitat selection in migratory passerines during stopover: what causes the deviation from IFD? *Evolutionary Ecology* 16:469–488.
- SIEFFERMAN, L., AND G. E. HILL. 2005. UV-blue structural coloration and competition for nest-boxes in male Eastern Bluebirds. *Animal Behaviour* 69:67–72.
- SILLETT, T. S., N. L. RODENHOUSE, AND R. T. HOLMES. 2004. Experimentally reducing neighbor density affects reproduction and behavior of a migratory songbird. *Ecology* 85:2467–2477.
- SMITH, R., AND F. R. MOORE. 2005. Arrival timing and seasonal reproductive performance in a long-distance migratory landbird. *Behavioral Ecology and Sociobiology* 57:231–239.
- STAMPS, J. A. 1991. The effect of conspecifics on habitat selection in territorial species. *Behavioral Ecology and Sociobiology* 28:29–36.
- STAMPS, J. A., V. V. KRISHNAN, AND M. L. REID. 2005. Search costs and habitat selection by dispersers. *Ecology* 86:510–518.
- STEPHENS, P. A., AND W. J. SUTHERLAND. 1999. Consequences of the Allee effect for behaviour, ecology and conservation. *Trends in Ecology & Evolution* 14:401–405.
- STRONG, A. M., AND T. W. SHERRY. 2000. Habitat-specific effects of food abundance on the condition of Ovenbirds wintering in Jamaica. *Journal of Animal Ecology* 69:883–895.
- SUTHERLAND, W. J. 1996. From individual behaviour to population ecology. Oxford University Press, Oxford, UK.
- SUTHERLAND, W. J. 1998. The effect of local change in habitat quality on populations of migratory species. *Journal of Applied Ecology* 35:418–421.
- SUTHERLAND, W. J., AND G. A. PARKER. 1985. Distribution of unequal competitors, p. 255–273. *In* R. M. Sibly and R. H. Smith [EDS.], *Behavioural ecology: ecological consequences of adaptive behaviour*. Blackwell Scientific, Oxford, UK.
- THOMAS, D. L., AND E. J. TAYLOR. 2006. Study designs and tests for comparing use and availability II. *Journal of Wildlife Management* 70:324–336.
- VAN HORNE, B. 1983. Density as a misleading indicator of habitat quality. *Journal of Wildlife Management* 47:893–901.
- VICKERY, P. D., M. L. HUNTER JR., AND J. V. WELLS. 1992. Is density an indicator of breeding success? *Auk* 109:706–710.
- VICKERY, P. D., J. V. WELLS, M. L. HUNTER JR., AND J. V. WEISS. 1992. Use of a new reproductive index to evaluate relationship between habitat quality and breeding success. *Auk* 109:697–705.
- VIKKALA, R. 1990. Ecology of the Siberian Tit *Parus cinereus* in relation to habitat quality: effects of forest management. *Ornis Scandinavica* 21:139–146.
- WHITE, G. C., AND K. P. BURNHAM. 1999. Program MARK: survival estimation from populations of marked animals. *Bird Study* 46:S120–S138.
- WHITTAKER, R. H., S. A. LEVIN, AND R. B. ROOT. 1973. Niche, habitat, and ecotope. *American Naturalist* 107:321–338.
- WIENS, J. A. 1989a. Spatial scaling in ecology. *Functional Ecology* 3:385–397.
- WIENS, J. A. 1989b. The ecology of bird communities. Vol. I. Foundations and patterns. Cambridge University Press, Cambridge, UK.



- WIENS, J. A. 2000. Ecological heterogeneity: an ontogeny of concepts and approaches, p. 9–31. *In* M. J. Hutchings, E. A. John, and A. J. A. Stewart [EDS.], *The ecological consequences of environmental heterogeneity*. Blackwell Science, Oxford, UK.
- WILLIAMS, T. D., C. G. GUGLIELMO, O. EGELER, AND C. J. MARTYNIUK. 1999. Plasma lipid metabolites provide information on mass change over several days in captive Western Sandpipers. *Journal of Avian Biology* 33:1–9.
- ZIMMERMAN, G. S., W. S. LAHAYE, AND R. J. GUTIÉRREZ. 2003. Empirical support for a despotic distribution in a California Spotted Owl population. *Behavioral Ecology* 14:433–437.

## Habitat Restoration—Do We Know What We're Doing?

James R. Miller<sup>1,2,4</sup> and Richard J. Hobbs<sup>3</sup>

### Abstract

The term "habitat restoration" appears frequently in conservation and landscape management documents but is often poorly articulated. There is a need to move to a clearer and more systematic approach to habitat restoration that considers appropriate goals linked to target species or suites of species, as well as the ecological, financial, and social constraints on what is possible. Recommendations for particular courses of action need to be prioritized so that restoration activities can achieve the best result possible within these constraints. There is unlikely to be

a generic set of recommendations that is applicable everywhere because actions need to be matched to the particulars of site and situation. However, there is a generic set of questions that can be asked, which can help guide the process of deciding which restoration actions are most important and contribute most to the reestablishment of desirable habitat characteristics within a given project area.

**Key words:** financial constraints, goal setting, limiting resources, prioritization, social constraints, target species.

### Introduction

"Habitat restoration" is a frequently used term that appears in a variety of arenas. The term covers the general topic of restoring ecosystems for the specific purpose of providing habitat—either for the individual species or for the entire suite of species likely to be found in an area. It is also used more broadly to represent the restoration of native plant communities (e.g., Gilbert & Anderson 1998). Increasing the amount of habitat present in a given area is often a primary motivation for undertaking restoration, particularly where extensive ecosystem fragmentation and modification have taken place (e.g., Hobbs & Lambeck 2002; Lambeck & Hobbs 2002). However, in many cases, little attention is given to deciding what restoring "habitat" actually means: what constitutes habitat and what are its essential components? There appears to be a continuum of expectations around this issue, with some projects aiming at, for instance, restoring "forest," and others focusing on specific structural elements of the forest, on important forest processes, or on factors that benefit target species.

Interestingly, the idea of "habitat restoration" is less prevalent within the broader thinking of restoration ecologists; for instance, the Society for Ecological Restoration

(SER) Primer (SER International Science & Policy Working Group 2004) only mentions the word habitat three times. In the introduction to a special section on "Wildlife Habitat and Restoration," Morrison (2001a) noted that the application of principles from wildlife ecology to restoration has lagged behind advances related to plant ecology.

In this article, we suggest that, to date, there has been relatively little attempt to clarify exactly what is meant by the term "habitat restoration." How is habitat defined and described, how do we set goals in relation to habitat restoration, and what is possible in the face of biophysical, financial, and social constraints? We first discuss the habitat concept and ways that the definition of habitat affects the restoration process. We then describe a general process of habitat restoration that focuses on goal setting, linking goals to target species, and prioritizing actions based on the goals that have been set and the constraints that are in place.

### The Habitat Concept

Two distinct usages of the term habitat have emerged in recent decades, one that is organism specific and another that is land based (Corsi et al. 2000; Miller 2000; Morrison 2001b). In the first instance, habitat is typically defined as an area containing the particular combination of resources and environmental conditions that are required by individuals of a given species or group of species to carry out life processes (Hall et al. 1997; Morrison et al. 1998; SER International Science & Policy Working Group 2004). Although the focus here has often been restricted to

vegetation, this need not be the case. Abiotic resources as well as other biotic factors, such as competitors and predators, are also likely to play important roles in determining suitable conditions for a given species in a given location (Mitchell 2005), although these factors are perhaps more difficult to quantify. This definition of habitat has a long history (Hall et al. 1997; Corsi et al. 2000), but in recent decades, a second meaning has become more prevalent, whereby the term has been used to refer to areas of similar vegetation or land cover, as in the notion of "habitat types" (Daubenmire 1968).

The concept of habitat types provides a convenient framework for mapping large areas on the basis of features that are easily discerned in aerial photos or satellite images. Maps of this sort, the stock-in-trade of many projects based on geographic information systems (GIS), tend to focus our attention on the arrangement and size of patches. This may be useful in advancing our understanding of habitat selection at broad scales (Johnson 1980; Hutto 1985) or in identifying potential restoration sites in a landscape. However, attempts to define landscape-scale restoration priorities based on habitat types or vegetation cover, pattern metrics (e.g., fragmentation indices), and vague objectives (e.g., biodiversity conservation) pose real obstacles to effective habitat restoration.

Broad-scale typological characterizations of habitat are of limited use in guiding the particulars of restoration projects. This is because the resources or conditions that directly contribute to the well-being of a species may not exhibit a strong correlation with surrogate variables, such as patch area or dominant vegetation type (Mitchell & Powell 2003). For example, a categorical land-cover map for a landscape in the Midwestern United States may depict an extensive patch of grassland habitat but will not provide detailed enough information to tell which grassland-

obligate bird species would find suitable conditions there. These species vary in their response to vegetation structure (Fig. 1), yet the vegetation within a given polygon or patch on such a map is treated as though it were uniform. It will also be impossible to tell if prairie-obligate butterflies are likely to occur in such an area because the assumption of uniformity would not reveal the presence, amount, or distribution of host plants or nectar sources on which these species depend.

Thus, when the goal is to improve conditions for one or more species, restoration must be guided by an organism-based consideration of habitat. A land-based conceptualization will not suffice to identify the requisite biotic and abiotic factors that need to be restored.

### Goals for Habitat Restoration

Given the above considerations, how might we go about setting appropriate goals for habitat restoration? Habitat restoration projects vary greatly in scale, ranging from small urban restorations aiming to restore patches of native plant species through landscape-scale projects that aim to counteract the impacts of habitat fragmentation by increasing the amount and connectivity of habitat over broad areas (e.g., Dilworth et al. 2000; McDonald 2004). In all cases, however, the level of success achieved will depend on a careful consideration and clear statement of the project's goals.

Goals are derived from a complex mix of ecological, social, historical, and philosophical viewpoints (Hobbs 2004, 2007) but, in many cases, are not formulated in such a way as to guide effective habitat restoration. Often, the stated goals relate to restoring a system back to some former structure and/or composition based either on historical information or on nearby reference ecosystems

<sup>1</sup> Department of Natural Resource Ecology and Management, 339 Science II, Iowa State University, Ames, IA 50011-3221, U.S.A.

<sup>2</sup> Department of Landscape Architecture, 339 Science II, Iowa State University, Ames, IA 50011-3221, U.S.A.

<sup>3</sup> School of Environmental Science, Murdoch University, Murdoch, Western Australia 6150, Australia

<sup>4</sup> Address correspondence to James R. Miller, email jrmliller@iastate.edu

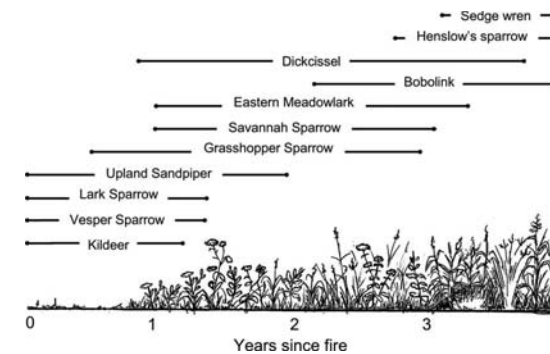


Figure 1. Use of prairie habitats in the central United States by grassland-obligate bird species, based on Poole and Gill (2002).

(e.g., Egan & Howell 2001). Similarly, for broader landscape-scale projects, the goal of restoration is often simply the provision of more of what is already there. Too often, there is not a rigorous assessment of the degree to which "what is already there" (or what we assume was there historically) meets the needs of the species that the restoration is intended to help.

Figure 2 summarizes the key set of considerations that need to be taken into account when embarking on a habitat restoration project. These include determining the target species of the restoration, deciding on the key habitat elements to be restored, and assessing the landscape context. In this article, we focus mainly on the first two of these issues but do not discount the importance of landscape-scale concerns.

Identifying a focal or target species or group of species must necessarily be the first step in habitat restoration; their requirements will thereafter serve to guide the process. This choice will maximize conservation benefits if it is made in the context of regional goals (Dale et al. 2000; Scott et al. 2001; Groves et al. 2002). To do otherwise will likely result in a piecemeal approach that greatly diminishes prospects for population viability of the target species over the long term.

Once an appropriate focal species or group has been identified, the next objective is to identify the biotic and abiotic resources that are required by the species to persist. In some instances, identifying resources must be preceded by deciding on the life stage or process that the

habitat restoration is intended to accommodate. Some species may complete their life cycles in one contiguous area, whereas others may breed in one habitat, forage in another, and overwinter in yet another. In either case, it will be necessary to provide enough resources (including space) to support a viable population, whether this is accomplished solely in the area to be restored or in combination with existing habitat (Smallwood 2001).

Ensuring availability of resources through time may also be an issue. The nature of the resource will define the temporal scale that must be considered. Standing dead trees, for example, may serve as suitable nesting and feeding sites for snag-dependent species over several years, providing the trees are of an appropriate size and decay status, and occur at the proper density (George & Zack 2001). In other cases, the duration of availability for a given resource is more fine grained. For instance, the honey possum (*Tarsipes rostratus*), a small nocturnal marsupial in southwestern Australia, requires a constant supply of nectar throughout the year (Wooller et al. 1999). Given the species' small size and lack of long-distance movement capability, meeting this requirement depends on the presence of a suite of plant species that differ in their phenologies so that something is flowering in the area year round.

Resource availability will depend on landscape connectivity for species requiring multiple habitats, and this becomes a key issue, especially in areas dominated by human activities (Beier & Noss 1998; Debinski & Holt 2000; Hobbs 2002). If the distance between habitats is

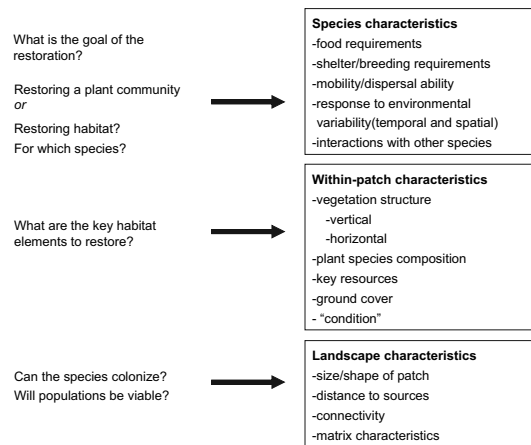


Figure 2. Key considerations when setting goals for habitat restoration projects.

short relative to the dispersal capability of the target species, it may only be necessary to provide structural features that are similar to those in the remnants. Additional resources may also be required if the dispersal capability of the focal species is limited relative to the distance that must be covered.

**Constraints on Restoration**

The other aspect of setting goals relates to ensuring that they are realistic given the constraints within which the restoration has to take place. Here, we consider these constraints in three categories—ecological, economic, and social (Fig. 3). Ecological constraints set limits on what is possible based on the biophysical realities of the site and its surroundings. Within the broader context of what is physically possible, both financial and social constraints set limits on the scope of work that can be done. Furthermore, available funding will be limited by social constraints and public attitudes in this regard will be influenced by the perceived "payoff" for a given expenditure on restoration.

**Ecological Constraints**

It is a truism that the distribution of species and ecosystems across the globe is closely linked to an array of climatic, geological, and soil parameters at all scales (e.g., Holdridge 1967; Box 1996; Bailey 1998). Hence, most species and ecosystems occur within relatively well-defined climatic envelopes and are tied either directly or indirectly to particular soil conditions. Restoration generally aims to work within the same set of environmental constraints; for instance, at a crude level, one would not try to restore a rainforest in a desert.

**Ecological Constraints**

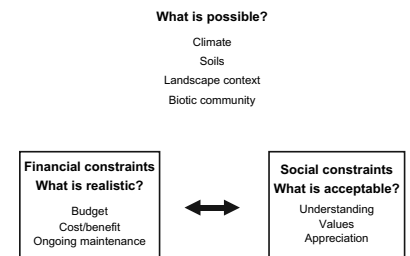


Figure 3. Three types of constraints on habitat restoration. Ecological factors ultimately constrain what is possible, then what is actually achieved becomes a function of financial and social factors, both of which will tend to influence one another.

However, the fact that restoration is generally taking place following some form of environmental degradation means that the original set of environmental conditions has been modified in some way. If the level of degradation is severe, an area may no longer be suitable for species that once occurred there. For example, soils in some parts of Los Angeles have experienced such high levels of heavy metal deposition from automobile exhaust that restoring native plants there is no longer an option (Woodward 2005).

Suitability may also be affected by changes in land use and land cover. As mentioned above, habitat types may be useful in characterizing the surrounding landscape and thus identifying upper constraints on what is actually possible in restoration locally. Such constraints will be a function of the types and juxtaposition of habitats and land use, and the particular sensitivities of the species in question. Landscapes with a higher percentage of natural land cover are in general more likely to support native species that are of conservation concern compared with those in which intensive human land uses predominate (Noss & Cooperrider 1994). Having said this, restorations in areas with relatively little native land cover remaining may still have value for conservation (Miller & Hobbs 2002; Miller 2005, 2006).

It is important to note that the relationship between the amount of suitable habitat present in a landscape and the abundance of a given species may not be linear. Numerous species have been shown to exhibit thresholds in their response to overall habitat area, below which they tend to disappear regardless of the quality of the habitat that remains (Andr n 1994; Bissonette et al. 1997; Mladenoff et al. 1999). Unless such thresholds have been previously detected, however, it will likely be difficult to identify them a priori (Miller et al. 2004). In lieu of empirical data for a given situation, Andr n (1994) has shown that many species tend to be absent in landscapes where habitat loss exceeds 70% and this figure could be used as a general guideline.

Finally, another factor to be considered is the increasing rate of change in environmental parameters caused by human-induced shifts in climate and land use, and the growing number of invasive species present in many ecosystems. Harris et al. (2006) have recently reviewed the likely implications of global climate change for ecological restoration, and several recent accounts highlight the need to consider invasive species as an increasingly integral component of many ecosystems (e.g., Low 1999; Hobbs et al. 2006). These changed conditions present many conundrums for conservation and restoration, exemplified by the current debate in the western United States over the relative risks and values of saltcedar (*Tamarix* spp.), an invasive plant species that disrupts hydrologic and riparian processes on one hand, but provides critical habitat for a threatened species on the other (Anderson 1998; Burrows 1998; Zavaleta 2000; Cohn 2005). In this and similar cases, if restoration requires the removal of the invasive vegetation, mechanisms must also be in place for simultaneously

providing alternative resources for species that have come to depend on it.

An across-the-board emphasis on removing exotic vegetation may be counter productive, however, as instances have been documented where the net effects of these species on a given system are neutral or even beneficial. For instance, Thacker (2004) reports that 14 of 32 native butterfly species in Davis, California rely completely on exotic plants as hosts. In fact, such plants provided alternative resources for these species when their ancestral home, a nearby marsh, was converted to human uses. Indirect effects of exotic vegetation must also be considered. Again using the Davis example, one butterfly species exclusively uses the only species of native mistletoe in the area, yet the abundance of this key host plant stems from the fact that many non-native trees planted in the town are particularly susceptible to being parasitized by it.

#### Financial Constraints

It could be argued that there are many goals that become attainable with enough money, but in the majority of cases, finances are limiting and it is essential to determine the greatest gain per unit of investment. Although ecological constraints ultimately set limits on what is possible, financial constraints set limits on what is realistic. Here, we suggest that it is important to consider not only what can be achieved with different levels of funding but also what the shape of the relationship between costs and gains in habitat quality are under different scenarios (Fig. 4). This clarifies what may or may not be realistic in a given

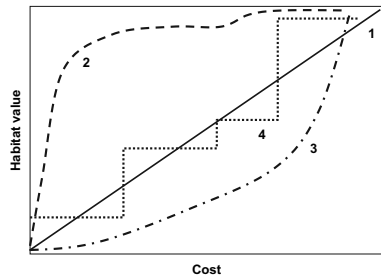


Figure 4. Value of restored habitat versus the financial input to the restoration project for a number of different scenarios. (1) Habitat value increases linearly with the amount spent on the restoration; (2) restoring a high proportion of the desired habitat value is achieved relatively cheaply, but achieving further small additions to habitat value becomes increasingly expensive; (3) relatively little value is restored until considerable expenditure is invested; (4) habitat value increases in a stepwise way in response to the need for expenditure to overcome particular biotic or abiotic thresholds.

situation and, indeed, may offer opportunities to extend what is realistic by more careful assessment of what needs to be done and when.

An unstated assumption might be that the value of restored habitat increases linearly with the amount spent on the restoration (Fig. 4, line 1). However, it seems more likely that this relationship can assume a number of alternative forms. In some cases, restoring a high proportion of the desired habitat value may be achieved relatively cheaply, but at some point even small improvements become disproportionately expensive (Fig. 4, line 2). An example of this would be where most of the critical resources are provided by a few key plant species, which are relatively easy to reestablish. However, additional species may be more difficult to restore, and hence, any additional habitat value they provide may cost substantially more. Alternatively, relatively few benefits accrue from restoration efforts until considerable expenditure is invested, for instance, in earthworks or soil remediation activities (Fig. 4, line 3; e.g., Zentner et al. 2003). Finally, habitat value may increase in a stepwise fashion in response to the need for expenditure to overcome successive biotic or abiotic thresholds (Fig. 4, line 4; Hobbs & Norton 1996; Whisenant 1999, 2002; Hobbs & Harris 2001). This might be the most realistic scenario in many cases, where a series of relatively discrete management actions is required to achieve the reestablishment of different habitat elements (e.g., fencing out domestic stock, soil conditioning, replanting key species).

Again referring to the earlier example from the Midwestern United States, creating suitable vegetation structure for grassland bird species may be relatively inexpensive, whereas restoring the plant compositions of native prairies that some butterfly species require could easily exceed \$4000/ha (US dollars; Snyder et al., unpublished data). Grasslands will also require frequent and ongoing management to maintain suitable habitat (Packard & Mutel 1997). Recognizing which of these scenarios applies to a given restoration project is a key step in deciding the types of activities that are required and the level of investment necessary to achieve desired outcomes.

#### Social Constraints

Whereas ecological constraints define what is possible and financial constraints determine what is realistic, social constraints will determine whether a given habitat restoration project is acceptable. Clearly, social and financial constraints are inter-related. Funding levels may depend on public acceptance of a project, whereas the degree to which the public embraces the restoration is likely to be a function of the ratio between costs and perceived benefits.

Efforts to restore habitat may be seriously hampered by an unanticipated public backlash (Gobster 2000; Van Driesche & Van Driesche 2002). Negative reactions to well-intentioned projects may stem from the failure of

environmental scientists to reconcile their own assessment of what actions are necessary with public perceptions and values. As Hull and Robertson (2000) noted, value judgments are inherent in restoration prescriptions, however, strong the underlying science may be, and the "best" course of action is always negotiable. What appears to an ecologist as habitat with the requisite structural and compositional heterogeneity to accommodate a suite of native species may strike a private landowner as messy, weedy, or neglected (Nassauer 1995, 1997). Conversely, an area thick with invasive trees and shrubs of relatively little habitat value may be much appreciated by some urban dwellers for its "natural" or "aesthetic" qualities. In such cases, successful habitat restoration must be predicated on communication of project goals and underlying rationale, as well as open dialogue to gauge public understanding and acceptance.

The importance of public acceptance of habitat restoration increases with the intensity of human settlement in the surrounding landscape. In landscapes dominated by human activity, local support for restoration projects can translate into social buffers (Van Driesche & Van Driesche 2002), which can greatly enhance habitat quality and increase effective habitat area. For example, a community that understands the objectives and merit of a project may be more willing to help reduce deleterious edge effects that often result from human activities, or participate in ongoing stewardship once the project has been completed. Fortunately, ecologists are beginning to recognize the key role that social values play in determining the outcomes of restoration (Davis & Slobodkin 2004; Hobbs et al. 2004). Social scientists and design professionals have much to offer in developing frameworks for involving the public in goal setting and enhancing the prospects for acceptance and support of restoration projects.

#### Setting Priorities

Once a restoration goal is agreed upon, how can it be best achieved? The above set of considerations implies that a clear prioritization of activities is required, both in terms of what is possible ecologically, most efficient financially, and socially acceptable. However, this appears to be largely missing from recent attempts to identify key activities in habitat restoration, or more generally in conservation management of altered landscapes (e.g., Recher 1993; Fischer et al. 2006). As one example, Marzluff and Ewing (2001) posed a set of key considerations in habitat restoration aimed at avian conservation in urbanizing landscapes. These included a mixture of within-patch and landscape concerns, as well as socioeconomic factors, and ranged from relatively straightforward prescriptions such as increasing foliage height diversity within fragments to suggestions relating to very complex regulatory and educational programs.

We applaud efforts to provide guidance by constructing such lists, which can be helpful in pointing out the array of factors, which need to be considered. Nevertheless, they can also be quite confusing and lacking utility to managers dealing with on-ground decision-making. To-do lists may ultimately be counter productive if there is not an attempt to prioritize actions or differentiate activities that fall within the sphere of influence of managers from those that are more appropriately addressed by policymakers or at different organizational levels. For instance, it may be relatively easy for local managers to institute a habitat restoration program within particular fragments, but it would be unrealistic to expect them to develop a whole new educational paradigm. Unrealistic expectations of what is possible may lead to disenchantment among practitioners or the general public and make further restoration actions less likely.

Prioritization is thus a key element in developing effective habitat restoration programs, spawning a number of questions that need to be asked, as follows:

- (1) What is the range of potential management options available?
- (2) Which options are essential, which are desirable, and which are unnecessary?
- (3) What is it most important to do first?
- (4) Are there some things, which need to be done, without which it is not worth doing any of the others? This is particularly relevant when considering whether biotic or abiotic thresholds have been crossed, which require active intervention.
- (5) Will some recommendations cost a lot more than others?
- (6) Are some actions likely to be seen in a negative light by neighboring landowners, thus requiring additional communication in advance?
- (7) What are the consequences of partial fulfillment of the recommendations (either the individual recommendations or the full set)?
- (8) If partial fulfillment of recommendations will not actually achieve the goals set for the restoration project, is there any point in embarking on it in the first place?

The answers to these questions are likely to be highly context specific and there may be no generalizable list of recommendations possible beyond the broad set provided, for instance, by Recher (1993) and Fischer et al. (2006). However, we suggest that trying to answer this set of preliminary questions as rigorously as possible will provide a useful framework for assessing what needs to be done and how best to use available resources. This may be more useful than attempting to produce a generic "laundry list" of important things to do.

The process of habitat restoration can be viewed as an attempt to move a given area from a degraded state of relatively low habitat quality toward a target of improved condition (Fig. 5). Assessment of the current condition

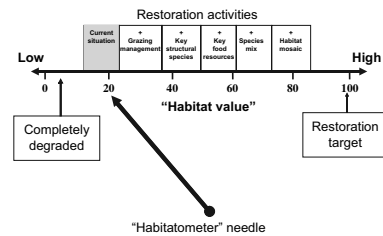


Figure 5. Habitat restoration entails assessing the current status and moving the "habitatmeter" needle progressively toward higher habitat quality. This involves identifying the types of restoration/management actions required and the order in which these need to be carried out, in the light of the ecological and financial constraints in place. Hypothetical examples of possible restoration activities are given here.

relative to the target is followed by consideration of which management options are likely to increase habitat quality. The question of how habitat quality is measured is, of course, a key concern. As indicated earlier, this usually has to be related to the requirements of the particular species of concern, although indices such as habitat complexity scores (Catling & Burt 1995) could be used where it has been established that these provide meaningful insights into an area's suitability for a particular set of species.

Clearly, we will not always have a good understanding of the precise relationship between the particular management actions and the degree of increase in habitat quality. However, thinking about things in this way at least provides a logical method for sorting out what might be useful to do. In addition, cost factors may render some actions unrealistic or unachievable under current conditions. In the case where essential actions are unachievable, it is probably best not to embark on the restoration effort at present, recognizing that circumstances may change and technological or other advances may render the action more achievable in the future.

### Considerations and Caveats

Changing climatic conditions and biotic communities pose complex challenges to efforts aimed at restoring habitat. Increasing evidence indicates that some species are almost certainly not in equilibrium with the current climate (e.g., Davis 1986; Campbell & McAndrews 1993; Swetnam 1993; Johnstone & Chapin 2003). Although it would seem that local conditions must have been suitable for the establishment of a species if it currently occurs there, it does not necessarily follow that conditions remain suitable, especially for very long-lived species. For example,

adult persistence of a given tree species in an area is not necessarily a reliable indicator of ongoing potential to include them in a restoration.

Further, when identifying specific habitat features to restore, one must be mindful of the fact that some faunal species may currently occupy suboptimal habitat. Animal species may be excluded from their preferred habitats by a range of factors such as competition from other species (native or non-native), predation by introduced predators, or simple lack of preferred habitat. For example, numerous species that were once common in the highly productive grasslands of North America were displaced by conversion to agriculture uses and now tend to occur on expansive, but relatively unproductive lands in the semi-arid west and southwest (Huston 2005). Conversely, human-influenced shifts in biotic communities often result in novel combinations of species or elevated numbers of predators or competitors. Such biotic mixing may, in turn, constrain some species in their use of particular habitats. For example, in Australia, the Eastern Bristlebird (*Dasyornis brachypterus*) was once thought of as a forest specialist, but following predator removal programs in some areas is now thought of as a generalist species (D. Lindenmeyer, The Australian National University, personal communication, 2005). Therefore, caution is warranted when inferring habitat requirements or quality from current population densities (Van Horne 1983; Bock & Jones 2004).

Given the dynamic nature of habitats, it will also be necessary to provide for population movement as resources diminish locally, as successional dynamics come into play, or in the event of disturbance. In this same vein, unless the target species is translocated to the restored habitat, a key consideration will be the landscape context of the site and how that might influence passive dispersal (Scott et al. 2001). The wide range of factors that can potentially affect colonization of a restored habitat and the persistence of the target species underscores that one of the key objectives in the planning process is ensuring that a well-designed monitoring program can be implemented once the actual restoration is complete. To be truly effective, such a program must focus on the most direct measure of the status of the target species population dynamics (Block et al. 2001).

### Conclusions

In the title of this article, we asked the question "Do we know what we are doing?" in relation to habitat restoration. We suggest that the answer in many situations is "Not really." What can we do to improve matters? The caveats discussed in the previous section indicate that there are never simple answers to questions surrounding habitat restoration. Further, we maintain that there is unlikely to be a generic set of recommendations, which is applicable everywhere, but rather that actions need to be

matched to the particulars of site and situation. Having said this, however, we feel that there is a general process that can help to identify which restoration actions are most important and have the greatest potential to contribute to the return of desirable habitat conditions within a given project area. The process we have proposed involves setting appropriate goals, linking these to target species, and taking into account the ecological, financial, and social constraints that are in place. Our approach focuses on setting priorities for action based on a systematic assessment of what is best to do where and in what order. If this type of approach is adopted, we argue that we will be in a much better position to "know what we are doing."

The need for effective habitat restoration is growing, but we must move beyond simply drawing lines on maps and calling the spaces "restored habitat"—we need to give much greater consideration to how we actually fill in these spaces to achieve the goals that are set. Our article represents an attempt to provide a means to do this, and we welcome further discussion and development of these ideas in the spirit of achieving increased restoration capability in the future.

### Implications for Practice

- The first step in habitat restoration is identifying the target species that the effort is intended to benefit.
- Once the target species is identified, habitat restoration focuses on the conditions, including key resources, necessary for the species to persist.
- Setting realistic restoration goals must be predicated on consideration of ecological, financial, and social constraints that are in place.
- There is unlikely to be a generic set of restoration actions that is applicable everywhere.

### Acknowledgment

We would like to thank Peter Cale and three anonymous reviewers for efforts to help improve this article.

### LITERATURE CITED

- Anderson, B. 1998. The case for salt cedar. *Restoration & Management Notes* 16:130–134.
- Andrén, A. 1994. Effects of habitat fragmentation on birds and mammals in landscapes with different proportions of suitable habitat: a review. *Oikos* 71:355–366.
- Bailey, R. G. 1998. *Ecoregions: the ecosystem geography of the oceans and continents*. Springer-Verlag, New York.
- Beier, P., and R. F. Noss. 1998. Do habitat corridors provide connectivity? *Conservation Biology* 12:1241–1252.
- Bissonette, J. A., D. J. Harrison, C. D. Hargis, and T. G. Chapin. 1997. The influence of spatial scale and scale-sensitive properties on habitat selection by American marten. Pages 368–385 in J. A. Bissonette, editor. *Wildlife and landscape ecology: effects of pattern and scale*. Springer-Verlag, New York.

- Block, W. M., A. B. Franklin, J. P. Ward, J. L. Ganey, and G. C. White. 2001. Design and implementation of monitoring studies to evaluate the success of ecological restoration on wildlife. *Restoration Ecology* 9:293–303.
- Bock, C. E., and Z. F. Jones. 2004. Avian habitat evaluation: should counting birds count? *Frontiers in Ecology and the Environment* 2:403–410.
- Box, E. O. 1996. Plant functional types and climate at the global scale. *Journal of Vegetation Science* 7:309–320.
- Burrows, C. 1998. The case for wholesale removal. *Restoration & Management Notes* 16:135–139.
- Campbell, I. D., and J. H. McAndrews. 1993. Forest disequilibrium caused by rapid Little Ice Age cooling. *Nature* 366:336–338.
- Catling, P. C., and R. J. Burt. 1995. Studies of the ground-dwelling mammals of eucalypt forests in south-eastern New South Wales: the effect of environmental variables on distribution and abundance. *Wildlife Research* 22:669–685.
- Cohn, J. P. 2005. Tiff over tamarisk: can a nuisance be nice, too? *BioScience* 55:648–656.
- Corsi, F., J. de Leeuw, and A. Skidmore. 2000. Modeling species distribution with GIS. Pages 389–424 in L. Boitani and T. K. Fuller, editors. *Research techniques in animal ecology: controversies and consequences*. Columbia University Press, New York.
- Dale, V. H., S. Brown, R. A. Haeuber, N. T. Hobbs, N. Huntly, R. J. Naiman, W. E. Riebsame, M. G. Turner, and T. J. Valone. 2000. Ecological principles and guidelines for managing the use of land. *Ecological Applications* 10:639–670.
- Daubenmire, R. 1968. *Plant communities*. Harper & Row, New York.
- Davis, M. B. 1986. Climatic instability, time lags and community disequilibrium. Pages 269–284 in J. Diamond and T. J. Case, editors. *Community ecology*. Harper & Row, New York.
- Davis, M. A., and I. B. Stobodkin. 2004. The science and values of restoration ecology. *Restoration Ecology* 12:1–3.
- Debinski, D. M., and R. D. Holt. 2000. A survey and overview of habitat fragmentation experiments. *Conservation Biology* 14:342–355.
- Dilworth, R., T. Gowdie, and T. Rowley. 2000. Living landscapes: the future landscapes of the Western Australian wheatbelt? *Ecological Management and Restoration* 1:165–174.
- Egan, D., and E. A. Howell, editors. 2001. *The historical ecology handbook: a restorationist's guide to reference ecosystems*. Island Press, Washington, D.C.
- Fischer, J., D. B. Lindenmayer, and A. D. Manning. 2006. Biodiversity, ecosystem function, and resilience: ten guiding principles for commodity production landscapes. *Frontiers in Ecology and Environment* 4:80–86.
- George, T. J., and S. Zack. 2001. Spatial and temporal considerations in restoring habitat for wildlife. *Restoration Ecology* 9:272–279.
- Gilbert, O. L., and P. Anderson. 1998. *Habitat creation and repair*. Oxford University Press, Oxford, United Kingdom.
- Gobster, P. H. 2000. Restoring nature: human actions, interactions, and reactions. Pages 1–20 in P. H. Gobster and R. B. Hull, editors. *Restoring nature*. Island Press, Washington, D.C.
- Groves, C. R., D. B. Jensen, L. L. Valutis, K. H. Redford, M. L. Shaffer, J. M. Scott, J. V. Baumgartner, J. V. Higgins, M. W. Beck, and M. G. Anderson. 2002. Planning for biodiversity conservation: putting conservation science into practice. *Bioscience* 52:499–512.
- Hall, L. S., P. R. Krausman, and M. L. Morrison. 1997. The habitat concept and a plea for standard terminology. *Wildlife Society Bulletin* 25:173–182.
- Harris, J. A., R. J. Hobbs, E. Higgs, and J. Aronson. 2006. Ecological restoration and global climate change. *Restoration Ecology* 14:170–176.
- Hobbs, R. J. 2002. *Habitat networks and biological conservation*. Pages 150–170 in K. J. Gutzwiller, editor. *Applying landscape ecology in biological conservation*. Springer-Verlag, New York.
- Hobbs, R. J. 2004. Restoration ecology: the challenge of social values and expectations. *Frontiers in Ecology and the Environment* 2:43–44.

- Hobbs, R. J. 2007. Setting effective and realistic restoration goals: key directions for research. *Restoration Ecology* **15**:354–357.
- Hobbs, R. J., S. Arico, J. Aronson, J. S. Baron, P. Bridgewater, V. A. Cramer, et al. 2006. Novel ecosystems: theoretical and management aspects of the new ecological world order. *Global Ecology and Biogeography* **15**:1–7.
- Hobbs, R. J., M. A. Davis, L. B. Slobodkin, R. T. Lackey, W. Halvorson, and W. Throop. 2004. Restoration ecology: the challenge of social values and expectations. *Frontiers in Ecology and the Environment* **2**:43–48.
- Hobbs, R. J., and J. A. Harris. 2001. Restoration ecology: repairing the earth's ecosystems in the new millennium. *Restoration Ecology* **9**:239–246.
- Hobbs, R. J., and R. J. Lambeck. 2002. Landscape management and restoration: new models for integrating science and action. Pages 412–430 in J. Liu and W. W. Taylor, editors. *Integrating landscape ecology into natural resource management*. Cambridge University Press, Cambridge, United Kingdom.
- Hobbs, R. J., and D. A. Norton. 1996. Towards a conceptual framework for restoration ecology. *Restoration Ecology* **4**:93–110.
- Holdridge, L. R. 1967. Life zone ecology (revised edition). Tropical Science Centre, San Jose, Costa Rica.
- Hull, R. B., and D. P. Robertson. 2000. The language of nature matters: we need a more public ecology. Pages 97–118 in P. H. Gobster and R. B. Hull, editors. *Restoring nature*. Island Press, Washington, D.C.
- Huston, M. A. 2005. The three phases of land-use change: implications for biodiversity. *Ecological Applications* **15**:1864–1878.
- Hutto, R. L. 1985. Habitat selection by nonbreeding, migratory land birds. Pages 455–476 in M. L. Cody, editor. *Habitat selection in birds*. Academic Press, Inc., San Diego, California.
- Johnson, D. H. 1980. The comparison of usage and availability measurements for evaluating resource preference. *Ecology* **61**:65–71.
- Johnstone, J. F., and F. S. Chapin. 2003. Non-equilibrium succession dynamics indicate continued northern migration of lodgepole pine. *Global Change Biology* **9**:1401–1409.
- Lambeck, R. J., and R. J. Hobbs. 2002. Landscape and regional planning for conservation: issues and practicalities. Pages 360–380 in K. Gutzwiller, editor. *Concepts and applications of landscape ecology in biological conservation*. Springer Verlag, New York.
- Low, T. 1999. *Feral future*. Viking, Ringwood, Victoria, Australia.
- Marzluff, J. M., and K. Ewing. 2001. Restoration of fragmented landscapes for the conservation of birds: a general framework and specific recommendations for urbanizing landscapes. *Restoration Ecology* **9**:280–292.
- McDonald, T. 2004. The Wilderness Society's WildCountry program. *Ecological Management and Restoration* **5**:87–97.
- Miller, C. J. 2000. Vegetation and habitat are not synonyms. *Ecological Management and Restoration* **1**:102–104.
- Miller, J. R. 2005. Biodiversity conservation and the extinction of experience. *Trends in Ecology & Evolution* **20**:430–434.
- Miller, J. R. 2006. Restoration, reconciliation, and reconnecting with nature. *Biological Conservation* **127**:356–361.
- Miller, J. R., and R. J. Hobbs. 2002. Conservation where people live and work. *Conservation Biology* **16**:330–337.
- Miller, J. R., M. G. Turner, E. A. H. Smithwick, L. C. Dent, and E. H. Stanley. 2004. Spatial extrapolation: the science of predicting ecological patterns and processes. *Bioscience* **54**:310–320.
- Mitchell, M. S., and R. A. Powell. 2003. Linking fitness landscapes with the behavior and distribution of animals. Pages 93–124 in J. A. Bissonette and I. Storch, editors. *Landscape ecology and resource management. Linking theory with practice*. Island Press, Washington, D.C.
- Mitchell, S. C. 2005. How useful is the concept of habitat?—a critique. *Oikos* **110**:634–638.
- Mladenoff, D. J., T. A. Sickley, and A. P. Wydeven. 1999. Predicting gray wolf landscape recolonization: logistic regression models vs. new field data. *Ecological Applications* **9**:37–44.
- Morrison, M. L. 2001a. Introduction: concepts of wildlife and wildlife habitat for ecological restoration. *Restoration Ecology* **9**:251–252.
- Morrison, M. L. 2001b. A proposed research emphasis to overcome the limits of wildlife-habitat relationship studies. *Journal of Wildlife Management* **65**:228–240.
- Morrison, M. L., B. G. Marcot, and R. W. Mannan. 1998. *Wildlife-habitat relationships*. University of Wisconsin Press, Madison.
- Nassauer, J. I. 1995. Messy ecosystems, orderly frames. *Landscape Journal* **14**:161–170.
- Nassauer, J. I. 1997. Cultural sustainability: aligning aesthetics with ecology. Pages 65–83 in J. I. Nassauer, editor. *Placing nature: culture and landscape ecology*. Island Press, Washington, D.C.
- Noss, R. F., and A. Y. Cooperrider. 1994. *Saving nature's legacy*. Island Press, Washington, D.C.
- Packard, S., and C. F. Mutel. 1997. *The tallgrass restoration handbook*. Island Press, Washington, D.C.
- Poole, A., and F. Gill, editors. 2002. *The birds of North America*. Academy of Natural Sciences, Philadelphia, Pennsylvania, and The American Ornithologists Union, Washington, D.C.
- Recher, H. F. 1993. The loss of biodiversity and landscape restoration: conservation, management, survival—an Australian perspective. Pages 141–151 in D. A. Saunders, R. J. Hobbs, and P. Ehrlich, editors. *Nature conservation 3: reconstruction of fragmented ecosystems*. Surrey Beatty & Sons, Chipping Norton, New South Wales, Australia.
- Scott, T. A., W. Wehtje, and M. Wehtje. 2001. The need for strategic planning in passive restoration of wildlife populations. *Restoration Ecology* **9**:262–271.
- SER (Society for Ecological Restoration International Science & Policy Working Group). 2004. *The SER International Primer on Ecological Restoration*. Society for Ecological Restoration International, Tucson, Arizona (available from [www.ser.org](http://www.ser.org)) accessed April 2005.
- Smallwood, K. S. 2001. Linking habitat restoration to meaningful units of animal demography. *Restoration Ecology* **9**:253–261.
- Swetnam, T. W. 1993. Fire history and climate change in giant sequoia groves. *Science* **262**:885–889.
- Thacker, P. D. 2004. California butterflies: at home with aliens. *Bioscience* **54**:182–187.
- Van Driesche, J., and R. Van Driesche. 2000. *Nature out of place*. Island Press, Washington, D.C.
- Van Horne, B. 1983. Density as a misleading indicator of habitat quality. *Journal of Wildlife Management* **47**:893–901.
- Whisenant, S. G. 1999. *Repairing damaged wildlands: a process-oriented, landscape-scale approach*. Cambridge University Press, Cambridge, United Kingdom.
- Whisenant, S. G. 2002. *Terrestrial systems*. Pages 83–105 in M. R. Perrow and A. J. Davy, editors. *Handbook of ecological restoration, volume 1: principles of restoration*. Cambridge University Press, Cambridge, United Kingdom.
- Woodward, J. 2005. Letting Los Angeles go: lessons from feral landscapes. *Landscape Review* **2**:59–69.
- Wooler, R. D., K. C. Richardson, and G. O. Bradley. 1999. Dietary constraints upon reproduction in an obligate pollen- and nectar-feeding marsupial, the honey possum (*Tarsipes rostratus*). *Journal of Zoology, London* **248**:279–287.
- Zavaleta, E. 2000. Valuing ecosystem services lost to Tamarix invasion in the United States. Pages 261–302 in H. A. Mooney and R. J. Hobbs, editors. *Invasive species in a changing world*. Island Press, Washington, D.C.
- Zentner, J., J. Glaspy, and D. Schenk. 2003. Wetland and riparian woodland restoration costs. *Ecological Restoration* **21**:166–173.

**E n d a n g e r e d   E c o s y s t e m s**

**A Status Report  
on America's  
Vanishing Habitat  
and Wildlife**

**By Reed F. Noss and  
Robert L. Peters**

**DECEMBER**

**1995**



wheatgrass, Idaho fescue and other grasses, is also virtually gone<sup>296</sup>. Only one tenth of one percent remains; most of the rest has been plowed and converted to wheat fields or is covered by cheatgrass and other exotic plant species.

The shrub steppe (high desert) of eastern Oregon, western Idaho and the northern Great Basin, was once a shifting mosaic of sagebrush and other shrub and grassland communities. Invasion by alien plants such as cheatgrass and medusahead, livestock grazing and disturbance of the natural fire patterns have destroyed nearly half of this community.

**California Native Grasslands**

California was once covered by 22 million acres of native grassland, of which only one percent remains<sup>297</sup>. The rest have been lost to agriculture, urban development, livestock grazing, fire suppression and exotic species invasions. Specific losses include 99.9 percent of needlegrass steppe, 90 percent of northern coastal bunchgrass, and 94 percent of native grasslands in San

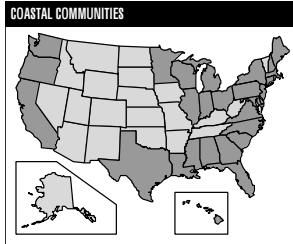
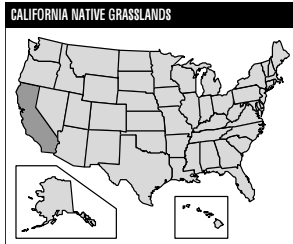
Diego County.

Much of the area once covered by native grasslands has been taken over by exotic species. One source estimates an 8,653 percent increase in acreage covered by exotics since early surveys<sup>298</sup>. Tiny remnants of native grassland can be found on serpentine substrates where the unusual soil chemistry provides a refuge for native plant species better adapted than the invasive exotics. Native species dependent on grasslands have not fared well, including the endangered California condor, San Joaquin kit fox and California jewel flower.

**Coastal Communities in the Lower 48 States and Hawaii**

Coastal communities are vulnerable because they are geographically restricted to narrow strips of habitat which are under intense human pressure. At least 80 percent of the coastline in the lower 48 states has been developed. What few wild shorelines remain are limited to a small part of Maine, the "Big Bend" coast of Florida (along the Gulf of

Mexico where the peninsula meets the panhandle), the Olympic National Park section of the Olympic Peninsula of Washington and smaller stretches in other states. Similarly, the



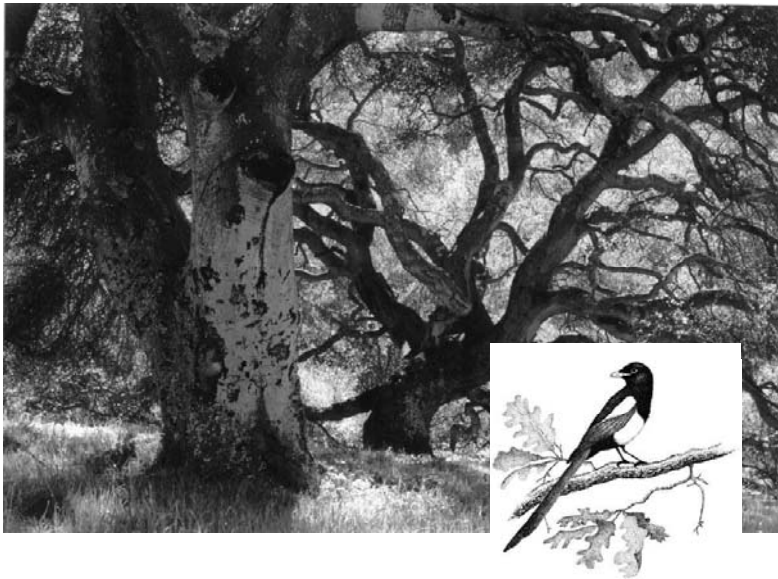
Great Lakes and other lakes have been heavily developed along much of their shores.

Overall, beach and coastal strand communities (occurring on dunes) are the rarest and most



# The Oak Woodland Bird Conservation Plan

*A Strategy for Protecting and Managing  
Oak Woodland Habitats and Associated Birds in California*



*A Project of California Partners In Flight and  
PRBO Conservation Science*



# The Oak Woodland Bird Conservation Plan

*A Strategy for Protecting and Managing  
Oak Woodland Habitats and Associated Birds in California*

Version 2.0

2002

## Conservation Plan Authors

### Lead author:

Dr. Steve Zack  
Conservation Scientist  
North America Program  
Wildlife Conservation Society  
Correspondence:  
1746 NW Hartwell Place  
Portland, OR 97229  
E-mail: SteveZack@msn.com

### Supporting Authors (Point Reyes Bird Observatory):

Grant Ballard  
Mary Chase, Ph.D.  
Gregg Elliott  
Thomas Gardali  
Geoffrey R. Geupel  
Sacha Heath  
Diana Humple  
Mike Lynes  
Melissa Pitkin  
Sandy Scoggin  
Diana Stralberg

### Species Account Authors:

Moe Flannery, PRBO  
Sue Guers, PRBO  
Diana Humple, PRBO  
Colin Lee, PRBO  
Corrina Lu, California PIF  
Mike Lynes, PRBO  
Mark Reynolds, Ph.D., The Nature Conservancy

### Financial Contributors:

David and Lucile Packard Foundation  
California Oak Foundation Members and Friends

### For Further Information:

California Oak Foundation - [www.californiaoaks.org](http://www.californiaoaks.org)  
California Partners in Flight - [www.prbo.org/calpif](http://www.prbo.org/calpif)  
Wildlife Conservation Society - [www.wcs.org](http://www.wcs.org)  
Point Reyes Bird Observatory - [www.prbo.org](http://www.prbo.org)

## Data contributions:

Point Reyes Bird Observatory  
Eastern Sierra Riparian Songbird Conservation Project  
Central Coast Riparian Bird Conservation Project  
Cosumnes Preserve Project  
Sacramento River Project  
Klamath Bird Observatory  
The Nature Conservancy – Cosumnes River Preserve  
California Department of Fish and Game, Wildlife Habitat Relations  
California Interagency Wildlife Task Group  
US Bureau of Reclamation, East Park Reservoir  
Madrone Audubon Society – Mayacamas Preserve  
Hastings Natural History Reservation  
USDA Forest Service, Forestry Sciences Lab, Pacific Southwest Research Station.  
USDA Forest Service, Redwood Sciences Lab, Pacific Southwest Research Station.  
Placer County Planning Department

## Cover Photo:

Steven Jenner, Local Color

## Cover Illustration:

Adrienne Olmstead

## Acknowledgements:

California Partners in Flight wishes to thank the Packard Foundation for funding this important project. Many thanks to everyone who helped write, edit, and publish this document, and also those who contributed data. Many individuals and organizations volunteered time to this project and continue to support the mission of Partners in Flight. Special thanks to those who reviewed part or all of the plan: The California Oak Foundation, Ron Cowan, Walter Koenig, Kathy Purcell, Rich Reiner, Mark Reynolds, and Bill Tietje. Thanks also to Keyt Fischer, Claire Kremen, Kerri Frangioso, Melissa Duncan, David McCauley, Kristin Bruce, Jonathan Richard, Jay Mann, Susan Frankel, Hilary Cooke, John Alexander, Bill Hogoboom, and Colin Lee. Finally, thank you to The Wildlife Society for logistic support in the writing of this document and to the Oak Foundation for funding the first printing of version 2.0.

## Recommended Citation:

CalPIF (California Partners in Flight). 2002. Version 2.0. The oak woodland bird conservation plan: a strategy for protecting and managing oak woodland habitats and associated birds in California (S. Zack, lead author). Point Reyes Bird Observatory, Stinson Beach, CA. <http://www.prbo.org/calpif/plans.html>.

## Table of Contents

<b>Executive Summary</b> .....	<b>8</b>
Biological Need .....	8
Mission and Objective.....	10
Findings and Recommendations .....	11
<b>Chapter 1. Introduction</b> .....	<b>14</b>
Oaks in Peril .....	14
Birds and Oaks .....	15
Partners in Flight.....	15
Objective of the Oak Woodland Bird Conservation Plan .....	16
<b>Chapter 2. Oak Woodland Habitats in California</b> .....	<b>17</b>
Geologic History of Oak Woodlands.....	17
Classification of Oak Woodland Types.....	17
<b>Chapter 3. Conservation Planning Process</b> .....	<b>21</b>
Importance of Oak Habitats for Wildlife .....	21
Focal Species.....	22
Ecological Relationships.....	24
<b>Chapter 4. Problems Affecting Oak Woodland Birds</b> .....	<b>35</b>
Habitat Loss.....	35
Lack of Oak Regeneration.....	35
Fire and Oak Woodlands.....	36
Over-grazing by Cattle .....	37
Sudden Oak Death .....	37
Oak Woodland Viability .....	40
<b>Chapter 5. Species-Specific Recommendations and Population Targets</b> .....	<b>43</b>
Lark Sparrow .....	44
Oak Titmouse .....	45
Acorn Woodpecker .....	46
Western Bluebird .....	48
Blue-gray Gnatcatcher .....	49
Population Targets.....	50
<b>Chapter 6. Bioregional Conservation Objectives</b> .....	<b>54</b>
Sacramento Valley.....	55
San Joaquin Valley .....	56
Modoc.....	57
Klamath .....	57
Central Coast .....	58
Bay-Delta.....	60
South Coast.....	61
Mojave and Colorado Desert.....	61
Sierra .....	61
<b>Chapter 7. Implementation of Conservation Plan Recommendations</b> .....	<b>63</b>
The North American Bird Conservation Initiative .....	63
<b>Chapter 8. Conservation Action Recommendations</b> .....	<b>66</b>
Habitat Protection Recommendations .....	66
Habitat Restoration Recommendations .....	69
Management Recommendations .....	72
Monitoring/Research Recommendations.....	79
Policy Recommendations .....	84

<b>Chapter 9. Outreach and Education</b> .....	<b>86</b>
Project-Based Learning .....	86
Classroom Education .....	87
Volunteer Involvement.....	89
Interpretation at Natural Areas.....	89
Participation in Birding Festivals and Environmental Fairs .....	90
Oak Woodland Outreach .....	90
Future Outreach Priorities.....	93
<b>Chapter 10. Literature Cited and Additional References</b> .....	<b>98</b>
<b>Appendix A. Resources</b> .....	<b>118</b>
<b>Appendix B. How to Monitor Bird Populations</b> .....	<b>124</b>
Research and Monitoring.....	124
Monitoring Strategically .....	125
Long-term Monitoring .....	126
Standardized Methods.....	126
Area Search .....	126
Point Count.....	126
Mist Netting.....	126
Territory Mapping.....	126
Nest Monitoring.....	127

## Tables and Figures

<b>Figure 2-1.</b> Approximate current coverage of oak woodland habitats throughout California based on the California GAP Analysis Project, 1998 and potential coverage based on Kuchler 1976. ....	19
<b>Table 2-1.</b> Approximate current coverage of oak woodland habitat types by bioregion (in hectares) based on California GAP Analysis Project, 1998. ....	20
<b>Table 3-1.</b> Birds associated with oak woodlands in California, with information on their use of acorns, nesting substrate, general foraging habitat in oak woodlands, and whether the species is endemic to California. ....	25
<b>Table 3-2.</b> Essential habitat elements for focal species, based on California Wildlife Habitat Relationships System Version 7.0.1. ....	26
<b>Figure 3-1.</b> PIF monitoring sites, breeding status at these sites, current and historic ranges for the Acorn Woodpecker in California. ....	28
<b>Figure 3-2.</b> PIF monitoring sites, breeding status at these sites, current and historic ranges for the Blue-Gray Gnatcatcher in California. ....	29
<b>Figure 3-3.</b> PIF monitoring sites, breeding status at these sites, current and historic ranges for the Lark Sparrow in California. ....	30
<b>Figure 3-4.</b> PIF monitoring sites, breeding status at these sites, current and historic ranges for the Oak Titmouse in California. ....	31
<b>Figure 3-5.</b> PIF monitoring sites, breeding status at these sites, current and historic ranges for the Western Bluebird in California. ....	32
<b>Figure 3-6.</b> PIF monitoring sites, breeding status at these sites, current and historic ranges for the Western Scrub-Jay in California. ....	33
<b>Figure 3-7.</b> PIF monitoring sites, breeding status at these sites, current and historic ranges for the Yellow-Billed Magpie in California. ....	34
<b>Table 4-1.</b> The Oak Trees (and Tanoak) of California and the presence/absence of conservation problems discussed in the text. ....	42
<b>Table 5-1.</b> Suggested population targets by species and bioregion. ....	51
<b>Table 5-2.</b> Sources of population data in Table 5-1. ....	53



## Executive Summary

This Oak Woodland Bird Conservation Plan is a collaborative effort of California Partners in Flight (CalPIF). It has been developed to guide conservation policy and action on behalf of oak woodland habitats and wildlife. The plan has focused on data concerning bird species that are dependent on oak woodlands, but conservation recommendations have broad applicability for all oak woodland habitats and, if implemented, would benefit many oak woodland species. The plan, which includes both this written document and an associated web site, is meant to provide a source of information on oak woodland bird conservation for landowners, managers, agencies and non-governmental organizations.

This conservation plan, along with the associated Geographic Information System (GIS) database of oak woodland habitats and monitoring data maintained at the Point Reyes Bird Observatory (PRBO), is the first iteration of a continuous process of updating habitat conservation recommendations based on the latest scientific monitoring and research data. This is not a regulatory document, nor does it represent the policies of any agency or organization.

A major extension of this conservation plan is the on-line GIS database of oak woodland monitoring projects and species breeding status available through the CalPIF section of PRBO's website at <http://www.prbo.org/calpif/>. Contributing to and managing data in this database is accomplished through a web interface, to which access is available by request. This database, in particular, is used for cataloguing new information and new analyses and for updating conservation recommendations and goals. Analyses of bird data will be posted on the PRBO website ([www.prbo.org](http://www.prbo.org)), periodically updated, and made available for use by the public. Therefore, this conservation plan is a dynamic, "living" document.

## Biological Need

Oak woodlands have the richest wildlife species abundance of any habitat in California, with over 330 species of birds, mammals, reptiles, and amphibians depending on them at some stage in their life cycle (Verner 1980; Barrett 1980; Block and Morrison 1998). Wilson and others (1991) suggest that California oak woodlands rank among the top three habitat types in North America for bird richness. Oak woodlands are able to sustain such abundant wildlife primarily because they produce acorns, a high quality and frequently copious food supply (Koenig 1990; Ostfeld et al. 1996; McShea and Schwede 1993, and McShea 2000). Oaks also provide important shelter in the form of cavities for nesting (Waters 1988; Purcell 1995). Moreover, oak woodlands are among the most highly prized of California's



Acorn Woodpecker photo by Ian Tait

landscapes, for both aesthetic reasons and utilitarian needs such as firewood collection and grazing.

Yet, as with most of California's native habitats, oak woodlands have not escaped impacts from intensive human settlement: today only two-thirds of California's original oak woodlands remain (approximately 7 million acres). Of those, only about four percent enjoy protected status (Thomas 1997). This trend continues today, through loss of oak woodlands to urbanization and intensive agriculture such as vineyards (Tobin 1999, Larson 1999).

If loss of oak woodlands could be stemmed through protection and management incentives the problem might not be viewed as dire. However, oak woodlands are also faced with more insidious threats. Even today's existing oak woodlands in many cases are not regenerating naturally (i.e. young trees are not establishing to replace older trees as they senesce and die). Thus Californians continue to lose their oak woodland heritage, even in sites that are protected from development.

The causes of lack of natural regeneration are many, varied and inter-related in complex ways that are not completely understood. These include fire suppression (Biswell 1989; Stephens 1997) and overgrazing (Fleischner 1994; Belsky et al. 1999), both of which contribute to invasion of non-native annual grasses and cause long-term changes in habitat structure (Barnhart et al. 1996). Annual grasses tend to outcompete native perennials and young oak seedlings for soil moisture, while herbivory by cattle can also stymie oak sapling development (Hamilton 1997).

The newest threat to California's oak woodlands is Sudden Oak Death (SOD). This pathogen started attacking California oaks in 1985 and became a full-scale epidemic by 1999. In the summer 2000, a previously unknown species of *Phytophthora*, the same genus responsible for the Irish potato famine, was identified as the pathogen causing SOD (Hansen et al. 2000). Oaks of many species infected with SOD die quickly, and there are currently no known cures or prophylactic measures for stopping the disease. The disease is currently present over more than 350 miles of California coastal forests (and into southern Oregon) and will most likely continue to spread (as it has recently to bigleaf maples in the Sierras).

Lack of recruitment of young oaks combined with the SOD epidemic affect 7 of the 10 acorn-bearing species of oak tree in California, including tanoak (Table 4-1). Thus, the combined effect of these two problems on native wildlife populations is likely to be considerable. Surprisingly, several recent assessments of biodiversity and environmental problems in the United States make no special mention of the major problems facing California's oak woodlands (e.g., Noss et al. 1995, Mac et al. 1998, Ricketts et al. 1999, Stein et al. 2000).

## Mission and Objective

The mission of Partners in Flight (PIF) is to stop the decline of, maintain, or increase healthy populations of landbirds in North America. This mission translates into identification of habitat conservation and management priorities for bird species at risk in California, a priority of the associated Joint Ventures. By developing the Oak Woodland Bird Conservation Plan, California PIF (CalPIF) seeks to promote conservation and restoration of oak woodland habitat to support long-term viability and recovery of both native bird populations and other native species. The goals of the CalPIF oak woodland conservation effort are to:

- Define the conservation implications of three key problems facing California's oak woodlands: the long-term lack of recruitment, the new pathogen (*Phytophthora* sp.) that causes Sudden Oak Death, and the loss of oak woodland habitats.
- Collect data and analyze existing scientific information to inform land managers, planners, and the public of the complex and interrelated issues affecting California's oak woodlands and their management.
- Provide technical support for private landowners, land managers (state, federal, and non-profit), funders, agencies, and conservation organizations for assisting in the selection, design, and implementation of the highest priority conservation and land management actions.
- Support and inform efforts to increase the quantity (acreage) and quality (ecosystem function) of oak woodland habitat in California by providing funding information and promoting on-the-ground conservation projects.

Designing conservation efforts for oak woodland habitats based on the needs of birds is useful because birds occupy a diverse range of niches within oak woodlands: from those that nest on the ground to those that nest in the cavities of mature trees, those that feed primarily on insects and those that rely heavily on the acorn mast from year to year. Evidence and experience indicate that by managing for a diversity of birds, diverse oak woodland habitat structure will be maintained and many other elements of terrestrial biodiversity will be conserved (Martin 1995, Askins 2000).

CalPIF recognizes that the subject of land management and land use, whether on private or public lands, can be contentious. Because 85% of all oak woodlands are on private lands (Griffin and Muick 1990), CalPIF supports the need for land managers and landowners to have flexibility to develop systems that accommodate their needs while seeking to achieve the desired habitat characteristics that will maximize benefits to wildlife. CalPIF supports and will seek to maximize the benefits of new and ongoing efforts, such as the Integrated Hardwood Range Management Program, to work with viticulturists, ranchers, and public land managers with the ultimate goal of ensuring a thriving oak woodland heritage for future generations of Californians.

## Findings and Recommendations

This Conservation Plan has been developed collaboratively by the leading bird researchers in California through a process designed to:

- capture the conservation needs of the complete range of oak woodland habitat types throughout the state, and
- develop biological conservation objectives for selected oak woodland bird species.



Lark Sparrow

PRBO

At over 120 sites throughout California, monitoring data on oak woodland birds have been collected continuously over the past ten years. This document places an emphasis on a suite of seven bird species chosen because of their conservation interest to serve as focal species representative of the range of oak habitats in the state (Acorn Woodpecker, Blue-gray Gnatcatcher, Lark Sparrow, Oak Titmouse, Western Bluebird, Western Scrub-Jay, Yellow-billed Magpie). Visit <http://www.prbo.org/calpif/> to view maps of oak woodland habitat coverage, focal

species ranges and PIF monitoring sites in California. Preliminary analyses of the seven focal species' habitat requirements reveal the following:

- Four of seven focal species have experienced significant population declines, local extirpations, or both. The only species that appears to be significantly and consistently increasing is the Western Scrub-Jay, a bird that adjusts readily to urbanization but is also an important nest predator of many other native bird species.
- Loss of habitat or habitat structure (such as dead standing trees, mature trees with cavities, or a shrubby understory component) is implicated as a likely cause of decline and/or other problems for five of the seven focal species.

Accordingly, a series of conservation recommendations are provided, focusing primarily on protection, restoration and management of habitat that will facilitate and promote natural oak woodland regeneration. Other recommendations focus on the need to promote nest success, by retaining mature oaks in altered landscapes to provide nest cavities and by keeping down the number of native and introduced nest predators. Species-specific conservation recommendations for the Western Bluebird, Blue-gray Gnatcatcher and Acorn Woodpecker are also defined.

High priority conservation areas or "portfolio sites," distinguished by their protected status and potential for managing oak woodland habitat through restoration, are identified within

the ten bioregions of California as defined by the California Biodiversity Council. Setting conservation goals by bioregion facilitates planning site-specific projects in a broader context, and provides a comparable framework to other conservation planning efforts such as the North American Bird Conservation Initiative (NABCI). Setting and achieving conservation goals by bioregion will:

- Ensure that a suite of ecological communities representative of California's diversity will be conserved throughout the state.
- Ensure the broadest range of biodiversity and locally adapted races of species will be conserved.
- Facilitate action at the local level.

California's Oak Woodland Conservation Act provides funds for protection and conservation of oak woodlands. This program is administered by the Wildlife Conservation Board. It offers financial incentives to private landowners to protect and promote biologically functional oak woodlands over time. Conservation easements, land improvements, public education and outreach are some of the activities that may be funded by AB 242, initiated by the California Oak Foundation and carried by Assemblywoman Helen Thomson.

Finally, scientific efforts for conservation have little impact without the support of affected local communities, including private landowners, government land managers, and the general public (Askins 2000). This is particularly true for oak woodlands in California, which are 85% privately owned. To gain crucial public support, research and management programs must share their findings and involve the interested parties at all levels of the conservation enterprise. Therefore, this plan provides a list of current programs focusing on oak woodland conservation and management, educational and volunteer opportunities for children and adults, and a list of resources and organizations for those interested in involving their families and communities in oak woodland conservation.

### Species Account Authors:

**Acorn Woodpecker (*Melanerpes formicivorus*)** by Corrina Lu and Colin Lee, California Partners In Flight

**Blue-gray Gnatcatcher (*Poliophtila caerulea*)**, by Diana Humple, Point Reyes Bird Observatory

**Western Scrub-Jay (*Apelocoma californica*)** by Sue Guers, Point Reyes Bird Observatory

**Yellow-billed Magpie (*Pica nuttalli*)** by Mark Reynolds, Ph.D., The Nature Conservancy

**Oak Titmouse (*Baeolophus inornatus*)** by Moe Flannery, Point Reyes Bird Observatory

**Western Bluebird (*Sialia mexicana*)** by Mike Lynes, Point Reyes Bird Observatory

**Lark Sparrow (*Chondestes grammacus*)** by Diana Humple, Point Reyes Bird Observatory

**California Partners in Flight Executive Steering Committee:**

- Audubon California
- California Department of Fish & Game (CDFG)
- Department of Defense/U.S. Navy
- Klamath Bird Observatory (KBO)
- Institute for Bird Populations
- National Fish & Wildlife Foundation (NFWF)
- National Park Service (NPS)
- Natural Resources Conservation Service (NRCS)
- PRBO Conservation Science (PRBO)
- San Francisco Bay Bird Observatory (SFBBO)
- The Nature Conservancy (TNC)
- U.S.D.A. Forest Service (USFS)
- U.S. Bureau of Land Management (BLM)
- U.S. Bureau of Reclamation (BOR)
- U.S. Fish & Wildlife Service (USFWS)
- U.S. Geological Survey (USGS)
- Wildlife Conservation Society (WCS)
- Ventana Wilderness Society/Big Sur Ornithology Lab



**Chapter 1. Introduction**

The quintessential landscape of California is oak woodland. Oaks are the central features of the landscape that most Californians identify with. Yet, California's oak woodlands are imperiled in many ways. Moreover, the forces that put California's oaks at risk endanger the birds and other wildlife dependent upon them.



Blue Oak Woodland

photo by Sandy Scoggin, PRBO

**Oaks in Peril**

The conservation concerns outlined here for oak woodlands, particularly the consequences of Sudden Oak Death, the lack of regeneration of several oak species, and the loss of oak habitat to development seem to be harbingers of the future for all the wildlife of California's oak woodlands.

## Birds and Oaks

The birds of California's oak woodlands are connected to this distinctive habitat mainly through acorns, the fruits of oaks that are eaten and stored by dozens of species. This ecological relationship is reciprocal: species like Western Scrub-Jays, Steller's Jays, and Yellow-billed Magpies do not completely retrieve cached acorns and thus act as dispersers of oak seedlings across the landscape. In crucial ways, oaks provide key food for many birds, and some birds provide seed dispersal for oaks. Large oak trees also provide cavities for cavity-dependent nesting birds and other wildlife, as well as caching sites for acorn woodpeckers, nuthatches, and other species. Additionally, oaks commonly host mistletoe, which is an important food for Western Bluebirds, Phainopepla, and other species. The ties between oaks and birds are profound and diverse.



Coast Live Oak photo by Rich Stallcup

As is true for most natural landscapes, the loss of oak woodland habitat continues as our ever-growing population converts ranches into suburbia, foothills into vineyard, and forest into prime real estate. Further, the lack of recruitment of new oaks in many species represents a crisis in the making, but one that is not currently widely acknowledged. Nonetheless, our existing oak woodlands are frequently not regenerating new oaks to replace the old ones. Finally, a new threat dubbed "Sudden Oak Death," or SOD, is killing coastal oaks and tanoaks. This new pathogen represents a very urgent crisis indeed. The majority of California's oak tree species are affected either by lack of regeneration or SOD, or both (Table 4-1).

## Partners in Flight

This Oak Woodland Bird Conservation Plan is part of a series of California Partners in Flight (CalPIF) Bird Conservation Plans. Bird scientists and ecologists working in oak woodlands have attempted to bring an understanding of these threats to California's oak woodlands and to discern how these issues are affecting and will affect the birds that are an integral part of these ecosystems. Perhaps unlike other CalPIF Conservation Plans, the primary focus here is on habitat problems over the immediate problems of the birds that inhabit them, but like other plans, conservation solutions are generally habitat based.

The Oak Woodland Bird Conservation Plan is an outgrowth of the national movement known as Partners in Flight (PIF). It is a plan produced by California Partners in Flight. CalPIF was formed in 1992 with the full participation of state, federal, and private land managers, scientists, and researchers interested in the conservation of nongame landbirds. Recognizing that the major cause of population declines in California was due to habitat loss, CalPIF began identifying critical habitats important to birds. The first effort was on riparian

habitat (see the "Riparian Bird Conservation Plan", PRBO website [www.prbo.org](http://www.prbo.org) for current information).

## Objective of the Oak Woodland Bird Conservation Plan

The objective of the Oak Woodland Bird Conservation Plan is to promote conservation and restoration of oak woodland habitat in California to support the long-term viability and recovery of native bird populations and the associated natural diversity tied to oak woodlands. The main goals of our endeavor are to:

- Present an overview of the conservation implications of three key problems facing California's oak woodlands: the long-term lack of recruitment of many species of oaks and the recent pathogen (*Phytophthora* sp.) threat to tanoaks, coast live oak, interior live oak, and black oak (Sudden Oak Death), and the loss of oak woodland habitats.
- Collect data and analyze existing scientific information to help inform land managers, planners, and the public of the complex and interrelated issues affecting California's oak woodlands and their management.
- Provide technical support for private landowners, land managers (state, federal, and non-profit), funders, agencies, and conservation organizations for assisting in the selection, management design, and implementation of the highest priority conservation/land management projects and activities.
- Support and inform efforts to increase the quantity (acreage) and quality (ecosystem function); i.e., facilitate the regeneration of oaks and restoration of native perennial grasses) of oak woodland habitat in California by identifying and promoting on-the-ground conservation activities and projects (ones that are demonstrating success in habitat restoration and recruitment).





## Chapter 2. Oak Woodland Habitats in California

### Geologic History of Oak Woodlands

Oaks appeared in southwestern North America, including California, beginning in the Eocene (ca. 50+ million years before present) (Axelrod 1988). The history of oaks and oak woodlands in geologic time in California is a complicated one of community assembly and disassembly with the vicissitudes of climate change. In general, oaks increase in prominence in warmer, drier conditions, and decline in cooler, wetter conditions (Axelrod 1988). By the Miocene (ca. 24 million years before present) many of California's present oak species were evident (e.g., tanoak, coast live oak, interior live oak, blue oak, and valley oak).

Finer-scale fluctuations in oak abundance and distribution are evident in the Holocene (from 10,000 years ago to the present), as shown in pollen studies (Byrne et al. 1991). Oaks began to reestablish themselves following the last glacial period in California. Oaks were more abundant than at present during the mid-Holocene (ca. 6,000 years ago).

### Classification of Oak Woodland Types

Oaks are in the plant family Fagaceae. The members of this family include *Lithocarpus* (tanoaks, the majority of species (ca. 300) are in Asia), *Castanopsis* (now more frequently referred to as *Chrysolepis*) (the chinquapins), *Castanea* (chestnuts), and *Quercus* (oaks). All produce hardened fruits. Hardened fruit evolution in the Fagaceae and related families, the associated dispersal of such fruits by vertebrates, and a great explosion of plant diversity among such families all occurred in the Eocene (Tiffney 1986). *Lithocarpus* is considered the most plesiomorphic ("primitive") while *Quercus* is considered the most apomorphic ("advanced"), as evidenced from floral morphology (Kaul 1986).

There is a long history of classification of present vegetation in California (see review in Sawyer and Keeler-Wolf 1995). Holland (1986) identified 18 natural communities dominated by oaks in California. Six are forest communities (e.g., coast live oak riparian forest), four are chaparral communities (e.g., scrub oak chaparral), and eight are woodland and savanna communities (e.g., blue oak woodland and Oregon oak woodland).

In their own treatment of California vegetation, Sawyer and Keeler-Wolf (1995) note no fewer than 15 series of oak dominated by shrubs and 14 series of oak (and tanoak) dominated by trees; a total of 81 tree series are described in total. Among the tree series, the black oak, blue oak, coast live oak, mixed oak, Oregon white oak, tanoak, and valley oak series occur over significantly large areas of California.

Griffin (1988) noted that oak woodlands have "little floristic unity", but nonetheless partitioned oak woodlands broadly into "Foothill Woodland", "Southern Oak Woodland", "Northern Oak Woodland", and "Riparian Forest" region, with each category having several subcategories, or phases. In the Foothill type, valley oak, blue oak, and interior live oak predominate. It is in the Southern oak woodland type that we find coast live oak. Griffin's

main emphasis, however, is that oak woodland represents an "ill-defined zone of oak-dominated communities growing between open grassland and montane forest."

Thus, for our purposes, we define oak woodlands as simply those forests or woodlands where oaks (or tanoaks) are common or predominate. We wish instead to emphasize that for wildlife, including the bird community, the key issue of oak woodlands is not so much in the detail of which oak species are present, but rather that all oaks (and tanoaks) produce acorns. Acorns are perhaps the most important food product for wildlife produced in California's many diverse habitats.

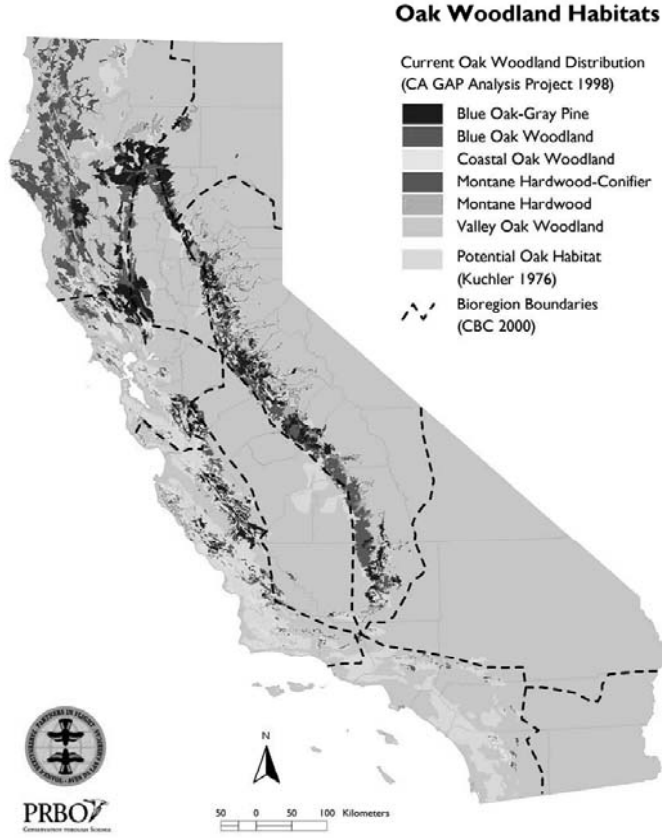


Blue Oak Acorns

photo by Steve Zack, Wildlife Conservation Society

The diverse oak woodland types in California support a range of bird communities. For example, coastal oak forests in western California support high breeding densities of forest species, such as Dark-eyed Juncos, that are not common in oak savanna habitats further inland, although both habitats support many oak-associated species such as Oak Titmouse (Tietje and Vreeland 1997, Verner et al. 1997).

**Figure 2-1.** Approximate current coverage of oak woodland habitats throughout California based on the California GAP Analysis Project, 1998 and potential coverage based on Kuchler 1976. See back cover for color version of this map.



**Table 2-1.** Approximate current coverage of oak woodland habitat types by bioregion (in hectares) based on California GAP Analysis Project, 1998<sup>a</sup>.

	Klamath	Modoc	Sacramento Valley	Sierra	Bay/Delta
Blue Oak / Gray Pine	475,068	137,409	81,639	479,547	84,644
Blue Oak Woodland	286,506	78,650	44,781	547,501	27,581
Coastal Oak Woodland	40,183	0	18,896	0	119,425
Montane Hardwood / Conifer	985,011	22,315	0	23,027	68,019
Montane Hardwood	401,129	25,988	34,564	352,588	110,044
Valley Oak Woodland	64,531	0	9399	31,049	76,232
<b>% Covered by Oak Woodland</b>	<b>34.8%</b>	<b>7.9%</b>	<b>12.6%</b>	<b>17.7%</b>	<b>21.3%</b>

	San Joaquin Coast	Central Coast	Mojave	South Coast	Colorado Desert	California Total
Blue Oak / Gray Pine	9210	215,811	3453	0	0	1,966,477
Blue Oak Woodland	23,286	131,707	2458	0	0	1,690,086
Coastal Oak Woodland	0	153,465	0	40,561	262	372,830
Montane Hardwood / Conifer	0	17,477	0	19,209	341	1,158,540
Montane Hardwood	1322	59,469	2793	16,580	1108	1,358,275
Valley Oak Woodland	1653	72,728	657	0	0	287323
<b>% Covered by Oak Woodland</b>	<b>1.3%</b>	<b>21.8%</b>	<b>0.1%</b>	<b>2.9%</b>	<b>0.1%</b>	<b>13.2%</b>

<sup>a</sup> Davis et al. (1998)



### Chapter 3. Conservation Planning Process

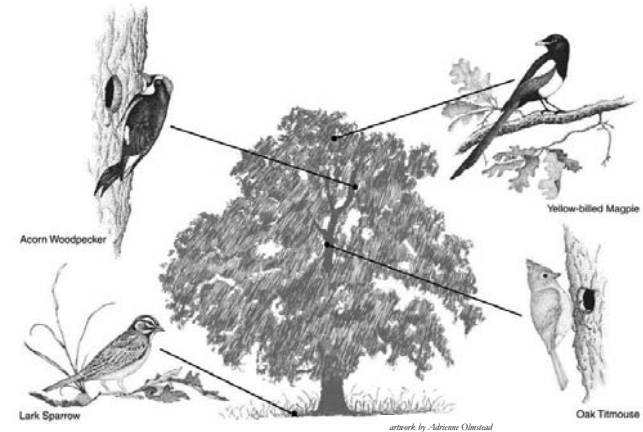
Oak woodlands are thought to have the richest wildlife species abundance of any habitat in California, as some 331 species depend on this habitat to varying degrees (Verner 1980; Barrett 1980; Block and Morrison 1998). The key connection between much of the wildlife and oak woodlands is through the oak's production of acorns. Acorn production varies in time and space between and among species (Sork and Bramble 1993; Healy et al. 1999), including species in California (Koenig et al. 1994). So-called "mast" years in oaks, when acorn production is copious in an area, are critical to triggering pulses in vertebrate populations and reproduction (Koenig 1990; Ostfeld et al. 1996; McShea and Schwede 1993; and McShea 2000). Forests with at least some oaks have higher mean vertebrate diversity than similar forests without oaks (Rosenstock 1998). This difference is due both to acorn production and the increased cavity-nesting sites afforded by large oak trees in the landscape.

#### Importance of Oak Habitats for Wildlife

Large oak trees in oak woodland habitats are important for cover, nesting sites for cup nesting species and cavity nesting species, as well as caching sites for birds storing acorns. In oak woodlands with large oaks, the abundance of cavity nests is important to many species of wildlife, including birds (Waters 1988; Purcell 1995). Old, large oak trees are mosaics of living and dead branches, providing ample sites for woodpeckers to excavate cavities. Dead branches and trunks in both living and dead large oaks are critically important for storage sites of acorns by Acorn Woodpeckers (Gutierrez and Koenig 1978).

There are a few studies of bird communities in California's oak woodlands (Block 1989; Block et al. 1990; Tietje et al. 1997; Verner et al. 1997; Sisk et al. 1997). These studies indicate many of the ecological connections between oak woodlands and birds. They make clear the strong link between the bird community and the production of oaks (through acorn dispersal), the importance of cavity nests in large trees, and the often complex interactions and connections between habitat features and bird species.

Fragmentation studies and efforts to identify minimal size and shape requirements of oak woodland habitat are few but important (see for example Aigner et al. 1998, Merenlender et al. 1998, Stralberg and Williams, 2002). Land managers need to know tradeoffs in habitat size and the consequences for wildlife. Restoration efforts can also be guided by knowing how many species might be present with what effort of scale.



#### Birds in Oak Woodlands

This schematic shows nest placement for four of the plan's focal species. Studies show a strong link between the bird community and the production of oaks (through acorn dispersal), the importance of cavity nests in large trees, and the often complex interactions and connections between habitat features and bird species.

#### Focal Species

Because birds occupy a wide diversity of ecological niches, they serve as useful tools in the design of conservation efforts (Martin 1995, Askins 2000). Birds are relatively easy to monitor in comparison with other taxa and can serve as "focal species", whose requirements define different spatial attributes, habitat characteristics and management regimes representative of a healthy system. For example, the bird that requires the largest area to survive in a certain habitat will determine the minimum suitable area for that habitat type. Likewise, the requirements of non-migratory birds that disperse short distances to establish new territories will define the attributes of connecting vegetation. The species with the most demanding or exacting requirements for an ecological characteristic such as territory size determines its minimum acceptable value in an area that is protected or managed for biodiversity. Therefore, the assumption is that a landscape designed and managed to meet the focal species' needs encompasses the requirements of other species (Lambeck 1997).

Because focal species lists are explicitly based on numerous hypotheses and assumptions, the choice of focal species should be tested as part of the ongoing adaptive conservation planning process. Thus, this oak woodland focal list may be revised in the future to include new species identified by research and monitoring.

Twenty-two bird species were selected by consensus as “focal species” for preparing the Oak Woodland Bird Conservation Plan. The focal species list for oak woodlands includes both a suite of species representing various habitat elements and ecological characteristics and a number of species that are good indicators for monitoring (species that are common and respond strongly and/or consistently to habitat attributes). Unlike the Riparian Bird Conservation Plan, none of the “focal species” have any special status designations. Species accounts have been prepared, or are in process, for the following bird species:

#### Focal Species and Species Account Authors:

- **Acorn Woodpecker (*Melanerpes formicivorus*)** by Corrina Lu and Colin Lee, California Partners In Flight
- **Blue-gray Gnatcatcher (*Poliophtila caerulea*)**, by Diana Humple, Point Reyes Bird Observatory
- **Western Scrub-Jay (*Apelocoma californica*)** by Sue Guers, Point Reyes Bird Observatory
- **Yellow-billed Magpie (*Pica nuttalli*)** by Mark Reynolds, Ph.D., College of Sciences, San Diego State University
- **Oak Titmouse (*Baeolophus inornatus*)** by Moe Flannery, Point Reyes Bird Observatory
- **Western Bluebird (*Sialia mexicana*)** by Mike Lynes, Point Reyes Bird Observatory
- **Lark Sparrow (*Chondestes grammacus*)** by Diana Humple, Point Reyes Bird Observatory

Additional focal species of similar conservation concern have been identified, but species accounts have not yet been completed for these species. We anticipate and encourage future accounts for these species.

#### Additional Focal Species:

- **Wood Duck (*Aix sponsa*)**
- **Red-shouldered Hawk (*Buteo lineatus*)**
- **Wild Turkey (*Meleagris gallopavo*)**
- **California Quail (*Callipepla californica*)**
- **Band-tailed Pigeon (*Columba fasciata*)**
- **Northern Pygmy Owl (*Glaucidium gnoma*)**
- **Lewis Woodpecker (*Melanerpes lewis*)**
- **Nuttall’s Woodpecker (*Picoides nuttalli*)**
- **Ash-throated Flycatcher (*Myiarchus cinerascens*)**

- **Hutton’s Vireo (*Vireo huttoni*)**
- **White-breasted Nuthatch (*Sitta carolinensis*)**
- **Bewick’s Wren (*Thryomanes bewickii*)**
- **California Thrasher (*Toxostoma redivivum*)**
- **European Starling (*Sturnus vulgaris*)**
- **California Towhee (*Pipilo crissalis*)**

#### Ecological Relationships

The birds on our lists represent diverse ecological relationships with California’s oak woodlands (Tables 3-1 and 3-2). Many of the bird species consume acorns. Clearly, species like Acorn Woodpeckers (Koenig 1990), Western Scrub-Jay and Oak Titmouse are highly

dependent on acorns. Verner (1980) names 30 bird species as consumers of acorns, six of which have diets that are more than 25% acorns. Acorn Woodpeckers and Western Scrub-Jays cache (store) many thousands of acorns annually. Western Scrub-Jay individuals may store as many as 5,000



Western Scrub-Jay

photo by Steve Zack  
Wildlife Conservation Society

acorns annually (Vander Wall 1990), whereas a population of Acorn Woodpeckers may store up to 43,000 in a year (Koenig 1990; Vander Wall 1990). The Western Scrub-Jay, Steller’s Jay (not on our lists; see Fuchs et al. 1997), and, to a lesser degree, the Yellow-billed Magpie cache acorns individually in the ground, and thus, among caching birds, are the only species to facilitate regeneration because many acorns remain unretrieved and germinate.

**Table 3-1.** Birds associated with oak woodlands in California, with information on their use of acorns, nesting substrate, general foraging habitat in oak woodlands, and whether the species is endemic to California.

Species	Consumes Acorns?	Caches Acorns?	Nest <sup>1</sup>	Foraging Habitat in Oak Woodlands	California Endemic?
Wood Duck	Yes		2 <sup>o</sup> Cavity	Wooded Streams	
Red-shouldered Hawk			Platform	Woodlands	?
Wild Turkey (I <sup>2</sup> )	Yes		Ground	Woodlands	
Band-tailed Pigeon	Yes		Platform	Woodlands	
California Quail	Yes		Ground	Woodland-shrub	
N. Pygmy Owl			2 <sup>o</sup> Cavity	Woodlands	
Acorn Woodpecker	Yes	Tree, many	1 <sup>o</sup> Cavity	Woodlands	
Lewis Woodpecker	Yes		1 <sup>o</sup> Cavity	Woodlands	
Nuttall's Woodpecker	Yes		1 <sup>o</sup> Cavity	Woodlands	YES <sup>3</sup>
Ash-throated Flycatcher			2 <sup>o</sup> Cavity	Open Woodlands	
Western Scrub-Jay	Yes	Ground, many	Cup	Woodland-Scrub	
Yellow-billed Magpie	Yes	Ground, few	Cup	Woodlands	YES
Oak Titmouse	Yes	Tree, few	2 <sup>o</sup> Cavity	Woodlands	YES <sup>3</sup>
White-breasted Nuthatch	Yes	Tree, few	2 <sup>o</sup> Cavity	Woodlands	
Bewick's Wren			2 <sup>o</sup> Cavity	Woodland-Scrub	
Blue-gray Gnatcatcher			Cup	Woodlands	
Western Bluebird			2 <sup>o</sup> Cavity	Open Woodlands	
California Thrasher			Cup	Woodland-Scrub	YES <sup>3</sup>
European Starling (I)			2 <sup>o</sup> Cavity	Agriculture edge	
Hutton's Vireo			Cup	Woodlands	
California Towhee			Cup	Woodland-Scrub	YES <sup>4</sup>
Lark Sparrow			Ground	Grass - Woodland	

**Notes:** 1. Cavity nesting species differ as to whether they excavate their own cavities (1<sup>o</sup> cavity nester) or they take over disused nests or naturally occurring cavities (2<sup>o</sup> cavity nester). 2. (I) denotes an introduced, nonnative species. 3. Also occurs in Baja California, Mexico. 4. Also occurs in Baja California, Mexico, and extreme southern Oregon.

**Table 3-2.** Essential habitat elements for focal species, based on California Wildlife Habitat Relationships System Version 7.0.<sup>1</sup>

Focal species	Acorns	Cavities	Trees	Shrub	Grass/ herb	Snags	Brush piles	Water/ Riparian
Wood Duck		X						X
California Quail			X	X	X			X
Red-shouldered Hawk			X	X			X	X
Northern Pygmy Owl		X	X			X		
Band-tailed Pigeon	X		X					
Acorn Woodpecker	X	X	X			X		X
Lewis's Woodpecker	X	X	X			X		
Nuttall's Woodpecker		X	X					
Ash-throated Flycatcher		X	X	X				
Western Scrub-Jay	X		X	X				X
Yellow-billed Magpie	X		X			X		
Oak Titmouse		X	X			X		
White-breasted Nuthatch	X		X			X		
Bewick's Wren		X	X	X				
Blue-gray Gnatcatcher			X	X				
California Thrasher				X				
Western Bluebird		X	X	X	X	X		X
Hutton's Vireo			X	X				X
Lark Sparrow					X			
California Towhee				X				X

<sup>1</sup> Includes selected elements classified by CWHHR as "essential" or "secondarily essential".

Half of the birds on our lists are cavity-nesting species. Their dependency on particularly large oak trees, with their mosaic of live and dead branches, the latter containing the cavities for nesting, cannot be overestimated (Purcell 1995). Acorn Woodpeckers are the most common cavity excavating species in oak woodland habitats, particularly the valley, blue, black and interior live oak woodlands. The secondary cavity nesting species, those that do not excavate their own cavities, typically appropriate unused woodpecker nesting cavities. Cavities can and often are used for many years, often by many species over time.



Acorn Woodpecker photo by Ian Tait

Several bird species were chosen that respond to specific types of understory habitat within oak woodlands, including Lark Sparrow, Bewick's Wren, and California Quail. The list also includes several species that are sensitive to habitat fragmentation and residential development density: Lark Sparrow and Ash-throated Flycatcher respond negatively, and Western Scrub-jay responds positively (Stralberg and Williams, 2002).

Several bird species on our lists are endemic (unique to California, or nearly so (it is uncertain whether Red-shouldered Hawks of California are distinct from eastern hawks). And, of these, the Nuttall's Woodpecker, Yellow-billed Magpie, and Oak Titmouse are intricately tied to oak woodlands specifically. Several birds on our focal list use habitat elements such as woody debris or shrubs (Bewick's Wren, California Towhee) and others use wetland or riparian habitat elements (Red-shouldered Hawk and Wood Duck). These components of oak woodland habitats are also important to many species of mammals, amphibians and reptiles in oak woodlands.

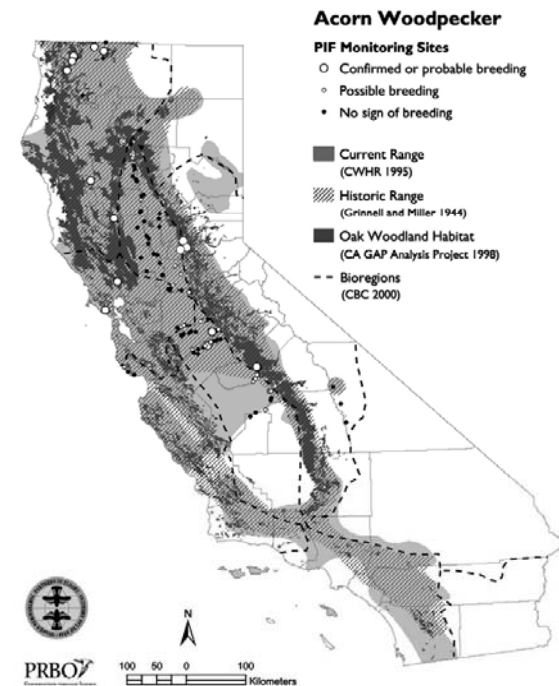


Nuttall's Woodpecker photo by Ian Tait

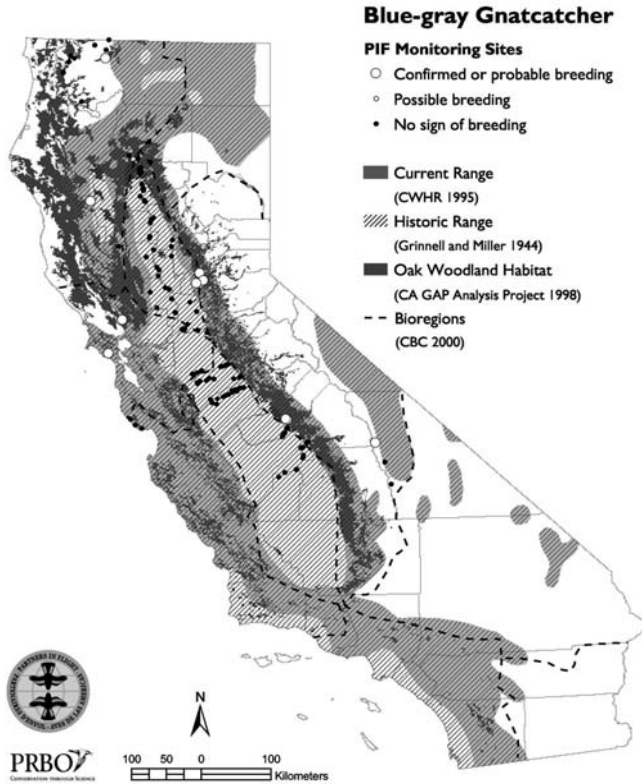
Two species are non-native, and enter our list and consideration for different reasons. The Wild Turkey is an important game bird in California and an important consumer of acorns. The European Starling is included because it is a major competitor for cavities in oak woodlands. It is typically more aggressive than other species, and so prevents native cavity nesting species from accessing nesting sites. As many of our oak woodlands abut agricultural areas, they are susceptible to colonization by Starlings - an abundant pest with which our native species must contend.

Figures 3-1 through 3-7 show oak woodland distribution in California based on the California GAP Analysis (Davis 1998), current range, historic range, study sites and breeding status at these sites for the primary focal species, Acorn Woodpecker, Blue-gray Gnatcatcher, Lark Sparrow, Oak Titmouse, Western Bluebird, Western Scrub-Jay, and Yellow-billed Magpie.

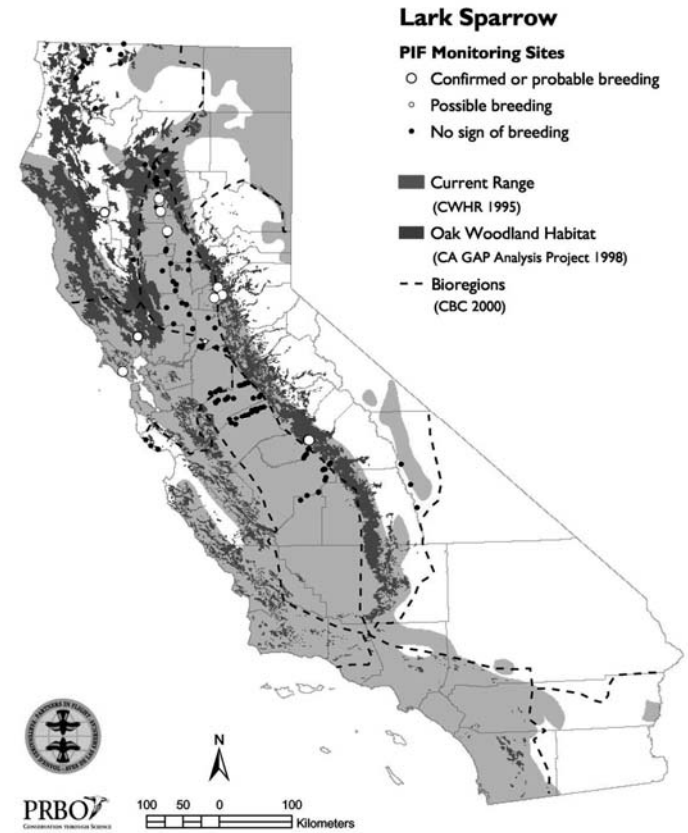
**Figure 3-1.** PIF monitoring sites, breeding status at these sites, current and historic ranges for the Acorn Woodpecker in California. Please see [www.prbo.org/calpif/maps.html](http://www.prbo.org/calpif/maps.html) for interactive color focal species maps.



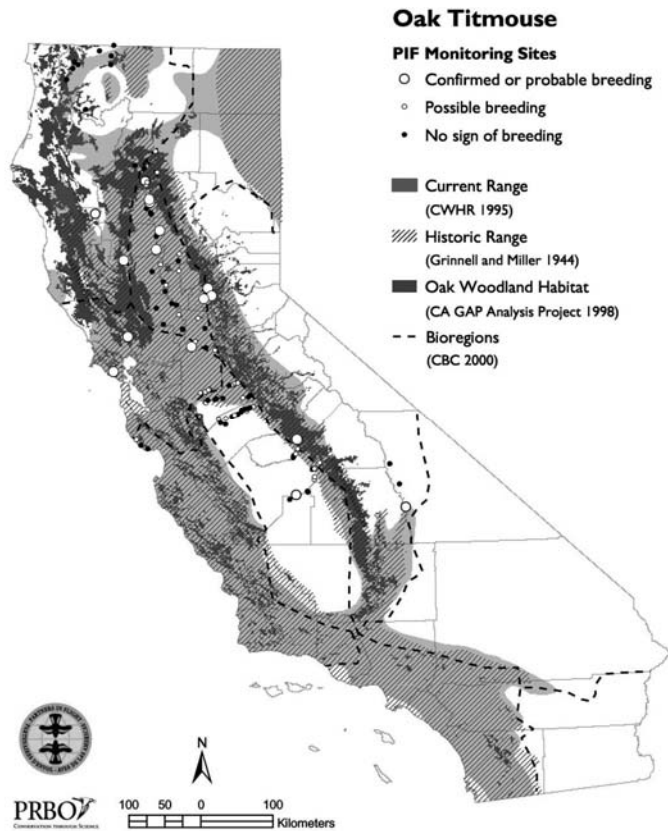
**Figure 3-2.** PIF monitoring sites, breeding status at these sites, current and historic ranges for the Blue-Gray Gnatcatcher in California. Please see [www.prbo.org/calpif/maps.html](http://www.prbo.org/calpif/maps.html) for interactive color focal species maps.



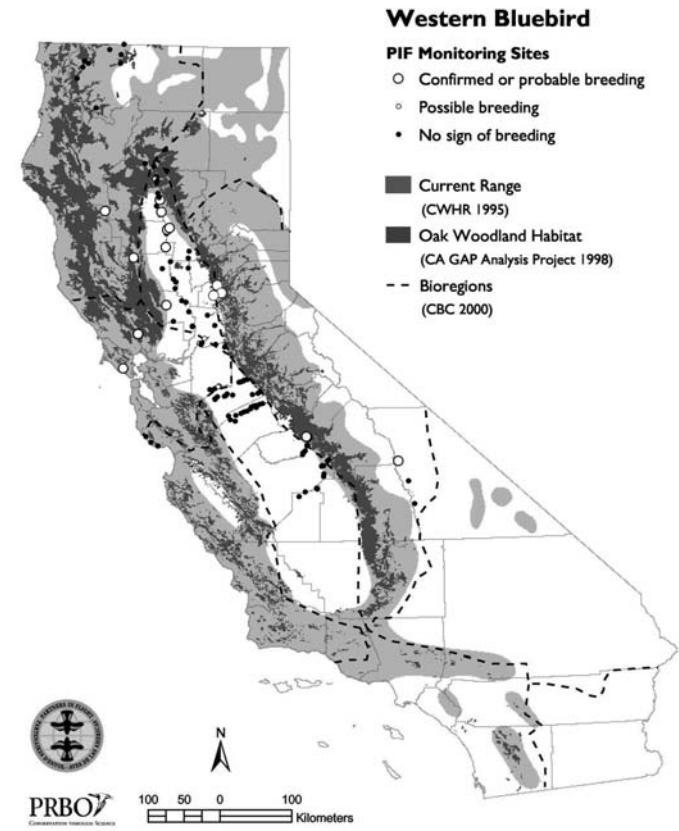
**Figure 3-3.** PIF monitoring sites, breeding status at these sites, current and historic ranges for the Lark Sparrow in California. Please see [www.prbo.org/calpif/maps.html](http://www.prbo.org/calpif/maps.html) for interactive color focal species maps.



**Figure 3-4.** PIF monitoring sites, breeding status at these sites, current and historic ranges for the Oak Titmouse in California. Please see [www.prbo.org/calpif/maps.html](http://www.prbo.org/calpif/maps.html) for interactive color focal species maps.

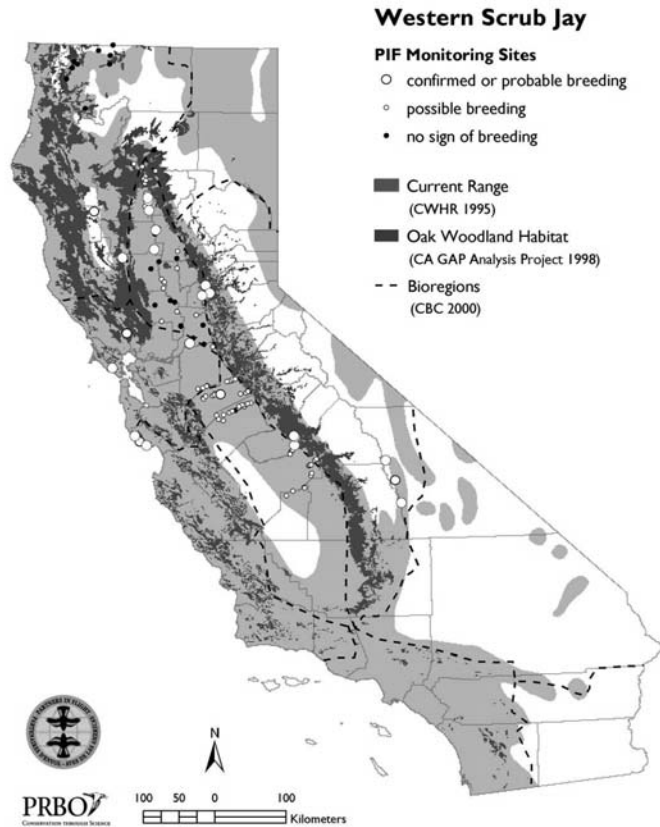


**Figure 3-5.** PIF monitoring sites, breeding status at these sites, current and historic ranges for the Western Bluebird in California. Please see [www.prbo.org/calpif/maps.html](http://www.prbo.org/calpif/maps.html) for interactive color focal species maps.

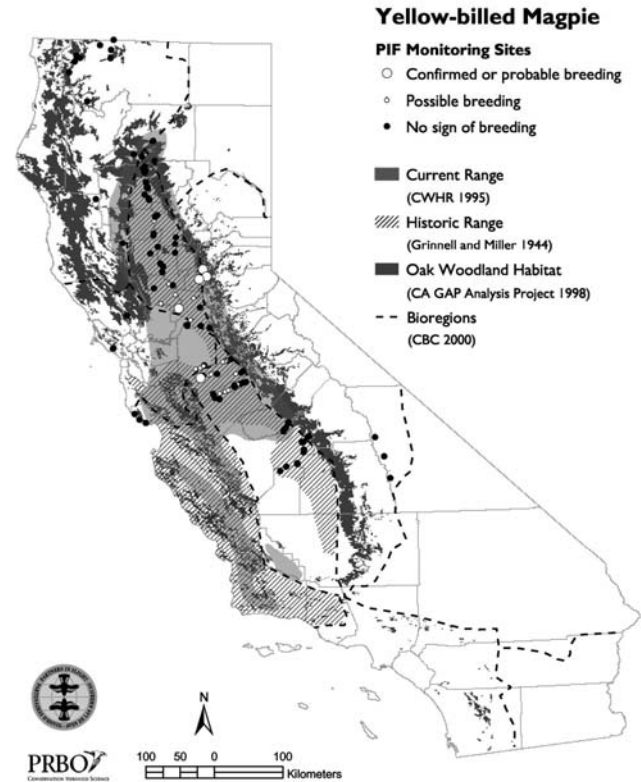




**Figure 3-6.** PIF monitoring sites, breeding status at these sites, current and historic ranges for the Western Scrub-Jay in California. Please see [www.prbo.org/calpif/maps.html](http://www.prbo.org/calpif/maps.html) for interactive color focal species maps.



**Figure 3-7.** PIF monitoring sites, breeding status at these sites, current and historic ranges for the Yellow-Billed Magpie in California. Please see [www.prbo.org/calpif/maps.html](http://www.prbo.org/calpif/maps.html) for interactive color focal species maps.





## Chapter 4. Problems Affecting Oak Woodland Birds

### Habitat Loss

More than a third of all oak woodlands have been lost since the settlement of California by Europeans; of an estimated 10-12 million acres, only some seven million remain. Of the remaining oak woodlands, most have been modified or degraded, and only about four percent are formally protected (Thomas 1997). Most of the loss of oak woodlands has been due to the ever-increasing urban and suburban growth of California. The city of Oakland, the town of Thousand Oaks, and many other town names recall the former prevalence of oak woodlands, and their importance to earlier communities. The clearing of oaks has also been done on ranches to “improve” forage quantity (Bolsinger 1988), and for firewood (Bolsinger 1988; Griffin and Muick 1990; Aigner et al. 1998).



Yellow-billed Magpie on oak stump photo by Ian Tait

A comparatively new challenge to conservation of oak woodlands is loss to expanding vineyards. A recent example in Santa Barbara County where a prominent winery removed a small grove of oaks, causing a backlash among citizens (Van de Kamp 1996, 1997; Burns 1998a, b; Sage 1998a, b), provides evidence for the value that Californians place on their remaining woodlands and large oak trees. The accelerated clearing of oak trees in rural areas of Santa Barbara County led to the initiation of a collaborative process to develop a new oak protection ordinance (Leider in press). The wine industry is attempting to come to grips with this conflict of economic growth and the aesthetic and biological effects of oak clearing (Tobin 1999; Larson 1999). For example, the California Association of Winegrowers (CAWG) hosted a workshop on the interaction between wildlife and vineyards in February 2002. CAWG plans to publish a guide to wildlife-friendly vineyard management that will present case studies and resources for growers. Adina Merenlender and others from the Integrated Hardwood Range Management Program are working with vineyard owners to identify ways to manage oaks in and around vineyards (Merenlender et al, 1998).

### Lack of oak regeneration

A major threat to the oak woodlands of California is that several species have experienced very little regeneration this past century (White 1966; Griffin 1971, 1976). This general problem is not unique to California (Watt 1919, for problems in Britain’s oak woodlands). The problem is not in acorn production or acorn viability, rather it is in the inability of seedlings to survive to become young trees (Borchert 1990). The causes and influences of this phenomenon are many and interconnected. It is a “cryptic” conservation crisis because it is not clearly evident as one looks across the oak woodland landscapes that surround so many of California’s population centers. The classic park-like appearance of many oak

woodlands seems intact – large trees spreading over grassy areas. But, upon closer inspection, little to no young trees are growing. In fact, in many areas, small trees are old trees of suppressed growth, not recent recruits. The consequence for several species of oaks is that existing trees will senesce, die and not be replaced unless there is active management for a different outcome.

There are several factors that contribute to this problem, and each interacts with others in ways that are often not fully understood. The factors include fire suppression, cattle grazing, invasion of European weedy annual grasses that have largely replaced native perennial grasses, and herbivory of oak shoots by cattle and native mammals.

The tree oaks known to have serious problems with lack of regeneration include valley oak (Thompson 1961), blue oak (Swiecki and Berhardt 1998), coast live oak (Parikh and Gale 1998), and island oak (Pavlik et al. 1991) (Latin names are provided in Table 4-1). Grazing pressure is greatest where valley oak and blue oak occur. Some regeneration problems have been observed in some regions for black oak. There has been intensive research and some multiple management solutions to the recruitment problem. There is a large and diverse literature available on facilitating regeneration in oak trees, through such diverse means as seedling shelters from grazing, prescribed fire, progressive cattle management and other techniques that vary in management intensity (Adams et al. 1997; Alpert et al. 1999; Bernhardt and Swiecki 1997; Borchert 1990; Callaway 1992a,b; Gordon and Rice 1993; Griggs and Peterson 1997; Holmes 1996a, b; Jansen et al. 1997; Larsen and Johnson 1998; McCarthy 1993; McCreary and Tecklin 1997; Momen et al. 1994; Muick 1990, 1997; Parikh and Gale 1998; Phillips et al. 1997; Plumb and De Lasaux 1997; Rogers and Johnson 1998; Schwan et al. 1997; Standiford et al. 1997; Strong and George 1990; Swiecki et al. 1997a, b; Swiecki and Bernhardt 1998; Techlin et al. 1997.)

The key issue of the regeneration problem is that many diverse solutions have been identified and implemented (citations above). Management of oak recruitment can be and has been successful; the challenge is in facilitating large-scale implementation, particularly in collaborating with private landowners that collectively hold the vast majority of oak woodland habitat.

### Fire and oak woodlands

Fire and oak woodlands are profoundly tied together in evolutionary and ecological ways (Reich et al. 1990; Abrams 1992; Stephens 1997). Frequent, low intensity fires gave oak woodlands in and around the Central Valley their open, park-like appearance. Frequent fires acted to thin out the understory of shrubs and small trees, and thus provide less competition for soil nutrients and water among larger, established oaks. Fire suppression arrived with European settlement. Prior to European settlement, Native Americans of California had augmented natural fire regimes by setting fires, often on an annual basis, for a variety of reasons, including to facilitate an increased acorn harvest (see Biswell 1989; McCarthy 1993). Fire suppression began in earnest in California early in the 20<sup>th</sup> century (Biswell 1989). Although California has devastating fires annually, the overall effect of fire suppression has

led to widespread changes in forest and woodland structure and function (Biswell 1989, Bonnicksen 2000).

Another effect of fire suppression on oaks is the change in vegetation structure that arises as a result. For example, fire suppression has led to an increase in incense-cedar (*Calocedrus decurrens*) and white fir (*Abies concolor*) in Yosemite National Park, which in turn has reduced the density of black oaks there (Phillips et al. 1997). In northern California, fire suppression has led to increased densities and a lower elevation occurrence of Douglas-fir (*Pseudotsuga menziesii*) at the expense of white oak, which has declined in number (Barnhart et al. 1996). This scenario is also true in the Willamette Valley of Oregon (Johannessen et al. 1971).

### Over-grazing by Cattle

Over-grazing by cattle has been shown to have multiple and strong detrimental effects to ecosystems in the West (see reviews by Fleischner 1994; Belsky et al. 1999). Over-grazing has severely disrupted ecosystem structure and function generally (Fleischner 1994), and in California oak woodlands as well (Stromberg and Griffin 1996; Jackson et al. 1998; Swiecki and Bernhardt 1998). Over-grazing by cattle has directly and indirectly facilitated the invasion of weedy (European) annual grasses and the associated decline (and often loss) of native perennial grasses (Hamilton 1997). The weedy annual grasses compete for soil moisture with oak seedlings. Cattle also consume young oak shoots, as do feral pigs and native wildlife like pocket gophers and deer.

### Sudden Oak Death

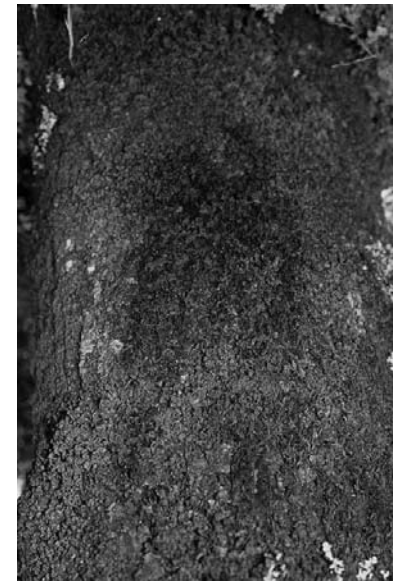
The newest threat to our California oaks emerged very dramatically in recent years. Tanoaks in Marin County were found to be dying in 1995 (Svihra 1999a,b,c). Soon, varied reports on tanoak death were noted elsewhere in the coastal forests of the Bay Area. In 1999, at a CalPIF meeting at Pfeiffer State Park in Big Sur, participants noticed the majority of tanoaks there were dead, conspicuous with their brown leaves still clinging to the trees. Soon, others noted that coast live oaks and black oaks near infected populations of tanoak were also showing similar symptoms and dying. The disease was christened as Sudden Oak Death Syndrome or SODS, and now is generally known simply as Sudden Oak Death or SOD.



Dead Tanoak

photo by Steve Zack  
Wildlife Conservation Society

In 2000, pathologist Prof. Dave Rizzo of University of California, Davis, isolated the pathogen and discovered it to be a previously unknown species of *Phytophthora* (Standiford 2000). *Phytophthora* is a fungus-like pathogen of the same genus that caused the Irish potato famine and that has been attacking Port-Orford-cedar (*Cupressus lawsoniana*) to the risk of extinction (Hansen et al. 2000, Fimrite 2000). A *Phytophthora* species has attacked Mediterranean oaks (Brasier 1996), another species has crippled alders (*Alnus* spp) in Europe (Cech 1998), another is attacking *Eucalyptus* forests in Australia (Hansen 1999), and the genus has been a serious pest to innumerable agricultural crops worldwide (Erwin and Ribeiro 1996).



Sapwood bleeding

photo by Steve Zack,  
Wildlife Conservation Soc.

The *Phytophthora* attacking California's oaks results in very distinctive symptoms. The symptoms include dark discolored patches of bark on the lower trunk, often exuding a reddish sap ("sap bleeding"), the presence of fruiting bodies of the fungus *Hypoxylon* sp., and the frass of bark and ambrosia beetles (*Coleoptera: scolytidae*). The leaves turn brown quickly (Svihra 1999a,b,c; Standiford 2000). This particular *Phytophthora*'s DNA does not match any known species, raising the possibility of it being a new pathogen through interspecific hybridization (see Brasier et al. 1999) or a new mutant form of an existing or introduced pathogen. Different *Phytophthora* spp. have been isolated from diseased oaks in California before this problem (Raabe 1990), but they have not caused anything near the widespread infestation and death that this new pathogen has. Brasier (1996) argues that global warming enhances the oak decline in southern Europe, caused by *Phytophthora cinnamomi*.

To date, valley oaks, blue oaks, and Oregon oaks show no symptoms of SOD. Thus, it seems possible that only those oaks in the "Red" group, plus *Lithocarpus* tanoaks, (Tucker 1980) are susceptible, while those of the "White" Group are immune (Table 4-1).

*Phytophthora* species are oomycetes and now placed in their own Kingdom, Chromista, with another genus (Erwin and Ribeiro 1996), and are no longer considered true fungi because of their distinctive flagella and DNA. Their zoospores are mobile in moist soil and water, which can become resting spores (oospores and chlamydospores) in drier conditions. In the case of *P. lateralis*, the agent killing Port-Orford-cedar, the spores are easily transported by vehicles between watershed on the mud of tires, and by wildlife and cattle, as well as hikers and others in the woods.

During the summer of 2000, a research team sponsored by the *Wildlife Conservation Society* investigated the geography of the SOD epidemic. *WCS* surveyed the range of tanoak for the presence or absence of symptoms. The native range of tanoak runs along coastal forests in southern Oregon, down through coastal California to just north of Santa Barbara, with isolated populations in the Klamath Mountains and in the Sierras (Tappeiner et al. 1990). The team combined roadside surveys with plot samples. Preliminary results indicated that the disease was evident over some 350 miles of California coastal forest. Subsequent pathology studies have indicated that a different *Phytophthora*, *P. illisii*, may be responsible for symptomatic trees in northern California. Then, the northern boundary of symptomatic trees was at Humboldt Redwoods State Park, just south of Eureka, and symptomatic trees of all three species were found in regular patches along coastal forests to the Santa Lucia Range north of San Simeon (Steve Zack, unpublished data). Currently (April 2002), the disease has spread to southern Oregon (although very local and patchy there) and to the Sierras (detected in Bigleaf Maples, but not yet in tanoaks or oaks there) (see the website [www.suddenoakdeath.org](http://www.suddenoakdeath.org) for updates on range and species affected by the pathogen). Preliminary results from 2000 also reveal considerable regional variation in the extent of the disease. In northern California, approximately 10 percent of the tanoaks had disease symptoms, whereas in Big Sur (Pfeiffer State Park) nearly 90 percent were dead or diseased.



Dead Coast Live Oak – Felton, California

photo by Steve Zack, Wildlife Conservation Society

Other areas particularly hard hit (ca. 40-45% of trees were symptomatic or dead) are tanoaks at Muir Woods National Monument, coast live oaks at China Camp State Park (near San Rafael), and tanoaks at Henry Cowell Redwoods State Park (in Felton). It is clear that this pathogen has spread very quickly, perhaps more quickly than other tree epidemics known in North America (Little 1995). It is not all clear if the disease is still spreading as quickly as in the late 90's or if healthy trees in infected areas are immune. Unfortunately, it seems reasonable to guess that the disease would continue to spread north, as it seems to have spread very far very fast. It would also seem that the percentage of infected trees will likely grow such that northern infected populations may become more similar to those around Marin County and at Big Sur.

The effect on wildlife of this die-off of tanoaks and oaks in coastal California is inestimable. With nearly 90% of tanoaks dead in Pfeiffer State Park in Big Sur, the loss of tanoaks to animals as diverse as black bear, deer, California Quail, and Steller's Jays, plus the several score of other species directly or indirectly dependent on acorns will be dramatic. The *Wildlife Conservation Society* is undertaking studies of wildlife effects of this pathogen in coastal California.

#### Oak Woodland Viability

The joint concerns of lack of recruitment and the new SOD epidemic dramatically affect most of the nine *Quercus* oak tree species and tanoak in California (Table 4-1). Of the ten acorn-bearing trees, seven have one or both of the problems, with black oak and coast live oak afflicted by both (Table 4-1). Solving the problem of lack of recruitment of white oaks, such as Valley oak and Blue oak, is especially important given that they appear to be unaffected by SOD, and therefore may be critical to the long-term viability of oak woodland-dependent wildlife.

The striking need for progressive management of California's oak woodlands is challenging for those concerned with oaks and wildlife. Yet, it must be recognized that 85% of oak woodlands are on private lands (Griffin and Muick 1990), and thus the capacity to manage these lands professionally and consistently varies and is challenging, to say the least. Working with private landowners is a significant challenge for conservationists (Knight 1999; Dale et al. 2000), but essential to guaranteeing a future of viable oak woodlands and wildlife in the future (Askins 2000).

Recent volumes directly concerned with the California landscape have raised concerns of oak woodland viability, particularly the recruitment problem (Barbour et al. 1993; Pavlik et al. 1991; Johnston 1994). The *Oaks of California* by Pavlik et al. (1991) is a particularly beautiful and well-designed book. Within California, a few conservation planning efforts have singled out oak woodlands, including the Nature Conservancy's ecoregional plans and the Sierra Nevada Ecosystem Project.

Surprisingly, other recent assessments of biodiversity and environmental problems make no special mention of the major problems facing California's oak woodlands, particularly the recruitment problem (Sudden Oak Death is too new). For example, a major overview of

imperiled ecosystems in the United States by Noss et al. (1995) has no significant discussion of California oaks, but cites only a 14% loss of hardwood woodlands (Bolsinger 1988), and cites the 99.9% loss of “riparian oak woodland” (those dominated by valley oak, Martin 1986). A two volume effort to assess the nation’s biological resources by the U.S. Geologic Survey (Mac et al. 1998) makes scarce mention of oak woodlands in its California section. The recent assessment of habitats and biodiversity by the *Nature Conservancy* (Stein et al. 2000) makes no particular mention of California’s oak woodlands. Likewise, a major assessment of North America produced by the *World Wildlife Fund* (Ricketts et al. 1999) emphasizes much of California’s distinctive endemic diversity, but again makes no particular mention of California’s oak woodlands.

Less attention may be given to oak woodlands than to other habitats, such as riparian or coastal sage scrub, which are inhabited by numerous species of special concern. However, oak woodlands are especially well-loved and support a large diversity of animal and plant species. Clearly, the issue of oak woodland viability still needs considerably more recognition before it can be adequately addressed.



photo by Steve Zack, Wildlife Conservation Society

**Table 4-1.** The Oak Trees (and Tanoak) of California and the presence/absence of conservation problems discussed in the text.

Common Name	Latin Name	Group <sup>1</sup>	General Distribution in California <sup>2</sup>	Recruitment Problems <sup>3</sup>	Infected by SOD <sup>4</sup>
Tanoak	<i>Lithocarpus densiflorus</i>	--	Coastal forests, spotty in Klamaths and Sierras		Yes
Black Oak	<i>Quercus kelloggii</i>	Red	Northern foothills	Occasional	
Blue Oak	<i>Quercus douglasii</i>	White	Central Valley foothills, dry coastal	Yes	Yes
Canyon Oak	<i>Quercus chrysolepis</i>	Interm.	Foothills throughout state		
Coast Live Oak	<i>Quercus agrifolia</i>	Red	Central, southern coastal forests	Yes	Yes
Engelmann Oak	<i>Quercus engelmannii</i>	White	Extreme southern, coastal CA		
Interior Live Oak	<i>Quercus wislizenii</i>	Red	More interior foothills		Yes
Island Oak	<i>Quercus tomentella</i>	Interm.	Channel, Guadalupe Islands	Yes	
Oregon Oak	<i>Quercus garryana</i>	White	N CA (coastal and Klamaths), spotty along Sierras		
Valley Oak	<i>Quercus lobata</i>	White	Central Valley, dry coastal	Yes	

Notes:

1. Taxonomic group (from Tucker 1980): Red oaks are those with pointed lobes and densely hairy inner shells of acorns, among other characteristics; White oaks have round lobes and smooth inner shells of acorns, among other characteristics; Intermediate oaks (Interm.) are just that with respect to characters.)
2. The general distribution was described from range maps of *Lithocarpus* from Lappeiner et al. 1990, and of *Quercus* in Pavlik et al. 1991.
3. If recruitment (regeneration) is problematic for oaks, as noted by studies from the literature, a “Yes” or “Occasional” is entered in the column.
4. If oaks have been observed to have symptoms of the new *Phytophthora* infection (Sudden Oak Death), a “Yes” is entered in the column.



## Chapter 5. Species-Specific Recommendations and Population Targets

The birds of California's oak woodlands share many of the same needs and threats. Large-scale conversion due to urbanization and expanding industrial agriculture continues to rapidly reduce available habitat. Human encroachment subsidizes nest predators such as raccoons, rats, and skunks and introduces exotic species of plants and animals, including domestic cats, European Starlings, and House Sparrows. These invasive bird species often out-compete native cavity-nesting birds resulting in reproductive failure and out-right extirpation of local breeding birds. Finally, the apparent problem of oak regeneration threatens the future generations of all birds reliant on oaks.

### Species-Specific Recommendations

In preparation for this conservation plan, CalPIF developed a series of species accounts on a suite of oak-associated bird species in California. Species were chosen because they represented niches and particular habitat needs, with the rationale that they represented other species with similar requirements. These detailed accounts described historical and current ranges, life history traits, habitat needs, and management concerns for each species. The accounts are available as electronic appendices to this plan at <http://www.prbo.org/calpif/>. Below are recommendations, derived from these accounts, for five of the focal species.

Although CalPIF strongly endorses the concept of multiple-species management, it recognizes that the needs of select focal and secondary species, representative of the different aspects of California's oak woodlands, may need to be specifically addressed. It also recognizes that managing for the specific requirements of some species is likely to affect, in either positive or negative ways, other species in the community. The challenge is that conservation actions must attempt to benefit multiple species while simultaneously tailoring their management activities for birds with very specific requirements.

One of the consistent issues raised with oak-associated birds is the need for further research into their habitat needs and management concerns. These recommendations need to be implemented, monitored, and altered as necessary. As this plan is a "living document," so are these recommendations. With future research, management decisions can be made that best benefit both the birds and humans using oak woodlands.

### Lark Sparrow (*Chondestes grammacus*)

#### Population:

One of California's most beautiful sparrows, the Lark Sparrow often frequents open woodlands and grasslands. It usually nests on the ground, though it makes frequent use of available shrubs for perching and foraging. Overall in North America, its population appears reduced since 1968, and some data indicate decline in California's oak-dominated foothill region and in grasslands (Sauer et al. 2000). Local extirpations may be due to habitat loss and other problems of human encroachment. Still, the Lark Sparrow continues to occupy much of its historic range.



Lark Sparrow artwork by Adriane Olmstead

#### Management:

##### Fire Management:

Managed burns that reduce the vegetative density of an area may encourage habitation by Lark Sparrows. However extremely hot fires may reduce potential nest sites and kill the native plant communities upon which this species relies. Fire suppression may allow the growth of overly dense habitat unsuitable to Lark Sparrows.

##### Brown-headed Cowbird Parasitism:

Lark Sparrows frequently host Brown-headed Cowbirds and suffer reduced productivity. Efforts to manage for cowbirds would likely benefit this species.

##### Pesticides:

Insects compose nearly 25% of the food matter consumed by this species. This species is known to nest in active agricultural areas, including row crops and orchards. Pesticide application in these areas may reduce prey availability and have other deleterious affects. More study in this area is needed.

##### Invasion of Exotic Vegetation:

In some areas, Lark Sparrows no longer breed where native vegetation has been replaced by invasive exotic grasses. Along with many other plants and animals, they would benefit from efforts to control exotics and restore native vegetation.

##### Disturbance:

Because they prefer to nest on the ground, Lark Sparrows are particularly vulnerable to such disturbance as grazing, off-trail recreation, burning, and mowing. Their nests are also

exposed more readily to predators such as domestic cats, raccoons, and dogs. Managers should take steps to limit this kind of disturbance during the breeding season (March through August).

**Research Needs:**

The Lark Sparrow's preference for edge habitats may have excluded it from many research and monitoring efforts. Few studies have focused on this species and its low densities render broad studies less effective. More studies on this species' life history, current range, and habitat requirements are needed.



Oak Titmouse  
artwork by Adrienne Olmstead

**Oak Titmouse (*Baeolophus inornatus*)**

**Population:**

Given its name, it's no surprise that this species populates many of California's oak and oak-pine woodlands. Usually preferring areas of moderate canopy cover, they nest in natural cavities or holes previously excavated by woodpeckers. While the species continues to appear in every bioregion with oaks in the state, Breeding Bird Surveys indicate a significant decline in California since 1980.

While the Oak Titmouse readily nests near human settlement, and can often seem fearless when faced with human observers, it suffers from the human related invasion of nest-competitors such as European Starlings and House Sparrows.

**Management:**

**Canopy Cover:**

The Oak Titmouse prefers woodlands with a canopy cover between 40-70%. Thinning of trees for lumber or firewood cutting may render habitat unsuitable. Land owners and managers should be encouraged to maintain stands with sufficient canopy cover for this species.

**Acorn Woodpecker (*Melanerpes formicivorus*)**

**Population:**

Of all the birds that rely upon California's oaks, the Acorn Woodpecker is the one most intimately linked to the habitat. With its distinctive clown-like face and "waka-waka" calls, it is easily detectable by most observers and hard to forget once seen. Acorn Woodpeckers breed cooperatively throughout the oak woodlands and oak-pine hillsides of California. They usually live in family groups of 2-15 individuals and cluster around a few granary trees, in which they store acorns. They readily appear on Christmas Bird Counts and Breeding Bird Surveys and can be found both near to and away from human settlements and other disturbance.



Acorn Woodpecker  
artwork by Adrienne Olmstead

The geographic distribution and density of Acorn Woodpeckers in California are significantly correlated with oak species diversity (Bock and Bock 1974, Koenig and Haydock 1999). Reproductive success and population size appear regulated by granary tree availability and the amount of acorns stored during the preceding autumn (Trail 1980; Koenig and Mumme 1987, Stacey and Ligon 1987). Population trend estimates based on Breeding Bird Surveys are inconclusive, though local extirpations due to oak removal have probably occurred and invasion by European Starlings may also pose a threat.

**Conservation and Management:**

**Acorn Harvests:**

Acorn Woodpeckers actively harvest and store acorns. Family groups collect acorns and hammer them into drilled holes in granary trees on the territory. This pantry serves to supplement their diet throughout the year, particularly in the winter months when insect prey is sparse. In Arizona, where acorn crops are light, populations do not form family groups and the birds will migrate over the winter to search for food. In California, the fate of Acorn Woodpecker family groups is often closely tied to that of their local oaks; years of low acorn production are often followed by less productive breeding seasons (Trail 1980; Koenig and Mumme 1987; Stacey and Ligon 1987). A reduction in acorn availability, through an overall reduction in oaks, may endanger local populations and groups have been forced to emigrate from an area during years of poor acorn production (Hannon et al. 1987). Managers should seek to maintain large tracts of land to include a natural diversity of oak species or intraspecific oak varieties with different seeding phenologies. This will help avoid synchronous or wide geographic-scale crop failures (Koenig and Haydock 1999).

**Granary Trees:**

Granary trees anchor Acorn Woodpeckers to a site, providing supplemental food throughout the year. Such trees are often dead or have many dead limbs, which are easier to

bore into. The soft, dead wood is also attractive to fire-wood cutters, whose activities can reduce available habitat for the woodpeckers (Koenig et al. 1995). Managers should encourage the maintenance of all trees used as granaries (trees and limbs filled with tell-tale holes for acorns), even if they are not currently in use by an Acorn Woodpecker group. On average, Acorn Woodpecker groups maintain 2.1 granary trees per 6 ha territory (range 1-7) (MacRoberts and MacRoberts 1976). Land managers should maintain a similar high density of snags and dead tree limbs, or soft-wooded live trees such as pines or sycamores (35 granary trees/100 ha, or 1 snag every 2.86 ha). Dead tree limbs or snags from 17 cm to greater than 100 cm can be used as both a granary and nest site (Hooge 1989).

#### **Grazing and Oak Recruitment:**

Damage from cattle grazing in pine-oak woodlands and montane riparian areas may threaten some populations of Acorn Woodpeckers. While Acorn Woodpeckers are still common throughout their range, the low recruitment of new oaks on intensively grazed land will likely not sustain populations in the future. For example, a lack of potential granary trees due to poor recruitment has the potential to cause eventual population declines (Ligon and Stacey 1996).

#### **Land Conversion:**

Land conversion from oak woodland to other uses, such as residential or agricultural, can affect woodpecker populations if adequate food resources are compromised. However, Acorn Woodpeckers show a strong ability to adapt to suburban and city-park development if acorns are available. They will often use utility poles and wooden structures, such as sheds and barns, as roosts and granaries (Koenig et al. 1995).

#### **European Starlings:**

Starlings often out-compete many native birds for nest cavities. While Acorn Woodpeckers will successfully defend an initiated nest, they usually fail to do so for cavities invaded before nest initiation or egg laying. Starlings are most common near human settlements and their presence can signal of habitat fragmentation. Large tracts of land, away from disturbance, should be maintained whenever possible to discourage invasion of Acorn Woodpecker territories.

#### **Structural and Species Diversity:**

Current population levels may rely upon a diverse age structure and species composition of oak trees (Ligon and Stacey 1996, Koenig and Haydock 1999). Managers can achieve structural and floristic heterogeneity through less intensive grazing methods, planting and protection of multiple species of oak seedlings (using 'tree-pees' etc.), and by creating optimal conditions for oak woodland regeneration.

#### **Western Bluebird (*Sialia mexicana*)**

##### **Population:**

Western Bluebirds are a common site on fence posts and low snags in oak woodlands and savannas throughout the state. They prefer fairly open areas, though they avoid clear cuts and agricultural fields. Breeding populations of Western Bluebirds appear to be declining in some regions of the state, primarily due to human development and subsequent invasion by European Starlings. Winter populations fluctuate with annual mistletoe crops, and may be excluded from areas where mistletoe, or the oaks it parasitizes, is cleared.



Western Bluebird photo by Ian Tait

##### **Management:**

##### **Nest box Programs:**

Recent efforts to expand nest box building programs may help curtail bluebird declines. Nest box programs should include a monitoring component which:

1. Ensures that boxes are being used by native species. Those that are not should be reviewed and perhaps removed to avoid use by unwanted species such as House Sparrows or European Starlings.
2. Ensures that predators are not regularly taking nestlings or killing adults.
3. Maintains boxes in good condition. For example, woodpeckers will enlarge holes that will allow predators, especially European Starlings and House Sparrows, to get into nest boxes and destroy nests.

You can find guidelines from the **North American Bluebird Society** on-line at <http://www.nabluebirdsociety.org/>.

##### **Logging Practices:**

The practice of "thinning" is less detrimental to bluebirds than "clearcutting." This problem is particularly relevant in areas where oaks are cleared to install vineyards or conifers (for logging). Leaving at least some oaks may mitigate these losses. Bluebirds, like many cavity nesters, require older trees with naturally occurring or previously excavated cavities. Furthermore, they prefer live trees rather than ones that have completely died.

##### **Urbanization:**

This problem extends to all animals reliant on oak woodlands. Increased urbanization leads to the introduction of nest-site competitors and predators such as House Sparrows, European Starlings, and an increase of mammals associated with urban areas (such as cats, skunks, and raccoons).



**Blue-gray Gnatcatcher (*Polioptila caerulea*)****Population:**

Blue-gray Gnatcatchers historically bred in oaks and chaparral stands throughout most of California's bioregions. Data from the past thirty years show some declines and extirpations, possibly connected with the expansion of Brown-headed Cowbirds and the heavy parasitism gnatcatchers incur. There have been no recent surveys that adequately estimate their current breeding range. Where nests have been found, nest success is extremely low and parasitism common, a characteristic shared with other gnatcatcher species, including California and Black-tailed, signaling a need to gather more conclusive information about the California population.



Blue-gray Gnatcatcher at nest photo by Ian Tait

**Management:****Brown-headed Cowbirds:**

Until recently, Blue-gray Gnatcatchers appeared extirpated from San Diego County, probably due to overwhelming parasitism pressures. Conservation efforts on behalf of the Least Bell's Vireo and California Gnatcatchers may benefit Blue-gray Gnatcatchers in the region. Monitoring of the two listed species should be extended to include Blue-grays to establish whether their population is expanding with control efforts as well.

**Diverse Habitat Structure:**

Blue-gray Gnatcatchers prefer to nest in open scrubby areas and forage in more dense vegetation. Protected and managed habitat should maintain such diverse structure, including mosaics of oaks and shrubs.

**Research and Monitoring:**

Few recent data are available for Blue-gray Gnatcatchers in California. Breeding Bird Surveys and Point Counts poorly sample populations because these birds live in relatively low densities, though they are easily recognized when found. Breeding Bird Atlas data may provide valuable insight to local population changes. However, much more detailed study is needed. The few nest studies that do include Blue-gray Gnatcatchers demonstrate an extremely low nest success rate.

**Population Targets**

Partners in Flight seeks to develop avian population targets that will guide conservation efforts and provide land managers with a gauge of success for their restoration and management activities. Although ambiguous and hard to develop, numerical population targets provide a compelling means of communicating with the public and policy makers. In some cases, targets may simply require maintenance of populations at existing levels. However, targets for rare or declining species will encourage actions that increase existing populations to sustainable levels.

Bioregionally-based population targets for many of the primary and secondary oak woodland species have been developed using all available data (Table 5-1). These targets are simply the highest densities (either indirectly through point counts, or directly through spot mapping) found for that species within a given bioregion. These data are currently lacking from most bioregions and for many species. More data likely exist for some of these species, and contributions of data to CalPIF is encouraged for incorporation into future versions of this "living" document.

Two types of data are presented. The first is spot map data, in which the number of territories per 40 hectares is estimated based on Breeding Bird Census plots (plots are usually less than 40 hectares, but are converted for purposes of standardization). The second is point count data, in which the average number of individuals detected within 50 meters of a point count station is presented. These two types of data are not necessarily comparable to one another, nor convertible. Such reference density estimates are useful as population density targets that can translate into habitat acreage protection for some species, or be considered in restoration goals.

**Table 5-1.** Suggested population targets by species and bioregion<sup>1</sup>. See Table 5-2 for a key to data sources, indicated here by superscripts <sup>A,K</sup>.

Species	Bay-Delta		South Coast		Sierra		San Joaquin		Central Coast	
	Point Count <sup>A</sup>	Spot Map	Point Count <sup>C</sup>	Spot Map <sup>C</sup>	Point Count <sup>D</sup>	Spot Map <sup>D</sup>	Point Count	Spot Map	Point Count	Spot Map
Acorn Woodpecker	0.16	-	-	-	0.56	7.0 <sup>B</sup>	-	-	-	6.7 <sup>B</sup>
Ash-throated Flycatcher	0.12	-	-	10	0.31	10.6 <sup>B</sup>	-	-	-	8.2 <sup>H</sup>
Bewick's Wren	0.46	-	-	2.5	0.23	9.2 <sup>F</sup>	-	-	-	23.3 <sup>H</sup>
Blue-gray Gnatcatcher	0.10	-	-	2.5	0.27	10.0 <sup>A</sup>	-	-	-	23.3 <sup>H</sup>
Hutton's Vireo	0.19	15.6 <sup>B</sup>	-	7.5	0.01	1.4 <sup>B</sup>	-	-	-	3.3 <sup>I</sup>
Lark Sparrow	-	-	-	-	0.39	0.5 <sup>B</sup>	-	-	-	2.3 <sup>I</sup>
Lewis' Woodpecker	-	-	0	0	-	- <sup>3</sup>	?	?	-	-
Nuttall's Woodpecker	-	-	-	-	0.09	1.6 <sup>E</sup>	-	-	-	2.3 <sup>H</sup>
Oak Titmouse	0.40	15.4 <sup>F</sup>	-	3.5	1.33	26.4 <sup>E</sup>	-	-	-	49.4 <sup>I</sup>
Western Bluebird	-	-	-	-	0.38	5.0 <sup>A</sup>	-	-	-	8.2 <sup>H</sup>
Western Scrub-Jay <sup>2</sup>	0.61	-	-	-	0.31	10.9 <sup>I</sup>	-	-	-	7.0 <sup>I</sup>
White-breasted Nuthatch	-	-	-	-	0.82	4.3 <sup>B</sup>	-	-	-	10.2 <sup>I</sup>
Yellow-billed Magpie	-	-	0	0	-	-	-	-	-	-

<sup>1</sup>Numbers provided from point counts are the average number of detections within 50 meters ( $n$  / # points / # visits) of the observer during five minute counts during the breeding season. Point count data provide an index of abundance, generally thought to be conservative. Numbers from spot mapping are pairs per 40 hectares during the breeding season, unless otherwise noted. *Reference populations are cited and may not be representative of healthy populations.* Dashes represent no data and zeroes indicate the species probably never bred in that bioregion.

<sup>2</sup>Not an appropriate species to set population targets according to high counts/ high breeding densities, due to implications for other species.

<sup>3</sup>No Lewis' Woodpeckers have been found nesting at San Joaquin Experimental Range<sup>4,F</sup> during a long-term nest searching effort, although they are abundant winter residents (K. Purcell, personal communication).

**Table 5-1 (cont.)<sup>1</sup>**

Species	Klamath <sup>3</sup>		Sacramento Valley		Modoc		Mojave		Colorado Desert	
	Point Count <sup>I</sup>	Spot Map	Point Count <sup>I</sup>	Spot Map <sup>K</sup>	Point Count	Spot Map	Point Count	Spot Map	Point Count	Spot Map
Acorn Woodpecker	0.04	-	0.20	3.75	-	-	0	0	0	0
Ash-throated Flycatcher	-	-	0.49	8.75	-	-	-	-	-	-
Bewick's Wren	-	-	-	12.5	-	-	-	-	-	-
Blue-gray Gnatcatcher	0.16	-	-	2.5	-	-	-	-	-	-
Hutton's Vireo	-	-	-	-	-	-	0	0	0	0
Lark Sparrow	0.15	-	0.03	-	-	-	-	-	-	-
Lewis' Woodpecker	-	-	?	?	-	-	0	0	0	0
Nuttall's Woodpecker	-	-	0.12	5	-	-	-	-	-	-
Oak Titmouse	0.19	-	1.5	20	-	-	0	0	0	0
Western Bluebird	0.10	-	-	-	-	-	-	-	?	?
Western Scrub-Jay <sup>2</sup>	0.03	-	0.65	5	-	-	-	-	?	?
White-breasted Nuthatch	0.10	-	0.33	-	-	-	-	-	-	-
Yellow-billed Magpie	0	0	-	-	0	0	0	0	0	0

<sup>1</sup>Numbers provided from point counts are the average number of detections within 50 meters ( $n$  / points / # visits) of the observer during five minute counts during the breeding season. Point count data provide an index of abundance, generally thought to be conservative. Numbers from spot mapping are pairs per 40 hectares during the breeding season. *Reference populations are cited and may not be representative of healthy populations.* Dashes represent no data, and zeroes indicate the species probably never bred in that bioregion.

<sup>2</sup>Not an appropriate species to set population targets according to high counts/ high breeding densities, due to implications for other species.

<sup>3</sup>Additional data on territory densities can be found in Wilson et al. 1991 for Mendocino County.

**Table 5-2.** Sources of population data in Table 5-1.

Alpha code	Data source, habitat type, location, and year.
A	PRBO unpublished data. Bay-Delta data are from Marin Co. (Holmes et al. 1998) except for Oak Titmouse, which are from the Cosumnes River Preserve, Sacramento Co. Sierra data are from Independence Creek, mixed black oak and riparian habitat (1999 for Blue-gray Gnatcatchers, 2000 for Western Bluebird).
B	Van Fleet 1919; live oak woodland.
C	May and Peters 1979; coast live and Engelmann oak woodlands, Orange Co., 1978.
D	PRBO unpublished data; Tehama Co. foothills, 2001.
E	Verner et al. 1997; grazed oak woodland, San Joaquin Experimental Range, Madera co., averaged over nine years (1985-1993).
F	Verner et al. 1997; ungrazed oak woodland, San Joaquin Experimental Range, Madera co., averaged over nine years (1985-1993).
G	MacRoberts and MacRoberts 1976; Hastings Reservation, Monterey Co., territory density based on average territory size of 6 ha (average number of adults per territory = 4.4; Koenig et al. 1995).
H	Williams 1979, 1980, Joste 1981; blue oak woodlands, Monterey Co., averaged over three years 1978-1980.
I	Tietje et al. 1997b, Camp Roberts, San Luis Obispo Co., averaged over two years (1994-1995).
J	PRBO unpublished data. Klamath data are from Brewer's Oak forests in the Mendocino National Forest, Mendocino Co (1996); Sacramento Valley data are from blue oak forests at East Park Reservoir, Colusa Co.
K	Gaines 1979; blue and interior live oak woodlands, Sutter Co.
L	Cicero 2000; San Francisco Bay region, based on average territory size of 2.6 ha.



## Chapter 6. Bioregional Conservation Objectives

California has a higher biodiversity of wildlife and plants than any comparable area in the northern temperate zone (Biosystems Analysis 1994). The state also has more endemic species, particularly plants and birds, than any other state except Hawaii. This great diversity provides significant challenges in conservation planning, particularly over a state as large and geographically diverse as California.

As with the other habitat plans, we have adopted the California Biodiversity Council's 10 bioregions as a guideline for dividing the geography of California into natural communities organized by biota, climate, topography and soils (RAC 1998). See Figure 3.1 for bioregion boundaries. These contrast slightly with the 11 discrete regions recognized by Sawyer and Keeler-Wolf (1995) and Biosystems Analysis (1994).

Setting conservation goals by bioregion helps facilitate planning site-specific projects in a broader context, and provides a similar framework to other conservation planning efforts. Setting and achieving conservation goals by bioregion will:

- Ensure that a suite of ecological communities representative of California's diversity will be conserved throughout the state.
- Ensure that the broadest range of biodiversity and locally adapted races of species will be conserved.
- Facilitate action at the local level.

This section introduces each of the 10 bioregions considered in this plan. These descriptions are offered as an overview; the issues and needs may vary depending on particular sites within a bioregion. For more information on each, please consult the Resource Agency of California's *Preserving California's Natural Heritage* (RAC 1998).

For each bioregion, we list potential "Portfolio Sites", areas that are distinguished by their protected status and potential for managing oak woodland habitat through restoration. Many of these Portfolio Sites contain oak woodland habitat located near other habitats of concern. Thus, there is considerable potential for management of such areas to achieve goals for the many CalPIF habitat plans. This list is not comprehensive and will be updated as the Plan is revised. These sites have been identified by our own experience in oak woodland habitat and by drawing from the excellent volume by Pavlik et al. (1991). We ask that individuals and groups working in these bioregions bring important sites and activities to our attention.

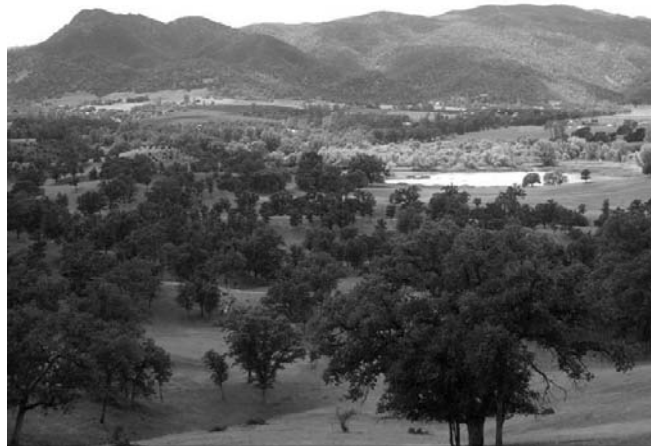
It is important to make a distinction between our use of the term "Portfolio Site" and its use by other organizations. Most notably, The Nature Conservancy of California has identified a list of sites which are prime candidates for conservation and which are ranked in order of priority based on their biological richness and the immediacy of threats to them. Some of these sites are also considered as Portfolio Sites in this and other CalPIF Bird Conservation Plans, and more may be included in the future as they become protected and efforts to manage for oak woodland are expanded.

**Sacramento Valley**

The northern portion of the Central Valley, the Sacramento Valley is a region characterized by hot, dry summers, and cool, foggy winters. The great Central Valley of California is a region that has undergone considerable transformation in the past century, from a mosaic of wetlands, riparian forests and dry grasslands containing millions of waterfowl, elk, pronghorn and other wildlife (an “American Serengeti”), to a virtual agricultural machine. Nonetheless, in the uplands that surround the valley floor and in localized bottomlands there remain several areas important to oak woodland habitat. These upland areas are among the many regions in California where conversion of habitat to vineyards poses a serious threat to oak woodlands. The lowland areas include areas that are or historically were valley oak woodland and have been degraded or reduced through development, agriculture, and the damming of California’s rivers.

**Portfolio Sites**

**East Park** is a Bureau of Reclamation (BOR) site of oak woodland and riparian habitat surrounding the East Park Reservoir, in the foothills of the Coast Range near the town of Maxwell. Extensive blue oak woodland is found here along with few, but large, valley oaks. BOR is interested in managing this area for wildlife. There is good potential for management beneficial to oak woodland habitat, which would be crucial for supporting recruitment in both valley and blue oaks.



East Park, Sacramento Valley Portfolio Site

photo by Geoff Geupel, PRBO

**Bidwell Park** has many acres for valley oak (2,250 acres) woodland in Northern California. The ownership is the City of Chico, Parks and Recreation, and it is the second largest municipal park in the country.

**The Sacramento River** region now includes areas under intensive restoration. Efforts are underway to re-establish valley oak (Alpert et al. 1999). Partners include the Nature Conservancy, the U.S. Fish and Wildlife Service, the California Department of Fish and Game, and the California Wildlife Conservation Board and stakeholders participating in the Sacramento River Conservation Area. This area is also a Portfolio site in the Riparian Bird Conservation Plan.

**Cache Creek** is an important area in northern California with large stands of both valley and blue oak. This land is administered by BLM, and has potential for restoration of recruitment and regeneration of these imperiled trees.

**San Joaquin Valley**

Also a major part of California’s Central Valley, the San Joaquin Valley has been thoroughly transformed by intensive agriculture and development. Another industry important to the region’s economy has been oil. The region is characterized by similar weather to the Sacramento Valley, including hot, dry summers and cool, foggy winters. Along with the rest of the wetlands, native grasslands and riparian vegetation, the valley oak riparian forests once characteristic of this region are almost gone (Bolsinger 1988). The water flow and habitat along the San Joaquin River itself, for instance, has been significantly diminished by the development of agriculture or mining along nearly every mile of its reach and by the construction of the Friant Dam (RHJV 2000). Nonetheless, crucial remnant pockets of valley oaks remain. Additionally, some upland areas containing oak woodland habitats exist in the foothills of the surrounding mountain ranges, including regions where conversion to wine vineyards has occurred or continues.



San Joaquin Valley

photo by Geoff Geupel, PRBO

### Portfolio Sites

**Kaweah Oaks Preserve** has one of the last valley oak riparian forests remaining in the region. This 324-acre preserve, owned originally by The Nature Conservancy and now by the Sierra Los Tulares Land Trust, is a private wildlife sanctuary created for the purpose of protecting valley oaks and associated wildlife. Valley oak regeneration has taken place (as well as many other native vegetation changes) since cattle were removed.

**Caswell Memorial State Park** also protects one of the last remnant valley oak riparian forests in the San Joaquin Valley. These 258 acres located northwest of Modesto have been owned and managed by the California state parks system since the 1950's. CalPIF and other organizations have documented the high use and clear importance of this small park to birds.

**Oak Grove Regional Park** is the site of a cattle ranch where valley oaks were retained (Pavlik et al. 1991). Today, this 170-acre park located near the city of Stockton is managed by the San Joaquin County Department of Parks and Recreation.

### Modoc

Of all the California bioregions, perhaps Modoc most resembles its historic state. It is host to the least number of human inhabitants of all ten bioregions, but continued human growth is likely as pressures increase along with California's population expansion. The landscape is characterized by extensively forested mountains, vast reaches of high desert, and volcanic uplands. Typical weather includes hot dry summers and cold, wet winters, with snow at higher altitudes. Oak woodlands are sparse and few, with black oak most common and Oregon oak also present. As in other montane habitats, changes in the fire cycle, due to fire suppression and increased fuel accumulation, has had an impact on the structure and ecology of hardwood forests in this bioregion.

### Portfolio Sites

**Quail Spring** is identified as an area where black oak co-occurs in mixed conifer stands (Pavlik et al. 1991). It is located east of MacArthur on Highway 299 and managed by the Modoc National Forest.

### Klamath

The Klamath region is home to some of the most dramatic geologic landscapes on earth. It is known for its steep, rocky shorelines, rich coniferous forests of coast redwoods and Douglas firs, extensive mountain ranges and salmon runs. No other bioregion in California receives as much rainfall, and the bioregion is characterized by cool, foggy summers along the coast and rainy winters throughout. Its high mountains create a dramatic rain shadow, resulting in stark contrast between the north coast climate and the nearby interior. Ranges in this mountainous region include the Klamath, Siskiyou, Marble, Salmon, Trinity, and Cascade Mountains, and the North Coast Range.

The bioregion is home to five national forests, the Siskiyou, Six Rivers, Klamath, Shasta-Trinity, and Mendocino. Also in this region is Redwood National Park, a network of state parks and wilderness areas, Jackson State Forest, as well as forests on private land (such as the well-known Headwaters redwood forest in Humboldt County). Although the region has received much attention for its ancient redwood forests, some areas also contain extensive tanoak forests. The northernmost detection of tanoaks infected with Sudden Oak Death (SOD) were found in the Klamath bioregion.

### Portfolio Sites

**Redwood National Park** is known for redwoods, of course, but also contains extensive tanoak forests. To date these tanoaks are not infected with the pathogen causing Sudden Oak Death (SOD). Oregon oak, black oak, and canyon oak occur on the drier slopes and bottomlands.

**Humboldt Redwoods State Park** also contains stands of tanoaks. This was the furthest north location that SOD was detected in 2000, with 11% of the tanoaks infected.

**Hopland Field Station** on the Russian River is engaged in active efforts at oak regeneration (Pavlik et al. 1991). This University of California field station is a site of active research on oak woodland issues (see Merenlender and Crawford 1998; Merenlender et al. 1998).

**McLaughlin Reserve** is a recent addition to the UC Davis Natural Reserve System and is located in the inner North Coast Range, at the junction of Napa, Lake and Yolo Counties, on land owned by the Homestake Mining Company. The 2,800 ha (7,050 acre) site, of which 20 % is oak woodland, is in transition: the Homestake gold mine is in its last phases of operation, and the McLaughlin Reserve is beginning to be used for teaching and research. It is surrounded by some 30,000 hectares (75,000 acres) of land managed by the US Bureau of Land Management (BLM).

**The Northern California Coast Range Preserve** is an immense region (7,800 acres) managed jointly by The Nature Conservancy and the University of California. Oak habitats include tanoak, black oak, Oregon oak and others. SOD infection occurs in populations of tanoak and black oak. If SOD continues to expand, this region would be important in understanding how to manage the acorn production of other oak species as tanoaks and black oaks decline.

### Central Coast

California's Central Coast is characterized by a mild climate, beautiful coastline, small mountain ranges that roughly parallel the coastline, and a wide variety of habitat types. The favorable climate in this region supports a robust agricultural industry that includes vineyards, row crops and grazing.

In recent years, the Central Coast has undergone a dramatic population increase, fueled largely by prosperous industries such as Silicon Valley's booming computer industry. This sudden and expansive growth threatens the region's habitats through land conversion, water

diversion, logging, resource extraction, grazing, and habitat clearing. Some of the worst effects of SOD are visible on the coastal forests in this region, predominantly affecting tanoak and coast live oak, and occasionally black oak.

#### Portfolio Sites

**Hunter-Liggett Military Reservation** is an extensive area where considerable research has been conducted on oak woodland ecology and prescribed fires (Tietje et al. 1997). This reservation may be an important area for various management ideas on the SOD epidemic and other oak woodland issues to be implemented and explored.

**Pfeiffer Big Sur State Park** contains 800 acres of oaks and other forested habitats. Of all the sites monitored in 2000, this was one of the hardest hit by SOD. Nearly 90% of tanoaks and more than half of other oak species (coast live oak, interior live oak and black oak) were dead or dying. Understanding how the acorn-dependent bird community copes with such devastation over the next few years will be crucial.



Hunter-Liggett Military Reservation photo by Sandy Scoggin, PRBO

**Henry Cowell Redwood State Park** is located within the Santa Cruz Mountains and is home to a number of forest habitats, including tanoak, coast live oak, redwood, ponderosa pine, madrone and Douglas-fir. It is another area hit particularly hard by SOD. Some 47% of the tanoaks here were dead or dying in 2000.

**Hastings Natural History Reservation** is located in the foothills of the Santa Lucia Mountains in Monterey County. Its 2000 acres are administered by the Museum of Vertebrate Zoology at the University of California, Berkeley as part of the UC Natural Reserve System. Oak woodlands dominate the landscape, including valley and blue oak hillsides as well as live oak and mixed hardwood forests. The reserve is a biological field station containing numerous long-term data sets pertaining to the natural history and population biology of native species in these oak woodland habitats. It is a prime area for conducting research on the region's wildlife and ecology. Bird data sets it is renowned for include the long-term study of Acorn Woodpeckers and of Western Bluebirds.

**Sedgewick Reserve** is a UC Natural Reserve administered by UC Santa Barbara. Encompassing 2,382 hectares (5,883 acres) in the Santa Ynez Valley, the reserve includes

several types of oak woodland habitats: coast live oak forest, blue oak woodland, and valley oak savannah. The site is home to several studies on oak ecology and the factors influencing oak regeneration.

#### Bay-Delta

The Bay Area-Delta Bioregion includes the San Francisco Bay area and spreads eastward to encompass the sprawling Sacramento-San Joaquin River Delta. The climate is relatively mild, with fog on the coast, warm summers inland, and wet winters. The pressure for development in this very populous region is high. This area is host to a great variety of habitat types and associated avifauna. In fact few areas in the country have such a mix of dense population centers amongst a fairly diverse wildlife setting. It is in this region that SOD was first discovered in 1995. The vineyard industry is also booming in this region.

#### Portfolio Sites

**Marin Municipal Water District** is an area containing many habitats, including tanoaks, black oaks and coast live oaks. Many of these forests are also infected with SOD. Because the Point Reyes Bird Observatory conducted extensive point counts in the watershed before the emergence of SOD in this region, there is a unique opportunity for evaluating the effect on the bird community of this epidemic as it progresses, particularly those species dependent on acorns. Researchers from the University of California (Don Dahlsten and Bill Tietje) are also studying the impact of SOD on birds and other small vertebrates in this area.

**Point Reyes National Seashore and the Golden Gate National Recreation Area** are also areas in Marin County that are host to very diverse habitats, including those where oaks are present or predominant. These lands are owned and managed by the National Park Service. Many of these forests are also infected with SOD. The Point Reyes Bird Observatory also conducted extensive point counts in all habitat types within these parks before the emergence of SOD in this region.

**China Camp State Park**, located on the San Pablo and San Francisco Bays, is another site of extensive research on the new SOD problem. Coast live oak and black oak are dead and dying here. Valley oak nearby is, to date, unaffected.

**Cosumnes River Preserve** contains one of the finest stands of valley oak forests remaining in the Central Valley. This nature preserve is cooperatively owned and managed by The Nature Conservancy, Ducks Unlimited, U.S. Bureau of Land Management, California Department of Fish and Game, Department of Water Resources, and Sacramento County Department of Parks and Recreation. An ambitious regeneration project has been implemented (Pavlik et al. 1991).

The **Mount Hamilton** Region is an extensive open space in the central Diablo coastal range south and east of San Jose. The area contains extensive public lands, including the

**Sunol Regional Wilderness** and the **Henry Coe State Park**. The Nature Conservancy is building on this basis by securing the permanent protection of key private properties that surround and connect the public lands. This provides a rare opportunity to manage for oak woodland viability on a landscape scale.

#### **South Coast**

The South Coast Bioregion includes miles of sandy beaches and steep cliffs along the coast, small mountain ranges, and extensive conifer and scrub habitats. The climate is arid and warm throughout the year. The human population is very large and continues to expand rapidly, converting and fragmenting native landscapes at an alarming rate. Much land falls under the jurisdiction of forest service (Angeles, Los Padres, Cleveland, and San Bernardino National Forests), state and local parks, state beaches, and federal wilderness, recreation areas and wildlife areas. The Channel Islands off the coast of Los Angeles contain several endangered endemic species of California, including island oak. Island oak is the rarest of all oak tree species in California.

#### **Portfolio Sites**

**Santa Cruz Island Preserve**, managed by The Nature Conservancy, contains numerous stands of island oak and at least seven other oak species (Pavlik et al. 1991). The ongoing removal of feral ungulates (goats, sheep, and pigs) will hopefully provide opportunities to manage and restore regeneration in this key species.

**Santa Rosa Plateau Ecological Reserve**, a 8,300 acre Nature Conservancy property in Riverside County, is an important reserve for Engelmann Oak savannah habitat.

The **Nature Reserve of Orange County**, although perhaps better known for its coastal sage scrub habitat, also contains oak woodlands and is the site of a demographic bird monitoring project. This 38,000-acre reserve combines 21,000 acres of Irvine Company land with 17,000 acres of county and state parks, as well as other public and private lands

#### **Mojave and Colorado Desert**

These regions are dominated by the expansive deserts of southeastern California. Climate is characterized by hot, dry summers and fairly cold winters. Few people inhabit this bioregion, but it is already growing as population pressures in the rest of the state increase. Oak woodland is very sparse in these regions (less than a 10<sup>th</sup> of a percent of the total area) but small pockets do exist, including blue oak woodland, oak/pine foothill, and black oak habitats.

#### **Sierra**

The Sierra Bioregion spans a vast and mountainous area, characterized primarily by the extensive and rugged Sierra Mountains and the arid eastern portion of the state. It is a region rich in biodiversity, containing over half the plant species found in California and more than 400 of the state's terrestrial wildlife species (RAC 1998). Evidence suggests that many of the region's more common birds may be in decline (Siegel and DeSante 1999). In the montane regions this area is the key domain for black oak in California, and blue oak

woodland and blue oak/ foothill pine habitats are found in the foothills. The booming vineyard industry certainly extends into and threatens these blue oak habitats of the Sierra Bioregion. While almost all of the blue oak woodlands in this region are on private land (SNF 2000), the majority of the Sierra Bioregion lands are managed by public agencies, and much of the black oak forests are in national forests. Resource managers and landowners appear willing to invest time and money into finding more ecologically sound management practices and are incorporating conservation recommendations into work plans and project goals (Siegel and DeSante 1999, SNF 2000).

An extensive review of the conservation needs and recommendations for much of this region has been provided in the Avian Conservation Plan for the Sierra Nevada Bioregion (Siegel and DeSante 1999), the Sierra Nevada Ecosystem Project (Davis and Stoms 1996), and the Sierra Nevada Framework (SNF 2000). The Sierra Nevada Framework summarizes the history, ecology and conservation issues in Sierran oak (and other) habitats, and recommends management alternatives to be implemented in national forests of this region ([www.r5.fs.fed.us/snctf](http://www.r5.fs.fed.us/snctf)).

#### **Portfolio Sites**

**San Joaquin Experimental Range** is a USDA Forest Service research facility located in the foothills of Madera county. The oldest rangeland research station in California, its 1875 hectares (4600 acres) consist of blue oak/ foothill pine woodlands and annual grasslands. The site has a long history of research and education on oak ecology, wildlife, range management, water quality, and other aspects of the ecosystem. It also contains one of the longest-running bird monitoring efforts in California oak woodlands (Verner et al 1997, Purcell et al. in press). Currently SJER is managed by California State University Fresno, under a long-term agreement with the USDA Forest Service, Pacific Southwest Research Station.

**Yosemite Valley**, in Yosemite National Park, is undergoing extensive restoration of once-extensive black oak woodlands (Pavlik et al. 1991).

The **Lassen Foothills** region is an extensive area of grasslands and Blue Oak woodlands. The Nature Conservancy is working to protect this area from fragmentation by promoting conservation easements and acquiring land. Two preserves here run demonstration projects that include habitat restoration, rotational grazing, prescribed burning, and other range management techniques with potential to benefit oak woodlands.



## Chapter 7. Implementation of Conservation Plan Recommendations

An implementation strategy for the Oak Woodland Bird Conservation Plan is in development. It will include the engagement of local, bioregional conservation efforts to better define bioregional priorities for acquisition, restoration, and focused conservation efforts. The implementation process will eventually include a series of local workshops to:

- Familiarize local organizations with the Conservation Plan and the Implementation Plan
- Identify local initiatives, projects, and organizations capable of working as local partners to achieve habitat, restoration, and population targets.
- Develop conservation and restoration acreage objectives based on inventory, assessment and biological need.

### The North American Bird Conservation Initiative

In 1998, participants at a meeting of the International Association of Fish and Wildlife Agencies developed a vision to link all of the major bird conservation initiatives in Canada, the U.S. and Mexico (CEC 1998).

The participants represented each of the four major bird conservation initiatives already underway on the continent: The North American Waterfowl Management Plan (the oldest and most successful of bird conservation initiatives), Partners in Flight, the Shorebird Conservation Plan, and the Colonial Waterbird Conservation Plan. This new overarching program, known as the North American All Bird Conservation Initiative (NABCI), seeks to synthesize the efforts of all these groups by creating “regionally based, biologically driven, landscape-oriented partnerships delivering the full spectrum of bird conservation across the entirety of the North American continent, including simultaneous, on-the-ground delivery of conservation for both game and nongame birds.” See [www.nabci-us.org](http://www.nabci-us.org) for more information.

State, provincial, federal and non-governmental representatives from Canada, Mexico, and the U.S. adopted an ecological framework that facilitates coordinated conservation planning,



Yellow-billed Magpie  
artwork by Adrienne Olmstead

implementation, and evaluation among major bird initiatives. These Bird Conservation Regions (BCRs) were defined by adopting the hierarchical framework of nested ecological units delineated by the Commission for Environmental Cooperation (CEC).

Existing joint ventures as formed under the North American Waterfowl Management Plan (NAWMP) are recognized as important vehicles for local and regional delivery of bird conservation goals. Joint venture focus areas do not always correspond with BCR boundaries, but joint ventures are coordinating with the BCRs encompassed within their boundaries. Many joint ventures in North America have embraced the concept of “all-bird” conservation.

California is encompassed within five BCRs: the Northwestern Pacific Rainforest region, the Sierra Nevada region, the Coastal California region (which includes the Central Valley), the Great Basin region, and the Sonoran and Mohave Deserts region. The state currently hosts five Joint Ventures: the Central Valley Habitat Joint Venture, the San Francisco Bay Joint Venture, and the Riparian Habitat Joint Venture (all located entirely within the state), and the Intermountain West Joint Venture and the Pacific Coast Joint Venture (both located partially within the state). Future bird conservation in priority habitats of California will be achieved by encouraging adoption of the all-bird conservation concept within existing joint ventures of the North American Waterfowl Management Plan and/or by expansion of the Riparian Habitat Joint Venture to include other habitat types.

The following is only a partial list of programs and agencies with which CalPIF intends to interface in implementing this plan:

#### *Non-governmental Organizations:*

American Farmland Trust  
California Oak Foundation  
California Native Grass Association  
California Native Plant Society  
California Farm Bureau Federation  
Cosumnes River Project  
California Cattleman's Association  
Solano Farmlands and Open Space Foundation  
Point Reyes Bird Observatory  
Wildlife Conservation Society  
National Audubon Society  
National Fish and Wildlife Foundation  
The Nature Conservancy  
Wildlife Conservation Society

#### *Private Organizations:*

Hedgerow Farms  
California North Coast Grape Growers Association  
Wine Institute  
Napa Valley Vintners Association  
Sonoma County Vintners and Growers Association  
Carneros Quality Alliance



Certified Rangeland Managers  
Registered Professional Foresters

*University Organizations:*

University of California Integrated Hardwood Range Management Program  
University of California Cooperative Extension (UC-Berkeley, UC-Davis)

*State of California Organizations:*

California Department of Fish and Game  
California Department of Forestry and Fire Protection  
Sonoma County Agricultural Preservation and Open Space District  
Resource Conservation Districts (many occurring in the range of oak woodlands)  
State Park System in California  
Wildlife Conservation Board

*Federal Organizations:*

USDA Forest Service  
US Fish and Wildlife Service  
Bureau of Land Management  
Natural Resource Conservation Service  
Bureau of Reclamation



## Chapter 8. Conservation Action Recommendations

Specific recommendations for conservation action are offered here. Each recommendation is accompanied by a brief discussion of the scientific evidence that supports it. These recommendations cover actions in several areas:

- habitat protection and restoration
- land management
- monitoring and research
- policy

Many of these recommendations follow those made by other organizations, or complement them. The goal of these recommended actions is to facilitate the protection and restoration of oak woodland habitat, including the successful recruitment of new oaks for future generations of the wildlife that depend on them. Only by restoring the processes involved in oak regeneration can oak woodland birds be secured a future, and thus avoid their listing as threatened or endangered species. Likewise, restoring oak regeneration will contribute to preserving sustainable working landscapes. It is our hope that these recommendations will help galvanize and guide the programs of conservation organizations, expenditures of government agencies, and the actions of private and public land managers.

Most recommendations are supported by the most recent scientific data and analysis available and a synthesis of ecological literature on oak woodlands. Additionally, recommendations were derived from focal species accounts (see <http://www.prbo.org/calpif/>). Some recommendations are, as of yet, poorly supported by data, but can be evaluated through biological research, monitoring, and adaptive management. This process will allow the continuing refinement of these recommendations and the development of more effective management and restoration strategies.

### Habitat Protection Recommendations

#### **OBJECTIVE 1**

*Prioritize oak woodland sites for protection.*

#### **Recommendations**

##### **1.1. Prioritize sites with intact oak regeneration and decay processes.**

One of the greatest threats to oak woodland habitat in California is the lack of oak regeneration, specifically in blue, interior live, Oregon white, and valley oak communities. Habitats that presently harbor healthy bird populations will fail to support future generations of oak woodland-associated bird species if regenerative processes are not intact.

Regeneration may be considered to be adequate if the number of seedling and sapling oaks is sufficient to offset mortality (Standiford and Tinnin 1996). Oak recruitment may be episodic, and therefore sites that currently lack young oaks may still be viable in the future. However, prioritizing sites that are presently demonstrating healthy oak regeneration constitutes a step towards insuring viable habitat for future bird populations.

Other important parts of an ecologically functioning oak woodland system are acorn production and oak tree decay. Four oak woodland-associated species, Acorn Woodpecker, Yellow-billed Magpie, White-breasted Nuthatch and Western Scrub-Jay, depend on acorn production as a food source and in turn, are instrumental in the dispersal process needed for oak regeneration. Ten of the oak woodland-associated focal species depend on decaying trees and limbs for nest cavities and also, in the case of Acorn Woodpecker, Oak Titmouse and White-breasted Nuthatch, for storing food.

#### 1.2. Prioritize sites according to current indicators of avian population health.

Conservation efforts should use the most recent information regarding the present quality of habitat and wildlife populations to prioritize the acquisition and protection of sites. Although it is unknown whether demographic bird monitoring data can predict the regenerative potential of oak woodland habitats, they do provide a means to prioritize habitat quality in its present condition.

#### 1.3. Prioritize sites to include diverse age structure of oak trees, especially large old oak trees.

Protecting sites with a diverse age structure of oak trees will provide a continuum of seeding phenologies, preventing synchronous or wide-scale acorn crop failures. Maintaining large old oaks within a diverse age structure will provide decaying limbs necessary for bird nesting sites in addition to high output acorn production. McDonald (1990) demonstrated that Black Oaks much reach 30 years before producing viable acorns and seldom produce large quantities of acorns until they reach 80-100 years. Good acorn producing trees can continue abundant production up to 200 years.

Territorial requirements for the Acorn Woodpecker, a species instrumental in acorn dispersal, include large central trees for nesting, granary and roosting, surrounded by a periphery of smaller or medium sized trees.

#### 1.4. Prioritize sites to represent a diversity of oak woodland types.

The full range of variation in oak woodland habitat types (and associated animal species) can be protected by: 1) protecting a diverse portfolio of sites located in different parts of the geographic and elevation range of oak woodlands, and 2) protecting individual sites that contain a variety of oak woodland types. Protecting the variety of oak woodland types may help protect the various birds that are associated with different types of oak woodland habitats. For example, Lark Sparrows are likely to be found more often in open, savanna-like oak habitats (Small 1994), while Dark-eyed Juncos may be more abundant in denser

woodlands with a thick understory (Tietje et al. 1997). Some bird species also appear to occur in higher numbers when the diversity of oak woodland types present in the surrounding landscape is higher (Stralberg and Williams, 2002).

#### 1.5. Prioritize sites according to surrounding land use.

Certain uses of land adjacent to oak woodland habitat may negatively impact the quality of that habitat for native birds. For example, oak woodlands that are adjacent to pastures or residential developments may be more accessible to European Starlings, which compete for nest cavities with other secondary cavity nesters (Verner et al. 1997, Merenlender et al. 1998). Urban or suburban development may also have a negative effect on the presence or abundance of some bird species, including Lark Sparrow and Rufous-crowned Sparrow, in adjacent oak woodlands (Stralberg and Williams, 2002).

#### 1.6. Prioritize oak woodland sites adjacent to intact chaparral, grassland, pine or and riparian habitats.

Riparian areas are especially important to many species of birds and other wildlife that are also found in adjacent oak woodlands (RHJV 2000). An analysis using the California Wildlife Habitat relationships System (CWHRS) predicted that 150 species of birds use riparian habitat within or adjacent to oak woodlands for breeding, feeding and/or cover (see Chapter 4 in Standiford and Tinnin 1996). Many birds that are more typical of chaparral or grassland habitats can also be found in adjacent oak woodlands. Thus, the bird community found within oak woodland patches is strongly influenced by the type of habitat that surrounds them (Sisk et al. 1997).

#### 1.7. Prioritize sites according to landscape variables (patch size, shape, connectivity) that adequately support the desired populations of oak woodland-dependent species.

Large, unfragmented, and connected areas of oak woodland should have high priority for protection, for a number of reasons. Bird species composition can be altered by habitat fragmentation. For example, the proportion of neotropical migrant species in the bird community was found to be higher in undeveloped oak woodland than in ranchette developments (Merenlender et al. 1998). The same study found a number of bird species to be more abundant in subdivided oak woodlands. These include Western Scrub-Jay, a common predator on the nests of other birds, and European Starling, an exotic competitor of cavity nesting birds (Purcell and Verner 1999). Stralberg and Williams (2002) found several bird species, mostly neotropical and short distance migrants, to increase in abundance with the proportion of oak woodland habitat remaining in the surrounding landscape.

#### 1.8. Prioritize sites according to management options.

Sites in which management can be used to restore natural ecosystem processes should be given a high priority for protection. For example, sites in which a natural fire regime can be

re-established might be assigned a higher priority than sites in which there is a need for strong fire suppression. Sites in which the impacts of grazing can be strictly managed may also be priorities for protection.

#### 1.9. Prioritize sites based on conservation threats and opportunities for protection.

The above guidelines are useful for identifying the highest quality oak woodland sites in the state, however, not all of these sites will be equally threatened by imminent habitat loss and degradation. Therefore, an analysis of impending threats and conservation funding potential should be included in the prioritization process. Habitat quality, vulnerability, and conservation potential all must be considered in designing the best conservation strategies.

#### OBJECTIVE 2

##### *Increase acreage of protected oak woodland.*

Using the above prioritization guidelines, a variety of preservation tools should be applied to increase the acreage of oak woodland in California that is managed for birds and other wildlife. These tools include: conservation easements, fee ownership of preserves, partnerships between government agencies and nonprofits, sustainable forestry and ranching, and woodland grass banking. Future versions of this plan should contain quantitative goals for oak woodland protection.

#### Habitat Restoration Recommendations

#### OBJECTIVE 3

##### *Prioritize oak woodland sites for restoration.*

#### Recommendations

##### 3.1. Prioritize restoration sites according to their proximity to existing high quality sites.

Restoration sites may be more likely to be colonized by oak woodland birds if they are close to areas of high quality habitat that can serve as sources of immigrants. Dispersal distances of oak woodland birds are largely unknown, with one exception: Acorn Woodpeckers have been shown to disperse relatively long distances (Koenig et al. 2000). However, many of the smaller, resident bird species in oak woodlands may have relatively restricted dispersal ability. If so, bird populations may be more likely to be reestablished and to persist in restoration sites that are close to areas of high quality habitat that can serve as sources of immigrants. Further research is needed to evaluate the influence of habitat isolation on oak woodland birds.

##### 3.2. Prioritize restoration sites according to likely success of regeneration and transplanted oak viability.

Restoration sites should be prioritized according to their regenerative potential. This includes not only sites with adequate acorn production and dispersal capabilities, but also with adequate biophysical (conditions e.g., soil, water table, etc.) to support seedling growth and cultivated transplants. A GIS-based system for evaluating site suitability for valley oak restoration is being developed for Santa Barbara County by Frank Davis and associates at the University of California, Santa Barbara (Davis and Kuhn, in press, <http://www.biogeog.ucsb.edu/projects/sboak/sboak.html>).

#### OBJECTIVE 4

##### *Restore protected oak woodland systems to benefit healthy bird populations.*

#### Recommendations

##### 4.1. Restore oak woodlands to promote oak regeneration.

Regeneration is a problem in oak woodlands with a large amount of oak mortality and not enough growth of seedlings and saplings to replace dying trees. In these areas, land managers may want to promote regeneration by protecting young trees from grazing and browsing animals or by planting acorns or seedlings. Because planting oaks requires intensive effort, it may be more efficient in some sites to protect seedlings and saplings where they are already present. Small oak trees may need protection from grazing animals until they have grown taller than the browse line. Active restoration of oak trees may be needed most on drier south-facing slopes (Brooks and Merenlender 2001). A variety of devices, such as screens and plastic tubing, as well as brush piles, can discourage browsing of small trees. A recent University of California manual on "Regenerating Rangeland Oaks in California" (McCreary 2001) is available through the UC Integrated Hardwood Range Management Program (IHRMP). Contact information for IHRMP and sources of other information on how to implement oak woodland restoration are available in Chapter 9.

##### 4.2. Restore understory components of oak woodland systems.

Many oak woodland birds are associated with grassland and shrub components of oak woodlands (Tables 3-1 and 3-2). Oak woodlands with a shrubby understory and downed woody material support greater numbers of small vertebrates (Tietje and Vreeland 1997, Tietje et al. 1997). The presence of shrubs and brush piles in the understory of oak woodlands may also help promote the survival of oak seedlings (Callaway 1992b, Callaway and Davis 1998, Weikamp et al. 2001).

##### 4.3. Replace non-native annual grasses with native perennial grasses in oak woodland systems.

Re-establishing or conserving native perennial grasses in oak woodlands may benefit oak regeneration, because non-native annual grasses tend to outcompete young oak seedlings for soil moisture (Gordon and Rice 1993). Also, some birds, such as the Lark Sparrow, may benefit from the presence of native grasses (Martin and Parrish 2000).

#### 4.4. Restore upland oak woodland habitats in conjunction with adjacent riparian restoration.

Many bird species use both riparian and upland oak habitats for different parts of their life cycle. For example, birds that breed in oak woodland habitat may use riparian habitat as corridors for the dispersal of juveniles and non-breeding adults. Riparian habitat may also be used for foraging and as migratory stopover grounds. In addition, birds nesting in riparian habitat adjacent to native upland habitat may experience lower rates of nest predation or cowbird parasitism (RHJV 2000).

#### 4.5. Restore natural fire regimes in oak woodlands whenever possible.

Higher fire frequencies in the era before widespread fire suppression (before the 1950's) may have created conditions that favored oak regeneration (Chapter 10 in Standiford and Tinnin 1996). Thus, restoring natural fire frequencies may contribute to improved oak recruitment. Also, low-intensity prescribed burns may help reduce fuel levels and prevent large, higher intensity fires that destroy oak stands. However, oak woodlands may also be damaged when fire frequency is too high, and the idea that changes in fire frequency have influenced oak regeneration is not entirely supported by recent studies (McCreary 2001, Swiecki and Bernhardt in press). More study is needed to identify the optimal fire frequency in oak woodlands. Therefore, this is a good area for adaptive management, which requires monitoring of the effects of different prescribed burning regimes on oak woodland plants, birds, and other wildlife.

#### 4.6. Restore a mosaic configuration of a diversity of oak woodland types.

See Recommendation 1.4.

#### 4.7. Restore oak woodlands to meet the requirements of cavity-nesting birds.

Cavity-nesting birds make up a large proportion of the bird species and a majority of the individual birds breeding in oak woodlands (Wilson et al. 1991). Therefore restoration programs should give special consideration to meeting the habitat requirements of this guild, including both primary and secondary cavity nesters. See Recommendations 6.3, 6.4, and 6.7.



Oak Titmouse

photo by Ian Tait

#### 4.8. Plant multiple species of oak tree when restoring oak woodlands

Sites with more than one species of oak present are more likely to support stable populations of Acorn Woodpeckers (Koenig and Haydock 1999). Other acorn-consuming species will benefit from this as well, because high oak species diversity helps to ensure that acorns will be available from at least one type of oak in a given year.

### Management Recommendations

#### **OBJECTIVE 5**

*Implement and time land management activities in oak woodlands to increase avian reproductive success and enhance populations.*

#### Recommendations

##### **5.1. Avoid the construction or use of facilities and pastures that attract and provide foraging habitat for European Starlings and Brown-headed Cowbirds.**

European Starlings and Brown-headed Cowbirds are insectivorous ground feeders, and therefore are attracted to pastures, other open, short-grass areas and feedlots (Morris and Thompson 1998, Purcell et al. in press). Brown-headed Cowbirds parasitize songbird nests and European Starlings compete with native species for nesting cavities (Troetschler 1976). Recent studies suggest that European Starling populations may be increasing in oak woodlands and may be more likely to nest and forage in or near grazed oak woodlands or pastures than in the center of ungrazed areas (Verner et al. 1997, Purcell et al. in press). The degree to which Starlings and Cowbirds impact native oak woodland bird populations is still

uncertain, but their presence is likely to be detrimental for some native species. Further research is also needed to investigate whether pastures and rangelands can be managed so as to reduce their attractiveness to Starlings and Cowbirds.

**5.2. Brown-headed Cowbird trapping should only be used as an interim/emergency measure.**

Cowbird control has been effective in stabilizing declines of endangered species in limited populations breeding in riparian habitats. For example, cowbird trapping lowered parasitism rates in a Willow Flycatcher population on the South Fork Kern River (RHJV 2000), and populations of Least Bell's Vireos at Camp Pendleton appear to be increasing as a result of cowbird trapping (USFWS 1998). However, endangered species can never fully recover as long as they rely upon human intervention for their survival (Kus 1999). A National Cowbird Advisory Council was formed to address trapping issues, review trapping programs on a case by case basis, and advise land managers and regulatory agencies. Expert opinion suggests that cowbird trapping is at best a temporary stopgap solution, and it is preferable to manage habitat and human use in ways that lessen the negative impacts of cowbirds (Morrison et al. 1999, and the National Cowbird Advisory Council).

**5.3. Limit restoration activities and disturbance events such as grazing, prescribed fire, firewood harvesting, disking, and herbicide to the non-breeding season (which varies by region, but is typically August through February in California).**

Such disturbances during the breeding may have direct impacts on the nesting success of oak woodland species, especially ground or shrub nesters. These activities may be much less detrimental to birds if conducted during the non-breeding season. Although few studies have directly tested this hypothesis, a recent study found no effect of an October prescribed burn on bird abundance in coastal-central California oak woodland (Tietje and Vreeland, in press).

The effects of grazing in particular need further study. While grazing did not appear to have a large effect on oak woodland bird densities at the San Joaquin Experimental Range (Verner et al. 1997), further study is needed into possible effects on primary population parameters such as reproductive success. Grazing probably contributes to the long-term lack of oak recruitment in many areas, which will in time have serious consequences for bird populations. Thus, grazing should be managed so as to promote oak recruitment. There is some evidence suggesting that winter grazing is less damaging to blue oak seedlings than spring or summer grazing (Hall et al. 1992).

Grazing, prescribed fire, and mechanical treatments such as disking can be useful tools in habitat restoration, for example to promote the growth of native perennial grasses (Tu et al. 2001). In some cases, these treatments may be most effective during the breeding season. If so, land managers should carefully weigh the long-term benefits of the management action against the short-term costs to avian productivity. Long-term use of such treatments in the breeding season should be avoided.

**5.4. Manage for a grass and shrub understory where bioregionally appropriate.**

See Recommendations 4.2 and 4.3.

**5.5. Manage or influence management at the landscape level.**

Managing at the landscape level means taking into account interactions among the different habitat patches and ecosystems that make up a region. The presence and abundance of birds in a patch of oak woodland can be influenced by characteristics of the habitat mosaic surrounding the patch, as well as by characteristics of the individual patch (Sisk et al. 1997, Stralberg and Williams, 2002). Linking and buffering large sections of oak woodland and associated habitats may restore top predators, such as coyotes or bobcats, to the oak woodland system. These predators may, in turn, reduce populations of avian nest predators such as skunks, raccoons, and snakes (Soulé et al. 1988). Landscape-scale land-use patterns may affect the population levels of Brown-headed Cowbirds and avian predators in an area, and thus reduce avian productivity. However, research on the demographic effects of habitat fragmentation is lacking for California oak woodlands, and one study in a western landscape suggests that fragmentation may not always cause increased nest predation (Tewksbury et al. 1998). More generally, the theory of island biogeography predicts the gradual extirpation of small populations from isolated habitat fragments (MacArthur and Wilson 1967). Landscape-scale management is also needed to prevent the invasion of protected habitat patches by exotic plants and animals (e.g., Suarez et al. 1998). Implementing landscape level management often will require cooperation with regional organizations such as regional fire councils, weed abatement districts, watershed conservancies, and Resource Conservation Districts.

**OBJECTIVE 6**

*Protect, enhance or recreate natural oak woodland processes and characteristics.*

**Recommendations**

**6.1. Maintain diverse age structure of oak trees.**

See Recommendation 1.3.

**6.2. Protect seedling and sapling trees to enhance oak recruitment.**

Oak seedlings and saplings remain vulnerable to damage by herbivorous animals, including grazers, browsers, and small mammals, until they have grown taller than the grazing line (usually about 5 feet). Managers may want to consider placing protective structures around these young trees.

**6.3. Retain decaying or dead oak trees, limbs, snags and mistletoe.**

Some cavity-nesting birds, such as the Plain Titmouse and White-breasted Nuthatch, nest primarily in natural cavities (Wilson et al. 1991). Therefore, the injured and decaying trees in which these cavities often form are an important habitat element for these species. Allowing dead limbs to remain on living trees may provide entry points for decay-enhancing organisms, which in turn allow birds to excavate cavities in the rotting wood. An analysis using the California Wildlife Habitat relationships System (CWHRS) estimated that over 50 species of birds use snags for breeding, feeding and/or cover (Guisti et al. 1996). Mistletoe is known to be an important winter food for Western Bluebirds (see Species Account for details).

#### 6.4. Retain large oak trees whenever possible.

Acorn Woodpeckers will benefit from the presence of large diameter trees (> 50 cm DBH), which they prefer to use for nesting and as granary trees (Gutierrez and Koenig 1978, Wilson et al. 1991). One study in the Bay/Delta bioregion found that granaries were almost exclusively found in deciduous oaks greater than 75 cm in diameter (Wilson et al. 1991), while softwoods such as pines are preferred in other areas (see species account for more details). Sustaining Acorn Woodpecker populations is likely to be beneficial to secondary cavity nesting species, such as Western Bluebirds, which often use old excavated nests. Large trees often contain many natural cavities for nesting birds, and are disproportionately chosen for site sites by Red-tailed Hawks (Tietje et al. 1997a). See recommendation 1.3.

Large oak trees also produce more acorns than smaller trees, providing both a source of oak recruitment and food for wildlife. Therefore, in the absence of any data on actual acorn production, the largest trees should be retained. Also, certain individual trees may produce more acorns, have more large branches and produce larger snags and logs for wildlife use than other trees. Therefore, these especially valuable individual trees can be identified and retained to benefit birds and other wildlife. The acorn production of individual trees can be visually estimated in early fall (for instructions, see McKibben and Graves 1987 or Guisti et al. 1996). Acorn crops vary from year to year, so Guisti et al. (1996) recommend observing individual trees over 2-3 years and McKibben and Graves (1987) recommend observing trees in at least one high acorn production year. If data from multiple years are not available, it would still be beneficial to retain those trees that produce the most acorns in any given year, because the same individual trees tend to be good producer from year to year (Chapter 9 in Standiford and Tinnin 1996).

#### 6.5. Control and eradicate non-native animal species.

The presence of non-native animals, such as European Starlings, feral cats, and pigs, may be harmful to native birds. Non-natives may compete with or prey on native birds, or may impact the suitability of oak woodlands for birds via their effects on vegetation. A recent study suggests that feral pigs may have significant negative impacts on acorn availability for wildlife and the establishment and growth of oak seedlings (Sweetzer and Van Vuren in press).

#### 6.6. Utilize thinning of oak woodlands as a replacement for complete oak removal in rangelands.

It may be very difficult for oak woodlands to reestablish themselves after being completely removed (Brooks and Merenlender 2001). Much regeneration takes place under the canopy of larger trees where optimal conditions for establishment exist, e.g. moisture, nutrients (Swiecki and Bernhardt 1998). For example, blue oak seedlings do not survive well in areas without some canopy cover. The conversion of oak woodlands to grasslands will obviously cause reductions in the numbers of oak woodland birds present. There is some evidence that thinning of oak woodlands may not have dramatic negative effects on common oak woodland birds, especially if small patches are thinned (3 ha or less), if thinning reduces the basal area of trees by < 25%, and if large trees, trees with nest cavities, and Acorn Woodpecker granary trees are preserved (Aigner et al 1998). Leaving brush piles after thinning may cause increases in population density of some bird species, such as California Quail and Bewick's Wren. However the effects of thinning on uncommon species is uncertain. If oak woodlands are thinned, the most valuable trees for wildlife should be preserved (Garrison and Standiford 1997), as outlined above in Recommendations 6.3 and 6.4.

#### 6.7. Manage for a diversity of oak species within the appropriate bioregion.

Research has shown that cavity-nesting birds use a variety of trees for nest sites, suggesting that these birds will benefit from having many alternative nesting substrates available (Wilson et al. 1991). Because different oak species do not mast synchronously, high oak species diversity will also help ensure that acorns will be available from at least one type of oak in a given year, thus benefiting acorn-consuming birds (Koenig and Haydock 1999).

#### 6.8. Design and implement cultivated restoration projects that mimic the diversity and structure of a natural oak woodland plant community.

The response of birds to riparian habitat restoration suggests that cultivated restoration sites are more beneficial to birds if they mimic the diversity and structure of naturally occurring habitats (RHJV 2000). If this is also true in upland habitats, then some of the cultivated restoration recommendations in the Riparian Bird Conservation Plan may be applicable to oak woodlands. For example, this would suggest that restoration projects should include the planting of multiple species of trees as well as native understory plants such as shrubs, herbs, and grasses. Also, planting oak trees in a clustered pattern or planting young trees under the canopy of existing trees may promote the recruitment of additional oaks and benefit birds.

#### 6.9. Maintain corridors between oak woodlands and other habitats.

Many of the birds found in oak woodlands use other habitat types during parts of their life cycles. Therefore, the diversity of birds and the health of their populations will likely be greater when oak woodlands are connected to other habitats by corridors of native vegetation.

**6.10. When harvesting firewood in oak woodlands, identify and retain important resources for wildlife.**

The results of one study on light firewood harvesting (basal area of trees reduced by less than 25%) in a California oak woodland suggest that protecting granary trees, nest cavities and some dead limbs, creating brush piles, and harvesting in small patches may help maintain bird populations in harvested oak woodlands (Aigner et al. 1998). In addition, Standiford (1996) recommended that following guidelines be followed: preserve individual trees which produce the most acorns, preserve at least one snag (i.e., dead tree) per acre, allow buffer zones with no harvesting adjacent to riparian areas, and protect sprouting stumps and existing small seedlings and saplings. Guidelines for how to identify which blue oaks produce the most acorns can be found in McKibben and Graves (1987). More research is needed to understand the long-term, large-scale effects of firewood harvesting in oak woodlands.

**OBJECTIVE 7**

*In private commercially managed oak woodland habitats (i.e. vineyards, agricultural fields, and housing developments), maintain habitat characteristics sufficient to support native bird populations. Work cooperatively with agricultural researchers to encourage vineyards and orchards adjacent to existing oak woodlands to be more "bird friendly."*

**Recommendations**

**7.1. Retain connected oak patches within managed landscapes.**

Developed or agricultural areas may still provide habitat for some oak woodland birds if oak patches are retained (Scott 1993, Stralberg and Williams, 2002). The long-term health of these bird populations is not known, but is likely to be improved by connectivity among retained oak patches. See recommendation 10.1.

**7.2. Retain oak trees in addition to herbaceous, grass or scrub understory.**

Oak removal has historically been recommended to increase forage production for livestock. However, research suggests that removing blue oaks results in little or no improvement in forage production in areas receiving less than 20 inches of rain per year (see review of research in Chapter 5 of Standiford and Tinnin 1996). Indeed, in drier parts of the state, deciduous oak canopy cover can enhance forage production. Rangeland experts also recommend that areas where oaks are thinned should retain oak canopies of at least 25-35% to help maintain soil fertility, minimize soil erosion, and provide wildlife habitat (ibid).

**7.3. Maintain oaks around residences and other landscaped areas by avoiding soil compaction and over-watering.**

Native oaks are valued parts of many yards and parks, and may be harmed by soil compaction or inappropriate irrigation. For example, watering near the base of a native oak during the warm season can cause root and crown rot. Detailed instructions for oak care are available from the California Oak Foundation and the UC Integrated Hardwood Range Management Program (see Appendix A for contact information).

**7.4. Retain patches of chaparral, riparian or grassland habitats adjacent to patches of retained oaks.**

The presence of these habitats adjacent to oak patches may improve conditions for native birds. See also recommendation 1.5, 1.6, and 4.4

**7.5. Avoid attracting non-native bird species.**

Non-native birds may compete with native birds for resources, including nest cavities. In oak woodlands, European Starlings are of particular concern in this regard. See also recommendations 5.1 and 6.5.

**7.6. Avoid attracting or supporting inflated populations of nest predator species.**

Homeowners can avoid this by not providing food for avian nest predators such as jays, magpies, crows, and ravens in the breeding season and by not feeding stray or feral cats.

**7.7. Refrain from utilizing pesticides or herbicides if possible.**

Within developed areas, landowners may benefit bird populations by avoiding landscaping methods that require the use of pesticides. Agricultural landowners adjacent to oak woodland habitat may use integrated pest management or organic productions as an alternative to pesticide use. This prevents damage to nesting birds and increases available foraging habitat.

**7.8. Retain natural cavities instead of using nest boxes, whenever possible.**

The loss of naturally occurring cavities cannot be completely mitigated by providing nest boxes. Although nest boxes can provide good nesting sites for several species of cavity nesting birds, they also have the potential to alter the composition of the bird community by benefiting some species more than others (Purcell et al. 1997, Mummert et al. in press). Also, if not properly maintained year after year, nest boxes can provide nest sites for non-native species such as European Starlings. Therefore, it is preferable to retain natural cavities whenever possible. In addition, nest cavities may not be a limiting factor in all oak woodlands, and natural nest availability should be assessed before implementing nest-box programs in oak woodlands (Waters et al. 1990).

**7.9. Conduct management activities such as mowing herbaceous and grass layers in the non-breeding season.**

See recommendation 5.3.

**7.10. Seek opportunities to work with landowners and influence the layout of new vineyards to be located in oak woodlands, to ensure that oak harvest or reduction conforms as much as possible to the above recommendations.**

#### **OBJECTIVE 8**

*Inform private landowners of the imminent decline of oak woodlands due to habitat loss and lack of regeneration, and of the subsequent effect on landbird populations.*

#### **Recommendations**

**8.1. Support active outreach to private landowners through established programs such as local Resource Conservation Districts, the Natural Resources Conservation Service, and UC Cooperative Extension.**

Many landowners may be interested in managing for oak woodland birds if given the opportunity to do so on a voluntary basis. Resource Conservation Districts can use their established contacts with private landowners as the basis for providing information on how to manage for oak woodland birds. For example, wine-grape growers are often interested in deploying nest boxes on their land to benefit cavity nesting songbirds and owls that may prey on pest insects and rodents. Therefore, the Southern Sonoma Resource Conservation District has recently begun a project to monitor avian reproductive success in nest boxes on Sonoma County vineyards. This project, which is a collaboration between private landowners, the RCD, UC Extension researchers, and PRBO, will provide information to landowners about the use of nest boxes in vineyard-oak woodland habitats. Such programs should be encouraged to help inform and build partnerships with private landowners.

#### **Monitoring/Research Recommendations**

#### **OBJECTIVE 9**

*Provide data on pressing conservation issues affecting birds.*

#### **Recommendations**

**9.1. Consider reproductive success and survival rates when monitoring populations, assessing habitat value, and developing conservation plans.**

The value of a habitat for oak woodland birds depends largely on their ability to survive and reproduce there (Block and Morrison 1987). Although many monitoring programs focus on species' abundances, abundance alone is an inadequate, and sometimes misleading, measure of habitat quality (Van Horne 1983). Likewise, long-term trends in bird populations depend

on survival and reproductive success rates. Therefore, monitoring programs should include the estimation of these demographic parameters whenever possible.

**9.2. Conduct intensive, long-term monitoring at selected sites. In order to analyze trends, long-term monitoring should continue for more than 10 years.**

Intensive long-term monitoring can provide crucial, habitat-specific information on bird population trends. Because oak woodland bird numbers are highly variable from year to year (e.g., Verner and Purcell 1999), most monitoring projects will need to continue for at least 10 years to be able to detect significant trends in abundance or to provide reliable baseline data (Verner et al. 1996). A long-term study of oak woodland birds by Forest Service biologists at the San Joaquin Experimental Range has produced many useful guidelines for designing and implementing a monitoring program (Verner and Ritter 1985, Verner 1987, Verner and Milne 1989, Verner et al. 1996). A project is currently underway, using this long-term dataset, to determine the optimal sample size and number of years required to detect population trends using point counts.

Because apparent trends in oak woodland bird populations can be caused by climatic factors, such as a period of low precipitation, rainfall and temperature should be included as explanatory variables in trend analyses (Purcell et al. in press).

**9.3. Conduct selective monitoring at critical sites to determine the factors influencing nest success of representative open cup nesters: Lark Sparrow, Blue-gray Gnatcatcher, Western Scrub-Jay, California Thrasher, California Towhee and Hutton's Vireo.**

Low productivity can be an important factor leading to population declines and local extinctions in open-cup nesting birds (Johnson and Geupel 1996, Gardali et al. 2000). By determining the factors associated with low reproductive success, research may identify which management and restoration actions will help prevent or reverse songbird population declines. Land managers, owners and regulatory agencies gain greater freedom in their decision-making if they conserve bird species before special-status listing becomes necessary. Monitoring key species provides gauges that allow management changes before it is too late.

Monitoring sites ideally should be selected in a methodical, randomized fashion so that the effects of various local habitat, landscape, and management conditions on reproductive success can be evaluated through statistical inference. Anthropogenic factors of interest include: grazing, prescribed fire, mowing, development density, landscaping and garden characteristics, and abundance of non-native predators.

**9.4. Monitor nests in natural or excavated cavities.**

Because cavity nesters make up a significant proportion of oak woodland birds, it is essential to understand the influences on their productivity when nesting in natural cavities (as opposed to artificial nest boxes). The impact of competition for nesting cavities by European Starlings on native birds should also be monitored.



**9.5. Monitor effects of Western Scrub-Jay and Yellow-billed Magpie populations on other oak woodland species.**

Western Scrub-jays and Yellow-billed Magpies can act as predators on the nests of other native birds (Purcell and Verner 1999). Although jays and magpies are native to oak woodland habitats, they may be a conservation threat in areas where their populations are increased due to human activities. For example, Western Scrub-jays are known to be more abundant near human developments (Merenlender et al. 1998, Stralberg and Williams, 2002).

**9.6. Monitor effects of Brown-headed Cowbird and European Starling populations on other oak woodland species and research how habitat management can be used to minimize adverse effects.**

See recommendation 5.2.

**OBJECTIVE 10**

*Use information gathered in avian monitoring programs to test specific oak woodland habitat needs for bird species.*

**Recommendations**

**10.1. Identify minimum thresholds of connected oak woodlands in urban, agricultural and vineyard fragments.**

To assist in conservation planning, we need to know, for example, what is the minimum number of oaks and maximum spacing between oaks that will still provide habitat for oak woodland bird species. Such information will help landowners practice “bird friendly” agriculture and development.

**10.2. Study edge effects in oak woodland habitats.**

Research into how oak woodland habitat edges relate to bird use, nest predation and cowbird parasitism is needed. There is some evidence suggesting that nest predation rates are lower at “soft” habitat edges than at abrupt, “hard” edges (Suarez et al. 1997, Soderstrom et al. 1998). However, no research on this subject has been conducted in western oak woodlands. Given that many of our protected oak woodlands may border unprotected or developed lands, it is important to know if edges can be managed or restored so as to minimize negative edge effects.

**10.3. Compare areas heavily affected by Sudden Oak Death with those that are not, with attention to effects on acorn production, and how that affects the food chain.**

Sudden Oak Death might affect bird populations through changes in forest structure and resulting changes in acorn supply and invertebrate numbers, which could potentially spread throughout the food web. Because the effects of SOD on bird populations will probably develop over a long time period, long-term, large-scale monitoring as well as shorter-term, intensive research efforts are needed. Bird monitoring projects in oak woodlands should routinely include the standardized collection of data on stand structure, including numbers of dead or dying trees, along with other habitat data.

**10.4. Examine winter use of oak woodlands by bird species.**

Relatively little is known about the winter ecology of oak woodland birds. More study is needed to understand which species depend on oak woodlands in winter and what characteristics of oak woodland best promote over-winter survival.

**10.5. Study the association between the shrub understory and oak woodland avian diversity and composition.**

Continued research on the current and historic occurrence of shrub understory and its value for birds is needed to evaluate the importance of managing for this vegetation layer in oak woodlands (Tietje and Vreeland 1997, Tietje et al. 1997).

**OBJECTIVE 11**

*Study the effects of management practices on oak regeneration and bird populations.*

**Recommendations**

**11.1. Monitor the effectiveness of progressive grazing regimes for increasing the rate of successful oak tree regeneration.**

It has been suggested that rotational grazing on subdivided pastures can increase the vigor of native grass species, reduce weeds, and promote oak regeneration (George 1991), but little research has yet been done to evaluate this management technique in oak rangelands (but see Jansen et al. 1997). The effects of specific grazing management strategies on oak regeneration and avian productivity should be studied in an adaptive management framework.

**11.2. Study the effectiveness of prescribed fire to reduce non-native annual grasses and facilitate germination and growth of oak seedlings.**

As outlined in Recommendation 4.5, fire is a natural process that influences oak recruitment and oak woodland structure. While light intensity fires may benefit oak growth by reducing competition with annual grasses, higher intensity fires can also damage young oaks (Tietje et al. 2001). More research on issues such as fire timing and frequency is needed to understand

how prescribed fire can best be used to promote oak regeneration, while also benefiting oak woodland birds.

### 11.3. Study the effectiveness of “wildlife-friendly” agricultural practices in vineyards and vineyard landscapes.

The winegrape growing industry is increasingly interested in making vineyard development and management less detrimental to birds and other wildlife. The effects of these efforts on birds should be monitored and compared with more traditional management practices in several bioregions.



Vineyards in oak habitat

photo by Geoff Geupel, PRBO

#### OBJECTIVE 12

*Maximize the effectiveness of ongoing monitoring and management efforts.*

#### Recommendations

##### 12.1. Increase communication and coordination between land managers and specialists hired to implement specific projects or conduct monitoring.

Adaptive management is given much attention and is widely discussed, but land managers rarely have adequate time to evaluate the effects of their projects. When managers work with specialized experts, they have an excellent opportunity to conduct “adaptive management” on an informal basis. Experts, such as those conducting endangered species or biodiversity inventories, should be consulted and included as part of project implementation teams. By doing so, managers can quickly and easily access a wealth of detailed information about local birds, other wildlife, and their responses to management activities.

##### 12.2. Use standardized monitoring protocol.

By standardizing monitoring techniques, researchers ensure that results can be compared across space and time. The USDA Forest Service published guidelines for standardized techniques of monitoring birds (Ralph et al. 1993). Please refer to Appendix B for more information. Standardized methods for measuring habitat variables, such as vegetation structure and composition also should be developed and adopted. Oak woodland databases should also be standardized to facilitate the sharing of Geographic Information System (GIS) datasets.

##### 12.3. Sierra Nevada Framework efforts should seek to incorporate a program of monitoring bird populations to assess avian responses to blue oak woodland and montane hardwoods management alternatives.

##### 12.4. Natural Communities Conservation Planning (NCCP) and development mitigation projects initiated by cities, counties, developers or other land managers should seek to incorporate long-term monitoring and current information on avian populations.

#### Policy Recommendations

#### OBJECTIVE 13

*Encourage the development of new programs with two complementary goals: (1) make it easier for private landowners to foster oak regeneration on their property, and (2) make it more difficult for large-scale clearing of oak woodland to take place without adequate mitigation.*

#### Recommendations

##### 13.1 Support focused and creative action by the California Wildlife Conservation Board (WCB) in implementing the recently (2001) passed Assembly Bill No. 242, the Oak Woodland Conservation Act (the Act).

This bill authorizes the establishment of the Oak Woodland Conservation Fund for the protection and conservation of oak woodlands throughout the state of California, to be administered by the WCB. The Oak Woodland Conservation Fund may be used to offer financial incentives to private landowners to protect and promote biologically functional oak woodlands over time. Conservation easements, land improvement, and public education and outreach are some of the activities that may be funded as a result of this bill.

The WCB program has exciting potential for working creatively and constructively with landowners to promote good land stewardship. A program to encourage and facilitate efforts to improve oak regeneration on private lands should be emphasized statewide.

Conservation groups, Resource Conservation Districts, city and county planning departments, parks departments and private landowners should focus on the following specific objectives with respect to implementation of the Oak Woodland Conservation Act:

1. Support continued legislative appropriations to the Oak Woodland Conservation Fund on an annual basis.
2. Seek to maximize the benefits of proposed oak woodland conservation programs and projects by coordinating with local land use planning agencies and zoning guidelines.
3. Seek to influence the development of local jurisdiction “oak management plans” (required by the Act) to ensure that the ecological components necessary to support a diverse avian/wildlife oak woodland community are incorporated.
4. As provided for in the Act, seek to participate in developing the guidelines and criteria for awarding grants under this program.
5. Support or promote the use of appropriate sources of federal conservation funding for deposit into the Oak Woodland Conservation Fund. Appropriate federal sources include CARA (the Conservation and Reinvestment Act).

**13.2. Promote the passage of legislation that would make large-scale removal of oaks in intact oak woodlands subject to the California Environmental Quality Act (CEQA).**

Unless the environmental and cumulative impacts of oak woodland removal are considered prior to approval of land development projects, continued unmitigated habitat loss and fragmentation will occur. CEQA compliance for oaks woodland impacts may help to decelerate the loss and fragmentation of oak woodland habitats, particularly in the wine growing regions of Northern California.

**13.3 Promote legislation that provides funding for oak woodland research, monitoring and management.**

**13.4. Promote the passage of oak preservation ordinances and smart-growth planning initiatives at the local (city and county) level, including:**

- County and city general plan updates.
- Collaborative, inter-agency regional planning efforts.

County planning agencies are often interested in incorporating the conservation of oak woodland habitats into their comprehensive plans. Examples include the effort of Santa Barbara county to design an Oak Protection Program for the county’s rural areas (Leider, in press, [www.sbcountyplanning.org](http://www.sbcountyplanning.org)) and Placer County’s Legacy Open Space and Agricultural Conservation Program ([www.placer.ca.gov/planning/legacy/legacy.htm](http://www.placer.ca.gov/planning/legacy/legacy.htm)). Although often controversial, such policies and ordinances should be supported by conservation science and should include measurable performance standards that focus on protecting large patches of oak woodland habitat, not just individual trees (Harris and Kocher, in press).



## Chapter 9. Outreach and Education

Scientific efforts for conservation have little impact without the support of affected local communities, including private landowners, government land managers, and the general public. To gain crucial support, research and management programs must share their findings and involve the interested parties at all levels of the conservation enterprise.

For the purposes of this chapter, outreach refers to communication with land managers, agencies, planners, business interests, nonprofit organizations, academia, and volunteers. Outreach activities include conferences and workshops that facilitate communication among experts, participation in land use planning, volunteer restoration and monitoring programs, field trips and classes for school children, and ecotourism.

Education, an important component of outreach, refers to the range of activities that educate and involve students and adults. Education activities include visits for classes and groups to field sites, interpretive displays, specialized curricula, and participation in festivals.

### Project-Based Learning

One method of educational outreach, called project-based learning, allows an open-ended approach to solving a conservation problem. Students identify a conservation issue in their community and plan and implement conservation projects from beginning to end. Teachers and students make the important decisions, while working with biologists, business people, private landowners and others in the community. Because of this investment, students take ownership of their work, and the lessons learned are profound and long-lasting (Rogers, pers. comm.).

Conservation education sensitizes people to environmental problems and encourages them to seek solutions. As they become involved, people develop a greater connection to issues such as habitat degradation and loss, songbird declines, and species extinction. Conservationists have little hope of achieving their goals without cultivating this interest in the public.

Education programs engage participants most effectively when they involve hands-on activities. Conservation education has the whole of the outdoors as a classroom—what better way to elicit the interest and enthusiasm of students and the public?

### Education Opportunities

Since oak habitats are such noticeable and accessible habitats, they provide excellent opportunities for hands-on experience for school groups. In fact, many schools and homes are surrounded by areas of open space containing oak woodland habitat. This close

proximity creates easy access for field visits to observe birds and other wildlife in this habitat. In addition, many oak woodland areas contain a bluebird nest box program. If you are involved in a bluebird nest box program make sure you are not doing more harm than help by following the guidelines of the North American Bluebird Society (<http://www.nabluebirdsociety.org/>) for proper installment, monitoring, and maintenance of nest boxes. If you would like to start a nest box program or install a nest box at your school, nature center or even home follow all the guidelines of the North American Bluebird Society.

The following is a list of key topics to emphasize in Oak Woodland educational projects:

- ◆ The different types of oaks
- ◆ The oak lifecycle and its dependency on birds for propagation
- ◆ Cavity abundance in oak woodlands supports a high diversity of cavity nesting birds
- ◆ The influence of acorns on native peoples culture and their use of fire to stimulate acorn production

The concepts and guidelines outlined above and in the Conservation Education section can be presented to the public and to students through a variety of media. Following is a list of common education opportunities and some suggestions for content:

#### Classroom Education

Programs in the classroom should focus on communicating key concepts to students through hands-on activities. Lessons should stress studying birds in the field - whether in the backyard, on school grounds, or in a nearby natural area - and include keeping field notes and observing natural behaviors of birds. Field trips to sites with bird conservation and monitoring projects, fosters interest and enthusiasm for wildlife and teaches students the importance of conserving birds.



photo by PRBO staff

A great way to get students interested in birds is to get them out looking at them. While access to binoculars is sometimes limiting, you can contact your local Audubon Society, Nature Center or other local wildlife education group to see if sets are available for check out. If you feel uncertain of your birding skills, contact your local Audubon Society or Nature Center to arrange for docents or naturalists who will be able to join your class for a

day of birding in the field. An invaluable experience that catches students' interest immediately is to visit a mist-netting site where students will have the opportunity to examine birds up close and interact with biologists.

There are many excellent sources for curriculum and hands-on bird activities to be done in the classroom. Through the Point Reyes Bird Observatory, Teacher Resource Packets are available containing lesson plans and activities for students of all ages, geared towards teaching students how to observe and study birds. To acquire the PRBO Teacher Resource packets contact Melissa Pitkin, 4990 Shoreline Hwy, Stinson Beach, CA 94970 (415) 868-1221 ext. 307, or email at [mpitkin@prbo.org](mailto:mpitkin@prbo.org).

Each year PIF produces a resource directory containing bird related resources on education programs and materials, education web sites, activities for kids, workshops, and more. To acquire this guide contact Susan Bonfield, PO Box 23398, Silverthorne, CO 80498 or email [Sbonfield@aol.com](mailto:Sbonfield@aol.com). Another useful source is *A Guide to Bird Education Resources* produced by Partners In Flight and National Fish and Wildlife Foundation. Copies of this book are available from American Birding Association Sales, PO Box 6599, Colorado Springs, CO 80934, phone 1-800-850-2473, [member@aba.org](mailto:member@aba.org).

#### Other Oak Woodland Educational Resources

- **North American Bluebird Society:** Bluebird Poster and Pocket Field Guide Student Packet, Bluebird Nestbox Plans, and Bluebird Newsletter P.O. Box 74 Darlington, WI 53530 608/329-6403, email: [nabluebird@aol.com](mailto:nabluebird@aol.com); Online at: <http://www.nabluebirdsociety.org/>.
- **Acorn Naturalists Materials:** Available at: <http://www.acornnaturalists.com/p905.htm> or at 155 El Camino Real P.O. Box 2423 Tustin, CA 92781-2423 Phone 1-800 422-8886
- **Investigating the Oak Community:** a curriculum designed to involve 4th through 8th grade students in activities that will develop their awareness, understanding, and knowledge of the important role of oaks in the California landscape. Available at <http://www.californiaoaks.org/html/merch2.html>.
- **Books on Oaks and Oak Woodland Habitat:**
  - Grandmother Oak*, Rosi Dagit, Gretta Allison (Illustrator); Roberts Rinehart Pub., Jan. 1997.
  - In a Nutsbell*, (Sharing Nature with Children Book), Joseph Anthony, Cris Arbo (Illustrator); Dawn Publications, Sept. 1999.
  - Oaks of California*, Bruce Pavlik, Pamela Muick, Sharon Johnson; Cachuma Press, 2000 (revised).

*Webs of Life (Oak Tree)*, Paul Fleisher, Jean Cassels; Library Bindings, January 1998.

*The Life of an Oak Tree: An Intimate Portrait*, Glen Keator, Susan Bazell (Illustrator); Heydon Books, April 1998.

- **The California Environmental Resources Evaluation System** (<http://www.ceres.ca.gov/>) has a great list of resources for Natural Sciences Educators at: [http://www.ceres.ca.gov/education/educators/nat\\_sci.html](http://www.ceres.ca.gov/education/educators/nat_sci.html)
- **Cal Alive!** An interactive CD-Rom for 4th-8th graders focusing on CA biological diversity. Software is available at the following website: <http://www.calalive.org/index-big.html>.

### Volunteer Involvement

Enlisting volunteers to aid in data collection and restoration is an excellent way to gain additional help. It is one of the best ways to teach people about conservation. Increasingly, families and school groups have opportunities to participate in cultivated habitat restoration projects at local parks or nature preserves. Volunteers that participate in counting and studying birds quickly develop a connection to them, which intimately involves the volunteer in the conservation effort. Furthermore, volunteers provide additional support and resources that make long-term monitoring of songbirds viable. To ensure reliable data collection, supervisors must match monitoring techniques with the skill level of the volunteer.

Volunteer projects monitoring bluebird nest boxes are an excellent way to ensure that bluebird boxes are monitored as well as providing a wonderful opportunity for volunteer involvement. If you are coordinating a volunteer bluebird nest box project please follow the guidelines of the **North American Bluebird Society**. You can find these guidelines on-line at <http://www.nabluebirdsociety.org/>.

### Interpretation at Natural Areas

Interpretation is an excellent way to disseminate key concepts about bird conservation to the public. Displays at preserves, nature trails, picnic areas, and other natural areas should highlight the birds using the habitats and show the specific features of the habitat that are critical to bird reproduction and survival, including native plants. Some effective displays illustrate how individuals can make a difference at home, by planting native plants in their yards or restraining cats from killing birds. These displays should be aimed at the general public, emphasizing the causes of the decline of songbirds. Again, integrating people as part of the solution encourages their support for conservation issues.

### Participation in Birding Festivals and Environmental Fairs

Birding festivals are becoming a popular means of increasing ecotourism, which can help to promote local support for conservation of natural areas—a requirement for long-term sustainability of conservation actions. Festivals also present an excellent opportunity to further educate people already familiar with birds about the scientific reasons behind bird conservation. Birders already recognize and love birds and can easily be taught the reasons for bird conservation and what a healthy population of birds needs to survive. They also constitute a pool of experienced observers who may volunteer for monitoring programs. The second Saturday in May is International Migratory Bird Day and National Keep Your Cat Indoors Day. Creating a display or festival in honor of these days is a great way to spread the word about bird conservation to your community.

Representation of bird conservation at environmental fairs is another way to reach large numbers of people and convey the key concepts behind bird conservation. Booths displaying information on how individuals can help birds along with interactive games or activities for children engage families and visitors in bird conservation topics. The National Fish and Wildlife Foundation has published *Bridges to Birding*, an interactive program for introducing birds, bird watching and bird conservation to your community. It contains step by step instructions on how to put on a festival or fair focusing on birds. To obtain a copy contact IMBD Information Center at (703) 358-2318 or [IMBD@fws.gov](mailto:IMBD@fws.gov). For more information on National Keep Your Cat Indoors Day, contact the American Bird Conservancy or visit <http://www.abcbirds.org/cats/catsindoors.htm>.

### Oak Woodland Outreach

Many groups are already working together on projects to preserve and educate people about Oak Woodland habitats. Activities ranging from workshops, management guidelines, new partnerships, and educational curriculum are being conducted by these groups. The groups and their activities are summarized below:

**The California Oak Foundation (COF)** was founded in 1988, and provides technical assistance and educational materials to those engaged in protecting oak woodlands and planting oak trees.

The California Oak Foundation works to:

- Encourage adoption of state laws protecting oaks, general plan amendments, ordinances by local, regional, and state agencies to conserve oaks;
- Co-publish oak books and educational materials, including "Oaks of California," "The Life of an Oak," and "Compatible Plants Under and Around Oaks;"
- Develop educational curriculum and provide information to schools and other community groups for acorn planting and tree maintenance projects;

- Educate decision makers, individuals and communities about threats to our endangered oak heritage;
- Sponsor technical conferences on oak preservation and workshops on estate tax planning and conservation easements in urban and rural environments for planners, developers and landowners.

For more information see Appendix A: Resources.

#### University of California Integrated Hardwood Range Management Program

<http://128.48.5.253/ihrmp/>

The Program's purpose is developing alternative land use planning and range management strategies to ensure multiple use of hardwood rangelands while improving oak regeneration and maintaining diverse wildlife habitat.

Objectives:

- Develop methods to sustain hardwood rangeland ecosystems and landscapes;
- Maintain wildlife habitat on hardwood rangelands;
- Restore degraded hardwood rangelands;
- Ensure land use planning utilizing available information to conserve hardwood rangeland ecosystems;
- Maintain economically viable private hardwood rangeland enterprises;

**Regional cooperative extension specialists** are located throughout the State to develop applied research and outreach programs addressing conservation of hardwood rangelands with local Cooperative Extension offices and various agencies and interest groups. The Extension program also develops newsletters and educational materials. <http://128.48.5.253/ihrmp/person.html>

Projects of the Program include:

- **Workshops on Guidelines for Managing Hardwood Rangelands** -- 10 workshops were presented in FY 97-98 to extend the concepts in the recently revised handbook, "Guidelines for Managing California's Hardwood Rangelands." Presented in collaboration with local county Cooperative Extension offices. Over 450 ranchers, homeowners, local conservation groups, and resource management professionals participated.
- **Development of Local-Based Oak Woodland Conservation Policies** -- The State Board of Forestry has adopted a hardwood rangeland policy to encourage local or regionally-based conservation strategies, rather than statewide regulations. IHRMP and county CE staff have helped facilitate development of these local policies. During FY 97-98, Sonoma, Fresno, and El Dorado counties implemented new hardwood rangeland

policies. These add to the other 27 counties that have already adopted local hardwood rangeland conservation policies.

- **Monitoring of Hardwood Rangeland Resources** -- Provide local feedback into state-level monitoring carried out by USDA Forest Service (USFS) and the California Department of Forestry and Fire Protection (CDF). Change detection evaluation of seven counties in the southern Sierra Nevada was completed in cooperation with local CE advisors. Work on monitoring sources of hardwood rangeland change started in the central and northern Sierra Nevada regions.
- **Develop and Extend Restoration Efforts** -- Educational programs were held with restoration professionals, native plant nurseries, and landowners on IHRMP-developed hardwood rangeland restoration technologies. Over 150 professionals were reached directly with educational workshops dealing with this topic.
- **Vineyards in an Oak Landscape** -- Conversion of hardwood rangelands to vineyards identified as key area for new program thrust. Leaflet developed to describe hardwood rangeland conservation strategies in areas being developed for new vineyards. Local regulatory restrictions proposed in Sonoma, Napa, and Santa Barbara counties, and IHRMP and county CE advisors worked closely in developing educational opportunities to present research-based information in this policy debate. Five educational workshops were held this fiscal year on this topic. A pilot GIS mapping project started in Sonoma County.
- **Economic Value of Hardwood Rangelands** -- Concerns about validity of Williamson Act appraisal processes used in the Southern Sierra Counties led to contract with Tulare County Assessor's Office to determine a scientifically defensible appraisal process. This work completed, and extended to southern Sierra Nevada county assessors in a workshop and through printed case studies. Work has helped quantify amenity and conservation value of hardwood rangelands to support developing interest in conservation easements and land trusts to conserve habitat values of hardwood rangelands.
- **California Oak Symposia** -- Together with a number of other organizations and agencies, IHRMP recently convened the fifth in a series of symposia on oaks in California. These conferences and their proceedings are rich sources of information on a wide variety of subjects related to oak ecology, management, and conservation (Standiford 1991, Pillsbury et al. 1997).

#### California Association of Winegrape Growers

CAWG was founded in 1974 to represent the interests and concerns of wine and concentrate grape growers. CAWG has begun to work with the scientific and environmental community to develop and promote awareness of wildlife-friendly vineyard practices. In 2002, CAWG organized a workshop on Vineyards and Wildlife Habitat, and plans to follow up with a publication on the subject. [www.cawg.org](http://www.cawg.org)

### Eastern Madera County Coarsegold Resource Conservation District Voluntary Oak Woodland Management Guidelines <http://www.crcd.org/>

The Coarsegold Resource Conservation District has provided this forum to furnish landowners with the latest information and provide educational material for their use in the management of their property. The data included on this site was developed to assist landowners in becoming better land stewards and direct them to publications and agencies for help in the management of their property.

**Phytosphere Research** -- (<http://phytosphere.com>) provides information needed to effectively manage plant resources in urban and rural environments, natural ecosystems, and agricultural systems. They focus especially on ecology, restoration, and management of native California oaks and oak woodlands. Their site *Understanding blue oak regeneration*: (<http://phytosphere.com/BLUEOAKF.HTM>) provides an in-depth overview of blue oak regeneration, including details on the effects of canopy and site conditions, accounting for historical regeneration patterns, sustainable management, and effects of fire and grazing. They also offer a guide to growing California oak species (<http://phytosphere.com/oakplanting/oakplanting.htm>).

### Future Outreach Priorities

Outreach activities must maintain and build interest in conservation and restoration efforts in the state. To this purpose, outreach efforts should develop:

- **Greater collaboration** between woodland managers (include public and private agencies) and biologists to examine wildlife response to management practices throughout California's varied oak woodland habitats.
- **More contact with resource-based constituencies**, such as the wine-making industry, to foster collaboration in land management, in order to improve habitat for birds while ensuring that landowners can make a sustainable living.
- **Partnership with the National Association of Service and Conservation Corps** (NASCC), of which the California Conservation Corps is a part. The California Association of Local Conservation Corps also has 11 members throughout the state with a trained labor force capable of restoring habitat. These programs improve environmental quality while providing opportunities for young people to learn and develop new skills.
- **Further educational outreach**, particularly the promotion and support of volunteer monitoring programs. Volunteer monitoring programs are most needed at reference sites and others that will require long-term monitoring.
- **Oak Woodland conferences and symposia**. These will highlight recent developments in restoration biology, innovative government programs and public and private

partnerships. They will also facilitate communication among restoration biologists, regulatory agencies, land managers, and landowners throughout the state.

### Opportunities for Involvement: What Can One Person Do?

An individual can have a profound impact on the life of a bird and the livelihood of a species. Human activities can encourage predation of adult birds and their nests by animals such as domestic cats, raccoons, and jays. They can alter available food resources by depleting local insects with pesticides. Finally, they can destroy or disrupt much-needed habitat for nesting and feeding young. But thoughtful activity by humans can limit these impacts and even encourage successful nesting by songbirds, contributing to the health of their population.

The guidelines below can make a critical difference in enhancing the health of a songbird population. These recommendations apply to most bird species, including oak woodland birds.

#### If you are a bird watcher, volunteer for a monitoring program.

There are increasing opportunities for bird watchers of all skill levels to gain training and experience in various bird monitoring techniques. Participants gain knowledge in a subject area of interest, learn new skills, and can directly contribute to the science of conservation while enjoying birds in the outdoors. There are increasing opportunities to contribute to bird monitoring projects in riparian habitats throughout the state. (See the PRBO web site <http://www.prbo.org> for ways to get involved and Appendices A and B for more information on bird monitoring techniques and the information they provide.)

#### If you own a cat, help reduce the impact of cats on bird populations.

Domestic cats kill hundreds of millions of native birds, reptiles and small mammals every year. This unnecessary impact can easily be reduced if cat owners would keep their cats indoors. The American Bird Conservancy's Cats Indoors! campaign seeks to educate the public on the facts of cat predation on birds and other wildlife, and the hazards to free roaming cats. This information is available at the American Bird Conservancy's web site at <http://www.abcbirds.org>.

#### Other actions that cat owners can take to help birds:

- **Keep cats as indoor pets.**
- **Spay and neuter your cats.**
- **Cats on ranches or farms, kept to control rodent populations, should be kept to a minimum.** Spayed females tend not to stray or wander from the barn area. Keeping feed in closed containers also helps reduce rodent populations (Coleman et al. 1997). Trapping rodents can also be more effective than relying on cats to do the job.

- **Don't feed stray or feral cat populations.** A more humane alternative for cats and wildlife is to reduce the unwanted cat population by limiting reproduction and facilitating adoption by responsible pet owners.
- **Remove food dishes or garbage that may attract stray cats.**
- **Support local efforts to remove feral cats.**

**If you camp, hike, or picnic in the outdoors help maintain the natural balance between predator and prey.**

Do not feed wildlife or allow wildlife access to your trash. This may lead to an increase in natural predators such as raccoons, fox, ravens, crows, jays, and opossum. Increased numbers of these predators can depress bird populations.

**If you feed birds, avoid doing more harm than good.**

Feeding wildlife can be beneficial if properly done, but it always carries the potential for upsetting the natural balance between native predators and prey species. Improper feeding can help to spread disease, support predator populations that prey on birds and other organisms, or increase non-native populations that displace the natives.

• **Feeder placement should be away from shrubs or bushes that provide places for cats to ambush birds (Coleman et al. 1997).**

• **Avoid feeding birds in the spring and summer.** Feeding birds supplements their natural diet, but springtime feeding may encourage a lower quality diet for nestlings who need high-protein insects, which are naturally abundant throughout the breeding season.

• **Do not supplement the diet of avian nest predators** such as jays, magpies, crows and ravens by feeding them during the breeding season. These predators tend to benefit disproportionately from human habitation, and as their populations expand they are negatively affecting the health of other bird populations. The National Audubon Society produces bird feeders that discourage use by avian predators.

• **Avoid supplementing the diet of Brown-headed Cowbirds,** which parasitize songbird nests. If cowbirds come to your feeder, try eliminating millet from the birdseed you provide. Evidence indicates that Brown-headed Cowbirds are attracted to bird feeders primarily for millet. Sunflower seeds and other types of birdseed attract many songbird species, but may not attract cowbirds.

• **When feeding birds in winter, feed them consistently.** Some wintering birds may become dependent upon winter bird feeders, thus a consistent supply of food is important. Change birdseed if it gets wet from rain as the moisture may promote mildew or sprouting, which can cause birds to become ill.

• **In feeding hummingbirds, use a solution of four parts water to one part sugar. Do not use brown sugar, artificial sweeteners or red dye.** Place the feeders in the shade and change the feeder solution every three to four days to avoid cultivating pathogens that can cause hummingbirds to become ill. In freezing weather, bring feeders indoors at dusk and return them with lukewarm fluid at dawn. Clean feeders every 10 days using a few drops of bleach in the wash water, and let stand before rinsing. Rinse thoroughly many times.

**If you find an injured bird or a baby bird:**

• **Baby birds will often leave the nest before they look fully-grown.** Such birds are often mistaken for “abandoned.” Their parents, however, can find them on the ground and will feed them. Most fledglings will continue to be fed by their parents even after leaving the nest. It is therefore best to leave young uninjured birds alone, as it is likely their parents are nearby. It is not true that parents will avoid young after humans have handled them. Fledglings should not generally be returned to their nest, as this may disturb the nest site. Trampled vegetation and human activity can alert predators to the presence of the nest. Allowing baby birds to remain in the care of their parents provides them their best opportunity for survival.

• **Injured birds can be taken to wildlife rehabilitation clinics and programs.** It is best to keep injured birds in a warm, dry, quiet place free from disturbance (such as a shoebox with the lid on and a few holes for air) until they can be transferred to a licensed wildlife rehabilitation facility. Call the facility before you visit.

• **Be aware that it is against federal law to collect birds or their nests without a permit.**



**KEY CONCEPTS ABOUT BIRD CONSERVATION**

The following list of key concepts for bird conservation should be communicated through education and outreach programs. These concepts are important to include in any program concerning conservation, and are indispensable in programs focusing on birds and riparian habitats.

- **Reproductive success may be the most important factor influencing population health.** It contributes directly to a population's size and viability in an area. A number of factors influence reproductive success, including predation, parasitism, nest site availability, and food availability.
- **Nesting habitat requirements vary among species.** Different bird species place their nests in different locations, from directly on the ground to the tops of trees. Most birds nest within five meters of the ground. Managers should consider that habitat needs for different species vary. Leave grass and forbs greater than 6 inches in height for ground nesters, shrubs and trees for low to mid-height nesters, dead trees and snags for cavity nesters, and old, tall trees for birds that build their nests in the canopy.
- **The breeding season is a short but vital period in birds' lives.** Birds nest during the spring and early summer of each year and raise their young in a rather short period. Nestlings are particularly sensitive to changes in the environment and are sensitive indicators of ecosystem health. Disturbance, such as vegetation clearing, habitat restoration, and recreation may result in nest abandonment, remove potential nest sites, directly destroy nests, expose nests to predators, and decrease food sources such as insects. Predators, such as domestic cats, skunks and jays, can decimate breeding populations, and managers should avoid subsidizing their populations.
- **Understory (the weedy, shrubby growth underneath trees) is crucial to birds.** A healthy and diverse understory with lots of ground cover offers well-concealed nest and foraging sites. Manicured parks and mowed lawns provide poor nesting conditions for all but a few bird species.
- **Native plants are important to birds.** Native bird populations evolved with the local vegetation, learning to forage upon and nest in certain species. Introduced plant species may not provide the same nutrition or nest site quality. Introduced plants can also quickly dominate an area, reducing the diversity of vegetation. Less diverse vegetation can lower the productivity and viability of a bird population.
- **Natural predator-prey relationships are balance, but human disturbance creates an imbalanced system.** Interactions with predators are a natural and essential part of an ecosystem. However, a preponderance of non-native predators or a sustained surplus of natural predators severely affects the health and persistence of bird populations. Feeding wildlife, especially foxes, raccoons, and skunks, should be discouraged. Feeders that are frequented by jays and crows and cowbirds should not be maintained during the breeding season (most songbirds feed their young insects). Domestic and feral cats are responsible for an estimated 4.4 million birds killed each day by cats (Stallcup 1991). It is not true that a well-fed cat will not hunt! In fact, a healthy cat is a more effective predator.
- **Natural processes, such as flood and fire, are integral to a healthy ecosystem.** They provide the natural disturbance needed in an area to keep the vegetative diversity high, an important factor for birds.

**Chapter 10. Literature Cited and Additional References**

- Abrams, M. D. 1992. Fire and the development of oak forests. *BioScience* 42:346-353.
- Adams, T. E., Jr., P. B. Sands, W. H. Weitkamp, and M. E. Stanley. 1997. Oak seedling establishment by artificial regeneration on California rangelands. Pp. 213-223 *in* Pillsbury et al. Proceedings of a symposium on oak woodlands: ecology, management, and urban interface issues. Gen. Tech. Rep. PSW-GTR-160.
- Aigner, P. A., W. M. Block, and M. L. Morrison. 1998. Effect of firewood harvesting on birds in a California oak-pine woodland. *Journal of Wildlife Management* 62:485-496.
- Allen, B. H. 1990. Classification of oak woodlands. *Fremontia* 18:22-25.
- Alpert, P., F., T. G., and D. R. Peterson. 1999. Riparian forest restoration along large rivers: initial results from the Sacramento River project. *Restoration Ecology* 7:360-368.
- Andr n, H. 1992. Corvid density and nest predation in relation to forest fragmentation: a landscape perspective. *Ecology* 73:794-804.
- Andr n, H. 1994. Effects of habitat fragmentation on birds and mammals in landscapes with different proportions of suitable habitat: a review. *Oikos* 71:355-366.
- Assembly Bill No. 242. 1999. Introduced by Assembly Member Thomson (Coauthors: Assembly Members Alquist, Jackson, and Oller. California Legislature, 1999-2000 Regular Session.
- Askins, R. 2000. Restoring North America's birds: lessons from landscape ecology. Yale University Press.
- Axelrod, D. I. 1988. Outline history of California vegetation. Pp. 19-194 *in* Barbour, Michael G., and Jack Major (eds). *Terrestrial Vegetation of California*. California Native Plant Society, Special Publication Number 9.
- Barbour, M., B. Pavlik, F. Drysdale, and S. Lindstrom. 1993. California's changing landscapes. California Native Plant Society, Sacramento, California.
- Barbour, M. G., and J. Major (eds). 1988. *Terrestrial Vegetation of California*. California Native Plant Society, Special Publication Number 9.
- Barnhart, S. J., J. R. McBride, and P. Warner. 1996. Invasion of northern oak woodlands by *Pseudotsuga menziesii* (Mirb.) Franco in the Sonoma Mountains of California. *Madro o* 43:28-45.

- Barrett, R.H. 1980. Mammals of California oak habitats – management implications. Pp. 275-291 *in* Proceedings of the Symposium on the Ecology, Management, and Utilization of California Oaks. June 26-28. 1979. USDA Forest Service General Technical Report PSW-44.
- Bauer, H.L. 1930. Vegetation of the Tehachapi Mountains, California. *Ecology* 11:263-280.
- Belsky, A.J., A. Matzke, and S. Uselman. 1999. Survey of livestock influences on stream and riparian ecosystems in the western United States. *Journal of Soil and Water Conservation* 54:419-431.
- Bernhardt, E. A., and T. J. Swiecki. 1997. Effects of cultural inputs on survival and growth of direct seeded and naturally occurring valley oak seedlings on hardwood rangeland. Pp. 301-311 *in* Pillsbury et al. Proceedings of a symposium on oak woodlands: ecology, management, and urban interface issues. Gen. Tech. Rep. PSW-GTR-160.
- Biosystems Analysis, Inc. 1994. Life on the Edge: a Guide to California's Endangered Natural Resources. Heyday Books, Berkeley, CA and BioSystems Books, Santa Cruz, CA.
- Biswell, H. 1989. Prescribed burning in California wildlands vegetation management. University of California Press, Berkeley.
- Bliss, S. 1998. Liquid gold, one man's view on the corporatization of wine country. Sonoma County Independent, January 22-28, 1998.
- Block, W. M. 1989. Spatial and temporal patterns of resource use by birds in California oak woodlands. Berkeley: University of California; 364 pp. Unpublished Ph.D. dissertation.
- Block, W. M., M. L. Morrison, and J. Verner. 1990. Wildlife and oak interdependency. *Fremontia* 18:72-76.
- Block, W. M., and M. L. Morrison. 1987. Conceptual framework and ecological considerations for the study of birds in oak woodlands. Pp. 163-173 *in* Proceedings of the symposium on multiple-use management of California's hardwood resources. Gen Tech. Rep. PSW-GTR-100.
- Block, W. M., and M. L. Morrison. 1991. Influence of scale on the management of wildlife in California oak woodlands. Pp. 96-104 *in* Standiford, Richard B. (technical coordinator). Proceedings of the symposium on oak woodlands and hardwood rangeland management. Gen. Tech. Rep. PSW-GTR-126.
- Block, W. M., and M. L. Morrison. 1998. Habitat relationships of amphibians and reptiles in California oak woodlands. *Journal of Herpetology* 32:51-60.
- Bock, C. E., and J. H. Bock. 1974. Geographical ecology of the Acorn Woodpecker: diversity versus abundance of resources. *American Naturalist* 108:694-698.

- Bolsinger, C. L. 1988. The hardwoods of California's timberlands, woodlands, and savannas. Resour. Bull. PNW-RB-148. Portland, OR: Pacific Northwest Research Station, Forest Service, U.S. Department of Agriculture; 148 pp.
- Bonnicksen, T. M. 2000. America's Ancient Forests, from the Ice Age to the Age of Discovery. John Wiley and Sons, Inc., New York. 594 pp.
- Borchert, M. 1990. From acorn to seedling: a perilous stage. *Fremontia* 18:3-37.
- Brantingham, B. 1998. Roots to deep when it comes to our oaks. Santa Barbara News-Press, January 4, 1998.
- Brasier, C.M. 1996. *Phytophthora cinnamomi* and oak decline in southern Europe. Environmental constraints including climate change. *Ann. Sci. For.* 53:347-358.
- Brasier, C.M., D.E.L. Cooke, and J.M. Duncan. 1999. Origin of a new *Phytophthora* pathogen through interspecific hybridization. *Proc. Natl. Acad. Sci.* 96:5878-5883.
- Brooks, C. N., and A. M. Merenlender. 2001. Determining the pattern of oak woodland regeneration for a cleared watershed in northwest California: a necessary first step for restoration. *Restoration Ecology* 9:1-12.
- Brown, R. W., and F. W. Davis. 1991. Historical mortality of valley oak (*Quercus lobata*, Née) in the Santa Ynez Valley, Santa Barbara County, 1938-1989. Pp. 202-207 *in* Standiford, R. B. (technical coordinator). Proceedings of the symposium on oak woodlands and hardwood rangeland management. Gen. Tech. Rep. PSW-GTR-126.
- Burns, M. 1998a. Group takes initiative route to protect oaks. Santa Barbara News-Press, April 1, 1998.
- Burns, M. 1998b. High-stakes wrangle; vanishing oak woodlands have prompted competing proposals to stem the decline. Can common ground be found before it's too late? Santa Barbara News-Press, April 4, 1998.
- Burns, M. 1999. New vineyard vows to respect land, oaks. Santa Barbara News-Press. May 17.
- Byrne, R., E. Edlund, and S. Mensing. 1991. Holocene changes in the distribution of oaks in California. USDA Forest Service Gen. Tech Rep PSW-126:182-188.
- Callaway, R. M. 1992a. Morphological and physiological responses of three California oak species to shade. *Int. J. Plant Sci.* 153:434-441.
- Callaway, R. M. 1992b. Effect of shrubs on recruitment of *Quercus douglasii* and *Quercus lobata* in California. *Ecology* 73:2118-2128.
- Callaway R. M., and F. W. Davis. 1998. Recruitment of *Quercus agrifolia* in central California: the importance of shrub-dominated patches. *J. Veg. Sci.* 9: 647-656.

- CEC (Commission for Environmental Cooperation). 1998. A proposed framework for delineating ecologically-based planning, implementation, and evaluation units for cooperative bird conservation in the U.S.
- Cech, T. L. 1998. *Phytophthora* decline of alder (*Alnus* spp.) in Europe. *Journal of Arboriculture* 24:339-342.
- Cicero, C. 2000. Oak Titmouse/Juniper Titmouse. *In* The Birds of North America, No. 485 (A. Poole and F. Gill, eds.). The Academy of Natural Sciences, Philadelphia, and The American Ornithologists' Union, Washington D.C.
- Coleman, J. S., S. A. Temple and S. R. Craven. 1997. Cats and wildlife: A conservation dilemma. Cooperative Extension Publications, Room 170, 630 W. Mifflin Street, Madison, WI 53703, 608-262-3346.
- Dale, V.H., S. Brown, R.A. Haeuber, N.T. Hobbs, N. Huntly, R.J. Naiman, W.E. Riebsame, M.G. Turner, and T.J. Valone. 2000. Ecological principles and guidelines for managing the use of land. *Ecological Applications* 10:639-670.
- Davis, F. W., and W. Kuhn. In press. Mapping and modeling the current and potential distribution of Valley oak in northern Santa Barbara, California. *In* Proceedings of the fifth symposium on oak woodlands: oaks in California's changing landscape. Gen. Tech. Rep. PSW-GTR-XXX. (<http://danr.ucop.edu/ihrmp/symposium.html>)
- Davis, F. W., and D. M. Stoms. 1996. Sierran vegetation: a gap analysis. Sierra Nevada Ecosystem Project, Final Report to Congress, vol. II, Assessments and Scientific Basis for Management Options. University of California, Davis.
- Davis, F. W., D. M. Stoms, A. D. Hollander, K. A. Thomas, P. A. Stine, D. Odion, M. I. Borchert, J. H. Thorne, M. V. Gray, R. E. Walker, K. Warner, and J. Graae. 1998. The California Gap Analysis Project--Final Report. University of California, Santa Barbara, CA. ([http://www.biogoc.ucsb.edu/projects/gap/gap\\_rep.html](http://www.biogoc.ucsb.edu/projects/gap/gap_rep.html))
- Davis, M. A., D. W. Peterson, P. B. Reich, M. Crozier, T. Query, E. Mitchell, J. Huntington, and P. Bazakas. 2000. Restoring savanna using fire: impact on the breeding bird community. 8:30-40.
- DeSante, D. F. 1992. Monitoring Avian Productivity and Survivorship (MAPS): a sharp, rather than blunt, tool for monitoring and assessing landbird populations (in D. R. McCullough and R.H. Barrett, eds.) *Wildlife 2001: Populations*, pp. 511-521. Elsevier Applied Science. London, U.K.
- DeSante, D. F., K. M. Burton, J. F. Saracco, and B. L. Walker. 1995. Productivity indices and survival rate estimates from MAPS, a continent-wide program of constant-effort mist-netting in North America. *Journal of Applied Statistics* 22:935-947.

- DeSante, D. F. and D. K. Rosenberg. 1998. What do we need to monitor in order to manage landbirds? pp. 93-110 *in* J.M. Marzluff and R. Sallabanks (Eds.), *Avian Conservation: Research and Management*, Island Press, Washington, D.C.
- DeSante, D. F., K. M. Burton, P. Velez, and D. Froehlich. 1999a. MAPS Manual: 1999 Protocol. The Institute for Bird Populations, Point Reyes Station, CA. 49 pp.
- DeSante, D. F., D. R. O'Grady, and P. Pyle. 1999b. Measures of productivity and survival derived from standardized mist netting are consistent with observed population trends. *Bird Study* 46 (suppl.): s178-s188.
- Erwin, D.C., and O.K. Ribeiro. 1996. *Phytophthora* diseases worldwide. American Phytopathological Society, St. Paul, Minnesota.
- Ewing, R. A. 1990. How are oaks protected? What are the issues? *Fremontia* 18:83-88.
- Faber, P. (ed.). 1990. *Fremontia*. Volume 18, No. 3. July 1990. (Entire issue dedicated to California native oaks).
- Fimrite, P. 2000. Oak Fungus Has a Killer Relative, Scientists say blight in California is like disease destroying cedars in Northwest. *San Francisco Chronicle*, Sept. 23.
- Fleischner, T. L. 1994. Ecological costs of livestock grazing in western North America. *Conservation Biology* 8:629-644.
- Fricker, M. 1999. Conservation easements. *Press Democrat*, April 4.
- Fritzke, S. L. 1997. A California black oak restoration project in Yosemite Valley, Yosemite National Park, California. Pp. 281-288 *in* Pillsbury et al. Proceedings of a symposium on oak woodlands: ecology, management, and urban interface issues. Gen. Tech. Rep. PSW-GTR-160.
- Fuchs, M. A., P. G. Krannitz, A. S. Harestad, and F. L. Brunnell. 1997. Seeds that fly on feathered wings: acorn dispersal by Steller's Jays. Pp. 648-650 *in* Pillsbury et al. Proceedings of a symposium on oak woodlands: ecology, management, and urban interface issues. Gen. Tech. Rep. PSW-GTR-160.
- Gaines, D. 1979. Oak woodland. *American Birds* 33:83.
- Gardali, T., G. Ballard, N. Nur, and G. R. Geupel. 2000. Demography of a declining population of Warbling Vireos in coastal California. *The Condor* 102:601-609.
- Garrison, B. A., and R. B. Standiford. 1997. A post-hoc assessment of the impacts to wildlife habitat from wood cutting in blue oak woodlands in the northern Sacramento Valley. Pp. 411-422 *in* Pillsbury et al. Proceedings of a symposium on oak woodlands: ecology, management, and urban interface issues. Gen. Tech. Rep. PSW-GTR-160.

- Garrison, B. A., R. L. Wachs, T. A. Giles, and M. L. Triggs. 1998. Progress report: Wildlife populations and habitat attributes of montane hardwood-conifer habitat in the central Sierra Nevada. California Department of Fish and Game, Wildlife and Inland Fisheries Division, Administrative Report Number 1998-1
- George, M. R. 1991. Grazing and land management strategies for hardwood rangelands. Pp. 315-319 in R.B. Standiford (technical coordinator), Proceedings of the symposium on oak woodlands and hardwood rangeland management. Gen. Tech. Rep. PSW-GTR-126.
- Geupel, G. R. and I. G. Warkentin. 1995. Field methods for monitoring population parameters of landbirds in Mexico. *in* Conservation of Neotropical migratory birds in Mexico, M. Wilson and S. Sader (Eds.), Maine Agricultural and Forest Experiment Station Miscellaneous Publication 727, UNAM-Umaine-USFWS/NBS, Orno, Maine.
- Gordon, D. R., and K. J. Rice. 1993. Competitive effects of grassland annuals on soil water and blue oak (*Quercus douglasii*) seedlings. *Ecology* 74:68-82
- Guisti, G.A., and P.J. Tinnin (eds.). 1993. A planner's guide for oak woodlands. Publ of the Integrated Hardwood Range Management Program, Department of Forestry and Resource Management, University of California, Berkeley, pp. 104.
- Griffin, J. R. 1971. Oak regeneration in the upper Carmel Valley, California. *Ecology* 52:862-868.
- Griffin, J. R. 1976. Regeneration in *Quercus lobata* savannas, Santa Lucia Mountains, California. *American Midland Naturalist* 95:422-435.
- Griffin, J. R. 1988. Oak woodland. Pp. 383-415 *in* Barbour, Michael G., and Jack Major (eds.). Terrestrial Vegetation of California. California Native Plant Society, Special Publication Number 9.
- Griffin, J. R. and P. C. Muick. 1990. California native oaks: past and present. *Fremontia* 18:4-12.
- Griggs, T. 1990. Valley oaks: can they be saved? *Fremontia* 18:48-51.
- Griggs, T., and D. R. Peterson. 1997. Evaluation of techniques and costs for valley oak riparian forest restoration on the Sacramento River. Pp. 289-295 *in* Pillsbury et al. Proceedings of a symposium on oak woodlands: ecology, management, and urban interface issues. Gen. Tech. Rep. PSW-GTR-160.
- Grinnell, J. and A.H. Miller. 1944. The distribution of the birds of California. Pacific Coast Avifauna 27. Cooper Ornithological Club, Berkeley, CA.
- Gutierrez, R. J. and W. D. Koenig. 1978. Characteristics of storage trees used by acorn woodpecker in two California woodlands. *Journal of Forestry* 86:162-164.
- Hall, L. M., M. R. George, D. D. McCreary, and T. E. Adams. 1992. Effects of cattle grazing on blue oak seedling damage and survival. *J. of Range Man.* 45:503-506.

- Hamilton, J. G. 1997. Changing perceptions of pre-European grasslands in California. *Madroño* 44:311-333.
- Hannon, S. J., R. L. Mumme, W. D. Koenig, S. Spon, and F. A. Pitelka. 1987. Acorn crop failure, dominance, and decline in numbers in the cooperatively breeding Acorn Woodpecker. *J. Anim. Ecol.* 56:197-207.
- Hansen, A.J. and D.L. Urban. 1992. Avian response to landscape pattern: the role of species' life histories. *Landscape Ecology* 7:163-180.
- Hansen, E. M. 1999. Disease and diversity in forest ecosystems. *Australasian Plant Pathology* 28:313-319.
- Hansen, E. M., D. J. Goheen, E. S. Jules, and B. Ullian. 2000. Managing Port-Orford-Cedar and the introduced pathogen *Phytophthora lateralis*. *Plant Disease* 84:4-14.
- Harris, R. and S. D. Kocher. In press. County policies and practices for oak woodland conservation in the Sierra Nevada. *In* Proceedings of the fifth symposium on oak woodlands: oaks in California's changing landscape. Gen. Tech. Rep. PSW-GTR-XXX. (<http://danr.ucop.edu/ihrmp/symposium.html>)
- Hastings, M. S., S. Barnhart, and J. R. McBride. 1997. Restoration management of northern oak woodlands. Pp. 275-279 *in* Pillsbury et al. Proceedings of a symposium on oak woodlands: ecology, management, and urban interface issues. Gen. Tech. Rep. PSW-GTR-160.
- Healy, W. M., A. M. Lewis, and E. F. Boose. 1999. Variation of red oak acorn production. *Forest Ecology and Management* 116:1-11.
- Holland, R.F. 1986. Preliminary descriptions of the terrestrial natural communities of California. State of California, Department of Fish and Game. Sacramento, California.
- Holmes, T. 1996a. Restoring oak populations part I: the acorn harvest. *Fremontia* 24:20-22.
- Holmes, T. 1996b. Restoring oak populations part II: acorn storage and germination. *Fremontia* 24:12-4.
- Holmes, A. L., G. R. Geupel, and G. Ballard. 1998. Distribution, abundance, and diversity of songbirds on watershed lands managed by the Marin Municipal Water District. Point Reyes Bird Observatory Report.
- Hooge, P.N. 1989. Movement patterns and nest site selection in the cooperatively breeding Acorn Woodpecker *Melanerpes formicivorus*. Masters's thesis, Univ. of California, Berkeley.
- Huntsinger, L., J.W. Bartolome, and F. F. Starrs. 1991. A comparison of management strategies in the oak woodland of Spain and California. Pp. 300-306 *in* R.B. Standiford (tech.

- coord.) Proceedings of the symposium on oak woodlands and hardwood rangeland management. USFS PSW Research Station, General Technical Report, PSW-GTR-126.
- Huntsinger, L., and R. B. Standiford. 1990. Saving someone else's oaks. *Fremontia* 18:89-95.
- Jackson, R. D., K. O. Fulgham, and B. Allen-Diaz. 1998. *Quercus garryana* Hook. (Fagaceae) stand structure in areas with different grazing histories. *Madroño* 45:275-282.
- Jansen, H. C., R. R. Snow, G. A. Treber, and F. L. Bell. 1997. Effects of livestock grazing on blue oak saplings. Pp. 313-320 *in* Pillsbury et al. Proceedings of a symposium on oak woodlands: ecology, management, and urban interface issues. Gen. Tech. Rep. PSW-GTR-160.
- Johannessen, C. L., W. A. Davenport, A. Millet, and S. McWillias. 1971. The vegetation of the Willamette Valley. *Annals of the Association of American Geographers* 61:286-302.
- Johnson, M. D., and G. R. Geupel. 1996. The importance of productivity to the dynamics of a Swainson's Thrush population. *Condor* 98:133-141.
- Johnson, S. G. Wildlife among the oaks, a management guide for landowners. Integrated Hardwood Range Management Program publication.
- Johnson, S. G. Living among the oaks, a management guide for landowners. University of California Cooperative Extension, Natural Resources Program publication.
- Johnson, S. 1990. The California Oak Foundation: a leap into action. *Fremontia* 18:103-104.
- Johnston, V. R. 1994. California forests and woodlands, a natural history. University of California Press, Berkeley.
- Juste, N. E. 1981. Deciduous oak woodland. *American Birds* 35:88.
- Kaul, R. B. 1986. Evolution and reproductive biology of inflorescences in *Lithocarpus*, *Castanopsis*, *Castanea*, and *Quercus* (Fagaceae). *Ann. Missouri Bot. Gard.* 73:284-296.
- Keator, G. 1998. The life of an oak, an intimate portrait. Heyday Books, California Oak Foundation, Berkeley. 256 pp.
- Knight, R. L. 1999. Private lands: the neglected geography. *Conservation Biology* 13:223-224.
- Koenig, W. D. 1990. Oaks, acorns and the acorn woodpecker. *Fremontia* 18:77-79.
- Koenig, W. D., and J. Haydock. 1999. Oaks, acorns, and the geographical ecology of acorn woodpeckers. *J. of Biogeography* 26:159-165.
- Koenig, W. D., P. N. Hooge, M. T. Stanback, J. Haydock. 2000. Natal dispersal in the cooperatively breeding Acorn Woodpecker. *Condor* 102: 492-502

- Koenig, W. D., and J. H.H. Knops. 1997. Patterns of geographic synchrony in growth and reproduction of oaks within California and beyond. Pp. 101-108 *in* Pillsbury et al. Proceedings of a symposium on oak woodlands: ecology, management, and urban interface issues. Gen. Tech. Rep. PSW-GTR-160.
- Koenig, W. D. and R. L. Mumme. 1987. Population ecology of the cooperatively breeding Acorn Woodpecker. Princeton Univ. Press, Princeton, NJ.
- Koenig, W. D., R. L. Mumme, W. J. Carmen, and M. T. Stanback. 1994. Acorn production by oaks in central coastal California: variation within and among years. *Ecology* 75:99-109.
- Koenig, W. D. and Stacey, P. B. 1990. Acorn woodpeckers: group-living and food storage under contrasting ecological conditions. *In* Cooperative breeding in birds: long-term studies of ecology and behavior (eds. P. B. Stacey and W. D. Koenig), pp. 413-53. Cambridge University Press, Cambridge.
- Koenig, W. D., P.B. Stacey, M.T. Stanback, and R.L. Mumme. 1995. Acorn Woodpecker (*Melanerpes formicivorus*). *In* The Birds of North America, No. 194 (A. Poole and F. Gill, eds.) The Academy of Natural Sciences, Philadelphia, and The American Ornithologists' Union, Washington, D.C.
- Krieger, L. M. 2000. Vanishing oaks, new fungus killing thousands of majestic trees along coast. *San Jose Mercury News*, August 1, 2000.
- Kuchler, A.W. 1976. Potential Natural Vegetation of California (Map 1:1,000,000). American Geographical Society, New York.
- Kus, B. 1999. Impacts of Brown-headed Cowbird parasitism on productivity of the endangered Least Bell's Vireo. *Studies in Avian Biology* 18:160-166.
- Lambeck, R. J. 1997. Focal species: a multi-species umbrella for nature conservation. *Conservation Biology* 11: 849-856.
- Larsen, D. R., and P. S. Johnson. 1998. Linking the ecology of natural oak regeneration to silviculture. *Forest Ecology and Management* 106:1-7.
- Larson, C. 1999. Vineyard development turns environmentalist heads; the best defense against possible offense. *Wine Business Monthly*. May 1999.
- Leider, A. In press. Balancing oak protection with farming flexibility: lessons from Santa Barbara County (abstract). *In* Proceedings of the fifth symposium on oak woodlands: oaks in California's changing landscape. Gen. Tech. Rep. PSW-GTR-XXX. (<http://danr.ucop.edu/ihrmp/symposium.html>)
- Ligon, J.D. and P.B. Stacey. 1996. Land use, lag times and the detection of demographic change: the case of the Acorn Woodpecker. *Conservation Biology* 10:840-846.

- Little, C. E. 1995. The dying of the trees, the pandemic in America's forests. Viking, New York.
- Mac, M. J., P. A. Opler, C. E. Puckett Haecker, and P. D. Doran. 1998. Status and trends of the nation's biological resources. 2 Vols. U.S. Department of the Interior, U.S. Geological Survey, Reston, Va.
- MacArthur, R.H. and E.O. Wilson. 1967. The theory of island biogeography. Princeton University Press, Princeton, NJ.
- Mack, R. N., D. Simberloff, W. M. Lonsdale, H. Evans, M. Cout, and F. A. Bazzaz. 2000. Biotic invasions: causes, epidemiology, global consequences, and control. *Ecological Applications* 10:689-710.
- MacRoberts, M. H. and B. R. MacRoberts. 1976. Social organization and behavior of the Acorn Woodpecker in central coastal California. *Ornithol. Monogr.* 21: 1-115.
- Martin, G. 1986. Behind the scenes. *The Nature Conservancy News* 10/11 1986:18-23.
- Martin, J. W. and J. R. Parrish. 2000. Lark sparrow (*Chondestes grammacus*). In *The Birds of North America*, No. 488 (A. Poole and F. Gill, Eds.). The Birds of North America, Philadelphia, PA.
- Martin, T. E. 1995. Summary: model organisms for advancing and understanding of ecology and land management, pp. 477-484, in Martin, T. E. and D. M. Finch (Eds.), *Ecology and management of Neotropical migratory birds: a synthesis and review of critical issues*. Oxford University Press.
- Martin, T. E. and G. R. Geupel. 1993. Nest monitoring plots: Methods for locating nests and monitoring success. *J. Field. Ornith.* 64: 507-519.
- Martin, T. E. C. Paine, C.J. Conway, W.M. Hochachka, P. Allen and W. Jenkins. 1997. The Breeding Biology Research and Monitoring Database (BBIRD) Field Protocol. Univ. Of Montana Coop. Unit, Unpublished manual.
- May, M. A., and P. J. Peters. 1979. Oak woodland. *American Birds* 33:83-84.
- Mayer, K. E. and W. F. Laudenslayer, Jr., eds. 1988. A guide to the wildlife habitats of California. State of California, The Resources Agency, Department of Forestry and Fire Protection, Sacramento, CA.
- McBride, J. R., and A. Mossaegh. 1990. Will climate change affect our oak woodlands? *Fremontia* 18:55-57.

- McCarthy, H. 1993. Managing oaks and the acorn crop. Pp. 213-228 in Blackburn, T. C. and K. Anderson (Eds.). *Before the wilderness, environmental management by native Californians*. Ballena Press, Menlo Park, California.
- McCreary, D. D. How to grow California oaks. Integrated Hardwood Range Management Program.
- McCreary, D. D. 1990. Native oaks – the next generation. *Fremontia* 18:44-47.
- McCreary, D. D. 2001. Regenerating Rangeland Oaks in California. University of California Agricultural & Natural Resources Publication 21601. Oakland, CA.
- McCreary, D. D., and J. Tecklin. 1997. Effects of seedling protectors and weed control on blue oak growth and survival. Pp. 243-250 in Pillsbury et al. *Proceedings of a symposium on oak woodlands: ecology, management, and urban interface issues*. Gen. Tech. Rep. PSW-GTR-160.
- McDonald, P.M. 1990b. *Quercus kelloggii* Newb. California black oak. Pages 661-671 in *Silvics of North America*. Vol 2, Hardwoods edited by R.M. Burns and B.H. Honkala. USDA Forest Service, Washington DC Agriculture Handbook 654. 877 pages.
- McKibben, L. A., and W. C. Graves. 1987. Managing blue oak for wildlife based on acorn production. Pp 227-229 in *Proceedings of the symposium on multiple-use management of California's hardwood resources*. Gen Tech. Rep. PSW-GTR-100.
- McShea, W. J. 2000. The influence of acorn crops on annual variation in rodent and bird populations. *Ecology* 81:228-238.
- McShea, W. J. and G. Schwede. 1993. Variable acorn crops: response of white-tailed deer and other mast consumers. *Journal of Mammalogy* 74:999-1006.
- Mensing, S. 1990. Blue oak regeneration in the Tehachapi Mountains. *Fremontia* 18:38-41.
- Merenlender, A. M., and J. Crawford. 1998. Vineyards in an oak landscape. Publication of the Integrated Hardwood Range Management Program, University of California, Berkeley.
- Merenlender, A. M., K. L. Heise, and C. Brooks. 1998. Effects of subdividing private property on biodiversity in California's north coast oak woodlands. *Trans. Westerns Section of the Wildlife Society* 34:9-20.
- Miller, C. 2000. Scientists fear for Sierra oaks in deadly tree infestation. *The Sacramento Bee*, August 1, 2000.
- Mircetich, S. M., R.N. Campbell, and M.E. Matheron. 1977. *Phytophthora* trunk canker of coast live oak and cork oak trees in California. *Plant Disease Reporter* 61:66-70.

- Momen, B., J. W. Menke, J. M. Welker, K. J. Rice, and F. S. Chapin III. 1994. Blue-oak regeneration and seedling water relations in four sites within a California oak savanna. *Int. J. Plant Sci.* 155:744-749.
- Morris, D. L., and F. R. Thompson III. 1998. Effects of habitat and invertebrate density on abundance and foraging behavior of Brown-headed Cowbirds. *Auk* 115: 376-385.
- Morrison, M. L., L. S. Hall, S. K. Robinson, S. I. Rothstein, D. C. Hahn, and T. D. Rich. 1999. Research and management of the Brown-headed Cowbird in Western landscapes. *Studies in Avian Biology* 18.
- Muick, P. 1990. Valley oak restoration at Brown's Farm, eleven years later. *Fremontia* 18:53-54.
- Muick, P. C., J. Stewart, and D. Jensen. 1990. A CNPS oak-hardwood policy. *Fremontia* 18:101-102.
- Muick, P. C. 1997. Effects of shade and clipping on coast live and blue oak seedling mortality and growth in California annual grasslands. Pp. 135-145 *in* Pillsbury et al. Proceedings of a symposium on oak woodlands: ecology, management, and urban interface issues. Gen. Tech. Rep. PSW-GTR-160.
- Mummert, D. P., L. Baines, and W. D. Tietje. In press. Cavity nesting bird use of Bluebird nest boxes in vineyards of central-coastal California. *In* Proceedings of the fifth symposium on oak woodlands: oaks in California's changing landscape. Gen. Tech. Rep. PSW-GTR-XXX. (<http://danr.ucop.edu/ihrmp/symposium.html>)
- Noss, R. F. (ed.). 2000. The redwood forest, history, ecology, and conservation of the coast redwoods. Island Press, Washington, D.C.
- Noss, R. F., E.T. LaRoe, and J.M. Scott. 1995. Endangered ecosystems of the United States: a preliminary assessment of loss and degradation. Biological Report 28. Washington DC: USDA National Biological Service.
- Nur, N., G. R. Geupel, and S. L. Jones. 1999. A statistical guide to data analysis of avian population monitoring Programs. U.S. Department of Interior, Fish and Wildlife Service, BTP-R6001-1999, Washington, D.C.
- Ostfeld, R. S., C. G. Jones, and J. O. Wolf. 1996. Of mice and mast, ecological connections in eastern deciduous forests. *BioScience* 46:323-330.
- Palkovsky, N. and P. Svihra. 2000. Homeowner's Guide to Sudden Oak Death in Marin County University of California Cooperative Extension. (<http://cemarin.ucdavis.edu/pdf/%20files/homeownersguide.pdf>)
- Parikh, A., and N. Gale. 1998. Coast live oak revegetation on the central coast of California. *Madrõno* 45:301-309.

- Pavlik, B. M., P. C. Muick, S. Johnson, and M. Popper. 1991. Oaks of California. Cachuma Press, Los Olivos.
- Phillips, R. L., N. K. McDougald, R. B. Standiford, D. D. McCreary, and W. E. Frost. 1997. Blue oak regeneration in southern Sierra Nevada foothills. Pp. 177-181 *in* Pillsbury et al. Proceedings of a symposium on oak woodlands: ecology, management, and urban interface issues. Gen. Tech. Rep. PSW-GTR-160.
- Pillsbury, N. H., J. Verner, W. D. Tietje (technical coordinators). 1997. Proceedings of a symposium on oak woodlands: ecology, management, and urban interface issues. Gen. Tech. Rep. PSW-GTR-160. Albany, CA. Pacific Southwest Research Station, Forest Service, U.S. Dept. of Agriculture, 78 pp.
- Piirto, D. D., B. Smith, E. K. Huff, and S. T. Robinson. 1997. Efficacy of herbicide application methods used to control tanoak (*Litocarpus densiflorus*) in an uneven-aged coast redwood management context. Pp. 199-208 *in* Pillsbury et al. Proceedings of a symposium on oak woodlands: ecology, management, and urban interface issues. Gen. Tech. Rep. PSW-GTR-160.
- Plumb, T. R., and M. D. De Lasaux. 1997. An evaluation of coast live oak regeneration techniques. Pp. 231-242 *in* Pillsbury et al. Proceedings of a symposium on oak woodlands: ecology, management, and urban interface issues. Gen. Tech. Rep. PSW-GTR-160.
- Purcell, K. L. 1995. Reproductive strategies of open-and cavity-nesting birds. Reno: University of Nevada; 110 pp. Ph.D. dissertation.
- Purcell, K. L., and J. Verner. 1998. Density and reproductive success of California Towhees. *Conservation Biology* 12:442-450.
- Purcell, K. L., and J. Verner. 1999. Nest predators of open and cavity nesting birds in oak woodlands. *Wilson Bull.* 111:251-256.
- Purcell, K. L., J. Verner, and S. R. Mori. In press. Factors affecting the abundance and distribution of European Starlings at the San Joaquin Experimental Range. *In* Proceedings of the fifth symposium on oak woodlands: oaks in California's changing landscape. Gen. Tech. Rep. PSW-GTR-XXX. (<http://danr.ucop.edu/ihrmp/symposium.html>)
- Raabe, R. D. 1990. Diseases of native oaks of California. *Fremontia* 18:64-67
- RAC (Resources Agency of California). 1998. Preserving California's natural heritage. A bioregional guide to land and water conservation. Revised edition.
- Ralph, C. J., G. R. Geupel, P. Pyle, T. E. Martin, and D. F. DeSante. 1993. Field Methods for Monitoring Landbirds. USDA Forest Service Publication, PSW-GTR 144, Albany, CA.

- Ralph, C. J., J. R. Sauer and S. Droege. 1995. Monitoring bird populations by point counts. USDA Forest Service Publication, PSW-GTR 149, Albany CA.
- Reich, P. B., M. D. Abrams, D. S. Ellsworth, E. L. Kruger, and T. J. Tabone. 1990. Fire affects ecophysiology and community dynamics of central Wisconsin oak forest regeneration. *Ecology* 71:2179-2190.
- RHJV (Riparian Habitat Joint Venture). 2000. Version 1.0. The riparian bird conservation plan: a strategy for reversing the decline of riparian associated birds in California. California Partners in Flight. <http://www.prbo.org/calpif/>
- Ricketts, T. H. E. Dinerstein, D. M. Olson, and C. J. Loucks, et al. 1999. Terrestrial ecoregions of North America, a conservation assessment. Island Press, Washington, D.C.
- Ritter, J. 2000. In California, oaks suddenly 'bleed' then die. USA Today, Friday June 16, 2000.
- Robbins, C. S. 1970. Recommendations for an international standard for a mapping method in bird census work. *Aud. Field Notes* 24:723-726.
- Robin, C., M.-L. Desprez Loustau, and C. Delatour. 1992. Factors influencing the enlargement of trunk cankers of *Phytophthora cinnamomi* in red oak. *Can. J. For. Res.* 22:367-374.
- Rogers, R., and P. S. Johnson. 1998. Approaches to modeling natural regeneration in oak-dominated forests. *Forest Ecology and Management* 106:45-54.
- Rosenstock, S. S. 1998. Influence of Gambel oak on breeding birds in ponderosa pine forests of northern Arizona. *Condor* 100:485-492.
- Rossi, R.S. 1979. Land use and vegetation change in the oak woodland-savanna of northern San Luis Obispo County, California (1774-1978). Unpubl. Ph.D. Dissertation. Univ. Calif., Berkeley. 337 pp.
- Rossi, R. 1990. Oak ordinances: do they help or hurt? *Fremontia* 18:96-98.
- Sage, R. 1998a. Oaks vs. vineyards – the missing voice of science. Santa Barbara News-Press, March 15, 1998.
- Sage, R. 1998b. Trading oaks for wine in Santa Barbara County. *Wildflower*, Winter 1998; pp. 16-19.
- Sauer, J.R., J.E. Hines, I. Thomas, J. Fallon, and G. Gough. 2000. The North American Breeding Bird Survey, Results and Analysis 1966-1991. Version 98.1, USGS Patuxent Wildlife Research Center, Laurel, MD. <http://www.mbr-pwrc.usgs.gov/bbs/>
- Sawyer, J. O., and T. K. Keeler-Wolf. 1995. A manual of California vegetation. California Native Plant Society. Sacramento, California: 471pp. Also available on line at: <http://davisherb.ucdavis.edu/CNPSActiveServer/front.html>

- Schwan, J., H. Fong, and H. K. Hug. 1997. Wildfire and oak regeneration at the urban fringe. Pp. 559-564 in Pillsbury et al. Proceedings of a symposium on oak woodlands: ecology, management, and urban interface issues. Gen. Tech. Rep. PSW-GTR-160.
- Scott, T. A. 1993. Initial effects of housing construction on woodland birds along the wildland urban interface. Pp. 181-187 in J. E. Keeley (ed), Interface Between Ecology and Land Development in California, Southern California Academy of Sciences, Los Angeles.
- Siegel, R. B. and D. F. DeSante. 1999. Draft Avian Conservation Plan for the Sierra Nevada Bioregion: A Report to California Partners in Flight. Institute for Bird Populations.
- SNF (Sierra Nevada Framework). April 2000. Sierra Nevada Forest Plan Amendment, Draft Environmental Impact Statement. USDA Forest Service Pacific Southwest Region.
- Sinton, S. 1999. A new tool for conserving oak woodlands: the California Rangeland Trust. *Oaks 'n' folks* 14:1-2.
- Sisk, T. D., N. M. Haddad, and P. R. Ehlich. 1997. Bird assemblages in patchy woodlands: modeling the effects of edge and matrix habitats. *Ecological Applications* 7:1170-1180.
- Small, A. 1994. California birds: Their status and distribution. Ibis Publishing Co. Vista, CA. 342 pp.
- Söderström, B., T. Pärt, and J. Rydén. 1998. Different nest predator faunas and nest predation risk on ground and shrub nests at forest ecotones: an experiment and a review. *Oecologia* 117:108-118.
- Sork, V. L., and J. Bramble. 1993. Ecology of mast-fruited in three species of North American deciduous oaks. *Ecology* 74:528-541.
- Soulé, M.E., D.T. Bolger, A.C. Alberts, R. Sauvajot, J. Wright, M. Soric, and S. Hill. 1988. Reconstructed dynamics of rapid extinctions of chaparral-requiring birds in urban habitat islands. *Conservation Biology* 2:75-92.
- Stacy, P.B., and J.D. Ligon 1987. Territory quality and dispersal options in the Acorn Woodpecker, and a challenge to the habitat-saturation model of cooperative breeding. *Am. Nat.* 130:654-676.
- Stallcup, R. 1991. Cats: a heavy toll on songbirds, a reversible catastrophe. *The Observer*, No. 91, Spring/Summer. Point Reyes Bird Observatory. Stinson Beach, CA.
- Standiford, R.B., tech. coord. 1991. Proceedings of the symposium on oak woodlands and hardwood rangeland management; 1990; Gen. Tech. Rep. PSW-126. Pacific Southwest Research Station, USDA Forest Service, Berkeley, CA.



- Standiford, R. 2000. A strategic research plan, University of California Division of Agriculture and Natural Resources: Evaluation of Tanoak, Coast Live Oak and Black Oak mortality syndrome "Sudden Oak Death". A report to the California Board of Forestry.
- Standiford, R., and P. Tinnin (eds.). 1996. Guidelines for Managing California's Hardwood Rangelands. Publication of the Integrated Hardwood Range Management Program, University of California, Berkeley.
- Standiford, R. B., and J. Bartolome. 1997. The Integrated Hardwood Range Management Program: education and research as a conservation strategy. Pp. 569-581 *in* Pillsbury et al. Proceedings of a symposium on oak woodlands: ecology, management, and urban interface issues. Gen. Tech. Rep. PSW-GTR-160.
- Standiford, R., N. McDougald, W. Frost, and R. Phillips. 1997. Factors influencing the probability of oak regeneration on southern Sierra Nevada woodlands in California. *Madrono* 44:170-183.
- Stein, B. A., L. S. Kutner, and J. S. Adams (eds.). 2000. Precious heritage, the status of biodiversity in the United States. Oxford University Press, New York.
- Stephens, S. L. 1997. Fire history of a mixed oak-pine forest in the foothills of the Sierra Nevada, El Dorado County, California. Pp. 191-198 *in* Pillsbury et al. Proceedings of a symposium on oak woodlands: ecology, management, and urban interface issues. Gen. Tech. Rep. PSW-GTR-160.
- Stralberg, D. and B. Williams. 2002. Effects of Residential Development and Landscape Composition on the Breeding Birds of Placer County's Foothill Oak Woodlands. In Standiford, R.B., D. McCreary and K.L. Purcell, eds. Proceedings of the 5th Oak Symposium: Oaks in California's Changing Landscape. USDA Forest Service Gen. Tech. Rep. PSW-GTR-184.
- pp.341-366. In press. Effects of residential development and landscape composition on the breeding birds of Placer County's foothill oak woodlands. *In* Proceedings of the fifth symposium on oak woodlands: oaks in California's changing landscape. Gen. Tech. Rep. PSW-GTR-XXX. (<http://danr.ucop.edu/ihrmp/symposium.html>)
- Stromberg, M. R., and J. R. Griffin. 1996. Long-term patterns in coastal California grasslands in relation to cultivation, gophers, and grazing. *Ecological Applications* 6:1189-1211.
- Strong, G., and A. George. 1990. Visalia is saving its valley oaks. *Fremontia* 18:99-100.
- Suarez, A V., K. S. Pfennig, and S. K. Robinson. 1997. Nesting success of a disturbance-dependent songbird on different kinds of edges. *Conservation Biology* 11: 928-935.
- Svihra, P. 1999a. Tanoak and coast live oak under attack. University of California Cooperative Extension. Oaks 'n' folks 14(2): 1 (<http://danr.ucop.edu/ihrmp/oak90.htm>)

- Svihra, P. 1999b. Sudden death of tanoak, *Lithocarpus densiflorus*. University of California Cooperative Extension. Pest Alert 1: 1-2. (<http://cemarin.ucdavis.edu/pdf/%20files/pestalet1.pdf>)
- Svihra, P. 1999c. Western oak bark beetles and ambrosia beetles, killers of live oaks. University of California Cooperative Extension. Pest Alert 3: 1-4
- Svihra, P. 2000. Protection of live oaks against attacks by oak bark beetles and ambrosia beetles. University of California Cooperative Extension. Pest Alert 3B: 1-4. (<http://cemarin.ucdavis.edu/pdf/%20files/pestalet3B.pdf>)
- Sweitzer, R. A., and D. Van Vuren. In press. Effects of feral pigs on oak woodland ecosystems in California. *In* Proceedings of the fifth symposium on oak woodlands: oaks in California's changing landscape. Gen. Tech. Rep. PSW-GTR-XXX. (<http://danr.ucop.edu/ihrmp/symposium.html>)
- Swiecki, T. J. 1999. Observations on Tanoak (*Lithocarpus densiflorus*) Dieback and Mortality in Marin County, California. (<http://www.phytosphere.com/tanoak.html>)
- Swiecki, T. J., and E. Bernhardt. In press. Effects of fire on naturally occurring blue oak (*Quercus douglasii*) saplings. *In* Proceedings of the fifth symposium on oak woodlands: oaks in California's changing landscape. Gen. Tech. Rep. PSW-GTR-XXX. (<http://danr.ucop.edu/ihrmp/symposium.html>)
- Swiecki, T. J., E. A. Bernhardt, and C. Drake. 1997a. Stand-level status of blue oak sapling recruitment and regeneration. Pp. 147-156 *in* Pillsbury et al. Proceedings of a symposium on oak woodlands: ecology, management, and urban interface issues. Gen. Tech. Rep. PSW-GTR-160.
- Swiecki, T. J., E. A. Bernhardt, and C. Drake. 1997b. Factors affecting blue oak sapling recruitment. 1997. Pp. 157-167 *in* Pillsbury et al. Proceedings of a symposium on oak woodlands: ecology, management, and urban interface issues. Gen. Tech. Rep. PSW-GTR-160.
- Swiecki, T. J., and E. A. Bernhardt. 1998. Understand blue oak regeneration. *Fremontia* 26:19-26.
- Tappeiner, J. C. II., P. M. McDonald, and D. F. Roy. 1990 *Lithocarpus densiflorus* (Hook & Arn.) Rehd. Tanoak. *In* Burns, R. M., and B. H. Honkala (Technical Coordinators) Silvics of North America. Volume 2. Hardwoods. 2,877 pp. USDA Forest Service Agricultural Handbook No. 654. Washington, D.C.
- Techlin, J., J. M. Connor, and D. D. McCreary. 1997. Rehabilitation of a blue oak restoration project. Pp. 267-273 *in* Pillsbury et al. Proceedings of a symposium on oak woodlands: ecology, management, and urban interface issues. Gen. Tech. Rep. PSW-GTR-160.

- Tewksbury, J.T., S.J. Hejl and T.E. Martin. 1998. Breeding productivity does not decline with increasing fragmentation in a western landscape. *Ecology* 2890-2903.
- Thomas, J. W. 1997. California's oak woodlands: where we have been, where we are, where we need to go. Pp. 3-10 *in* Pillsbury et al. Proceedings of a symposium on oak woodlands: ecology, management, and urban interface issues. Gen. Tech. Rep. PSW-GTR-160.
- Thompson, K. 1961. Riparian forests of the Sacramento Valley, California. *American Association of American Geographers* 51:294-315.
- Tietje, W. 1990. Acorns: planning for oak-woodland wildlife. *Fremontia* 18:80-81.
- Tietje, W.D., P. H. Bloom, and J. K. Vreeland. 1997a. Characteristics of Red-tailed Hawk nest sites in oak woodlands of central California. Pp. 365-372 *in* Pillsbury et al. Proceedings of a symposium on oak woodlands: ecology, management, and urban interface issues. Gen. Tech. Rep. PSW-GTR-160.
- Tietje, W. D., W. Bremer, T. Craig, and C.M. Gallagher. 1996. Use of GIS in determining development effects on wildlife in oak woodlands. *Trans. Western Section of the Wildlife Society* 31:7-11.
- Tietje, W. D., and R. Schmidt. 1988. California's integrated hardwood range management program. Pp. 67-77 *in* R. E. McCabe (ed.) Transactions of the North American Wildlife and Natural Resources Conference; 1988 March 18-23; Louisville, KY. Vol. 53. Washington, D.C., Wildlife Management Institute.
- Tietje, W. D., and J. K. Vreeland. 1997. Vertebrates diverse and abundant in well-structured oak woodland. *California Agriculture* 51:8-14.
- Tietje, W. D., and J. K. Vreeland. In press. Numerical response of small vertebrates to prescribed fire in a California oak woodland. *In* Proceedings of the fifth symposium on oak woodlands: oaks in California's changing landscape. Gen. Tech. Rep. PSW-GTR-XXX. (<http://danr.ucop.edu/ihrmp/symposium.html>)
- Tietje, W. D., J. K. Vreeland, N. R. Siepel, and J. L. Dockter. 1997b. Relative abundance and habitat associations of vertebrates in oak woodlands in coastal-central California. Pp. 391-400 *in* Pillsbury et al. Proceedings of a symposium on oak woodlands: ecology, management, and urban interface issues. Gen. Tech. Rep. PSW-GTR-160.
- Tietje, W.D., J. K. Vreeland, and W.H. Weitkamp. 2001. Live oak saplings survive prescribed fire and sprout. *California Agriculture* 55: 18-22.
- Tiffney, B. H. 1986. Fruit and seed dispersal and the evolution of the Hamamelidae. *Annals of the Missouri Botanical Garden* 73:394-416.
- Tobin, M. 1999. Logging issues could curtail west coast vineyard expansion. *Wine Business Monthly* 55, March 1999.

- Trail, P. W. 1980. Ecological correlates of social organization in a communally breeding bird, the Acorn Woodpecker, *Melanerpes formicivorus*. *Behav. Ecol. Sociobiol.* 7:83-92.
- Troetschler, R.G. 1976. Acorn Woodpecker breeding strategy as affected by starling nest-hole competition. *Condor* 78: 151-165.
- Tu, M., Hurd, C., & J.M. Randall, 2001. Weed Control Methods Handbook, The Nature Conservancy, <http://tneweeds.ucdavis.edu>, Version: April 2001.
- Tucker, J.M. 1980. Taxonomy of California oaks. In T.R. Plumb (tech. coord.). Proceedings of the Symposium on the Ecology, Management and Utilization of California oaks. Berkeley; Pacific SW Forest and Range Experiment Station, Forest Service, USDA.
- USFWS (U. S. Fish and Wildlife Service). 1998. Draft recovery plan for the Least Bell's Vireo. U. S. Fish and Wildlife Service, Portland Oregon. 139 pp.
- Van de Kamp, M. 1996. Oaks victims of vineyard boom. *Santa Barbara News-Press*, 20 November 1996.
- Van de Kamp, M. 1997. Oaks vs. grapes. *Santa Barbara News-Press*. December 29, 1997.
- Vander Wall, S. B. 1990. Food Hoarding in Animals. University of Chicago Press, Chicago.
- Van Fleet, C. C. 1919. A short paper on the Hutton Vireo. *Condor* 21:162-165.
- Van Horne, B. 1983. Density as a misleading indicator of habitat quality. *J. of Wild. Man.* 47:893-901.
- Verner, J. 1980. Birds of California oak habitats – management implications. Pp. 246-264 *in* Proceedings of the Symposium on the Ecology, Management, and Utilization of California Oaks. June 26-28. 1979. USDA Forest Service General Technical Report PSW-44.
- Verner, J. 1987. Preliminary results from a system for monitoring trends in bird populations in oak-pine woodlands. Pp. 214-222 *in* Proceedings of the symposium on multiple-use management of California's hardwood resources. Gen. Tech. Rep. PSW-GTR-100.
- Verner, J. and K. A. Milne. 1989. Coping with sources of variability when monitoring population trends. *Ann. Zool. Fennici* 26:191-199.
- Verner, J., K. L. Purcell, and J. G. Turner. 1996. Monitoring trends in bird populations: addressing background levels of annual variability in counts. *Trans. Western Section of the Wildlife Soc.* 32:1-7.
- Verner, J., K. L. Purcell, and J. G. Turner. 1997. Bird communities in grazed and ungrazed oak-pine woodlands at the San Joaquin Experimental Range. Pp. 381-390 *in* Pillsbury et al.

- Proceedings of a symposium on oak woodlands: ecology, management, and urban interface issues. Gen. Tech. Rep. PSW-GTR-160.
- Verner, J. and K. L. Purcell. 1999. Fluctuating populations of House Wrens and Bewick's Wrens in the foothills of the western Sierra Nevada of California. *Condor*: 101:219-229.
- Verner, J. and L. V. Ritter. 1985. A comparison of transects and point counts in oak-pine woodlands of California. *Condor* 87:47-68.
- Verner, J. and L. V. Ritter. 1986. Hourly variation in morning point counts of birds. *Auk* 103: 117-124.
- Waters, J. R. 1988. Population and habitat characteristics of cavity-nesting birds in a California oak woodlands. Arcata, CA: Humboldt State University; 100 pp. M.S. Thesis.
- Watt, A.S. 1919. On the causes of failure of natural regeneration in British oakwoods. *Journal of Ecology* 7:173-203.
- Weitkamp, W.H., W.D. Tietje, and J.K. Vreeland. 2001. Brush piles and mesh cages protect blue oak seedlings from animals. *California Agriculture* 55: 23-27.
- White, K. L. 1966. Structure and composition of foothill woodland in central coastal California. *Ecology* 47:229-237.
- Williams, P. L. 1979. Deciduous oak woodland. *American Birds* 33:82-83.
- Williams, P. L. 1980. Deciduous oak woodland. *American Birds* 34:73-74.
- Wilson, R.A., P. Manley and B.R. Noon. 1991. Covariance patterns among birds and vegetating in a California Oak Woodland. Pages 126-135 *In* Proceedings of the Symposium on Oak Woodlands and Hardwood Rangeland Management, October 31-November 2, 1990 edited by R.B. Standiford. General Technical Report PSW-GTR-126. USDA Forest Service, Pacific Southwest Research Station. 376 pages.
- Wolff, J. O. 1996. Population fluctuations of mast-eating rodents are correlated with production of acorns. *Journal of Mammalogy* 77:850-856.
- Yoon, C. K. 2000. Aggressive disease killing trees in California. *New York Times*, Sunday, August 13, 2000.

## Appendix A. Resources

---

*The Oaks of California* by Pavlik et al. (1991)

### The California Oak Foundation

<http://www.californiaoaks.org/>

The California Oak Foundation (COF) is dedicated to protecting and perpetuating California's native oak woodlands and the wildlife habitat and watershed benefits they provide.

### Contact information:

California Oak Foundation  
1212 Broadway, Suite 810  
Oakland, CA 94612  
Tel: (510) 763-0282  
Fax: (510) 208-4435  
E-mail: [oakstaff@californiaoaks.org](mailto:oakstaff@californiaoaks.org)

Also available at this site: *The California Oak Report* Beginning in January 2000, our Current Issues page will feature a monthly report, which will provide information to the general public about the biological role of California's oak woodlands in the landscape and the planning processes applicable to oak woodland habitats. The column also hopes to function as an interactive forum for the discussion of oak issues and as a site for the general public to submit comments, queries, oak news, etc. Automatic monthly electronic mailings of The California Oak Report are available upon request by contacting [oakstaff@californiaoaks.org](mailto:oakstaff@californiaoaks.org).

### University of California Integrated Hardwood Range Management Program

<http://128.48.5.253/ibrmp/>

The Program's purpose is in developing alternative land use planning and range management strategies to ensure multiple use of hardwood rangelands while improving oak regeneration and maintaining diverse wildlife habitat. This site is a tremendous resource for information on anything related to oak woodlands.

### OBJECTIVES:

- Develop methods to sustain hardwood rangeland ecosystems and landscapes;
- Maintain wildlife habitat on hardwood rangelands;
- Restore degraded hardwood rangelands;
- Ensure land use planning utilizing available information to conserve hardwood rangeland ecosystems;
- Maintain economically viable private hardwood rangeland enterprises;

- Maintain statewide information base about trend, condition, and extent of hardwood rangelands; and
- Help focus public awareness about the importance of hardwood rangeland habitats.

#### The Sierra Nevada Ecosystem Project

[http://ceres.ca.gov/snep/pubs/web/v1/v1\\_default.html](http://ceres.ca.gov/snep/pubs/web/v1/v1_default.html)

Sierra Nevada Ecosystem Study (SNEP) was a congressionally mandated 3 year study of the entire Sierra Nevada range. The study was managed by the University of California Centers for Water and Wildland Resources, Davis, CA under a research agreement with the U. S. Forest Service, Pacific Southwest Research Station, Albany, CA. Posted on the above web site are final reports from this intensive study by an independent science team. Formal release of the report to Congress occurred on June 7, 1996.

#### Hastings Natural History Reservation

<http://www.hastingsreserve.org/OakStory/OakIntro.html>

Hastings is a Biological Field Station of the University of California providing the wildlands and facilities to conduct college and graduate level studies of natural systems in the Santa Lucia range in Monterey County, California. Our research reveals that every species has a fascinating story. Their stories put our lives in perspective. We hope that sharing these stories will inspire individuals to protect and appreciate whatever is still wild and under their care.

#### The Sierra Nevada Framework for Conservation and Collaboration

<http://www.r5.fs.fed.us/sncf/>

In early 1998, the USDA Forest Service Pacific Southwest Region, the Pacific Southwest Research Station and the Intermountain Region renewed their efforts to work with tribes, county governments, state and federal agencies, interest groups and individuals interested in improving the health of Sierra Nevada ecosystems and communities. The effort integrates recent science into natural resource management through a variety of approaches and at a variety of geographic scales. It also works toward more effective means of coordination, cooperation and collaboration among the various parties.

The Sierra Nevada Forest Plan Amendment Environmental Impact Statement is one of several Framework activities. At this site, you will find links to several other projects and activities going on in the Framework. The Design Paper outlines many of the commitments the Forest Service is making as part of its contribution toward improving natural resource management and collaboration among tribes, agencies, local governments and citizens.

#### US Department of Agriculture—Natural Resources Conservation Service Programs

While there are a variety of USDA programs available to assist people with their conservation needs, the following primarily financial assistance programs are the principal programs available. Locally led conservation groups are encouraged to contact the State offices of the appropriate agency for specific information about each program.

For more information about any of the following NRCS programs: <http://www.nrcs.usda.gov/>

Natural Resources Conservation Service  
Attn: Conservation Communications Staff  
P.O. Box 2890  
Washington, DC 20013

#### Forestry Incentives Program

<http://www.nhq.nrcs.usda.gov/CCS/FB96OPA/FBillLnk.html>

The 1996 Farm Bill extends the Forestry Incentives Program (FIP), which was originally authorized in 1978 to share up to 65 percent of the costs of tree planting, timber stand improvements, and related practices on non-industrial private forest lands FIP's forest maintenance and reforestation provide numerous natural resource benefits, including reduced wind and soil erosion and enhanced water quality and wildlife habitat as well as helping to assure a reliable future supply of timber. Improving timber stands, which help to sequester greenhouse gases, also contributes to the President's Climate Change initiative. FIP is administered by the U.S. Department of Agriculture's (USDA) Natural Resources Conservation Service (NRCS) and Forest Service.

#### Program Availability

FIP is a nationwide program available in counties designated on the basis of a Forest Service survey of total eligible private timber acreage that is potentially suitable for production of timber products. Federal cost-share money is available-with a limit of \$10,000 per person per year with the stipulation that no more than 65 percent of the cost may be paid. To find out if your county participates in FIP, check with your local USDA office, State forester, conservation district, or Cooperative Extension office.

#### The Wildlife Habitat Incentives Program (WHIP)

<http://www.nhq.nrcs.usda.gov/PROGRAMS/Animals/whip/index.htm>

A voluntary program for people who want to develop and improve wildlife habitat primarily on private lands. It provides both technical assistance and cost-share payments to help establish and improve fish and wildlife habitat.

Participants who own or control land agree to prepare and implement a wildlife habitat development plan. The U.S. Department of Agriculture's (USDA) Natural Resources Conservation Service (NRCS) offers participants technical and financial assistance for the establishment of wildlife habitat development practices. In addition, if the landowner agrees, cooperating State wildlife agencies and nonprofit or private organizations may provide expertise or additional funding to help complete a project.

**Conservation Technical Assistance (CTA)**

The purpose of the program is to assist land-users, communities, units of state and local government, and other Federal agencies in planning and implementing conservation systems. The purpose of the conservation systems are to reduce erosion, improve soil and water quality, improve and conserve wetlands, enhance fish and wildlife habitat, improve air quality, improve pasture and range condition, reduce upstream flooding, and improve woodlands.

**Conservation Reserve Program (CRP)**

The Conservation Reserve Program reduces soil erosion, protects the Nation's ability to produce food and fiber, reduces sedimentation in streams and lakes, improves water quality, establishes wildlife habitat, and enhances forest and wetland resources. It encourages farmers to convert highly erodible cropland or other environmentally sensitive acreage to vegetative cover, such as tame or native grasses, wildlife plantings, trees, filterstrips, or riparian buffers. Farmers receive an annual rental payment for the term of the multi-year contract. Cost sharing is provided to establish the vegetative cover practices.

**US Fish and Wildlife Service—Partners for Fish and Wildlife**

The mission of the U.S. Fish and Wildlife Service is, by working with others, to conserve, protect, and enhance fish and wildlife and their habitats for the continuing benefit of the American people. The Service's Partners for Fish and Wildlife program, formerly named the Partners for Wildlife program, helps accomplish this mission by offering technical and financial assistance to private (non-federal) landowners to voluntarily restore wetlands and other fish and wildlife habitats on their land. The program emphasizes the reestablishment of native vegetation and ecological communities for the benefit of fish and wildlife in concert with the needs and desires of private landowners.

For more information about any of the following US Fish and Wildlife programs:

<http://partners.fws.gov/index.htm>

Partners for Fish and Wildlife  
State Coordinator  
2800 Cottage Way W-2610  
Sacramento, CA 95825  
916-414-6446

The assistance that the U.S. Fish and Wildlife Service offers to private landowners may take the form of informal advice on the design and location of potential restoration projects, or it may consist of designing and funding restoration projects under a voluntary cooperative agreement with the landowner. Under the cooperative agreements, the landowner agrees to maintain the restoration project as specified in the agreement for a minimum of 10 years.

Restoration projects may include, but are not limited to:

- planting native grasslands and other vegetation

- planting native trees and shrubs in formerly forested wetlands and other habitats
- prescribed burning as a method of removing exotic species and to restore natural disturbance regimes necessary for some species survival
- removal of exotic plants and animals which compete with native fish and wildlife and alter their natural habitats

**B. General Information**

The Information Center for the Environment, at <http://ice.ucdavis.edu/> is a cooperative effort of environmental scientists at the University of California, Davis and collaborators at over thirty private, state, federal, and international organizations interested in environmental protection. Within this site, find the California Ecological Restoration Projects Inventory (CERPI) (direct link: <http://endeavor.des.ucdavis.edu/cerpi/>) and the California Noxious Weeds Projects Inventory (CNWCPI). (direct link: <http://endeavor.des.ucdavis.edu/weeds/>)

**CERPI** is a combined private/non-profit/government effort to establish a database, accessible through the Internet, containing information on restoration projects in California. This information will further the practice and science of restoration and assist agencies and practitioners during restoration planning and implementation. **CNWCPI** is a combined government/private/non-profit effort to establish a database, accessible through the Internet, containing information on noxious weed control in California. This information will further the practice and science of noxious weed control and assist agencies and practitioners doing noxious weed control throughout the state. CERPI and CNWCPI are both programs of the Natural Resource Projects Inventory (NRPI)

**The California Environmental Resources Evaluation System**

<http://www.ceres.ca.gov/index.html>

CERES is an information system developed by the California Resources Agency to facilitate access to a variety of electronic data describing California's rich and diverse environments. The goal of CERES is to improve environmental analysis and planning by integrating natural and cultural resource information from multiple contributors and by making it available and useful to a wide variety of users.

**California Wildlife Habitat Relationships**, at <http://www.dfg.ca.gov/wbdab/>

California Wildlife Habitat Relationships (CWHR) is a state-of-the-art information system for California's wildlife. CWHR contains life history, management, and habitat relationships information on 675 species of amphibians, reptiles, birds, and mammals known to occur in the state. CWHR products are available to purchase by anyone interested in understanding, conserving, and managing California's wildlife (Mayer and Laudenslayer 1988).

**A Manual of California Vegetation** (Sawyer and Keeler-Wolf) on line at

<http://endeavor.des.ucdavis.edu/cnps/>

**Forest Service Technical Reports** can be ordered from 970-498-1392.

### Other Sources of Assistance on Hardwood Rangelands

California Department of Fish and Game  
1416 Ninth St.  
Sacramento, CA 95814  
916-653-1738

California Department of Forestry and Fire Protection  
1416 Ninth St.  
Sacramento, CA 95814  
916-322-0623

California Cattleman's Association  
1221 H. St., Suite 101  
Sacramento, CA 95814  
916-444-0845  
email: staff@calcattlemen.org

The Nature Conservancy  
785 Market St.  
San Francisco, CA 94103  
415-777-0487

California Native Plant Society  
909 12th St., Suite 116  
Sacramento, CA 95825

California Farm Bureau Federation  
1601 Exposition Blvd.  
Sacramento, CA 95815  
916-561-5500  
email: cfbf@cfbf.com

### Appendix B. How to Monitor Bird Populations

---

Adaptive management requires the periodical gathering of information to ascertain whether management actions are achieving desired results. The most comprehensive and rigorous way of collecting this information is through a strategic program of monitoring using standardized methods that can be compared between years and between regions. Restoration and land stewardship programs need to build in long-term monitoring programs to assess the effectiveness of their activities. Without such data in the long term, such programs will ultimately have little on which to base claims of success or the need for continued funding.

#### Research and Monitoring

If habitat restoration or management is undertaken to benefit wildlife species, wildlife monitoring becomes the ultimate measure of success. There are many reasons that bird monitoring should be adopted as a basic component of long-term stewardship in preserves with significant habitats or significant bird populations:

- Birds are highly visible and cost effective to monitor.
- Birds can show relatively quick response in abundance and diversity to restored habitats (3 to 5 years).
- Birds can serve as indicators for key components of ecosystem health, such as acorn productivity, oak age structure, and understory vegetation composition.
- As secondary consumers (i.e., insectivores), birds are sensitive indicators of environmental change.
- By managing for a diversity of birds, most other elements of biodiversity are conserved.
- Bird monitoring can avoid future listing of declining species by identifying problems and solutions early.
- The only way to measure special-status bird species response to management and restoration is by monitoring bird populations.
- Because of the increasing popularity of birdwatching, there is great potential for public participation in bird monitoring.
- Birds are tremendously important culturally and economically and their popularity can help raise awareness of land-stewardship needs.

### Monitoring Strategically

Monitoring can be conducted at varying levels of intensity, depending on the objectives to be achieved and the resources available. The standardization of protocols is critical to comparing results across space and time. Many recent programs (Ralph et al. 1995, Martin et al. 1997, DeSante et al. 1999a) and publications (Ralph et al. 1993, Geupel and Warkentin 1995, DeSante et al. 1995, 1998, 1999b, Nur et al. 1999) have summarized methods, objectives, and how to use results.

Monitoring programs should always include an analysis plan and identification of issues or site-specific projects to be assessed. The primary purpose of site-specific monitoring is to assess the effects on wildlife of natural and anthropogenic stressors or disturbances in the environment. This knowledge is critical in determining the relative priority of identified conservation problems and in developing effective measures to address those problems. Monitoring is an integral component of the adaptive management feedback loop, allowing land managers, conservation groups, and land owners to assess the effectiveness of their habitat management and restoration programs.

Standardized monitoring across many sites at varying scales can be analyzed to highlight broad changes or trends in species presence, diversity, abundance and productivity. Ideally, a series of reference sites with long-term monitoring, using most if not all protocols below, will be developed for each California bioregion. Other sites will be monitored more opportunistically, depending on the objectives of the landowner.

The following is a list of common monitoring regimes from least to most intensive.

**1) Rapid assessment of habitat or designation of Important Bird Areas based on general vegetation characteristics and presence/absence of indicator species.**

**Method:** area search or point count as little as one census per site per year.

**2) Determine breeding status, habitat association, restoration evaluation and/or evaluation of changes in management practices.**

**Method:** area search or point count two or more times per year for 3 years. For restoration evaluation every other year, censusing should continue for at least 10 years.

**3) Determination of population health or source/sink status.**

**Method:** census combined with demographic monitoring for a minimum of 3 years (4 years preferable).

**4) Reference site.**

**Method:** point count census, constant effort mist netting and nest monitoring at a minimum of every other year for 10 years.

### Long-term Monitoring

Long-term monitoring provides a wealth of useful information about bird populations. In addition to parameters that can be determined by both short- and long-term monitoring (such as annual productivity, abundance, and diversity), patterns of variation in reproductive success and trends in abundance and diversity may also be described. Long-term monitoring is also the only method to monitor natural and human-induced changes in bird populations.

The Palomarin Field Station of the Point Reyes Bird Observatory provides an excellent example of the utility of a long-term monitoring program. Biologists have conducted mist-netting at the site for over twenty years. With the data collected, they have documented a population decline of Warbling Vireos and linked it to reproductive failure on the breeding grounds (Gardali et al. 2000).

### Standardized Methods Adopted by the Western Working Group and Monitoring Working Group of Partners in Flight

These are listed from least to most intensity of effort. All are described in detail in Handbook of Field Methods for Monitoring Landbirds (Ralph et al. 1993).

#### Area Search

The Area Search, adopted from the Australian Bird Count, is a habitat specific, time constraint census method to measure relative abundance and species composition. It may also provide breeding status. While still quantitative, this technique is ideal for volunteers as it mimics the method that a birder would use while searching for birds in a given area, allowing the observer to track down unfamiliar birds.

#### Point Count

The point count method is used to monitor population changes of breeding landbirds. With this method, it is possible to study the yearly changes of bird populations at fixed points and differences in species composition between habitats and assess breeding status and abundance patterns of species. The objective of point count vegetation assessment is to relate the changes in bird composition and abundance to differences in vegetation. These vegetation changes can either be over time or differences between habitats or study sites.

#### Mist Netting

Mist netting provides insight into the health and demographics of the population of birds being studied. Mist nets provide valuable information on productivity, survivorship, and recruitment. With these data, managers will have information on the possible causes of landbird declines or their remedies. This method is currently being used nationwide in the Monitoring Avian Productivity and Survivorship (MAPS) program (DeSante 1992).

#### Territory Mapping

Also known as "spot mapping," based on the territorial behavior of birds, where locations of birds are marked on a detailed map during several visits (a minimum of eight) in the breeding

season. By counting the number of territories in an area, this method estimates the density of birds. Distribution of territories, species richness, and diversity is also documented. This is an excellent method for assessing areas with limited habitat. Standard methods are described by Robbins (1970) and used by The Cornell Laboratory of Ornithology's resident bird counts.

#### Nest Monitoring

Also called nest searching, this technique measures nesting success in specific habitats and provides information on trends in recruitment; measurement of vegetation associated with nests may identify habitat influences on breeding productivity. Examination of nests also allows collection of life-history data (e.g., clutch size, number of broods, numbers of nesting attempts), which provide important insight into vulnerability of species to decimation or perturbations (Martin and Geupel 1993).



Western Scrub-Jay on nest

photo by Ian Tait

## When Oak Ordinances Fail: Unaddressed Issues of Oak Conservation<sup>1</sup>

Rudolph H. Light<sup>2</sup> and Linda E. Pedroni<sup>2</sup>

#### Abstract

The mandate by the California Board of Forestry in 1993 required each of the 41 counties which have significant oak woodlands to develop programs for the ultimate protection of this resource. As of 2001, a few counties have planned for the sustainability of their oak woodlands, but some counties may not be addressing the key components that will determine the overall future status of oak woodlands across counties and regions. Most counties and cities use the individual tree as the fundamental unit of conservation and neglect entirely the need for policies on oak woodland conservation and regeneration. They instead should regard the oak woodland as the functional unit and insist on large-scale regeneration. This paper presents some psychological reasons why the ingredients of some written plans are so inadequate that the plans have a high likelihood of failure. People tend to focus on their immediate environment while ignoring important background information and they base their planning judgments on small data sets, erroneously believing them to be representative of the larger environment. This often leads to poor policy decisions. Suggestions for reframing and broadening components of oak conservation are presented.

#### Introduction

Tree protection has been an important aspect for American communities for well over a century. As early as 1909, the city of Visalia undertook to preserve oak woodlands through public purchase, and by 1971, had enacted an ordinance prohibiting valley oak (*Quercus lobata*) removals without a permit (Strong and George 1990). During the 1980s the State Board of Forestry considered whether or not the State should mandate oak conservation and decided against it. In 1986 the University of California Integrated Hardwood Range Management Program (IHRMP) was created to provide research and education for the management of oak woodlands. Over the past 20 years, a lot of work has been done on technical and public policy aspects of oak woodlands (Bernhardt and Swiecki 2001, Plumb and Pillsbury 1987, Standiford 1991). In 1993 the State Board of Forestry directed the more than 40 counties which have oak woodlands to develop oak conservation plans. The suggested methods fell into three categories: ordinance, general plan process, or voluntary guidelines. Prior to the Board of Forestry directive, Bernhardt and Swiecki (1991) had compiled information on how to write ordinances for preserving trees. They recognized one of the problems was the public's tendency to save "specimen" or "heritage" trees and allow cutting of younger ones. Rossi (1990) pointed out that

<sup>1</sup> An abbreviated version of this paper was presented at the Fifth Symposium on Oak Woodlands: Oaks in California's Changing Landscape, October 22-25, 2001, San Diego, California.

<sup>2</sup> Conservationist and Clinical Psychologist, and Research Assistant, respectively, 11535 East Road, Redwood Valley, CA 95470.



ordinances sometimes resulted in loss of trees because landowners were cutting trees just under the protected diameter size. Writing and adopting plans has proven to be a great challenge.

Scientists have long known that regeneration is one of the most important factors in the health of the forests. Nearly a century ago Sudworth (1908) and Jepson (1910) noted several oak species were not reproducing well. Griffin (1971, 1973) wrote that both blue oak (*Quercus douglasii*) and valley oak replacement rates were low, as did Callaway and D'Antonio (1991) for coast live oak (*Q. agrifolia*). While adequate oak regeneration occurs in some areas, it is generally less so in the coastal ranges and foothill areas for most species (Steinhart 1978, White 1966). In southern California seedling death due to desiccation is common (Lathrop and Osborne 1990, Pancheco 1987). Muick and Bartolome (1987) surveyed the state and found that while blue oak seedlings were present, recruitment to adulthood was sporadic. Swiecki and others (1993) found wide geographic variability of blue oak sapling recruitment and stressed that many environmental variables are responsible for recruitment outcomes. According to Bolsinger (1988), the Oregon white oak (*Q. garryana*) reproduces only moderately well and in most of its range is only lightly stocked. He mentioned also that blue oak, valley oak, Engelmann oak (*Q. engelmannii*) and coast live oak were not regenerating well. It is necessary to point out that some oak species (especially those in the subgenus *Erythrobalanus*) are regenerating well over most of their ranges. Also, it appears that some species may naturally have infrequent pulses during which all the necessary environmental conditions are met to ensure seedling and sapling survival over time so as to become mature trees. Nonetheless, the trend for oak woodlands is decreasing acreage and lowered density, and impaired regeneration is an important factor.

Causes for poor regeneration have been investigated by many authors (Adams and others 1987; Borchert and others 1989; Gordon and others 1989; Griffin 1971, 1976; McCreary 1989, 1990; Standiford and others 1991; Welker and Menke 1990). Botkin and others (1991) discussed transitional and long term impacts on forests due to global warming. Brown and Davis (1991) discussed the loss of valley oaks in Santa Barbara County due to natural causes over a 60-year period, stressing the fact that there was no replacement into the canopy. They concluded by saying, "...it appears that an active program of sapling propagation is necessary to maintain or increase the size of the valley oak populations in the region."

In the last decade there has been an extraordinary political effort to conserve oaks. Some counties acted quickly in response to the Board directive, and Standiford and Bartolome (1997) commented favorably on Tehama County. By now, most counties have at least written a needs assessment, and many, such as Santa Barbara, El Dorado and Sonoma Counties, are with assistance from the IHRMP well underway with extensive and careful conservation planning. However, in most counties tangible results by and large have not been achieved.

One can enumerate the reasons for the oak woodland losses: residential development, agriculture, woodcutting, wildfire, rangeland improvement and most recently sudden oak death. In this paper, we would like to reframe the issue of oak ordinances and regulations and their lack of success in several ways which will be unfamiliar to many. One of us is a psychologist and naturalist, and we address the issues as friendly critics seeking explanations as to why the process for effective oak woodland protection is taking so long. Our thesis is that planners and citizen groups tend to focus on the wrong things when it comes to oak woodland conservation.

### Conversions from Oak Woodlands

The most crucial issues as far as policies are concerned are how counties regulate the conversion of oak woodlands to other uses, and how counties mitigate when losses of oak woodlands occur (table 1). These conversions include six categories, and each will be discussed in the context of existing regulations.

Table 1—Selected counties: highlights of mitigation policies.<sup>1</sup>

Alameda-1994 general plan	General policy of requiring tree replacement
Calaveras-1996 guidelines	suggests tree replacement when removed for construction
Contra Costa-1994 ordinance	pay fees for tree removal; replace when protected tree damaged
Fresno-1997 draft guidelines	suggests tree replacement when removed for construction
Glenn-1994 guidelines	suggests landowner plan should address seedling regeneration
Lake-1995 guidelines	site specific through vineyard regulations, grading ordinance
Los Angeles-1993 ordinance	may require tree relocation or replacement with 2 for 1 with 2 years care; if not feasible pay fees into oak forest fund
Madera (Eastern)-1999 guidelines	suggests to reforest through natural or artificial regeneration
Marin-1999 ordinance	regeneration and replanting encouraged, can be required to replace trees; if not feasible pay fees into tree replacement fund
Mariposa-1995 guidelines	suggests to reforest through natural or artificial regeneration
Monterey-1997 ordinance	may require relocation or replacement at 1:1 ratio; or other requirements as needed to mitigate environmental impacts
Napa-1999 ordinance	required to replace tree on ridge line or hilltop if visible from public roadway
Nevada-2000 ordinance	removal requires inch for inch replacement with long-term maintenance; if not feasible pay fees into tree preservation fund
Placer-1996 ordinance	may require replacement in kind inch for inch, propagation, revegetation; if not feasible pay fees into tree preservation fund
Riverside-1997 ordinance	mitigation required only in case of unlawful removal; same species replanted in same spot within 6 months
San Luis Obispo-coastal zone 1995 ordinance	requires replacement when removed for development or safety
Santa Barbara-2001 proposed ordinance	requires replacement and maintenance; if not feasible pay fees into oak tree conservation fund; management plans may also be required
Santa Clara-1997 ordinance	mitigation required only in case of unlawful removal; may require replacement at 10:1 ratio
Shasta-1995 guidelines	suggests protecting seedlings on rangeland and replacing trees when removed for construction
Sonoma-1989 and 1997 ordinances	for valley oak, must plant seedlings, retain other valley oak, or pay in lieu fees; for other protected oaks, may require replacement or fees as determined by value charts
Tehama-1994 guidelines	suggests replacing trees when removed for construction
Tuolumne-1995 guidelines	suggests replacing trees when removed for construction
Yuba-1996 general plan	general policy to avoid oak tree removal and to encourage protection and regeneration; removal of valley oaks should include replacement program with maintenance and monitoring

<sup>1</sup>Counties without mitigation policies: Amador, Butte, Colusa, Kern, Mendocino, Merced, Stanislaus, Tulare.

### Specimen Tree Trap

Counties and cities typically spend large amounts of money and time to save the heritage or landmark trees and at the same time ignore the losses in the forest. We call this the “specimen tree trap.” Consider a typical ordinance, say from Santa Clara County. Trees are protected if they have a diameter of at least 12 inches at 4.5 feet above the ground, but only in certain areas of the county. In the agricultural areas, limited firewood cutting is allowed, and the larger the parcel the more cutting that can be done, so that up to 10 percent of the trees of 12 inches or greater diameter may be cut in any one year (Santa Clara County 1995, 1997). Mitigation to control erosion is required in the context of harvesting but not to mitigate the loss of oak woodland habitat. Legally, one could on larger parcels remove all protected trees in just over a decade. There is no provision for replanting trees after harvest. Nonetheless, one best not remove a specimen tree. If a heritage tree in Santa Clara County is cut, the potential fine is \$200,000. In Contra Costa County, removal is limited if the diameter is 6.5 inches or greater (Contra Costa County 1994). However, the idea of saving oak woodlands is barely mentioned and not enforced. There is nothing in either of these ordinances or in the one from Marin County or in many others, about saving woodlands, but there is a great deal about saving the large and mature trees. Since some counties primarily use diameter for determining which trees to protect, as a result saplings are not protected (*table 2*). In contrast to other counties, Marin County at least recognizes and states that it will not address the issue of lack of regeneration (Marin County 1996, 1999).

**Table 2**—Selected counties: tree removal size which may require a permit.<sup>1,2</sup>

Alameda-1997 general plan	20 in circumference native, 30 in circumference introduced
Contra Costa-1994 ordinance	6.5 in dbh (or groves of 4 or more trees)
Los Angeles-1993 ordinance	8 in dbh
Marin-1999 ordinance	6 in dbh (this dbh specific to oaks)
Monterey-1997 ordinance	6 in diameter 2 ft agl
Nevada-2000 ordinance	36 in dbh (specific to oaks) or hardwood grove with ≥33 pct canopy; Nevada City Area 10 in dbh
Placer-1996 ordinance	6 in dbh when >50 pct of trees removed
Riverside-1997 ordinance	6 in dbh and 15 ft high if on parcel >0.5 acre and above 5,000 ft
San Luis Obispo-coastal zone 1995 ordinance	8 in dbh
Santa Barbara-2001 proposed ordinance	4 in dbh for deciduous oaks; 8 in dbh for live oaks
Santa Clara-1997 ordinance	12 in dbh
Sonoma-1989 and 1997 ordinances	9 in dbh; valley oak has own regulations
Yuba-1996 general plan	6 in dbh specific to valley oaks

<sup>1</sup>Counties without diameter stipulation: Amador, Butte, Calaveras, Colusa, Fresno, Glenn, Kern, Lake, Madera (Eastern), Mariposa, Mendocino, Merced, Napa, Shasta, Stanislaus, Tehama, Tulare, Tuolumne.  
<sup>2</sup>There are many exceptions; agricultural and rangelands are often exempt or have less stringent regulations.

The most striking example of the specimen tree trap in northern California is the Danville Oak, located in a median strip of a four-lane road. Its roots are covered with pavement. This is a valley oak, perhaps 300 years old, moderately diseased and senescent. According to the arborist, it will live for perhaps another 50 years with careful management (Peña 2000a, 2000b). The town council voted to spend \$150,000 (later reduced to \$70,000) to put a steel structure around this oak to protect cars and people from tree breakage. However, if one looks carefully at the outskirts of town, one realizes that the real problem for Danville’s oaks rests with the development pressure in the hills to the west, where thousands of houses already exist. There is some protection through park dedication in the hills, but the citizens and planners focused their time and a lot of money on the tree and not the forest. This can never result in oak woodland preservation.

### Vineyard Conversion

Vineyards are perceived by many as a major cause of oak woodland decline. However, in most places, the new vineyard impact is exaggerated. It is only one important factor in the loss of oak woodlands, and sometimes seems more important than other causes because of the high visibility of some new vineyards. As we begin this topic it is time to discuss some findings from cognitive psychology. Since this paper focuses on public policy of oaks more than psychology, we will keep psychology theory brief, merely making the connection between the two subjects. Please bear in mind that there is a body of experimental evidence regarding human behavior under consideration here, and it has been applied to political processes. Humans typically overestimate the frequency of rare events, say airline crashes and underestimate the frequency of common events, such as herpes (Lichtenstein and others 1978, Light 1983, Slovic and others 1976). The same two psychological misperceptions occur for forest land. We also tend to rely on small numbers to make our decisions (Tversky and Kahneman 1971). We focus on the immediate and visually important things which we believe impact us directly. Merely stating that humans tend to focus on the immediate is of course trivial. What is more cogent is that experimentally, humans have been found to consciously disregard and dismiss that which is not immediate even though people may be well aware there is more information than that which they use. Thus, if a phenomenon is out of sight or simply out of our neighborhood, even if we are cognizant of it we discount its importance. Hence, a rational decision about the Danville Oak was not made and the real problems for oak woodlands were ignored. In our discussions with planning staff, we found that some of the planners knew that their plans only focused on preservation of individual trees, but other planners believed that was all that was necessary. We can state that in talking to planning staff personnel of many counties, no small number are frustrated with the slow pace of oak conservation no matter how defined or delimited.

Many people would be surprised to learn how much oak woodland exists in California. Surveys using different methods and at different times yielded similar and credible results. Bolsinger (1988) estimated that there were 9.6 million acres of hardwood rangeland in California and that 72 percent of the hardwood types were in private hands. The most recent survey is that of Greenwood and others (1993), revised by Biles and Love (1998). According to them, there are 10.5 million acres of hardwood rangelands in 45 counties with about 70 percent in private ownership. Nearly three-quarters of a million acres are reserved in both private and public

sectors. Many citizens would underestimate the total oak woodland acreage and overestimate the number of trees at risk.

With what we have just said in mind, three counties may be used as examples to discuss the conversion of oak woodlands to vineyards: Santa Barbara, San Luis Obispo, and Lake. The Santa Barbara story is now famous as a case study of how to develop plans for tree and oak woodland preservation but it has been a long and often ugly process. It was triggered by a perceived threat, a minor threat, the loss of fewer than 900 oaks on a single project of 500 acres of grazing land converted to grape vines. Had those oaks not been visible to passersby and had they not been *perceived* to be the last of a breed, less attention would have been given to them and the Santa Barbara story would have evolved differently, hopefully to the same end but in a much less divisive manner. In 1995 in Santa Barbara County, there were 8,976 acres of grapes, and in 2000 15,869 acres (California Agricultural Statistics Service 2001). Much of the new planting is on land that was previously devoted to grazing and did not involve clearing oak trees (Leider, personal communication). In response to this one project and fearful of more conversions to vineyards, a long public process was initiated to write an ordinance based on an environmental impact report (EIR), such report and proposed ordinance only covering lands in the private sector. The Santa Barbara County Oak Tree Protection Program EIR reports only the oak woodlands of 198,000 acres on private property in the project area, and omits entirely the oak woodlands on public lands (Santa Barbara County 2001). Looking at the big picture, Santa Barbara County has about three times the amount of oak woodland cited in the EIR, a total of 634,600 acres of hardwood rangelands (Biles and Love 1998), hardly on the verge of extinction. There are 356,000 acres under public ownership, and 278,600 acres in private hands. So this project which resulted in the removal of the oaks on the 500 acres accounted for about 0.2 percent of the privately held oak woodland, and 0.09 percent of the total oak woodland in the county. We know many of these trees on the subject property were valley oaks but their loss was still minor compared to the total. The attention paid to the few oaks which were removed is greater than rationally justified based on total hardwood rangeland acreage. It needs to be said that Santa Barbara County currently is undertaking extraordinarily comprehensive planning for oak woodlands, and it goes well beyond vineyards.

San Luis Obispo County is a little different. They have workable tree and habitat protection in place, but only in the coastal zone. As of 2000, there are 20,425 acres of vineyards, up from 10,055 acres in 1995 (California Agricultural Statistics Service 2001). New vineyards are going in with some oak displacement but most of the vineyards are being developed on pre-existing agricultural land (Trinidad, personal communication). The concern with conversion to vineyards is to some extent based on the concept of perceived acceleration of conversions as well as the total acreage. Data and projections are as yet inadequate to determine final vineyard development.

The types of woodlands in this county are highly disparate. Coast live oak and blue oak habitat are well represented (242,100 and 271,300 acres, respectively), while valley oak habitat consists of only 2,700 acres. However, it is the coastal area, home to the plentiful coast live oak west of the Santa Lucia Mountains which is regulated for tree cutting. The uncommon valley oak, located inland, is without protection and without replanting requirements when one is cut. Just knowing these figures allows us to infer that if people wanted to further protect oaks in San Luis Obispo County, the county should regulate valley oak habitat, where virtually no protection presently exists. Planners there are aware of the inconsistency.

Lake County lost an estimated 500 to 800 acres of oak woodland in the period 1997 to 1999, mostly to vineyard and some to housing (Lake County 2001). There is a strong movement to control cutting trees in some areas, but no replanting requirements despite the County Resolution on oak woodlands management (Lake County 1995). Looking at the background information which does not appear in the County planning document, Lake County has 6,828 acres of vineyard, up from 2,966 in 1995 (California Agricultural Statistics Service 2001). At the same time, it has 237,900 acres of hardwood rangelands, mostly interior live oak (*Q. wislizenii*) and California black oak (*Q. kelloggii*), with significant areas of blue oak as well, but few valley oak remain. This county focuses efforts on specimen trees or the relatively few trees in and around vineyards and subdivisions. It is a classic case of ignoring the background information in favor of the individuating information and using solely the latter on which to base the conservation planning decisions.

Having used these examples where the underlying information was ignored, where the acreage of oak woodlands is markedly underestimated and decisions were made on the basis of a very small amount of land and land use change, we want to introduce a related concept. It is called the base-rate fallacy (Bar-Hillel 1980). This refers to the process of making judgments and predictions based on specific and usually inadequate information instead of taking into account the total information available. In other words, we neglect all the background or collateral information which isn't in clear view and focus on the specific and local information even though that background information is often far more salient than the local information. In the three counties discussed, dire predictions are made on the basis of a limited sample, while the hundreds of thousands of acres of viable woodlands are neither recognized nor factored into the planning. It is critical to study the base-rates prior to drawing up the regulations.

The psychological reasons for this behavior have been studied. One finding suggests that we don't pay attention to the background information because it is abstract and remote, while we feel that the specific information is concrete and salient. The background base-rate information is ignored because people, in spite of the added collateral information, believe that the base-rate *ought* to be ignored (Bar-Hillel 1980). People believe the background information has no relevance to them, nor to the decision process for the problem at hand. Having said that, we will turn to a conversion which is as yet not well studied over the long term, one which will likely be found ecologically more important than vineyards, but to which little public attention is paid and which illustrates the point.

### **Conversion from Wildfire**

Although conversions to agriculture and development are widely reported, aftermath of wildfire is not. There is no large body of literature specific to seral succession of oak woodlands following high intensity wildfires, but general information may be located in Biswell (1989) and Wright and Bailey (1982). Mensing (1992) noted blue oak regeneration in southern California over the last 150 years is associated with fire. Holmes (1990) and McClaran and Bartolome (1989) believe periodic low intensity fires contribute positively to enhanced oak regeneration. Allen-Diaz and Bartolome (1992) found that a prescribed low intensity underbrush and grass burn after fall rains had commenced did not much alter blue oak seedling survival compared to a no burn plot. However, an out of control high

intensity summertime fire with a heavy fuel load is a different matter. We believe these large-scale wildfires in oak woodlands have significant and damaging long term as well as short-term effects to the oak forests for those species which are not naturally reproducing well. We certainly acknowledge that ecological processes span more than human lifetimes, that fire is an integral part of the California oak woodlands landscape and that fire acts simultaneously with other factors to determine forest composition outcomes. But we also maintain that the relatively common occurrences of fire leads us all to disregard the significance.

We mentioned that people tend to underestimate the frequency of common events and with that, the significance of them. Fires are frequent in California. There were fires on the Light Ranch in Mendocino County in 1992 and 1995. These fires resulted in the loss of over 800 mature oak trees, some over 300 years old, including valley oak, blue oak, Oregon white oak, California black oak, interior live oak, oracle oak (*Q. x moreha*) and canyon live oak (*Q. chrysolepis*). We've replanted the area with nearly 1,000 acorns from local trees but without our planting efforts it is doubtful the forest would ever return, at least not for centuries. These trees are gone as surely as if removed by a bulldozer.

Every year tens of thousands of acres burn in California, and much of this is oak woodland. In 1999, on land under California Department of Forestry and Fire Protection (CDF) jurisdiction, more than 285,000 acres burned, and in 2000, over 72,000 acres burned (CDF 2001). The largest single conversion in Mendocino County from oak woodland to other habitat was by one fire in the summer of 1987, burning 42,500 acres in Mendocino County and 10,500 acres in Lake County (Schott, personal communication), much of it blue oak woodland. This specific fire started in July and became a high intensity fire which consumed whole forests. In many acres of the burn, conversion to another habitat type occurred. The fire destruction was enormous, but being humans we don't assess its significance as skillfully as we do a conversion of 300 highly visible acres to a vineyard. All the oak woodland conversions to vineyards in the last decade over the entire state hardly approach one-half the acreage or the number of trees destroyed by this one major fire. When we factor in the number of wildfires we have in oak woodlands over a year or a decade, we can conclude that fire is more destructive to oaks than conversion to vineyards. And destruction of oak woodlands by wildfire is virtually ignored unless the land is close to urban areas. Succession will in time perhaps develop an oak woodland, but given both the limited success of natural regeneration of blue oak and the several centuries required, this conversion is important and long lasting. We know of no large-scale oak reforestation program following a wildfire. The remedy to reduce this type of conversion threat is to prevent the hot fires through proper grazing management and prescribed burning, and if wildfires occur, to give the landowners technical and financial incentives to replant and reforest. Perhaps the role of wildfire in the loss of oak woodlands needs to be addressed and policies developed. Once policies are in place, the above-mentioned management practices can become part of ordinances or general plans.

### **Wood Cutting**

In sparsely populated rural counties, woodcutting is a major cause of the loss of oaks, primarily blue oak. About 6,000 acres per year are harvested. Data from about a decade ago indicated that in Shasta County, net addition to tree volume was significantly less than the amount harvested for firewood while in Tehama County volume was marginally increasing (Standiford and others 1996). Both counties adopted recommendations for canopy retention but the authors point out that only 10 percent of the Tehama County plots and 25 percent of the Shasta County plots actually had at least 30 percent canopy retention. Rural counties by and large have voluntary guidelines for oak woodland management rather than ordinances. This has led to a curious phenomenon, illustrated by Glenn County. Its 1994 resolution to adopt guidelines refers to the "importance of private property rights" and economic viability four times but the guidelines never refer to the need to leave stumps to sprout or to plant new trees (Glenn County 1994a, 1994b). Calaveras, Tehama, Tuolumne, Madera, Mariposa and Shasta Counties have all adopted similar guidelines. In their own way, these counties just as with the city of Danville, attempt to save the older trees and allow the younger ones to be removed, only "suggesting" to keep some of all species and sizes, but there is no requirement in any of these counties to do anything to ensure this outcome. Voluntary guidelines can only suggest, so incentives are needed. The guidelines of these counties as written are a recipe for the permanent loss of the oak woodlands. The remedies for California are simple. Harvest for sustainability (Standiford and others 1990). Encourage or require replacement seedlings and saplings by planting, or mechanical protection of naturally sprouted seedlings. Conduct woodcutting in the same manner as we do fishing. Require a minimum size instead of a maximum, and replacement along with conservation. We utilize the federal Environmental Quality Incentives Program for soil conservation and state Senate Bill 271 funds for riparian restoration. We now need to develop similar cost share programs for oak woodland restoration, perhaps along the lines of the proposed Assembly Bill 242.

### **Residential and Other Development**

In many areas of the state and the urban fringes of all larger cities such as the ones in the Los Angeles Basin where the Engelmann oak is making its last stand, residential development is the pressing problem. In fact, according to Giusti and Tinnin (1993) the single largest threat to the state's oak woodlands is residential development. Each year 30,000 acres of hardwood rangeland are lost to residential and commercial uses (Standiford and others 1996), and there is little required in the way of mitigation. The more urban counties tend to favor ordinances, and often punitive ones at that. In so doing, they do not really encourage conservation or regeneration, but merely regulate tree cutting as they attempt to save specimen trees. In a few counties, a specified number of seedlings or acorns must be planted when trees are cut. Sonoma County generally requires between a 16:1 to 32:1 replacement ratio and protection to sapling size; Santa Barbara County proposes up to 15 seedlings or 45 acorns for each tree cut, but these regulations are rare among counties. Usually, replanting is required only as mitigation for other procedures on a case by case basis, and thus fails the woodlands. The result is a permanent loss or at best, serious fragmentation.

### **Sudden Oak Death**

As it stands today, no county has the power to remove, treat or spray an oak or other tree or shrub infected with *Phytophthora ramorum* without the landowner's permission. The lack of county authority to deal with this threat is a glaring omission and hopefully will be rectified even as research is still being conducted. In speaking with several planners in the Bay Area, the very region where sudden oak death exists, most were not aware of the 10 host species which this fungus infects nor of the ecological significance of the disease. Fortunately, the State has recently exerted some authority in the matter (Fimrite 2001). Unfortunately, sudden oak death with rampant and uncontrollable spread may cause permanent and large-scale conversion of much of our oak woodlands.

### **Suggestions and Summary**

The problem discussed here is that those of us who care for oaks and forests have a marked tendency to dwell on the specific trees and ignore the forest. We have a belief in the truth of small numbers (Tversky and Kahneman 1971) and we not only disregard the background information, we actually believe it is unimportant. Despite claims, many in the planning business do not look at all the information. Tehama County focuses on private property rights, Visalia on the preservation of specimen trees, and Lake County on vineyards. Unfortunately, this often leads to poor decisions. We are strongly conditioned by our local circumstances and we have a difficult time extending ourselves to see the big picture (Tversky and Kahneman 1974). In being too dependent on direct information, Slovic and others (1976) point out, "...cognitive limitations force decision makers to construct simplified models in order to deal with the world." They further state, "The experimental results indicate that people systematically violate the principles of rational decision making when judging probabilities, making predictions, or otherwise attempting to cope with probabilistic tasks." We need to consider many variables simultaneously, and man has a tough time doing this, for we rely only on the immediate information and ignore the important background data.

Typically, persons in authority decide matters intuitively, what looks good in the short term, what is specific to the immediately perceived problem; in turn they embrace procedures that are easy to explain, rationalize and defend. This strategy won't work to conserve and expand oak woodlands.

However, there are solutions to our cognitive dilemma. First, we must recognize that we are prone to these cognitive errors and then adopt a new viewpoint. We need to be aware that we are dealing with a multivariate problem, which encompasses far more than trees and conversions, and which includes the whole scope of geography and in particular natural disturbance regimes, ecological succession, and expectations on the landscape over time. The planners and interested groups must shift to a multivariate approach and learn probabilistic reasoning. Following are some suggestions.

### **Plant Seedlings**

While there is some controversy regarding the long term efficacy (or even the need) for artificial regeneration, many papers have been written on methods to enhance seedling survival and sapling recruitment (Costello and others 1991,

Costello and others 1996, Griggs and Peterson 1997, Light and Buckner 1999, McClaren 1987, McCreary 2001, Plumb and De Lasaux 1997, Roberts and Smith 1982, Schettler and Smith 1980). Our personal observations and experiments lead us to believe that some intervention (at least in the North Coast Ranges) is essential. Complete artificial regeneration by planting acorns, watering and protecting the seedlings is very successful but costly, and we have found that merely caging seedlings works reasonably well for interior live oak and black oak. However, for some species we see no alternative to a complete artificial program. We believe that artificial regeneration (or at least caging natural seedlings) should become a major part in oak woodland conservation public policy to mitigate natural and human caused woodland losses. When vineyards are established, it is an easy matter to plant, irrigate and protect seedlings from herbivores. Some counties already require replanting but due to the difficulty in propagating oaks to sapling stages, we would encourage counties to require a 50:1 ratio of replacement. This would encompass any and all conversions, whether deliberate such as woodcutting, housing developments and agriculture, or if accidental such as fire or sudden oak death. Don't prohibit cutting, but grow new forests with the help of partial funding from the public sector. Encourage and help pay for planting even when no conversion has occurred. Allow offsite mitigation. Whatever else is done, plant trees on private and public lands alike.

### **Estimate Probability of Conversion**

The current stars in the planning world are in the counties of El Dorado (Greenwood and Saving 1999), Sonoma (Brooks and others 1999) and Santa Barbara (Santa Barbara County Planning and Development Department 2001). The first two are using GIS methods to map and determine the probable places of conversions. This method needs to be expanded and quantified so that one assigns a probability estimate to the type of conversion. In the hills of Mendocino County the likelihood of adding homes is greater than the likelihood of new vineyards, and both are far less likely than fire. In the western hills of Colusa County, the pressure appears to be from woodcutting and grazing improvement, and the likelihood of residential development or vineyards is practically zero. To estimate conversion from oak woodland to some other habitat one needs to use both direct and collateral information. Every acre needs to be assigned a probability of conversion based on all the past information of nearby lands as well as on current uses. This is a complicated multivariate problem, and to estimate these probabilities requires extensive geographic information and maps at least including zoning regulations and legal land use possibilities, census data, current land use, adjacent land use, slope, soil type, climate, proximity to urban centers and transportation. In addition, knowledge of the forest or rangeland itself including species present, age structure, fuel load, and canopy information is needed. Differential protection by species will lead to better management although most counties don't address this issue (*table 3*). The experts also need to be able to predict where oak woodlands can flourish in places where restoration is needed.

What we suggest is that planners need to adopt a probability mode of thinking and correctly assess risk of conversion in each area of every county while at the same time recognizing that it is a dynamic and ongoing challenge. Planners and politicians, bureaucrats and regulators need to learn how to properly identify and evaluate the risks, and proactively conserve the resources. We must keep in mind that potential outcomes are not equally probable, for a steep hillside is more likely to burn than to

become a vineyard, and to date the risk for sudden oak death in the San Francisco Bay area is far greater than in the Sierra foothills.

**Table 3**—Selected counties: differential protection of oaks by species.

Calaveras-1996 guidelines	suggests retaining some oaks of all sizes and species
Contra Costa-1994 ordinance	all oak species treated alike
Fresno-1997 draft guidelines	suggests retaining some oaks of all sizes and species
Lake-1995 guidelines	valley oak specifically mentioned in Upper Lake-Nice Area Plan
Los Angeles-1993 ordinance	all oak species treated alike
Madera (Eastern)-1999 guidelines	suggests retaining some oaks of all sizes and species
Marin-1999 ordinance	all oak species treated alike
Mariposa-1995 guidelines	suggests retaining some oaks of all sizes and species
Monterey-1997 ordinance	all oak species treated alike
Nevada-2000 ordinance	emphasis on protecting blue oak and valley oak
Santa Barbara-2001 proposed ordinance	differentiates deciduous oaks from live oaks
Santa Clara-1997 ordinance	California black oak receives special treatment when found growing with commercial species
Shasta-1995 guidelines	suggests retaining some oaks of all sizes and species
Sonoma-1989 and 1997 ordinances	valley oak has own regulations; all other oak species treated alike
Tehama-1994 guidelines	suggests retaining some oaks of all sizes and species
Tuolumne-1995 guidelines	suggests retaining some oaks of all sizes and species
Yuba-1996 general plan	differentiates valley oak from foothill oak woodlands

### Reserve Oaks on Public Lands

Biles and Love (1998) have calculated for each species the number of protected acres (private and public) it would take in each county to reach the statewide average of protected acres. For most counties, the greatest impact for the conservation of the oak woodlands could come by merely reserving oaks on the public lands. Think of the positive impact in Santa Barbara County if the planners could work with other agencies to reserve forever the 356,000 acres in the Los Padres National Forest and other federal holdings. Instead, they focused on the smaller total acreage in the private sector. Planning departments are either loath to be involved with or not knowledgeable about public lands. Many ordinances, e.g. Santa Barbara and Riverside, specifically exempt federal, state and local public lands from the regulations, although the natural resources know no boundary. Other ordinances ignore public lands altogether. Very few counties, e.g. Santa Clara, apply their regulations to public property.

Planners will say they have no jurisdiction over federal and state lands. When asked if they think these lands ought to be in the reserves, they will reiterate their position and then say they feel the private sector needs regulating. It may be naive but this sounds like a turf issue. But most planners simply do not know how much

federal and state land exists in their own counties. One planner we spoke with thought her county had at most a couple of thousand acres of hardwood rangeland when in fact it is twenty times as much. Even if they are aware of public holdings, these holdings are excluded from county hardwood acreage totals leading to an underestimation and misrepresentation of the extent of total oak woodlands. Once more, we see the belief in small numbers and the underestimation of common events. By reserving oaks on public lands and planting seedlings, it would show a societal commitment to the importance of oak woodlands.

### Use Existing Knowledge

In the preparation of this paper, we were struck by how many different rules there are, and with few exceptions how seemingly little communication there is among counties. There is a vast amount of information available, from state and university surveys of species by county, to ordinances and general plans available for the asking, to existing GIS studies on a variety of topics. Generally speaking, the planning documents are singular and do not benefit from the current and useful literature. While uniform regulations throughout the state may not be beneficial, at least a working familiarity with the regulations and guidelines from other counties is a necessity for everyone involved in the management of oak woodlands.

### Acknowledgments

We wish to thank the more than two dozen planners from as many county planning departments who talked to us at length and who provided us with ordinances, general plans, voluntary guidelines and other written material. Tom Schott, District Conservationist with the Natural Resources Conservation Service in Mendocino County, kindly read and criticized the manuscript, and supplied historical aerial photographs.

### References

- Adams, T.E., Jr.; Sands, P.B.; Weitkamp, W.H.; McDougald, N.K.; Bartolome, J. 1987. **Enemies of white oak regeneration in California.** In: Plumb, T.R; Pillsbury, N.H., technical coordinators. Proceedings of the symposium on multiple-use management of California's hardwood resources; 1986 November 12-14; San Luis Obispo, CA. Gen. Tech. Rep. PSW-100. Berkeley, CA: Pacific Southwest Forest and Range Experiment Station, Forest Service, U.S. Department of Agriculture; 459-462.
- Alameda County. 1994. **Alameda County general plan: east county area plan.** Vol. 1: Goals, Policies and Programs.
- Alameda County. 1997. **Alameda County general plan: Fairview area specific plan.**
- Allen-Diaz, B.H.; Bartolome, J.W. 1992. **Survival of *Quercus douglasii* (Fagaceae) seedlings under the influence of fire and grazing.** *Madroño* 39(1): 47-53.
- Bar-Hillel, M. 1980. **The base-rate fallacy in probability judgments.** *Acta Psychologica* 44: 211-233.
- Bernhardt, E.A.; Swiecki, T.J. 1991. **Guidelines for developing and evaluating tree ordinances.** Unpublished report to the California Department of Forestry and Fire Protection Urban Forestry Program; 76 p.

- Bernhardt, E.A.; Swiecki, T.J. 2001. **Restoring oak woodlands in California: theory and practice**. Vacaville, CA: Phytosphere Research; 16 p.
- Biles, F.E.; Love, T. 1998. **An update to the extent, ownership, and reserved status of California's hardwood rangelands**. Unpublished report to the California Department of Forestry and Fire Protection Fire and Resource Assessment Program; 89 p.
- Biswell, H.H. 1989. **Prescribed burning in California wildlands vegetation management**. Berkeley: University of California Press; 255 p.
- Bolsinger, C.L. 1988. **The hardwoods of California's timberlands, woodlands, and savannas**. Resource Bull. PNW-RB-148. Portland, OR: Pacific Northwest Research Station, Forest Service, U.S. Department of Agriculture; 148 p.
- Borchert, M.I.; Davis, F.W.; Michaelsen, J.; Oyler, L.D. 1989. **Interactions of factors affecting seedling recruitment of blue oak (*Quercus douglasii*) in California**. Ecology 70(2): 389-404.
- Botkin, D.B.; Nisbet, R.A.; Bicknell, S.; Woodhouse, C.; Bentley, B.; Ferren, W. 1991. **Global climate change and California's natural ecosystems**. In: Knox, J.B.; Scheuring, A.F., eds. Global climate change and California. Berkeley: University of California Press; 123-149.
- Brooks, C.N.; Heaton, E.; Newburn, D.; Merenlender, A.M. 1999. **Modeling vineyard expansion in California's north coast: developing statistical models and evaluating consequences for the surrounding oak woodland landscape**. ESRI International User Conference; July 26-30, 1999; 21 p.
- Brown, R.W.; Davis, F.W. 1991. **Historical mortality of valley oak (*Quercus lobata*, Née) in the Santa Ynez Valley, Santa Barbara County, 1938-1989**. In: Standiford, R.B., technical coordinator. Proceedings of the symposium on oak woodlands and hardwood rangeland management; 1990 October 31- November 2; Davis, CA. Gen. Tech. Rep. PSW-126. Berkeley, CA: Pacific Southwest Research Station, Forest Service, U.S. Department of Agriculture; 202-207.
- Calaveras County. 1996. **A resolution adopting oak woodland voluntary management guidelines and establishing a hardwood advisory committee for Calaveras County**. Board of Supervisors Resolution No. 96-284.
- California Agricultural Statistics Service. 2001. **California grape acreage 2000**. Sacramento, CA: California Department of Food and Agriculture; 55 p.
- California Department of Forestry and Fire Protection. 2001. **CDF Fire Season Summary**. 29 March 2001; Web address: <http://www.fire.ca.gov>.
- Callaway, R.M.; D'Antonio, C.M. 1991. **Shrub facilitation of coast live oak establishment in central California**. Madroño 38(3): 158-169.
- Contra Costa County. 1994. **Tree protection and preservation ordinance of Contra Costa County**. Ordinances 94-59, 94-22, Chapter 816-6.
- Costello, L.R.; Peters, A.; Giusti, G.A. 1996. **An evaluation of treeshelter effects on plant survival and growth in a Mediterranean climate**. Journal of Arboriculture 22(1): 1-9.
- Costello, L.R.; Schmidt, R.H.; Giusti, G.A. 1991. **Evaluating tree protection devices: effects on growth and survival—first year results**. In: Standiford, R.B., technical coordinator. Proceedings of the symposium on oak woodlands and hardwood rangeland management; 1990 October 31- November 2; Davis, CA. Gen. Tech. Rep. PSW-126. Berkeley, CA: Pacific Southwest Research Station, Forest Service, U.S. Department of Agriculture; 31-35.
- Fimrite, P. 2001. **Quarantine to halt spread of oak disease**. San Francisco Chronicle 19 May 2001. A13.

- Fresno County. 1997. **Fresno County resolution final draft and oak woodland management guidelines**. Oak Guidelines Steering Committee for Fresno County; 3 p.
- Giusti, G.A.; Tinnin, P.J., eds. 1993. **A planner's guide for oak woodlands**. Berkeley, CA: Integrated Hardwood Range Management Program, Department of Forestry and Resource Management, U.C. Berkeley; 104 p.
- Glenn County. 1994a. **Resolution establishing landowner oak management guidelines**. Board of Supervisors Resolution No. 94-094. 3 p.
- Glenn County. 1994b. **Voluntary guidelines for oak rangeland management in Glenn County**. 3 p.
- Gordon, D.R.; Welker, J.M.; Menke, J.W.; Rice K.J. 1989. **Competition for soil water between annual plants and blue oak (*Quercus douglasii*) seedlings**. Oecologia 79: 533-541.
- Greenwood, G.B.; Marose, R.K.; Stenback, J.M. 1993. **Extent and ownership of California's hardwood rangelands**. Sacramento, CA: California Department of Forestry and Fire Protection, Strategic and Resources Planning Program; 34 p. plus appendices.
- Greenwood, G.; Saving, S. 1999. **Current and future patterns of development in El Dorado County**. Sacramento, CA: California Department of Forestry and Fire Protection, Fire and Resource Assessment Program; 27 p.
- Griffin, J.R. 1971. **Oak regeneration in the upper Carmel Valley, California**. Ecology 52(5): 862-868.
- Griffin, J.R. 1973. **Valley oaks—the end of an era?** Fremontia 1(1): 5-9.
- Griffin, J.R. 1976. **Regeneration in *Quercus lobata* savannas, Santa Lucia Mountains, California**. The American Midland Naturalist 95(2): 422-435.
- Griggs, F.T.; Peterson, D.R. 1997. **Evaluation of techniques and costs for valley oak riparian forest restoration on the Sacramento River**. In: Pillsbury, N.H.; Verner, J.; Tietje, W.D., technical coordinators. Proceedings of a symposium on oak woodlands: ecology, management, and urban interface issues; 1996 March 19-22; San Luis Obispo, CA. Gen. Tech. Rep. PSW-GTR-160. Albany, CA: Pacific Southwest Research Station, Forest Service, U.S. Department of Agriculture; 289-295.
- Holmes, T.H. 1990. **Botanical trends in northern California oak woodland**. Rangelands 12(1): 3-7.
- Jepson, W.L. 1910. **The silva of California**. Memoirs of the University of California Vol. 2. Berkeley, CA: The University Press; 480 p.
- Lake County. 1995. **Resolution adopting a management policy for oak woodlands in Lake County**. Board of Supervisors Resolution No. 95-211.
- Lake County. 2001. **Five year assessment of the conditions of oak woodlands in Lake County March 23, 2001**. Report by the Biological Resource Sub-committee of the Lake County Resource Management Committee; 5 p.
- Lathrop, E.W.; Osborne, C.D. 1990. **From acorn to tree: ecology of the Engelmann oak**. Fremontia 18(3): 30-35.
- Leider, A., Senior Planner, Santa Barbara County Planning and Development Department. [Telephone conversation with Rudolph H. Light]. 11 July 2001.
- Lichtenstein, S.; Slovic, P.; Fischhoff, B.; Layman, M.; Combs, B. 1978. **Judged frequency of lethal events**. Journal of Experimental Psychology: Human Learning and Memory 4(6): 551-578.

- Light, R.H. 1983. **Understanding aerophobia: cognitive, emotional and personality aspects**. San Diego, CA: California School of Professional Psychology; 199 p. Ph.D. dissertation.
- Light, R.H.; Buckner, T.R. 1999. **Irrigation and rangeland oaks**. In: McCreary, D.D., ed. Proceedings of the second international oak conference; 1997 October; San Marino, CA. The Journal of the International Oak Society No. 9. Auburn, IL: International Oak Society; 84-93.
- Los Angeles County. 1993. **Oak tree permits**. Part 16, Title 22, Chapter 22.56.
- Madera County. 1999. **Voluntary oak-woodland management guidelines**. Eastern Madera County Coarsegold Resource Conservation District. 5p.
- Marin County Community Development Agency. 1996. **Memorandum regarding the tree preservation ordinance workshop from K. Hansen to Marin County Planning Commission, 4 November 1996**; Marin County Community Development Agency; 7 p.
- Marin County Community Development Agency. 1999. **Native tree preservation and protection**, Ordinance No. 3291, Chapter 22.83.
- Mariposa County. 1995. **Voluntary oak-woodland management guidelines**. Mariposa County Resource Conservation District. 13 p.
- McClaran, M.P., 1987. **Yearly variation of blue oak seedling emergence in northern California**. In: Plumb, T.R.; Pillsbury, N.H., technical coordinators. Proceedings of the symposium on multiple-use management of California's hardwood resources; 1986 November 12-14; San Luis Obispo, CA. Gen. Tech. Rep. PSW-100. Berkeley, CA: Pacific Southwest Forest and Range Experiment Station, Forest Service, U.S. Department of Agriculture; 76-78.
- McClaran, M.P.; Bartolome, J.W. 1989. **Fire-related recruitment in stagnant *Quercus douglasii* populations**. Canadian Journal of Forestry Resources 19: 580-585.
- McCreary, D.D. 1989. **Regenerating native oaks in California**. California Agriculture 43(1): 4-6.
- McCreary, D.D. 1990. **Blue oaks withstand drought**. California Agriculture 44(2): 15-17.
- McCreary, D.D. 2001. **Regenerating rangeland oaks in California**. University of California Agriculture and Natural Resources Publication 21601; 62 p.
- Mensing, S.A. 1992. **The impact of European settlement on blue oak (*Quercus douglasii*) regeneration and recruitment in the Tehachapi Mountains, California**. Madroño 39(1): 36-46.
- Monterey County. 1997. **Preservation of oak and other protected trees**. Title 21, Section 24.64.260.
- Muick, P.; Bartolome, J.W. 1987. **An assessment of natural regeneration of oaks in California**. Sacramento, CA: California Department of Forestry, The Forest and Rangeland Resource Assessment Program; 100 p.
- Napa County. 1999. **Conservation regulations**. Title 18, Chapter 18.108.
- Nevada County. 2000. **Trees**. Land Use Code Chap. II, Ordinance No. 2033, Article 4, L-II 4.3.15.
- Panheco, A.A. 1987. **Some implications of public involvement in hardwood management**. In: Plumb, T.R.; Pillsbury, N.H., technical coordinators. Proceedings of the symposium on multiple-use management of California's hardwood resources; 1986 November 12-14; San Luis Obispo, CA. Gen. Tech. Rep. PSW-100. Berkeley, CA: Pacific Southwest Forest and Range Experiment Station, Forest Service, U.S. Department of Agriculture; 144-147.

- Peña, M. 2000a. **Losing deep roots**. San Francisco Chronicle 19 October 2000. A21.
- Peña, M. 2000b. **Danville oaks cage to catch beloved tree**. San Francisco Chronicle 24 November 2000.
- Placer County. 1996. **Tree preservation generally**. Chapter 12, Article 12.16.
- Plumb, T.R.; De Lasaux, M.D. 1997. **An evaluation of coast live oak regeneration techniques**. In: Pillsbury, N.H.; Verner, J.; Tietje, W.D., technical coordinators. Proceedings of a symposium on oak woodlands: ecology, management, and urban interface issues; 1996 March 19-22; San Luis Obispo, CA. Gen. Tech. Rep. PSW-GTR-160. Albany, CA: Pacific Southwest Research Station, Forest Service, U.S. Department of Agriculture; 231-242.
- Plumb, T.R.; Pillsbury, N.H., technical coordinators. 1987. **Proceedings of the symposium on multiple-use management of California's hardwood resources; November 12-14, 1986, San Luis Obispo, CA**. Gen. Tech. Rep. PSW-100. Berkeley, CA: Pacific Southwest Forest and Range Experiment Station, Forest Service, U.S. Department of Agriculture; 463 p.
- Riverside County. 1997. **An ordinance of the County of Riverside amending ordinance No. 559 regulating the removal of trees**. Ordinance No. 559.7
- Roberts, T.A.; Smith, C.H. 1982. **Growth and survival of black oak seedlings under different germination, watering, and planting regimes**. Tree Planters' Notes 33(4): 10-12.
- Rossi, R.S. 1990. **Oak ordinances: do they help or hurt?** Fremontia 18(3): 96-98.
- San Luis Obispo. 1995. **Tree removal**. Coastal Zone Land Use Ordinance 23.05.
- Santa Barbara County. 2001. **Oak tree protection program: final environmental impact report 00-EIR-07 and proposed Oak Tree Protection Ordinance Chapter 35, Article IX**. Santa Barbara County Planning and Development Department.
- Santa Clara County. 1995. **Preserving oak trees: Quick reference mitigations for planning staff**. U.C. Cooperative Extension and Santa Clara County Department of Planning and Development; 13 p.
- Santa Clara County. 1997. **Tree preservation and removal**. Division C16, Ordinance No. NS-1203.107.
- Schettler, S.; Smith, M.N. 1980. **Nursery propagation of California oaks**. In: Plumb, T.R., technical coordinator. Proceedings of the symposium on the ecology, management, and utilization of California oaks; 1979 June 26-28; Claremont, CA. Gen. Tech. Rep. PSW-44. Berkeley, CA: Pacific Southwest Forest and Range Experiment Station, Forest Service, U.S. Department of Agriculture; 143-148.
- Schott, T. District Conservationist, Natural Resources Conservation Services for Mendocino County. [Telephone conversation with Rudolph H. Light]. 26 July 2001.
- Shasta County. 1995. **Resolution adopting oak woodland management guidelines**. Board of Supervisors Resolution No. 95-157.
- Slovic, P.; Fischhoff, B.; Lichtenstein, S. 1976. **Cognitive processes and societal risk taking**. In: Carroll, J.S.; Payne, J.W., eds. Cognition and social behavior. Potomac, MD: Lawrence Erlbaum Assoc.; 165-184.
- Sonoma County. 1989. **Tree protection and replacement**. Ordinance No. 4014.
- Sonoma County. 1997. **Valley oak habitat**. Ordinance No. 4991.
- Standiford, R.B, technical coordinator. 1991. **Proceedings of the symposium on oak woodlands and hardwood rangeland management; October 31-November 2, 1990**;



When Oak Ordinances Fail—Light and Pedroni

- Davis, CA. Gen. Tech. Rep. PSW-126. Berkeley, CA: Pacific Southwest Research Station, Forest Service, U.S. Department of Agriculture; 376 p.
- Standiford, R.B.; Bartolome, J. 1997. **The integrated hardwood range management program: education and research as a conservation strategy.** In: Pillsbury, N.H.; Verner, J.; Tietje, W.D., technical coordinators. Proceedings of a symposium on oak woodlands: ecology, management, and urban interface issues; 1996 March 19-22; San Luis Obispo, CA. Gen. Tech. Rep. PSW-GTR-160. Albany, CA: Pacific Southwest Research Station, Forest Service, U.S. Department of Agriculture; 569-581.
- Standiford, R.B.; McCreary, D.; Barry, S.; Forero, L.; Knight, R. 1996. **Impact of firewood harvesting on hardwood rangelands varies with region.** California Agriculture 50(2): 7-12.
- Standiford, R.; McDougald, N.; Phillips, R.; Nelson, A. 1991. **South Sierra oak regeneration weak in sapling stage.** California Agriculture 45(2): 12-14.
- Standiford, R.B.; Tietje, W.D.; LeBlanc, J.W.; Weitkamp, W.H. 1990. **Harvesting firewood for sustained yield on oak rangelands.** University of California Agriculture and Natural Resources Publication 21487; 29 p.
- Steinhart, P. 1978. **As the old oaks fall.** Audubon 80(5): 30-40.
- Strong, G.; George, A. 1990. **Visalia is saving its valley oaks.** Fremontia 18(3): 99-100.
- Sudworth, G.B. 1908 (1967 Reprint). **Forest trees of the pacific slope.** New York: Dover Publications; 455 p.
- Swiecki, T.J.; Bernhardt, E.A.; Drake, C. 1993. **Factors affecting blue oak sapling recruitment and regeneration.** Report to California Department of Forestry and Fire Protection, Strategic Planning Program; 132 p.
- Tehama County. 1994. **A resolution adopting oak woodland management guidelines.** Board of Supervisors Resolution No. 57-1994.
- Trinidad, A. Development Review Staff, San Luis Obispo County Department of Planning and Building. [Telephone conversation with Rudolph H. Light]. 3 July 2001.
- Tuolumne County. 1995. **A resolution adopting oak woodland voluntary management guidelines.** Board of Supervisors Resolution No. 215-95.
- Tversky, A.; Kahneman, D. 1971. **Belief in the law of small numbers.** Psychological Review 76: 105-110.
- Tversky, A.; Kahneman, D. 1974. **Judgment under uncertainty: heuristics and biases.** Science 185: 1124-1131.
- Welker, J.M.; Menke, J.W. 1990. **The influence of simulated browsing on tissue water relations, growth and survival of *Quercus douglasii* (Hook and Arn.) seedlings under slow and rapid rates of soil drought.** Functional Ecology 4: 807-817.
- White, K.L. 1966. **Structure and composition of foothill woodland in central coastal California.** Ecology 47(2): 229-237.
- Wright, H.A.; Bailey, A.W. 1982. **Fire ecology, United States and Southern Canada.** New York: John Wiley & Sons; 501 p.
- Yuba County. 1996. **Conservation of oak woodlands.** Yuba County General Plan: Land Use, Circulation, Open Space and Conservation Elements, Section 7-OSCG.

February 22, 2016

Mr. Scott Wilson  
Acting Regional Manager, Bay Delta Region  
California Department of Fish and Wildlife (CDFW)  
7329 Silverado Trail  
Napa, CA 94558  
cc: [scott.wilson@wildlife.ca.gov](mailto:scott.wilson@wildlife.ca.gov)

**Re: East Bay Zoological Society "California Trail" project – Violations of CDFW Incidental Take Permit**

Dear Mr. Wilson:

We alerted your Department on September 3, 2015 to significant violations of the California Department of Fish and Wildlife (CDFW) Incidental Take Permit granted to the East Bay Zoological Society (EBZS) for its "California Trail" project now being constructed on the ridgeline of Oakland's Knowland Park. Unfortunately, the permit violations and habitat damage continued well beyond what we documented in that initial complaint.

The CDFW Incidental Take Permit (ITP) covers a major development project in 56 acres of parkland recognized for its critical habitat for the threatened Alameda striped racer and rare California native grasslands. When you granted EBZS permission to build within a sensitive park area, EBZS gave assurances to the public that the environmental protections built into their permits would be followed.

However, park visitors have noticed general disregard for several significant environmental requirements in the CDFW permit, as well as in other permits for this project—and construction is only in its early phases. We are reporting at least one acre of unpermitted damage that could be observed and documented through September 2015. EBZS consultants responsible for on-site monitoring and the City as lead agency for permit oversight did not intervene to stop the habitat damage we are reporting.

With this letter of complaint, we request that CDFW take actions in the following **four areas** to ensure that EBZS complies with the conditions of their Incidental Take Permit (ITP):

- **Require EBZS to submit legible baseline documents that specifically show the locations of protected native grassland, permitted damage, and actual damage to date**
- **Require prompt repair of habitat damage from fence construction**
- **Enforce the permit provisions for control of invasive weeds**
- **Implement independent monitoring to ensure ongoing EBZS permit compliance**

This letter includes these sections:

- I. Background of environmental requirements for building in Knowland Park highlands
- II. Permit requirements and actual EBZS compliance: July – September, 2015
- III. Requested CDFW actions
- IV. Supporting exhibits

## I. Background of environmental requirements for building in Knowland Park highlands

For decades, Knowland Park has brought children and adults into direct contact with our state's native plant communities, birds, and free-roaming wildlife. Knowland Park is an ecological treasure, a living classroom, and an urban retreat for the public. In addition to hosting 44 locally rare plant species, the park features original maritime chaparral and native bunchgrass prairie, both of which are critical habitat for the threatened Alameda striped racer (**ASR**) and rare within California. With *less than one percent* of native California grasslands remaining in our state, Knowland Park features a diversity of native grassland species that have established and survived on this site over hundreds of years.

In July 2015, East Bay Zoological Society, the contracted operator of the Oakland Zoo, began construction of a "California Trail" exhibit uphill from the Zoo in the Knowland Park highlands. In public hearings over five years, Zoo consultants, staff, and trustees repeatedly assured elected officials and the public that any development-related damage to rare flora and wildlife habitat would be negligible, because they would be following strict regulatory requirements prescribed in the CDFW Incidental Take Permit, the US Fish and Wildlife Service Biological Opinion, and the City-approved "Habitat Enhancement Plan" (**HEP**) that was written by EBZS and included in the City-approved Supplemental Mitigated Negative Declaration/Addendum (**SMND/A**) for the project. EBZS management promised to hold themselves to exemplary standards during construction, in the interest of protecting the rare and unique natural resources of Knowland Park.

The US Fish and Wildlife Service (**USFWS**), California Department of Fish and Wildlife, and the US Army Corps of Engineers (**USACE**) subsequently gave final approval to permits that included a range of conditional habitat protection measures and a conservation easement required for the project to proceed. The environmental protections apply to the pre-construction, construction, and post-construction stages for this project.

Despite these environmental requirements, site damage began in late July 2015 during the installation of the perimeter fence and wildlife exclusion fence, on State-recognized rare native grasslands proposed by EBZS and accepted by the environmental regulatory agencies as critical foraging and dispersal habitat for the Alameda striped racer. The damage is in direct violation of multiple provisions of the CDFW Incidental Take Permit (detailed in Section II of this complaint).

EBZS expert consultants who are responsible for on-site monitoring were supposed to stop work if sensitive areas were being damaged. They did not. A second level of construction monitoring by the City—as the lead agency for regulatory permit oversight and as the building permit enforcer—also failed to halt permit violations. Noticing the disregard for protected parkland, Oakland citizens and environmental organization volunteers documented and reported these violations. On September 3, 2015, we sent a letter to the Oakland City Planning Department, alerting them to violations of environmental protections under the City's building permit for the perimeter fence, with copies to CDFW, USFWS, USACE, and Regional Water Quality Control Board (**RWQCB**).

Unfortunately, the City's response does not bode well for conservation of Alameda striped racer habitat and rare California flora. In their reply dated September 16, 2015 and copied to your agency,

the City Planning Department acknowledges that parkland and habitat were damaged by EBZS construction. (**Figure 1.**) However, they contend that the environmental protections in the building permit – many mirroring the conditions for approval in your ITP – are not really regulatory *requirements*; instead, the City implies these protections are voluntary. An EBZS response that accompanied the City's letter takes the same unobligated approach, seeks to divert attention from the damage, and waters down the need for EBZS to comply with the requirements of their environmental permits.



**Figure 1.** Example of unauthorized damage to former rare native grassland and Alameda striped racer habitat torn up during construction of perimeter fence (*left*) and wildlife exclusion fence (*right*).

**Note:** While photos used throughout this complaint show areas of damage to seasonally dormant (straw-colored) native grasses and forbs, in other seasons, the native bunchgrasses turn green, the wildflowers bloom, and these areas support a diversity of life.

Current local self-policing for this project is not reliable. Agreed-upon environmental protections are being ignored, even though the elements of the permit are well known to all parties. Permit details were hashed out between CDFW and EBZS, with EBZS contributing many of them. These protections have been touted repeatedly by EBZS and their professional consultants in public meetings for half a decade.

The City Planning Department's lenient response to EBZS's non-compliance raises a serious question of whether the City has already effectively forfeited its role as the lead agency for permit oversight. Based on documentation in Section II of this complaint, sufficient action is now needed from your Department to enforce the CDFW permit.

## II. Permit requirements and actual EBZS compliance: July – September, 2015

Following is a numbered list of certain regulatory and City permit conditions agreed to by the East Bay Zoological Society (permittee) and the City of Oakland (permit lead agency), each item with a summary of actual EBZS compliance. Source documents and references are cited. Reference to lettered locations at the site correspond to the same letters used in the EBZS building permit plans to label site areas for the perimeter fence.

Unpermitted site damage that is visible from the boundaries of the perimeter fence is clearly underestimated to be at least one acre of public parkland. The condition of habitat and native grassland in other areas further inside the construction zone is unknown to the public. There are 13 EBZS violations of permit conditions listed as follows:

### 1. PERMIT CONDITION: Identify areas of Alameda striped racer habitat and protected native grasslands, and follow basic protective measures to avoid and preserve those sensitive areas.

#### a. REQUIRED: Delineate locations of “protected native grasslands” on the building plans.

*EBZS COMPLIANCE: Disregarded*

Both the USFWS Biological Opinion and the City/EBZS Habitat Enhancement Plan require EBZS to delineate the locations of “protected native grasslands” on all building plans for contracted workers to know there are grasslands to be protected and where they are located, so they can avoid damage to these sensitive areas.

The “Supplemental Grassland Mapping” (see Attachment 1A) that was approved by the City Council on November 18, 2014 showed the areas of State-recognized rare native grasslands within or adjacent to the project site. However, **no native grasslands were marked for protection in the building plans** submitted by EBZS for their perimeter fence building permit (#GR1500068 – #PZ1500051). General mention is made of native grasslands in the plan’s text comments, but no native grasslands are mapped and labeled as “protected.” (see Attachment 1B)

By omitting the delineation of “protected native grasslands” in the building plans, the developer (EBZS) **has essentially indicated to the contractors that there are none**. As a result, there has been substantial damage to Alameda striped racer habitat and protected native grasslands at the site.

Neglect of this basic protective measure continued. The temporary access road plan submitted by EBZS and approved by the City (building permit #GR1500100) also omits any designation or mapping of “protected native grasslands.”

#### Source documents:

- USFWS, Biological Opinion, p. 12, number 31a

- Supplemental Mitigated Negative Declaration/Addendum (SMND/A), Habitat Enhancement Plan (HEP), “Implementing Action 2–6,” p. 14, developed by EBZS and approved by City
- Attachment 1A – EBZS and City “Supplemental Grassland Mapping” (11-18-14)

#### Documentation of violation:

“Protected native grasslands” were not identified in:

- EBZS Building Permit #GR1500068 – #PZ1500051, p. PF-3 (Permit plans not released; viewable only at City Planning and Building office)
- EBZS Building Permit #GR15000100 (Permit plans not released; viewable only at City Planning and Building office)
- Attachment 1B – EBZS Storm Water Pollution Protection Plan submitted to Regional Water Quality Control Board

### b. REQUIRED: Stands of protected native grasslands shall be marked in the field and protective fencing installed prior to construction.

*EBZS COMPLIANCE: Disregarded*

In addition to being required to detail the locations of State-recognized rare native grasslands on the building plans, EBZS was supposed to mark these stands in the field with temporary protective fencing prior to construction. However, construction of the perimeter fence and wildlife exclusion fence was started in the last week of July 2015 without any protective fencing in place to alert contractors that there were protected rare native grassland stands to avoid.

**Figure 2.** Knowland Park hillside immediately above Zoo with approximately 530 linear feet (estimated .41 acres) of unpermitted damage to protected grassland from construction equipment. Extensive soil-tear on both development and public sides of perimeter fence. Use of equipment here (Site Areas C–D) is prohibited by both CDFW and City permits. **Complaint sections 1a–e, h, 2a, c, d.**



As a result, damage occurred. (Figure 2.) A few flimsy signs marked "CE" (i.e., "conservation easement") appeared on the site later, but well after widespread damage had been done to Alameda striped racer habitat and protected native grasslands.

This area is part of the conservation easement that CDFW accepted as mitigation for EBZS permanently eliminating existing areas of Covered Species' (Alameda striped racer) habitat. The conservation easement is designated to be a protected area, but no protections were applied.

**Source documents:**

- CDFW ITP, Section 7.6 "Vegetation Marked for Protection," p. 14
- CDFW ITP, Section 6.3 "Compliance Monitoring," p. 11
- USFWS Biological Opinion, p. 12, number 31b
- Supplemental Mitigated Negative Declaration/Addendum (SMND/A), Habitat Enhancement Plan (HEP), "Implementing Action 2-6," pp. 14-15, developed by EBZS and approved by City
- Attachment 1A – EBZS and City "Supplemental Grassland Mapping"

**Documentation of violation:** Figures 1-7 photos

- c. REQUIRED: No vehicles are allowed to cross Covered Species' (Alameda striped racer) habitat.**  
*EBZS COMPLIANCE: Disregarded*

**Figure 3. (left)** Off-road equipment tracking and damage on protected native grassland and Alameda striped racer habitat above Zoo's veterinary hospital (Site Areas C-D). Estimated .10 acres of unpermitted damage to public parkland. **(right):** EBZS construction vehicles being driven freely over protected rare native grasslands and ASR habitat in clear violation of EBZS permits. **Complaint sections 1a-e, g, h, 2a-d.**



Under the ITP and the City building permit, equipment is not permitted on Covered Species' (Alameda striped racer) habitat. Nevertheless, construction equipment has regularly trafficked across and damaged Covered Species' habitat and State-recognized rare native grasslands. Torn soils and equipment tracks were evident off-road in the project area, and also outside the project area in land that remains open public parkland. (Figure 3, Figure 4.)

**Source documents:**

- CDFW ITP, Section 5.11 "Project Access" – vehicles and construction equipment shall stay on established roads
- CDFW ITP, Section 6.3 "Compliance Monitoring," p. 11
- City Building Permits #GR1500068 – #PZ1500051, p. PF-3 – prohibits "circular routes off working strip" (Permit plans not released; viewable only at City Planning and Building office)

**Documentation of violation:** Figures 1-7 photos

**Figure 4.** Southeast ridge (Site Areas E-E1) with approximately 40 linear feet x 25 feet = estimated .02 acres of unauthorized construction equipment damage to public parkland and protected native grassland outside development footprint. **Complaint sections 1a-d, f, h, 2a, c, d.**



- d. REQUIRED: Perimeter fence is to be installed manually to avoid habitat damage and harm to Alameda striped racer.**

*EBZS COMPLIANCE: Disregarded*

The CDFW permit specifically requires the entire perimeter fence to be constructed "by hand with minimum vegetation clearing, and alignment adjusted to avoid tree trunks and other sensitive vegetation." Instead, EBZS used tractor equipment extensively for both the perimeter fence and wildlife exclusion fence. Use of this equipment resulted in significant site damage.

**Source documents:**

- CDFW ITP, "Perimeter Fence," pp. 3–4
- CDFW ITP, Section 6.3 "Compliance Monitoring," p. 11
- Attachment 1C – Layout of EBZS perimeter fence
- Attachment 1D – Overview of ASR habitat/protected rare native grasslands damaged by EBZS construction in violation of environmental permits

**Documentation of violation:** Figures 2, 3, 4, 5, 7 photos

- e. **REQUIRED: City building permit requires site areas "C–D" of the perimeter fence to be installed manually to avoid site damage.**

*EBZS COMPLIANCE: Disregarded*

Contrary to the CDFW ITP requirement that the *entire* perimeter fence be installed manually, EBZS submitted their request for a City building permit that required manual installation only for a limited portion of the fence on the hillside above the veterinary hospital, identified as site areas C–D in the EBZS perimeter fence permit plans, and the City approved it. This is part of the "conservation easement" area accepted by CDFW to mitigate for EBZS destruction of adjacent Alameda striped racer habitat in this project.

But instead of manual installation, EBZS allowed tractor equipment to drive undeterred across this conservation easement area, with no intervention by City building inspectors or the on-site EBZS biological monitors charged with ensuring permit compliance. Use of this equipment resulted in extensive site damage.

**Source documents:**

- City Building Permits #GR1500068 – #PZ1500051, p. PF-3 for perimeter fence (Permit plans not released; only viewable at City Planning and Building office)
- CDFW ITP, "Perimeter Fence," pp. 3–4
- CDFW ITP, Section 6.3 "Compliance Monitoring," p. 11
- Attachment 1C – Layout of EBZS perimeter fence
- Attachment 1D – Overview of ASR habitat/protected rare native grasslands damaged by EBZS construction in violation of environmental permits

**Documentation of violation:** Figures 2, 3 photos

- f. **REQUIRED: City building permit allows soil disturbance to a maximum of 5-feet wide along remainder of perimeter fence in site areas "D–F."**

*EBZS COMPLIANCE: Disregarded*

Although the ITP required manual construction for the perimeter fence, the City omitted this regulatory condition and instead approved a building permit allowing soil disturbance within

five feet of both sides of the perimeter fence line (site areas D–F in the perimeter fence building permit). But even with a lower standard of environmental protection, EBZS did not comply. In **Figure 5**, tire damage from tractor equipment is evident up to 30 feet on each side of the fence. This violation was not stopped by City building inspectors or by on-site EBZS biological monitors charged with ensuring permit compliance.

**Figure 5.** Unauthorized damage by equipment to public parkland and protected native grassland along perimeter fence, outside of project footprint. Top of southeast-facing fence (Site Areas E1–E2) – approximately 30 linear feet x 30 feet = estimated .02 acres of damage. **Complaint sections 1a–d, f, h; 2a, c, d.**



**Source documents:**

- City Building Permits #GR1500068 – #PZ1500051 for perimeter fence (Permit plans not released; only viewable at City Planning and Building office)
- CDFW ITP, "Perimeter Fence," pp. 3–4
- CDFW ITP, Section 6.3 "Compliance Monitoring," p. 11
- Attachment 1C – Layout of EBZS perimeter fence
- Attachment 1D – Overview of ASR habitat/protected rare native grasslands damaged by EBZS construction in violation of environmental permits

**Documentation of violation:** Figures 3, 4, 5, 7 photos

**g. REQUIRED: Identify native grassland to be protected from construction damage, including wildlife exclusion fence installation.**

*EBZS COMPLIANCE: Disregarded*

The materials and methods EBZS used to install the wildlife exclusion fence led to trenching and scraping of sensitive native grassland identified as protected in the “Supplemental Grassland



**Figure 6.** (top) EBZS trenching and scraping damage across original and intact native bunchgrass prairie for the wildlife exclusion fence. (Site Areas D–E). Approximately 1,700 linear feet x 7 feet = estimated .27 acres damage outside of project footprint. **Complaint sections 1a–c, g, h; 2b, c, d.** (bottom) Another example of the damaging method used to install the wildlife exclusion fence.

Mapping” of the SMND/A. (Figure 6.) Such permanent damage to this native grassland could have been avoided in two ways: 1) by taking the time needed to install the fence properly rather than sacrifice environmental protections for quick-and-dirty construction expedience, or 2) by using an available alternative fencing product specifically designed to eliminate the need for destructive trenching (see Attachment 2).

**Source documents:**

- CDFW ITP, Section 7.6 “Vegetation Marked for Protection,” p. 14
- Supplemental Mitigated Negative Declaration/Addendum (SMND/A), Habitat Enhancement Plan (HEP), “Implementing Action 2–1,” pp. 12–13
- Supplemental Mitigated Negative Declaration/Addendum (SMND/A), Habitat Enhancement Plan (HEP), “Implementing Action 2–6,” pp. 14–15

**Documentation of violation:** Figure 6 photo

**h. REQUIRED: Comply with Regional Water Quality Control Board’s storm water permit requirements and standard practices for protection of existing vegetation.**

*EBZS COMPLIANCE: Disregarded*

EBZS’s concern for expedient construction was allowed to trump standard and common sense practices of vegetation protection, as described earlier and in photos, even though EBZS indicated they would follow these standards by submitting them with their erosion control plan (see Attachment 3).

The Regional Water Quality Control Board’s Storm Water Pollution Prevention Plan requirements mirror both the ITP and the USFWS Biological Opinion conditions for approval by requiring protection of existing vegetation. To prevent erosion, the Regional Water Quality Control Board’s “Preservation of Existing Vegetation EC-2” standard practices state that natural vegetation is to be designated on plans, and marked for protection in the field, especially on steep hillsides.

**Source documents:**

- USFWS Biological Opinion, number 18, p. 8
- CDFW ITP, Section 2 “Legal Compliance,” p. 7
- Attachment 3 – Preservation of Existing Vegetation EC-2 standard practices

**Documentation of violation:** Figures 1–7 photos

**2. PERMIT CONDITION: Compliance with ITP should be monitored on-site daily, with proper and timely notifications to CDFW.**

**a. REQUIRED: Permittee will notify CDFW 14 days in advance of starting work on the California Trail construction.**

*EBZS COMPLIANCE: Disregarded*

EBZS failed to notify CDFW before starting construction work, as confirmed in a phone inquiry to CDFW staff. The State was not aware that work was underway, nor was the public until they began to notice the damage already occurring on protected grasslands.

**Source document:**

- CDFW ITP, Section 6.1 "Notification Before Commencement," p. 11

**b. REQUIRED: Permittee will submit notice of the location and design of the wildlife exclusion fence for CDFW review 30 days in advance of the start of installation.**

*EBZS COMPLIANCE: Disregarded*

Per phone inquiry to CDFW staff, description of the location and design of the wildlife exclusion fence was submitted three days prior to the start of installation, rather than the required 30 days. CDFW had no time to review EBZS plans so that any risk of unnecessary damage might be identified and averted.

As described and documented earlier (Section II, 1g), EBZS's choice for the wildlife exclusion fence materials and the methods used to install it have caused significant damage to protected rare native grassland and Alameda striped racer habitat.

**Source document:**

- CDFW ITP, Section 7.5 "Temporary Covered Species Barrier," p. 14

**c. REQUIRED: Designated biologist shall monitor for compliance with all measures of this ITP.**

*EBZS COMPLIANCE: Disregarded*

Designated EBZS biologist should be on-site daily when 'Covered Activities' occur, to conduct compliance inspections to:

- Minimize incidental take of the Covered Species
- Prevent unlawful take of species
- Check for compliance with *all* measures of this ITP
- Check all exclusion zones

- Ensure that signs, stakes, and fencing are intact, and that Covered Activities are only occurring in the project area

**Source document:**

- CDFW ITP, Section 6.3 "Compliance Monitoring," p. 11

**Documentation of violation:** Figures 1–8 photos

**d. Permittee will send notification of non-compliance to CDFW.**

*EBZS and CITY COMPLIANCE: Disregarded*

None of the agents entrusted to monitor construction and enforce permit requirements (not the EBZS on-site biological monitors, the supervising City building inspector as lead agency, nor EBZS management as the project permittee and "designated representative") notified CDFW when habitat damage started above the veterinary hospital or as it continued. It was Oakland citizens and environmental organization volunteers concerned for the park's natural resources who notified the City Planning and Building Department and the regulatory agencies about EBZS's failure to comply with conditions of approval. (Figure 7.)

**Source document:**

- CDFW ITP, Section 6.2 "Notification of Non-compliance," p. 11

**Documentation of violation:** Figures 1–7 photos

**Figure 7.** Unauthorized damage by prohibited equipment to protected native grassland along east-facing perimeter fence in public parkland outside the development footprint (Site Areas E2–F). Approximately 450 linear feet x 25' = estimated .26 acres. **Complaint sections 1a–d, f, h; 2a, c, d.**



**3. PERMIT CONDITION: Implement invasive weed control at commencement of ‘Covered Activities’ (i.e., construction activities).**

*EBZS COMPLIANCE: Disregarded*

According to the ITP, high- and moderate-rated invasive weed species that threaten wildlands in California shall be removed and prevented from re-establishing during this project.

There is no evidence of any weed control effort by EBZS, despite the permit requirement and the potential of these weeds to degrade substantial portions of the conservation easement, and even the entire park.

**Figure 8.** Left unattended, invading stinkwort (*Dittrichia graveolens*) in Knowland Park is moving up the north access fire road from Golf Links Road, with untreated broom (*Genista monspessulana*) behind it. (October 2015) **Complaint sections 2c, 3.**



Since July 2015, when project construction began, not only have small areas of invasive broom gone unattended, but a new invasive weed, stinkwort (*Dittrichia graveolens*), has been making inroads into the park via disturbed areas. This new, harmful weed remained unattended in 2015, despite the permit requirements to control invasive weeds when ‘Covered Activities’ commenced.

Stinkwort is noxious and has the potential to take over the disturbed soil surfaces, in addition to the fire roads scraped by the City over the years. Stinkwort has been implicated in livestock deaths, and therefore may pose harm to grazing wildlife. (Figure 8.)

**Source document:**

- CDFW ITP, Section 7.11 “Invasive Species,” pp. 15–16
- CDFW ITP, Section 6.3 “Compliance Monitoring,” p. 11

**Documentation of violation:** Figure 8 photo

**III. Requested CDFW actions**

We ask CDFW to confirm that protections under the CDFW Incidental Take Permit for sensitive native grassland and Alameda striped racer habitat are required, not discretionary. We also request that you report your findings on the EBZS violations noted in this complaint.

We ask you to enforce the requirements and intent of the Incidental Take Permit (ITP) you have granted to EBZS by taking actions in these **four areas**:

1. Require EBZS to submit legible baseline documents that specifically show the locations of protected native grassland, permitted damage, and actual damage to date.
  - a. Require EBZS to clearly map the protected native grasslands on all active and future construction plans, and mark them in the field, per explicit requirements of the permits.
  - b. Require EBZS to clearly designate the areas of permitted damage, as well as actual damage to date (permitted and unpermitted).

The public has been provided a nearly illegible map (see Attachment A) that does not adequately identify where CDFW and USFWS will allow permanent and “temporary” damage to native grasslands and Alameda striped racer habitat. It does not specify the acreage of these permitted areas that could then be used to measure and track permit compliance. (Note: EBZS is capable of providing legible site drawings, as evidenced in Attachment 1B – an example of mapping they submitted for their RWQCB erosion control plan).

CDFW should require EBZS to produce a legible map and spreadsheet to:

- Identify the projected 4.36 acres of native grassland permitted to be lost during construction
- Specify where the permit allows *permanent* and *temporary* damage (i.e., “disturbance zones” discussed in the SMND/A – Habitat Enhancement Plan)
- Detail the locations and acreage of the *unpermitted* damage in a report available to the public



EBZS should provide this information to CDFW to fully comply with their ITP annual report of January 31, 2016 (ITP, Section 6.5, "Annual Status Report"), and as indicated in monthly compliance reports (ITP, Section 6.4, "Monthly Compliance Report").

**2. Require prompt repair of habitat damage from fence construction.**

At least one acre of visible, unauthorized habitat loss has resulted from the construction methods EBZS used to install both the perimeter fence and wildlife exclusion fence (see Attachment 1D).

**a. Repair the temporary and the unpermitted damages from perimeter fence construction.**

The ITP allows for specified "temporary impacts" and "permanent impacts," and has provisions for addressing them. However, habitat damage from permit violations may result in the stopping of work for 25 days or longer, or suspension or cancellation of the permit.

The "Temporary Impacts" section (ITP Sections 6.9–6.10) states that the "permittee shall restore on-site the 4.36 acres of 'Covered Species' habitat that will be temporarily disturbed during construction to pre-project or better conditions." It specifies that all areas temporarily disturbed are to be repaired by October 31 of the year they are disturbed or "the permittee shall be responsible for providing additional mitigation," including native grassland restoration at a 3:1 ratio. There is no evidence that the habitat damaged from July through September 2015 was repaired by the end of October 2015. Therefore, the acreage must be repaired by next October **with the addition of mitigation measures.**

Since there have been unpermitted impacts, sanctions are needed as a penalty for violating permits, and as incentive for EBZS to comply in the future. Sanctions should *directly benefit the site*. In particular, the native prairie damaged outside the perimeter fence and in the Alameda striped racer "conservation easement" should be restored at a 3:1 ratio to the full suite of background native grass and forb species indigenous to this site, as listed in the 2011 Lake inventory (see Attachment 4). Seeds and seedling plugs should come from seed collected on-site. The City building permit states that the native grassland and forb prairie unduly disturbed by perimeter fence construction will be "replaced by owner and back charged to contractor at the cost to plug plant at a minimum of \$1.15 per sq. ft."

Invasive non-native weeds that are introduced or spread due to the disturbed soil conditions should be completely eradicated, starting now with the 2016 rainy season.

If all applicable areas are not replanted by **October 31, 2016**, the CDFW should suspend or withdraw their permit until all permit conditions for approval and park-benefitting sanctions are met.

An EBZS "Vegetation Restoration Plan" was due to CDFW six months after the ITP was issued (CDFW ITP, Section 8.6 "Habitat Restoration"). That plan should now be updated to include these site-beneficial sanctions.

**b. Repair unpermitted damage resulting from how the wildlife exclusion fence was installed.**

The area excessively damaged by the wildlife exclusion fence construction, especially the fencing outside the perimeter fence, needs to be promptly repaired. In particular, CDFW should require EBZS to submit a plan to relocate and reconstruct a wildlife exclusion fence that does not damage the area shown in Figure 6 and Attachment 1D, Site Areas D–E.

In addition, the seven-foot-wide band of grassland that was scraped along the full length of the wildlife exclusion fence is unpermitted damage. The method used to install this fencing was for construction expedience, with no regard for the protections in the permits for Alameda striped racer habitat or the protected native grasslands. Therefore, the sanctions discussed for "unpermitted impacts" (Section 2a above) need to be applied. This scraped area should be restored promptly to the richness and cover of background native grass and forb species indigenous to this site at a 3:1 ratio, consistent with mitigation measures.

**c. Add to the permit's performance security fund by at least \$375,000 to ensure proper repair of unpermitted park damage.**

The ITP specifies that a "performance security fund" will be established to cover the expected costs of restoration needed after construction (ITP, Section 9). But because CDFW assumed that EBZS would comply with its permit requirements, there is no cost estimate or security (ITP, Sections 8.1 and 9) for repairing habitat damage resulting from permit violations. Therefore, the permit should be amended, as allowed in the ITP ("Amendment," p. 23), to require that a minimum of \$375,000 be added to the performance security fund to cover costs to ensure the site is made whole.

**If EBZS fails to complete this repair work by October 31, 2016**, or fails to meet its prescribed performance criteria for restoration within three years (October 31, 2019), the performance security funds would be used for a qualified, independent expert (appointed by CDFW) to oversee proper repairs and restoration of protected native grassland and Alameda striped racer habitat.

**3. Enforce the permit provisions for control of invasive weeds.**

As the City's agent for management of Knowland Park, EBZS unfortunately has demonstrated little regard for stewarding the park's natural resources. For example, Zoo exhibit debris and concrete was dumped years ago in a park swale leading to Arroyo Viejo Creek. In response to numerous

complaints, Dr. Joel Parrott and Nik Dehejia of EBZS sent a memo on June 3, 2011 to the Oakland City Council stating that the Zoo debris filling the park swale would be removed within 60 days. In 2016, it remains jutting out from the swale and draining into the creek (Figure 9). As this example illustrates, EBZS compliance with environmental permits will require active monitoring and enforcement, beyond EBZS written assurances.

**Figure 9.** Zoo exhibit debris dumped in Knowland Park was to be removed in 2011, but remains in a swale draining to Arroyo Viejo Creek to this day.



EBZS's biological consultants have stressed how this project will rescue this intact and ecologically thriving park from invasive weeds. But with the commencement of California Trail construction, invasive weeds have gone unattended and are proliferating. Permit requirements for invasive weed control must not be ignored at a time when Zoo construction activity has caused extensive soil disturbance that can accelerate the spread of these weeds.

The EBZS baseline invasive weed map is due to CDFW now (ITP, Section 7.11.2 "Invasive Species"). Please require EBZS to report on the status of meeting their invasive weed requirements (ITP, Section 6.4, "Monthly Compliance Report" and Section 6.5, "Annual Status Report"). If the invasive weeds are not eradicated in the months ahead, according to the permit, the permit should be suspended until its conditions for approval are met.

**4. Implement independent monitoring to ensure ongoing EBZS permit compliance.**

Impose monetary sanctions against EBZS' disregard for ITP provisions as a means to deter further permit violations. Use these sanctions to fund the needed independent site monitoring that will ensure that EBZS complies with their permit conditions *for the duration of this project*.

The Federal Endangered Species Act, a model for subsequent state laws, was designed to protect imperiled species from extinction as a "consequence of economic growth and development untempered by adequate concern and conservation." The point of CDFW's enforcement of the California Environmental Quality Act is to prevent significant, avoidable damage to the environment.

Please uphold this overarching aim by enforcing the terms of your permit and the basic measures intended to protect the rare plants and animal life of this wildland park. Any further unpermitted damage is unacceptable, especially for a project portrayed to teach about conserving native California.

We ask you to take corrective action promptly to reinforce the integrity of your permit and to command its due respect, as well as to restore the public trust that all CDFW permittees are held accountable to comply with their permit requirements.

We look forward to your response and we are happy to answer any questions.

Sincerely,

Karen Asbelle, Steering Committee Chair, Friends of Knowland Park  
 Barbara Leitner, President, East Bay Chapter, California Native Plant Society  
 Beth Wurzburg, Vice President, East Bay Chapter, California Native Plant Society  
 Jim Hanson, Conservation Chair, California Native Grasslands Association

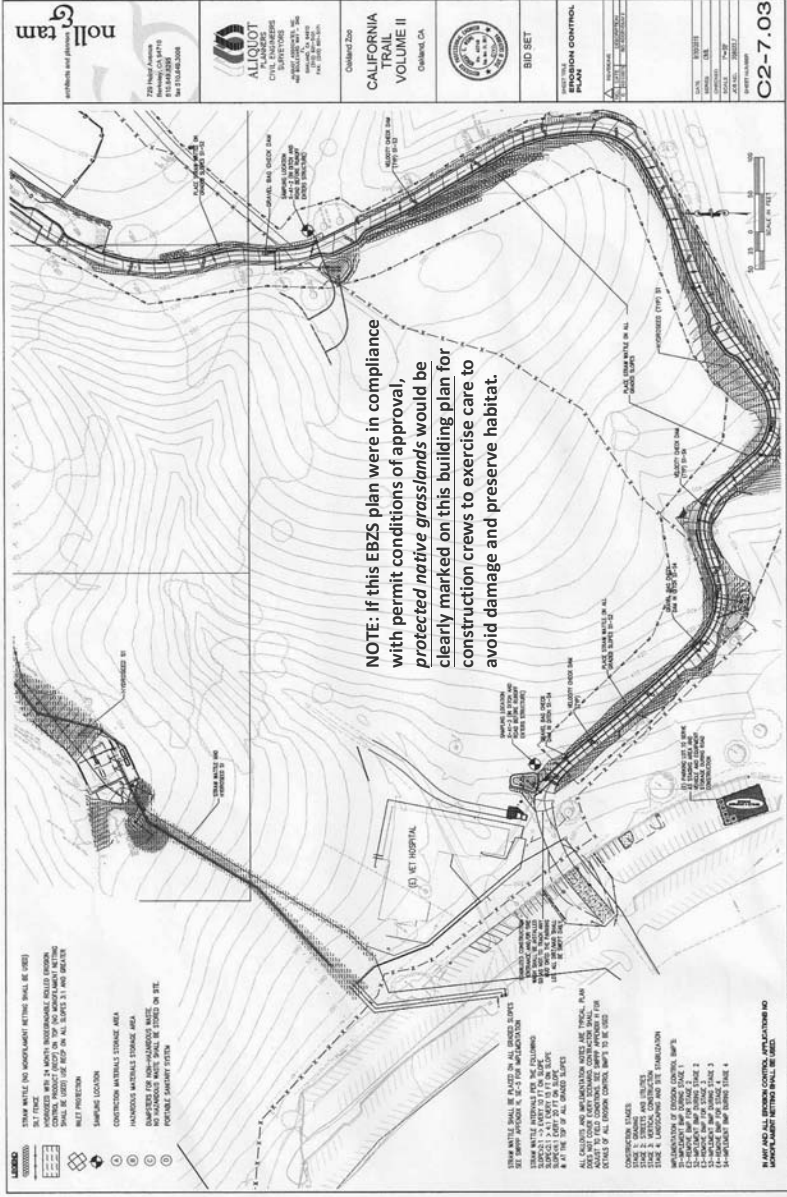
cc: Marcia Grefsrud, Environmental Scientist, Bay Delta Region, CDFW, [marcia.grefsrud@wildlife.ca.gov](mailto:marcia.grefsrud@wildlife.ca.gov)



A - ©Skimack 2016 B - ©Belinda Lo 2016 C - ©Ken-ichi 2016



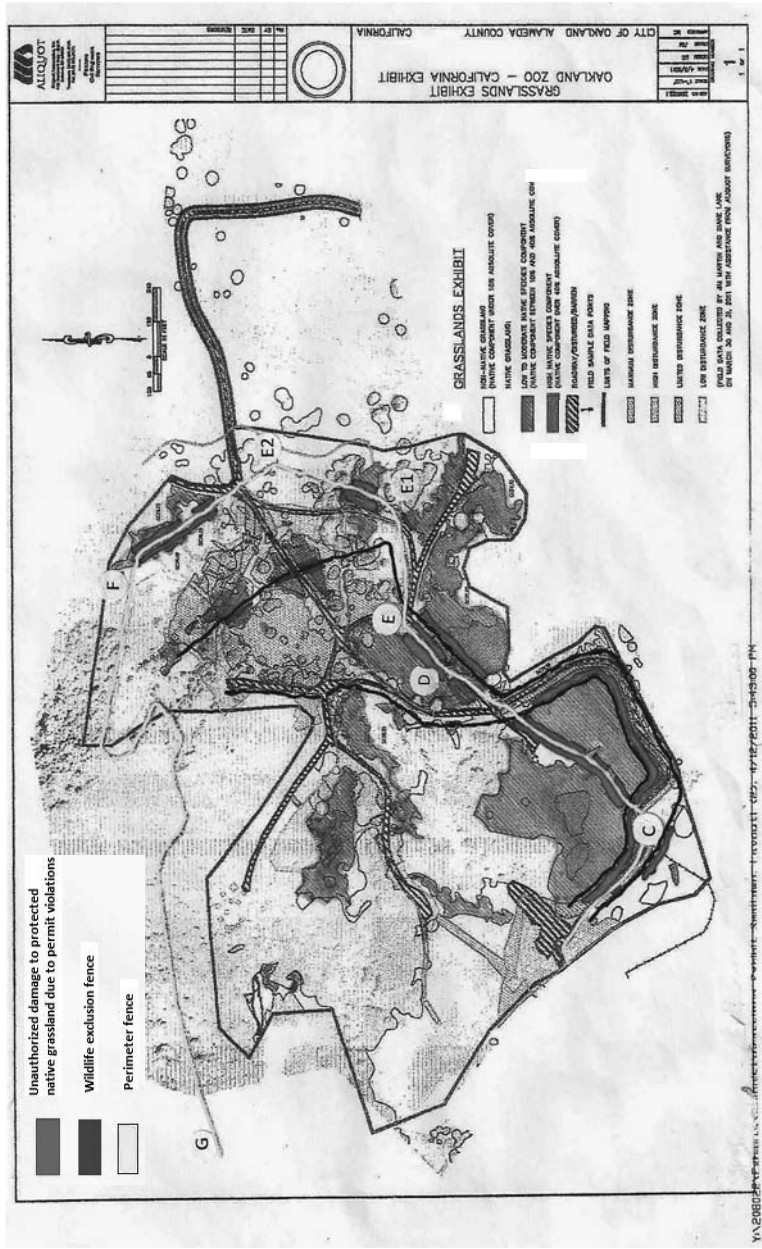
**Attachment 1B - Example of EBZS CA Trail building plan with no designation of protected native grasslands**  
 In direct violation of their regulatory permits, EBZS ignored requirement to map locations of "protected native grasslands" on all building plans.



**Attachment 1C: Layout of EBZS perimeter fence**  
 Lettered areas are taken from city building permits (#IGR 1500068 - #PZ15 000651)



**Attachment 1D: Overview of protected rare native grasslands/Alameda striped racer habitat damaged by EBZS construction in violation of environmental permits**



At least 1 acre of unpermitted damage is noted from project boundaries; acreage is clearly an underestimate and requires independent inventory. Damage further inside the project site is unknown. Lettered areas are taken from City building permits #GR1500068 – #PZ1500051 for perimeter fence.

**Attachment 2:**

“No-trench” wildlife exclusion fence – available and non-destructive alternative

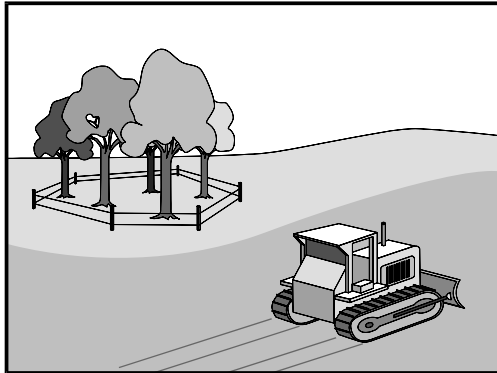


From manufacturer’s product description of a commercially-available wildlife exclusion fence:

“No-Trench Ground-Seal – An excellent option for areas that cannot be trenched such as: across creek areas with ephemeral flows, areas with no storm water permit, slopes, rough terrain, remote areas difficult to reach with trenching equipment, *areas where there is a preference not to disturb the soil.*”

“Partial list of approved configurations: Alameda striped racer (*Masticophis lateralis euryxanthus*), Arroyo toad (*Bufo microscaphus californicus*), Blunt-nosed leopard lizard (*Gambelia sila*), California red-legged frog (*Rana draytonii*), California tiger salamander (*Ambystoma californiense*), Coachella Valley fringe-toed lizard (*Uma inornata*), Desert tortoise (*Gopherus agassizii*), Foothill yellow-legged frog (*Rana boylei*), Giant garter snake (*Thamnophis gigas*), Giant kangaroo rat (*Dipodomys ingens*), Mojave ground squirrel (*Xerospermophilus mohavensis*), Northern cricket frog (*Acris crepitans*), Pacific tree frog (*Pseudacris regilla*), Riparian brush rabbit (*Sylvilagus bachmani riparius*), Salt marsh harvest mouse (*Reithrodontomys raviventris*), San Bernardino kangaroo rat (*Dipodomys merriami parvus*), San Francisco garter snake (*Thamnophis sirtalis tetrataenia*)...”

## Preservation Of Existing Vegetation EC-2



### Description and Purpose

Carefully planned preservation of existing vegetation minimizes the potential of removing or injuring existing trees, vines, shrubs, and grasses that protect soil from erosion.

### Suitable Applications

Preservation of existing vegetation is suitable for use on most projects. Large project sites often provide the greatest opportunity for use of this BMP. Suitable applications include the following:

- Areas within the site where no construction activity occurs, or occurs at a later date. This BMP is especially suitable to multi year projects where grading can be phased.
- Areas where natural vegetation exists and is designated for preservation. Such areas often include steep slopes, watercourse, and building sites in wooded areas.
- Areas where local, state, and federal government require preservation, such as vernal pools, wetlands, marshes, certain oak trees, etc. These areas are usually designated on the plans, or in the specifications, permits, or environmental documents.
- Where vegetation designated for ultimate removal can be temporarily preserved and be utilized for erosion control and sediment control.

### Limitations

- Requires forward planning by the owner/developer,

### Categories

EC	Erosion Control	<input checked="" type="checkbox"/>
SE	Sediment Control	
TC	Tracking Control	
WE	Wind Erosion Control	
NS	Non-Stormwater Management Control	
WM	Waste Management and Materials Pollution Control	

### Legend:

- Primary Objective
- Secondary Objective

### Targeted Constituents

Sediment	<input checked="" type="checkbox"/>
Nutrients	
Trash	
Metals	
Bacteria	
Oil and Grease	
Organics	

### Potential Alternatives

None



## Preservation Of Existing Vegetation EC-2

contractor, and design staff.

- Limited opportunities for use when project plans do not incorporate existing vegetation into the site design.
- For sites with diverse topography, it is often difficult and expensive to save existing trees while grading the site satisfactory for the planned development.

### Implementation

The best way to prevent erosion is to not disturb the land. In order to reduce the impacts of new development and redevelopment, projects may be designed to avoid disturbing land in sensitive areas of the site (e.g., natural watercourses, steep slopes), and to incorporate unique or desirable existing vegetation into the site's landscaping plan. Clearly marking and leaving a buffer area around these unique areas during construction will help to preserve these areas as well as take advantage of natural erosion prevention and sediment trapping.

Existing vegetation to be preserved on the site must be protected from mechanical and other injury while the land is being developed. The purpose of protecting existing vegetation is to ensure the survival of desirable vegetation for shade, beautification, and erosion control. Mature vegetation has extensive root systems that help to hold soil in place, thus reducing erosion. In addition, vegetation helps keep soil from drying rapidly and becoming susceptible to erosion. To effectively save existing vegetation, no disturbances of any kind should be allowed within a defined area around the vegetation. For trees, no construction activity should occur within the drip line of the tree.

### Timing

- Provide for preservation of existing vegetation prior to the commencement of clearing and grubbing operations or other soil disturbing activities in areas where no construction activity is planned or will occur at a later date.

### Design and Layout

- Mark areas to be preserved with temporary fencing. Include sufficient setback to protect roots.
  - Orange colored plastic mesh fencing works well.
  - Use appropriate fence posts and adequate post spacing and depth to completely support the fence in an upright position.
- Locate temporary roadways, stockpiles, and layout areas to avoid stands of trees, shrubs, and grass.
- Consider the impact of grade changes to existing vegetation and the root zone.
- Maintain existing irrigation systems where feasible. Temporary irrigation may be required.
- Instruct employees and subcontractors to honor protective devices. Prohibit heavy equipment, vehicular traffic, or storage of construction materials within the protected area.

## **Preservation Of Existing Vegetation EC-2**

### **Costs**

There is little cost associated with preserving existing vegetation if properly planned during the project design, and these costs may be offset by aesthetic benefits that enhance property values. During construction, the cost for preserving existing vegetation will likely be less than the cost of applying erosion and sediment controls to the disturbed area. Replacing vegetation inadvertently destroyed during construction can be extremely expensive, sometimes in excess of \$10,000 per tree.

### **Inspection and Maintenance**

During construction, the limits of disturbance should remain clearly marked at all times. Irrigation or maintenance of existing vegetation should be described in the landscaping plan. If damage to protected trees still occurs, maintenance guidelines described below should be followed:

- Verify that protective measures remain in place. Restore damaged protection measures immediately.
- Serious tree injuries shall be attended to by an arborist.
- Damage to the crown, trunk, or root system of a retained tree shall be repaired immediately.
- Trench as far from tree trunks as possible, usually outside of the tree drip line or canopy. Curve trenches around trees to avoid large roots or root concentrations. If roots are encountered, consider tunneling under them. When trenching or tunneling near or under trees to be retained, place tunnels at least 18 in. below the ground surface, and not below the tree center to minimize impact on the roots.
- Do not leave tree roots exposed to air. Cover exposed roots with soil as soon as possible. If soil covering is not practical, protect exposed roots with wet burlap or peat moss until the tunnel or trench is ready for backfill.
- Cleanly remove the ends of damaged roots with a smooth cut.
- Fill trenches and tunnels as soon as possible. Careful filling and tamping will eliminate air spaces in the soil, which can damage roots.
- If bark damage occurs, cut back all loosened bark into the undamaged area, with the cut tapered at the top and bottom and drainage provided at the base of the wood. Limit cutting the undamaged area as much as possible.
- Aerate soil that has been compacted over a tree's root zone by punching holes 12 in. deep with an iron bar, and moving the bar back and forth until the soil is loosened. Place holes 18 in. apart throughout the area of compacted soil under the tree crown.
- Fertilization
  - Fertilize stressed or damaged broadleaf trees to aid recovery.
  - Fertilize trees in the late fall or early spring.

## **Preservation Of Existing Vegetation EC-2**

- Apply fertilizer to the soil over the feeder roots and in accordance with label instructions, but never closer than 3 ft to the trunk. Increase the fertilized area by one-fourth of the crown area for conifers that have extended root systems.
- Retain protective measures until all other construction activity is complete to avoid damage during site cleanup and stabilization.

### **References**

County of Sacramento Tree Preservation Ordinance, September 1981.

Stormwater Quality Handbooks Construction Site Best Management Practices (BMPs) Manual, State of California Department of Transportation (Caltrans), November 2000.

Stormwater Management of the Puget Sound Basin, Technical Manual, Publication #91-75, Washington State Department of Ecology, February 1992.

Water Quality Management Plan for The Lake Tahoe Region, Volume II, Handbook of Management Practices, Tahoe Regional Planning Agency, November 1988.

INTRODUCTION

Significant  
Plants of Alameda and Contra  
Costa Counties. 4th Edition  
Diana Lake  
201

The botanical wealth of the East Bay is rarely realized or appreciated. More plant communities come together in Alameda and Contra Costa counties than almost anywhere else in the state. Great Valley vegetation meets Coastal, and moist northern communities meet dry southern ones. Islands of Sierran and desert vegetation occur here as well as serpentine outcrops, vernal pools, dune fields, and alkaline communities. Salt marshes fringe San Francisco Bay, freshwater marshes border the Delta, and brackish marshes lie in between. Fifty-five plant species reach their northern range limit here and 19 reach their southern limit.

Of the estimated 1500 plant taxa occurring in the two counties, 135 are currently listed as rare or endangered statewide by the U.S. Fish and Wildlife Service, the California Department of Fish and Game, or the state level of the California Native Plant Society (CNPS), and are thus protected by the California Environmental Quality Act (CEQA).

But many more plant species also lead a precarious existence here. In the course of its field studies, the East Bay Chapter of the California Native Plant Society has found 608 additional species that would meet the standards for rare and endangered status if only their populations in these two counties were considered. Many of these plants occur in very limited or threatened habitats and their numbers are in decline. Of these 608 species, 313 have only one or two currently known locations in Alameda and Contra Costa Counties (ranked as A1 in the East Bay); 231 occur in less than five places in the two counties or are otherwise endangered (A2), and 64 are only known from the area historically and are presumed to have been extirpated here in the last 100 years (A1x).

These 608 locally rare, or unusual, plant species (ranked A1, A2 or A1x in this report) are protected by CEQA in sections 15380 and 15125(a) which address species of local concern and place special emphasis on environmental resources that are rare or unique to a region. Thus they must be considered in local land planning and management issues along with the 135 statewide rare plants referred to above. Unfortunately, they are often overlooked or ignored.

An additional 191 plants are on a High-Priority Watch List and are ranked B, generally occurring in only six to nine regions of the two counties. While they are not currently rare or threatened locally and are not protected by CEQA, they should be closely watched since they could become rare, threatened or endangered if their habitats continue to disappear or decline or other detrimental environmental conditions continue.

A Second-Priority Watch List of 137 C-ranked plants is provided in Appendix C but they are not included in the body of the report. Although still relatively common and widespread in the two-county area (occurring in 10 to 15 regions), they should be monitored since they could also become less common if certain conditions persist.

Because the flora of this area is unique, we must recognize the importance of protecting and preserving these native plant populations and remember that the loss of any species alters and damages the surrounding ecosystem. At the same time, we must seek a better understanding of these plants and how they depend upon and contribute to the environment. This report of *Rare, Unusual and Significant Plants of Alameda and Contra Costa Counties* is presented in the hope that it will serve as a valuable tool in achieving these goals.

METHODOLOGY

In compiling this list, many Bay Area botanists were contacted for their views, and plant lists were reviewed for many East Bay locations. Extensive field studies as well as literature and herbaria search were conducted. An initial list of 865 candidate species was compiled in 1991 and reviewed by 35 botanists familiar with East Bay flora. Their comments, additions, and changes were reviewed and incorporated. Further field research, interviews, and literature and herbaria searches were then conducted. The resulting list consisted of 611 species, and the report was first issued on March 1, 1999.

Research has continued over the years and the current list consists of 958 species, including 135 statewide rare plants, 632 A-ranked locally rare plants, and 191 B-ranked plants. In addition, a Watch list of 137 C-ranked species is included as Appendix C.

A ranking system was devised based on the number of current locations in Alameda and Contra Costa counties, with A1 indicating plants with only two or less locations here; A2 indicating three to five locations here; and B indicating plants with six to nine locations here. A Watch list with a rank of C was also devised for plants not currently rare, threatened or endangered in the two counties, but with potential to become so if certain trends and practices continue, such as over-development, water diversion, excessive grazing practices, weed and insect invasion, etc.

Other criteria besides number of occurrences were also looked at and a few plants that had more than five locations here but met other criteria were included in the A2 rank, and some plants with more than nine locations here were included in the B rank. Conversely some plants that occur in only three to five places but had large or multiple populations there were moved to a B rank, and some found in only six to nine areas but with large or multiple populations were moved to the C rank. The criteria that qualify these plants for the higher or lower ranks are indicated in the "Comments" column in the body of the report.

Research has continued over the years with more field surveys, herbarium and literature searches, and interviews with area botanists. Herbarium vouchers have been checked at several Bay Area herbaria for all A-ranked (\*A1, \*A1x, A1, A1x, A1?, \*A2, and A2) species and most B-ranked species.

Many people have provided new information and comments, and reader response to both the project and the report itself has been excellent. As a result, new locations have been found for some plant species, while others have been found to be more unusual or threatened than originally thought.



Attachment 4: California Native Plant Society, Lake Inventory, 2011 (p. 3 of 11)

AIM OF REPORT

It is hoped that this report of *Rare, Unusual and Significant Plants of Alameda and Contra Costa Counties* will prove helpful to botanists, planners, land managers, consultants, students and others working with the vegetation of Alameda and Contra Costa counties, and that it will serve to clarify and identify the valuable resources found in this area.

This report also aims to help the reader become aware of the sensitivity and significance of the plants listed in this report, so that when they are encountered in the field they will be treated accordingly.

The high number of plant species appearing in this report and the range of threats facing them in the two counties indicates some of the problems posed by modern society for the natural resources of this area. It is important to recognize the value of these plant populations and how they affect their surrounding environment - their importance to not only the plants that occur there, but also to the wildlife and humans who depend on that environment. A complex inter-dependence exists between man and nature, and the loss or lessening of any of these rare or unusual plant species affects the health of the human, wildlife, and plant environments in which they occur.

The importance of the survival of these plant species must be recognized, and a way must be found for people to co-exist with the natural resources of the area without one severely endangering the other. Steps must be taken to protect these plant populations, and studies must be conducted to better understand the needs of these plants, and what must be done to assure their continued health and proliferation.

To achieve this delicate balance between man and environment, it is essential to learn more about the complex requirements of the various plants in that environment. It is hoped that this report will inspire and help provide areas of study and research for students and researchers, as well as provide important plant distribution information for planners, developers, and land managers.

The list should by no means be considered as a final product and will continue to change as more data become available. The continued accuracy and usefulness of this report depends on the input and cooperation of as many people and sources as possible. All comments, additional information, and suggestions are welcome. The East Bay Chapter of the California Native Plant Society is dedicated to keeping this list as up-to-date and accurate as possible, and information should be addressed to Dianne Lake, 1050 Bayview Farm Rd., #121, Pinole, CA 94564 (Phone: 510-741-8066; Email: [diannelake@yahoo.com](mailto:diannelake@yahoo.com)).

I would like to thank all those who have already commented on and provided information for the report.

Attachment 4: California Native Plant Society, Lake Inventory, 2011 (p. 4 of 11)

PLANTS INCLUDED

"Rare, Unusual and Significant Plants" refers to plant species that are rare, threatened, or endangered in Alameda and Contra Costa Counties, as well as those that meet that criteria statewide. (See discussion of "Rare Plants" and "Unusual Plants" below.)

Only terrestrial, vascular plants are included. An arbitrary decision was made to not include aquatic or non-vascular plants in the interest of keeping the size of the report manageable.

This should in no way be interpreted as an indication that aquatic and non-vascular plants are less important. If anything, it should indicate the need for further study of these plants, and of the importance of compiling similar data for them. Aquatic and non-vascular plants have a very important place in the environment and it is imperative that we increase our knowledge of them - their requirements for survival, their interaction with the local and global environment, and their distribution in our area as well as worldwide. This situation has been realized over the last several years and many efforts are now underway to compile and distribute this important data and to make the general public aware of their importance and need for protection.

Rare Plants

Statewide listed rare plants are indicated by an asterisk preceding their rank, and appear in upper case type.

"Statewide listed rare plants" refers to those species listed as rare, threatened or endangered, or as candidates for such listing, by the U.S. Fish and Wildlife Service, California Dept. of Fish and Game, or the state level of the California Native Plant Society. As of January, 2010, 135 statewide rare plant species are listed as occurring in Alameda and Contra Costa counties either currently or historically.

More detailed information can be found in the sixth edition of the CNPS *Inventory of Rare and Endangered Plants of California*, or the on-line seventh edition at [CNPS.org/inventory](http://CNPS.org/inventory).

Complete information on rare plants can be obtained from the California Natural Diversity Data Base of the California Dept. of Fish and Game, Sacramento.

Unusual Plants

Unusual plants are indicated by A1, A1x, A1?, A2, or B in the Rank column, with no asterisk preceding the rank.

"Unusual plants" refers to plants that are rare, threatened or endangered in Alameda and Contra Costa counties but not necessarily in the rest of the state, or plants that are on a High-Priority Watch List (B List). This status has been determined through extensive research carried out by the East Bay Chapter of the California Native Plant Society. These ranks and the criteria used to determine them are discussed under "Ranks" below.

Attachment 4: California Native Plant Society, Lake Inventory, 2011 (p. 5 of 11)

NOMENCLATURE

Most species names used in this report are in agreement with those in *the Jepson Manual: Higher Plants of California* by James Hickman (1993) or the *Online Interchange For California Floristics* ([ucjeps.berkeley.edu/interchange](http://ucjeps.berkeley.edu/interchange)) which contains updated taxonomy and treatments being compiled for the second edition of the Jepson Manual.

In a few cases, however, the plant names differ, as follows:

Three species of clovers that are included within *Trifolium barbigerum* var. *andrewsii* or *T. fucatum* in the Jepson Manual are listed in this report as separate species: *T. flavulum*, *T. gambelli*, and *T. lilacinum*.

In addition, recent studies have determined that plants in the East Bay previously identified as *Angelica tomentosa* are actually *A. californica*.

RANKS

Ranks are based on the number of botanical regions a species currently occurs in, rather than the number of specific sites. This gives a much more accurate indication of the geographical distribution of a plant species. There may be several specific sites for a species, but if they are all within a few miles of each other, the species is actually much rarer and more endangered than one with the same number of specific sites but spread over a wider range. (See discussion of "Regions" in "Locations" sections on page In-7)

The ranks are as follows:

- \*A (114 spp.): Species in Alameda and Contra Costa counties listed as rare, threatened or endangered statewide by federal or state agencies or by the state CNPS.  
Protected by CEQA  
(Includes 59 \*A1, 18 \*A1x, and 37 \*A2 species)
- A1 (370 spp.): Species known from 2 or less botanical regions in Alameda and Contra Costa Counties, either currently or historically. Protected by CEQA  
(Includes 59 \*A1 and 311 A1 species)
- A1x (89 spp.): Species previously known from Alameda or Contra Costa Counties, but now believed to have been extirpated, and no longer occurring here.  
Protected by CEQA  
(Includes 18 \*A1x and 71 A1x species)
- A1? (24 spp.): Species possibly occurring in Alameda or Contra Costa counties but there are questions about their identification or location
- A2 (243 spp.): Species currently known from 3 to 5 regions in the two counties, or, if more, meeting other important criteria such as small populations, stressed or declining populations, small geographical range, limited or threatened habitat, etc.  
Protected by CEQA  
(Includes 37 \*A2 and 206 A2 species)

Attachment 4: California Native Plant Society, Lake Inventory, 2011 (p. 6 of 11)

- B (164 spp.): A High-Priority Watch List: Species currently known from 6 to 9 regions in the two counties, or, if more, meeting other important criteria as described above for A2. (Not protected by CEQA)
- C (137 spp.): A Second-Priority Watch List: Species currently known from 10 to 15 regions in the two counties, but potentially threatened if certain conditions persist such as over-development, water diversions, excessive grazing, weed or insect invasions etc. (Listed only in Appendix C and not included in main body of report).

Several criteria have been used to determine which plants qualify for the Rare, Unusual and Significant Plants list. Statewide listing and two or fewer occurrences in Alameda and Contra Costa counties were the first criteria used. But it was discovered that many plants not falling into these two categories were still threatened or endangered here. Several other criteria were therefore looked at as follows:

- Disjunct Populations
- Declining Populations
- Fire-following Plants
- Limited or Threatened Habitats
- Narrow Range in Alameda and Contra Costa Counties
- Range Limits
- Small Populations
- Small Geographical Range
- Stress from weed invasions, disease, insects, drought, etc.

The rank of a species is based only on current populations (1975 or later). Historical, planted, and unconfirmed sites (indicated by parentheses) are not considered since it is not known if the species is currently there, or the population does not occur there naturally.

In a few instances a plant species has more occurrences than its rank indicates, but poor field conditions such as very small or declining populations, small geographical range, limited or threatened habitats, etc. give it the higher rank. In a few other instances a species occurs in fewer places than its rank indicates but large or multiple populations qualify it for a lower rank. The reason for the different rank is explained in the "Comments" column in the report.

LOCATIONS

The current location system, developed for the fifth edition in 1999, consists of 40 botanical regions, and specific sites within those regions. The locations are listed alphabetically by region, with specific sites following. Ranks are determined by the number of regions a species is currently known to occur in, rather than the number of specific sites.

Historical, introduced, and unconfirmed populations are also included in parentheses, but have not been considered in the determination of ranks since it is not known whether or not the populations still exist, or the populations do not occur at the site naturally.

A list of the 40 regions and the specific sites in each can be found starting on page L-1. An alphabetical list of the specific sites occurs at the end of the report.

Attachment 4: California Native Plant Society, Lake Inventory, 2011 (p. 7 of 11)

A map of the regions appears on p. M-1, and a map of many of the specific sites and the regions in which they occur appears on page M-2.

#### Regions

The regional location system was developed to provide a more accurate picture of the actual distribution of species in the two counties than had been available in the early editions of the report.

Because some areas have been more broadly explored botanically than others, the listing of only specific locations in early editions of this report did not always give an accurate indication of a species' real distribution. For example, the Berkeley Hills have been studied extensively over the years because of their proximity to the University of California at Berkeley, while more outlying areas such as Brentwood and Byron, for example, have not been visited as often. Thus, when ranks were based only on specific sites, as in the early editions of this report, plant species in well-explored areas appeared to be more common than they actually were.

To demonstrate, *Asarum caudatum* would be ranked at the C level using the specific locations system because it currently occurs at 13 specific sites. However, all of these sites are within a few miles of each other and are in similar habitats. Thus, this species is not as common or widespread in the two counties as a C rank would indicate. It actually only occurs in a very small geographical area of the two counties and only in a particular kind of habitat. Using the region system, these 13 specific sites are contained in only four regions, thus giving this plant an A2 rank which is much more indicative of its actual field condition and distribution in the East Bay.

The regions system is based on the eight major regions or sub-divisions of the East Bay determined by Dr. Barbara Ertter in her *Annotated Checklist of the East Bay Flora* (1997). These eight regions were examined, comparing botanical, geological, and geographical characters such as vegetation types, plant communities, habitats, individual plant species occurrences, soil types, bedrock strata, and topography. These studies and comparisons resulted in the development of the 40 botanical regions.

#### Specific Sites

The number of specific sites has increased over the years as more areas have been explored. Some codes have been divided or expanded, thus giving a more accurate picture of distribution and the actual field conditions of each species.

The list of 40 botanical regions and the specific sites within those regions can be found starting on page L-1. An alphabetical list of specific sites is provided at the end of the report in the Locations Index.

#### Historical Sites

Populations have been divided into current and historical occurrences with 1975 as the dividing line. This also gives a more accurate picture of the current field conditions of a species and allows for comparisons to past conditions, and the determination of which species may be declining.

Historical populations are included in parentheses with the date of the last known sighting, and are not considered when determining rank because ranks are based only on current populations.

Many plants have not been seen since 1975 or before and are presumed to have been extirpated. These species now have a rank of A1x. A list of these species is provided in Appendix A along with their habitats and where they occurred. The rediscovery of any of these species would be very significant, and the reader is requested to contact the author at (510) 741-8066 or [djannelake@yahoo.com](mailto:djannelake@yahoo.com) if they find any of these extirpated species.

Attachment 4: California Native Plant Society, Lake Inventory, 2011 (p. 8 of 11)

The dividing year between current and historical was 1950 for previous editions, but has now been moved up to 1975. While 1950 was an appropriate division in 1992 when the report first came out, many of those records are now over 60 years old and can hardly be considered "current". Thus 1975 is no more accurate indication of currency.

#### Unconfirmed Identifications and Sites

"ID?": The identification of some populations are questionable and have not been confirmed. These sites are included in parentheses and indicated by "ID?". They are not considered in the determination of ranks because rank is based only on current populations.

Over the years many of these populations have been visited and identified. Thus the number of locations with this designation has declined substantially with each new edition.

"Loc?": The locations for some populations are questionable. These species have been reported in an area but have not yet been confirmed there. These sites are also included in parentheses and are followed by "Loc?". They are not considered when determining the rank of a plant species.

Many of these sites have also been visited over the years and several have been found, thus reducing the number of such designations.

#### Planted Sites

Some populations have been introduced as landscaping or restoration projects. These populations are included in parentheses. Since these are not natural sites, they have not been considered in the determination of ranks.

### HABITATS

Habitats are listed to help clarify and identify where plants may occur and where they should be looked for. With the increased interest and concern in protecting plant communities and areas, habitat information is an essential tool in determining which areas need protection. A list of habitats and their codes is provided on page In-11.

Habitat requirements were determined by studying habitat and community information in *The Jepson Manual: Vascular Plants of California* by James Hickman (ed.) (1993), *A California Flora and Supplement* by Munz and Keck (1973), *A Manual of California Vegetation* by John O. Sawyer and Todd Keeler-Wolf, 1995, *A Preliminary Guide to the Terrestrial Plant Communities of California* by Robert F. Holland (1986) and the sixth edition of the CNPS *Inventory of Rare and Endangered Vascular Plants of California* by David Tibor (2001), as well as discussions with several bay area botanists.

Many plants qualify for this report at least partially because they occur only in habitats that are limited and/or threatened in Alameda and Contra Costa Counties: alkali areas, perennial grassland, redwood forest, rocky or talus areas, sand or sandstone soils (including coastal bluff and coastal strand), serpentine or serpentine-derived soils, and wetlands (including brackish, freshwater, and salt marshes, riparian areas, vernal pools and miscellaneous wetlands).

Attachment 4: California Native Plant Society, Lake Inventory, 2011 (p. 9 of 11)

from Dianne Lake  
 Rare and Unusual Plants of Knowland Park (Current and Historical)  
 As Of January 2011  
 (Statewide Rare Plants Are In Upper Case)

East Bay Rarity Rank	Species	Common Name	Habitat
A2	<i>Brodiaea terrestris</i> ssp. <i>terrestris</i>	dwarf brodiaea	Grassland; Woodland; Misc. Wetlands
*A2	CALOCHORTUS UMBELLATUS	Oakland star-tulip	Chaparral; Scrub; Woodland
A1	<i>Carex dudleyi</i>	Dudley's sedge	Misc. Wetlands
A2	<i>Carex multicosata</i>	many-ribbed sedge	Misc. habitats
A2	<i>Castilleja subinclusa</i> ssp. <i>franciscana</i>	Franciscan Indian paintbrush	Chaparral; Scrub
A2	<i>Corallorhiza maculata</i> var. <i>maculata</i> (forma <i>immaculata</i> is more common in East Bay)	spotted coralroot	Forest; Woodland
A2	<i>Cryptantha torreyana</i>	Torrey's cryptantha	Dry Open Slopes; Forest
A2	<i>Deinandra corymbosa</i> ssp. <i>corymbosa</i> (formerly <i>Hemizonia corymbosa</i> )	coast tarweed	Coastal Bluff; Grassland
A2	<i>Juncus phaeocephalus</i> var. <i>unknown</i>	brown-headed rush	Misc. Wetlands
*A1	LEPTOSIPHON ACICULARIS (formerly LINANTHUS A.)	bristly linanthus	Chaparral; Grassland; Woodland
*A2	MONARDELLA VILLOSA SSP. GLOBOSA (ssp. <i>villosa</i> is more common)	robust monardella	Chaparral; Woodland
A2	<i>Sanicula laciniata</i>	coast sanicle	Chaparral; Scrub; Woodland
*A2	STREPTANTHUS ALBIDUS SSP. PERAMOENUS	most beautiful jewel-flower	Chaparral; Dry Open Slopes; Grassland; Serpentine

**Explanation of Ranks**

**\*A1 or \*A2:** Species in Alameda and Contra Costa counties listed as rare, threatened or endangered statewide by federal or state agencies or by the state level of CNPS.

**A1x:** Species previously known from Alameda or Contra Costa Counties, but now presumed extirpated here.

**A1:** Species currently known from 2 or less regions in Alameda and Contra Costa Counties.

**A2:** Species currently known from 3 to 5 regions in the two counties, or, if more, meeting other important criteria such as small populations, stressed or declining populations, small geographical range, limited or threatened habitat, etc.

**A1?:** Species with taxonomic or distribution problems that make it unclear if they actually occur here.

**B:** High-Priority Watch List: Plants occurring in 6 to 9 regions here or otherwise limited or threatened.

**C:** Second-Priority Watch List: Plants occurring in 10 to 15 regions here, but have potential threats.

Attachment 4: California Native Plant Society, Lake Inventory, 2011 (p. 10 of 11)

from Dianne Lake  
 B-Ranked Unusual Plants of Knowland Park (Current and Historical)  
 As Of January 2011

East Bay Rarity Rank	Species	Common Name	Habitat
B	<i>Antirrhinum vexillocalyculatum</i> ssp. <i>vexillocalyculatum</i>	wiry snapdragon	Rock, Tallus or Scree; Sand or Sandstone areas; Serpentine
B	<i>Calamagrostis rubescens</i>	pine grass	Woodlands
B	<i>Festuca rubra</i>	red fescue	Coastal Bluff; Grassland; Sand or Sandstone
B	<i>Garrya elliptica</i>	silk tassel bush	Coastal Bluff; Chaparral; Sand or Sandstone; Woodland
B	<i>Helianthemum scoparium</i>	peak rush-rose	Chaparral; Dry Open Slopes; Rock, Tallus or Scree; Sand or Sandstone
B	<i>Hordeum jubatum</i>	foxtail barley	Misc. habitats
B	<i>Mentha arvensis</i>	marsh mint	Riparian areas; Misc. Wetlands
B	<i>Ribes divaricatum</i> var. <i>pubiflorum</i>	straggly gooseberry	Coastal Bluff; Riparian; Scrub
B	<i>Rumex salicifolius</i> var. <i>unknown</i>	willow dock	Riparian areas; Misc. Wetlands
B	<i>Sequoia sempervirens</i>	coast redwood	Redwood Forest
B	<i>Sidalcea malviflora</i> ssp. <i>malviflora</i> (ssp. <i>laciniata</i> is more common)	checkerbloom	Grassland
B	<i>Silene laciniata</i> ssp. <i>californica</i> (formerly <i>Silene c.</i> )	California Indian pink	Chaparral; Forest; Woodland
B	<i>Vaccinium ovatum</i>	California huckleberry	Forest; Redwood Forest
B	<i>Vulpia octoflora</i> var. <i>unknown</i>	slender fescue	Chaparral; Dry Open Slopes; Dry Washes; Sand or Sandstone

**Explanation of Ranks**

**\*A1 or \*A2:** Species in Alameda and Contra Costa counties listed as rare, threatened or endangered statewide by federal or state agencies or by the state level of CNPS.

**A1x:** Species previously known from Alameda or Contra Costa Counties, but now presumed extirpated here.

**A1:** Species currently known from 2 or less regions in Alameda and Contra Costa Counties.

**A2:** Species currently known from 3 to 5 regions in the two counties, or, if more, meeting other important criteria such as small populations, stressed or declining populations, small geographical range, limited or threatened habitat, etc.

**A1?:** Species with taxonomic or distribution problems that make it unclear if they actually occur here.

**B:** High-Priority Watch List: Plants occurring in 6 to 9 regions here or otherwise limited or threatened.

**C:** Second-Priority Watch List: Plants occurring in 10 to 15 regions here, but have potential threats.

Attachment 4: California Native Plant Society, Lake Inventory, 2011 (p. 11 of 11)

C-Ranked Unusual Plants of Knowland Park (Current and Historical)  
As Of January 2011

East Bay

Rarity

Rank	Species	Common Name	Habitat
C	<i>Acaena pinnatifida</i> var. <i>californica</i>	California acaena	Coastal Bluff; Rock, Scree or Tallus; Scrub; Sand or Sandstone
C	<i>Arctostaphylos tomentosa</i> ssp. <i>crustacea</i>	brittleleaf manzanita	Chaparral; Sand or Sandstone
C	<i>Calochortus luteus</i>	yellow mariposa lily	Forest; Grassland; Woodland
C	<i>Camissonia ovata</i>	sun cup	Coastal Bluff; Grassland
C	<i>Clematis ligusticifolia</i>	virgin's bower	Riparian
C	<i>Danthonia californica</i> var. <i>californica</i>	California oatgrass	Grassland
C	<i>Hemizonia congesta</i> ssp. <i>lutescens</i> (formerly included in ssp. <i>congesta</i> in Jepson Manual)	hayfield tarweed	Grassland; Serpentine
C	<i>Lilaea scilloides</i>	flowering quillwort	Misc. Wetlands
C	<i>Navarretia mellita</i>	honey-scented navarretia	Chaparral; Gravel; Sand or Sandstone
C	<i>Prosartes hookeri</i> (formerly <i>Disporum h.</i> )	fairy bells	Woodland
C	<i>Rhamnus crocea</i>	spiny redberry	Chaparral; Scrub; Woodland
C	<i>Scutellaria tuberosa</i>	Dannie's skullcap	Burns; Chaparral; Woodland
C	<i>Tauschia hartwegii</i>	Hartweg's tauschia	Chaparral; Woodland
C	<i>Viola pedunculata</i>	Johnny-jump-up	Chaparral; Grassland; Woodland
C	<i>Vulpia microstachys</i> var. <i>ciliata</i> (var. <i>pauciflora</i> is more common)	Eastwood's fescue	Forest; Sand or Sandstone
C	<i>Wyethia glabra</i> ( <i>W. helenioides</i> is more common)	mule ears	Scrub; Woodland
C	<i>Yabea microcarpa</i>	California hedge parsley	Misc. habitats

**Explanation of Ranks**

**\*A1 or \*A2:** Species in Alameda and Contra Costa counties listed as rare, threatened or endangered statewide by federal or state agencies or by the state level of CNPS.

**A1x:** Species previously known from Alameda or Contra Costa Counties, but now presumed extirpated here.

**A1:** Species currently known from 2 or less regions in Alameda and Contra Costa Counties.

**A2:** Species currently known from 3 to 5 regions in the two counties, or, if more, meeting other important criteria such as small populations, stressed or declining populations, small geographical range, limited or threatened habitat, etc.

**A1?:** Species with taxonomic or distribution problems that make it unclear if they actually occur here.

**B:** High-Priority Watch List: Plants occurring in 6 to 9 regions here or otherwise limited or threatened.

**C:** Second-Priority Watch List: Plants occurring in 10 to 15 regions here, but have potential threats.

# WILEY

**Society for Conservation Biology**

Park Management of Exotic Plant Species: Problems and Issues

Author(s): Walter E. Westman

Source: *Conservation Biology*, Vol. 4, No. 3 (Sep., 1990), pp. 251-260

Published by: Wiley for Society for Conservation Biology

Stable URL: <http://www.jstor.org/stable/2385782>

Accessed: 03-10-2016 20:32 UTC

JSTOR is a not-for-profit service that helps scholars, researchers, and students discover, use, and build upon a wide range of content in a trusted digital archive. We use information technology and tools to increase productivity and facilitate new forms of scholarship. For more information about JSTOR, please contact support@jstor.org.

Your use of the JSTOR archive indicates your acceptance of the Terms & Conditions of Use, available at

<http://about.jstor.org/terms>



Society for Conservation Biology, Wiley are collaborating with JSTOR to digitize, preserve and extend access to *Conservation Biology*

# Park Management of Exotic Plant Species: Problems and Issues

WALTER E. WESTMAN

Applied Science Division  
Lawrence Berkeley Laboratory, Building 90-3125  
1 Cyclotron Road  
Berkeley, CA 94720, U.S.A.

**Abstract:** Vegetation management policies in public parks in the United States call for the removal of exotic species to the extent feasible. The underlying goal is to preserve samples of wilderness by restoring plant communities to the "natural state" that existed prior to extensive human influence. With limited budgets, park managers are necessarily selective in targeting exotic species for control. If the focus is on the more readily controlled species, however, park landscapes may gradually become populated by more resistant exotics. Further, because plants exhibit some redundancy in ecosystem function, exotic plant species can substitute in part for natives in performing a range of ecosystem functions, including wildlife support and soil binding. Consequently the removal of exotics can result in significant perturbations to certain ecosystem functions during the period of transition to native cover. The individualistic paradigm of plant distribution implies that the impact of exotic plant species on invaded communities will vary. Choosing which species to remove requires careful evaluation of the impact of the removal on ecosystem structure and function. The effective balancing of park management goals for wilderness maintenance and recreational use requires clearer recognition of the adaptive response of ecosystems to invasion and a rethinking of the bases for prioritizing which species are to be removed.

## Introduction

Current policies for managing exotic plant species in most park reserves in the United States reflect the influence of the report produced by A. Starker Leopold and

**Resumen:** Las políticas de manejo de la vegetación en parques públicos de los Estados Unidos hacen un llamado para la eliminación de las especies exóticas hasta donde sea posible. La meta fundamental es preservar muestras de áreas silvestres, al hacer restablecimiento de las comunidades de plantas al "estado original" que tenían antes de la extensa influencia humana. Con presupuestos limitados, los manejadores de parques son por necesidad, selectivos al escoger las especies exóticas que se van a controlar. Como quiera que sea, el enfoque es en las especies que se pueden controlar más fácilmente, los paisajes en los parques podrían irse poblando gradualmente de especies exóticas más resistentes. Además, debido a que las plantas exhiben algo de redundancia en la función del ecosistema, las especies de plantas exóticas pueden ser substituidas en parte por nativas al realizar una variedad de funciones en el ecosistema, incluyendo sustento para la vida silvestre y fijación de suelos. Consecuentemente, la eliminación de especies exóticas puede resultar en perturbaciones significativas de ciertas funciones del ecosistema durante el período de transición hacia la cubierta nativa. El paradigma individualista de la distribución de plantas implica que el impacto de las especies de plantas exóticas en comunidades invadidas variará. El escoger las especies que se van a eliminar requiere de una cuidadosa evaluación del impacto de la eliminación sobre la estructura y función del ecosistema. El balance efectivo de las metas del manejo de los parques para el mantenimiento de la naturalidad y el uso recreativo requiere de un conocimiento más claro de la respuesta adaptativa de los ecosistemas hacia la invasión y una reconsideración de las bases para priorizar cuáles especies se van a eliminar.

colleagues (1963) for the National Park Service. The Leopold Committee suggested that the goal for biotic management within the National Park Service be to maintain or recreate biotic associations "as nearly as possible in the condition that prevailed when the area

251

Conservation Biology  
Volume 4, No. 3, September 1990

was first visited by white man [sic]. A national park should represent a vignette of primitive America" (Leopold et al. 1963, p. 3). The committee acknowledged the difficulty of reaching such a goal in full, but encouraged approaching it by achieving "a reasonable illusion of primitive America" (p. 4).

As such language became translated into public policy in federal and state park systems throughout the country, the goals of exotic species management were framed in more absolutist terms. In California, for example, all state parks were to replace exotic plant species capable of naturalizing in California with native or "noninvading" species (California Department of Parks and Recreation 1979). This subtle shift in policy language has resulted in a major dilemma for park managers. Policy directives call for the elimination of all exotic species, yet effective extirpation of even one widespread and abundant plant species from park boundaries can rapidly exceed available funds. No guidelines for prioritizing effort are to be found in these general policies. Further, once an established plant species is removed, managers must control erosion and other potential damage resulting from the removal, and promote restoration of native plant species. Often experience with necessary restorative techniques is inadequate (Cairns 1989; cf. Jordan et al. 1988). Meanwhile, wildlife species that came to use the exotic vegetation for food and shelter face the loss of this habitat without replacement for an extended period.

In the absence of guidelines for prioritization and the accompanying ecological knowledge to implement them, park managers have had to resort to more pragmatic and less scientific criteria for implementing policy. Often the easiest plant species to control are given the most attention, regardless of the relative ecological damage they pose.

In this article, I review key policy and science issues related to exotic plant management. While biologists have come to recognize the continually varying nature of plant assemblages, public policy reflects an older, more rigid view of community organization in which each invader was seen as representing an equal threat to host community integrity. I examine some implications of implementing an unprioritized system of exotic species removal and suggest criteria for establishing priorities. The challenge to managers is to prioritize efforts at exotic species control with sufficient ecological understanding to achieve overall goals for park management, including wilderness preservation. I illustrate some of the difficulties in meeting this challenge using the example of *Eucalyptus* removal from California parks.

## The State of Public Policy

As the term is used widely in park practice, an "exotic" species is one that is newly established at a significant

distance from its former geographic range. In park practice, the term includes both significant range extensions by species native to another part of the state or region, and introductions of species from distant regions or continents (whether by natural dispersal or human agency).

The implicit goal of exotic species removal would appear to be to purge unnatural and destabilizing elements from coevolved biotic communities. As this goal is examined more closely, however, its elements fall open to question. How unnatural is the invasion process? From how far away must a species be dispersed to be considered nonnative? If not all natural communities are tightly coevolved, can invaders be considered more acceptable in some communities? Can the process of accommodation between native and invader itself be accepted as natural?

The subjective judgments required to implement an exotic species removal program also become evident upon reflection. How much change to resident populations must occur for the invader to be considered destabilizing? What elements of natural communities are to be preserved — simply the presence of existing species? their present relative abundances? their current gene frequencies? their present rates of flux in ecosystem functional parameters (production, nutrient circulation, etc.)? How long must the process of evolutionary accommodation between newcomer and residents last before the species can be considered naturalized or native?

Today's exotic may be tomorrow's naturalized species, if a naturalized species is defined as one that has been present so long among its associates that mutual coexistence (and dispersal) over a significant duration is demonstrated. In turn, it is unclear how long a species must be naturalized before it can be considered native. Has a species earned its right to native status after demonstrating persistence for 10,000 years? 1000 years? 100 years? The Leopold-based policy would say that even 50 years is acceptable as long as the species arrived before Europeans; but 125 years (as in the case of *Eucalyptus*) is not, if the plant arrived since European settlement.

The spirit of the Leopold Committee's report could be interpreted to mean that the management goal should be to tolerate the role of natural processes in dispersal, but to minimize the role of anthropogenic ones. Yet difficulties quickly emerge: should an exotic species, once established, be allowed to persist because its spread is occurring by natural means? Should a native species that was extirpated in historic times be reintroduced by human agency? Current park policies would discourage natural dispersal in the first instance and encourage human introductions in the second. These policies are widely accepted, though they have not lacked for controversy (e.g., removing feral horses from Barrier Islands National Seashore) or potential controversy (re-

Conservation Biology  
Volume 4, No. 3, September 1990

storing habitat for poison oak, *Toxicodendron*, or for wild currant [*Ribes* sp.], the alternate host for a fungal crop pest).

Other policies may prove more controversial. Should a native species be introduced in parks outside its range to hasten a range extension? This possibility is under discussion as a mitigation to climate change (Peters & Darling 1985). Should a native species be blocked from introduction if its genotype differs from that of local populations? Park managers in northern California recently opposed plans to plant the native poppy (*Eschscholzia californica*), the state's official flower, along roadsides, since seeds were obtained from nursery plants grown in Oregon. The assumption was that the genetic composition of the nursery stock differed from that of local genotypes in parks, and would reduce the fitness of the latter through cross-breeding (Bowman 1989).

These questions exemplify troublesome issues in current policy: the arbitrariness of designating the time of European contact, since it is only one point on a continuum of escalating human influence on biotic dispersal; the unpopularity of removing exotic species valued for recreation, or of reintroducing native economic or recreational pests; the difficulty of defending the genetic purity of local strains on hypothetical grounds. Beyond these particular cases looms a larger issue: if the process of invasion elicits adaptive responses, by what criteria shall the presence of an exotic species be judged harmful?

Legislation to control exotic plant species has been influenced heavily by the desire of the agricultural industry to control weeds. In California, for example, plants in native stands may be controlled if they pose a pest hazard to agriculture (Barbe 1985, in Mooney et al. 1986). As policies to protect biodiversity in public parks evolve, however, new tensions will arise. In particular, with limited public funds available for control of exotic plants within parklands, shall the exotics-control program be seen merely as an exercise in creating illusions of wilderness for historical and scientific interest, or shall efforts be focused on purging the elements known to be most ecologically disruptive?

### The State of the Science

The classic work on biological invasions by Elton (1958) focused ecologists' attention on the questions of why some species are more successful invaders than others, and why some habitats are more vulnerable to disruption than others. He also focused attention on management issues, noting that ecologically-based habitat manipulations could be used as tools to control exotic species. In the past decade, an important interna-

tional stock-taking on the ecology of biological invasions was undertaken under the auspices of the Scientific Committee on Problems of the Environment of the International Council of Scientific Unions (Groves & Burdon 1986; Kornberg & Williamson 1986; MacDonalld et al. 1986; Mooney & Drake 1986; Joenje et al. 1987; Drake & Mooney 1989; Usher 1988). Some major findings and research needs of relevance to management are summarized below.

1. *Not all invaders are equally successful, and many are not successful at all.* Although some unsuccessful invasions from inadvertent introduction have been documented (e.g., McKillup et al. 1988), the more abundant evidence of failures comes from introductions for biological control (Simberloff 1986; Hall & Ehler 1979). Most of this documentation refers to insects rather than plants.

The degree of change in host community composition induced by successful plant invaders varies along a continuum from species with modest resource usurpation spread across many competitors, resulting in no extirpations (e.g., Wilson & Sykes 1988), to species whose competitive pressure is focused on one or a few resident species. In the latter case, the successful invader may achieve significant competitive displacement (e.g., Tremmel & Peterson 1983). Plant species arriving from long distances may enjoy a period free of co-evolved herbivores and pathogens, thereby strengthening the competitive ability of the invading plant population.

2. *The success of invading species cannot be predicted on the basis of life-history characteristics alone, but some traits do appear predisposing.* Some traits helpful to successfully invading plant species include high population growth rates, abundant seed production, long-range dispersal ability, phenotypic plasticity, short generation times, and generalized pollination systems (wind, generalized insect, or self-pollination; Baker 1986; Bazzaz 1986). The nature of the host habitat can also cause the invasive potential of species to vary (Orlans 1986). Our ability to predict the success of particular invaders in particular habitats is as yet primitive.

3. *Habitat disturbance, natural or anthropogenic, is almost always helpful, if not essential, to plant invasions.* Natural habitats with open areas (semi-arid and arid areas; wetlands; woodlands) and habitats with frequent natural disturbance (fire, storm, flood) are subject to invasions (Braithwaite et al. 1989; McIntyre et al. 1988; Westman et al. 1975), though the most extensively studied cases of invasions occur in ecosystems with human disturbance regimes (farmlands, rangelands, and managed plantations; Elton 1958). Since all ecosystems are subject to some level of disturbance, none are free of invasive potential, but the frequency and intensity of gap disturbances are key.

4. *Ecosystem functioning can change with invasion,*

but the changes are not always substantial. Dramatic cases of changes in ecosystem function can result, for example, from invasion of nitrogen-fixing exotics in pioneer situations (e.g., Vitousek 1986; Braithwaite et al. 1989) or the invasion of grasses or forbs that change the prevailing fire frequency (e.g., *Bromus tectorum* in the West; Billings 1990; *Lolium multiflorum* in some chaparral stands; Zedler et al. 1983). Much less dramatic changes in functional rates apparently occur in the case of many invading species, but documentation is sparse.

5. *Species invasions are a natural process; communities do not migrate intact.* Biogeographic studies, both in geologic time (Davis et al. 1986; Huntley & Webb 1989; Pennington 1986; Webb 1986, 1987) and in historic time (Hengeveld 1988), have shown the tendency of species to change geographic ranges on an individualistic basis. Plant species and their pathogens will not always migrate at the same speed, resulting in partially nonoverlapping ranges. There are exceptions, of course, in the case of tightly coevolved plant-pollinator or plant-dispersal agent systems (e.g., fig and fig wasp; Kiester et al. 1984). The degree of adaptive response to a plant invader, particularly by wildlife, is known only from case studies; predictive generalizations are scant.

Though the process of invasion and population adjustment is not itself unnatural, the pace of introductions by human agency has clearly increased since the Pleistocene. It is this accelerated pace of invasion, driven both by enhanced dispersal events and increased habitat disturbance, that can act as a major destabilizing influence on the host community (e.g., Vitousek et al. 1987).

6. *Preadaptation can permit new plant species to fit into an existing assemblage without coevolution.* What appears to permit many plant species to migrate independently is the existence of generalized traits that enable the plant to survive among new cohabitants. Bazzaz (1987) and Wilson (1989) note this "preadaptation" phenomenon. Westman (1990) suggests that it derives from widespread "functional redundancy" among plants. Rummel and Roughgarden (1985) have referred to communities in which coevolution has not yet taken place as "invasion-structured." Wilson (1989) describes such an invasion-structured assemblage in which exotic plant species have integrated into an intermittently grazed grassland in little over a century.

Nevertheless, many resident species begin to adapt to the invader immediately, and genetic changes by population-level selection can sometimes be found in annual invader species within 25–40 years (e.g., *Bromus rubens* in central California, Westman et al. 1985; *Trifolium birtum* in California pasturelands, Martins & Jain 1980).

### Impacts of Exotic Species Removal on Ecosystem Structure and Function, and Conflict with Recreational Goals: The Case of *Eucalyptus* in California

While ecologists have been largely concerned with documenting the impact of exotic species on ecosystem structure and function, park managers must be concerned with whether the changes wrought are beneficial or detrimental to overall park management goals. These goals vary with the nature of the reserve: wilderness areas within national parks are mandated to place greater emphasis on biological conservation goals than nonwilderness or national recreation areas. By the Organic Act of 1916, U.S. national parks are to be managed both to conserve wildlife and to provide for the enjoyment of natural, scenic, and historic objects in perpetuity. How these goals are to be balanced is not specified in the Act, but is established through park management plans that are subject to periodic update and public review.

A consideration of the *Eucalyptus* removal program in California parks shows just how difficult it may be to achieve such a balance. Proposals to remove *Eucalyptus* from California parklands were made by federal and state park agencies, and plans had been implemented in some parks when a major public protest was launched. Of the 975 nonnative (including 674 naturalized) plant species in California (Raven & Axelrod 1978), *Eucalyptus* was one of a very few selected for attention. This selection resulted not from an ecological study to establish priorities, but largely because of the tree's prominence and because private loggers were offering to take the species off the hands of park officials for ten cents/ton for use in particle board and pulp. In the case of Angel Island State Park, the California Department of Parks and Recreation offered to pay loggers \$40,000 in bargaining costs to remove the trees, and budgeted at least an additional \$50,000 for site restoration in the first year, amounting to \$1,050 per acre of trees removed. This figure was virtually the entire exotic species management budget for the park.

The assumptions made at the start of the program were that removing an exotic species would necessarily favor the growth of native plant species, a process to be helped along by a park planting program; that native wildlife would benefit; that no ecosystem functions would be irreparably worsened; and that these goals would not interfere with human appreciation of park resources. As the program evolved, however, it became clear that these assumptions might not be wholly valid.

1. *Native plant species would be favored.* On Angel Island, the 86 acres of eucalypt were comprised of 23 acres planted by human agency and 63 acres of spread

in the past century. The park proposed to replace about half the eucalypt area with perennial grassland, and the remainder with oak woodland and coastal shrubland (California Department of Parks and Recreation 1988).

With one-third of the flora of the island composed of exotic species (Ripley 1980), the potential exists for cleared sites to be invaded by other exotic species: annual grasses such as *Avena barbata*; forbs, including several thistle species; and aggressive perennial shrubs such as the nitrogen-fixing broom, *Cytisus scoparius*. Once established, a number of these species are more difficult to control than eucalypts, since their time to first reproduction is shorter, seed dormancy less, and initial dispersal distances longer. Park officials indicated that if no more than 50 percent of the vegetative cover on restored grassland sites were exotic, the project would be judged successful (California Department of Parks and Recreation 1989). How successful park managers will ultimately be at controlling the more aggressive exotics, and at what financial cost over the long term, is unknown.

More generally, by focusing on the more readily controlled species park managers could gradually create partially restored landscapes populated by more resistant exotics. A determining factor will be the size of budgets available to manage the restoration process on a long-term basis.

2. *Native wildlife would benefit.* The initial assumption of park planners was that simply replacing *Eucalyptus* with native cover would necessarily favor native wildlife. As a result of public controversy about the plan, the state commissioned a several-month study of this and related issues (California Department of Parks and Recreation 1988). The time permitted for study was insufficient to permit an adequate understanding of the role these trees play in wildlife habitat compared to native replacements, yet it was apparent that the eucalypts were being utilized by a wide range of native species, in some cases preferentially. Of the bird species observed on the island, for example, 57 percent were found in both *Eucalyptus* and native oak woodlands, and 8 percent were found only in the eucalypts; total abundances were equal in the two stand types (Morrison & Keane 1988), though much remains unknown about actual habitat utilization behaviors. Populations of the principal salamander species (*Batrachoseps attenuatus*) were three times as dense in eucalypt stands as in native woodlands.

The western populations of the monarch butterfly, *Danaus plexippus*, which overwinter in coastal California, had two temporary bivouac sites on the island, both in *Eucalyptus* groves. Indeed, eucalypts were present at 75 percent of the 112 permanent or temporary monarch overwintering roosts surveyed in coastal California. Most of the trees at remaining sites were conifers

planted outside their natural range (data from Nagano & Lane 1985, cited in Westman 1990). Although the association between monarch and eucalypts is by no means exclusive, the statistical preference in the California survey suggests that some properties of eucalypts, such as their ability to provide both shelter and a nectar source, promote this behavior (Westman 1990).

Assuming that the utilization of the exotic host by these native animals is facultative rather than obligate, there remains the question of what the forest-dependent animals will survive on during the period of transition between the removal of the eucalypt forest and the growth of a mature oak woodland. Among territorial animals such as many forest bird species, suitable habitats are frequently saturated, so that a reduction in habitat area cannot be compensated for by increasing the density in the remaining habitat. An oak forest of equivalent stature to a 100-year-old eucalypt grove cannot be grown in less than several decades. The existing forest resource, albeit composed of exotic species, comprises an equity for wildlife that would be lost during any transition period.

3. *No ecosystem function would be irreparably worsened.* Effecting the transition from eucalypt forest to native habitat type (oak woodland, chaparral, perennial grassland) involves a series of changes in ecosystem flux rates.

The process of removal requires the use of heavy machinery, introducing risks of increased soil erosion. Erosion control measures were proposed by the park, including planting an exotic annual grass species that was naturalized on the island (*Vulpia megalura* = *Vulpia myuros* var. *hirsuta*; Lonard & Gould 1974). With cutting planned for early fall to minimize impact on both wildlife and human visitors (California Department of Parks and Recreation 1989), the removal ran the risk of being followed by early winter rains before erosion control measures could be fully implemented. In one area of eucalypt cover, the substrate consists of highly erodible sandy soil.

In coastal California, it has been common practice to use exotic grasses for erosion control on recently burned slopes. In southern California, a common species seeded in by aircraft is ryegrass, *Lolium multiflorum*. Where it has been successfully established, it has been reported to interfere with herb establishment (Keeley et al. 1981) and, at least in the short term, with chaparral shrub recovery (Schultz et al. 1955; Gautier 1982; Zedler et al. 1983). A key issue, as yet unresolved, is whether native species can achieve an adequate cover quickly enough to control erosion on disturbed slopes. Since herb growth typically follows the onset of winter rains by some weeks, bare slopes are exposed to high erosion rates in the first winter storms; an exotic species that can establish ground cover more quickly has clear

value in erosion control (Barro & Conard 1987). The long-term effects of exotic grass cover on recovery of native species are not extensively documented.

The reduction in evapotranspirative water loss due to forest clearing could result in standing water, as occurred following eucalypt clearing in Annadel State Park in California in 1986. In many parts of California, eucalypts were first planted in the nineteenth century as an antimalarial measure to dry up swamps (Friedman 1988; cf. lowering of groundwater by eucalypt planting in Portugal: Kardell et al. 1986). Of course, in wilderness areas where the forest is being replaced by native vegetation of lower water demand, the restitution of higher groundwater tables may be judged beneficial.

The reduction in standing phytomass would also result in a net release of carbon dioxide (a greenhouse gas) to the atmosphere, and a reduction in foliage for absorption of other pollutants. The removal of these trees, which were originally introduced to Angel Island by the government, would occur at a time when government agencies are reembarquing on a tree-planting program. By replacing 80 percent of the eucalypt acreage with grassland or shrubland, the fuel load would decrease, but the potential for ignitions would persist; prescribed burning would be necessary in any event to reduce fire hazard to built structures.

In short, rates of flux in ecosystem functions on the site would change substantially (carbon fixation; erosion control; evapotranspiration; pollution absorption). Herbicides (glyphosate; triclopyr) would also be used to prevent resprouting from cut tree bases. The trade-offs may be judged acceptable to achieve restoration goals; in most cases, however, this judgment can not be reached without a thorough impact assessment.

4. *Exotic species removal will not interfere with human appreciation of park resources.* The biodiversity goals of an exotic species removal program may be in conflict with the recreational and aesthetic goals of a significant fraction of park users. On Angel Island, for example, some of the eucalypt groves shade picnic areas and hiking trails, and conceal road scars.

An evaluation of the aesthetic qualities of the landscape is necessarily a subjective task, most reasonably done by reference to the values of the multiple publics affected (Westman 1985). An exit survey of 120 visitors to the island on one day in the summer of 1987 revealed that 98 percent of the visitors opposed the removal of eucalypts from the island, even though not all visitors were aware of their taxonomic identity. The appearance, fragrance, rustle, and shade of the trees were all cited in their favor by individual interviewees. Many expressed an emotional attachment to trees. For these "generalized tree lovers," the exotic status of the eucalypt was irrelevant to enjoyment of the species.

The organized opposition to *Eucalyptus* on the island was led by park staff and supported by a range of envi-

ronmental groups. Their opposition was based primarily on the fact that the species was not native and was displacing native habitat. Thus the opposing groups conceptualized the object at issue in nonparallel ways: supporters of eucalypts saw the object largely in terms of the amenities provided by its structure; opponents saw the object in terms of its geographic origin and evolutionary history.

One possible compromise for generalized tree lovers would have been to conduct highly selective cutting of eucalypts to create gaps in which native oaks could be established. Eucalypt cutting would be completed in phases so that the same total forest cover was retained throughout the process. This possibility was rejected by park authorities on the grounds that selective cutting would be too costly; commercial loggers would not find such procedures profitable, and the logging would have to be done by the park. Park authorities also speculated that selective logging might be too disruptive to recovering vegetation (California Department of Parks and Recreation 1988).

As to replacement of exotic trees by native shrubs or grasses, clearly there was no compromise possible that would satisfy generalized tree lovers.

#### Setting Priorities

The effort expended on replacing particular exotics with native species should appropriately vary with the differing goals of particular park types. Different park units (wilderness areas, national parks, national recreation areas, city parks, etc.) are committed to different levels of balance between recreational use and wilderness maintenance. It seems appropriate that those units with a greater emphasis on recreational uses and less on maintenance and scientific study of natural ecosystems should put more emphasis on the structural and functional values (positive and negative) of exotic species and less emphasis on ancestry alone.

Implementation of such a policy would ideally require extensive knowledge of the ecological role that exotic species are currently playing in the park setting. As seen with the eucalypt case study, some native species had already begun to adapt to the presence of the exotic. Much more information would be needed, however, to understand the changes in the pre-existing ecosystem that occurred as a result of the introduction of the exotic species. Predicting the impact of the removal and restoration process is even more difficult.

Once completed, such a study would not give absolute answers about whether a particular exotic species should be removed. Weighed against the values of the multiple publics, some species will appear more valuable to retain than others. In accordance with the thrust of current federal law dealing with park management, the value of pure assemblages of native species must be



weighed against other social values. The main ecological argument conservation biologists have to make in this debate is that older species associations have evolved more homeostatic mechanisms for maintaining ecosystem structure and function and may therefore serve multiple park goals most cost-effectively. The assumption is that mixed native-exotic communities would be more costly to manage at a desired level of functioning; in practice, this assumption must be retested in each case.

Given a limited budget for ecosystem management in public parks and limited information on the impact of particular exotic species on ecological and human resources, how shall priorities for exotic plant species management be set? At Hawaii Volcanoes National Park, priority is given to the most biotically intact areas and those with rare or endangered plant species. Exotic species that are localized and are therefore more readily eradicated, are targeted. Exotic species that are viney, readily dispersed, aggressive in rate of spread as shown by experience elsewhere, or closely related taxonomically to a native species are given higher priority for control (Hawaii Volcanoes National Park 1988).

Adverse impact on ecosystem function has been used at Hawaii Volcanoes as a basis for targeting control of fountain grass (*Pennisetum setaceum*). This exotic grass species is highly flammable compared to natives, and thus can increase fire frequency and intensity on the island.

Not all of these criteria may be universally applicable, and others might well be added: the adverse effect of exotic species removal on ecosystem structure and function (impact on native wildlife, soil binding, etc.); the effect on human recreational uses of the park (shading, wildlife habitat, aesthetic qualities, historical values); the difficulty of replacement with native species (cost, time required, availability of technical knowledge on restoration). Unfortunately, implementing these criteria is more difficult since it requires knowledge that frequently does not exist, particularly on the current extent of interrelation of native and exotic species. As more restoration projects are undertaken, the need for fundamental research on the current functioning of mixed exotic-native ecosystems and on the impact of species removal will increase. Such studies will also have much to contribute to our understanding of competition and the evolution of assemblages (e.g., Pimm & Gilpin 1989; Roughgarden 1989).

### The Policy Implications of Shifting Ecological Paradigms

The debate over exotic species policy has its roots in part in the early arguments between those supporting the individualistic hypothesis (H. Gleason, L. Ramensky)

and those supporting an organismic view of communities (F. C. Clements). The assumption that all exotics are inherently unnatural rests on a view of plant communities as unchanging entities across time and space. Paleobiogeographic and modern data on dispersal indicate that immigration and extinction processes for plants occur largely as individualistic processes over time. Furthermore, the spatial variation of vegetation composition across environmental gradients (Whittaker 1967) indicates that species are continually adapting to different assemblages and relative abundances of coassociated species across landscape space.

The assumption that all exotic species are equally disruptive also stems from the organismic view of communities, in which a loss of any species was seen as a threat to the whole. While there are unquestioned coevolutionary dependencies between plants and their pollinators and dispersal agents, the codependence of plant species (with the exception of parasites and symbionts) has generally been demonstrated to be generalized rather than species-specific. That is, while there are unquestionably interactions within the trophic level (above-ground competition for light, root competition for nutrients, water), there may be a substantial functional redundancy within the trophic level: one fast-growing plant species can be as effective as another in shading a slower-growing competitor.

The practical implication of the current individualistic paradigm in theoretical ecology is that each exotic species must be evaluated on an individual basis for its effect on ecological and human resources. A further implication is that priorities for exotic species management should be set, with attention focused on the current and future ecological role of the species in relation to existing natives, as well as the impact of removal on other park resources and goals. There are currently proposals to move U.S. national park policies further in this direction (T. Tunison, Hawaii Volcanoes National Park, 1989, personal communication regarding Natural Resource Management Guideline NPS-77).

Such an approach will be put to a severe test if the predicted increase in invasion of species by range extension as a result of global climatic change comes to pass (EPA 1988; Westman & Malanson 1990). With climatic change, extensions in the range of both native and introduced species are expected. With the increased mortality of residents under rapid climatic change, gaps will be created that will probably favor introduced species that have already escaped their predators and pathogens. These species will pose mixed blessings to park managers: some may provide important soil-stabilizing and wildlife-support functions to an ecosystem in transition, yet those with strong competitive abilities may accelerate the loss of native species.

Under such circumstances, the need for research to evaluate and predict the impact of the invader on struc-

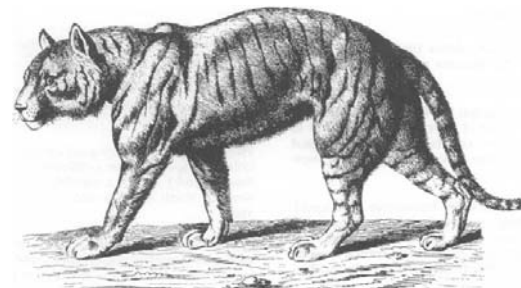
ture and function in the existing ecosystem and landscape, and to establish generalizations, will take on new urgency. Research will be needed to identify species or guild properties that will minimize structural and functional changes to the ecosystem, on the assumption that stable ecosystems will also support other park goals. With emphasis placed on both functional and structural roles, the information required for decision-making will be increased. By using ecological role rather than simply ancestry as a basis for evaluating the impact and worth of the invader, however, the ecosystem-level goals of park management may be better served.

### Literature Cited

- Baker, H. G. 1986. Patterns of plant invasions in North America. Pages 44–57 in H. A. Mooney and J. A. Drake, editors. *Ecology of biological invasions of North America and Hawaii*. Springer-Verlag, New York.
- Barbe, D. 1985. The role of the California Department of Food and Agriculture. *Fremontia* 13:13–14.
- Barro, S. C., and S. G. Conard. 1987. Use of ryegrass seeding as an emergency revegetation measure in chaparral ecosystems. General Technical Report PSW-102, USDA Forest Service Pacific Southwest Forest and Range Experiment Station.
- Bazzaz, F. A. 1986. Life history of colonizing plants: some demographic, genetic, and physiological features. Pages 96–110 in H. A. Mooney and J. A. Drake, editors. *Ecology of biological invasions of North America and Hawaii*. Springer-Verlag, New York.
- Bazzaz, F. A. 1987. Experimental studies on the evolution of niche in successional plant populations. Pages 245–272 in A. J. Gray, M. J. Crawley, and P. J. Edwards, editors. *Colonization, succession and stability*. Symposia of the British Ecological Society, 26. Blackwell Scientific Publications, Oxford, England.
- Billings, W. D. 1990. Grasslands. In G. M. Woodwell, editor. *The Earth in transition. Patterns and processes of biotic impoverishment*. Cambridge University Press, New York. In press.
- Bowman, C. 1989. Flap over plan to plant poppies. *San Francisco Chronicle*, November 17.
- Braithwaite, R. W., W. M. Lonsdale, and J. A. Estbergs. 1989. Alien vegetation and native biota in tropical Australia: the impact of *Mimosa pigra*. *Biological Conservation* 48:189–210.
- Cairns, J., Jr. 1989. Restoring damaged ecosystems: is predisturbance condition a viable option? *The Environmental Professional* 11:152–159.
- California Department of Parks and Recreation. 1979. Resource management directives for the California Department of Parks and Recreation. Sacramento, California.
- California Department of Parks and Recreation. 1988. Focused environmental study. Restoration of Angel Island natural areas affected by Eucalyptus. Sacramento, California. 290 pp.
- California Department of Parks and Recreation. 1989. Draft environmental impact report. Restoration of Angel Island natural areas affected by Eucalyptus. Jones and Stokes Associates, Sacramento, California.
- Davis, M. B., K. D. Woods, S. L. Webb, and R. P. Putyama. 1986. Dispersal versus climate: expansion of *Fagus* and *Tsuga* into the Upper Great Lakes region. *Vegetatio* 67:93–104.
- Drake, J., and H. A. Mooney. 1989. Ecology of biological invasions: a global perspective. Wiley, New York. 450 pp.
- Elton, C. S. 1958. *The ecology of invasions by animals and plants*. Methuen, London, England. 181 pp.
- Environmental Protection Agency. 1988. *The potential effects of global climate change on the United States*. Volume 2. National Studies. EPA, Washington, D.C.
- Friedman, R. 1988. Strangers in our midst. *Pacific Discovery*, Summer. Pp. 22–31.
- Gautier, C. R. 1982. The effects of ryegrass on erosion and natural vegetation recovery after fire. Page 599 in *Dynamics and management of Mediterranean-type ecosystems*. General Technical Report PSW-58, USDA Forest Service, Pacific Southwest Forest and Range Experiment Station, Berkeley, California.
- Groves, R. H., and J. J. Burdon, editors. 1986. *The ecology of biological invasions: an Australian perspective*. Cambridge University Press, Cambridge, England. 166 pp.
- Hall, R. W., and L. E. Ehler. 1979. Rate of establishment of natural enemies in classical biological control. *Bulletin of the Entomological Society of America* 25:280–282.
- Hawaii Volcanoes National Park. 1988. *Natural resources management plan and environmental assessment*. U.S. Department of Interior, National Park Service, Hawaii.
- Hengeveld, R. 1988. Mechanisms of biological invasions. *Journal of Biogeography* 15:819–828.
- Huntley, B., and T. Webb, III. 1989. Migration: species' response to climatic variations caused by changes in the Earth's orbit. *Journal of Biogeography* 16:5–19.
- Joenje, W., K. Bakker, and L. Vlijm, editors. 1987. *The ecology of biological invasions*. Proceedings of the Koninklijke Nederlandse Akademie van Wetenschappen 90:1–80.
- Jordan, W. R., III, M. E. Gilpin, and J. D. Aber, editors. 1988. *Restoration ecology. A synthetic approach to ecological research*. Cambridge University Press, New York. 352 pp.
- Kardell, L. E. Steen, and A. Fabio. 1986. *Eucalyptus* in Portugal — a threat or a promise? *Ambio* 15:6–13.
- Keeley, S. C., J. E. Keeley, S. M. Hutchinson, and A. W. Johnson. 1981. Postfire succession of the herbaceous flora in southern California chaparral. *Ecology* 62:1608–1621.
- Kiester, A. R., R. Lande, and D. W. Schemske. 1984. Models of coevolution and speciation in plants and their pollinators. *American Naturalist* 124:220–243.

- Kornberg, H., and M.H. Williamson. 1986. Quantitative aspects of the ecology of biological invasions. *Philosophical Transactions of the Royal Society of London, B, Biological Sciences* 314:501-746.
- Leopold, A.S., S.A. Cain, C.M. Cottam, I.N. Gabrielson, and T.L. Kimball. 1963. Wildlife management in the national parks. Department of the Interior, Washington, D.C. 14 pp.
- Lonard, R., and F.W. Gould. 1974. The North American species of *Vulpia* (Gramineae). *Madroño* 22:217-230.
- MacDonald, I.A.W., F.J. Kruger, and A.A. Ferrar, editors. 1986. The ecology and management of biological invasions in southern Africa. Oxford University Press, Cape Town, South Africa.
- Martins, P.S., and S.K. Jain. 1980. Interpopulation variation in rose clover. *Journal of Heredity* 71:29-32.
- McIntyre, S., P.Y. Ladiges, and G. Adams. 1988. Plant species richness and invasion by exotics in relation to disturbance of wetland communities on the Riverine Plain, NSW. *Australian Journal of Ecology* 13:361-373.
- McKillop, S.C., P.G. Allen, and M.A. Skewes. 1988. The natural decline of an introduced species following its initial increase in abundance; an explanation for *Ommatolulus moreletii* in Australia. *Oecologia* 77:339-342.
- Mooney, H.A., and J.A. Drake, editors. 1986. Ecology of biological invasions of North America and Hawaii. Springer-Verlag, New York. 321 pp.
- Mooney, H.A., S.P. Hamburg, and J.A. Drake. 1986. The invasion of plants and animals into California. Pages 250-275 in H.A. Mooney and J.A. Drake, editors. Ecology of biological invasions of North America and Hawaii. Springer-Verlag, New York.
- Morrison, M.L., and J. Keane. 1988. Preliminary final report, wildlife-habitat relationships in *Eucalyptus* groves on Angel Island State Park, California. Pages 95-102 in Focused environmental study. Restoration of Angel Island natural areas affected by *Eucalyptus*. California Department of Parks and Recreation, Sacramento, California.
- Nagano, C., and J. Lane. 1985. A survey of the location of monarch butterfly (*Danaus plexippus* L.) overwintering roosts in the state of California, USA: first year, 1984/85. Report U.S.-374. World Wildlife Fund, Washington, D.C.
- Orians, G.H. 1986. Site characteristics favoring invasions. Pages 133-148 in H.A. Mooney and J.A. Drake, editors. Ecology of biological invasions of North America and Hawaii. Springer-Verlag, New York.
- Pennington, W. 1986. Lags in adjustment of vegetation to climate caused by the pace of soil development: evidence from Britain. *Vegetatio* 67:105-118.
- Peters, R., and J. Darling. 1985. The greenhouse effect and nature reserves. *BioScience* 35:707-717.
- Pimm, S.L., and M.E. Gilpin. 1989. Theoretical issues in conservation biology. Pages 287-305 in J. Roughgarden, R. May, and S. Levin, editors. Perspectives in theoretical ecology. Princeton University Press, Princeton, New Jersey.
- Raven, P., and D. Axelrod. 1978. Origin and relationships of the California flora. University of California Publications in Botany 72:1-134.
- Ripley, J.D. 1980. Plants of Angel Island, Marin County, California. *Great Basin Naturalist* 40:385-407.
- Roughgarden, J. 1989. The structure and assembly of communities. Pages 203-226 in J. Roughgarden, R. May, and S. Levin, editors. Perspectives in theoretical ecology. Princeton University Press, Princeton, New Jersey.
- Rummel, J., and J. Roughgarden. 1985. A theory of faunal buildup for competition communities. *Evolution* 43:1009-1033.
- Schultz, A.M., J.L. Launchbaugh, and H.H. Biswell. 1955. Relationship between grass density and brush seedling survival. *Ecology* 36:226-238.
- Simberloff, D. 1986. Introduced insects: a biogeographic and systematic perspective. Pages 3-26 in H.A. Mooney and J.A. Drake, editors. Ecology of biological invasions of North America and Hawaii. Springer-Verlag, New York.
- Tremmel, D.C., and K.M. Peterson. 1983. Competitive subordination of a Piedmont old field successional dominant by an introduced species. *American Journal of Botany* 70:1125-1132.
- Usher, M.B. 1988. Biological invasions of nature reserves: a search for generalizations. *Biological Conservation* 44:119-135.
- Vitousek, P.M. 1986. Biological invasions and ecosystem properties: can species make a difference? Pages 163-178 in H.A. Mooney and J.A. Drake, editors. Ecology of biological invasions of North America and Hawaii. Springer-Verlag, New York.
- Vitousek, P.M., L.L. Loope, and C.P. Stone. 1987. Introduced species in Hawaii: biological effects and opportunities for ecological research. *Trends in Research in Ecology and Evolution* 2:224-227.
- Webb, T., III. 1986. Is vegetation in equilibrium with climate? How to interpret late-Quaternary pollen data. *Vegetatio* 67:75-91.
- Webb, T., III. 1987. The appearance and disappearance of major vegetational assemblages: long-term vegetation dynamics in eastern North America. *Vegetatio* 69:177-187.
- Westman, W.E. 1985. Ecology, impact assessment, and environmental planning. Wiley-Interscience, New York. 535 pp.
- Westman, W.E. 1990. Managing for biodiversity: unresolved science and policy issues. *BioScience* 40:26-33.
- Westman, W.E., and G.P. Malanson. 1990. Effects of climate change on Mediterranean-type ecosystems in California and Baja California. In R. Peters and T. Lovejoy, editors. Consequences of the greenhouse effect for biological diversity. Yale University Press, New Haven, Connecticut. In press.

- Westman, W.E., F.D. Panetta, and T. Stanley. 1975. Ecological studies on reproduction and establishment of the woody weed, groundsel bush (*Baccharis halimifolia* L.: Asteraceae). *Australian Journal of Agricultural Research* 26:855-870.
- Westman, W.E., K.P. Preston, and L.B. Weeks. 1985. Sulfur dioxide effects on the growth of native plants. Pages 264-280 in W.E. Winner, H.A. Mooney, and R. Goldstein, editors. Sulfur dioxide and vegetation — physiology, ecology, and policy issues. Stanford University Press, Stanford, California.
- Whittaker, R.H. 1967. Gradient analysis of vegetation. *Biological Reviews* 42:207-264.
- Wilson, J.B. 1989. Relations between native and exotic plant guilds in the Upper Clutha, New Zealand. *Journal of Ecology* 77:223-235.
- Wilson, J.B., and M.T. Sykes. 1988. Some tests for niche limitation by examination of species diversity in the Dunedin area, New Zealand. *New Zealand Journal of Botany* 26:237-244.
- Zedler, P.H., C.R. Gautier, and G.S. McMaster. 1983. Vegetation change in response to extreme events: the effects of a short interval between fires in California chaparral and coastal scrub. *Ecology* 64:809-818.



## Frequently Asked Questions In-Use Off-Road Diesel Vehicle Regulation

### Best Available Control Technology (BACT) FAQ Revised August 2014

**Q – What is BACT, and how do I comply with the fleet average requirements using BACT?**

A – BACT stands for Best Available Control Technology. In the context of the Off-Road Regulation, BACT is one way of satisfying the regulation's performance requirements. Each year, a fleet must determine if it will be able to meet the fleet average requirements in the Off-Road Regulation for the next January 1<sup>st</sup> compliance date (beginning 2014 for a large fleet, 2017 for a medium fleet, and 2019 for a small fleet). If not, it must meet BACT requirements by turning over or installing VDECS on a percentage of its total fleet horsepower (hp) that is subject to BACT requirements (section 2449.1(b)(1)). The Off-Road Regulation's required annual BACT rates for each fleet size are as follows:

Fleet Size	Year	BACT Rate
Large (> 5,000 hp)	2014	4.8%
	2015 to 2017	8%
	2018 to 2023	10%
Medium (2,501 – 5,000 hp)	2017	8%
	2018 to 2023	10%
Small (≤ 2,500 hp)	2019 to 2028	10%

**Example:** For the January 1, 2014 compliance date, a large fleet with 10,000 total hp would be required to either meet the fleet average requirements or turn over (or install VDECS on) 480 hp in the twelve months prior to January 1, 2014. Turnover could consist of retiring vehicles, designating vehicles as permanent low-use, repowering vehicles with a higher tier engine, or rebuilding the engines to a more stringent emissions configuration.

DOORS automatically calculates the fleet's required BACT amount each year and displays it in the Compliance Snapshot, a page available in the fleet's DOORS account.

*While this document is intended to assist fleets with their compliance efforts, it does not alter or modify the terms of any ARB regulation, nor does it constitute legal advice. It is the sole responsibility of fleets to ensure compliance with the In-Use Off-Road Diesel-Fueled Fleets Regulation.*

**Q – Is there an order I must follow in choosing which vehicles/engines I must perform actions on to satisfy the BACT requirements?**

A – Yes; all Tier 0 and Tier 1 engines in a fleet, except those in vehicles that qualify for an exemption from the BACT requirements, must be turned over (i.e., retired, repowered, or designated as permanent low-use) before the turnover of any other higher tier engines may be counted toward the BACT requirements or toward accumulating carryover BACT credit. A fleet may, however, receive carryover BACT credit (per sections 2449.1(b)(10) and 2449.1(b)(15) in the Off-Road Regulation) for a VDECS installed on an engine, regardless of the engine's tier. For additional information on conditions that make a vehicle exempt from BACT requirements, please see the BACT Exemptions FAQ at <http://www.arb.ca.gov/msprog/ordiesel/faq/bactexemptionsfaq.pdf>.

Please note that DOORS automatically determines the engine tier for each off-road diesel vehicle based on the engine's hp and model year. You may use the table on page 1 of the Fleet Average FAQ, which is available at <http://www.arb.ca.gov/msprog/ordiesel/faq/fleetaverage.pdf>, to determine your engine tiers yourself. You may also locate the engine tier for your off-road vehicles as determined by DOORS, by logging into your DOORS account and proceeding to the "Vehicle & Engine" page.

**Q – If I turn over more vehicles than required to meet my BACT requirements, do I get to use that "credit" later?**

A – Yes; a fleet will accumulate carryover BACT credit each year it exceeds the BACT requirements, and accumulated carryover BACT credit may be applied to meeting the BACT requirements in a later year. The amount of carryover BACT credit used to meet the BACT requirements in any one year is subtracted from the accumulated carryover BACT credit total, with the remainder being available for use in subsequent years.

**Example:** Fleet A is a large fleet with 10,000 total max hp as of December 31, 2013. The fleet had a BACT requirement of 800 hp to meet for the January 1, 2015 compliance date (8% of its total max hp). To meet its BACT requirement, the fleet retired 1,000 hp of its Tier 0 and Tier 1 vehicles and installed VDECS on 1,000 hp of its remaining vehicles, for a total of 2,000 hp in BACT credit. This left the fleet with 1,200 hp in carryover BACT credit to be used to meet the fleet's BACT requirement for January 1, 2016.

*While this document is intended to assist fleets with their compliance efforts, it does not alter or modify the terms of any ARB regulation, nor does it constitute legal advice. It is the sole responsibility of fleets to ensure compliance with the In-Use Off-Road Diesel-Fueled Fleets Regulation.*

**Q – I have electric vehicles in my fleet. Will that affect my fleet average requirements or BACT requirements?**

A – Yes; electric vehicles are not included in determining fleet size, or when calculating the required hp for the BACT requirements. However, electric vehicles are accounted for in a fleet's emissions averages. This is beneficial to a fleet, as electric vehicles have an emission factor of zero.

For more information on emission factors to use for electric vehicles, and the criteria that must be met in order for a fleet to include an electric vehicle in its off-road fleet, please see the Emission Factors FAQ, which is available in the Knowledge Center at <http://www.arb.ca.gov/msprog/ordiesel/documents/emissionfactorsfaq.pdf>.

**Q – What if I don't meet the final fleet average target by the final compliance date?**

A – After the final compliance date (January 1, 2023 for large and medium fleets and January 1, 2028 for small fleets), if a fleet does not meet the final fleet average target, they must continue to meet BACT requirements (described above) and report annually each year until they meet the final fleet average target.

Previously earned BACT carryover credit cannot be used to meet compliance requirements after the final target date. Instead, a fleet must continue to take action on 10% of their fleet each year until the final fleet average target is met. Vehicles exempt from BACT are also exempt from compliance requirements after the final target date. For additional information on conditions that make a vehicle exempt from BACT requirements, please see the BACT Exemptions FAQ, which is available in the Knowledge Center at <http://www.arb.ca.gov/msprog/ordiesel/faq/bactexemptionsfaq.pdf>.

**Q – What if a fleet met the final target with year-by-year low-use vehicles, but then brought the vehicles out of low-use after the final target date?**

A – Vehicles that formerly met the year-by-year low-use definition, but whose use increases to 200 hours per year or greater must be included in the fleet average calculations by the next compliance date. If the fleet can no longer meet the final fleet average target because the low-use vehicles are now included in the fleet average, the fleet must meet BACT requirements each year until it does so.

**Example:** *Fleet L is a large fleet who met its January 1, 2023 final fleet average target with 10 Tier 0 vehicles designated as year-by-year low-use. However, 6 of the fleet's 10 vehicles were used over 200 hours in 2025, which brought the vehicles back into the fleet average calculations as of January 1, 2026. This*

*While this document is intended to assist fleets with their compliance efforts, it does not alter or modify the terms of any ARB regulation, nor does it constitute legal advice. It is the sole responsibility of fleets to ensure compliance with the In-Use Off-Road Diesel-Fueled Fleets Regulation.*

*caused the fleet's fleet average index to exceed the final fleet average target. The fleet is then required to meet a BACT rate of 10% of their fleet's total max hp, beginning January 1, 2026 and each January 1<sup>st</sup> thereafter until they again meet the January 1, 2023 final fleet average target.*

**Q – What are my options for meeting the performance requirements of the Off-Road Regulation?**

A – To be in compliance on a compliance date, a fleet must either bring its fleet average index to, or below, the fleet average target rate or satisfy the BACT requirements. Each year, a fleet should consider what it would take to meet the fleet average target rate and if that action is more costly than complying with the BACT requirements for the next year, the fleet should comply with the BACT requirements and wait until a later year to meet the fleet average target rate.

The following are the possible ways a fleet may reduce its fleet average index and comply with the BACT requirements (listed approximately in order of increasing per vehicle cost):

- **Designate a vehicle as low-use** – If a fleet has a vehicle that it needs occasionally but not more than 200 hours per year, that vehicle would qualify for the low-use designation. When a vehicle is designated as low-use, the fleet is certifying that that vehicle has been or will be used no more than 200 hours per year (for more details on low-use designation, see also the Low-Use Provisions FAQ at <http://www.arb.ca.gov/msprog/ordiesel/faq/lowusefaq.pdf>). Vehicles permanently designated as low-use or designated as year-by-year low-use are not counted toward a fleet's fleet average index. Hence, designating lower tier (higher emitting) vehicles as low-use will lower a fleet's fleet average index and is one way to move closer to the fleet average target rate. Designating a vehicle as permanent low-use also counts toward a fleet's annual BACT requirements. For example, designating a 100 hp vehicle as permanent low-use would generate 100 hp BACT credit.
- **Retire a vehicle** – If a fleet has an older, higher tier vehicle it can do without, it may wish to consider removing that vehicle from the fleet. Selling or retiring a lower tier (higher emitting) vehicle will lower a fleet's fleet average index and move the fleet closer to the fleet average target rate. Selling or retiring a lower tier vehicle also counts toward a fleet's annual BACT requirements (all Tier 0 and Tier 1 vehicles must be turned over before the turnover of higher tier vehicles can count toward BACT requirements). For example, selling a 100 hp Tier 0 vehicle would generate 100 hp BACT credit.

*While this document is intended to assist fleets with their compliance efforts, it does not alter or modify the terms of any ARB regulation, nor does it constitute legal advice. It is the sole responsibility of fleets to ensure compliance with the In-Use Off-Road Diesel-Fueled Fleets Regulation.*

- **Repower a vehicle** – In some cases, it is possible to replace an old engine with a cleaner, lower-emitting one (i.e., to repower the vehicle). If a fleet repowers a vehicle with a Tier 0 or 1 engine with a Tier 2 or higher engine, it will move the fleet closer to the fleet average target rate and accumulate BACT credit equal to the hp of the engine removed. For example, repowering a vehicle with a 100 hp Tier 0 engine with a 100 hp Tier 2 engine would generate 100 hp BACT credit. More information on repowering off-road vehicles with on-road engines is available at <http://www.arb.ca.gov/msprog/ordiesel/guidance/onroadengineadvisor.pdf>.
- **Install a VDECS** – When a verified device is available and may be safely installed on a vehicle, retrofitting with a VDECS (typically a diesel particulate filter) may be a cost-effective compliance option. Installing VDECS will be most attractive for vehicles that are expensive to replace and are likely to be kept for a number of years. Installing VDECS moves a fleet closer to its fleet average target rate (even for VDECS that reduce particulate matter only), and accumulates BACT credit. More information on how credit for VDECS is awarded is available at [http://www.arb.ca.gov/msprog/ordiesel/faq/vdecs\\_credit\\_faq.pdf](http://www.arb.ca.gov/msprog/ordiesel/faq/vdecs_credit_faq.pdf).
- **Replace a vehicle** – A fleet may replace an older, higher tier vehicle with a cleaner lower tier vehicle. Removing the older vehicle from the fleet or designating it permanent low-use will count as described above under “Designate a vehicle as low-use” and “Retire a vehicle”. The replacement vehicle must meet the off-road regulation’s adding vehicles requirements (discussed further in the Adding Vehicles FAQ at <http://www.arb.ca.gov/msprog/ordiesel/faq/addingvehicles.pdf>).

Credit may also be obtained under several uncommon and more specialized ways of complying with the off-road regulation; for example, replacing diesel vehicles with electric vehicles or alternative fuel vehicles, replacing diesel vehicles with a portable or electric stationary system such as a conveyor system, or rebuilding lower tier engines to a higher tier. Refer to the regulation for detailed provisions regarding these uncommon compliance options.

ARB staff has provided several tools for helping fleets evaluate various compliance options:

- **DOORS Compliance Snapshot** – The Diesel Off-Road Online Reporting System (DOORS) Compliance Snapshot is a page inside each fleet’s DOORS account that shows where the fleet stands with regard to the next compliance date, upcoming fleet average targets and BACT requirements.

*While this document is intended to assist fleets with their compliance efforts, it does not alter or modify the terms of any ARB regulation, nor does it constitute legal advice. It is the sole responsibility of fleets to ensure compliance with the In-Use Off-Road Diesel-Fueled Fleets Regulation.*

The information contained in the Compliance Snapshot is based on the information reported by the fleet in DOORS. The Compliance Snapshot calculates a fleet’s total max hp, fleet average targets, fleet average index, required BACT amounts, and BACT credits. More information on the Compliance Snapshot is available at <http://www.arb.ca.gov/msprog/ordiesel/faq/compliancesnapshotfaq.pdf>.

- **Fleet Average Calculator** – The Fleet Average Calculator is an Excel spreadsheet designed to assist fleet owners in calculating their Fleet Average Index and Fleet Average Targets based on the equipment model year and hp input. The calculator allows fleet owners to experiment with different turnover, repower, and retrofit strategies to plan for compliance. A Fleet Average Calculator User Guide is available at <http://www.arb.ca.gov/msprog/ordiesel/documents/revisedfacguide2013.pdf>.

ARB staff is continuously working to improve and expand our electronic compliance assistance tools. Fleets who would like personal help exploring compliance options are encouraged to call the DOORS hotline at 877-59DOORS (877-593-6677).

**Q – How can repowering my vehicle with a newer engine or rebuilding its engine help me comply? What happens to my credits if I sell a vehicle that has been repowered?**

A – A fleet can generate BACT credit by repowering a vehicle with a higher-tiered engine. For “early repowers” (i.e., repowers completed before a fleet’s initial compliance year begins), a fleet can only claim credit if it still owns the repowered vehicle (in other words, it cannot claim credit for vehicles that were repowered but sold to another fleet). “Early repowers” are those completed prior to the following dates:

- Large fleets: January 1, 2013;
- Medium fleets: January 1, 2016;
- Small fleets: January 1, 2018.

For repowers completed on or after the dates above, the credit will stay with the fleet that paid for the repower until such a time as it is claimed to meet future BACT requirements, even if the fleet subsequently sells the repowered vehicle. The buyer of the vehicle will not benefit from any of those credits but will benefit from the lower emission factor of the newer engine.

*While this document is intended to assist fleets with their compliance efforts, it does not alter or modify the terms of any ARB regulation, nor does it constitute legal advice. It is the sole responsibility of fleets to ensure compliance with the In-Use Off-Road Diesel-Fueled Fleets Regulation.*

## Frequently Asked Questions In-Use Off-Road Diesel Vehicle Regulation

### Off-Road Engine Tier Lifetime November 2014

**Q – Can I still add a Tier 0 or Tier 1 engine to my fleet?**

A – As of January 1, 2014, a vehicle with a Tier 0 engine may not be added to any fleet, and large and medium fleets may no longer add a vehicle with a Tier 1 engine to their fleets. Small fleets may add Tier 1 engine vehicles to their fleet through 12/31/2015. However, adding older, higher-emission Tier 1 engines to a fleet can create a burden on a small fleet's ability to meet the fleet average target rate in the future.

The restrictions for adding older vehicles to a fleet are further explained and illustrated below.

#### Adding Vehicle Requirements by Fleet Size and Calendar Year (Minimum Engine Tier Allowed to be Added to a Fleet)

Fleet Size	2014	2015	2016	2017	2018	2019	2020	2021	2022	2023
Medium/Large	T2				T3					
Small	T1		T2						T3	

**Ban on adding Tier 0s** – Beginning January 1, 2014, a fleet may not add a vehicle with a Tier 0 engine.

**Ban on adding Tier 1s** – Beginning January 1, 2014, for large and medium fleets, and January 1, 2016, for small fleets, a fleet may not add any vehicle with a Tier 1 engine. The engine tier of any vehicle added to a fleet must be Tier 2 or higher.

**Ban on adding Tier 2s** – Beginning January 1, 2018, for large and medium fleets, and January 1, 2023, for small fleets, a fleet may not add a vehicle with a Tier 2 engine. The engine Tier of any vehicle added to a fleet must be Tier 3 or higher.

**Q – How long is a Tier 0 or Tier 1 engine vehicle able to stay in my fleet before it is phased out or needs to be upgraded?**

A – Fleets may continue to have Tier 0 and Tier 1 vehicles until turnover of the vehicle(s) is needed to meet fleet average or Best Available Control Technology

*While this document is intended to assist fleets with their compliance efforts, it does not alter or modify the terms of any ARB regulation, nor does it constitute legal advice. It is the sole responsibility of fleets to ensure compliance with the In-Use Off-Road Diesel-Fueled Fleets Regulation.*

(BACT) requirements. If a fleet is electing to comply by meeting the fleet average requirements, there is no order in which vehicles must be turned over (e.g., a Tier 2 vehicle can be turned over before a Tier 0 vehicle). If the fleet is electing to comply by meeting the BACT requirements, the fleet must turn over its Tier 0 and Tier 1 vehicles, except those in vehicles that qualify for an exemption from the BACT requirements, before BACT credit can be earned for turning over vehicles with Tier 2 and higher engines. In that case, the fleet can choose which Tier 0 and Tier 1 vehicles will comply first.

**Example:** Fleet L is a large fleet with 8,000 total max horsepower (hp), consisting of a mix of Tier 0, Tier 1, and Tier 2 vehicles. The fleet meets the fleet average requirement for the 2014 compliance date, but because the fleet does not yet meet the fleet average requirement for the following year, the fleet has a BACT requirement of 640 hp (8% of its total max hp) for the January 1, 2015 compliance date. The fleet has decided to replace with newer vehicles to meet their BACT requirement. The fleet must choose to turn over a minimum of 640 hp of their Tier 0 and/or Tier 1 vehicles to meet their BACT requirement.

**Q – How long will my Tier 2 engine be exempt from BACT requirements?**

A – All vehicles with a Tier 2 engine are exempt from BACT requirements through January 1, 2015 (i.e., the first turnover of or VDECS installations on Tier 2 or higher engines would be required between January 1, 2015 and December 31, 2015), provided that all Tier 0 and Tier 1 vehicles in the owner's fleet that do not qualify for an exemption under section 2449.1(b)(2) have been turned over. However, this only affects large fleets since medium and small fleets do not have emission performance requirements until January 1, 2017 and January 1, 2019, respectively. Additionally, a vehicle is exempt from BACT requirements if the vehicle is less than 10 years old from the date of manufacture. While most vehicles with Tier 2 engines were manufactured between 2001 and 2007, those over 750 hp may have been manufactured as late as 2010, which could make them exempt through 2020.

A small fleet with less than 500 total horsepower<sup>1</sup> may be able to keep Tier 2 engines in their fleet indefinitely. The fleet may choose to meet an optional compliance schedule, which would allow the fleet to comply by phasing out all of their Tier 0 and Tier 1 vehicles, and replacing them with Tier 2 or greater vehicles, as specified in section 2449(e), and shown below.

<sup>1</sup> To qualify for the optional compliance schedule, the fleet must be less than 500 total horsepower, including vehicles that would otherwise be exempt from the fleet size determination, such as those designated as low-use, 51%-99% agricultural use, dedicated snow-removal, awaiting sale, or used exclusively for emergency operations.

*While this document is intended to assist fleets with their compliance efforts, it does not alter or modify the terms of any ARB regulation, nor does it constitute legal advice. It is the sole responsibility of fleets to ensure compliance with the In-Use Off-Road Diesel-Fueled Fleets Regulation.*

**Optional Compliance Schedule for Fleets with 500 HP or Less**

Compliance Date: January 1 of Year	Percent of Fleet (by horsepower) Which Must Have a Tier 2 or Higher Engine
2019	25
2022	50
2026	75
2029	100

**Q – I'm in the market for a new off-road vehicle; can I buy one with a Tier 3 engine, or does it have to be Tier 4?**

A – Vehicle owners can purchase and add Tier 3 engine vehicles to their fleet at any time. However, since a Tier 4 engine has significantly lower oxides of nitrogen (NOx) emissions than a Tier 3 engine, it will have a more positive effect on the fleet's average emissions, which would make meeting the final fleet average target easier.

**Q – If I purchase a Tier 3 engine now, how long will the Off-Road Regulation allow my fleet to keep it?**

A – A fleet owner can have a Tier 3 engine in their fleet until turnover is needed to meet fleet average or BACT requirements, which will vary depending on the fleet's vehicle make-up. The final fleet average targets are equivalent to approximately an interim Tier 4 engine standard. This means it is possible for a fleet to be able to meet the final fleet average target with a mix of Tier 4 and Tier 3 vehicles.

**Q – If I buy a Tier 4 engine now, will I have to replace it in the future?**

A – No; the Off-Road Regulation exempts Tier 4 interim and Tier 4 final engines from BACT requirements.

**Q – If most of my fleet is Tier 4, can I also keep some older engines in my fleet?**

A – Yes; some older engines may be in each fleet as long as the fleet keeps their fleet average index equal to or less than their fleet average target, uses credit to meet the BACT requirements, or if the engines are exempt. For example, small fleets may install VDECS on older engines to comply with BACT, making the vehicles exempt from BACT for as long as the VDECS are installed, regardless of the Tier level of the engine. Additionally, vehicles with older engines that are operated less than 200 hours each year may stay in the fleet as low-use vehicles, since vehicles designated as year-by-year or permanent low-use are not required to meet emission performance standards.

*While this document is intended to assist fleets with their compliance efforts, it does not alter or modify the terms of any ARB regulation, nor does it constitute legal advice. It is the sole responsibility of fleets to ensure compliance with the In-Use Off-Road Diesel-Fueled Fleets Regulation.*

**Q – Will all of my vehicles have to eventually be Tier 4?**

A – Not necessarily; as stated above, the final fleet average targets are equivalent to approximately an interim Tier 4 engine standard. This means that it may be possible for a fleet to be able to meet the final target with a mix of Tier 4 and Tier 3 vehicles, or even older vehicles if designated as low-use or otherwise exempt from BACT requirements.

*While this document is intended to assist fleets with their compliance efforts, it does not alter or modify the terms of any ARB regulation, nor does it constitute legal advice. It is the sole responsibility of fleets to ensure compliance with the In-Use Off-Road Diesel-Fueled Fleets Regulation.*

## Greenhouse Gas Emission Factors: Guidance for PG&E Customers November 2015

This document is intended to help Pacific Gas and Electric Company (PG&E) customers understand the different greenhouse gas (GHG) emission factors they may use to estimate GHG emissions. GHG estimates are often used for climate action planning purposes and voluntary GHG emissions tracking or reporting.

**PG&E's most recent electricity GHG emissions factor is for calendar year 2013.** It can be found [here](#). Due to the multiple sources of power used in the course of a year and the rigorous process PG&E follows to have its emissions independently verified by a third party, the emission factor for delivered electricity lags by over a year.

Please note: The information in this document is not to be used for mandatory GHG reporting, financial analysis, or regulatory compliance, and does not necessarily reflect the approaches taken by PG&E for its own regulatory compliance purposes.

### What is a GHG emission factor?

A GHG emission factor<sup>1</sup> is a measure of the pounds of carbon dioxide (CO<sub>2</sub>) emitted per megawatt-hour of electricity or per therm of natural gas.

- **Electricity** generated from fossil fuels such as natural gas or coal emit CO<sub>2</sub>, while other sources of electricity such as hydropower, wind, solar, and nuclear power are considered to be carbon-free. The electricity that PG&E delivers to customers comes from a mix of these generation sources. PG&E's emission factor for delivered electricity incorporates the annual energy and associated emissions from each generation source for the given year. Variance in PG&E's mix of electricity sources largely account for changes in PG&E's GHG emission factor from year to year.
- The **natural gas** emission factor represents the amount of GHGs emitted per therm of natural gas combusted. This emission factor does not vary because the composition of PG&E's natural gas does not change significantly over time.

### Electricity Emission Factors

If you are estimating the GHG emissions generated by a business, city, county, or related entity over the course of a year, and if 100% of your electricity was purchased from PG&E, you can use the average emission factor for all the PG&E electricity delivered during that specific year.

<sup>1</sup> An emission factor is also known as an emission rate or emission coefficient.

**Historic emissions:** Historic average emissions factors take into account all of the sources of electricity that PG&E delivered to customers during a specific year in the past. As a founding member of the California Climate Action Registry (CCAR), PG&E has emission factors that have been third-party verified starting in the year 2003. For factors prior to 2003, please see FAQ #2.

**Current/Future emissions:** Because of the multiple sources of power used in the course of a year and the rigorous process PG&E follows to have its emissions independently verified by a third party, the emission factor for delivered electricity lags by a year. To estimate GHG emissions in a recent or future year for which an emission factor is not yet available, we recommend using an average of the five most-recent coefficients available. Another resource is the emissions factor forecast for PG&E's electricity in the [CPUC GHG Calculator](#). The calculator is a publicly-available document that provides emission factor forecasts from 2014-2020 as shown below. Please note that the CPUC published the calculator in 2010 prior to the drought, so the forecasts do not take into consideration the impact of the drought on hydroelectric power.

**Avoided emissions:** When you implement an energy efficiency project or install a renewable generation project (e.g., a solar photovoltaic system), you are reducing your use of electricity from the utility, and therefore are avoiding the associated GHG emissions. Determining the emissions avoided from these projects can be complicated, depending on the season and time of day the electricity was saved.

For simplicity, you can use the relevant annual emission factor to estimate the GHGs avoided from these projects. See FAQ #5 for more information.



FOR INFORMATIONAL PURPOSES ONLY

**PG&E Emissions Factor Summary**

Emission Type	Emission Factor			Source
	Year	Lbs CO <sub>2</sub> / MWh	Metric tons CO <sub>2</sub> /MWh	
Historical Emissions	2003	620	0.281	PG&E's third-party-verified GHG inventory submitted to the California Climate Action Registry (CCAR) <sup>2</sup> (2003-2008) or The Climate Registry (TCR) (2009-2013)
	2004	566	0.257	
	2005	489	0.222	
	2006	456	0.207	
	2007	636	0.288	
	2008	641	0.291	
	2009	575	0.261	
	2010	445	0.202	
	2011	393	0.178	
	2012	445	0.202	
	<b>2013</b>	<b>427</b>	<b>0.194</b>	
2009-2013 Average	2009-2013	457	0.2074	Average of the last five years of historical emissions
CPUC Future Emissions (estimated in 2010 prior to the drought)	2014	412	0.187	CPUC GHG Calculator, which provides an independent forecast of PG&E's emission factors as part of a model on how the electricity sector would reduce emissions under AB 32 <sup>3</sup>
	2015	391	0.177	
	2016	370	0.168	
	2017	349	0.158	
	2018	328	0.149	
	2019	307	0.139	
	2020	290	0.131	

**Natural Gas Emission Factors**

Historic, Current, and/or Future: The combustion of natural gas (in your stove, a furnace, or a natural gas power plant) releases CO<sub>2</sub>. The emission factor for natural gas represents the amount of GHGs emitted per therm of natural gas combusted. Since the composition of PG&E natural gas does not change significantly over time, this factor does not change from year to year.

Emission Type	Year	Emission Factor		Source
		Lbs CO <sub>2</sub> /therm	Metric ton CO <sub>2</sub> /therm	
Historic, Current, or Future	All years	11.7	0.00531	U.S. Energy Information Administration <sup>4</sup>

<sup>2</sup> The 2003-2008 factors are in the Power/Utility Protocol (PUP) spreadsheet of PG&E's [CCAR reports](#). The 2009-2013 factors are in the Additional Optional Information tab of the Electric Power Sector (EPS) Report spreadsheet of PG&E's [TCR reports](#).

<sup>3</sup> E3, [GHG Calculator version 3c](#), worksheet tab "CO<sub>2</sub> Allocations," cells AH35 - AH44.

<sup>4</sup> U.S. Energy Information Administration, [Voluntary Reporting of Greenhouse Gases Program](#).

FOR INFORMATIONAL PURPOSES ONLY

**UPDATES:** The emissions factors will be updated annually, so please check with your PG&E account manager or the PG&E website at [www.pge.com/environment](http://www.pge.com/environment) for the most recent version.

**Frequently Asked Questions:**

1. Why do the emission factors for PG&E electricity vary from year to year?..... 4
2. Does PG&E have emission factors from years prior to 2003?..... 5
3. What emission factor should I use to calculate the emissions from electricity use in 1990?..... 5
4. Why do you use an average emission factor to estimate avoided emissions and not a marginal or project-specific emission factor?..... 5
5. What emission factor should I use if I want to estimate the emissions avoided through participation in PG&E's demand response programs?..... 5
6. If I am a direct access electricity customer, what emission factor should I use?.... 6
7. Can PG&E customers use the U.S. EPA carbon calculator to calculate the emissions from PG&E electricity?..... 6
8. What is the difference between the emission factors used in the U.S. EPA's Portfolio Manager benchmarking tool and PG&E's emission factors?..... 6
9. Does PG&E have emission factors for smaller geographic areas like cities or counties within its service territory?..... 6
10. Why are PG&E's emission factors in CO<sub>2</sub> and not CO<sub>2</sub>e (i.e. CO<sub>2</sub> equivalent)?..... 7
11. Why don't PG&E's emission factors include the emissions associated with the delivery of electricity or natural gas?..... 7
12. Who can I contact at PG&E to ask questions about emission factors?..... 7

1. Q: Why do the emission factors for PG&E electricity vary from year to year?  
A: PG&E's electricity emission factors vary primarily because the amount of available hydroelectricity varies from year to year. During drought years, less hydroelectricity is available and other power sources (usually natural gas generation) are used instead.

Emission factors also change, but less significantly, based on variables such as change in demand due to weather (hot summers mean more air conditioning demand). Increased demand on a short-term basis is generally met by fossil fuel generation, which raises the average emission factor. PG&E works to mitigate demand by following California's "loading order," which involves reducing electricity demand by increasing energy efficiency and demand response, and meeting new long-term generation needs first with renewable and distributed generation resources, and second with clean fossil-fueled generation. The loading order was adopted in the 2003 Energy Action Plan prepared by the California energy agencies<sup>5</sup>.

<sup>5</sup> [Implementing California's Loading Order for Electricity Resources](#).

FOR INFORMATIONAL PURPOSES ONLY

Over time, PG&E's emission factor is also decreasing as we make steady progress toward California's target of 33% renewables by the end of 2020.

2. Q: Does PG&E have emission factors from years prior to 2003?  
A: PG&E was among the earliest companies to voluntarily quantify and report its GHG emissions using rigorous, publicly-vetted GHG reporting standards. As a charter member of the California Climate Action Registry which later grew into The Climate Registry, PG&E has voluntarily registered and publicly reported its third-party verified GHG inventory every year since 2003. Prior to 2003, there were no commonly-accepted guidelines to report the GHG emission factors from a utility. If you would like to calculate emissions prior to 2003, you can use the 1990 emission factor in FAQ #3 below.
3. Q: What emission factor should I use to calculate the emissions from electricity use in 1990?  
A: You can use the factor from a study published by Lawrence Berkeley National Laboratory, which cites an emission factor of 0.070 kg C/kWh for PG&E in 1990.<sup>6</sup> This figure translates to approximately 572 lbs CO<sub>2</sub>/MWh or 0.259 metric tons CO<sub>2</sub>/MWh.<sup>7</sup>
4. Q: Why do you use an average emission factor to estimate avoided emissions and not a marginal<sup>8</sup> or project-specific emission factor?  
A: For the purposes of climate action planning or voluntary tracking and reporting, using an average emission factor simplifies the emissions calculation process. While some large entities may be required to estimate the amount of GHGs avoided by using emission factors specific to the hours of the day, the days of the year, or the seasons in which the energy use was avoided, the use of an average emission factor is appropriate for most customers.
5. Q: What emission factor should I use if I want to estimate the emissions avoided through participation in PG&E's demand response programs?<sup>9</sup>  
A: For the purposes of climate action planning or voluntary tracking or reporting, an average emission factor is appropriate. If you are participating in a third-party Demand Response program, you may reach out to your program manager for further guidance. Using the average factor is a simplification and may not

<sup>6</sup> LBNL-49945, Marnay *et al.*, Estimating the CO<sub>2</sub> emissions factors for the California Electric Power Sector, August 2002.

<sup>7</sup> Assuming 1 kg CO<sub>2</sub> = 0.27 kg C and 2.2046 lbs/kg.

<sup>8</sup> A marginal emission factor represents the emissions from electricity generated "at the margin", i.e., electricity generated in response to an additional unit of electricity demand. In California, this factor is typically that of a natural gas power plant, because this type of plant is most frequently deployed when electricity demand increases in the state. The California Air Resources Board (ARB) uses a marginal emission factor for California of 944 lbs CO<sub>2</sub>e/MWh. See: ARB, Mandatory Reporting Requirement Final Regulation, Section 95111(b)(1).

<sup>9</sup> PG&E's demand response programs offer incentives to customers that volunteer and participate by temporarily reducing their electricity use when demand could outpace supply.

FOR INFORMATIONAL PURPOSES ONLY

reflect the approach taken by large entities for regulatory compliance purposes.

6. Q: If I am a direct access electricity customer, what emission factor should I use?  
A: If you are a direct access customer, you should contact your direct access electricity provider for the appropriate emission factor. If the emission factor is unavailable, The Climate Registry's Local Government Operations Protocol and the World Resources Institute's GHG Protocol recommend using the EPA Emissions & Generation Resource Integrated Database (eGRID) annual output emission factors for the WECC California (CAMX) sub-region.
7. Q: Can PG&E customers use the U.S. EPA carbon calculator to calculate the emissions from PG&E electricity?  
A: PG&E does not recommend that customers use this calculator. The EPA calculator uses an average emission factor for electricity generated nationwide. PG&E's emission factor is independently verified and based on the PG&E-specific mix of electricity delivered to PG&E customers. Because of PG&E's higher use of lower- and zero-emission generation sources, PG&E's emission factor is more than 60 percent cleaner than the national average.<sup>10</sup> Using the EPA carbon calculator would dramatically overstate PG&E customers' emissions and any emissions savings associated with energy efficiency projects.
8. Q: What is the difference between the emission factors used in the U.S. EPA's Portfolio Manager benchmarking tool and PG&E's emission factors?  
A: The EPA tool uses emission factors from the EPA Emissions & Generation Resource Integrated Database (eGRID), which are derived from utility data for each of the 26 sub-regions of the U.S. power grid. Users are not able to enter a PG&E-specific emission factor into the tool. Instead, based on the zip code of each building entered, Portfolio Manager identifies the appropriate sub-region and emission factor, and provides a graphic comparison of the sub-region's emission factor and electric generation fuel mix to the national factor. PG&E customers are in the WECC<sup>11</sup> California (CAMX) sub-region. Because eGRID's WECC California emission factor has consistently been higher than PG&E's historic emission factors, customers should understand that this tool overestimates emissions from buildings that use PG&E electricity.

The tool also gives users the choice of selecting a specific power generation facility, which is not generally appropriate for the purposes of climate action planning or voluntary tracking and reporting, since the electricity delivered by PG&E to customers comes from a variety of sources.

9. Q: Does PG&E have emission factors for smaller geographic areas like cities or counties within its service territory?

<sup>10</sup> PG&E website: <http://www.pge.com/myhome/environment/pge/cleanenergy/index.shtml>.

<sup>11</sup> The Western Energy Coordinating Council (WECC) is a regional organization that promotes reliable electric service by establishing operating criteria and facilitating electric system support between utilities.

FOR INFORMATIONAL PURPOSES ONLY

A: No, PG&E's emission factor is based on the electricity delivered to all of its customers. Because electricity enters PG&E's electrical transmission and distribution system from multiple sources and gets distributed throughout the system to customers, it is not possible to calculate emission factors for specific geographic areas.

•

10. Q: Why are PG&E's emission factors in CO<sub>2</sub> (carbon dioxide) and not CO<sub>2</sub>e (i.e. CO<sub>2</sub> equivalent)?<sup>12</sup>

A: The electricity emission factors reported via CCAR and TCR are in pounds of CO<sub>2</sub> and not CO<sub>2</sub>e because their methodology for calculating emission factors only includes CO<sub>2</sub> and not methane (CH<sub>4</sub>) or nitrous oxide (N<sub>2</sub>O) from electricity generation. CCAR and TCR do not include CH<sub>4</sub> or N<sub>2</sub>O because these emissions are considered to be *de minimis*.

However, PG&E customers can still estimate the CH<sub>4</sub> and N<sub>2</sub>O emissions associated with their electricity use by using the California-specific emission factors provided by The Climate Registry's [Local Government Operations Protocol](#)<sup>13</sup>. For natural gas, customers can use the relevant default emission factors for natural gas provided by the same protocol<sup>14</sup>.

11. Q: Why don't PG&E's emission factors include the emissions associated with the delivery of electricity or natural gas?

A: The emissions associated with the delivery of electricity or natural gas are not included in PG&E's emission factors for delivered electricity or natural gas because those emissions are reported separately by PG&E in its own GHG inventory. Standard voluntary reporting practice is to report such emissions, like the emissions associated with transmission and distribution line losses, natural gas compressor stations, and vehicles used to service electricity and natural gas delivery systems, separately from the emissions attributed to the generation or use of the energy itself.

12. Q: Who can I contact at PG&E to ask questions about emission factors?

A: Email [ghgdatarequests@pge.com](mailto:ghgdatarequests@pge.com) and a PG&E employee will get back to you shortly.

<sup>12</sup> CO<sub>2</sub>e or CO<sub>2</sub> equivalent is a measure used to compare the emissions from various GHGs based upon their global warming potential (GWP). The CO<sub>2</sub>e for a gas is derived by multiplying the amount of the gas by the GWP of the gas.

<sup>13</sup> Version 1.1, May 2010. Page 209, Table G.7: California Grid Average Electricity Emission Factors (1990-2007).

<sup>14</sup> Page 205, Table G.3: Default Methane and Nitrous Oxide Emission Factors by Fuel Type and Sector.

# **Appendix R**

## Star-Tulip Record

## Oakland Star Tulip Records - Oak Knoll Project

<b>Observer</b>	<b>Qualifications</b>	<b>Number of Records</b>
BioBlitz volunteers	Unknown	1
Bree Candiloro	Stewardship Specialist Elkhorn Slough National Estuarine Research Reserve	1
Chris Jaster	Unknown	1
Cinda MacKinnon	Independent Environmental Scientist	1
Cynthia Powell	Calflora Executive Director	1
Danny Slakey	Former CNPS Staff Botanist	1
David Greenberger	Independent Botanist	4
Douglas Johnson	Cal-IPC Executive Director	1
Jeff Greenhouse	Jepson Herbarium Research Associate	10
Karen Paulsell	Friends of Sausal Creek Nursery Volunteer	1
Lamorna Brown Swigart	Unknown	1
pamela beitz	EBRPD Park Ranger	1
Patti Patterson	Board Member for California Lichen Society	1
Rachel Kesel	Yerba Buena CNPS Board Member	6
Richard Chasey	SFSU Graduate Student in Resource Management	3
Ryan O'Dell	BLM Botanist/Natural Resources Specialist	2
staff	Unknown	1
Teri Lim	Unknown	1
Tony Kendrew	Unknown	2

WRA, 2016

**Appendix S**  
Purple Needlegrass:  
Existing Distribution on  
the Project Site

Oak Knoll Mixed Use Community Development  
Alameda County, California

Figure 2.  
Overall Site Plan



Native Purple Needlegrass  
Planted Purple Needlegrass



Not to Scale

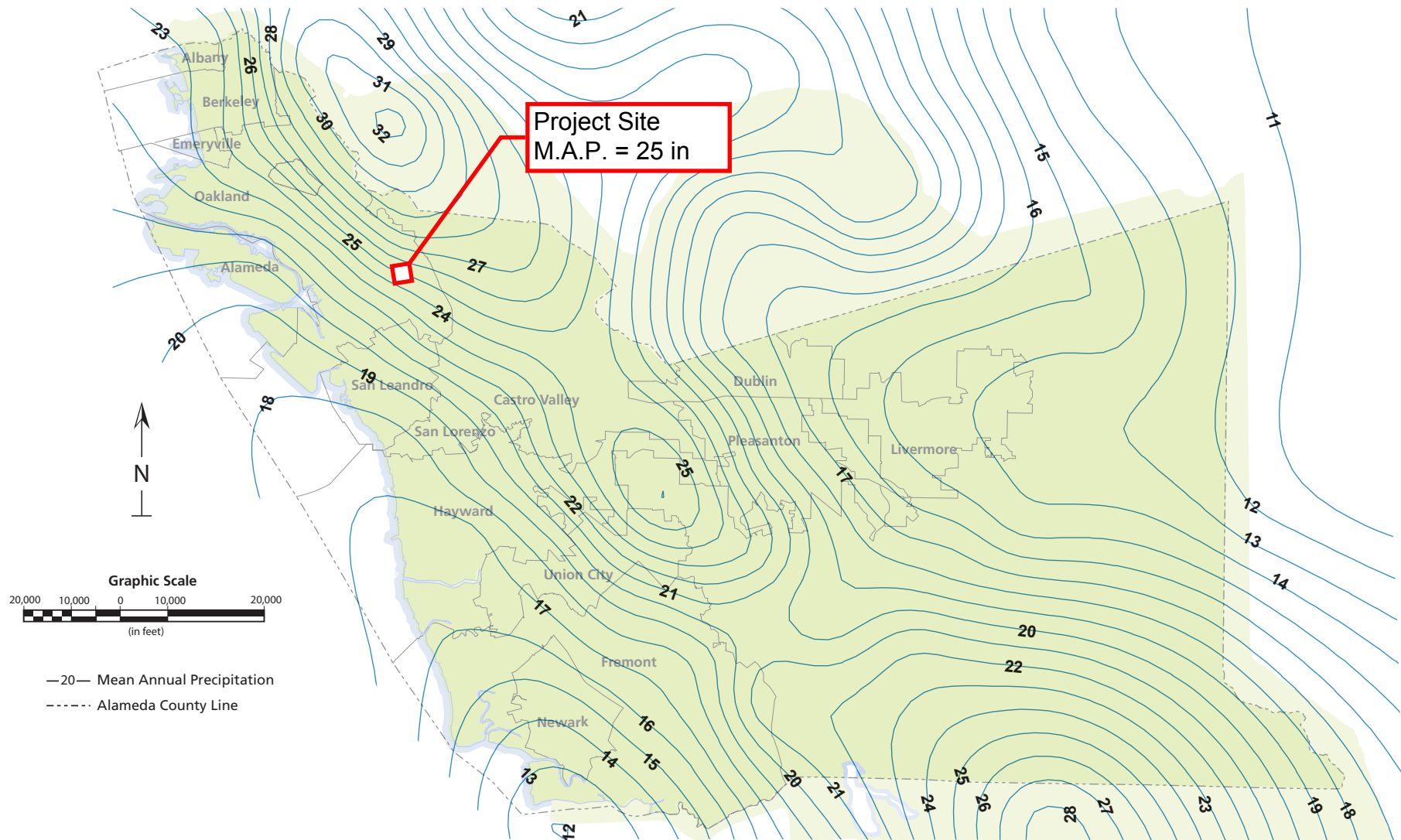
Map Prepared Date: 3/8/2017  
Map Prepared By: czumwalt  
Base Source:  
Data Source(s):

5 min. Walk

# **Appendix T**

## Mean Annual Precipitation Data





Attachment 6 available for download as a GIS file from the Alameda County Flood Control District website.

(District 2011)



Alameda County Hydrology & Hydraulics Manual 2016

# Mean Annual Precipitation

Attachment 6

**Appendix U**  
Oakland Police Department  
2016 Strategic Plan



Oakland Police Department  
Strategic Plan 2016

---

## Contents

INTRODUCTION.....	4
Values.....	5
Mission.....	5
Vision.....	5
Goals .....	5
Crime in Oakland.....	6
The Oakland Police Department: Limited Resources .....	6
Twenty-First Century Policing .....	6
Measure Z .....	6
Strategic Planning Defined.....	6
Previous Efforts.....	7
GOAL 1: REDUCE CRIME.....	8
Performance Measures for Reducing Crime.....	8
Objectives and Strategies for Reducing Crime.....	8
Reducing Crime: No Additional Resources .....	8
Reducing Crime: Additional Resources .....	11
GOAL 2: STRENGTHEN COMMUNITY TRUST AND RELATIONSHIPS .....	15
21 <sup>st</sup> Century Policing: Strengthening Community Trust and Relationships .....	15
Building Public Trust and Legitimacy .....	15
Policy and Oversight.....	16
Technology and Social Media .....	18
Community Policing and Crime Prevention .....	18
Performance Measures for Strengthening Community Trust and Relationships.....	19
Objectives and Strategies for Strengthening Community Trust and Relationships.....	19

Strengthening Community Trust and Relationships: No Additional Resources .....	20
GOAL 3: ACHIEVE ORGANIZATIONAL EXCELLENCE .....	23
21 <sup>st</sup> Century Policing: Achieving Organizational Excellence .....	23
Training and Education .....	23
Officer Wellness and Safety .....	24
Performance Measures for Achieving Organizational Excellence .....	24
Objectives and Strategies for Achieving Organizational Excellence .....	25
Achieving Organizational Excellence: No Additional Resources.....	25
Achieving Organizational Excellence: Additional Resources .....	27
Appendix I: Reports and Recommendations Concerning the Oakland Police Department .....	29
District-Based Investigations in Oakland .....	29
Best Practices Review: Oakland .....	30
Addressing Crime in Oakland: Zeroing Out Crime .....	33
Appendix II: The 2016 Oakland Police Department Strategic Planning Process.....	36
Appendix III: Objectives, Strategies, Timelines, and Position Responsible.....	40

## INTRODUCTION

December 28, 2015

Over the last several years, we have seen reduction of crime in critical categories. This reduction is due to the diligent work of the community, city staff, law enforcement partners, and Oakland Police Department personnel. I am grateful for all the efforts to date. Despite the reduction of crime in some key categories, there remains a great amount of work to be done. Any day there is a homicide, victim assaulted, home burglarized, child harmed, or other crime - means there is a victim and a community all suffering loss. Unfortunately, this is a loss felt all too often in our communities. With a renewed focus and intensity, we can and will do better. This plan lays out the efforts to achieve a 30 percent reduction in violent crime over three years. This is an achievable goal.

OPD continues to move toward the vision of the President's 21<sup>st</sup> Century Policing Task Force and continues to employ the highest standards of accountability. Recent innovations in police legitimacy are promising and have been shown to increase voluntary compliance with the law. Most notably, OPD became nationally recognized for the implementation of a procedural justice training program focused on four tenets: voice, neutrality, respect, and trustworthiness. Although research on the practice of procedural justice is still young, the tenets inform key practices in Oakland. For example, the Crisis Intervention Training Program prepares officers to respond in a way to stabilize and de-escalate situations involving individuals in crisis. This is key to improve our service to one of our most vulnerable and underserved populations. The Ceasefire Program communicates in a direct and respectful way to individuals most likely to be engaged in gun violence or injured by gun violence. This new type of relationship is critical as we rightfully focus efforts on the preventative side of gun violence. OPD is intentionally focusing on internal procedural justice to ensure all personnel feel respected, valued, and honored for their efforts. The Wellness Unit is being implemented and focuses exclusively on increasing the health and wellness of staff.

By April 2016, Professor Eberhardt, of Stanford's SPARQ (Social Psychological Answers to Real-world Questions) will release an introspective look into the Department's stop data records, documents, and community interactions. The Oakland community is looking forward to receiving the results, because this analysis is key to transparency and will inform OPD efforts to build police legitimacy. With a guardian mindset and humble approach, we will continue to critically evaluate our efforts and implement strategies to institutionalize fair and equitable policing practices. No program, policy, strategy, or policing practice is off limits to adjustment or outright abandonment if it erodes trust. These conversations will be challenging, but this learning organization is ready – Oakland deserves no less.

I want to thank all those involved in the completion of this strategic plan, particularly the Manager of OPD Research and Planning, who led this planning effort. This document is the result of a great deal of research, hard work, communication, and meticulous planning. The creation of this strategic plan resulted in the following Values, Mission, Vision, and Goals.

**Values**

The Oakland Police Department values:

*Fairness:* We promote accountability and transparency.

*Integrity:* We embrace honesty and professionalism.

*Respect:* We treat the community and each other with dignity.

*Service:* We serve the community with courage and honor.

*Teamwork:* We celebrate Oakland's diversity through partnerships.

**Mission**

The Oakland Police Department is committed to reducing crime and serving the community through fair, quality policing.

**Vision**

The vision of the Oakland Police Department is to be a leader in law enforcement through strong community partnerships, professionally developed employees, enhanced technology, and strategic and succession planning.

**Goals**

The goals of the Oakland Police Department are:

- Reduce Crime
- Strengthen Community Trust and Relationships
- Achieve Organizational Excellence

Sean C. Whent  
Chief of Police

## **Crime in Oakland**

Although progress has been made over the last several years, of the 50 largest American cities, Oakland tied Detroit and Memphis for the highest crime rate in 2014, with one Part I crime<sup>1</sup> for every 11 residents.<sup>2</sup> The nationwide average was one Part I crime for every 19 residents. Oakland had the third highest violent crime rate, with one violent crime for every 59 residents. The nationwide average was one violent crime for every 159 residents. Oakland had the highest robbery rate again in 2014, with one robbery for every 118 residents. The nationwide average was one robbery for every 520 residents.

***At 10 Part I violent crimes per officer, Oakland has more than any other large American city and more than twice the national average.***

## **The Oakland Police Department: Limited Resources**

In Oakland, the average number of residents per officer is 573. For the 50 largest American cities, the average number of residents per officer is 487.<sup>3</sup> In 2014, Oakland experienced 53 Part I crimes per officer (43 property crimes and 10 violent crimes). This was the highest in country and nearly twice the national average of 27.

## **Twenty-First Century Policing**

The United States is continuing to face a crisis of confidence in law enforcement. Two recent and significant events were police officers in Ferguson, Missouri and New York City used deadly force on unarmed African American males. These two incidents – coupled with a long history of disparate treatment of African Americans by law enforcement – served as a catalyst that resulted in formation of the President’s Task Force on 21<sup>st</sup> Century Policing. This strategic plan provides an opportunity to examine and incorporate task force recommendations and action items.

## **Measure Z**

In November 2014, the residents of Oakland passed Measure Z, the 2014 Oakland Public Safety and Services Violence Prevention Act. This measure funds a number of entities and programs, including several positions in OPD. Measure Z funds may be used only to pay for costs of the following objectives:

1. Reduce homicides, robberies, burglaries, and gun-related violence.
2. Improve police and fire emergency 911 response times and other police services.
3. Invest in violence intervention and prevention strategies that provide support for at-risk youth and young adults to interrupt the cycle of violence and recidivism.

## **Strategic Planning Defined**

Strategic planning is a disciplined effort to produce fundamental decisions and actions that shape and guide what an organization is, what it does, and why it does it.<sup>4</sup> Strategic planning is an attempt to answer three questions:

---

<sup>1</sup> Part I crime includes Murder, Rape, Robbery, and Aggravated Assault, Burglary, Motor Vehicle Theft, Larceny, and Arson.

<sup>2</sup> 2014 FBI Uniform Crime Reports: <https://www.fbi.gov/about-us/cjis/ucr/crime-in-the-u.s/2014/crime-in-the-u.s.-2014/cius-home>

<sup>3</sup> Ibid

<sup>4</sup> *Strategic Planning for Public and Nonprofit Organizations: A Guide to Strengthening and Sustaining Organizational Achievement* (3<sup>rd</sup> edition), page 6 by John M. Bryson



1. Where are we now?
2. Where do we want to be?
3. How are we going to get there?

### **Previous Efforts**

OPD published a strategic plan in August 2010. The plan included a mission statement, vision statement, values, and a motto. The plan included strategies (“priority actions”) to achieve objectives (“strategic objectives”). The plan included timeframes and strategies. The five goals (“vision”) in the 2010 plan were:

1. Oakland is one of the safest large cities in California – both in reality and perception
2. The Oakland Police Department provides high quality services in a Community-driven and customer-friendly manner
3. The Oakland Police Department is trusted, respected, and valued by those it serves
4. The Oakland Community and the Oakland Police Department work together to solve Community and neighborhood concerns and issues
5. The Oakland Police Department is an effective organization, providing a supportive and positive work environment for its employees

The 2010 OPD Strategic Plan included community perceptions of crime in Oakland and of OPD and comparisons to the other nine largest California cities in the following areas:

- Reported violent crime
- Average time required to answer calls to Communications
- Average response time for calls for service
- Number of calls for service
- Violent and property crime clearance rates and workload

The City of Oakland commissioned three studies in 2013 that focused on reducing crime. Information about these studies – including implementation efforts – is included as Appendix I:

- District-Based Investigations in Oakland: Rapid and Effective Response to Robberies, Burglaries and Shootings (May 2013, The Bratton Group, LLC)
- Best Practices Review: Oakland Police Department 2013 (October 2013, Strategic Policy Partnership, LLC)
- *Addressing Crime in Oakland: Zeroing Out Crime* (December 2013, Strategic Policy Partnership, LLC)

## GOAL 1: REDUCE CRIME

The City of Oakland continues to have one of the highest crime rates of any large American city. While many American cities have experienced significant reduction in crime – particularly violent crime – during the past decade, the City of Oakland has not followed this trend. Violent crime has increased in Oakland during the last ten years. In a 2014 article<sup>1</sup>, the City of Oakland was identified as the second most dangerous city in the United States. Similarly, in another 2014 news article<sup>2</sup>, the City of Oakland was identified as having the highest robbery rate in the country.

### Performance Measures for Reducing Crime

The primary performance measure for Goal 1: Reduce Crime is the Uniform Crime Report (UCR) published annually by the Federal Bureau of Investigation. While much debate has taken place as to the accuracy of the UCR – particularly with its identified limited ability to capture all crime committed – the UCR remains the most comprehensive capture of crime in the United States.

### Objectives and Strategies for Reducing Crime

In order to ensure implementation of this plan, it is scalable. Parallel objectives – and accompanying strategies – are provided for this goal in order to ensure that objectives are attainable with or without additional resources. The first set of objectives aligns with existing resources in OPD and guarantees that personnel will be challenged in working as efficiently as possible. The second set of objectives is based on the acquisition and implementation of identified additional resources. While it is hoped that this plan will serve as a means of acquiring additional resources, the desire of OPD to reduce crime transcends any such acquisition.

### Reducing Crime: No Additional Resources

**Objective: Reduce homicide by 30% over 36 months.**

**Objective: Reduce robbery by 30% over 36 months.**

**Objective: Reduce aggravated assault (including shootings) by 30% over 36 months.**

**Strategy:** Elicit greater assistance from community members through greater use of procedural justice, education/ training intervention related to implicit bias, external/ community information sharing, interaction at crime scenes and further engagement of the public in Ceasefire.

**Deadline:** July 1, 2016.      **Responsible:** See below.

- Procedural Justice Training: Personnel and Training Division Commander.

<sup>1</sup> 10 Most Dangerous Cities in America by Thomas C. Frohlich, Alexander Kent, & Alexander E.M. Hess, published online in the Huffington Post, 11/15/2014: [http://www.huffingtonpost.com/2014/11/15/most-dangerous-cities\\_n\\_6164864.html](http://www.huffingtonpost.com/2014/11/15/most-dangerous-cities_n_6164864.html)

<sup>2</sup> FBI report: Oakland again tops nation in robberies by Matthew Artz, published online in the Oakland Tribune, 11/16/2014: [http://www.mercurynews.com/breaking-news/ci\\_26944079/fbi-report-oakland-again-tops-nation-robberies](http://www.mercurynews.com/breaking-news/ci_26944079/fbi-report-oakland-again-tops-nation-robberies)

- Education/training intervention related to implicit bias: Personnel and Training Division Commander.
- External/community information sharing: Chief of Staff and Area Commanders.
- Interaction at crime scenes: CID Commander and Area Commanders.
- Further engagement of public in Ceasefire: Ceasefire Division Commander/ Area Commanders.

Like many jurisdictions in the United States, the City of Oakland faces challenges eliciting victim and witness cooperation in the investigation of violent crime such as homicide, robbery, and aggravated assault. As OPD leads the country in the adaptation and delivery of procedural justice training and practices, greater community assistance is expected. The Oakland Police Department continues to improve its transparency and share as much information as quickly as possible. One related strategy is to encourage OPD personnel to engage the public in discussion when protecting a crime scene. As curious community members ask about what has happened, officers have an opportunity to provide basic information and, in return, try to gather information from those onlookers who may have important information about the persons involved.

**Strategy:** Designate Patrol Officers to Assist the Criminal Investigation Division.

**Deadline:** July 1, 2016.      **Responsible:** Area Commanders.

Due to limited resources, CID is required to establish strong relationships with designated Bureau of Field Operations (BFO) personnel to assist with investigative tasks. These tasks include locating witnesses and evidence and other follow-up work. Formalizing a process or program to designate BFO personnel would greatly enhance the efficiency of the required interactions. Investigators would no longer be required to spend time trying to elicit cooperation on a day-to-day basis from field personnel. Additional benefits would include opportunities for Patrol Officers to better learn what is needed for investigation of homicide, robbery, and aggravated assault. This may be accomplished by assigning one officer per squad to check in with CID on a regular basis and share information. OPD presently uses Area Intelligence Officers to perform this function through weekly area reports, though such positions are not permanent within the organization. Further consideration of such positions – especially in light of the newly created Crime Analysis Section – would be worthwhile and should include weekly area reports.

**Strategy:** Implement Intelligence-Led Policing through Creation of a Crime Analysis Section.

**Deadline:** March 1, 2016      **Responsible:** Bureau of Investigations Deputy Chief.

The Oakland Police Department had four Administrative Analyst II positions budgeted to serve as crime analysts. These four positions had various assignments within OPD performing varying levels of crime analysis for different units. What OPD has lacked is the ability to perform crime and intelligence analysis effectively. The volume of crime requires several crime analysts just to process robbery reports for identification of patterns and trends. A centralized Crime Analysis Section with a minimum of five crime analysts is needed just to provide basic intelligence analysis for OPD. A Police Services Manager I is being hired to manage the section.

One way that the Crime Analysis Section can have significant positive impact on crime reduction is to provide Ceasefire with dedicated crime analysis capabilities. OPD has experienced great success through using the Ceasefire strategy to reduce violent crime. One critical component of this success is analysis of the social networks of involved parties. Expanding the social network analysis beyond those involved in homicides and aggravated assaults to individuals involved in robberies would assist CID in identifying and arresting robbery suspects. Additional Crime Analysts will be used for this purpose.

**Strategy:** Ensure Ceasefire strategy training Department-wide with a focus on those most involved.

**Deadline:** March 1, 2016      **Responsible:** Personnel and Training Division Commander.

OPD has made great strides in implementing Ceasefire through a recent limited reorganization. A significant number of staff (a lieutenant and several sergeants and officers) now report to the Ceasefire Commander. Shooting review, robbery review, and ongoing time-based crime reduction plans also embody the Ceasefire strategy.

As provided in the Best Practices Review, “[e]very officer in the Department must understand the underlying philosophy of the initiative and how they can impact its success.”<sup>1</sup> Ceasefire has sometimes been perceived as something special that only select members of OPD are chosen to participate in. Educating all OPD personnel in its philosophy and legitimacy is critical to its continued success.

**Strategy:** Implement gun tracing to identify, track, and connect illegal use of firearms.

**Deadline:** March 1, 2016      **Responsible:** Bureau of Investigations Deputy Chief.

The FY 2015-2017 Adopted Policy Budget allocates one million dollars (\$1M) over two years for special investigations to reduce gun violence and illegal gun dealing as a pilot program. To support these efforts, OPD will use an additional Police Records Specialist, two additional Crime Analysts, and operational overtime. OPD will also purchase three gun microscope cameras, a gun laser scanner and other technology to support gun database entry and automation. OPD’s current data entry process for gun tracing is cumbersome and OPD does not have staff to analyze data and develop useful intelligence.

**Strategy:** Make greater use of video in public areas.

**Deadline:** January 1, 2017      **Responsible:** Bureau of Services Deputy Chief  
Bureau of Investigations Deputy Chief

Efforts are being undertaken to allow residents and business owners in Oakland to register their video cameras with the Oakland Police Department. These cameras are of public areas – such as sidewalks, streets, and parking lots. This registration process will lead to OPD personnel being able to identify potential video captures of crimes, which should increase the identification

---

<sup>1</sup> *Best Practices Review: Oakland Police Department 2013* (October 2013, Strategic Policy Partnership, LLC): <http://www2.oaklandnet.com/oakca1/groups/police/documents/webcontent/oak045374.pdf>, p. 31

of suspects. This is critically important, as witnesses are often reluctant to come forth and assist the police. Even in those instances where eyewitness identification is available, video evidence provides an infallible means of identifying suspects.

While private video has greatly assisted OPD in solving cases and registration will further enhance, City of Oakland video would provide much greater results. The Best Practices Review provides this recommendation: “Significantly increase the camera monitoring capabilities of the OPD in commercial areas throughout the city to provide identifications and evidence in robbery, burglary, and some shooting cases.”<sup>1</sup> Politically, any discussion in the City of Oakland concerning greater use of video – particularly video monitoring controlled by the City – has met with great challenges. Considering the incredible difficulty in locating witnesses to violent crime, greater use of video of public areas may be worth pursuing. Other large American cities have seen dramatic reductions in violent crime through use of city-owned video systems.

An additional consideration is the encouragement, facilitation, and funding of Oakland residents and business owners in the installation and maintenance of video systems. In cooperation with the City – through a registration system – such a program could provide great benefits to all stakeholders in the process.

This strategy should be implemented with existing resources, as the technology costs should be minimal. Needed personnel should also be minimal, as the technology should automate most processes.

### **Reducing Crime: Additional Resources**

*The following objectives differ from the previous because they require additional resources.*

<p><b>Objective: Reduce homicide by 40% over 36 months.</b> <b>Objective: Reduce robbery by 40% over 36 months.</b> <b>Objective: Reduce aggravated assault (including shootings) by 40% over 36 months.</b></p>
--

<p><b>Strategy:</b> Add additional sworn and support positions.</p>
---

**Deadline:** TBD.

**Responsible:** TBD.

The Oakland Police Department dispatched 250,127 calls for service in 2014. Full staffing for Patrol is 256 officers. The result is an average of 977 calls per officer if OPD is at full staffing, which is an unusual occurrence. In practice, the average number of calls per officer per year is over 1,000. The sheer volume of calls has significant results when it comes to being able to effectively reduce violent crime:

- Officers are unable to respond to calls in a timely manner. This results in victims being unable to clearly recall information and lost opportunities to interview witnesses and apprehend suspects.

---

<sup>1</sup> *Best Practices Review: Oakland Police Department 2013* (October 2013, Strategic Policy Partnership, LLC): <http://www2.oaklandnet.com/oakca1/groups/police/documents/webcontent/oak045374.pdf>, Recommendation 17

- Officers are unable to spend adequate time investigating crime due to the need to respond to additional calls. This results in a loss of critical information for investigators to effectively perform follow up work.

By any measure, OPD is tremendously understaffed. As of late 2015, approved sworn staffing was 737 with a budgeted increase to 777 in July 2016. While the consequences of this are felt throughout the organization, it is exceptionally challenging in Patrol. The following recommendations are based on analysis of the 2014 FBI Uniform Crime Report data:<sup>1</sup>

- Based on population, OPD should have 842 sworn personnel
- Based on the violent crime rate, OPD should have 1,805 Officers

One way to essentially – and more effectively – add sworn personnel is to increase the number of civilian positions. There are a number of positions that are currently staffed by sworn personnel that would be better staffed by civilians. Examples of these positions include Fleet Management, Information Technology, and Public Information. Adding civilian positions to fulfill these roles would allow the redeployment of sworn personnel to more appropriate sworn roles while OPD benefits from the specialized skills and knowledge that come with career civilian positions. Civilian positions are less costly to the City than equivalent sworn positions.

**Resources:** A minimum of 65 additional sworn personnel (to reach 842). Based on mandated supervisory ratios, this should include at least nine Sergeants of Police. A Captain of Police and three Lieutenants of Police should also be included. Civilian positions and the number of each position (provided as FTE – Full Time Equivalent) include:

- Facility Manager (1 FTE)
- Fleet Manager (Administrative Analyst II – 1 FTE)
- Information Systems Supervisor (1 FTE)
- Police Communications Supervisor (4 FTE)
- Police Property Specialist (2 FTE)
- Public Information Officer II (1 FTE)
- System Analyst (3 FTE)

**Funding Sources:** General Purpose Fund appropriation is required for ongoing personnel costs.

<b>Strategy:</b> Create a Fugitive Apprehension Team.
---

**Deadline:** TBD.

**Responsible:** TBD.

The Oakland Police Department currently has two officers assigned to apprehend fugitives. In practice, these two officers merely pick up individuals who are already in custody with other agencies based on crimes committed in Oakland. Creating a Fugitive Apprehension Team would allow the arrest of individuals who have been identified as suspects in crimes but are not currently arrested due to the limited resources of OPD. Arresting such individuals and processing them further in the criminal justice system will reduce the opportunities for these individuals to commit additional crimes in Oakland.

<sup>1</sup> 2014 FBI Uniform Crime Reports: <https://www.fbi.gov/about-us/cjis/ucr/crime-in-the-u.s/2014/crime-in-the-u.s.-2014/cius-home>

**Resources:** One additional Sergeant of Police and six additional Police Officers.

**Funding Sources:** General Purpose Fund appropriation is required for ongoing personnel costs.

**Strategy:** Assign additional Homicide Investigators to CID.

In a report presented to the Oakland Public Safety Committee on May 12, 2015, an analysis of homicide caseloads resulted in a recommendation of four additional homicide investigators (from 12 to 16).

**Resources:** Two additional Sergeants of Police and two additional Police Officers and associated equipment in CID.

**Funding Sources:** General Purpose Fund appropriation is required for ongoing personnel costs.

**Strategy:** Assign Additional Robbery Investigators to CID for Patrol Areas.

**Deadline:** TBD.

**Responsible:** TBD.

At present, OPD has a very limited ability to respond to crimes that have just occurred. Because of the extraordinarily high call volume and very limited resources, Oakland Police preliminary investigations are insufficient, even for serious crimes such as robbery. The results are critical failures in three areas: an inability to gather information from victims when memory is strongest; an inability to interview witnesses before they have left the area; and an inability to apprehend robbery suspects before they flee. Dedicating sworn personnel to be able to respond immediately to robberies that have just occurred will greatly increase opportunities to obtain useful information from victims and witnesses as well as opportunities to arrest suspects.

In addition to being able to respond immediately to robberies, these officers would be able to perform necessary follow-up investigative work when not investigating a crime that just occurred. This follow-up investigative work would allow traditional CID Robbery Section Investigators to perform other investigative functions.

**Resources:** Five additional Sergeants of Police and 30 additional Police Officers and associated equipment in CID.

**Funding Sources:** General Purpose Fund appropriation is required for ongoing personnel costs.

**Objective:** Reduce property crime by 30% over 36 months.

**Strategy:** Expand biological evidence collection and processing to property crimes.

**Deadline:** TBD.

**Responsible:** TBD.

Expansion of the collection and processing of biological evidence and fingerprint evidence to all property crimes would greatly enhance the ability of OPD to solve these crimes. At present,

OPD does very little to collect or process evidence from property crimes. Research shows that 10 percent of all property crimes could yield DNA evidence, of which 77 percent should yield a searchable profile. Applying these rates to OPD should yield 1,078 case hits per year. In addition to field personnel (Police Evidence Technicians) to collect the evidence and crime lab personnel (Criminalist IIs) to process the evidence, additional Police Officers are needed to serve as property crime investigators by building cases and apprehending offenders based on the increase in collected and processed evidence. The size of the OPD Crime Lab would also have to be significantly expanded to house the additional personnel and work areas.

Fifty-six percent of all incidents that result in the collection of latent prints include computer searchable (AFIS) prints. If searched, the AFIS database is expected to return the source of the prints approximately 50 percent of the time. Based on the last four years of data, OPD receives approximately 500 AFIS quality cases per year. However, only 15 percent of these are searched and most of those are associated with person crimes. On average, 428 cases per year are not searched. Those cases represent 214 lost opportunities to solve crime annually. In order to search all the AFIS prints the lab currently receives, OPD estimates a need for two additional examiners. However, those two additional staff members cannot be accommodated in the current facility.

With true intelligence-led policing, it is much more cost effective to use available technology (and accompanying civilian personnel) than to simply assign more sworn investigators who will not be able to make informed decisions based on science.

**Resources:** Fifty Police Evidence Technicians, 35 Criminalist IIs, 10 Police Officers and an expanded Crime Lab.

**Funding Sources:** General Purpose Fund appropriation is required for ongoing personnel costs. Outside funding – including grants – may be available for the capital costs of expanding the Crime Lab.



## GOAL 2: STRENGTHEN COMMUNITY TRUST AND RELATIONSHIPS

Like many other diverse communities in the United States, Oakland has a history of tumultuous relations between the police and the community. This history includes the founding of the Black Panther Party in 1966, the Riders' scandal in 2000, and the Occupy movement of 2011. The Riders' scandal resulted in Federal monitoring of OPD.

### **21<sup>st</sup> Century Policing: Strengthening Community Trust and Relationships**

Strengthening Community Trust and Relationships requires OPD to act upon the first four of the six pillars (main topic areas) provided by the *Final Report of the President's Task Force on 21<sup>st</sup> Century Policing*. The first four pillars are:

- Building Trust and Legitimacy
- Policy and Oversight
- Technology and Social Media
- Community Policing and Crime Prevention

#### *Building Public Trust and Legitimacy*

Concerning the first pillar, the *21<sup>st</sup> Century Policing* report states: "People are more likely to obey the law when they believe that those who are enforcing it have the legitimate authority to tell them what to do...The public confers legitimacy only on those who they believe are acting in procedurally just ways."<sup>1</sup> Specific *Twenty-First Century Task Force* recommendations to build public trust and legitimacy include:

- Develop a guardian (rather than a warrior) mindset.
- Adopt procedural justice as the guiding principle for policies and practices.
- Acknowledge the role of policing in past and present injustice and discrimination.
- Develop a culture of transparency and accountability.
- Promote legitimacy internally by applying procedural justice principles.
- Initiate positive non-enforcement activities to engage communities with high rates of investigative and enforcement involvement.
- Consider potential damage to public trust when implementing crime fighting strategies.
- Track the level of trust in the police similar to changes in crime.
- Create a workforce diverse in race, gender, language, life experience, and cultural background.
- Build relationships with immigrant communities based on trust.

---

<sup>1</sup> *Final Report of the President's Task Force on 21<sup>st</sup> Century Policing*, (May 2015, Office of Community Oriented Policing Services, [http://www.cops.usdoj.gov/pdf/taskforce/taskforce\\_finalreport.pdf](http://www.cops.usdoj.gov/pdf/taskforce/taskforce_finalreport.pdf)), p. 1

Specific examples responsive to the *21<sup>st</sup> Century Task Force* recommendations to build public trust and legitimacy/community undertaken by OPD include:

- Providing California POST-certified Procedural Justice training to all sworn personnel. This helps ensure that officers give people a voice, fair treatment, and respect. The program was developed with and is taught with community members.
- Participating in the White House Open Data Initiative, an online portal that provides the public with information about practices of particular concern, including use of force.
- Dedicating OPD officers serve as mentors in high-risk middle schools. OPD also mentors African American males 12 to 18 years in the Our Kids (OK) program.
- Ensuring OPD's diversity resembles Oakland's and sharing this information monthly.

### *Policy and Oversight*

Concerning the second pillar, the *21<sup>st</sup> Century Policing* report states: "Citizens have a constitutional right to freedom of expression, including the right to peacefully demonstrate."<sup>1</sup> Specific *21<sup>st</sup> Century Task Force* recommendations concerning policy and oversight include:

- Collaborate with community members to develop strategies in communities disproportionately affected by crime for deploying resources by improving relationships, greater community engagement, and cooperation.
- Implement policies on the use of force that include training, investigations, prosecutions, data collection, and information sharing that are clear, concise, and publicly available.
- Implement non-punitive peer review of critical incidents separate from criminal and administrative investigations.
- Adopt identification procedures that implement scientifically supported practices that eliminate or minimize presenter bias or influence.
- Report and make available to the public census data regarding the composition of their departments including race, gender, age, and other relevant demographic data.
- Collect, maintain, and analyze demographic data on all detentions (stops, frisks, searches, summonses, and arrests) disaggregated by school and non-school contacts.
- Create policies and procedures for policing mass demonstrations that employ a continuum of managed tactical resources to minimize the appearance of a military operation and avoid provocative tactics and equipment that undermine civilian trust.
- Implement civilian oversight in order to strengthen trust with the community in a form and structure as defined by the community to meet their needs.
- Refrain from practices requiring officers to issue a determined number of tickets, citations, arrests, or summonses, or to initiate investigative contacts with citizens for reasons not directly related to improving public safety, such as generating revenue.
- Require officers to seek consent before a search and explain that a person has the right to refuse consent when there is no warrant or probable cause and ideally obtain written acknowledgement that they have sought consent to a search.
- Enact policies prohibiting profiling and discrimination based on race, ethnicity, national origin, age, gender, gender identity/expression, sexual orientation, immigration status, disability, housing status, occupation, and/or language fluency.
- Adopt policies requiring officers to provide their names to individuals they have stopped, along with the reason for the stop, the reason for a search if one is conducted, and a card with information on how to reach the civilian complaint review board.

---

<sup>1</sup> Ibid, p. 19

Specific examples responsive to the *21<sup>st</sup> Century Task Force* recommendations concerning policy and oversight undertaken by OPD include:

- Implementing a community advisory group in each of the five Patrol Areas to provide input on strategy to address community issues.
- Assigning a Community Resource Officer (CRO) to each of the 35 Police Beats to act as a liaison between the community and OPD/City resources.
- Using the Ceasefire strategy in communities disproportionately affected by crime to provide improved relationships, greater community engagement, and cooperation.
- Implementing progressive use of force policies and making them available online.
- Transitioning policies to the Lexipol system will result in better policies that are clearer and more concise.
- Implementing double-blind sequential photo line-ups in which the officer showing the photos is unaware of the identity of the suspect and witnesses are shown photos one at a time in order to eliminate or minimize presenter bias or influence.
- Presenting the Oakland City Council Public Safety Committee with a monthly staffing report that includes demographic data for staff including race, age, and residency. This report is published online.
- Publishing a Stop Data Report semi-annually online that provides demographic information on all discretionary stops. OPD has no enforcement presence on school campuses.
- Creating nationally-recognized policies, procedures, and practices for policing mass demonstrations that minimize the appearance of a military style operation and use only the force absolutely necessary. Military-type vehicles are not used for demonstrations absent information that would necessitate their use and officers do not wear helmets until the need for skirmish lines occurs.
- Implementing civilian oversight through the Citizen Police Review Board.
- Prohibiting a minimum number of citations or arrests and expecting very little revenue from citations. OPD stop data for 2014 shows the average field officer made about 75 stops, which is less than two per work week. Half of these stops resulted in the driver being released with only a verbal warning and no citation.
- Requiring officers to notify people of their right to refuse a consent search. OPD officers are equipped with body worn cameras which capture most consent search requests.
- Prohibiting profiling and discrimination by policy and practice based on race, ethnicity, national origin, age, gender, gender identity/expression, sexual orientation, immigration status, disability, housing status, occupation, and/or language fluency.
- Requiring officers to provide their names to individuals they have stopped upon request. OPD also has issued business cards to facilitate this process that have complaint information on them. This plan will implement a practice of officers issuing business cards with officer names for every investigative consensual encounter or detention.

### *Technology and Social Media*

Concerning the third pillar, the *21<sup>st</sup> Century Policing* report states: “Implementing new technologies can give police departments an opportunity to fully engage and educate communities in a dialogue about their expectations for transparency, accountability, and privacy.”<sup>1</sup> Specific *21<sup>st</sup> Century Task Force* recommendations concerning technology and social media include:

- Design the implementation of appropriate technology by law enforcement agencies to consider local needs and align with national standards.
- Update public record laws.
- Adopt model policies and best practices for technology-based community engagement that increases community trust and access.

Though faced with continuing technology concerns in terms of systems support and reliable infrastructure, OPD has led the nation in the implementation of new technologies such as body-worn cameras. Specific examples responsive to the *21<sup>st</sup> Century Task Force* recommendations concerning technology and social media undertaken by OPD include considering community trust when composing technology and other policies. OPD policies – particularly technology policies – are considered progressive. Public record laws do need to be updated to consider rapidly developing technologies such as video from body worn cameras and address associated privacy issues.

### *Community Policing and Crime Prevention*

Concerning the fourth pillar, the *21<sup>st</sup> Century Policing* report states: “Community policing requires the active building of positive relationships with members of the community.”<sup>2</sup> Specific *21<sup>st</sup> Century Task Force* recommendations concerning community policing and crime prevention include:

- Develop and adopt policies and strategies that reinforce the importance of community engagement in managing public safety.
- Infuse community policing throughout the culture and organizational structure of law enforcement agencies.
- Engage in multidisciplinary, community team approaches for planning, implementing, and responding to crisis situations with complex causal factors.
- Encourage communities to support a culture and practice of policing that reflects the values of protection and promotion of the dignity of all, especially the most vulnerable.
- Work with neighborhood residents to coproduce public safety by working with community residents to identify problems and collaborate on implementing solutions that produce meaningful results for the community.
- Encourage communities to adopt policies and programs that address the needs of children and youth most at risk for crime or violence and reduce aggressive law enforcement tactics that stigmatize youth and marginalize their participation in schools and communities.

---

<sup>1</sup> *Final Report of the President’s Task Force on 21<sup>st</sup> Century Policing*, (May 2015, Office of Community Oriented Policing Services, [http://www.cops.usdoj.gov/pdf/taskforce/taskforce\\_finalreport.pdf](http://www.cops.usdoj.gov/pdf/taskforce/taskforce_finalreport.pdf)), p. 31

<sup>2</sup> *Ibid*, p. 41

Specific examples responsive to the *21<sup>st</sup> Century Task Force* recommendations concerning policy and oversight undertaken by OPD include:

- Creating a policy on community policing that emphasizes community engagement.
- Designating the improvement of police community relations as one of the top priorities of the organization and one of three goals in this plan.
- Implementing geographic command based on a community policing principle that better engagement with the community will provide greater crime reduction.
- Recognizing that crime is a symptom of a much larger social and economic issue and works with other government and non-government resources to be a part of a holistic community safety plan.
- Mandating officers to attend at least one community meeting per quarter. In addition to that the Department is using social media to reach out to larger segments of the community.
- Piloting an alternative community meeting model where officers attend smaller neighborhood meetings in a resident's home where a meal is served. This is more intimate than traditional community meetings.
- Encouraging officers to walk in neighborhoods as much as time permits.
- Partnering with Neighborhood Crime Prevention Councils and required all Patrol Area Captains to work with an advisory committee made up of residents for this purpose.
- Prohibiting personnel from participating in the school disciplinary process. OPD presence on school campuses is entirely in a mentoring mode unless responding to urgent calls for service. OPD also participates in restorative justice programs for youth offenders.
- Creating a Youth Advisory Committee based on Youth Commission recommendations.
- Implementing comprehensive PAL and OK Mentoring programs.
- Assigning officers as mentors in six middle schools.

OPD has improved relations with the Oakland community through implementation of Procedural Justice, Neighborhood Services, and Federally-mandated reforms. Much work has yet to be done, as residents of the city's poorest communities still have memories and stories from generations of poor treatment by members of OPD.

### **Performance Measures for Strengthening Community Trust and Relationships**

The primary performance measure for strengthening community trust and relationships are community surveys. The most recent (2013-14) community survey conducted by OPD found that, of 2,426 respondents, 23 percent were very satisfied or satisfied with the level of dedication to community policing and 44 percent were dissatisfied or very dissatisfied. In the same survey, 66 percent of 2,335 respondents indicated they trusted OPD and 34 percent indicated that they did not. Eighty-five percent of 1,200 respondents indicated that they were treated in a fair and impartial manner by Oakland Police officers and 15 percent indicated that they were not. Finally, 67 percent of 1,072 respondents indicated that the Oakland Police officer (with whom they interacted) explained the officer's actions and the law, while 33 percent indicated that the officer did not. A new survey will be conducted in 2016.

### **Objectives and Strategies for Strengthening Community Trust and Relationships**

The first set of objectives is achievable without additional resources. The second set of objectives requires additional resources.

## **Strengthening Community Trust and Relationships: No Additional Resources**

**Objective: Increase Community Satisfaction by 15% over 36 Months.**

**Strategy:** Establish an Officer Involved Shooting (OIS) / In-custody death protocol to include the release of body-worn camera video.

**Deadline:** July 1, 2016.      **Responsible:** Chief of Police.

The advent of body worn cameras has provided law enforcement with an opportunity to truly show the public what an officer experiences, particularly when force is used. Releasing body worn camera video can provide a layer of transparency unparalleled in policing. Releasing this video as early as possible without compromising any of the many necessary administrative, investigative, and legal processes will be of great value to all stakeholders.

**Strategy:** Implement neighborhood outreach within 24 hours of SWAT operations and specific search warrants.

**Deadline:** March 1, 2016.      **Responsible:** Patrol Area Commanders.

OPD conducts targeted crime reduction operations such as SWAT operations and service of specific search warrants. Failure to notify residents of the purpose of the mission can make residents feel that they are being subjected to an occupying force. While notifying residents prior to the operation cannot be done due to concerns about safety and effectiveness, providing information about the operation upon completion or within a short time following the operation should bring a greater understanding of the role of OPD in reducing crime through targeted efforts.

**Strategy:** Better explain homicide and shooting investigation processes to the public through advanced procedural justice training for OPD Personnel.

**Deadline:** July 1, 2016.      **Responsible:** Ceasefire Division.

Homicide and (other) shooting investigations take place in Oakland frequently. Unfortunately, community members are not necessarily informed of the processes required for these investigations. This results in frustration for community members, who feel shut out from significant events in their own neighborhoods. Explaining the investigation process – without disclosing sensitive information – may assist community members in feeling connected to the process and lead to higher clearance rates. An action as simple as explaining to a community member what happened at the edge of a crime scene (the tape line) would provide valuable community support for OPD and may even yield valuable investigative information.

**Strategy:** Respond to, implement, and manage the recommendations of the Stanford University Report on Stop Data.

**Deadline:** August 1, 2016.      **Responsible:** Assistant Chief of Police.

Stanford University – through the work of Professor Jennifer Eberhardt and SPARQ – is performing groundbreaking analysis of OPD Stop Data. Stop Data is the information collected by the Department concerning race and gender of members of the public who are contacted by OPD in discretionary stops – such as traffic stops.

**Strategy:** Implement living room meetings with residents.

**Deadline:** July 1, 2016.      **Responsible:** Patrol Area Commanders.

Community meetings are regarded as a key element in engaging community members in a dialog with local police. Such meetings are held in a variety of settings, with attendance and efficacy sometimes challenged by location. In the last few years, law enforcement organizations have achieved success in smaller, less formal settings than a community center or other public forum.

**Strategy:** Increase the number of Foot Patrol Officers from three to 18.

**Deadline:** July 1, 2016.      **Responsible:** Chief of Police.

Several studies in the last few decades have demonstrated the effectiveness of foot patrol in increasing community engagement and satisfaction with local police. Such studies have also shown decreases in crime. OPD has accepted grant funding from the United States Department of Justice/Office of Community Oriented Policing Services (USDOJ/COPS) to partially fund 15 additional foot patrol officers. Matching funding has been identified by the City of Oakland Budget Office. The grant provides that additional foot patrol officers be assigned to high crime areas in long-term assignments. This should provide for building community trust and relationships while reducing crime.

**Strategy:** Protect homicide victims from public view at crime scenes.

**Deadline:** July 1, 2016      **Responsible:** Criminal Investigations Division Commander.

Homicide investigations often require leaving a victim in place for hours. This is largely due to California law, which prohibits the movement of a deceased person by an ambulance and requires movement by a coroner. While necessary, leaving a deceased person in place for a long time can be perceived as being disrespectful by community members, particularly those who have long-standing mistrust of police. Implementing a protocol that protects homicide victims from public view during an investigation should provide an opportunity for greater respect and understanding of OPD from community members.

**Strategy:** Recognize and reward staff who volunteer their time for community service.

**Deadline:** July 1, 2016.      **Responsible:** Personnel and Training Division Commander.

One way to demonstrate that OPD is a service provider – and not just a law enforcement organization – is to encourage OPD staff to volunteer in the Oakland community. While it would be challenging to require paid staff to devote time to volunteering, such efforts can be recognized and rewarded. OPD can implement a system that tracks hours and provides awards when milestones are reached. OPD can also include volunteer activity in decisions concerning promotions and appointments of personnel.

**Strategy:** Expand the Police Activities League (PAL) program through reassignment of personnel.

**Deadline:** January 1, 2017. **Responsible:** Chief of Police.

The OPD PAL Program is very robust and provides a large number of opportunities for Oakland youth. Initiatives sponsored by PAL include Adopt-a-Family, the Annual Christmas Dinner, Basketball, Building Strong Minds Mentorship, camping, Gang Resistance Education and Training, Track and Field, Police Explorers, Our Kids, and Youth Summer Internship. Increasing the number of personnel assigned to PAL will greatly enhance the ability of OPD to engage Oakland youth. Such increased engagement will provide the Oakland community and OPD opportunities to break down barriers while bringing greater understanding to all stakeholders.

**Strategy:** Recognize senior populations through senior safety programs.

**Deadline:** July 1, 2016. **Responsible:** Neighborhood Services Section Managers.

As the American senior population increases at an unprecedented rate, every city large and small must address the needs that accompany this shift. In Oakland, more could be done to recognize this significant increase and the unfortunate victimization that comes with it. By reaching out to seniors and educating them about crimes that target seniors – particularly financial crimes – OPD could further engage another segment of our community.

**Strategy:** Increase participation of Community Resource Officers in social media platforms and electronic communications.

**Deadline:** July 1, 2016. **Responsible:** Patrol Area Commanders.

A great many opportunities exist for traditional and community-based law enforcement providers to further engage the public through social media and electronic communication. As the San Francisco Bay Area continues to be home to the largest number of technology companies – and workers – in the world, our community expects to be reached through non-traditional methods. While OPD has social media presence, greater opportunity exists to share – and receive – information through electronic methods. Community Resource Officers, in particular, have great opportunity to utilize such means in working with their assigned neighborhoods.

**Strategy:** Implement a robust volunteer program for community members.

**Deadline:** July 1, 2016. **Responsible:** Neighborhood Services Section Managers.

OPD receives dozens of inquiries annually from community members looking to volunteer. Unfortunately, the current volunteer program does not adequately connect interested volunteers with Department need. Providing stronger support for community volunteers at all levels of the organization – along with additional structure and processes – will result in a more satisfying and productive experience for all involved.



## GOAL 3: ACHIEVE ORGANIZATIONAL EXCELLENCE

Like every American law enforcement agency, the Oakland Police Department is charged with a multitude of responsibilities beyond reducing crime. The most important responsibility in this list is achieving organizational excellence. In direct relationship to the sobering volume of violent and property crime, OPD is faced with tremendous challenges in providing quality police service and a desirable working environment. Challenges in providing quality police service include responding to and documenting incidents timely and sufficiently. Challenges in providing a desirable working environment include navigating a challenging political environment, providing worthwhile professional development, properly equipping staff, and ensuring the mental and physical well-being of OPD members.

**Response times to emergency and non-emergency calls in the City of Oakland are unacceptable.** Members of the public who call to report for a non-life-threatening event may wait several hours – even days – for a member of OPD to respond to a residence or business. Many quality of life calls receive no response due to call volume. Additionally, the amount of cases to investigate presents real challenges for quality follow-up investigations on all cases. As an agency, we desire to perform better service those who are victims of crime. Follow up investigation is not generally provided for the vast majority of property crimes as well as some shootings and many robberies.

The Oakland Police Department has undergone tremendous change in the last several years. This has caused the organization to increase accountability and have difficult conversations about old policies and practices. This change has not been easy, but necessary. Some of the changes let to a sense of more restrictive policies and the perception of an unfair disciplinary process and outcomes have demoralized the OPD. We take this issue seriously and are implementing changes to improve in this area. Economy-driven layoffs, dilapidated work spaces, and inferior equipment have also contributed to a very challenging work environment. The Department is working to improve all of these areas. With the continued support of funding and resources, it is hoped that OPD will become an employer of choice.

### **21<sup>st</sup> Century Policing: Achieving Organizational Excellence**

Achieving Organizational Excellence requires OPD to act upon the fourth and fifth of the six pillars (main topic areas) provided by the *Final Report of the President's Task Force on 21<sup>st</sup> Century Policing*. The fourth and fifth pillars are:

- Training and Education
- Officer Wellness and Safety

#### *Training and Education*

Concerning the fifth pillar in the *Final Report of the President's Task Force on 21<sup>st</sup> Century Policing*, the report states: "Hiring officers who reflect the community they serve is important not only to external relations but also to increasing understanding within the agency."<sup>1</sup> Specific 21<sup>st</sup> Century Task Force recommendations concerning training and education include:

---

<sup>1</sup> *Final Report of the President's Task Force on 21<sup>st</sup> Century Policing*, (May 2015, Office of Community Oriented Policing Services, [http://www.cops.usdoj.gov/pdf/taskforce/taskforce\\_finalreport.pdf](http://www.cops.usdoj.gov/pdf/taskforce/taskforce_finalreport.pdf)), p. 51

- Engage community members in the training process.
- Provide leadership training to all personnel throughout their careers.

Specific examples responsive to the *21<sup>st</sup> Century Task Force* recommendations for training and education include:

- Inviting 10 to 12 community groups into the basic police academy to share their perspectives with the trainees.
- Conducting two citizen police academies each year.
- Creating and delivering procedural justice training with community members.

#### *Officer Wellness and Safety*

Concerning the sixth pillar, the *21<sup>st</sup> Century Policing* report states: “The wellness and safety of law enforcement officers is critical not only to themselves, their colleagues, and their agencies but also to public safety.”<sup>1</sup> Specific *21<sup>st</sup> Task Force* recommendations concerning officer wellness and safety include:

- Law enforcement agencies should promote safety and wellness at every level of the organization.
- Every law enforcement officer should be provided with individual tactical first aid kits and training as well as anti-ballistic vests.

Specific examples responsive to the *21<sup>st</sup> Century Task Force* recommendations for officer wellness and safety include:

- Upgrading of an early-warning system that OPD has used for several years to identify concerns in conduct and performance in order to provide officers with needed resources including psychological support.
- Creation of a Wellness Unit will encompass several existing OPD initiatives such as the Peer Support Program, Critical Incident Response Team, Mental Health Provider Referral Program, Substance Abuse Referral Program, Clinical Psychologist Referral Program, Chaplain Program, and Employee Assistance Program.
- Providing all officers with ballistic vests and trauma kits.

#### **Performance Measures for Achieving Organizational Excellence**

Similar to Goal 2: Strengthen Community Trust and Relationships, the first performance measure for this goal is community satisfaction. The most recent (2013-14) community survey conducted by OPD found that, of 1,353 respondents, 38 percent were very satisfied or satisfied with the service they received and 32 percent were dissatisfied or very dissatisfied. In the same survey, 33 percent of respondents were very satisfied or satisfied with the response time of OPD and 43 percent were dissatisfied or very dissatisfied. A new survey will be conducted in 2016. Additional performance measures include reduction in Priority 1 and Priority 2 response times and call answering times.

The second performance measure for Goal 3: Achieving Organizational Excellence is employee satisfaction and the third performance measure is employee turnover. In the 2013 OPD Sworn Employee Survey, only 35 percent of the sworn staff and 41 percent of the civilian staff felt valued by the Department for the work they do. As of the writing of this report, the Oakland

---

<sup>1</sup> Ibid, p. 61

Police Department has an annual sworn turnover rate of nearly 10 percent. Approximately six officers separate from OPD each month. Nearly 40 percent of these separations are resignations and more than half of these resignations lead to officers being hired with other law enforcement agencies.

### **Objectives and Strategies for Achieving Organizational Excellence**

In order to ensure implementation of this plan, it is also scalable. Parallel objectives – and accompanying strategies – are again provided for this goal in order to ensure that objectives are reachable with or without additional resources.

#### **Achieving Organizational Excellence: No Additional Resources**

**Objective: Increase community satisfaction by 15% over 36 months.**

**Objective: Reduce Priority 1 and Priority 2 response times by 15% over 36 months.**

**Strategy:** Provide appointment-setting for police reports.

**Deadline:** July 1, 2016.      **Responsible:** Communications Division Manager.

As provided in the *Best Practices Review*,<sup>1</sup> appointment-setting for report-taking is recommended as an effective call management strategy. At present, members of the public contact OPD and request a response to take a report. This response is the lowest dispatch priority and the public is often forced to wait hours – and sometimes days – for an OPD response to take a report at an unknown time. Scheduling an appointment with a Police Service Technician II will provide the public with the certainty of a fixed date and time to meet with OPD and make the report. Any loss of convenience of having an OPD member come to a residence or business will be outweighed by the **convenience of the appointment. This service should increase community satisfaction while reducing response times (due to fewer calls being dispatched).**

**Strategy:** Analyze the Patrol beat structure.

**Deadline:** January 1, 2017.      **Responsible:** Research and Planning Manager.

The current OPD structure has been substantially unchanged since the mid-1970s. Great disparities exist among the current 35 beats, with one beat providing over 30,000 calls per year and another providing fewer than 6,000. **Realigning beats to better distribute workload – while still respecting obvious natural boundaries and neighborhoods – should result in greater efficiencies, increased community satisfaction, and reduced response times.**

**Strategy:** Analyze Patrol schedules.

**Deadline:** January 1, 2017.      **Responsible:** Research and Planning Manager.

The current OPD patrol schedule includes four shifts, three of which are 10 hours in length and the fourth is 12 hours in length. Two of the 10-hour shifts (1<sup>st</sup> Watch/Day Watch and 3<sup>rd</sup> Watch/Dog Watch/Graveyard) have overlapping teams once a week and multiple briefings each

<sup>1</sup> *Best Practices Review: Oakland Police Department 2013* (October 2013, Strategic Policy Partnership, LLC: <http://www2.oaklandnet.com/oakca1/groups/police/documents/webcontent/oak045374.pdf>)

day. Depending on the day of the week, there may be six briefings at each of the two OPD patrol facilities – resulting in 12 briefings covering four shifts. More importantly, there is little data that the current patrol schedule aligns personnel with call load. An analysis of call load by day of week and time of day should identify time of greatest need of personnel as well as time of least need. **Aligning patrol schedules with this data should result in greater efficiencies, increased community satisfaction, and reduced response times.**

**Strategy:** Contact every crime victim.

**Deadline:** April 1, 2016.      **Responsible:** Criminal Investigations Division Commander.

An opportunity exists for OPD to contact members of the public who have filed a report and provide any updates while checking for additional information. This practice would reassure the public that every crime counts and help OPD acquire any new information from the victim. In order to be cost neutral, **volunteers are sought to perform this function.**

**Strategy:** Provide business cards for every investigative consensual encounter and detention.

**Deadline:** July 1, 2016.      **Responsible:** BFO Administration Division Commander.

In order to ensure that the public is getting the best service possible from OPD, every Department member should provide a business card each time contact with a member of the public results in an investigative consensual encounter or detention. The business card should provide the Department member's name and serial number along with helpful information about OPD, the City of Oakland, other resources, and processes for follow up. Though there will be some cost to provide all OPD members who have public contact with business cards, this cost should be minimal and absorbed into OPD's General Purpose Fund budget.

**Strategy:** Provide greater customer service at the Patrol Administration Building.

**Deadline:** January 1, 2017.      **Responsible:** Personnel and Training Division Commander.

The OPD Police Administration Building lobby is large and confusing. The service counters are encased in bullet-proof glass. This results in confusion and frustration on the part of the public when they come to OPD for a needed service. Reconfiguring the reception area to provide safety to OPD personnel and better service to the public should be a low- to no-cost strategy. Stationing OPD volunteer staff in the lobby to direct the public should greatly reduce confusion and frustration. Upgrading the intercom at the front desk would also provide greater customer service.

**Objective: Increase employee satisfaction by 30% over 36 months.**

**Strategy:** Create an Employee Wellness Unit.

**Deadline:** September 1, 2016.      **Responsible:** Personnel and Training Division Commander.

The creation of a Wellness Unit will allow OPD to provide a central location for all wellness programs and services. An Informational Report concerning the creation of a Wellness Unit was accepted by the City of Oakland City Council Public Safety Committee on October 13,

2015. The report details assignment of a Sergeant of Police to supervise the unit and the expenditure of previously approved funding for an Administrative Analyst II and Program Intern. Funding is also approved for building costs, materials, and professional service agreements to assist OPD staff in administering the following programs:

- Peer Support Program
- Critical Incident Response Team
- Mental Health Provider Referral
- Substance Abuse Program Referral
- Clinical Psychologist Referral
- Chaplain Program
- Employee Assistance Program Referral

Providing OPD personnel with greater emotional support should also provide them with greater job satisfaction.

**Strategy:** Provide job-sharing for OPD Personnel.

**Deadline:** January 1, 2018.      **Responsible:** Personnel and Training Division Commander.

The California Commission on Peace Officer Standards and Training (POST) allows sworn law enforcement personnel to reduce to move in and out of full-time status under as a Per Diem Officer. Allowing sworn and civilian OPD employees to reduce the number of hours worked to less than full-time will provide flexibility not currently available to full-time personnel. This flexibility will allow personnel to engage in other life events for determined time periods, such as caring for children or other family members or furthering education. Having such options should increase the recruitment and retention of female personnel, as women are still the primary caregivers in American society. Organizational impact should be minimal, as each request will be evaluated individually. **Providing OPD personnel with more flexible schedule options should also provide them with greater job satisfaction.**

#### **Achieving Organizational Excellence: Additional Resources**

**Objective: Increase community satisfaction by 30% over 36 months.**  
**Objective: Reduce Priority 1 and Priority 2 response times by 30% over 36 months.**  
**Objective: Reduce call answering times by 15% over 36 months.**

**Strategy:** Implement a 3-1-1 System.

**Deadline:** January 1, 2018.      **Responsible:** Communications Division Manager.

The *Best Practices Review* recommends implementation of a 3-1-1 system as an effective call management strategy. The implementation of a 3-1-1 non-emergency/assistance answering system will greatly reduce calls to the OPD Communications Center on both emergency and non-emergency numbers. This should, in turn, greatly increase community satisfaction and reduce OPD response times as the amount of time required to answer a call and assign OPD resources will be reduced. **Assigning responsibility for the 3-1-1 system to an entity other than OPD would be most appropriate, as the expected calls should not be requests for police services.**

**Resources:** Unknown.

**Funding Sources:** Unknown

**Strategy:** Accept all wireless 9-1-1 calls.

**Deadline:** January 1, 2019. **Responsible:** Communications Division Manager.

OPD is moving forward with implementing the necessary tools to accept wireless 9-1-1 calls. This should reduce call wait times, as callers on wireless devices will no longer be routed to the California Highway Patrol before being transferred to OPD. **Both human and technological (GIS mapping) resources will be required to enact this strategy.**

**Resources:** Fourteen additional Police Communication Operators and GIS mapping technology.

**Funding Sources:** A General Purpose Fund appropriation is needed for the ongoing personnel costs of additional Public Safety Dispatchers. State funding will cover the majority of equipment costs necessary for a 9-1-1 GIS mapping system with only a small, one-time contribution required of the City of Oakland from the General Purpose Fund.

**Objective:** Reduce the number of persons killed and injured in traffic collisions by 15% over 36 months.

**Strategy:** Assign additional resources to Traffic Safety.

**Deadline:** July 1, 2016. **Responsible:** Chief of Police.

The City of Oakland has a significant number of fatal traffic collisions every year. In order to reduce this, increased analysis of primary and associated collision factors and strategic deployment of personnel is needed. Since OPD has very few personnel assigned to the Traffic Enforcement Unit, an additional squad would greatly enhance OPD efforts to target specific violations at targeted locations.

**Resources:** One additional Sergeant of Police and eight Police Officers.

**Funding Sources:** A General Purpose Fund appropriation is needed for the ongoing personnel costs of an additional Sergeant of Police and eight Police Officers. One-time funding is needed for the purchase of additional motorcycles and ongoing funding is needed for maintenance costs for the additional motorcycles.

## Appendix I: Reports and Recommendations Concerning the Oakland Police Department

### *District-Based Investigations in Oakland*

In the May 2013 report on district-based investigations, the Bratton Group recommended that each of the five patrol areas be staffed with a District-Investigative Unit (DIU) made up of an investigative sergeant, three experienced investigators, and three to five police officers to investigate robbery, burglary, and shootings/assaults. The recommendation was that the DIU would work staggered hours in the afternoons and evenings seven days a week. This would allow DIU personnel to respond to crime scenes to interview victims, canvass for witness, and gather evidence. The DIU sergeant would be responsible for coordinating with the Criminal Investigations Division (CID), evidence technicians, and the crime lab. The DIU sergeant would also report to the Area Captain and represent district investigations at CompStat meetings.

OPD has instituted limited use of patrol area-based felony assault, burglary, and robbery investigators. Complete implementation of the DIU model has not taken place due to a lack of staffing, an inability to prioritize investigations across geographic areas, and inconsistency of training received and skill level among decentralized staff. Seventeen of the 19 investigators are assigned by patrol area within CID, as follows:

- All seven felony assault investigators are assigned by patrol area
- All five burglary investigators are assigned by patrol area
- Five of the seven robbery investigators are assigned by patrol area

Further implementation of the DIU recommendation is included as a strategy, with a focus on robbery.

The *District-Based Investigations* report recommends the processing and examination of fingerprint evidence collected from burglaries. A modified version of this recommendation is incorporated as Strategy 1.4.1. The report also states “an analysis of links between firearms and crimes and firearms and gangs would be extremely useful in identifying targets for the Ceasefire effort and in directing and coordinating enforcement actions related to Ceasefire.”<sup>1</sup> This recommendation is being incorporated into an initiative funded in the FY 2015-2107 City of Oakland Policy Budget and is included as a strategy.

The *District-Based Investigations* report addressed concerns with crime scene technicians (Police Evidence Technicians), including a lack of administrative support. The report stated that the “evidence technician unit is being transferred to the Central Investigation Division.” The unit was transferred to the newly recreated Bureau of Investigations in late 2015 and is now supervised by a Sergeant of Police.

The OPD CompStat process was discussed in an appendix to the *District-Based Investigations* report. The report stated the “OPD CompStat process itself requires significant revision”<sup>2</sup> and that “[t]he purpose of the CompStat process is to provide vigorous strategic oversight of a police department’s crime fighting efforts ...[with] exchanges focused on the specifics of crime patterns and individual crimes and the measures being taken to counter them.”<sup>3</sup> As outlined in the

---

<sup>1</sup> Ibid, p. 10

<sup>2</sup> Ibid, p. 21

<sup>3</sup> Ibid, pp. 21-22

appendix concerning CompStat Meetings and Reporting Requirements, there are four elements required for CompStat to be successful in reducing crime:<sup>1</sup>

1. Accurate and Timely Information
2. Effective Tactics
3. Rapid Deployment of Personnel and Resources
4. Relentless Follow-Up and Assessment

OPD is working to develop the capacity to provide accurate and timely information on crime, crime patterns, and crime trends. Funding has been approved for the implementation of a Crime Analysis Section to be staffed by a Police Services Manager and five Crime Analysts (included as a strategy). Once this section has been implemented, accurate and timely information will be readily available for use in CompStat.

OPD has recently bolstered agency-wide resources through a partial re-organization. Ceasefire now has a Captain of Police, a Project Manager II, a Lieutenant of Police, five Sergeants of Police, and 24 Police Officers assigned to it to respond to group-involved incidents such as shootings. OPD has limited capacity to rapidly deploy personnel and resources on a scale typically required for effective use of CompStat. In cities such as New York and Los Angeles, tremendous agency-wide law enforcement resources can be moved from one area to another to address priority crime problems. This limited capacity to rapidly deploy directly affects the ability to provide relentless follow-up and assessment. In this period of transition, the Department one commander report out during an hour-long crime meeting. The reporting includes crime trends, crime statistics, and solutions. The Executive Team is able to ask questions and realign resources based upon needs

While OPD does not have the resources required of traditional CompStat – particularly those for relentless follow-up and assessment, OPD is continuing to develop a modified approach that includes daily crime conference calls, weekly shooting reviews, weekly area specific crime trend review meetings, time-specific crime reduction plans, and wide-ranging implementation of Ceasefire.

#### *Best Practices Review: Oakland*

In the October 2013 *Best Practices Review*, the Strategy Policy Partnership provided recommendations based on nationwide best practices. These recommendations were grouped into 15 major areas,<sup>2</sup> ranging from “Building Communities of Trust” to “Recruitment of Candidates.”

In the first major recommendation area (Building Communities of Trust), the *Best Practices Review* provides four reasons for the divide between OPD and the Oakland community: a widespread perception that OPD does not treat community members with respect; a tendency of political figures to feed off criticism of OPD in the absence of facts; unusually high levels of media scrutiny and ineffective communication strategies; and violent public demonstrations that often target OPD. OPD has addressed many of these issues in the last two years. Procedural justice training has been provided to all sworn OPD personnel. A more effective application of

---

<sup>1</sup> Ibid, p. 32

<sup>2</sup> *Best Practices Review: Oakland Police Department 2013* (October 2013, Strategic Policy Partnership, LLC: <http://www2.oaklandnet.com/oakca1/groups/police/documents/webcontent/oak045374.pdf>) , p. 3



the protest response policy seems to have contributed to a dramatic reduction in the number of protests and the violence and damage associated with them.

The *Best Practices Review* provides that OPD needs to include the Oakland community in crime analysis and operational planning and that the community needs to share responsibility in addressing crime and violence.<sup>1</sup> The second goal of this strategic plan is to strengthen community trust and relationships. A number of strategies are proposed to bring OPD closer to the Oakland community throughout this plan, including expanded use of procedural justice training and inviting community members to take a more active role in crime analysis and operational planning.

In the second major recommendation area (Accountability-Based Police Structure), the *Best Practices Review* provides that the Assistant Chief of Police focus exclusively on operations (patrol, investigations, special operations, and strategic initiatives). This recommendation was enacted in the summer of 2015. OPD has enacted all structural recommendations, including two Deputy Chiefs of Police to oversee the five districts (patrol areas) and a command officer overseeing Ceasefire and CompStat. An assessment of crime analysis needs – including placement of the Crime Analysis Section in the organizational structure – has taken place. The final recommendations in this section, implementation of district-based investigations and coupling problem-solving officers (now community resource officers) with patrol officers are addressed in this strategic plan.

In the third major recommendation area (Neighborhood Policing Structure), the *Best Practices Review* provides that each of the patrol areas be commanded by a Captain of Police. OPD has enacted most of the recommendations in this area, including assigning patrol response units and problem-solving officers (PSOs, now CROs) to the patrol area captain, and the establishment of a community advisory group by each patrol area captain. OPD has exceeded the recommendation that each patrol area have a Lieutenant of Police to oversee patrol and a second lieutenant to oversee problem-solving officers, crime response teams (CRTs), and other specialized units. There are actually two patrol lieutenants assigned to each area and a third lieutenant overseeing CROs, CRTs, and other specialized units. The only recommendation that OPD has not enacted is that of a single city-wide watch commander. This recommendation is impractical based on activity level.

In the fourth major recommendation area (Developing a Service Culture), the *Best Practices Review* states that policing culture can change “when senior managers are vocal, articulate purveyors of the vision for the future...”<sup>2</sup> OPD has implemented many of the recommendations in this area, including the presence of command staff at patrol line-up. The fifth recommendation area (Developing Management Skill) includes specific recommendations such as visits by promoting personnel to other agencies with identified best practices; promoting only those captains to deputy chief who have commanded a district; and having command staff members serve as liaisons to other City agencies and community organizations. Participation in management programs beyond the Senior Management Institute Program run by the Police Executive Research Forum (PERF) is encouraged. Succession planning and greater development of all staff – including managers – is addressed in the third goal of this strategic plan – achieving organizational excellence.

---

<sup>1</sup> Ibid

<sup>2</sup> *Best Practices Review: Oakland Police Department 2013* (October 2013, Strategic Policy Partnership, LLC: <http://www2.oaklandnet.com/oakca1/groups/police/documents/webcontent/oak045374.pdf>), p. 15

The sixth major recommendation area (Addressing Crime) reiterates the recommendations of the *District-Based Investigations* report and further states “[i]t is imperative that the Department adopt an aggressive, real-time response to Ceasefire group violent events as soon as they occur after a group has been identified as violent...Ceasefire performance should be incorporated into the CompStat process to ensure Ceasefire actions aimed at preventing violent crime are focused and effective.”<sup>1</sup> OPD has instituted a weekly shooting review, a meeting of commanders and other key staff who have direct involvement in the reduction of violent crime. The shooting review has been expanded beyond shootings and homicides to include robberies. Shooting review is facilitated by the Ceasefire commander and focuses on the gathering and dissemination of actionable intelligence.

The seventh major recommendation area (Strengthening Police Training) focuses on involving community members in recruit officer and in-service officer training. OPD has implemented these recommendations and supplemented them with community members helping to design and deliver the procedural justice training. The eighth major recommendation area (Performance Evaluation) includes a recommendation that “the performance evaluation process...be structured so it is positive for officers, and includes assessment of individuals’ strengths, as well as areas in which they need to improve performance...[and] must be tied to career development and early intervention, identifying problems before they become disciplinary or performance problems.”<sup>2</sup> OPD has implemented such a performance evaluation process.

The ninth major recommendation area (Internal Affairs Processes) sets forth a number of recommendations to simplify processes and still meet requirements of the Negotiated Settlement Agreement, including limiting the role of the Intake Officer to logging complaints into the system, checking for prior complaints and classifying complaints forming the basis of assignment for investigation. This has been done. The second recommendation was to replace sworn intake personnel with civilians (in part to free up sworn personnel to do neighborhood policing). This has occurred, though employee turnover has been very challenging. The third recommendation was to develop guidelines as to when a case will be investigated first as a crime and this has been done. The fourth recommendation was that informal complaint resolution should not be imposed by the Internal Affairs Command. This practice has been minimized, as it affects an incredibly small percentage of complaints. The fifth recommendation concerns the criticism of the Monitor regarding the number of closures without investigation. OPD does not investigate a complaint unless the complaint alleges misconduct or violation of a rule. For example, OPD does not investigate complaints about noise from the OPD helicopter. Every misconduct allegation is investigated. The sixth recommendation is that the role of the Internal Affairs investigator needs to be better defined and focus on who recommends a penalty. OPD uses a practice that is required by the Negotiated Settlement Agreement. The discipline policy was recently revised.

The tenth major recommendation area (Managing Calls for Service) includes alternatives to dispatching an officer in response to every call. These recommendations include appointment setting for an officer to contact the complainant at a later time; handling calls over the phone rather than dispatching an officer; an increased ability for the public to report over the internet; and the use of 311 for calls that can be handled by other agencies. All of the above recommendations are included in this strategic plan in the third goal, provide quality police service.

---

<sup>1</sup> Ibid , p. 20

<sup>2</sup> *Best Practices Review: Oakland Police Department 2013* (October 2013, Strategic Policy Partnership, LLC: <http://www2.oaklandnet.com/oakca1/groups/police/documents/webcontent/oak045374.pdf>), p. 25

The eleventh major recommendation area (The Ceasefire Connection) articulates a number of recommendations to ensure the most effective implementation of this crime-reduction strategy. Much progress has been made in doing so in OPD – particularly with the assignment of additional personnel (a lieutenant and several sergeants and officers, discussed above). Additional opportunities to educate the public, members of OPD, and other stakeholders about Ceasefire still exist along with opportunities to work more closely with community partners in implementation. The twelfth major recommendation area (Racial Profiling Data Analysis) states that analysis of racial profiling data be performed by an outside expert. OPD has contracted with award-winning Stanford University Professor Jennifer Eberhardt to perform this analysis.

The thirteenth major recommendation area (Crisis Intervention Skill Development) includes a recommendation that “the Department create a crisis intervention team consisting of police, school staff and community representatives to respond to situations when there is a high potential for violence or disruptive activities.”<sup>1</sup> OPD has a Police Officer in the Training Section whose exclusive assignment is to address mental health issues and crisis intervention training. OPD provides a 38-hour POST-certified crisis intervention team training course. As of July 1, 2015, over a hundred OPD officers have completed this training. OPD also provides a 16-hour POST-certified crisis intervention course for Public Safety Dispatchers and has trained 34 dispatchers. OPD has developed a collaborative work-group that brings together all local stakeholders to discuss law enforcement concerns regarding individuals with mental health issues. OPD also collaborated with Alameda County Health to implement a pilot program that paired CIT-trained officers with licensed clinical social workers to respond to designated calls for service.

The fourteenth major recommendation area (Reducing Domestic Homicides) focused on identifying potential domestic homicides before they occur. A specific recommendation was made that OPD “partner with local researchers to undertake an analysis of domestic violence situations in Oakland over the [previous] five years to determine the elements that form the basis of determining when...intervention is needed.”<sup>2</sup> OPD made contact with UC Berkeley research staff about partnering on this project.

The fifteenth major recommendation area (Recruitment of Candidates) includes recommendations that OPD raise its minimum age for recruits to 25 so that applicants have sufficient life experience with exceptions for college and military or police experience (including serving as an intern or cadet). The *Best Practices Review* also recommends that interview panels “reflect the diversity of the community and not just be police supporters.”<sup>3</sup> The report recommends that the Oakland community – through the district advisory committees – engage in finding local candidates and that OPD hire as many Oakland residents as possible as Cadets. The minimum age for Police Officer Trainee (recruit) remains 21. City funding has been approved – with additional (private) funding expected – to increase the number of Police Cadets by 26 positions for three years.

#### *Addressing Crime in Oakland: Zeroing Out Crime*

This report provides a number of recommendations concerning public safety in the City of Oakland. Most of those involving the Oakland Police Department are covered in the two previous reports. This information is supplemented by “an asset inventory of the larger City

---

<sup>1</sup> Ibid, p. 34

*Best Practices Review: Oakland Police Department 2013* (October 2013, Strategic Policy Partnership, LLC: <http://www2.oaklandnet.com/oakca1/groups/police/documents/webcontent/oak045374.pdf>), p. 36

<sup>3</sup> Ibid, p. 37

organization and its Departments, of services that all support crime reduction in a holistic crime reduction plan.”<sup>1</sup> Though much of *Zeroing Out Crime* focuses on service providers other than OPD and reiterating recommendations from the two previous reports, there are some recommendations that are worth reviewing in this strategic plan.

The first recommendation area for OPD in *Zeroing Out Crime* worth reviewing is the expansion of the Ceasefire initiative. As discussed previously in this strategic plan, much progress has been made in expanding Ceasefire. *Zeroing Out Crime* recommends building community support – particularly among faith communities; identifying persons most at risk of involvement in violent acts; calling in leaders of violent groups and advising them of consequences and alternatives; and forming strong collaborations among criminal justice partner agencies to assist with rapid enforcement. All of these recommendations have been implemented.

The second worthwhile recommendation area for OPD in *Zeroing Out Crime* is the proper implementation of community policing. Specific recommendations include returning of Neighborhood Service Coordinators to OPD. This occurred in late 2014. The report recommends that outcomes – not number of projects initiated – be used to measure effectiveness of community policing efforts. This strategic plan is an attempt to move the entire organization toward the measurement of outcomes (objectives) and not outputs. Restorative justice is recommended as an effective community policing strategy. It is used by members of the OPD Youth and School Services Section.

In the third worthwhile recommendation area, *Zeroing Out Crime* recommends that OPD increase staffing based on a number of criteria including population, response times, crime levels, geographic coverage, major events, calls for service reduction initiatives, and personnel attrition. “Using a strict ratio per thousand formula is not an appropriate measurement for Oakland because of the level of violent crime and nature of disorder.”<sup>2</sup> The report then recommends two sworn personnel per 1,000 residents and recommends prioritizing as follows: full staffing of police areas, DIUs, homicide investigators, and Ceasefire intelligence staffing. Civilianization is recommended – with the caveat that “it is a serious mistake to only add Officers.”<sup>3</sup> Forty sworn personnel will be added to OPD in FY 2016-17. A number of civilian positions were also requested in the same biannual budget and a few were added. Many more sworn positions could be replaced with civilians, providing a cost-effective way to move more officers into sworn-only positions and provide consistency – and increased expertise – in the civilian positions they would vacate.

*Zeroing Out Crime* provides three additional worthwhile specific recommendations for OPD. First, the Department should seek accreditation from the Commission on Accreditation of Law Enforcement Agencies (CALEA). This process has begun with the attendance of the annual CALEA spring meeting in 2015. Second, OPD should make better use of “social media, the Department’s website, traditional media, and email blasts to keep people informed.”<sup>4</sup> The report also recommends a Department update as a standing item on the City Council agenda and

---

<sup>1</sup> *Addressing Crime in Oakland: Zeroing Out Crime, A Strategy for Total Community Action* (December 2013, Strategic Policy Partnership, LLC: <http://www2.oaklandnet.com/oakca1/groups/police/documents/webcontent/oak045375.pdf>), Cover Memo

<sup>2</sup> *Addressing Crime in Oakland: Zeroing Out Crime, A Strategy for Total Community Action* (December 2013, Strategic Policy Partnership, LLC: <http://www2.oaklandnet.com/oakca1/groups/police/documents/webcontent/oak045375.pdf>), p. 24

<sup>3</sup> Ibid.

<sup>4</sup> Ibid, p. 25

development of a public service campaign. Finally, Zeroing Out Crime recommends that Measure Y (now Measure Z) officers receive an incentive to stay their positions for at least a year and not be drawn from their neighborhood assignments short of a true emergency.

## Appendix II: The 2016 Oakland Police Department Strategic Planning Process

The Strategic Planning Group met bi-weekly from November 2014 through March 2015. The Command Staff met bi-weekly during April and May 2015, primarily to discuss additional objectives and strategies. The timeline for the first Strategic Planning Group was as follows:

November 19, 2014

- Introductory Exercise
- Ground Rules
- Overview of Process
- What a Strategic Plan Should Be
- What a Strategic Plans Should Not Be
- SWOC Exercise
- Identify Organizational Mandates
- Clarify Organizational Values (draft)

December 3, 2014

- Review of Strengths, Weaknesses, Opportunities, and Challenges (SWOC)
- Clarify Organizational Values
- Clarify Organizational Mission
- Establish Effective Vision (draft)

December 17, 2014

- Establish Effective Vision (draft)
- Articulate Goals

January 7, 2015

- Establish Effective Vision
- Articulate Goals
- Formulate Objectives

January 21, 2015

- Formulate Objectives

February 4, 2015

- Review Goals

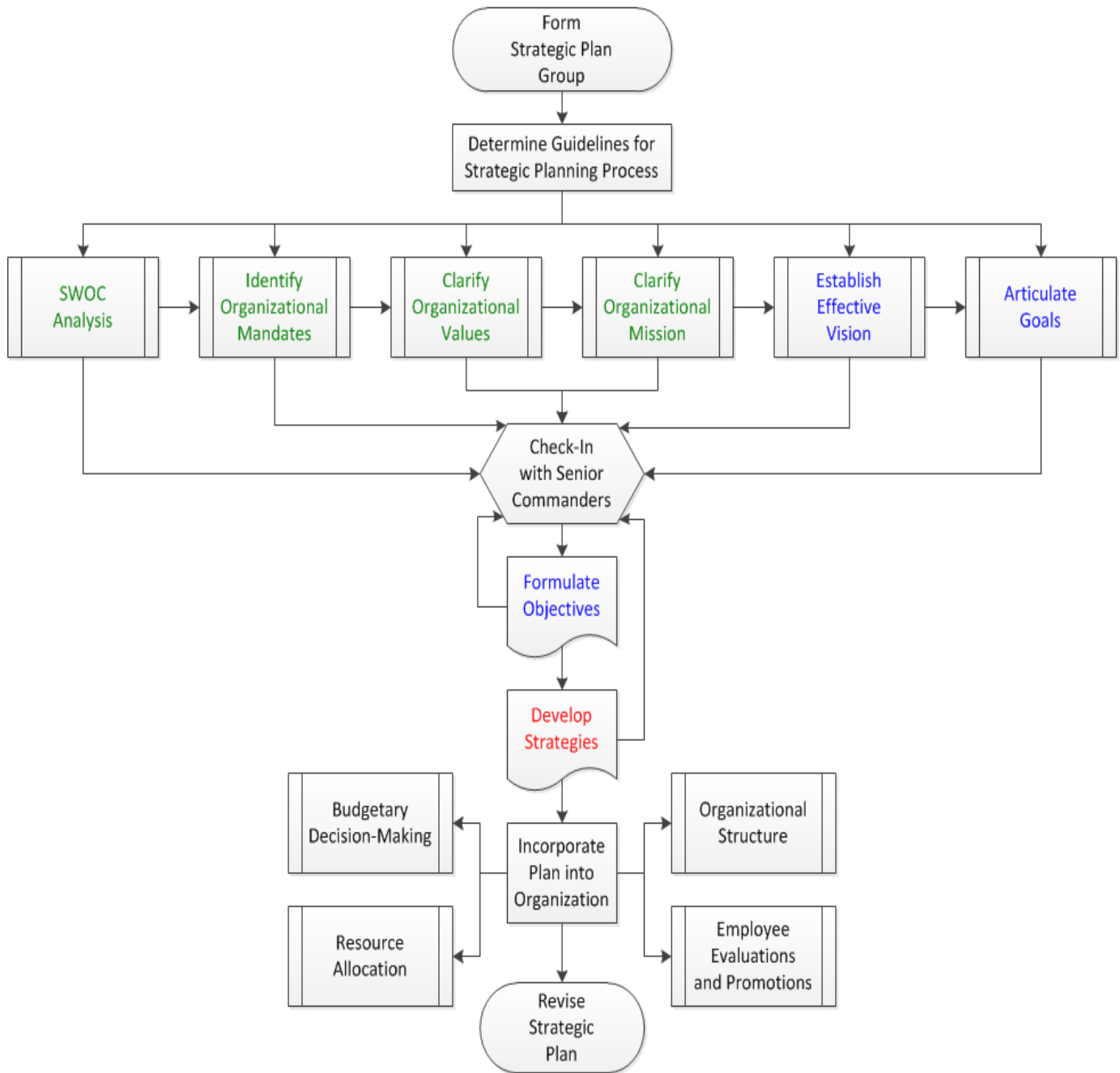
February 18, 2015

- Update Goals
- Formulate Objectives
- Develop Strategies

March 18, 2015

- Develop Strategies

Phase	Action
Where we are	Analyze Strengths, Weaknesses, Opportunities, Challenges
	Identify Organizational Mandates
	Clarify Organizational Values
	Clarify Organizational Mission
Where we want to be	Establish Effective Vision
	Articulate Goals
	Formulate Objectives
How we are going to get there	Develop Strategies



The second working group for the strategic plan was made up of OPD Command Staff. OPD Command Staff met in May through July 2015 to further develop the first goal. The timeline for the second Strategic Planning Group was as follows:

May 20, 2015

- Review existing strategies
- Identify effective strategies
- Identify strategies that can be improved

June 3, 2015

- General discussion of crime control strategies

June 24, 2015

- Formulate Objectives with existing resources
- Develop Strategies with existing resources

July 1, 2015

- Identify additional resources
- Formulate Objectives with additional resources
- Develop Strategies with additional resources

There were two working groups who took part in the strategic planning process at OPD. The first was the Strategic Planning Group. This group was made up of members of the Oakland community; members of the Oakland City Administrator's Office; and members of the Oakland Police Department. Oakland Police Department members included representatives of various divisions as well as a representative of each of the three unions in OPD.

The below individuals took part in the planning process that spanned November 2014 through March 2015:

Members of the Community

- Mr. Jose Dorado, Measure Y Committee
- Mr. Marcus Johnson, Community Police Advisory Board

Members of the Oakland City Administrator's Office

- Assistant to the City Administrator Chantal Cotton
- Assistant to the City Administrator Joseph DeVries
- Executive Director Anthony Finnell, Citizens' Police Review Board
- City Administrator Analyst Shana Sharp

Members of the Oakland Police Department

- Lieutenant LeRonne Armstrong, Criminal Investigation Division
- Timothy Birch, Research and Planning
- Officer Omar Daza-Quiroz, Criminal Investigation Division
- Project Manager II Reygan Harmon, Ceasefire
- Sergeant Bryan Hubbard<sup>1</sup>, Personnel and Training Division
- Account Clerk II Karen Lu,<sup>2</sup> Fiscal Services

---

<sup>1</sup> As a representative of the Oakland Police Officers Association (OPOA)

<sup>2</sup> As a representative of Local 1021



- Officer Jennifer Sena, Support Operations Division
- Police Communications Supervisor Ametrius Sidney, Communications Division
- Neighborhood Services Coordinator Renee Sykes<sup>1</sup>, Neighborhood Services
- Sergeant Jeff Thomason, Bureau of Field Operations

The below individuals took part in the planning process that spanned May through July 2015:

- Captain Darren Allison, Bureau of Field Operations
- Lieutenant LeRonne Armstrong, Criminal Investigation Division
- Lieutenant Jake Bassett, Bureau of Field Operations
- Lieutenant Randy Brandwood, Bureau of Field Operations
- Deputy Chief Eric Breshears (retired)
- Captain Kirk Coleman, Criminal Investigation Division
- Deputy Chief Oliver Cunningham, Bureau of Field Operations
- Assistant Chief Paul Figueroa
- Lieutenant Sean Fleming, Bureau of Field Operations
- Captain Freddie Hamilton, Bureau of Field Operations
- Project Manager II Reygan Harmon, Ceasefire
- Lieutenant Roland Holmgren, Criminal Investigation Division
- Lieutenant Bobby Hookfin, Bureau of Field Operations
- Sergeant Holly Joshi, Chief of Staff
- Captain Drennon Lindsey, Bureau of Field Operations
- Sergeant Kevin Reed, Criminal Investigation Division
- Management Assistant Bruce Stoffmacher, Research and Planning
- Special Projects Coordinator Michael Sze, Office of the Mayor
- Captain Anthony Toribio, Bureau of Field Operations
- Lieutenant Steve Walker, Criminal Investigation Division
- Lieutenant Brandon Wehrly, Criminal Investigation Division
- Lieutenant Kevin Wiley, Criminal Investigation Division
- Captain Sharon Williams, Bureau of Field Operations
- Lieutenant Randy Wingate, Bureau of Field Operations

The final steps in the strategic planning process were review and evaluation of the goals, objectives, and strategies and assignments of strategies. This was conducted in December 2015 by the following personnel:

- Chief Sean Whent
- Assistant Chief Paul Figueroa
- Deputy Chief Oliver Cunningham, Bureau of Field Operations II
- Deputy Chief David Downing, Bureau of Field Operations I
- Deputy Chief John Lois, Bureau of Investigations
- Deputy Chief Danielle Outlaw, Bureau of Services

---

<sup>1</sup> As a representative of Local 21

**Appendix III: Objectives, Strategies, Timelines, and Position Responsible**

**Goal 1: Reduce Crime – No Additional Resources**

<b>Objectives</b>	<b>Percent</b>	<b>Timeframe</b>
<ul style="list-style-type: none"> <li>• Reduce homicide</li> <li>• Reduce robbery</li> <li>• Reduce aggravated assault (including shootings)</li> </ul>	30%	36 months
<b>Strategies</b>	<b>Deadline</b>	<b>Responsible</b>
Elicit greater assistance from community members through greater use of:		
<ul style="list-style-type: none"> <li>• Procedural justice training to include all members of OPD</li> </ul>	1 Jul 17	Personnel & Training Division
<ul style="list-style-type: none"> <li>• Education/training intervention related to implicit bias</li> </ul>	1 Jul 16	Personnel & Training Division
<ul style="list-style-type: none"> <li>• External/community information sharing</li> </ul>	1 Jul 16	Chief of Staff/ Patrol Areas
<ul style="list-style-type: none"> <li>• Interaction at crime scenes, and</li> </ul>	1 Jul 16	CID / Patrol Areas
<ul style="list-style-type: none"> <li>• Further engagement of public in Ceasefire</li> </ul>	1 Jul 16	Ceasefire/ Patrol Areas
Designate patrol officers to assist CID (weekly area reports)	1 Jul 16	Patrol Areas
Implement intelligence-led policing through creation of a Crime Analysis Section	1 Mar 16	BOI
Ensure Ceasefire strategy training Department-wide with a focus on those most involved	1 Mar 16	Personnel and Training Division
Implement gun tracing to identify, track and connect firearms	1 Mar 16	BOI
Make greater use of video recordings of public areas	1 Jan 17	BOS/ BOI

**Goal 1: Reduce Crime – Additional Resources**

<b>Objectives</b>	<b>Percent</b>	<b>Timeframe</b>
<ul style="list-style-type: none"> <li>• Reduce homicide</li> <li>• Reduce robbery</li> <li>• Reduce aggravated assault</li> </ul>	40%	36 months
<b>Strategies</b>	<b>Deadline</b>	<b>Responsible</b>
Increase number of patrol personnel	TBD	TBD
Create a fugitive apprehension team	TBD	TBD
Assign additional personnel to increase investigative capacity	TBD	TBD
Assign additional robbery investigators to CID for patrol areas (robbery rapid response team)	TBD	TBD
<b>Objectives</b>	<b>Percent</b>	<b>Timeframe</b>
Reduce property crime	TBD	TBD
<b>Strategies</b>	<b>Deadline</b>	<b>Responsible</b>
Expand biological evidence collection and processing to property crimes	TBD	TBD

## Goal 2: Strengthen Community Trust and Relationships – No Additional Resources

<b>Objectives</b>	<b>Percent</b>	<b>Timeframe</b>
<ul style="list-style-type: none"> <li>Increase community satisfaction</li> </ul>	15%	36 months
<b>Strategies</b>	<b>Timeline</b>	<b>Responsible</b>
Establish an OIS / in-custody death protocol to include the release of body-worn camera video	1 Jul 16	OCOP
Implement neighborhood outreach within 24 hours of SWAT operations and specific search warrants	1 Mar 16	Patrol Areas
Better explain homicide and shooting investigation processes to the public through advanced procedural justice training for OPD personnel	1 Jul 16	Training Division and Ceasefire
Respond to, implement, and manage the recommendations of the Stanford University report on Stop Data	1 Aug 2016	ACOP
Implement living room meetings with residents	1 Jul 16	Patrol Area Commanders
Increase the number of foot patrol officers from three to 18	1 Jul 16	OCOP
Protect homicide victims from public view at crime scenes	1 Jul 16	CID
Recognize and reward staff who volunteer their time for community service	1 Jul 16	Personnel & Training
Expand PAL program through reassignment of personnel	1 Jan 17	OCOP
Recognize senior populations through senior safety programs	1 Jul 16	Neighborhood Services
Increase participation of Community Resource Officers in social media platforms and electronic communications	1 Jul 16	Patrol Areas
Implement a robust volunteer program for community members	1 Jul 16	Neighborhood Services

### Goal 3: Achieve Organizational Excellence – No Additional Resources

<b>Objectives</b>	<b>Percent</b>	<b>Timeframe</b>
<ul style="list-style-type: none"> <li>Increase community satisfaction</li> <li>Reduce Priority 1 and Priority 2 response times</li> </ul>	15%	36 months
<b>Strategies</b>	<b>Timeline</b>	<b>Responsible</b>
Provide appointment-setting for police reports	1 Jul 16	Communications Division
Analyze the Patrol beat structure	1 Jan 17	Research & Planning
Analyze patrol schedules	1 Jan 17	Research & Planning
Contact every crime victim	1 Apr 16	CID
Provide business cards in every consensual encounter and detention	1 Jul 16	BFO Admin
Provide greater customer service at the Police Administration Building	1 Jan 17	Personnel & Training
<b>Objectives</b>	<b>Percent</b>	<b>Timeframe</b>
Increase employee satisfaction	30%	36 months
Create an employee wellness unit	1 Sep 16	Personnel & Training
Provide job-sharing for OPD personnel	1 Jan 18	Personnel & Training

### Goal 3: Achieve Organizational Excellence – Additional Resources

<b>Objectives</b>	<b>Percent</b>	<b>Timeframe</b>
<ul style="list-style-type: none"> <li>Increase community satisfaction</li> <li>Reduce Priority 1 and Priority 2 response times</li> </ul>	30%	36 months
<ul style="list-style-type: none"> <li>Reduce call answering times</li> </ul>	15%	36 months
<b>Strategies</b>	<b>Timeline</b>	<b>Responsible</b>
Implement a 3-1-1 system	1 Jan 18	Communications Division
Accept all wireless 9-1-1 calls	1 Jan 19	Communications Division
Assign additional resources to Traffic Safety	1 Jul 16	OCOP

**Appendix V**  
Oak Knoll Use of Tier 4  
Equipment during  
Construction

April 24, 2017

Heather Klein  
Supervising Planner  
City of Oakland  
250 Frank Ogawa Plaza, Room 3315  
Oakland, CA 94612

**Re: Oak Knoll Mixed Use Development Project and Construction  
Emissions: Use of Tier 4 Equipment**

Dear Heather:

Argent Management, LLC is a leading provider of real estate services to institutional investors, private owners, developers and financial institutions. We provide the full spectrum of development services, including construction design and management. Argent Management will be providing construction management services for the Oak Knoll Mixed Use Development Project.

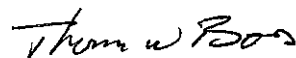
The City of Oakland requires all construction equipment used in development projects in Oakland to use Best Available Control Technology (BACT) to reduce construction-related emissions. The City interprets BACT in this context to mean use of Tier 4 equipment.

The Oak Knoll Mixed Use Development Project will and can comply with this requirement during construction. Tier 4 equipment has been available since 2011 and beginning in 2015, all new off-road vehicles sold in the United States have been required to be Tier 4 compliant. Tier 4 equipment is already routinely used at construction sites throughout California and is readily available. Argent Management has successfully overseen other projects where it was required to and did use exclusively Tier 4 construction equipment.

Construction of the Oak Knoll Project is anticipated to commence in 2018 and be complete in 2024. The percentage of Tier 4 equipment in use over time will only continue to expand. A requirement to use Tier 4 equipment for the construction of the Oak Knoll project is therefore feasible. This particularly true because Argent Management can draw from a large pool of companies when choosing its equipment supplier. Thus, if one supplier lacks a particular piece of equipment with a Tier 4 engine, Argent Management will be able to obtain it from a different supplier.

Please do not hesitate to contact me if you need any additional information.

Sincerely,



Tom Bors  
Senior Project Manager

# **Appendix W**

## Additional Information on Tier 4 Equipment Use and Effectiveness

# Memorandum

<b>Date:</b>	August 23, 2016
<b>To:</b>	Peterson Z. Vollmann, City of Oakland
<b>From:</b>	ICF International
<b>Subject:</b>	<b>226 13<sup>th</sup> Street Project – Response to Appeal from Adams Broadwell Joseph &amp; Cardozo</b>

This memorandum provides responses to the appeal filed by Adams Broadwell Joseph & Cardozo (hereafter, “Adams Broadwell Letter”) dated July 1, 2016, as well as the technical comments prepared by Matt Hagemann and Jessie Jaeger (hereafter, “SWAPE letter”) dated May 31, 2016, which were attached to that letter, regarding the Oakland Planning Commission’s June 22, 2016 decision to approve and adopt the CEQA findings for the 226 13<sup>th</sup> Street Project (PLN15-320). The responses are organized into the following topics, which correspond with the topics in the Adams Broadwell letter and the SWAPE letter:

- A) Consistency with the CEQA Addendum and Exemption Requirements
- B) Adequacy of the Project-Specific Health Risk from Diesel Particulate Matter (DPM) Analysis and Mitigation

## **A) Consistency with the CEQA Addendum and Exemption Requirements**

*Section A of the Adams Broadwell letter asserts that the City may not rely on previous environmental analysis for project approval. Specifically, the Adams Broadwell letter asserts that the project is not consistent with CEQA Addendum and Exemption requirements. Therefore, the project allegedly would result in new or more severe significant impacts than were analyzed in the Lake Merritt Station Area Plan Environmental Impact Report (LMSAP EIR).<sup>1</sup>*

**RESPONSE:** The LMSAP EIR analyzed the environmental impacts of the adoption and implementation of the LMSAP at full build out and provided project-level review for reasonably foreseeable development, such as the project. The City Council certified the LMSAP EIR in accordance with CEQA in November 2014. There was no CEQA lawsuit challenging the certification of the LMSAP EIR and the analysis now is presumptively valid under California law. Since that certification, the City has created and relied upon a framework for analyzing projects within the LMSAP area called “CEQA Analysis,” which separately and independently provides a basis for CEQA compliance. This framework relies on the following applicable streamlining/tying and addendum sections of CEQA:

---

<sup>1</sup> The City of Oakland (City) certified an EIR for the LMSAP in November 2014, pursuant to CEQA. The LMSAP EIR can be obtained from the City of Oakland Bureau of Planning at 250 Frank H. Ogawa Plaza, Suite 2114, Oakland, California 94612, and/or located at <http://www2.oaklandnet.com/Government/o/PBN/OurServices/Application/DOWD009157>.



construction of the proposed project would not result in significant health risk impacts with implementation of SCA A/SCA AIR-1, as outlined in the LMSAP EIR. Accordingly, the conclusions and mitigation of the CEQA Analysis are valid and do not represent substantial information showing a new or more severe impact than previously analyzed. Preparation of an EIR is therefore not warranted.

#### *4. Failure to Resolve Issues (related to Tier 4 engines)*

*The Adams Broadwell letter restates the conclusions of SWAPE's analysis and asserts the project would result in significant health risks, requires a quantitative HRA, and must implement all feasible mitigation to reduce DPM emissions.*

**RESPONSE:** As discussed above, the LMSAP EIR disclosed that construction-related health risks would be less than significant with implementation of construction-related best management practices identified in SCA A, which are found in SCA AIR-1 in Attachment A of the CEQA Analysis. Project construction would not result in a more severe impact than what was disclosed in the LMSAP EIR. Preparing an additional construction-related HRA would result in unnecessary and duplicative studies. Nevertheless, in the interest of being conservative, ICF prepared a detailed HRA to confirm that project construction would not result in significant health impacts. ICF's HRA is consistent with agency guidance, incorporates project-specific assumptions, and uses the AERMOD/HARP2 modeling platforms, and therefore represents a more refined and comprehensive assessment of potential health risks than SWAPE's HRA. The results of ICF's HRA are presented in Table 1. Since construction of the project would not result in significant health risk impacts with implementation of SCA AIR-1, no additional mitigation is required.

*The Adams Broadwell letter also questions the feasibility of requiring all Tier 4 equipment. The letter cites a white paper published by the California Industry Air Quality Coalition that indicates Tier 4 equipment are mostly new, and as such, argues that the City has failed to demonstrate that all construction equipment would have Tier 4 engines at the time of construction.*

Tier 4 equipment is routinely used at construction sites throughout California. Numerous CEQA documents have relied on mitigation for construction equipment to meet Tier 4 emission standards to reduce air quality impacts to a less-than-significant level. Several local governments and agencies have also adopted policies related to use of Tier 4 equipment. For example, the Los Angeles County Metropolitan Transportation Authority's Green Construction Policy requires "from January 1, 2015 and onwards" that "all off-road diesel-powered construction equipment greater than 50 hp shall meet Tier-4 off-road emission standards at a minimum."<sup>3</sup>

While mitigation requiring the use of Tier 4 equipment is becoming commonplace, in response to SWAPE's concern regarding commercial availability, ICF compiled data on recent sales of construction equipment. Beginning in 2015, all new offroad engines sold in the United States are required to be Tier 4-compliant. Therefore, the availability of Tier 4 equipment should be reflected in equipment sales over time, particularly during the phase-in period (2011-2014) and after the 2015 compliance date. If Tier 4 equipment is not commercially available, or are not being purchased, new equipment sales during and after the Tier 4 phase-in period would be less than sales trends over time. Increasing sales of *used* equipment during the same time period may also indicate potential limited availability of Tier 4 equipment; such an increase in demand for used equipment could induce owners of older equipment to sell earlier than they otherwise would have sold. On the

---

<sup>3</sup> See [http://media.metro.net/projects\\_studies/sustainability/images/Green\\_Construction\\_Policy.pdf](http://media.metro.net/projects_studies/sustainability/images/Green_Construction_Policy.pdf).

other hand, if Tier 4 equipment is commercially available and readily being purchased, *new* equipment sales during and after the Tier 4 phase-in period should largely reflect historic sales trends.

Figure 1 summarizes sales data for offroad equipment in the United States between 2011 and 2016. While there is some month-to-month variation, sales of both used equipment have remained relatively constant, while sales of new equipment have slightly increased since 2011. The following discussion provides sales data for each of the equipment types included in the project construction inventory.

#### Forklifts

North American forklift sales increased from 98,000 units in 2009 to 214,000 in 2014. An estimated 220,000 units were sold in 2015 and a projected 240,000 units were sold in 2016.<sup>4</sup> Because the phase-in of Tier 4 engines was complete at the end of 2014, and all new equipment sold in 2015 or later must be Tier 4-compliant, these sales data suggest that Tier 4 forklifts are being purchased.

#### Excavators

Figure 2 shows sales of excavators between 2006 and 2015. Sales of new excavators rose steadily during the Tier 4 phase-in period (2011-2014) and continued to increase in 2015. Sales of used excavators also increased, but at a more modest pace. There was no decline in sales with the introduction of Tier 4 excavators, and no steepening of the used sales trend that could suggest that buyers were purchasing older (i.e., Tier 3 and earlier) equipment in place of new Tier 4 excavators.

#### Loaders

Figure 3 shows sales of wheel loaders between 2006 and 2015. Sales of new wheel loaders rose steadily during the Tier 4 phase-in period (2011-2014) and continued to increase in 2015. Sales of used loaders also increased, but at a more modest pace. There was no decline in sales with the introduction of Tier 4 loaders, and no steepening of the used sales trend that could suggest that buyers were purchasing older (i.e., Tier 3 and earlier) equipment rather than new Tier 4 loaders.

#### Generators and Drill Rigs

No sales data were available for generators or drill rigs. However, sales trends for these equipment types are expected to be consistent with trends for forklifts, excavators, and loaders, given overall market trends (see Figure 1).

The sales data collected by ICF demonstrate that Tier 4 equipment are being purchased and that sales of new equipment have not declined with the Tier 4 compliance requirements. Therefore, Tier 4 equipment is commercially available and can feasibly be required by the City to reduce construction-related DPM.

*The Adams Broadwell letter also asserts that, without a condition in SCA AIR-1 that specifically requires all Tier 4 engines, the City cannot rely on SCA AIR-1 to conclude construction health risks would be less than significant.*

---

<sup>4</sup> Manfredi 2014. Frank Manfredi. 2014 Construction Machinery Forecast. In: Equipment Today. January 6. Available: <http://www.forconstructionpros.com/article/11271548/2014-construction-forecast-and-equipment-acquisition-trends>. Accessed: July 29, 2016.

As noted above, subsection (w) of SCA AIR-1 requires that equipment and diesel trucks be equipped with Best Available Control Technology. Tier 4 engines are considered the best available technology. Thus, the City can rely on SCA AIR-1 to ensure that construction health risks would be less than significant.

**TABLE 1**  
**PROJECT-LEVEL CANCER AND CHRONIC (HI) RISKS AND PM2.5 CONCENTRATIONS DURING CONSTRUCTION<sup>a</sup>**

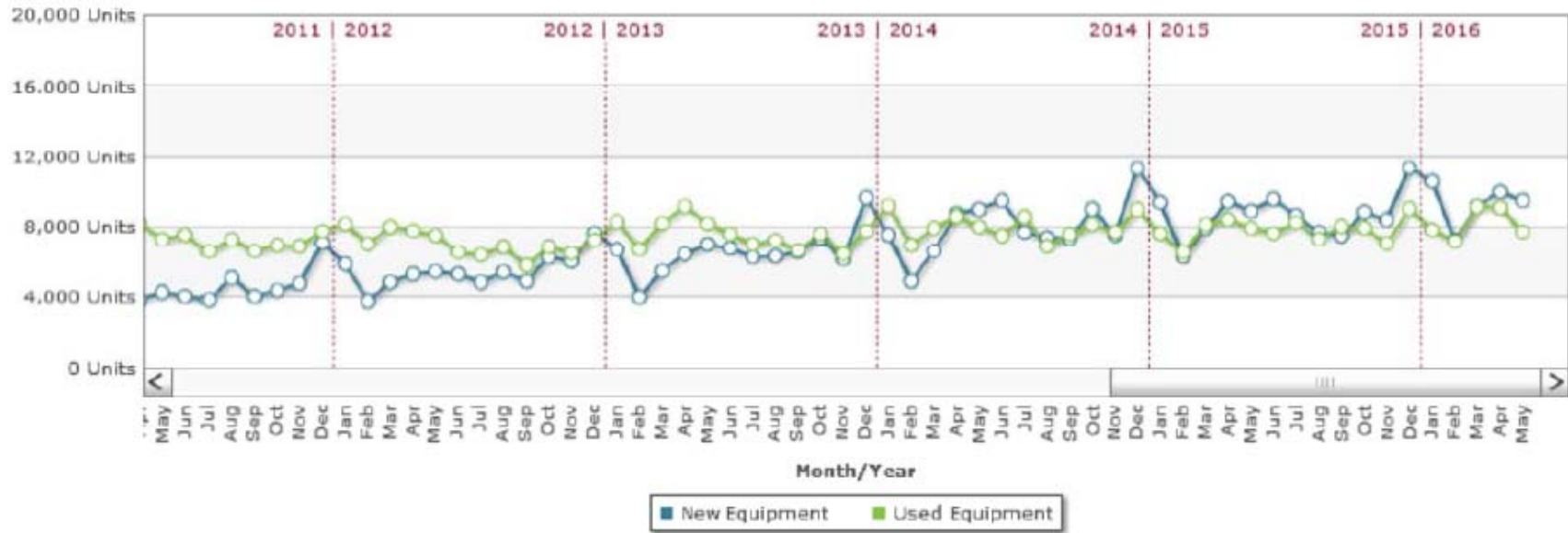
Receptor Type	Chronic Non-Cancer HI	Project-Level Incremental Cancer Risk (per million)	Project-Level PM2.5 Concentration ( $\mu\text{g}/\text{m}^3$ )
Residential	<0.01	3.18	0.04
Daycare/Pre-School <sup>b</sup>	<0.01	0.25	0.02
School <sup>c</sup>	<0.01	0.07	0.01
Park/Recreational Facility	<0.01	0.01	<0.01
BAAQMD Thresholds	1.0	10	0.3

<sup>a</sup> Assumes implementation of SCA AIR-1 (see Attachment A to this memorandum). Consistent with BAAQMD and OEHHA guidance, the results represent the worst case predicted health risk for the modeled receptors.

<sup>b</sup> Includes churches. Per BAAQMD guidance, uses 8-hour moderate intensity breathing rates.

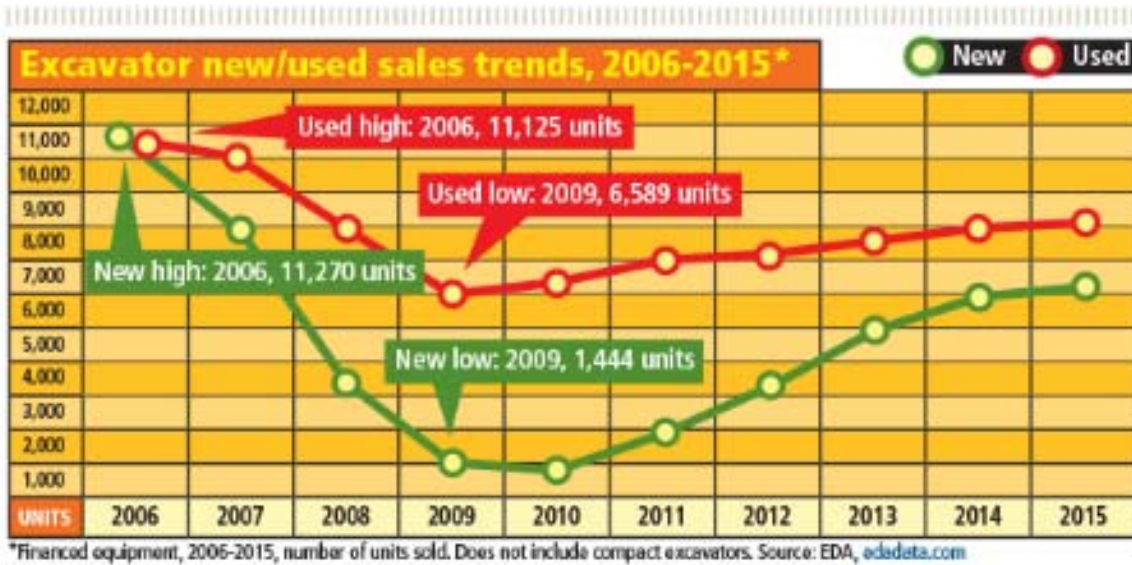
<sup>c</sup> Includes elementary schools, high schools, and charter schools. Per BAAQMD guidance, uses 8-hour moderate intensity breathing rates.

**FIGURE 1**  
**UNITED STATES CONSTRUCTION EQUIPMENT SALES (2000-2016)<sup>5</sup>**



<sup>5</sup> EDAdata 2016. EDA. Industry Insight. Available: <http://www.edadata.com/resources/industrysight/construction.aspx>. Accessed: July 29, 2016.

FIGURE 2  
 UNITED STATES EXCAVATOR EQUIPMENT SALES (2006-2015)<sup>6</sup>



<sup>6</sup> Equipment World 2016. Equipment World. Infographic: Excavator sales and buyer trends. Available: <http://www.equipmentworld.com/infographic-excavator-sales-and-buyer-trends>. Accessed: July 29, 2016.

FIGURE 3  
 UNITED STATES WHEEL LOADER EQUIPMENT SALES (2006-2015)<sup>7</sup>



\* financed equipment, 2006-2015, number of units sold. Includes toolcarriers. Source: EDA, edadata.com

<sup>7</sup> Equipment World 2016. Equipment World. Infographic: Wheel loader sales and buyer trends. Available: <http://www.equipmentworld.com/infographic-wheel-loader-sales-and-buyer-trends>. Accessed: July 29, 2016.

# Attachment A. Project Construction Emission Inventory

**TABLE A-1**  
**EMISSIONS FROM CONSTRUCTION WITH IMPLEMENTATION OF SCA AIR-1 (AVERAGE LBS PER DAY)<sup>a, b</sup>**

Construction Year (phase)	ROG	NO <sub>x</sub>	CO	PM10	PM2.5
<b>Project</b>					
Average Daily Construction Emissions	8.4	3.0	24.3	17.8	4.5
City of Oakland Thresholds	54	54	-	82	54
<b>Significant (Yes or No)?</b>	<b>No</b>	<b>No</b>	<b>-</b>	<b>No</b>	<b>No</b>

<sup>a</sup> Emissions are average daily pounds per day during the project's anticipated approximate 24-month construction period, which includes 521 working days.

<sup>b</sup> Emissions include implementation of SCA AIR-1, subsections (k) watering, and (w) Tier 4 engines. The modeling applies a 69 percent reduction to PM10 and PM2.5 dust during active grading, per the Western Regional Air Partnership Fugitive Dust Handbook. (Available: [http://www.wrapair.org/forums/dejt/fdh/content/FDHandbook\\_Rev\\_06.pdf](http://www.wrapair.org/forums/dejt/fdh/content/FDHandbook_Rev_06.pdf)). ROG, NO<sub>x</sub>, CO, PM10, and PM2.5 exhaust emissions are based on Tier 4 emission rates, per CalEEMod. All off-road and on-road diesel vehicles were also assumed to use diesel HPR. Reductions achieved with use of diesel HPR are based on the National Renewable Energy Laboratory's February 2012 test summary report. (Available at: [http://dieselhpr.com/assets/media/DieselHPR\\_Fuel\\_Specification.pdf](http://dieselhpr.com/assets/media/DieselHPR_Fuel_Specification.pdf)). Other strategies outlined under SCA-AIR-1 would further reduce emissions beyond those reported in this table. Reductions were not quantified for these strategies since they are either implemented as feasible or may overlap with reductions estimated for subsections (k) and (w).



**Attachment B.** June 22, 2016 Response to the Comment  
Letter from Adams Broadwell Joseph & Cardozo dated  
May 31, 2016

---