

| | |
|--------------------------------------|---|
| Location: | Utility Pole in the Public Right of Way adjacent to 66 Lake Merritt Boulevard: |
| Assessor's Parcel Number(s): | 002-0091-001-00; The site is located northwest of the parcel at 66 Lake Merritt Blvd. |
| Proposal: | Installation of a "small cell" wireless Telecommunication Facility on an existing 25' tall City Light Pole located in the public right-of-way. The project involves installation of one (1) antenna measuring 24.7" long and 10" in diameter within shroud at a height of 28'-6"; two (2) radio units (18" tall, 7.88" wide and 4.13" deep) and a meter box at a height of 10' and 11'-3" above ground. |
| Applicant | Vinculums Services for AT&T Wireless |
| Contact Person/ Phone Number: | Justin Giarritta / (707) 225-2865 |
| Owner: | City of Oakland |
| Case File Number: | PLN19065 |
| Planning Permits Required: | Major Conditional Use Permit and Major Design Review to install a Monopole Telecommunication Facility on an existing City light pole located in the public right -of- way within 300 feet of a residential zone. |
| General Plan: | Central Business District |
| Zoning: | Lake Merritt Station Area District Mixed - 4 Commercial Zone |
| Environmental Determination: | Exempt per Section 15301 of the State CEQA Guidelines, minor additions and alterations to existing city light poles; Section 15303, new construction or conversion of small structures; and Section 15183, projects consistent with a community plan, general plan or zoning. |
| Historic Status: | No Historic Record – Utility Pole |
| City Council District: | 2 |
| Date Filed: | March 26, 2019 |
| Action to be Taken: | Decision based on staff report |
| Finality of Decision: | <i>Appealable to City Council within 10 days</i> |
| For Further Information: | Contact case planner Heather Klein, Planner IV at (510) 238-3659 or hklein@oaklandca.gov |

SUMMARY

The project applicant (Vinculums Services) is proposing to establish a "small cell" wireless telecommunication facility site for AT&T Wireless on an existing 25' City street light pole located in the public right-of-way. The project involves installation of one (1) antenna measuring 24.7" long and 10" in diameter within shroud at a height of 28'-6"; two (2) radio units (18" tall, 7.88" wide and 4.13" deep) and a meter box at a height of 10' and 11'-3" above ground. The purpose of the installations is to enhance existing wireless services within this vicinity.

A Major Conditional Use Permit and Design Review permit is required for the installation of a new Monopole Telecommunications Facility within 300' of a residential zone. The antenna shrouds and associated equipment will be painted to match the City light poles. As result, the proposed Telecommunication Facility is in an appropriate location and would not significantly increase negative visual impacts to adjacent neighboring properties. The project meets all the required findings for approval of the project.

CITY OF OAKLAND PLANNING COMMISSION

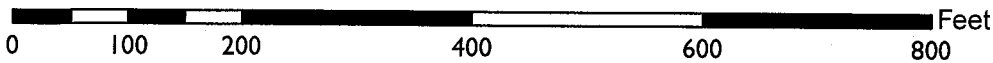
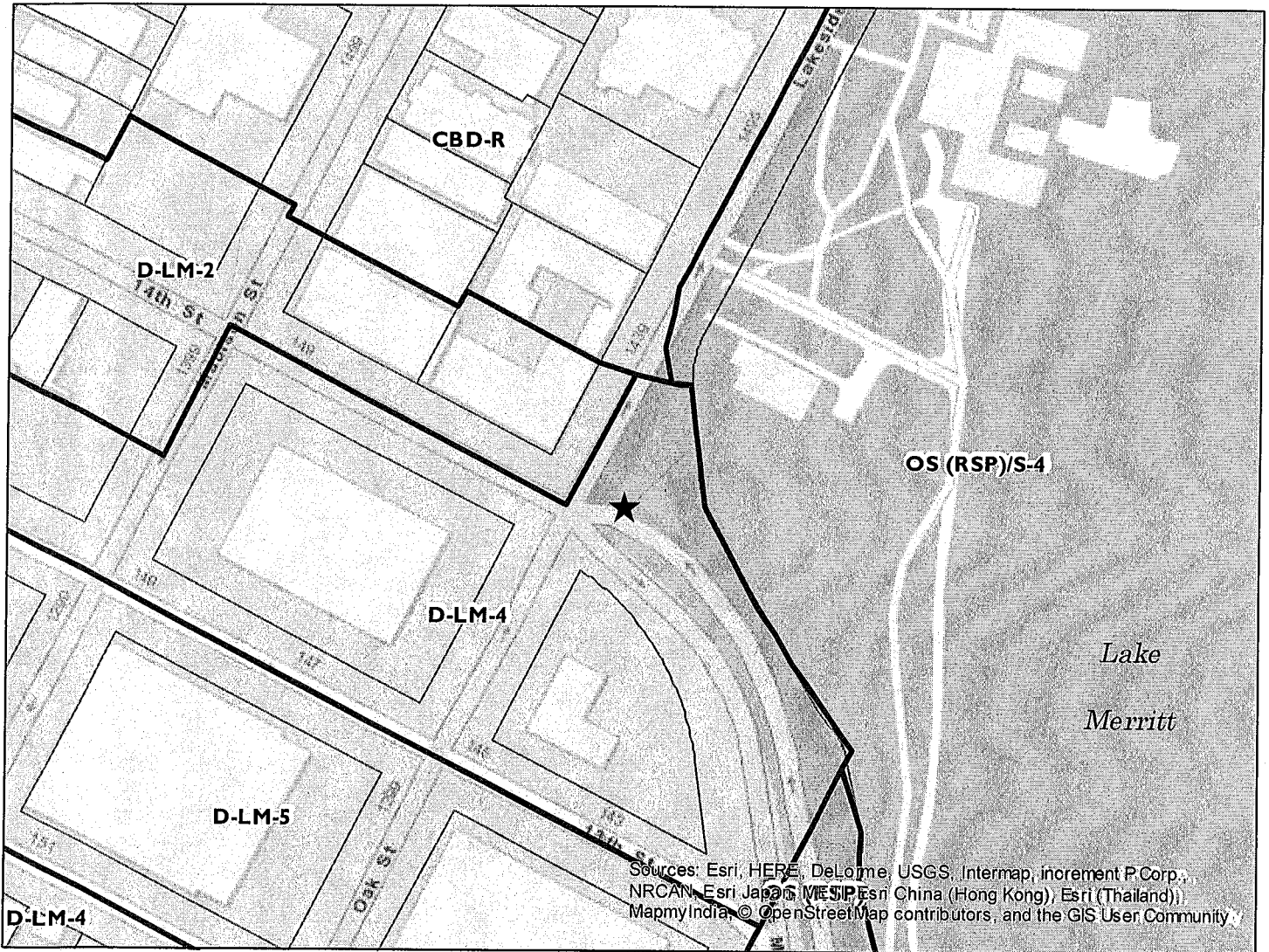

Case File: PLN19065
Applicant: Vinculums Services for AT&T Wireless
Address: The Public Right of Way adjacent to 66 Lake Merritt Boulevard
Zone: DL-LM-4

BACKGROUND

For several years in the City of Oakland, telecommunications carriers have proposed facility installations within the public right-of-way, instead of private property. These facilities typically consist of antennas and associated equipment attached to utility poles or street light poles. Poles are often replaced with replicas for technical purposes. The main purpose of the installation is to enhance existing service, given increasing technological demands for bandwidth, through new technology and locational advantages. For City light poles, projects also require review by the City's Public Works Agency (PWA) and Real Estate Division and involve other considerations such as impacts to historical poles. The PWA may also review projects involving street lights.

Several projects for new DAS (distributed antenna services) facilities have come before the Planning Commission for a decision and have been installed throughout the City. Some applications have been denied due to view obstructions or proximity to residences. Improved practices for the processing of all types of sites have been developed as a result, with conditions of approval typically attached such as painting and texturing of approved components to more closely match utility poles in appearance. Approvals do not apply to any replacement project should the poles be removed for any reason. As with sites located on private property, the Federal Government precludes cities from denying an application on the basis of emissions concerns if a satisfactory emissions report is submitted. More recent Federal changes have streamlined the process to service existing facilities.

Currently, telecommunications carriers are in the process of attempting to deploy "small cell sites." These projects also involve attachment of antennas and equipment at public right-of-way facilities such as poles or lights for further enhancement of services. However, components are now somewhat smaller in size than in the past. Also, sites tend to be in "flat land" neighborhoods and urban/commercial corridor where view obstructions are less likely to be an issue. Good design and placement are given full consideration nonetheless, especially with the greater presence of historic structures in Downtown.

TELECOMMUNICATIONS BACKGROUND

Limitations on Local Government Zoning Authority under the Telecommunications Act of 1996

Section 704 of the Telecommunications Act of 1996 (TCA) provides federal standards for the siting of "Personal Wireless Services Facilities." "Personal Wireless Services" include all commercial mobile services (including personal communications services (PCS), cellular radio mobile services, and paging); unlicensed wireless services; and common carrier wireless exchange access services. Under Section 704, local zoning authority over personal wireless services is preserved such that the FCC is prevented from preempting local land use decisions; however, local government zoning decisions are still restricted by several provisions of federal law. Specifically:

- Under Section 253 of the TCA, no state or local regulation or other legal requirement can prohibit or have the effect of prohibiting the ability of any entity to provide any interstate or intrastate telecommunications service.
- Further, Section 704 of the TCA imposes limitations on what local and state governments can do. Section 704 prohibits any state and local government action which unreasonably discriminates among personal wireless providers. Local governments must ensure that its wireless ordinance does not contain requirements in the form of regulatory terms or fees which may have the "effect" of prohibiting the placement, construction, or modification of personal wireless services.
- Section 704 also preempts any local zoning regulation purporting to regulate the placement, construction and modification of personal wireless service facilities on the basis, either directly or indirectly, on the environmental effects of radio frequency emissions (RF) of such facilities, which

otherwise comply with Federal Communications Commission (FCC) standards in this regard. (See 47 U.S.C. Section 332(c)(7)(B)(iv) (1996)). This means that local authorities may not regulate the siting or construction of personal wireless facilities based on RF standards that are more stringent than those promulgated by the FCC.

- Section 704 mandates that local governments act upon personal wireless service facility siting applications to place, construct, or modify a facility within a reasonable time (See 47 U.S.C.332(c)(7)(B)(ii) and FCC Shot Clock ruling setting forth “reasonable time” standards for applications deemed complete).
- Section 704 also mandates that the FCC provide technical support to local governments in order to encourage them to make property, rights-of-way, and easements under their jurisdiction available for the placement of new spectrum-based telecommunications services.

For more information on the FCC’s jurisdiction in this area, consult the following:

Competition & Infrastructure Policy Division (CIPD) of the Wireless Telecommunications Bureau, main division number: **(202) 418-1310**. <https://www.fcc.gov/general/competition-infrastructure-policy-division-wireless-telecommunications-bureau>

SITE DESCRIPTION

The project site consists of an existing non-decorative City street light pole located in a landscaped strip in the sidewalk at the northwest corner of 66 Lake Merritt Boulevard near the. To the north and east of the project site is the Cameron -Stanford House in Lake Merritt Park and Lake Merritt; to the south is the Oakland Public Library and the Alameda County Courthouse; and to the west is a 12-story office building. The existing metal City street -light pole measures twenty-five (25’) feet in height.

PROJECT DESCRIPTION

The project applicant proposes to install a Monopole Telecommunications Facility (“small cell site”) on an existing, street light pole located in the public right-of-way (Attachment C). The project involves installation of:

- One (1) antenna measuring 24.7” long and 10” in diameter within shroud at a height of 28’-6”;
- Two (2) radio units (18” tall, 7.88” wide and 4.13” deep) mounted 11’-3” above the ground; and
- A meter box mounted at a height of 10’ above the ground.

The purpose of the installations is to enhance existing wireless services within this vicinity.

GENERAL PLAN ANALYSIS

The subject property is located within the Central Business District land use classification per the Oakland General Plan’s Land Use and Transportation Element (LUTE). The Central Business District is intended to encourage, support, and enhance the downtown area as a high density mixed-use urban center of regional importance and primary hub for business, communications, office, government, high technology, retail, entertainment, and transportation in northern California. The proposed antenna will be within a shroud, mounted on top of the City light utility pole. The proposed antenna and related equipment are compatible with the typical utilities located on City light poles and will facilitate communication and technology in the downtown area. As a result, the proposal is an appropriate location and would not significantly increase negative visual impacts to adjacent neighboring commercial, civic and residential properties.

Given increasing reliance upon cellular service for phone and internet, the proposal for a Monopole Telecommunications Facility will not adversely affect and detract from the characteristics of the neighborhood given the surrounding civic and government uses. The proposal is consistent and supports the intent to make to the downtown a center for regional importance, a hub for businesses, communications and technology. Staff therefore finds the proposal, as conditioned, to conform to the General Plan.

ZONING ANALYSIS

The subject properties are in Lake Merritt Station Area District Mixed - 4 Commercial Zone (D-LM-4 Zone). The intent of the D-LM-4 Zone is to designate areas of the Lake Merritt Station Area Plan District appropriate for a wide range of Residential, Commercial, and compatible Light Industrial Activities.

The facility is located a little over 100' from the CBD-R Central Business District Residential Zone to the north. Section 17.35.40 of the City of Oakland Planning Code requires a Conditional Use Permit to install a Monopole Telecommunication facility. Furthermore, pursuant to Section 17.134.020 (A) (3)(i), a Major Conditional Use Permit is required for any telecommunication facility in or within 300' of the boundary of any residential zone.

Monopole Telecommunications Facilities on City light poles require a Major Conditional Use Permit and a Regular Design Review with additional findings; these permits are decided by the Planning Commission for sites located within 300' of a residential zone. New wireless telecommunications facilities may also be subject to a Site Alternatives Analysis, Site Design Alternatives Analysis, and a satisfactory radio-frequency (RF) emissions report.

Staff analyzed the proposal in consideration of these requirements in the 'Key Issues and Impacts' section of this report. Additionally, attachment to City infrastructure requires review by the City's Real Estate Department, Public Works Agency's Electrical Division, and Information Technology Department. Given customers increasing reliance upon cellular service for phone and Wi-Fi and that the Monopole Telecommunications Facility is adjacent to the residential and commercial buildings, therefore, the proposal conforms to this intent of the zoning.

ENVIRONMENTAL DETERMINATION

The California Environmental Quality Act (CEQA) Guidelines categorically exempts specific types of projects from environmental review. Staff found that the project was consistent with CEQA Guidelines Section 15301, projects involving 'Existing Facilities', Section 15303, projects involving 'Construction of Small Structures and Section 15183, as a project consistent with a community plan, general plan or zoning. Each CEQA exemption provides a separate and independent basis that the project is exempt from environmental review.

The Class 01 exemption (Section 15301) consists of the operation, repair, maintenance, permitting, leasing, licensing, or minor alteration of existing public or private structures, facilities, mechanical equipment, or topographical features, involving negligible or no expansion of use beyond that existing at the time of the lead agency's determination. The project meets this exemption as the City light pole is already used for utility purposes, and the proposal includes the addition of minor mechanical equipment on the pole.

The Class 03 exemption (Section 15303) consists of construction and location of limited numbers of new, small facilities or structures; installation of small new equipment and facilities in small structures; and the conversion of existing small structures from one use to another where only minor modifications are made in the exterior of the structure. The project meets this exemption as the City light pole is already used for utility purposes and the proposal includes the addition of minor mechanical equipment on the pole in small structures.

Staff received a comment letter challenging staff's use of a CEQA exemption because the commenter believes there may be an impact on wildlife as the project is located near Lake Merritt Park. Staff reviewed the comments and responds below.

First, the letter and study provided by the public is related to environmental review conducted under the National Environmental Policy Act (NEPA) which is generally used for projects requiring federal approval. NEPA has different thresholds than CEQA does for conducting environmental review and evaluating projects. Even if a federal approval was needed, the FCC recently exempted small wireless facilities from NEPA review.

Furthermore, the letter and study discuss the effects of communication towers. Specifically,

“the Department recommends revisions to the proposed procedures to better reflect the impacts to resources under our jurisdiction from communication towers. The placement and operation of communication towers, including un-guyed, unlit, monopole or lattice-designed structures, impact protected migratory birds in two significant ways. The first is by injury, crippling loss, and death from collisions with towers and their supporting guy-wire infrastructure, where present. The second significant issue associated with communication towers involves impacts from non-ionizing electromagnetic radiation emitted by them.”

The project does not involve a communication tower, guy-wire infrastructure, or the type of emissions of a “small cell” wireless facility. As such, this letter and study is not accurate comparison to the project.

Second, as noted above, Section 704 preempts any local zoning regulation purporting to regulate the placement, construction and modification of personal wireless service facilities on the basis, either directly or indirectly, on the environmental effects of radio frequency emissions (RF) of such facilities either on humans or wildlife. The issues brought up by the commenter are related to health and emissions.

Third, the project doesn't trigger any of the exceptions in CEQA Section 15300.2 that would disqualify it for an exemption.

- The location standard only applies to Class 03 exemptions not Class 01 exemptions. While, Lake Merritt Park is a sensitive environment as a National Wildlife Refuge, the utility pole is not sensitive, and these are located throughout Oakland including City parks. Furthermore, the small wireless facility's height and size are well within the definitions of small wireless facilities, which are traditionally seen as exempt from environmental review.
- The project would not result in a cumulative impact of successive projects of the same type and the same place being significant. The City light pole is existing, and the placement of the small wireless facility is exempt from CEQA, and by their nature do not result in the potential for a significant impact, either individually or cumulatively.
- The project will not result in the reasonable possibility that the activity and changes will have a significant effect due to unusual circumstances. Again, the facility is existing and there is no unusual circumstance. Small wireless facilities have been approved all over the City and in City parks where birds and other wildlife are located.
- The City light pole is not located near a scenic highway or on a hazardous waste site.
- The City light pole is not historic.

Finally, Section 15183 does not include standards which preclude its use. As noted above, this project is also consistent with the City's General Plan and Zoning subject to Conditional Use Permit and Regular Design Review approval, consistent with CEQA Section 15183. Again, the use of this Section provides a separate and independent basis from the use of Sections 15301 and 15303 that the project is exempt from environmental review. While the commenter notes several policies in the Open Space, Conservation and

Recreation Element of the General Plan related to wildlife, these policies address loss of habitat, corridors, and urbanization. The City pole is existing, no habitat will be removed with the proposal, and the City has already taken steps to address migratory corridors through Lake Merritt's designation as a Wildlife Refuge. Finally, it should also be noted that the General Plan contains many policies, which may in some cases address different goals, and thus some policies may compete with each other. The Planning Commission, in deciding whether to approve the proposed project, must decide whether, on balance, the project is consistent (i.e., in general harmony) with the General Plan.

KEY ISSUES AND IMPACTS

The proposal to establish a Monopole Telecommunications Facility is subject to the following Planning Code development standards, which are followed by staff's analysis in relation to this application:

17.128.080 Monopole Telecommunications Facilities.

A. General Development Standards for Monopole Telecommunications Facilities.

1. Applicant and owner shall allow other future wireless communications companies including public and quasi-public agencies using similar technology to collocate antenna equipment and facilities on the monopole unless specific technical or other constraints, subject to independent verification, at the applicant's expense, at the discretion of the City of Oakland Zoning Manager, prohibit said collocation. Applicant and other wireless carriers shall provide a mechanism for the construction and maintenance of shared facilities and infrastructure and shall provide for equitable sharing of cost in accordance with industry standards. Construction of future facilities shall not interrupt or interfere with the continuous operation of applicant's facilities.

The proposal involves use of an existing City street light pole that would remain available for future collocation purposes as practicable.

2. The equipment shelter, or cabinet must be concealed from public view or made compatible with the architecture of the surrounding structures or placed underground. The shelter or cabinet must be regularly maintained.

Recommended conditions of approval require painting and texturing the antenna and equipment to match the appearance of the metal pole. There is no equipment shelter or cabinet proposed; however, minimal equipment (meter box) would be closely mounted onto the side of the metal pole.

3. When a monopole is in a Residential Zone or adjacent to a residential use, it must be set back from the nearest residential lot line a distance at least equal to its total height.

This standard is not applicable. The existing light pole is located within a landscape strip in the sidewalk. The proposed project is not within a residential zone, but adjacent to civic, commercial and open space uses.

4. In all zones other than the D-CE-5, D-CE-6, IG, CIX-2, and IO Zones, the maximum height of Monopole Telecommunications Facilities and connecting appurtenances may be increased from the otherwise required maximum height to forty-five (45) feet upon the granting of a Conditional Use Permit (see Chapter 17.134 for the Conditional Use Permit Procedure).

This standard does not apply. The subject property is not located in any of the described zoning districts. Nonetheless, the facility would not exceed a height of 28'-6".

5. In the D-CE-5, D-CE-6, CIX-2, and IO Zones, the maximum height of Monopole Telecommunications Facilities and connecting appurtenances may be increased from the otherwise required maximum height to eighty (80) feet upon the granting of a Conditional Use Permit (see

Chapter 17.134 for the Conditional Use Permit Procedure).

This standard does not apply. The subject property is not located in any of the described zoning districts. Nonetheless, the facility would not exceed a height of 28'-6".

6. In the IG Zone, the maximum height of Monopole Telecommunications Facilities and connecting appurtenances may reach a height of forty-five (45) feet. These facilities may reach a height of eighty (80) feet upon the granting of Regular Design Review approval (see Chapter 17.136 for the Design Review Procedure).

This standard does not apply. The subject property is not located in any of the described zoning districts. Nonetheless, the facility would not exceed a height of 28'-6".

7. The applicant shall submit written documentation demonstrating that the emissions from the proposed project are within the limits set by the Federal Communications Commission.

This standard is met by the proposal; a satisfactory emissions report has been submitted and is attached to this report (Attachment F).

8. Antennas may not extend more than fifteen (15) feet above their supporting structure.

The proposed antenna would project less than fifteen feet above the City light pole.

17.128.110 Site location preferences.

New wireless facilities shall generally be located on the following properties or facilities in order of preference:

- A. Co-located on an existing structure or facility with existing wireless antennas.**
- B. City-owned properties or other public or quasi-public facilities.**
- C. Existing commercial or industrial structures in Nonresidential Zones (excluding all HBX Zones and the D-CE-3 and D-CE-4 Zones).**
- D. Existing commercial or industrial structures in Residential Zones, HBX Zones, or the DCE-3 or D-CE-4 Zones.**
- E. Other Nonresidential uses in Residential Zones, HBX Zones, or the D-CE-3 or D-CE-4 Zones.**
- F. Residential uses in Nonresidential Zones (excluding all HBX Zones and the D-CE-3 and D-CE-4 Zones).**
- G. Residential uses in Residential Zones, HBX Zones, or the D-CE-3 or D-CE-4 Zones.**

Facilities locating on an A, B or C ranked preference do not require a site alternatives analysis. Facilities proposing to locate on a D through G ranked preference, inclusive, must submit a site alternatives analysis as part of the required application materials. A site alternatives analysis shall, at a minimum, consist of:

- a. The identification of all A, B and C ranked preference sites within one thousand (1,000) feet of the proposed location. If more than two (2) sites in each preference order exist, the two such closest to the proposed location shall be required.*
- b. Written evidence indicating why each such identified alternative cannot be used. Such evidence shall be in sufficient detail that independent verification, at the applicant's expense, could be obtained if required by the City of Oakland Zoning Manager. Evidence should indicate if the reason an alternative was rejected was technical (e.g. incorrect height, interference from existing RF sources, inability to cover required area) or for other concerns (e.g. refusal to lease, inability*

to provide utilities).

A site alternatives analysis is not required because the proposal conforms to 'B' as it would be located on a public facility (City light pole). Nonetheless, the applicant has submitted an analysis which is attached to this report (Attachment E).

17.128.120 Site design preferences.

New wireless facilities shall generally be designed in the following order of preference:

- A. Building or structure mounted antennas completely concealed from view.**
- B. Building or structure mounted antennas set back from roof edge, not visible from public right-of way.**
- C. Building or structure mounted antennas below roof line (facade mount, pole mount) visible from public right-of-way, painted to match existing structure.**
- D. Building or structure mounted antennas above roof line visible from public right-of-way.**
- E. Monopoles.**
- F. Towers.**

Facilities designed to meet an A or B ranked preference do not require a site design alternatives analysis. Facilities designed to meet a C through F ranked preference, inclusive, must submit a site design alternatives analysis as part of the required application materials. A site design alternatives analysis shall, at a minimum, consist of:

- a. Written evidence indicating why each such higher preference design alternative cannot be used. Such evidence shall be in sufficient detail that independent verification could be obtained if required by the City of Oakland Zoning Manager. Evidence should indicate if the reason an alternative was rejected was technical (e.g. incorrect height, interference from existing RF sources, inability to cover required area) or for other concerns (e.g. inability to provide utilities, construction or structural impediments).*

The proposal most closely conforms to 'E' (monopole), and the applicant has submitted a satisfactory site design alternatives analysis (Attachment E).

17.128.130 Radio frequency emissions standards.

The applicant for all wireless facilities, including requests for modifications to existing facilities, shall submit the following verifications:

- a. With the initial application, a RF emissions report, prepared by a licensed professional engineer or other expert, indicating that the proposed site will operate within the current acceptable thresholds as established by the Federal government or any such agency who may be subsequently authorized to establish such standards.
- b. Prior to commencement of construction, a RF emissions report indicating the baseline RF emissions condition at the proposed site.
- c. Prior to final building permit sign off, an RF emissions report indicating that the site is actually operating within the acceptable thresholds as established by the Federal government or any such agency who may be subsequently authorized to establish such standards.

A satisfactory report is attached to this report (Attachment F).

Analysis

The proposed project would not be situated on an historic or decorative pole or structure, would not create a view obstruction. Staff, therefore, finds the proposal to provide an essential service with a least-intrusive possible design. The proposal, when viewed from the park will “blend in” with the existing tall evergreen trees across the street. Draft conditions of approval stipulate that the components be painted and textured to match the metal pole in appearance for camouflaging.

CONCLUSION

The proposed project meets all the required findings for approval. The proposal will provide an essential telecommunication service to the community and the City of Oakland at large and is consistent with the intent of the Central Business District’s intended uses and businesses. It will also be available to emergency services such as police, fire department and emergency response teams. Staff believes that the proposal is designed to meet the established zoning and telecommunication regulations and recommends supporting the Major Conditional Use Permit and Design Review application.

RECOMMENDATIONS:

1. Affirm staff's environmental determination.
2. Approve the Major Conditional Use Permit and Regular Design Review, subject to the attached Findings and Conditions of Approval.

Prepared by:

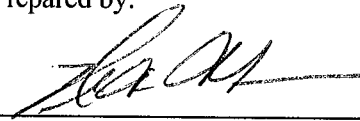

Heather Klein
Planner IV

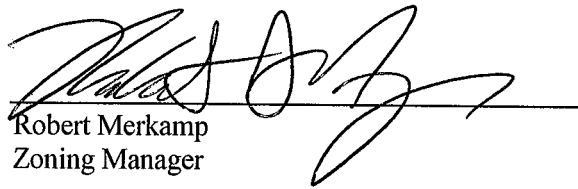

Robert Merkamp
Zoning Manager

Approved for forwarding to the
City Planning Commission:

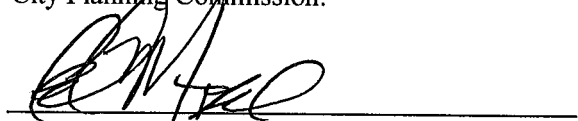

Ed Manasse, Interim Director
Bureau of Planning and Building

ATTACHMENTS:

- A. Findings
- B. Conditions of Approval
- C. Plans
- D. Photo-simulations
- E. Site/Site Design Alternatives Analysis
- F. RF Emissions Report
- G. CPUC Compliance Letter
- H. Proof of public notification posting
- I. Public comments received by date of packet preparation

ATTACHMENT A: FINDINGS

This proposal meets the required findings under General Use Permit Criteria (OMC Sec. 17.134.050), Conditional Use Permit Criteria for Monopole Facilities (OMC Sec. 17.136.040 (A)), Regular Design Review Criteria for Nonresidential Facilities (OMC Sec. 17.136.050(B)), Design Review Criteria for Monopole Telecommunications Facilities (OMC Sec. 17.128.070(B)), as set forth below. Required findings are shown in bold type; explanations as to why these findings can be made are in normal type.

GENERAL USE PERMIT CRITERIA (OMC SEC. 17.134.050):

A. That the location, size, design, and operating characteristics of the proposed development will be compatible with and will not adversely affect the livability or appropriate development of abutting properties and the surrounding neighborhood, with consideration to be given to harmony in scale, bulk, coverage, and density; to the availability of civic facilities and utilities; to harmful effect, if any, upon desirable neighborhood character; to the generation of traffic and the capacity of surrounding streets; and to any other relevant impact of the development.

The proposal is to establish a Monopole Telecommunications Facility in D-LM-4 Zone by attaching an antenna and related equipment to an existing City light pole. Attachment to an existing structure with the smallest possible components, painted and texturized to match the light pole, will be the least intrusive design. The project will enhance existing service for businesses, civic and open space users in the area.

B. That the location, design, and site planning of the proposed development will provide a convenient and functional living, working, shopping, or civic environment, and will be as attractive as the nature of the use and its location and setting warrant.

Attachment of a telecommunication facility to an existing City light pole structure with the smallest possible components, painted and texturized, to match the pole will be the least intrusive design.

C. That the proposed development will enhance the successful operation of the surrounding area in its basic community functions or will provide an essential service to the community or region.

The project will enhance existing service for businesses, civic and open space users in the area. The proposal is consistent and supports the intent to make to the downtown a center for regional importance, a hub for businesses, communications and technology.

D. That the proposal conforms to all applicable design review criteria set forth in the design review procedure at Section 17.136.070.

The proposal conforms to Design Review findings which are included below.

E. That the proposal conforms in all significant respects with the Oakland Comprehensive Plan and with any other applicable plan or development control map which has been adopted by the City Council.

The subject property is located within the Central Business District land use classification per the Oakland General Plan's Land Use and Transportation Element (LUTE). The Central Business District is intended to encourage, support, and enhance the downtown area as a high density mixed-use urban center of regional importance and primary hub for business, communications, office, government, high technology, retail, entertainment, and transportation in northern California. The proposed antenna will be within a shroud, mounted on top of the City light utility pole. The proposed antenna and related equipment are compatible with the typical utilities located on City light poles and will facilitate communication and technology in the downtown area. As a result, the proposal is an

appropriate location and would not significantly increase negative visual impacts to adjacent neighboring commercial, civic and residential properties.

Given increasing reliance upon cellular service for phone and internet, the proposal for a Monopole Telecommunications Facility will not adversely affect and detract from the characteristics of the neighborhood given the surrounding civic and government uses. The proposal is consistent and supports the intent to make the downtown a center for regional importance, a hub for businesses, communications and technology. Staff therefore finds the proposal, as conditioned, to conform to the General Plan.

Policy D4.1: Development activities should be supported through infrastructure improvements in the downtown.

Policy D4.2: A positive business climate which encourages attraction of new businesses, and retention and expansion of existing businesses in downtown Oakland should be fostered, promoting Oakland's locational advantages and other amenities.

Policy D9.2: Downtown residents should have access to goods and services to meet their daily and long-term needs with the downtown area.

Civic and Institutional Uses, Objective N2: Encourage adequate civic, institutional, and educational facilities located within Oakland, appropriately designed and sited to serve the community.

Objective N12: Provide adequate infrastructure to meet the needs of Oakland's growing community.

CONDITIONAL USE PERMIT CRITERIA FOR MONOPOLE FACILITIES (OMC SEC. 17.128.070(C))

1. The project must meet the special design review criteria listed in subsection B of this section.

The proposal conforms to the Design Review findings below.

2. Monopoles should not be located any closer than one thousand five hundred (1,500) feet from existing monopoles unless technologically required or visually preferable.

Use of this existing pole precludes the placement of a new pole with the facility viewable from the civic and commercial buildings, and is therefore, "visually preferable."

3. The proposed project must not disrupt the overall community character.

Attachment to an existing City light pole with the smallest possible components, painted and texturized, to match the pole will be the least intrusive design. The proposal, when viewed from the park will "blend in" with the existing tall evergreen trees across the street. The project will enhance existing service for businesses, civic and open space users in the area.

4. If a major conditional use permit is required, the Planning Director or the Planning Commission may request independent expert review regarding site location, collocation and facility configuration. Any party may request that the Planning Commission consider making such request for independent expert review.

a. If there is any objection to the appointment of an independent expert engineer, the applicant must notify the Planning Director within ten (10) days of the Commission request. The Commission will hear arguments regarding the need for the independent expert and the applicant's objection to having one appointed. The Commission will rule as to whether an independent expert should be appointed.

b. Should the Commission appoint an independent expert, the Commission will direct the Planning Director to pick an expert from a panel of licensed engineers, a list of which will be compiled, updated and maintained by the Planning Department.

- c. No expert on the panel will be allowed to review any materials or investigate any application without first signing an agreement under penalty of perjury that the expert will keep confidential any and all information learned during the investigation of the application. No personnel currently employed by a telecommunication company are eligible for inclusion on the list.
- d. An applicant may elect to keep confidential any proprietary information during the expert's investigation. However, if an applicant does so elect to keep confidential various items of proprietary information, that applicant may not introduce the confidential proprietary information for the first time before the Commission in support of the application.
- e. The Commission shall require that the independent expert prepare the report in a timely fashion so that it will be available to the public prior to any public hearing on the application.
- f. Should the Commission appoint an independent expert, the expert's fees will be paid by the applicant through the application fee, imposed by the City.

A Major Conditional Use Permit is required, and the Planning Director or Planning Commission may, therefore, require independent expert review in addition to that which is attached to this report.

REGULAR DESIGN REVIEW CRITERIA FOR NON-RESIDENTIAL FACILITIES (OMC SEC. 17.136.050(B))

- 1. That the proposed design will create a building or set of buildings that are well related to the surrounding area in their setting, scale, bulk, height, materials, and textures:**

Attachment to an existing City light pole with the smallest possible components, painted and texturized, to match the pole will be the least intrusive design. The proposal, when viewed from the park will "blend in" with the existing tall evergreen trees across the street. The project will enhance existing service for businesses, civic and open space users in the area. Therefore, the proposal will not have a significant view impact to the adjacent neighboring properties in this area.

- 2. That the proposed design will protect, preserve, or enhance desirable neighborhood characteristics;**

Attachment to an existing City light pole with the smallest possible components, painted and texturized, to match the pole will be the least intrusive design. The proposed telecommunication facility will not be located on an historic or decorative structure. The project will enhance existing service for businesses, civic and open space users in the area. Therefore, the proposal will not have a significant view impact to the adjacent neighboring properties in this area. The proposal is consistent and supports the intent to make to the downtown a center for regional importance, a hub for businesses, communications and technology.

- 3. The project will provide a necessary function without negatively impacting surrounding open space and hillside residential properties.**

The proposal will enhance essential services in the urbanized downtown. The proposal will be adjacent to Lake Merritt Park but will not impact use of the park. The proposal, when viewed from the park will "blend in" with the existing tall evergreen trees across the street. Residential uses are located more than 100' away and the area is surrounded by commercial and civic uses.

- 4. That the proposed design will be sensitive to the topography and landscape.**

The proposal will not be ground mounted.

- 5. That, if situated on a hill, the design and massing of the proposed building relates to the grade of the hill.**

This finding is inapplicable because the site is level.

6. That the proposed design conforms in all significant respects with the Oakland General Plan and with any applicable design review guidelines or criteria, district plan, or development control map which have been adopted by the Planning Commission or City Council.

See above E findings.

DESIGN REVIEW CRITERIA FOR MONOPOLE TELECOMMUNICATIONS FACILITIES (OMC SEC. 17.128.070(B))

1. Collocation is to be encouraged when it will decrease visual impact and collocation is to be discouraged when it will increase negative visual impact.

The project does not involve collocation as it involves the establishment of a new telecommunications facility; however, the project should not preclude any future proposals for location at the site.

2. Monopoles should not be sited to create visual clutter or negatively affect specific views.

The Monopole Facility is sited on existing infrastructure where it will not create clutter or negatively affect specific views. The proposal, when viewed from the park will "blend in" with the existing tall evergreen trees across the street. The view of the City street light from the adjacent commercial and civic buildings will be minimal.

3. Monopoles shall be screened from the public view wherever possible.

The Monopole Facility will be camouflaged and texturized to match the appearance of the existing light pole that will host it.

4. The equipment shelter, or cabinet must be concealed from public view or made compatible with the architecture of the surrounding structures or placed underground. The shelter or cabinet must be regularly maintained.

Recommended conditions of approval require painting and texturing the antenna and equipment to match the appearance of the metal pole. There is no equipment shelter or cabinet proposed; however minimal equipment would be closely mounted on the side of the metal pole.

5. Site location and development shall preserve the preexisting character of the surrounding buildings and land uses and the zone district as much as possible. Wireless communication towers shall be integrated through location and design to blend in with the existing characteristics of the site to the extent practical. Existing on-site vegetation shall be preserved or improved, and disturbance of the existing topography shall be minimized, unless such disturbance would result in less visual impact of the site to the surrounding area.

The proposed Monopole Facility will be placed on an existing non-decorative City light pole. This enables the preservation of character in the area. The facility will not pose a negative visual impact as the proposal will be camouflaged to match the pole, and the pole will "blend in" with the existing tall evergreen trees when seen from the park. There is no adjacent vegetation or topography that will be disturbed by the project.

6. That all reasonable means of reducing public access to the antennas and equipment has been made, including, but not limited to, placement in or on buildings or structures, fencing, anti-climbing measures and anti-tampering devices.

The minimal clearance to the facility will measure approximately 10' in height.

Attachment B: Conditions of Approval

1. Approved Use

The project shall be constructed and operated in accordance with the authorized use as described in the approved application materials, staff report and the approved plans dated **February 1st, 2018** and submitted **September 25, 2018**, as amended by the following conditions of approval and mitigation measures, if applicable (“Conditions of Approval” or “Conditions”).

2. Effective Date, Expiration, Extensions and Extinguishment

This Approval shall become effective immediately, unless the Approval is appealable, in which case the Approval shall become effective in ten calendar days unless an appeal is filed. Unless a different termination date is prescribed, this Approval shall expire two calendar years from the Approval date, or from the date of the final decision in the event of an appeal, unless within such period all necessary permits for construction or alteration have been issued, or the authorized activities have commenced in the case of a permit not involving construction or alteration. Upon written request and payment of appropriate fees submitted no later than the expiration date of this Approval, the Director of City Planning or designee may grant a one-year extension of this date, with additional extensions subject to approval by the approving body. Expiration of any necessary building permit or other construction-related permit for this project may invalidate this Approval if said Approval has also expired. If litigation is filed challenging this Approval, or its implementation, then the time period stated above for obtaining necessary permits for construction or alteration and/or commencement of authorized activities is automatically extended for the duration of the litigation.

3. Compliance with Other Requirements

The project applicant shall comply with all other applicable federal, state, regional, and local laws/codes, requirements, regulations, and guidelines, including but not limited to those imposed by the City’s Bureau of Building, Fire Marshal, and Public Works Department. Compliance with other applicable requirements may require changes to the approved use and/or plans. These changes shall be processed in accordance with the procedures contained in Condition #4.

4. Minor and Major Changes

- a. Minor changes to the approved project, plans, Conditions, facilities, or use may be approved administratively by the Director of City Planning.
- b. Major changes to the approved project, plans, Conditions, facilities, or use shall be reviewed by the Director of City Planning to determine whether such changes require submittal and approval of a revision to the Approval by the original approving body or a new independent permit/approval. Major revisions shall be reviewed in accordance with the procedures required for the original permit/approval. A new independent permit/approval shall be reviewed in accordance with the procedures required for the new permit/approval.

5. Compliance with Conditions of Approval

- a. The project applicant and property owner, including successors, (collectively referred to hereafter as the “project applicant” or “applicant”) shall be responsible for compliance with all the Conditions of Approval and any recommendations contained in any submitted and approved technical report at his/her sole cost and expense, subject to review and approval by the City of Oakland.
- b. The City of Oakland reserves the right at any time during construction to require certification by a licensed professional at the project applicant’s expense that the as-built project conforms to all applicable requirements, including but not limited to, approved maximum heights and minimum setbacks. Failure to construct the project in accordance with the Approval may result in remedial reconstruction, permit revocation, permit modification, stop work, permit suspension, or other corrective action.

- c. Violation of any term, Condition, or project description relating to the Approval is unlawful, prohibited, and a violation of the Oakland Municipal Code. The City of Oakland reserves the right to initiate civil and/or criminal enforcement and/or abatement proceedings, or after notice and public hearing, to revoke the Approval or alter these Conditions if it is found that there is violation of any of the Conditions or the provisions of the Planning Code or Municipal Code, or the project operates as or causes a public nuisance. This provision is not intended to, nor does it, limit in any manner whatsoever the ability of the City to take appropriate enforcement actions. The project applicant shall be responsible for paying fees in accordance with the City's Master Fee Schedule for inspections conducted by the City or a City-designated third-party to investigate alleged violations of the Approval or Conditions.

6. Signed Copy of the Approval/Conditions

A copy of the Approval letter and Conditions shall be signed by the project applicant, attached to each set of permit plans submitted to the appropriate City agency for the project, and made available for review at the project job site at all times.

7. Blight/Nuisances

The project site shall be kept in a blight/nuisance-free condition. Any existing blight or nuisance shall be abated within 60 days of approval, unless an earlier date is specified elsewhere.

8. Indemnification

- a. To the maximum extent permitted by law, the project applicant shall defend (with counsel acceptable to the City), indemnify, and hold harmless the City of Oakland, the Oakland City Council, the Oakland Redevelopment Successor Agency, the Oakland City Planning Commission, and their respective agents, officers, employees, and volunteers (hereafter collectively called "City") from any liability, damages, claim, judgment, loss (direct or indirect), action, causes of action, or proceeding (including legal costs, attorneys' fees, expert witness or consultant fees, City Attorney or staff time, expenses or costs) (collectively called "Action") against the City to attack, set aside, void or annul this Approval or implementation of this Approval. The City may elect, in its sole discretion, to participate in the defense of said Action and the project applicant shall reimburse the City for its reasonable legal costs and attorneys' fees.
- b. Within ten (10) calendar days of the filing of any Action as specified in subsection (a) above, the project applicant shall execute a Joint Defense Letter of Agreement with the City, acceptable to the Office of the City Attorney, which memorializes the above obligations. These obligations and the Joint Defense Letter of Agreement shall survive termination, extinguishment, or invalidation of the Approval. Failure to timely execute the Letter of Agreement does not relieve the project applicant of any of the obligations contained in this Condition or other requirements or Conditions of Approval that may be imposed by the City.

9. Severability

The Approval would not have been granted but for the applicability and validity of each and every one of the specified Conditions, and if one or more of such Conditions is found to be invalid by a court of competent jurisdiction this Approval would not have been granted without requiring other valid Conditions consistent with achieving the same purpose and intent of such Approval.

10. Job Site Plans

Ongoing throughout demolition, grading, and/or construction

At least one (1) copy of the stamped approved plans, along with the Approval Letter and Conditions of Approval, shall be available for review at the job site at all times.

11. Special Inspector/Inspections, Independent Technical Review, Project Coordination and Monitoring

The project applicant may be required to cover the full costs of independent third-party technical review and City monitoring and inspection, including without limitation, special inspector(s)/inspection(s) during times of extensive or specialized plan-check review or construction, and inspections of potential violations of the Conditions of Approval. The project applicant shall establish a deposit with the Bureau of Building, if directed by the Building Official, Director of City Planning, or designee, prior to the issuance of a construction-related permit and on an ongoing as-needed basis.

12. Public Improvements

The project applicant shall obtain all necessary permits/approvals, such as encroachment permits, obstruction permits, curb/gutter/sidewalk permits, and public improvement (“p-job”) permits from the City for work in the public right-of-way, including but not limited to, streets, curbs, gutters, sidewalks, utilities, and fire hydrants. Prior to any work in the public right-of-way, the applicant shall submit plans for review and approval by the Bureau of Planning, the Bureau of Building, and other City departments as required. Public improvements shall be designed and installed to the satisfaction of the City.

13. Construction Days/Hours

Requirement: The project applicant shall comply with the following restrictions concerning construction days and hours:

- a. Construction activities are limited to between 7:00 a.m. and 7:00 p.m. Monday through Friday, except that pier drilling and/or other extreme noise generating activities greater than 90 dBA shall be limited to between 8:00 a.m. and 4:00 p.m.
- b. Construction activities are limited to between 9:00 a.m. and 5:00 p.m. on Saturday. In residential zones and within 300 feet of a residential zone, construction activities are allowed from 9:00 a.m. to 5:00 p.m. only within the interior of the building with the doors and windows closed. No pier drilling or other extreme noise generating activities greater than 90 dBA are allowed on Saturday.
- c. No construction is allowed on Sunday or federal holidays.

Construction activities include, but are not limited to, truck idling, moving equipment (including trucks, elevators, etc.) or materials, deliveries, and construction meetings held on-site in a non-enclosed area.

Any construction activity proposed outside of the above days and hours for special activities (such as concrete pouring which may require more continuous amounts of time) shall be evaluated on a case-by-case basis by the City, with criteria including the urgency/emergency nature of the work, the proximity of residential or other sensitive uses, and a consideration of nearby residents’/occupants’ preferences. The project applicant shall notify property owners and occupants located within 300 feet at least 14 calendar days prior to construction activity proposed outside of the above days/hours. When submitting a request to the City to allow construction activity outside of the above days/hours, the project applicant shall submit information concerning the type and duration of proposed construction activity and the draft public notice for City review and approval prior to distribution of the public notice.

When Required: During construction

Initial Approval: N/A

Monitoring/Inspection: Bureau of Building

PROJECT-SPECIFIC CONDITIONS

14. Emissions Report

Requirement: A RF emissions report shall be submitted to the Planning Bureau indicating that the site is actually operating within the acceptable thresholds as established by the Federal government or any such agency who may be subsequently authorized to establish such standards.

Requirement: Prior to a final inspection
When Required: Prior to final building permit inspection sign-off
Initial Approval: N/A
Monitoring/Inspection: N/A

15. Camouflage

Requirement: The antenna and equipment shall be painted, texturized, and maintained the same color and finish of the City light pole.
When Required: Prior to a final inspection
Initial Approval: N/A
Monitoring/Inspection: Bureau of Building

16. Operational

Requirement: Noise levels from the activity, property, or any mechanical equipment on site shall comply with the performance standards of Section 17.120 of the Oakland Planning Code and Section 8.18 of the Oakland Municipal Code. If noise levels exceed these standards, the activity causing the noise shall be abated until appropriate noise reduction measures have been installed and compliance verified by the Planning and Zoning Division and Building Services.
When Required: Ongoing
Initial Approval: N/A
Monitoring/Inspection: Bureau of Building

17. Graffiti Control

Requirement:

- a. During construction and operation of the project, the project applicant shall incorporate best management practices reasonably related to the control of graffiti and/or the mitigation of the impacts of graffiti. Such best management practices may include, without limitation:
- a. The project applicant shall remove graffiti by appropriate means within seventy-two (72) hours. Appropriate means include the following:
 - i. Removal through scrubbing, washing, sanding, and/or scraping (or similar method) without damaging the surface and without discharging wash water or cleaning detergents into the City storm drain system.
 - ii. For galvanized poles, covering with new paint to match the color of the surrounding surface.
 - iii. Replace pole numbers.

When Required: Ongoing
Initial Approval: N/A
Monitoring/Inspection: Bureau of Building

Applicant Statement

I have read and accept responsibility for the Conditions of Approval. I agree to abide by and conform to the Conditions of Approval, as well as to all provisions of the Oakland Planning Code and Oakland Municipal Code pertaining to the project.

Name of Project Applicant

Signature of Project Applicant

Date

PROJECT TEAM

APPLICANT:
AT&T
5001 Executive Parkway
San Ramon, Co 94583

ARCHITECT/ENGINEER:
Rodney Barnes
Meridian Management LLC
785 Oak Grove Road E2
Suite 251
Concord, CA 94518
T 707.592.5924
rodney@meridian.management

ZONING CONTACT
Justin Giamitta
Vinculums Services
575 Lennon Lane
Suite 125
Walnut Creek, CA 94598
T 707.225.2865
jgiamitta@vinculums.com

LEASING CONTACT:
Justin Giamitta
Vinculums Services
575 Lennon Lane
Suite 125
Walnut Creek, CA 94598
T 707.225.2865
jgiamitta@vinculums.com

CONSTRUCTION MANAGER:
Vinculums Services
575 Lennon Lane
Suite 125
Walnut Creek, CA 94598

CODE COMPLIANCE

ALL WORK AND MATERIALS SHALL BE PERFORMED AND INSTALLED IN ACCORDANCE WITH THE CURRENT EDITIONS OF THE FOLLOWING CODES AS ADOPTED BY THE LOCAL GOVERNING AUTHORITIES. NOTHING IN THESE PLANS IS TO BE CONSTRUCTED TO PERMIT WORK NOT CONFORMING TO THESE CODES:

- CALIFORNIA CODES
- 2016 CALIFORNIA BUILDING CODE
- 2016 CALIFORNIA MECHANICAL CODE
- 2016 CALIFORNIA PLUMBING CODE
- 2016 CALIFORNIA ELECTRIC CODE
- 2016 GREEN BUILDING CODE
- 2016 EDITION OF TITLE 24 ENERGY STANDARDS
- ANY LOCAL BUILDING CODE AMENDMENTS TO THE ABOVE
- CITY / COUNTY ORDINANCES
- CITY OF OAKLAND PUBLIC WORKS DEPARTMENT
- GENERAL ORDER 95 (JUNE 2009 EDITION)

SITE IMAGE



5001 EXECUTIVE PARKWAY, SAN RAMON, CA 94583

CRAN-RSFR-SFOK6-015

PACE ID:
ROW AT 66 LAKE MERRITT BLVD, OAKLAND, CA 94612
COUNTY: ALAMEDA
SITE TYPE: METAL STREET LIGHT POLE
FA:14307065 HUB:19 USID:192863



DRIVING DIRECTIONS

FROM AT&T WIRELESS OFFICE AT 5001 EXECUTIVE PARKWAY, SAN RAMON, CA

1. Head north-east on Bishop Dr towards Sunset Dr
2. Turn right onto Sunset Dr
3. Use the right 2 lanes to turn right onto Ballinger Canyon Rd
4. Use the right 2 lanes to merge onto I-680 N via the slip road to Sacramento
5. Merge onto I-680 N
6. Use the right 2 lanes to take exit 46A for State Route 24 towards Oakland/Lafayette
7. Continue onto CA-24 W
8. Keep left at the fork to stay on CA-24 W
9. Use the right 2 lanes to take exit 2B for Interstate 580 E towards Hayward
10. Merge onto I-580 E
11. Take the exit towards Grand Ave/Lakeshore Ave
12. Merge onto MacArthur Blvd
13. Turn right onto Lakeshore Ave
14. Continue onto 1st Ave
15. Continue onto Lake Merritt Blvd

INDEX

| | |
|-----|---|
| T.1 | TITLE SHEET |
| A.1 | OVERALL SITE PLAN |
| A.2 | POLE PLAN, EQUIPMENT ENLARGEMENTS |
| A.3 | ELEVATIONS |
| A.4 | ELEVATIONS |
| A.5 | EQUIPMENT DETAILS |
| A.6 | EQUIPMENT DETAILS |
| E.1 | SINGLE LINE DIAGRAM |
| E.2 | ELECTRICAL PLAN, POLE GROUNDING, ELECTRICAL DETAILS |

PROJECT DESCRIPTION

THIS IS AN UNMANNED TELECOMMUNICATIONS FACILITY FOR THE AT&T WIRELESS NETWORK CONSISTING OF THE INSTALLATION AND OPERATION OF AN ANTENNA AND ASSOCIATED EQUIPMENT ON AN EXISTING METAL LIGHT POLE IN THE PUBLIC RIGHT-OF-WAY.

SCOPE OF WORK & SITE COMPLETION CHECKLIST:

1. ANTENNA & ASSOCIATED EQUIPMENT BOXES: INSTALL A NEW TELECOMMUNICATION ANTENNA AND 2 EQUIPMENT BOXES ON AN EXISTING METAL LIGHT POLE. INSTALL A SMART METER INSIDE THE ANTENNA SHROUD ON TOP OF EXISTING LIGHT POLE.
2. DURABLE PAINT: ANTENNAS, MOUNTING BRACKETS, CABLING, AND RADIO RELAY UNITS TO BE PAINTED TO MATCH THE EXISTING POLE USING A DURABLE PAINT [E.G. SHERWIN WILLIAMS, FRAZEE, KELLY MOORE, OR EQUIVALENT]
3. CABLING: CABLING TO BE INSTALLED IN A TIDY MANNER WITHOUT EXCESS CABLE LOOPS
4. LOGO REMOVAL: ALL EQUIPMENT LOGOS, OTHER THAN THOSE REQUIRED BY REGULATION [E.G. NODE IDENTIFICATION] SHALL BE PAINTED OVER OR REMOVED. RAISED/DEPRESSED TEXT ON RRUS OR OTHER EQUIPMENT, IF PRESENT, TO BE SANDED OFF OR SIMILARLY REMOVED AND/OR FILLED
5. SIGNAGE: SHALL BE PLACED PER EME REPORT AND RFSAP
6. UTILITY LINES: PROPOSED UTILITY LINES BETWEEN EXISTING POINT OF CONNECTION TO BE IN CONDUIT INSIDE POLE

GENERAL NOTES

1. PLANS ARE INTENDED TO BE DIAGRAMMATIC OUTLINE ONLY, UNLESS NOTED OTHERWISE. THE WORK SHALL INCLUDE FURNISHING MATERIALS, EQUIPMENT, APPURTENANCES AND LABOR NECESSARY TO COMPLETE ALL INSTALLATIONS AS INDICATED ON THE DRAWINGS.
2. THIS IS AN UNMANNED TELECOMMUNICATIONS FACILITY FOR THE AT&T WIRELESS NETWORK CONSISTING OF THE INSTALLATION AND OPERATION OF AN ANTENNA AND ASSOCIATED EQUIPMENT ON AN EXISTING METAL LIGHT POLE IN THE PUBLIC RIGHT-OF-WAY. THE FACILITY IS UNMANNED AND NOT FOR HUMAN HABITATION.
3. A TECHNICIAN WILL VISIT THE SITE AS REQUIRED FOR ROUTINE MAINTENANCE. THE PROJECT WILL NOT RESULT IN ANY SIGNIFICANT DISTURBANCE OR EFFECT DRAINAGE. NO SANITARY SEWER SERVICE, POTABLE WATER, OR TRASH DISPOSAL IS REQUIRED AND NO COMMERCIAL SIGNAGE IS PROPOSED.
4. CHANGES FROM THE APPROVED PLANS DURING THE COURSE OF CONSTRUCTION SHALL CAUSE CONSTRUCTION TO BE SUSPENDED UNTIL SUCH TIME AS THE PLANS CAN BE AMENDED BY THE DESIGNER AND SUBMITTED TO THE CITY FOR REVIEW AND APPROVAL
5. THE CONTRACTOR SHALL INSTALL ALL EQUIPMENT AND MATERIALS IN ACCORDANCE WITH MANUFACTURER'S RECOMMENDATIONS UNLESS SPECIFICALLY INDICATED OTHERWISE, OR WHERE LOCAL CODES OR REGULATIONS TAKE PRECEDENCE.
6. CONTRACTOR SHALL VERIFY ALL EXISTING UTILITIES, BOTH HORIZONTAL AND VERTICALLY, PRIOR TO THE START OF CONSTRUCTION. ANY DISCREPANCIES OR DOUBTS AS TO THE INTERPRETATION OF PLANS SHOULD BE IMMEDIATELY REPORTED TO THE ARCHITECT / ENGINEER FOR RESOLUTION AND INSTRUCTION. AND NO FURTHER WORK SHALL BE PERFORMED UNTIL THE DISCREPANCY IS CHECKED AND CORRECTED BY THE ARCHITECT / ENGINEER. FAILURE TO SECURE SUCH INSTRUCTION MEANS CONTRACTOR WILL HAVE WORKED AT HIS/HER OWN RISK AND EXPENSE.
7. THE CONTRACTOR SHALL OBTAIN, IN WRITING, AUTHORIZATION TO PROCEED BEFORE STARTING WORK ON ANY ITEM NOT CLEARLY DEFINED OR IDENTIFIED BY THE CONTRACT DOCUMENTS.

SITE INFORMATION

OWNER: CITY OF OAKLAND
APPLICANT: AT&T
5001 EXECUTIVE PARKWAY
SAN RAMON, CA 94583
LATITUDE: 37.8011400 (NAD 83)
LONGITUDE: -122.2626300 (NAD 83)
GROUND ELEVATION: 22' AMSL
ADJACENT APN#: (IFO) 10-764-3
ZONING JURISDICTION: CITY OF OAKLAND
CURRENT ZONING: PUBLIC ROW
PROPOSED USE: UNMANNED TELECOMMUNICATIONS FACILITY

DO NOT SCALE DRAWINGS

CONTRACTOR SHALL VERIFY ALL PLANS, EXISTING DIMENSIONS & FIELD CONDITIONS ON THE JOB SITE & SHALL IMMEDIATELY NOTIFY THE ENGINEER IN WRITING OF ANY DISCREPANCIES BEFORE PROCEEDING WITH THE WORK OR BE RESPONSIBLE FOR SAME

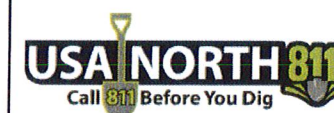

AT&T Wireless
5001 Executive Parkway
San Ramon, CA 94583

Client:



Project Architect:



575 LENNON LANE
SUITE 125
WALNUT CREEK, CA 94598
T 925.482.8500

Site Agent:

100% Construction Drawings

Drawing Phase:

CRAN-RSFR-SFOK6-015
PACE ID:
ROW AT 66 LAKE MERRITT BLVD
OAKLAND, CA 94612
COUNTY: ALAMEDA

Site Name:



Professional Seal:

It is a violation of law for any person, unless they are acting under the direction of a licensed Professional Architect/Engineer, to alter this document.

| Rev. | Date | Description |
|------|----------|-----------------------|
| 01 | 09/14/17 | Zoning Dwg 90% |
| 02 | 10/06/17 | Zoning Dwg 95% |
| 03 | 03/20/19 | Construction Dwg 100% |

Project No.:

Date: 03/20/19 Job No.:

Scale: AS SHOWN CAD File:

Designed By: JG Checked: RB

TITLE SHEET

Sheet Title:

T.1

Sheet No.:

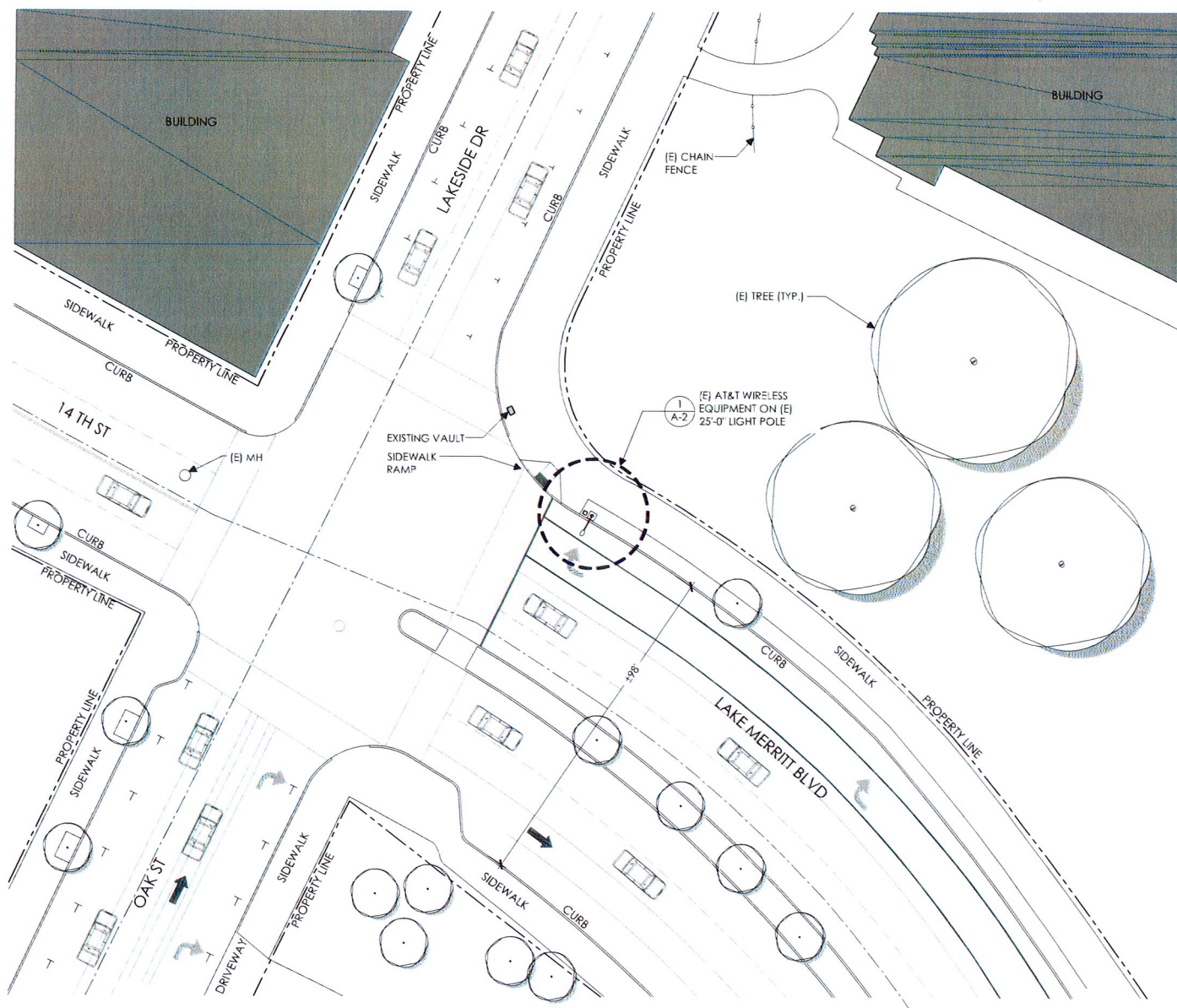

NOTE:
 THIS SITE PLAN WAS GENERATED WITHOUT THE USE OF A SURVEY. PROPERTY LINES, RIGHT-OF-WAYS, POWER & TELCO UTILITY POINT CONNECTIONS/ROUTES AND EASEMENTS SHOWN ON THESE PLANS ARE ESTIMATED. ALL ITEMS AND DIMENSIONS SHOULD BE VERIFIED IN THE FIELD.

UNDERGROUND UTILITIES NOTE:
 THE LOCATIONS AND EXISTENCE OF ANY UNDERGROUND PIPES, STRUCTURES, OR CONDUITS SHOWN ON THIS PLAN WERE OBTAINED BY A SEARCH OF AVAILABLE RECORDS. THERE MAY BE EXISTING UTILITIES OTHER THAN THOSE SHOWN ON THIS PLAN. THE CONTRACTOR IS REQUIRED TO TAKE PRECAUTIONARY MEASURES TO PROTECT THE UTILITY LINES SHOWN AND ANY OTHER LINES NOT SHOWN ON THIS PLAN.

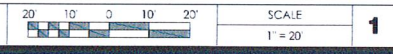

AT&T Wireless
 5001 Executive Parkway
 San Ramon, CA 94583

Client:



Project Architect:



Site Agent:

100% Construction Drawings

Drawing Phase:

CRAN-RSFR-SFOK6-015
 PACE ID:
 ROW AT 66 LAKE MERRITT BLVD
 OAKLAND, CA 94612
 COUNTY: ALAMEDA

Site Name:



Professional Seal:

It is a violation of law for any person, unless they are acting under the direction of a licensed Professional Architect/Engineer, to alter this document.

| Rev. | Date | Description |
|------|----------|------------------------|
| 01 | 09/14/17 | Zoning Dwg. 90% |
| 02 | 10/06/17 | Zoning Dwg. 95% |
| 03 | 03/20/19 | Construction Dwg. 100% |

Project No.:

Date: 03/20/19 Job No.:

Scale: AS SHOWN CAD File:

Designed By: JG Checked: RB

OVERALL SITE PLAN

Sheet Title:

A.1

Sheet No.:

© Meridian Management LLC, 2019

NOTES:

1. DURABLE PAINT: ANTENNAS, MOUNTING BRACKETS, CABLING, AND RADIO RELAY UNITS TO BE PAINTED TO MATCH THE EXISTING POLE USING A DURABLE PAINT (E.G. SHERWIN WILLIAMS, FRAZEE, KELLY MOORE, OR EQUIVALENT)
2. CABLING: CABLING TO BE INSTALLED IN A TIDY MANNER WITHOUT EXCESS CABLE LOOPS. ALL CABLING TO GROUND-MOUNTED BOXES AND ANTENNAS TO BE INSTALLED INSIDE POLE
3. LOGO REMOVAL: ALL EQUIPMENT LOGOS, OTHER THAN THOSE REQUIRED BY REGULATION (E.G. NODE IDENTIFICATION), SHALL BE PAINTED OVER OR REMOVED. RAISED/DEPRESSED TEXT ON RRUS OR OTHER EQUIPMENT, IF PRESENT, TO BE SANDED OFF OR SIMILARLY REMOVED AND/OR FILLED
4. SIGNAGE: TO BE PLACED PER EME / RFSAP REPORT

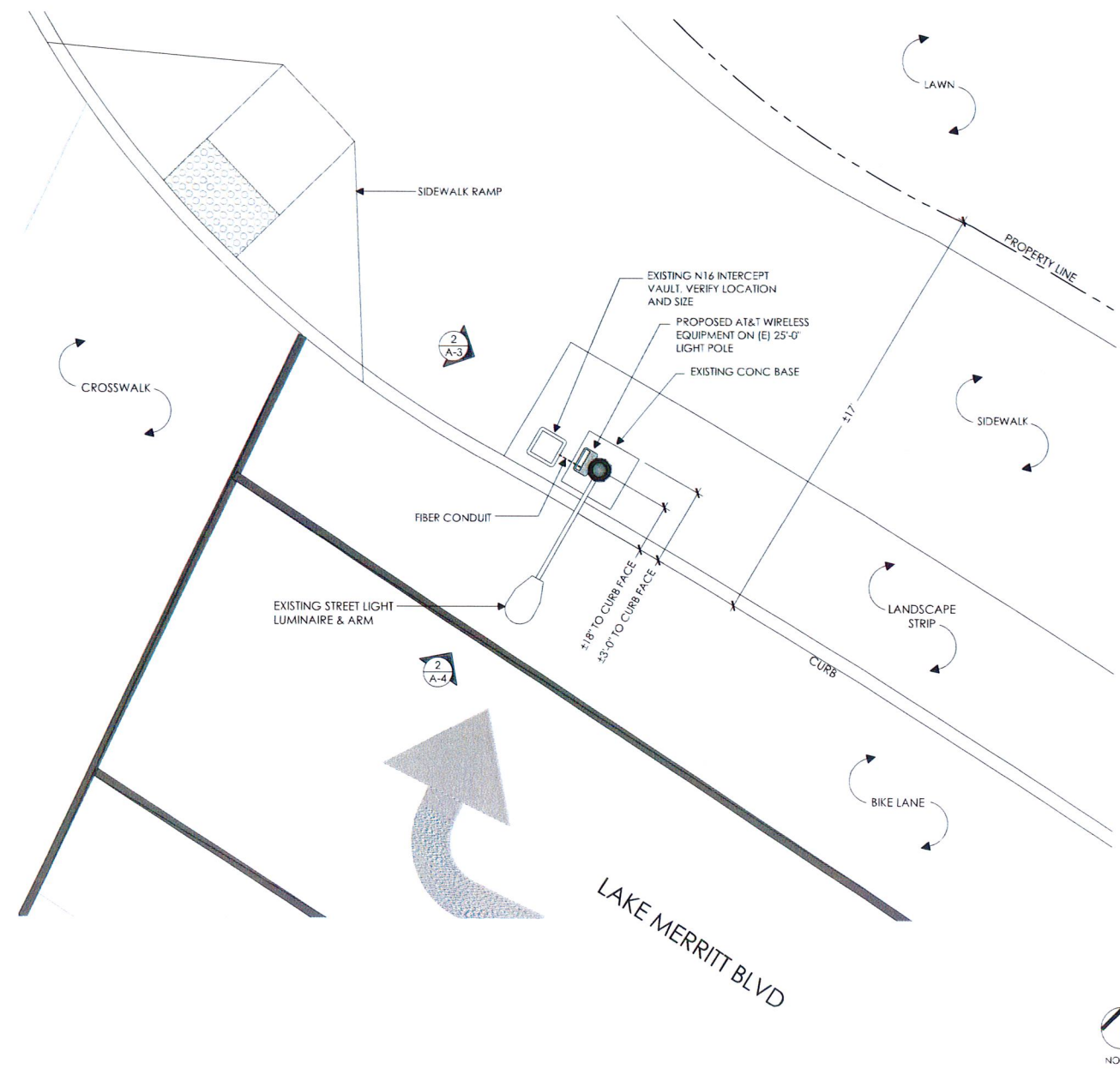

POLE PLAN ENLARGEMENT

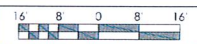

SCALE
3/8" = 1'-0"

1

EQUIPMENT ENLARGEMENT PLAN

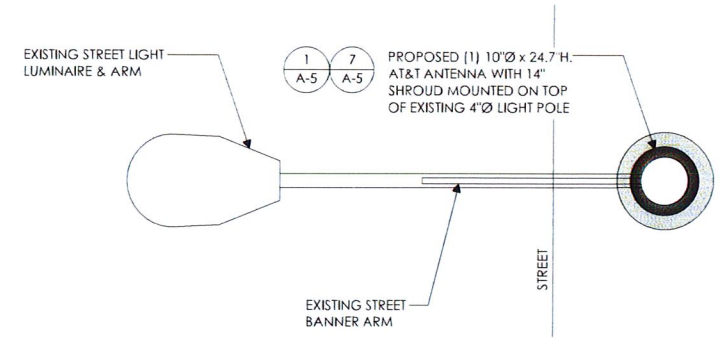

A. SECTION (AT&T ANTENNA)

ANTENNA ENLARGEMENT PLAN

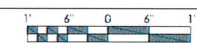

SCALE
1" = 1'-0"

2

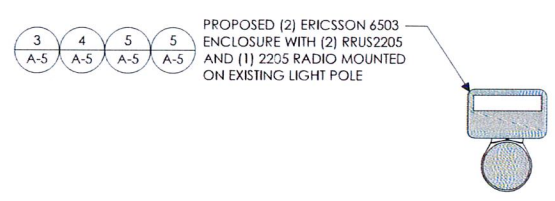

B. SECTION (RRUS)

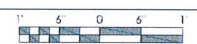

SCALE
1" = 1'-0"

3



AT&T Wireless
5001 Executive Parkway
San Ramon, CA 94583

Client:



Project Architect:



375 LENNON LANE
SUITE 125
WALNUT CREEK, CA 94598
T 925.482.8500

Site Agent:

100% Construction Drawings

(E) LIGHT POLE
Drawing Phase:

CRAN-RSFR-SFOK6-015
FACE ID:
ROW AT 66 LAKE MERRITT BLVD
OAKLAND, CA 94612
COUNTY: ALAMEDA

Site Name:



Professional Seal:

It is a violation of law for any person, unless they are acting under the direction of a licensed Professional Architect/Engineer, to alter this document.

| Rev. | Date | Description |
|------|----------|-----------------------|
| 01 | 09/14/17 | Zoning Dwg 90% |
| 02 | 10/06/17 | Zoning Dwg 95% |
| 03 | 03/20/19 | Construction Dwg 100% |

Project No.:

Date: 03/20/19 Job No.:

Scale: AS SHOWN CAD File:

Designed By: JG Checked: RB

POLE PLAN EQUIPMENT ENLARGEMENTS

Sheet Title:

A.2

Sheet No.:

© Meridian Management LLC, 2019

SCALE NOTE:
IF DIMENSIONS SHOWN ON PLAN DO NOT SCALE
CORRECTLY, CHECK FOR REDUCTION OR
ENLARGEMENT FROM ORIGINAL PLANS.

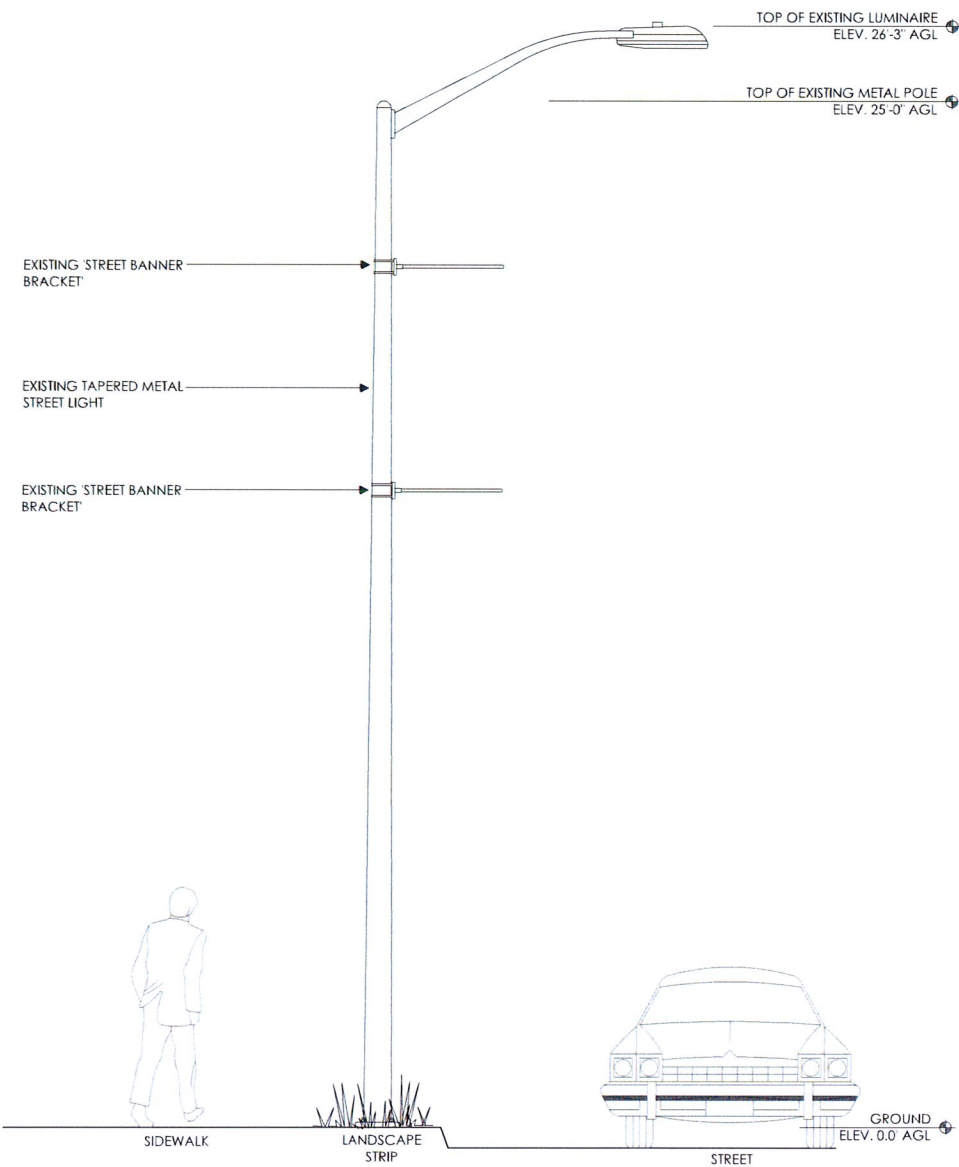

NORTHWEST ELEVATION - EXISTING

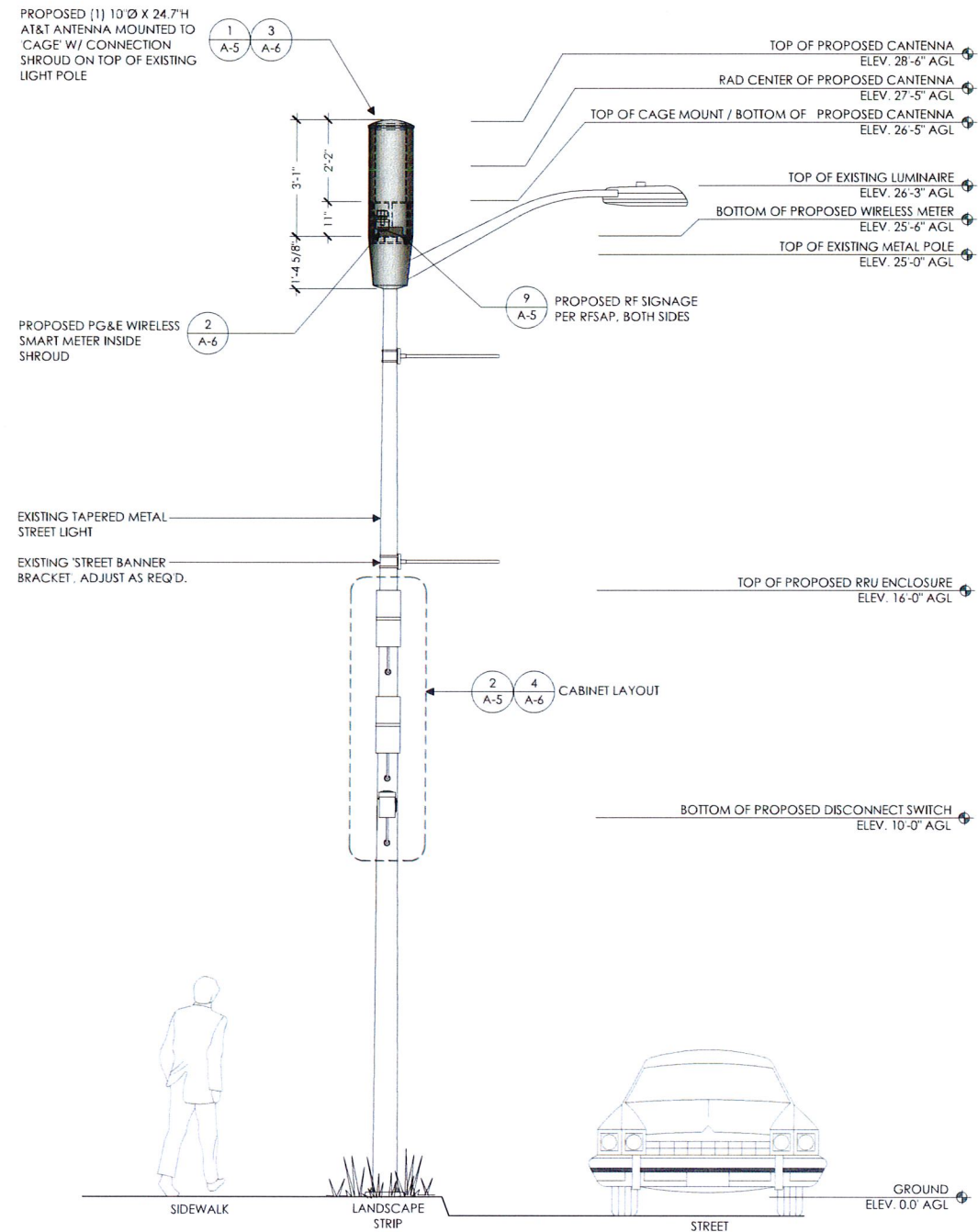
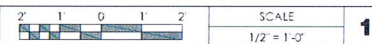

NORTHWEST ELEVATION - PROPOSED



AT&T Wireless
5001 Executive Parkway
San Ramon, CA 94583

Client:



Project Architect:



Site Agent:

100% Construction Drawings

Drawing Phase:

CRAN-RSFR-SFOK6-015
PACE ID:
ROW AT 66 LAKE MERRITT BLVD
OAKLAND, CA 94612
COUNTY: ALAMEDA

Site Name:



Professional Seal:

It is a violation of law for any person, unless they are acting under the direction of a licensed Professional Architect/Engineer, to alter this document.

| Rev. | Date | Description |
|------|----------|------------------------|
| 01 | 09/14/17 | Zoning Dwg. 90% |
| 02 | 10/06/17 | Zoning Dwg. 95% |
| 03 | 03/20/19 | Construction Dwg. 100% |

Project No.:

Date: 03/20/19 Job No.:

Scale: AS SHOWN CAD File:

Designed By: JG Checked: RB

ELEVATIONS

Sheet Title:

A.3

Sheet No.:

© Meridian Management LLC 2019

SCALE NOTE:
IF DIMENSIONS SHOWN ON PLAN DO NOT SCALE CORRECTLY, CHECK FOR REDUCTION OR ENLARGEMENT FROM ORIGINAL PLANS.

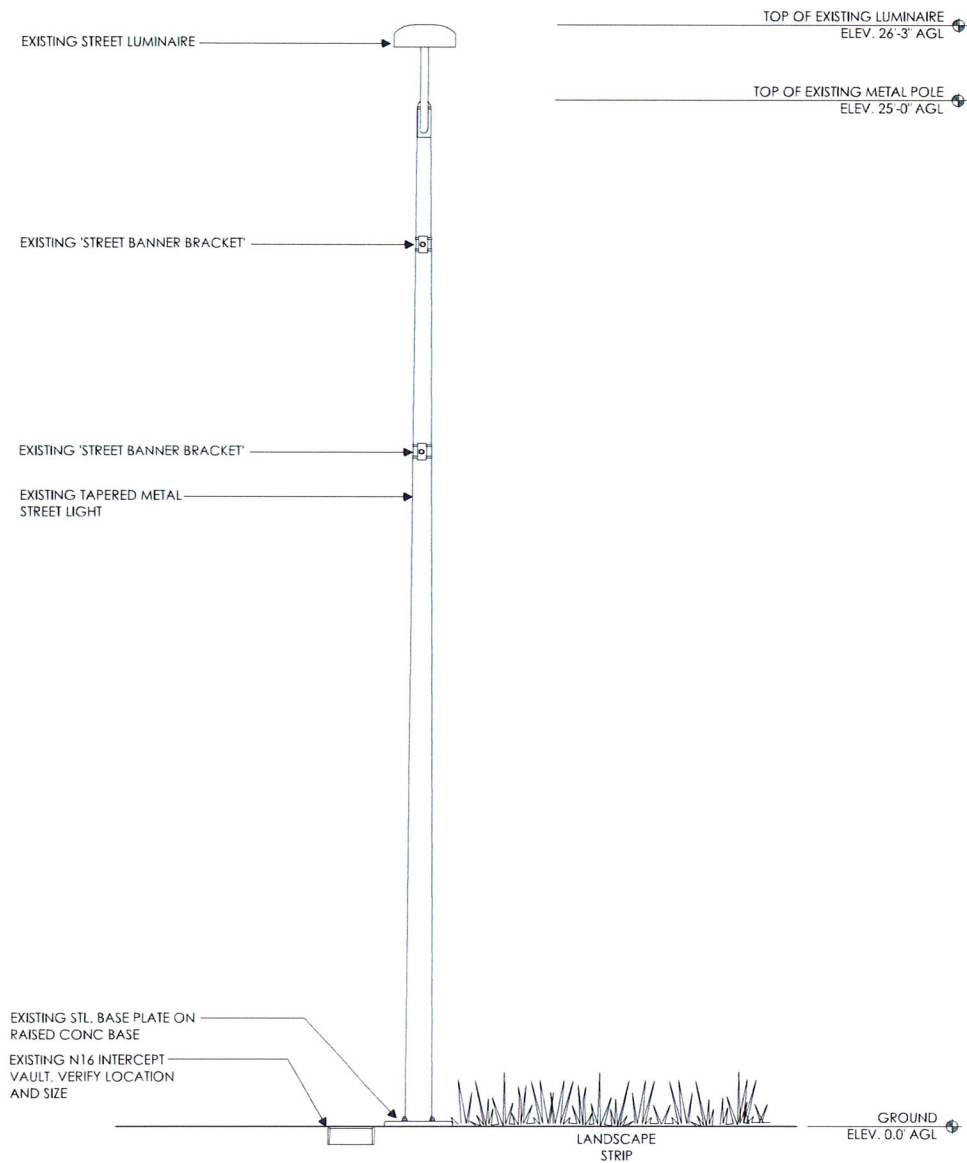

SOUTHWEST ELEVATION - EXISTING



SCALE
1/2" = 1'-0"

1

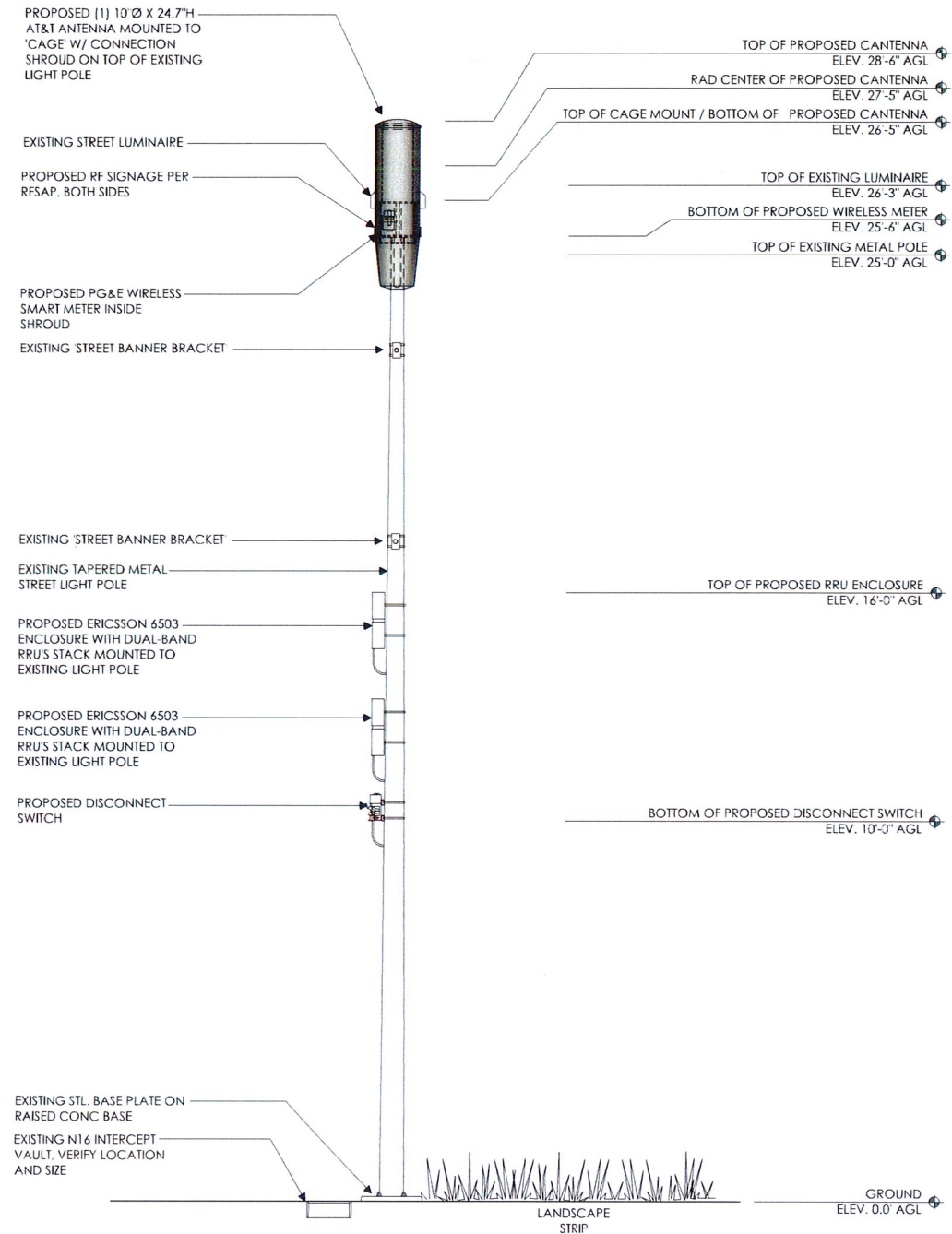

SOUTHWEST ELEVATION - PROPOSED

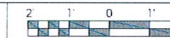

SCALE
1/2" = 1'-0"

2



AT&T Wireless
5001 Executive Parkway
San Ramon, CA 94583

Client:



Project Architect:



375 LENNON LANE
SUITE 125
WALNUT CREEK, CA 94598
T 925.482.8500

Site Agent:

100% Construction
Drawings

Drawing Phase:

CRAN-RSFR-SFOK6-015

PACE ID:
ROW AT 66 LAKE MERRITT BLVD
OAKLAND, CA 94612
COUNTY: ALAMEDA

Site Name:



Professional Seal:

It is a violation of law for any person, unless they are acting under the direction of a licensed Professional Architect/Engineer, to alter this document.

| Rev. | Date | Description |
|------|----------|-----------------------|
| 01 | 09/14/17 | Zoning Dwg 90% |
| 02 | 10/06/17 | Zoning Dwg 95% |
| 03 | 03/20/19 | Construction Dwg 100% |

Project No.:

Date: 03/20/19 Job No.:

Scale: AS SHOWN CAD File:

Designed By: JG Checked: RB

ELEVATIONS

Sheet Title:

A.4

Sheet No.:

© Meridian Management LLC, 2019

AT&T AT&T ANTENNA 'CAN-TENNA'

ANTENNA COLOR: LIGHT GRAY
 DIMENSIONS: 10.0"Ø x 24.7" TALL
 NET WEIGHT: 19.0 LBS

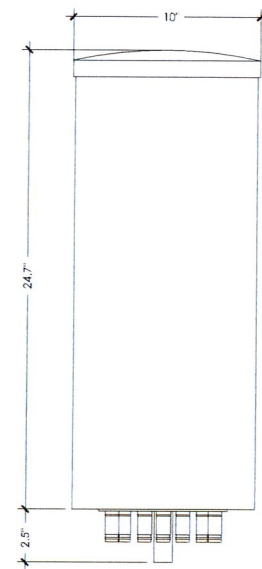

ERICSSON 6503

SINGLE BAND 2205: 2 TX / 2 RX (AWS OR PCS)
 DUAL BAND RRU (2 - 2205S): 4 TX / 4 RX (AWS OR PCS)
 MAXIMUM POWER CONSUMPTION: <100W PER 2205 RADIO- ±95W PER SINGLE-BAND 2205 RADIO ±190W PER DUAL-BAND 2205 RRU

MAX FUSE RATING: 32A
 WIRE SIZE: #10 CU OR #8 ALU

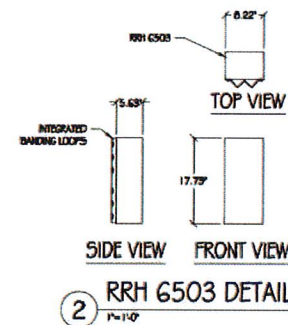
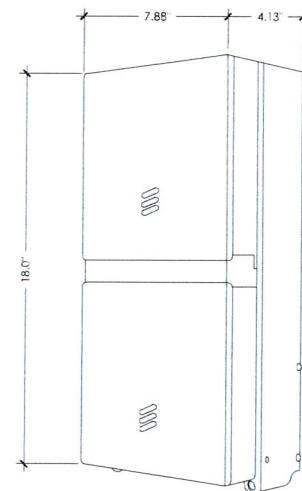

SQUARE D D22NRB DISCONNECT SWITCH

VOLTAGE: 240VACIP RATING: 14
 MATERIAL OF CONSTRUCTION: GALVANNEALED STEEL
 DUTY: GENERAL
 WIDTH: 7.7"
 METALLIC / NON-METALLIC: METALLIC
 NEMA ENCLOSURE TYPE: 3R
 HP: 15 HP @ 240VAC
 HEIGHT: 9.6"
 FUSIBLE / NONFUSIBLE: NONFUSIBLE
 STANDARDS: UL LISTED
 NUMBER OF POLES: 3
 DEPTH: 3.8 CONTACT FORM: 3PST
 ITEM: SINGLE THROW SAFETY SWITCH
 NUMBER OF WIRES: 3
 PHASE: 3
 AMPS AC: 60

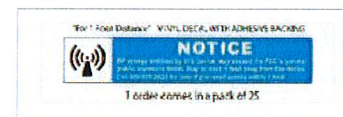

RF WARNING SIGNAGE

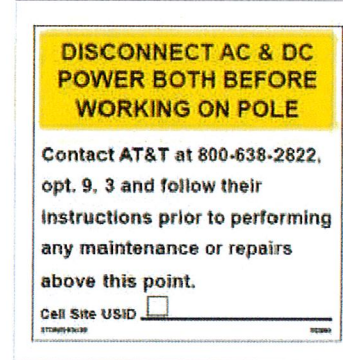

DISCONNECT SIGNAGE

ANTENNA

SCALE: NOT TO SCALE

1

RRU6503 ENCLOSURE

SCALE: NOT TO SCALE

3

RRU6503

4

DISCONNECT SWITCH (OR EQUAL)

8

SIGNAGE

9

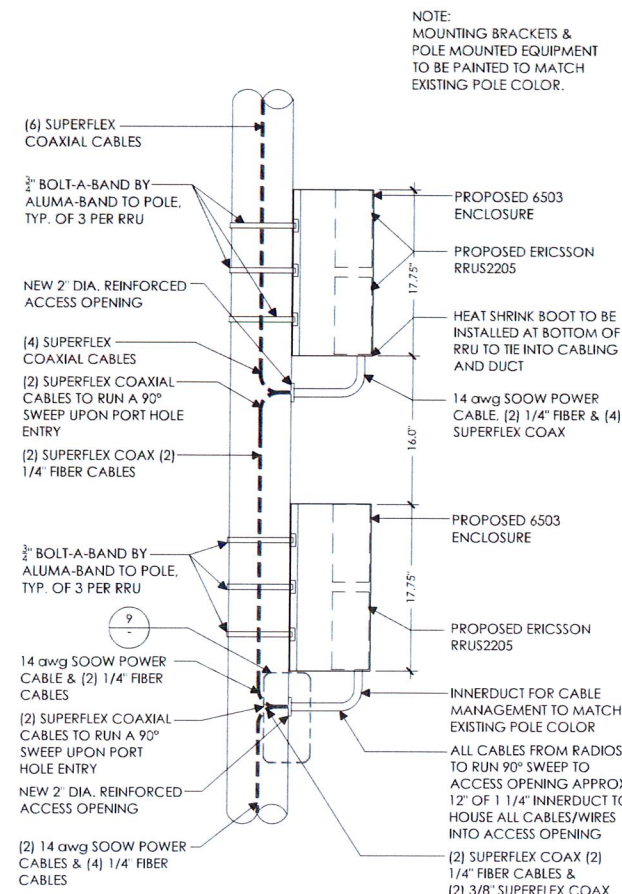

NOTE: MOUNTING BRACKETS & POLE MOUNTED EQUIPMENT TO BE PAINTED TO MATCH EXISTING POLE COLOR.

RRU2203

5

RRU2205

6

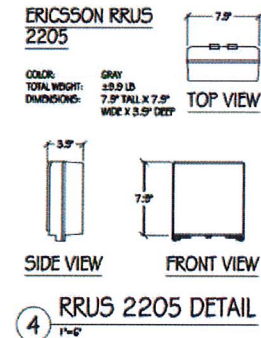
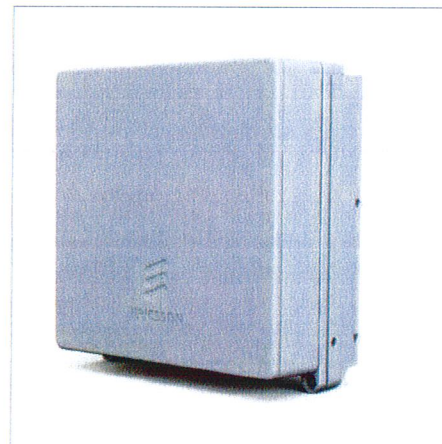

RRU2205 DETAIL

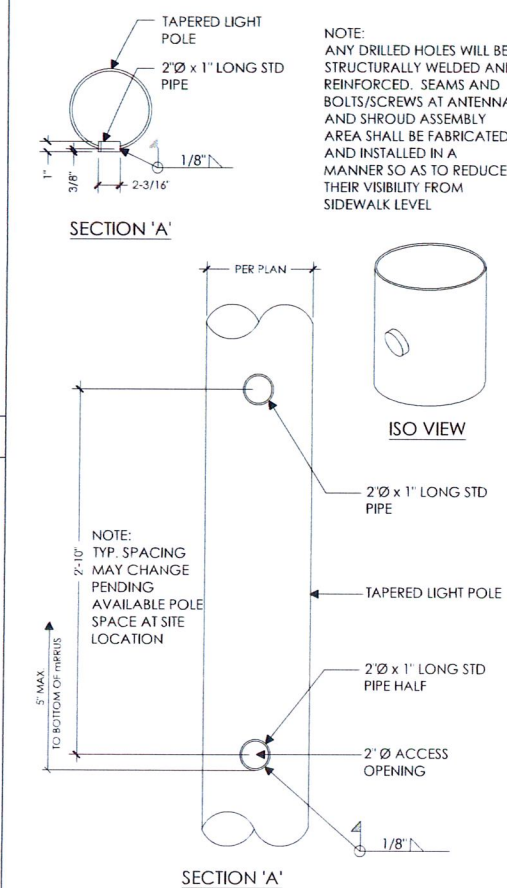

NOTE: ANY DRILLED HOLES WILL BE STRUCTURALLY WELDED AND REINFORCED. SEAMS AND BOLTS/SCREWS AT ANTENNA AND SHROUD ASSEMBLY AREA SHALL BE FABRICATED AND INSTALLED IN A MANNER SO AS TO REDUCE THEIR VISIBILITY FROM SIDEWALK LEVEL.

NOTE: TYP. SPACING MAY CHANGE PENDING AVAILABLE POLE SPACE AT SITE LOCATION

DUAL BAND RRU MOUNT

SCALE: NOT TO SCALE

2

NOT USED

7

RRU2205 VERTICAL ACCESS PORTS

SCALE: NOT TO SCALE

10



AT&T Wireless
 5001 Executive Parkway
 San Ramon, CA 94583

Client:



Project Architect:



375 LENNON LANE
 SUITE 125
 WALNUT CREEK, CA 94598
 T 925.482.8500

Site Agent:

100% Construction Drawings

Drawing Phase:

CRAN-RSFR-SFOK6-015

FACE ID:
 ROW AT 66 LAKE MERRITT BLVD
 OAKLAND, CA 94612
 COUNTY: ALAMEDA

Site Name:



Professional Seal:

It is a violation of law for any person, unless they are acting under the direction of a licensed Professional Architect/Engineer, to alter this document.

| Rev. | Date | Description |
|------|----------|-----------------------|
| 01 | 09/14/17 | Zoning Dwg 90% |
| 02 | 10/06/17 | Zoning Dwg 95% |
| 03 | 03/20/19 | Construction Dwg 100% |

Project No.:

Date: 03/20/19 Job No.:

Scale: AS SHOWN CAD File:

Designed By: JG Checked: RB

EQUIPMENT DETAILS

Sheet Title:

A.5

Sheet No.:

© Meridian Management LLC, 2019

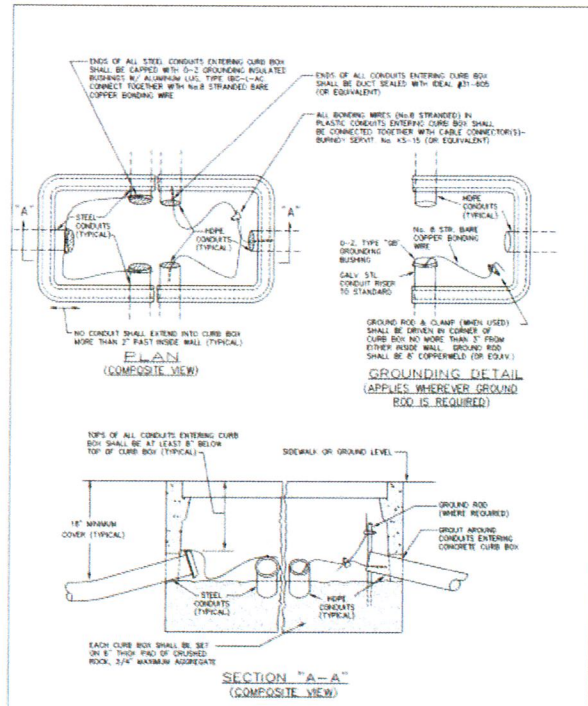

CITY OF OAKLAND ENGINEERING AND DESIGN SERVICES DEPARTMENT
 ARRANGEMENT OF CURB BOX & CONDUITS
 ELECTRICAL SERVICES MANAGER
 DATE: 03/20/19
 REV: 01/01/19
 E-7

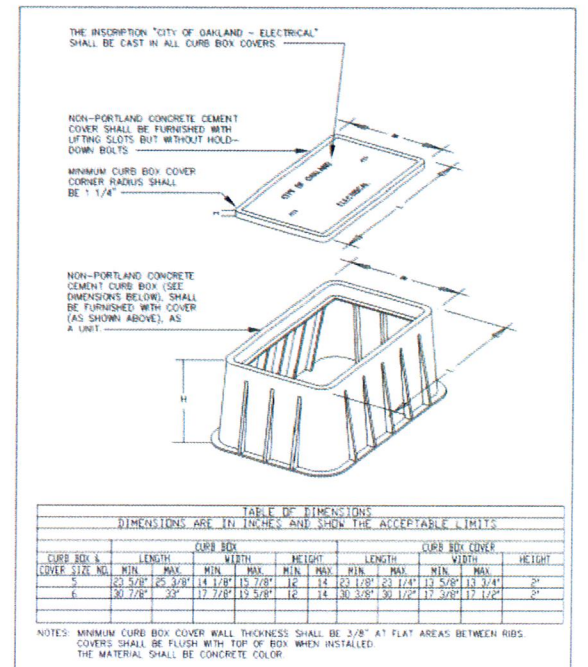

CITY OF OAKLAND DESIGN AND CONSTRUCTION SERVICES DEPARTMENT
 PRECAST NON-CONCRETE STANDARD CURB BOXES
 ELECTRICAL SERVICES MANAGER
 DATE: 03/20/19
 REV: 01/01/19
 E-9

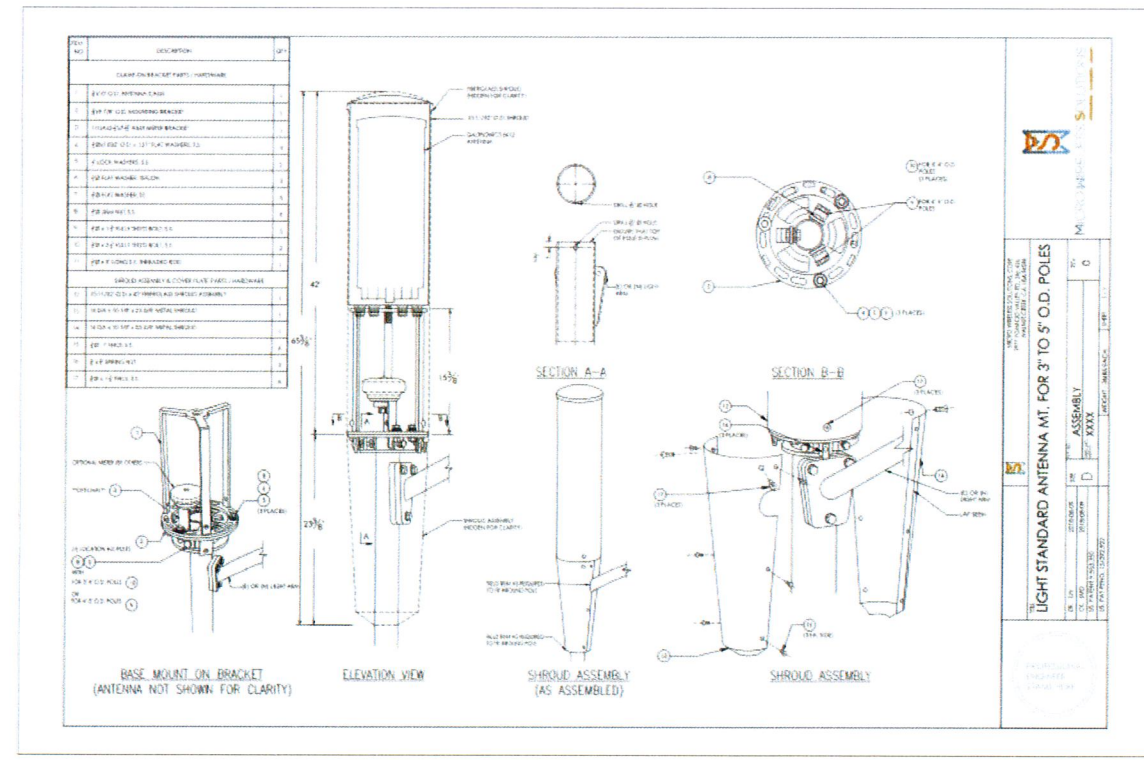

ANTENNA MOUNT AND SHROUD

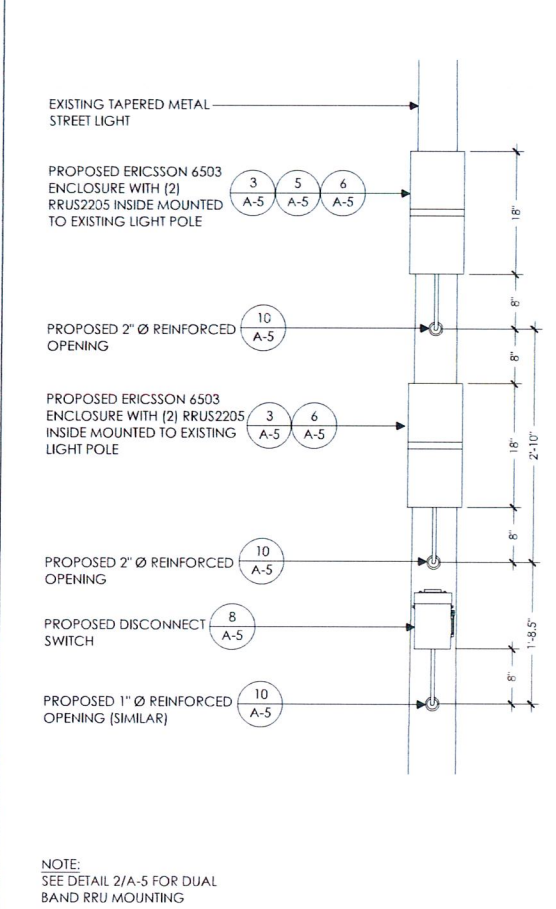
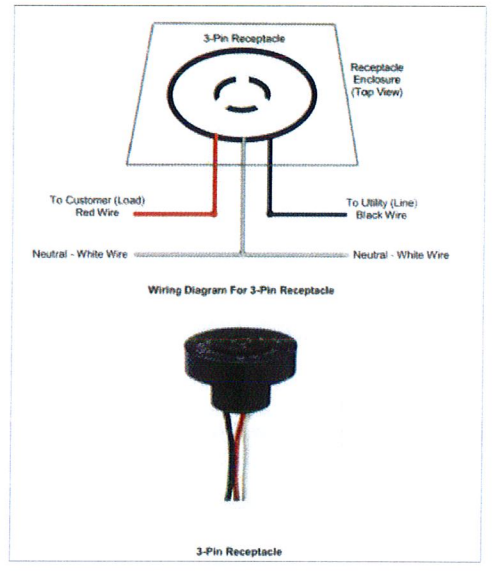
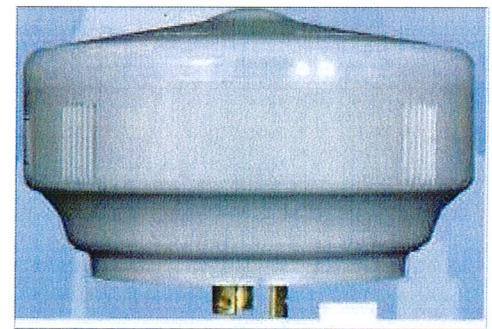

AT&T Wireless
 5001 Executive Parkway
 San Ramon, CA 94583

Client:



Project Architect:



375 LENNON LANE
 SUITE 125
 WALNUT CREEK, CA 94598
 T 925-482-8500

Site Agent:

100% Construction Drawings

Drawing Phase:

CRAN-RSFR-SFOK6-015
 ROW AT 66 LAKE MERRITT BLVD
 OAKLAND, CA 94612
 COUNTY: ALAMEDA

Site Name:



Professional Seal:
 It is a violation of law for any person, unless they are acting under the direction of a licensed Professional Architect/Engineer, to alter this document.

| Rev. | Date | Description |
|------|----------|-----------------------|
| 01 | 09/14/17 | Zoning Dwg 90% |
| 02 | 10/06/17 | Zoning Dwg 95% |
| 03 | 03/20/19 | Construction Dwg 100% |

Project No.:

Date: 03/20/19 Job No.:

Scale: AS SHOWN CAD File:

Designed By: JG Checked: RB

EQUIPMENT DETAILS

Sheet Title:

A.6

Sheet No.:

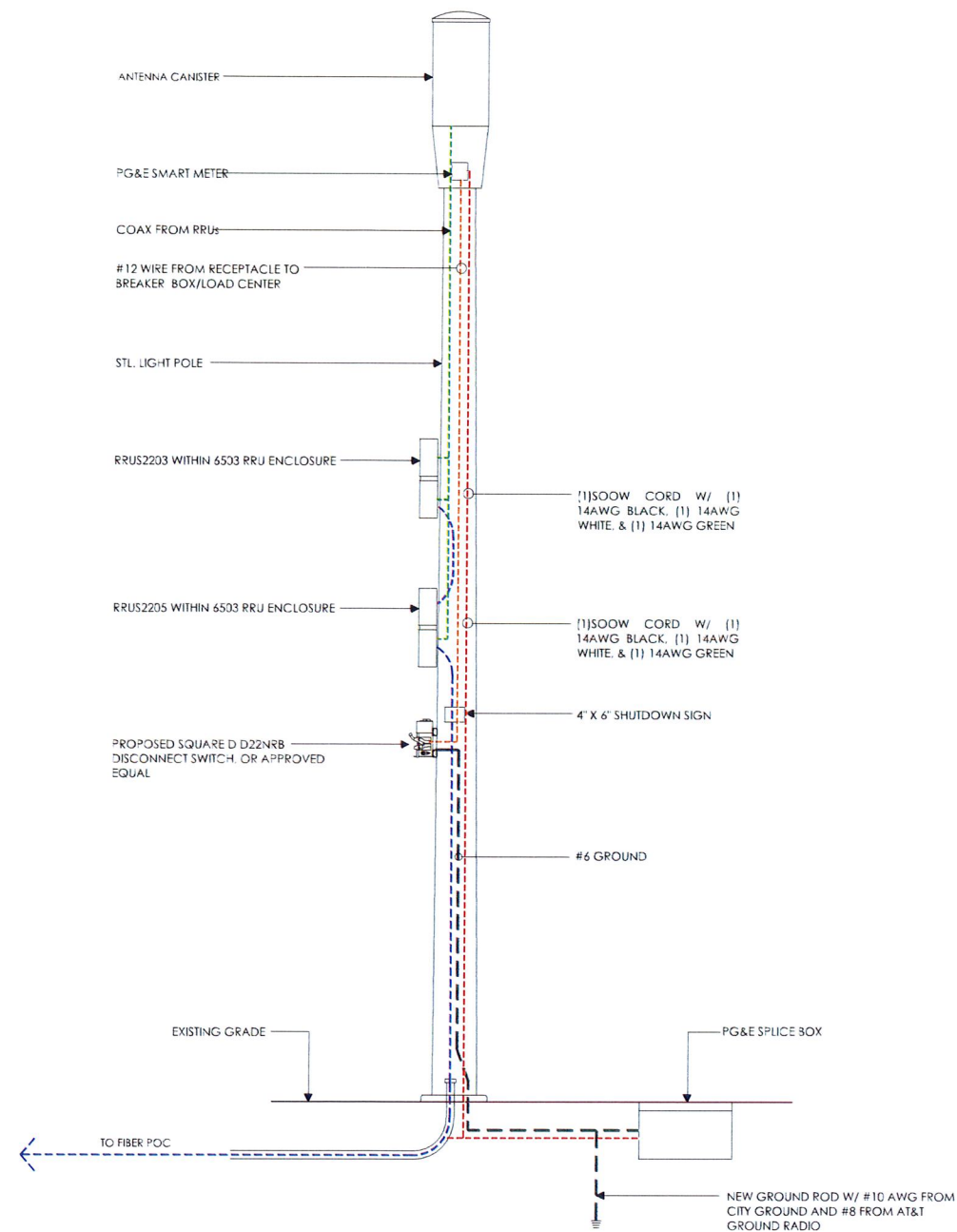

SINGLE LINE DIAGRAM , TYP.

LOAD CALCULATIONS - AT&T WIRELESS
 EXISTING LOAD: 0 AMPS
 NEW LOAD: 6.67 AMPS MAX.
 NEW TOTAL LOAD: 6.67 AMPS MAX.

POWER AND TELCO DESIGN IS BASED ON INITIAL SITE VISIT.
 CONTRACTOR SHALL OBTAIN CURRENT UTILITY COORDINATOR PLANS PRIOR TO START OF CONSTRUCTION.

AVAILABLE FAULT CURRENT PER UTILITY.
 NOTE: CONTRACTOR TO CHECK WITH UTILITY TO ENSURE ELEC. METER IS BRACED FOR ACTUAL FAULT CURRENT.

POWER AND TELCO NOTES:

1. POWER AND TELCO POINTS OF CONNECTION AND ANY EASEMENTS ARE PRELIMINARY AND SUBJECT TO CHANGE BY THE UTILITY COMPANIES.
2. CONTRACTOR SHALL COORDINATE WITH UTILITY COMPANY FOR FINAL AND EXACT WORK/MATERIALS REQUIREMENTS AND CONSTRUCT TO UTILITY ENGINEERING PLANS AND SPECIFICATIONS ONLY WHERE APPLICABLE PER PROJECT SCOPE OF WORK.
3. CONTRACTOR SHALL FURNISH AND INSTALL CONDUIT, PULL WIRES, CABLE PULL BOXES, CONCRETE ENCASUREMENT OF CONDUIT, TRANSFORMER PAD, BARRIERS, POLE RISER TRENCHING, BACK FILL, AND UTILITY FEES, AND INCLUDE REQUIREMENTS IN SCOPE.
4. CONTRACTOR SHALL LABEL ALL MAIN DISCONNECT SWITCHES AS REQUIRED BY CODE.

NOTES:

1. SUBCONTRACTOR SHALL PROVIDE DIST. PANEL AND BREAKERS FOR POWER TO EQUIPMENT.
2. ALL SERVICE EQUIPMENT AND INSTALLATIONS SHALL COMPLY WITH THE N.E.C. AND UTILITY COMPANY AND LOCAL CODE REQUIREMENTS.
3. SUBCONTRACTOR SHALL PROVIDE ELECTRICAL SERVICE ENTRANCE EQUIPMENT WITH FAULT CURRENT RATINGS GREATER THAN THE AVAILABLE FAULT CURRENT FROM THE POWER UTILITY.
4. MAXIMUM ONE WAY CIRCUIT RUN NOT TO EXCEED 75 FEET.

GENERAL ELECTRICAL NOTES:

1. PROVIDE ALL ELECTRICAL WORK & MATERIALS AS SHOWN ON THE DWGS. AS CALLED FOR HEREIN, & AS IS NECESSARY TO FURNISH A COMPLETE INSTALLATION.
2. THE INSTALLATION SHALL CONFORM TO THE REQUIREMENTS OF THE CURRENT ADOPTED CALIFORNIA ELECTRICAL CODE, STATE OF CALIFORNIA TITLE 24, ALL OTHER APPLICABLE CODES AND ORDINANCES & THE REQUIREMENTS OF THE FIRE MARSHALL. ALL EQUIPMENT & WIRING SHALL BEAR THE APPROVAL STAMP OF UNDERWRITERS LABORATORY (UL) OR AN APPROVED TESTING LABORATORY. PAYMENT FOR ALL INSPECTION FEES AND PERMITS ARE PART OF THIS CONTRACT.
3. THE CONTRACTOR SHALL BE RESPONSIBLE FOR THE SAFETY AND GOOD CONDITION OF ALL MATERIALS & EQUIPMENT FOR THE ENTIRE INSTALLATION & UNIT COMPLETION OF WORK. ERECT & MAINTAIN APPROVED & SUITABLE BARRIERS, PROTECTIVE DEVICES & WARNING SIGNS. BE FULLY RESPONSIBLE FOR ANY LOSS OR INJURY TO PERSONS OR PROPERTY RESULTING FROM NEGLIGENCE AND/OR ENFORCEMENT OF ALL SAFETY PRECAUTIONS & WARNINGS.
4. COORDINATE THE ELECTRICAL INSTALLATION WITH ALL OTHER TRADES.
5. ALL SAW CUTTING, TRENCHING, BACK FILLING & PATCHING SHALL BE PART OF THIS CONTRACT.
6. FINALIZE ALL ELECTRICAL SERVICE ARRANGEMENTS, INCLUDING VERIFICATION OF LOCATIONS, DETAILS, COORDINATION OF THE INSTALLATION & PAYMENT OF ACCRUED CHARGES WITH LOCAL POWER COMPANY. VERIFY LOCATION FOR FACILITIES & DETAILS WITH POWER UTILITY. IN ADDITION TO THE REQUIREMENTS SHOWN IN THE CONTRACT DOCUMENTS, WORK SHALL COMPLY WITH CONSTRUCTION STANDARDS & SERVICE REQUIREMENTS OF THE RESPECTIVE UTILITIES, INCLUDING ANY SUPPLEMENTAL DWGS ISSUED & SHALL BE SUBJECT TO APPROVAL OF THESE UTILITIES.
7. ALL WIRING SHALL BE COPPER. INSULATION FOR BRANCH CIRCUIT CONDUCTORS SHALL BE TYPE "THWN" CONDUCTORS LARGER AND #6 AWG MAY BE TYPE "THWN" OR "TWN".
8. PROVIDE CONDUIT SEALS FOR ALL CONDUITS PENETRATING WEATHERPROOFING OR WEATHERPROOF ENCLOSURE ENVELOPE. MASTIC SEAL ALL CONDUIT OPENING PENETRATIONS COMPLETELY WATERTIGHT.
9. UNLESS SHOWN OTHERWISE, FUSED DISCONNECT SWITCHES SHALL BE PROVIDED WITH LOW-PEAK, S/DUAL ELEMENT FUSES SIZED TO EQUIPMENT NAMEPLATE FUSE CURRENT RATING. MOTOR STARTERS SHALL BE PROVIDED WITH SIMILARLY SIZED FUSIBLE ELEMENTS. SWITCHES AND OTHER OUTDOOR EQUIPMENT SHALL BE RATED NEMA 3R AND/OR UL LISTED FOR WET ENVIRONMENT.
10. THE CONTRACTOR SHALL BE RESPONSIBLE FOR TESTING THE GROUNDING SYSTEM AND ENSURING A 5 OHM OR LESS GROUNDING PATH. ADDITIONAL GROUND RODS AND/OR CHEMICAL ROD SYSTEM SHALL BE USED TO ACHIEVE THIS REQUIREMENT IF THE GIVEN DESIGN CANNOT BE MADE TO ACHIEVE THIS REQUIREMENT.



AT&T Wireless
 5001 Executive Parkway
 San Ramon, CA 94583

Client:



Project Architect:



Site Agent:

100% Construction Drawings

Drawing Phase:

CRAN-RSFR-SFOK6-015
 PAGE ID:
 ROW AT 66 LAKE MERRITT BLVD
 OAKLAND, CA 94612
 COUNTY: ALAMEDA

Site Name:



Professional Seal:

It is a violation of law for any person, unless they are acting under the direction of a licensed Professional Architect/Engineer, to alter this document.

| Rev. | Date | Description |
|------|----------|-----------------------|
| 01 | 09/14/17 | Zoning Dwg 90% |
| 02 | 10/06/17 | Zoning Dwg 95% |
| 03 | 03/20/19 | Construction Dwg 100% |

Project No.:

Date: 03/20/19 Job No.:

Scale: AS SHOWN CAD File:

Designed By: JG Checked: RB

SINGLE LINE BUSS DIAGRAM

Sheet Title:

E.1

Sheet No.:

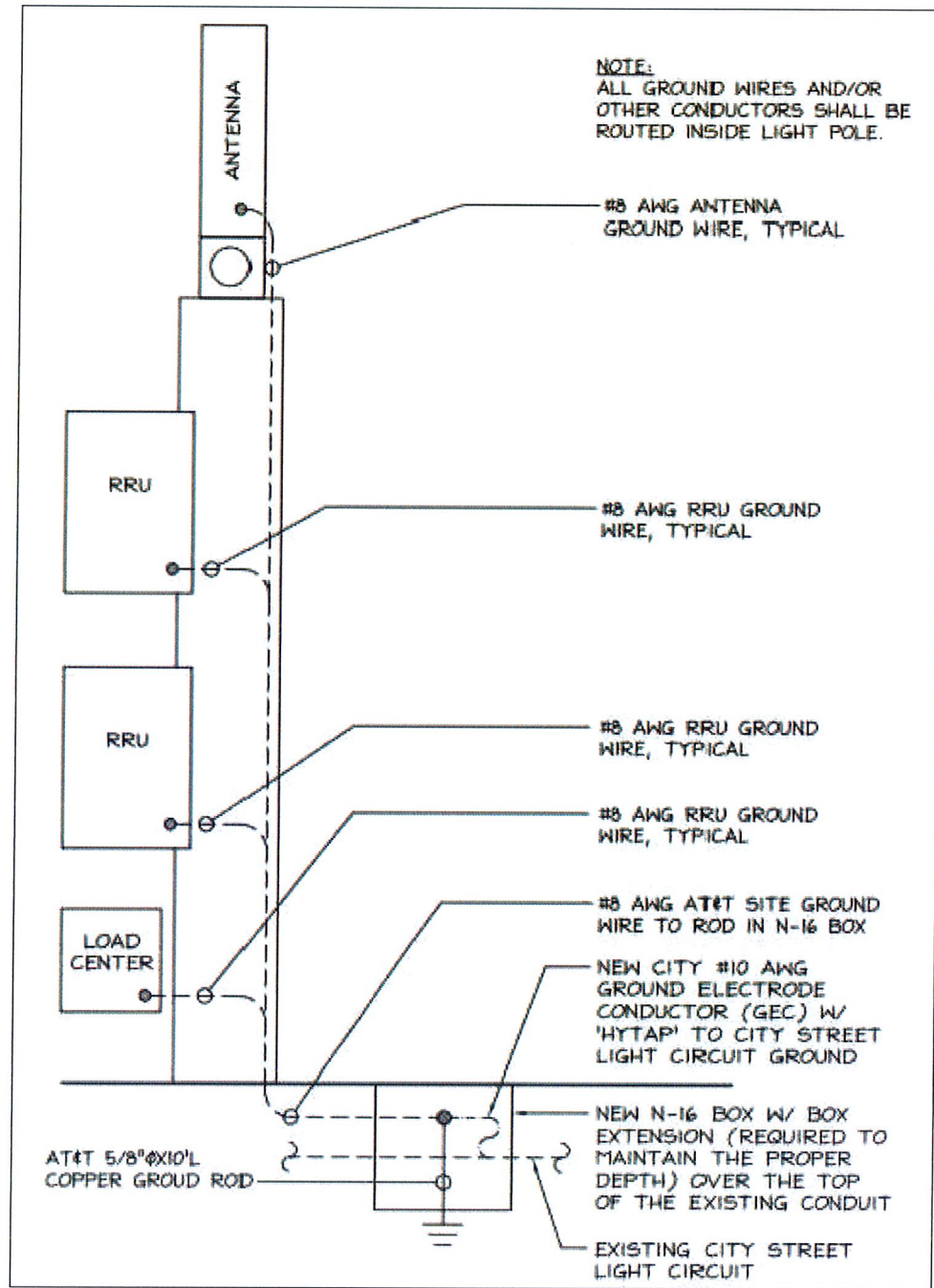

POLE GROUNDING RISER DIAGRAM (TYP.)

SCALE
N.T.S.

WIRING SCHEMATIC (TYP.)

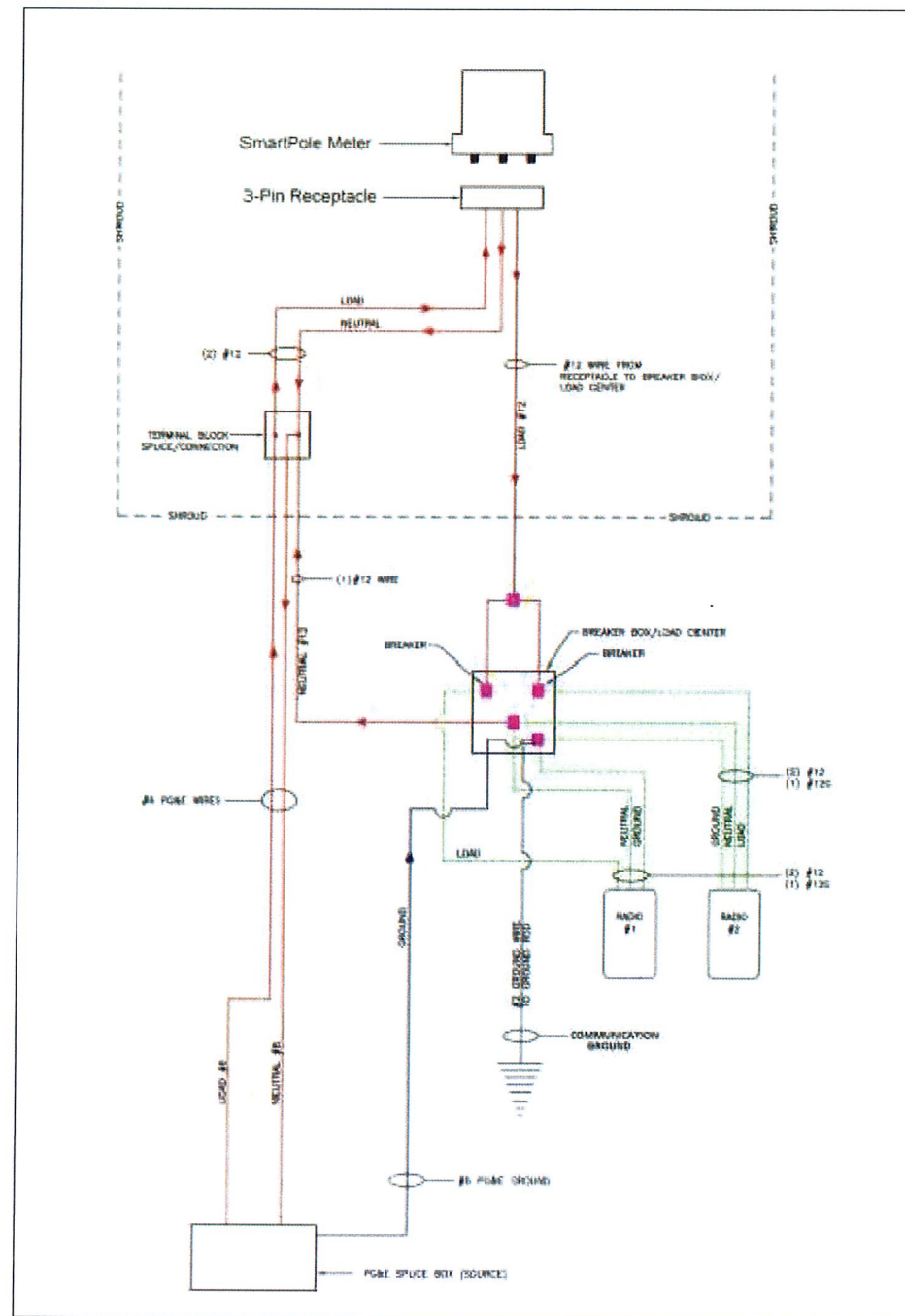

AT&T Wireless
5001 Executive Parkway
San Ramon, CA 94583

Client:



Project Architect:



375 LENNON LANE
SUITE 125
WALNUT CREEK, CA 94598
T 925.482.8500

Site Agent:

100% Construction
Drawings

Drawing Phase:

CRAN-RSFR-SFOK6-015
PAGE ID:
ROW AT 66 LAKE MERRITT BLVD
OAKLAND, CA 94612
COUNTY: ALAMEDA

Site Name:



Professional Seal:

It is a violation of law for any person,
unless they are acting under the direction
of a licensed Professional
Architect/Engineer, to alter this document.

| Rev. | Date | Description |
|------|----------|-----------------------|
| 01 | 09/14/17 | Zoning Dwg 90% |
| 02 | 10/06/17 | Zoning Dwg 95% |
| 03 | 03/20/19 | Construction Dwg 100% |

Project No.:

Date: 03/20/19 Job No.:

Scale: AS SHOWN CAD File:

Designed By: JG Checked: RB

ELECTRICAL PLAN, POLE
GROUNDING
ELECTRICAL DETAILS

Sheet Title:

E.2

Sheet No.:

Existing

view from Lake Merritt Boulevard looking east at site

 **AT&T Wireless** CRAN-RSFR-SFOK6-015
ROW at 66 Lake Merritt Boulevard, Oakland, CA
Photosims Produced on 9-22-2017

Proposed



Existing



Proposed



view from Lake Merritt Boulevard looking northwest at site

AdvanceSim 
Photo Simulation Solutions
Contact (925) 202-8507



AT&T Wireless

CRAN-RSFR-SFOK6-015

ROW at 66 Lake Merritt Boulevard, Oakland, CA

Photosims Produced on 9-22-2017

Alternative Site Analysis – SFOK6_015

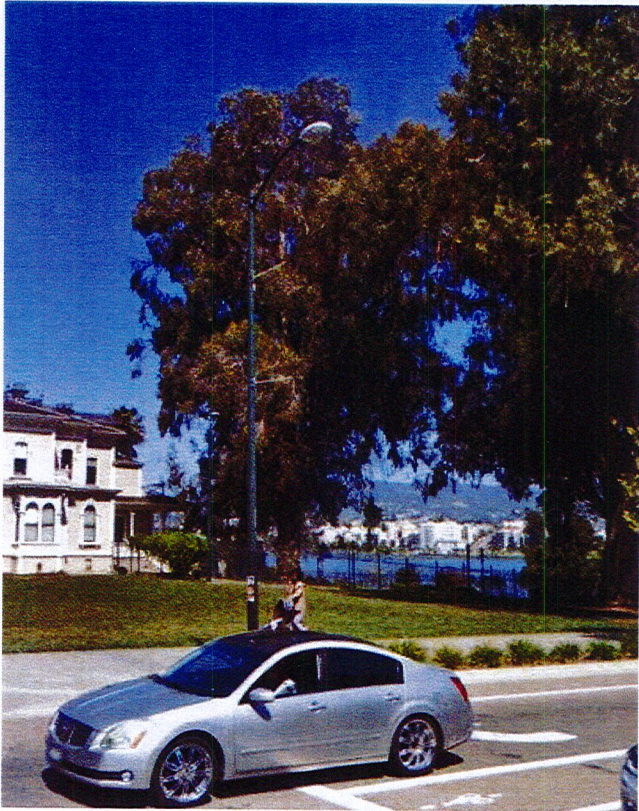

Node 15A

- Primary candidate
- Preferred due to adjacent commercial use and for best meeting AT&T's RF needs.



Node 15B:

- Potentially viable alternative
- Less preferred due to adjacent residential use.



Node 15C:

- Potentially viable alternative
- Less preferred as tree may partially block signal rendering making this site less desirable for RF.

Alternative Design Analysis



Full-Sized Tower:

- Too big/bulky.
- Requires 300' sq. area.
- Does not nestle coverage/capacity.



Shrouded Pole Equipment:

- Too big/bulky.
- Adds unnecessary equipment.
- Small cell equipment is already sleek.

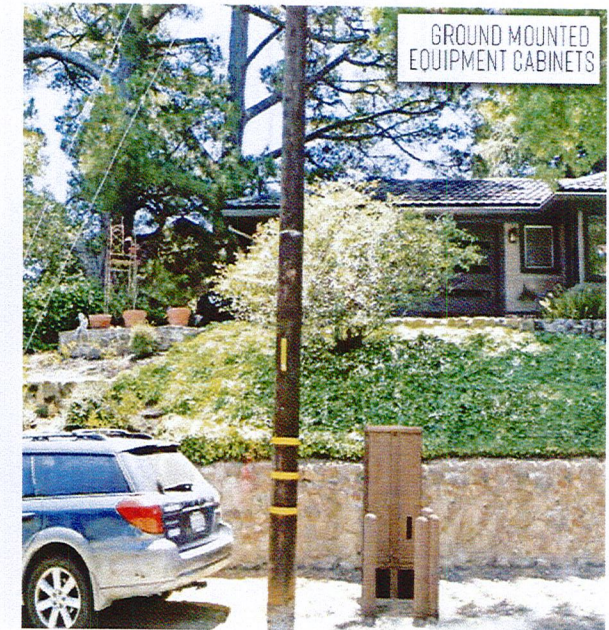

Equipment Cabinet:

- Too big/bulky.
- Adds unnecessary ROW equipment.
- Pole-mounted equipment blends in with pole.

AT&T Mobility • Proposed Small Cell (No. CRAN-RSFR-SFOK6-015)
66 Lake Merritt Boulevard • Oakland, California

Statement of Hammett & Edison, Inc., Consulting Engineers

The firm of Hammett & Edison, Inc., Consulting Engineers, has been retained on behalf of AT&T Mobility, a personal wireless telecommunications carrier, to evaluate its small cell (No. CRAN-RSFR-SFOK6-015) proposed to be sited in Oakland, California, for compliance with appropriate guidelines limiting human exposure to radio frequency (“RF”) electromagnetic fields.

Executive Summary

AT&T proposes to install an omnidirectional cylindrical antenna on a light pole sited in the public right-of-way at 66 Lake Merritt Boulevard in Oakland. The proposed operation will comply with the FCC guidelines limiting public exposure to RF energy.

Prevailing Exposure Standards

The U.S. Congress requires that the Federal Communications Commission (“FCC”) evaluate its actions for possible significant impact on the environment. A summary of the FCC’s exposure limits is shown in Figure 1. These limits apply for continuous exposures and are intended to provide a prudent margin of safety for all persons, regardless of age, gender, size, or health. The most restrictive FCC limit for exposures of unlimited duration to radio frequency energy for several personal wireless services are as follows:

| Wireless Service | Frequency Band | Occupational Limit | Public Limit |
|------------------------------------|------------------|-------------------------|-------------------------|
| Microwave (Point-to-Point) | 5,000–80,000 MHz | 5.00 mW/cm ² | 1.00 mW/cm ² |
| BRS (Broadband Radio) | 2,600 | 5.00 | 1.00 |
| AWS (Advanced Wireless) | 2,100 | 5.00 | 1.00 |
| PCS (Personal Communication) | 1,950 | 5.00 | 1.00 |
| Cellular | 870 | 2.90 | 0.58 |
| SMR (Specialized Mobile Radio) | 855 | 2.85 | 0.57 |
| 700 MHz | 700 | 2.35 | 0.47 |
| [most restrictive frequency range] | 30–300 | 1.00 | 0.20 |

General Facility Requirements

Small cells typically consist of two distinct parts: the electronic transceivers (also called “radios”) that are connected to the traditional wired telephone lines, and the passive antennas that send the wireless signals created by the radios out to be received by individual subscriber units. The transceivers are typically mounted on the support pole or placed in a cabinet at ground level, and they are connected to the antennas by coaxial cables. Because of the short wavelength of the frequencies assigned by the FCC for wireless services, the antennas require line-of-sight paths for their signals to propagate well and so are installed at some height above ground. The antennas are designed to concentrate their energy toward the horizon, with very little energy wasted toward the sky or the ground. This means



AT&T Mobility • Proposed Small Cell (No. CRAN-RSFR-SFOK6-015)
66 Lake Merritt Boulevard • Oakland, California

that it is generally not possible for exposure conditions to approach the maximum permissible exposure limits without being physically very near the antennas.

Computer Modeling Method

The FCC provides direction for determining compliance in its Office of Engineering and Technology Bulletin No. 65, "Evaluating Compliance with FCC-Specified Guidelines for Human Exposure to Radio Frequency Radiation," dated August 1997. Figure 2 attached describes the calculation methodologies, reflecting the facts that a directional antenna's radiation pattern is not fully formed at locations very close by (the "near-field" effect) and that at greater distances the power level from an energy source decreases with the square of the distance from it (the "inverse square law"). The conservative nature of this method for evaluating exposure conditions has been verified by numerous field tests.

Site and Facility Description

Based upon information provided by AT&T, including drawings by Meridian Management LLC, dated September 14, 2017, it is proposed to install one Galtronics Model P6480, 2-foot tall, omnidirectional cylindrical antenna, on top of an existing light pole sited in the public right-of-way at the east corner of the intersection between Lakeside Drive and Lake Merritt Boulevard in Oakland. The antenna would employ no downtilt and would be mounted at an effective height of about 27½ feet above ground. The maximum effective radiated power in any direction would be 80 watts for PCS service. There are reported no other wireless telecommunications base stations at this site or nearby.

Study Results

For a person anywhere at ground, the maximum RF exposure level due to the proposed AT&T operation is calculated to be 0.0011 mW/cm², which is 0.11% of the applicable public exposure limit. The maximum calculated level at any nearby building is 0.29% of the public exposure limit. It should be noted that these results include several "worst-case" assumptions and therefore are expected to overstate actual power density levels from the proposed operation.

No Recommended Mitigation Measures

Due to its mounting location and height, the AT&T antenna would not be accessible to the general public, and so no mitigation measures are necessary to comply with the FCC public exposure guidelines. The occupational limit is calculated to extend 4 inches from the antenna and, due to this short distance, the proposed operation is considered intrinsically compliant with that limit.

**AT&T Mobility • Proposed Small Cell (No. CRAN-RSFR-SFOK6-015)
66 Lake Merritt Boulevard • Oakland, California**

Conclusion

Based on the information and analysis above, it is the undersigned's professional opinion that operation of the small cell proposed by AT&T Mobility at 66 Lake Merritt Boulevard in Oakland, California, will comply with the prevailing standards for limiting public exposure to radio frequency energy and, therefore, will not for this reason cause a significant impact on the environment. The highest calculated level in publicly accessible areas is much less than the prevailing standards allow for exposures of unlimited duration. This finding is consistent with measurements of actual exposure conditions taken at other operating small cells.

Authorship

The undersigned author of this statement is a qualified Professional Engineer, holding California Registration Nos. E-13026 and M-20676, which expire on June 30, 2019. This work has been carried out under his direction, and all statements are true and correct of his own knowledge except, where noted, when data has been supplied by others, which data he believes to be correct.



William F. Hammett
William F. Hammett, P.E.

707/996-5200

November 15, 2017

FCC Radio Frequency Protection Guide

The U.S. Congress required (1996 Telecom Act) the Federal Communications Commission (“FCC”) to adopt a nationwide human exposure standard to ensure that its licensees do not, cumulatively, have a significant impact on the environment. The FCC adopted the limits from Report No. 86, “Biological Effects and Exposure Criteria for Radiofrequency Electromagnetic Fields,” published in 1986 by the Congressionally chartered National Council on Radiation Protection and Measurements (“NCRP”). Separate limits apply for occupational and public exposure conditions, with the latter limits generally five times more restrictive. The more recent standard, developed by the Institute of Electrical and Electronics Engineers and approved as American National Standard ANSI/IEEE C95.1-2006, “Safety Levels with Respect to Human Exposure to Radio Frequency Electromagnetic Fields, 3 kHz to 300 GHz,” includes similar limits. These limits apply for continuous exposures from all sources and are intended to provide a prudent margin of safety for all persons, regardless of age, gender, size, or health.

As shown in the table and chart below, separate limits apply for occupational and public exposure conditions, with the latter limits (in *italics* and/or dashed) up to five times more restrictive:

| Frequency Applicable Range (MHz) | Electromagnetic Fields (<i>f</i> is frequency of emission in MHz) | | | | | |
|---|--|----------------|-------------------------------------|-----------------|--|--------------------------|
| | Electric Field Strength (V/m) | | Magnetic Field Strength (A/m) | | Equivalent Far-Field Power Density (mW/cm ²) | |
| 0.3 – 1.34 | 614 | <i>614</i> | 1.63 | <i>1.63</i> | 100 | <i>100</i> |
| 1.34 – 3.0 | 614 | <i>823.8/f</i> | 1.63 | <i>2.19/f</i> | 100 | <i>180/f²</i> |
| 3.0 – 30 | 1842/ <i>f</i> | <i>823.8/f</i> | 4.89/ <i>f</i> | <i>2.19/f</i> | 900/ <i>f²</i> | <i>180/f²</i> |
| 30 – 300 | 61.4 | <i>27.5</i> | 0.163 | <i>0.0729</i> | 1.0 | <i>0.2</i> |
| 300 – 1,500 | 3.54√ <i>f</i> | <i>1.59√f</i> | √ <i>f</i> /106 | √ <i>f</i> /238 | <i>f</i> /300 | <i>f</i> /1500 |
| 1,500 – 100,000 | 137 | <i>61.4</i> | 0.364 | <i>0.163</i> | 5.0 | <i>1.0</i> |

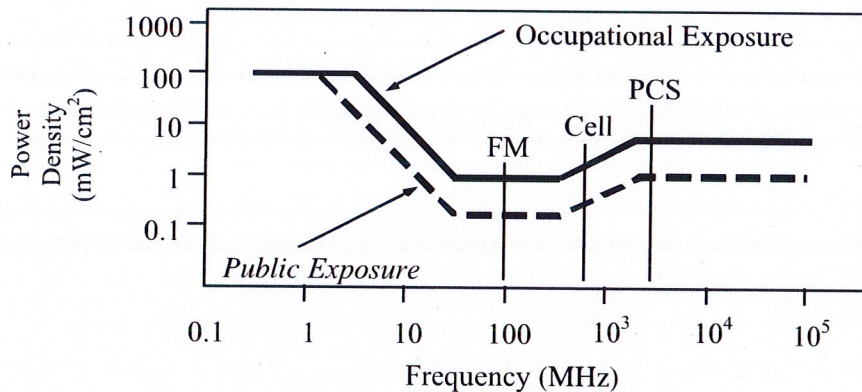

Higher levels are allowed for short periods of time, such that total exposure levels averaged over six or thirty minutes, for occupational or public settings, respectively, do not exceed the limits, and higher levels also are allowed for exposures to small areas, such that the spatially averaged levels do not exceed the limits. However, neither of these allowances is incorporated in the conservative calculation formulas in the FCC Office of Engineering and Technology Bulletin No. 65 (August 1997) for projecting field levels. Hammett & Edison has built those formulas into a proprietary program that calculates, at each location on an arbitrary rectangular grid, the total expected power density from any number of individual radio sources. The program allows for the description of buildings and uneven terrain, if required to obtain more accurate projections.



RFR.CALC™ Calculation Methodology

Assessment by Calculation of Compliance with FCC Exposure Guidelines

The U.S. Congress required (1996 Telecom Act) the Federal Communications Commission ("FCC") to adopt a nationwide human exposure standard to ensure that its licensees do not, cumulatively, have a significant impact on the environment. The maximum permissible exposure limits adopted by the FCC (see Figure 1) apply for continuous exposures from all sources and are intended to provide a prudent margin of safety for all persons, regardless of age, gender, size, or health. Higher levels are allowed for short periods of time, such that total exposure levels averaged over six or thirty minutes, for occupational or public settings, respectively, do not exceed the limits.

Near Field.

Prediction methods have been developed for the near field zone of panel (directional) and whip (omnidirectional) antennas, typical at wireless telecommunications base stations, as well as dish (aperture) antennas, typically used for microwave links. The antenna patterns are not fully formed in the near field at these antennas, and the FCC Office of Engineering and Technology Bulletin No. 65 (August 1997) gives suitable formulas for calculating power density within such zones.

For a panel or whip antenna, power density $S = \frac{180}{\theta_{BW}} \times \frac{0.1 \times P_{net}}{\pi \times D \times h}$, in mW/cm²,

and for an aperture antenna, maximum power density $S_{max} = \frac{0.1 \times 16 \times \eta \times P_{net}}{\pi \times h^2}$, in mW/cm²,

where θ_{BW} = half-power beamwidth of the antenna, in degrees, and
 P_{net} = net power input to the antenna, in watts,
 D = distance from antenna, in meters,
 h = aperture height of the antenna, in meters, and
 η = aperture efficiency (unitless, typically 0.5-0.8).

The factor of 0.1 in the numerators converts to the desired units of power density.

Far Field.

OET-65 gives this formula for calculating power density in the far field of an individual RF source:

$$\text{power density } S = \frac{2.56 \times 1.64 \times 100 \times RFF^2 \times ERP}{4 \times \pi \times D^2}, \text{ in mW/cm}^2,$$

where ERP = total ERP (all polarizations), in kilowatts,
RFF = relative field factor at the direction to the actual point of calculation, and
D = distance from the center of radiation to the point of calculation, in meters.

The factor of 2.56 accounts for the increase in power density due to ground reflection, assuming a reflection coefficient of 1.6 (1.6 x 1.6 = 2.56). The factor of 1.64 is the gain of a half-wave dipole relative to an isotropic radiator. The factor of 100 in the numerator converts to the desired units of power density. This formula has been built into a proprietary program that calculates, at each location on an arbitrary rectangular grid, the total expected power density from any number of individual radiation sources. The program also allows for the description of uneven terrain in the vicinity, to obtain more accurate projections.



Utility Contact System Search

The Utility Contact System (UCS) is the Communications Division's database for the primary regulatory contact for each telephone corporation operating in California. The Communications Division sends important regulatory notices to the regulatory contact for each telephone corporation via e-mail, so it is important for primary regulatory contacts to update their UCS record if their e-mail address changes.

Telephone corporations may update UCS contact information using the form on the following page: [Carrier Reporting Requirements](#)

A description of the different utility types (granted authorities) are listed on the following page: [Utility Type Descriptions](#)

Search Utility Name Search Utility Number Search

| Utility Name ▲ | Alias (DBA Name) | Utility Number | Street Address | City | State | Zip | Phone Number | Email | Utility Type | CPCN Appro |
|--------------------------------|-------------------|----------------|----------------------------------|------------------|-------|-------|----------------|------------------------------------|--------------|------------|
| New Cingular Wireless Pcs, LLC | CINGULAR WIRELESS | 3060 | 430 BUSH STREET | SAN FRANCISCO | CA | 94108 | (415) 778-1299 | att-regulatory-ca@att.com | CEC | 12-21-1995 |
| New Cingular Wireless Pcs, LLC | CINGULAR WIRELESS | 3060 | 7405 GREENHAVEN DRIVE | SACRAMENTO | CA | 95831 | (800) 498-1912 | west.region.oopsac@awsmail.att.com | CEC | 12-21-1995 |
| New Cingular Wireless Pcs, LLC | CINGULAR WIRELESS | 3060 | 11760 US HIGHWAY ONE, WEST TOWER | NORTH PALM BEACH | FL | 33048 | 770-240-8849 | | CEC | 12-21-1995 |

[Save Search Results as CSV Spreadsheet](#)

[Comments & Feedback](#)



PUBLIC NOTICE

CITY OF OAKLAND



CITY OF OAKLAND
Planning and Building Department
Bureau of Planning



A.3

12:00 AM
3:00 AM
MON WED FRI
EACH MONTH
STREET SWEEPING

2 HOUR
PARKING
8 A.M. TO 6 P.M.
EXCEPT SUNDAY

PUBLIC NOTICE
CITY OF OAKLAND
CITY OF OAKLAND
Planning and Building Department
Office of Planning



Handwritten graffiti on the pole, including the letters 'CCH'.

Handwritten graffiti on the pole, including the word 'WAVE'.

White painted arrow and text on the sidewalk.

GRAND TROUSERS

PUBLIC CITY



CITY OF OAKLAND
Planning and Building Department
Bureau of Planning

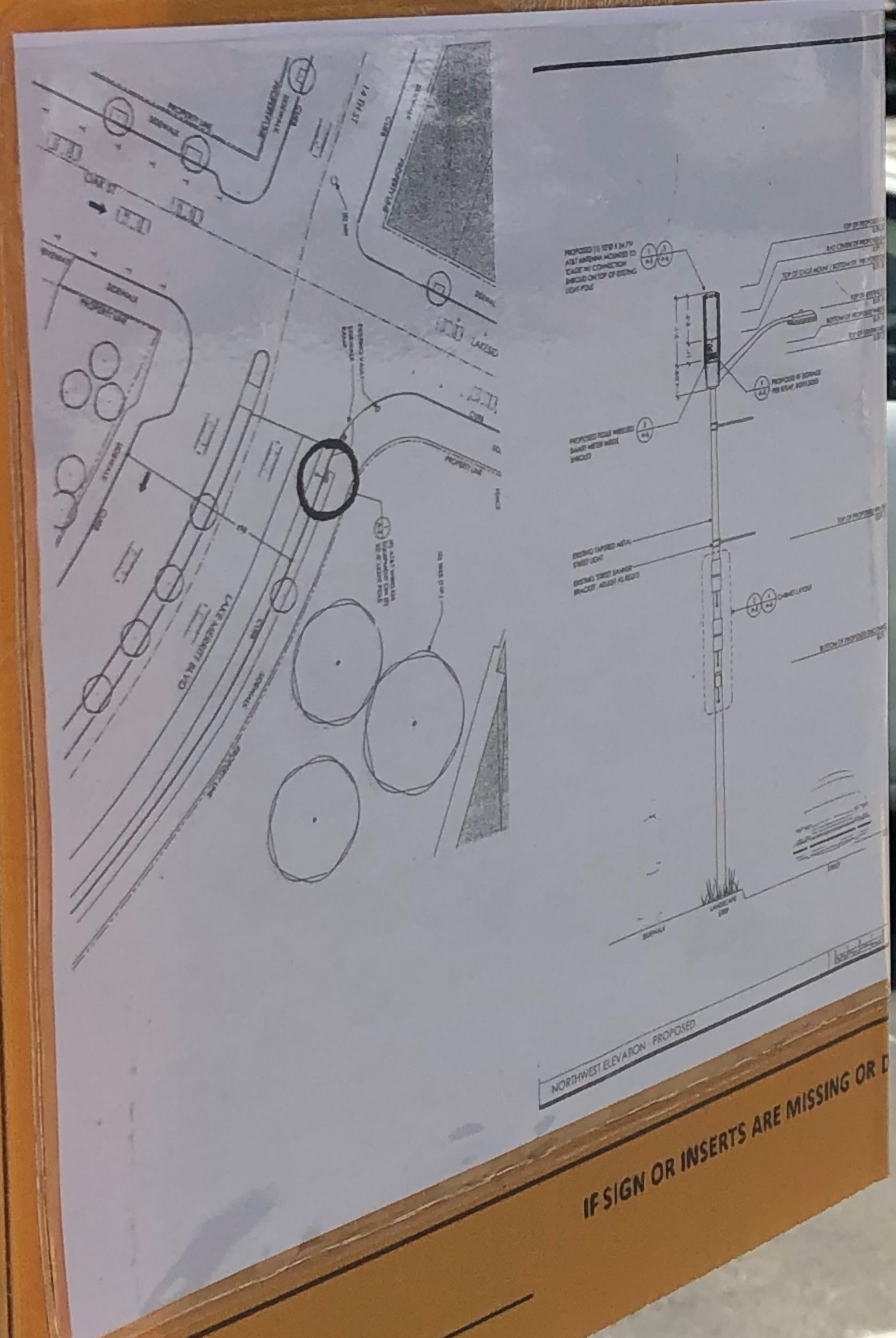

IF SIGN OR INSERTS ARE MISSING OR

SIGN NUMBER: _____



PUBLIC NOTICE
CITY OF OAKLAND



CITY OF OAKLAND
Planning and Building Department
Bureau of Planning



AT&T
A.3

OR DAMAGED, PLEASE CALL ZONING AT (510) 238-3

PUBLIC NOTICE
CITY OF OAKLAND

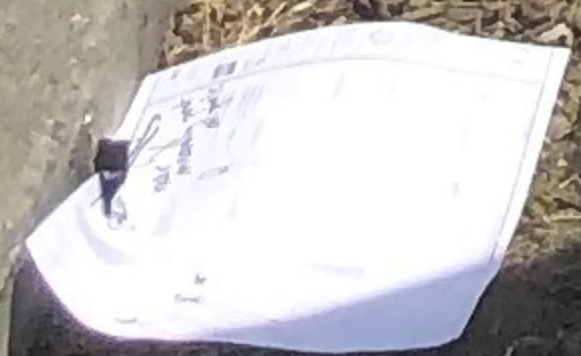

NO
PARKING
12am-3am
STREET SWEEPING
EXCEPT SUNDAYS AND HOLIDAYS

1006

14th
Lake Merritt



PUBLIC

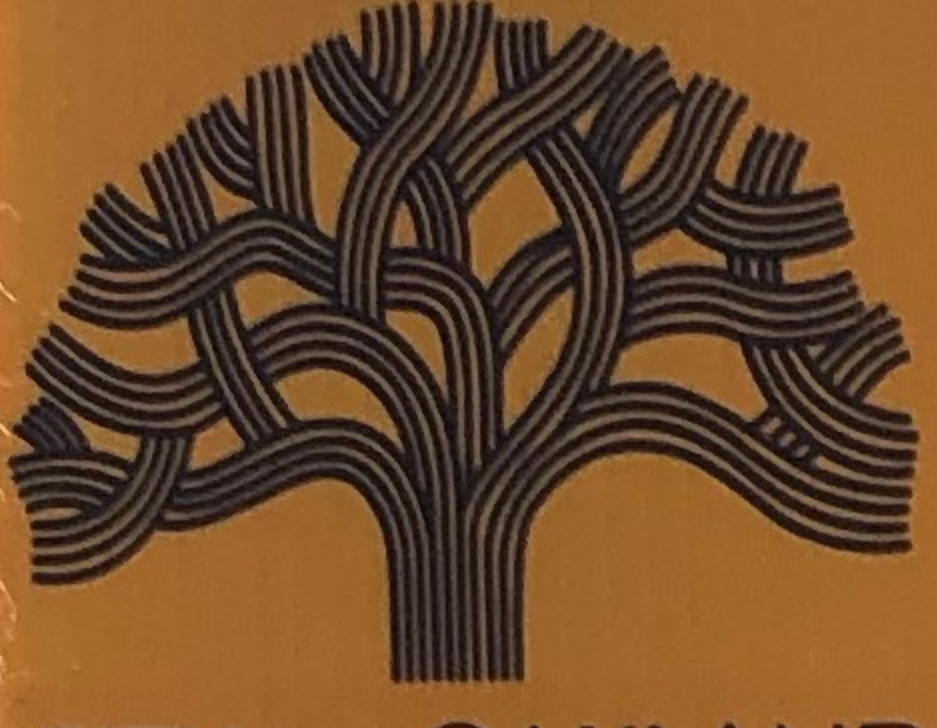

CITY

CITY OF OAKLAND
Planning and Building Department
Bureau of Planning

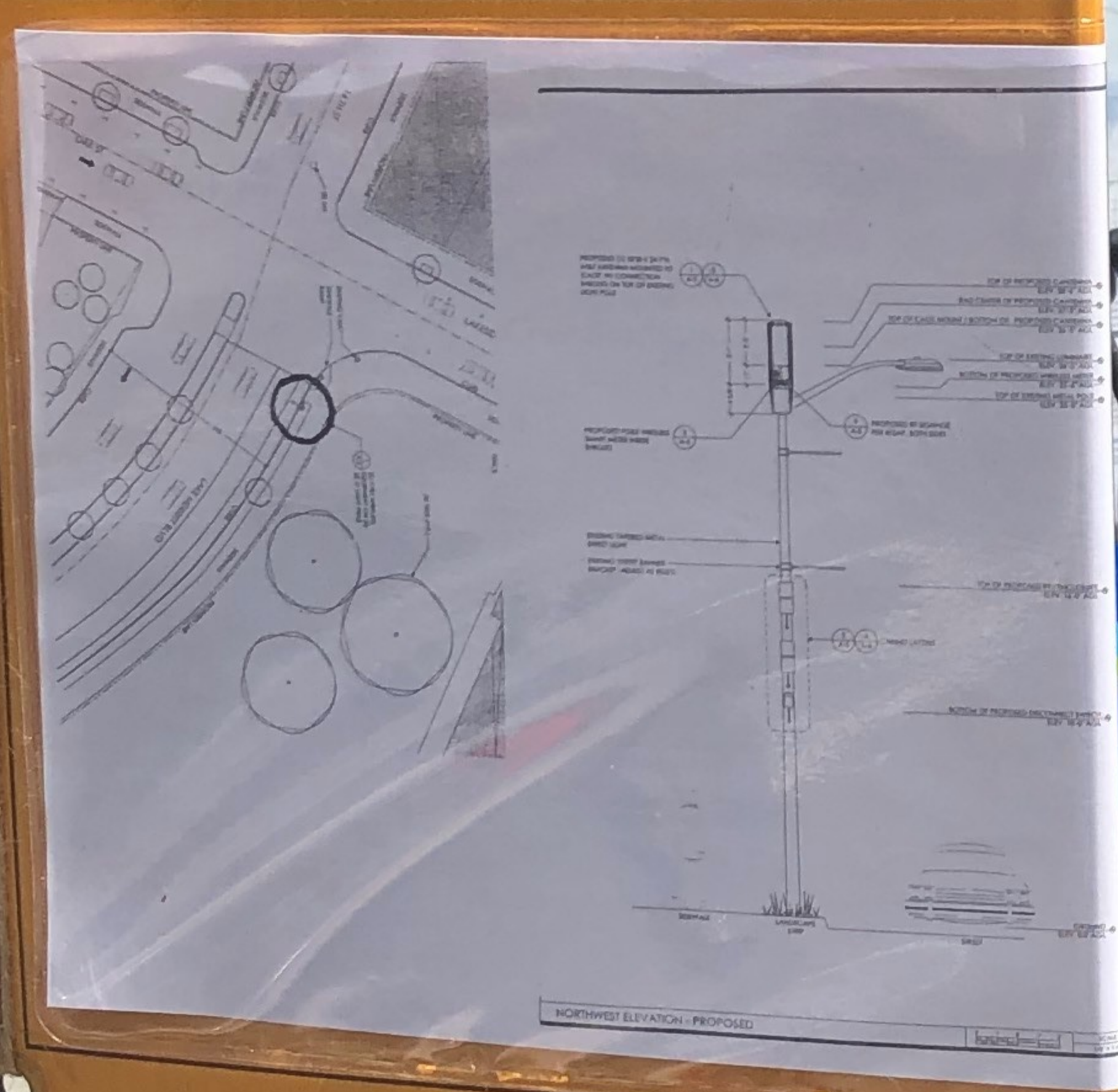

SIGN NUMBER: _____ IF SIGN OR INSERTS ARE MISSING OR DAMAGED

Handwritten graffiti on the pole: 'CITY'

Handwritten graffiti on the pole: 'CITY'

Informational sign for 'Ford GoBike' at 'Lakeside Dr at 14th St'. It features a map of the area and the 'clover' logo.



A large GoBike station with a screen and a bike dock. It is labeled 'Ford GoBike' and 'Lakeside Dr at 14th St'.



Handwritten graffiti on the sidewalk: 'CITY'



AT&T

AT&T OPEN HOUSE



AT&T is improving wireless service in Oakland!

We will soon be proposing state-of-the-art small cell wireless facilities including antennas, attached to existing utility poles and light poles.

Want to learn more?

Please join us for an open house showcasing AT&T's network, designs, permitting and radio frequency engineering.

Monday, January 22nd, 2018

Open House—Stop by anytime between 6pm–8pm

Light refreshments served

*Lake Merritt United Methodist Church
1255 First Ave., Oakland, CA 94606*

If you have any questions, please feel free to contact:

*oaklandoutreach@vinculums.com
(925) 482-8550*

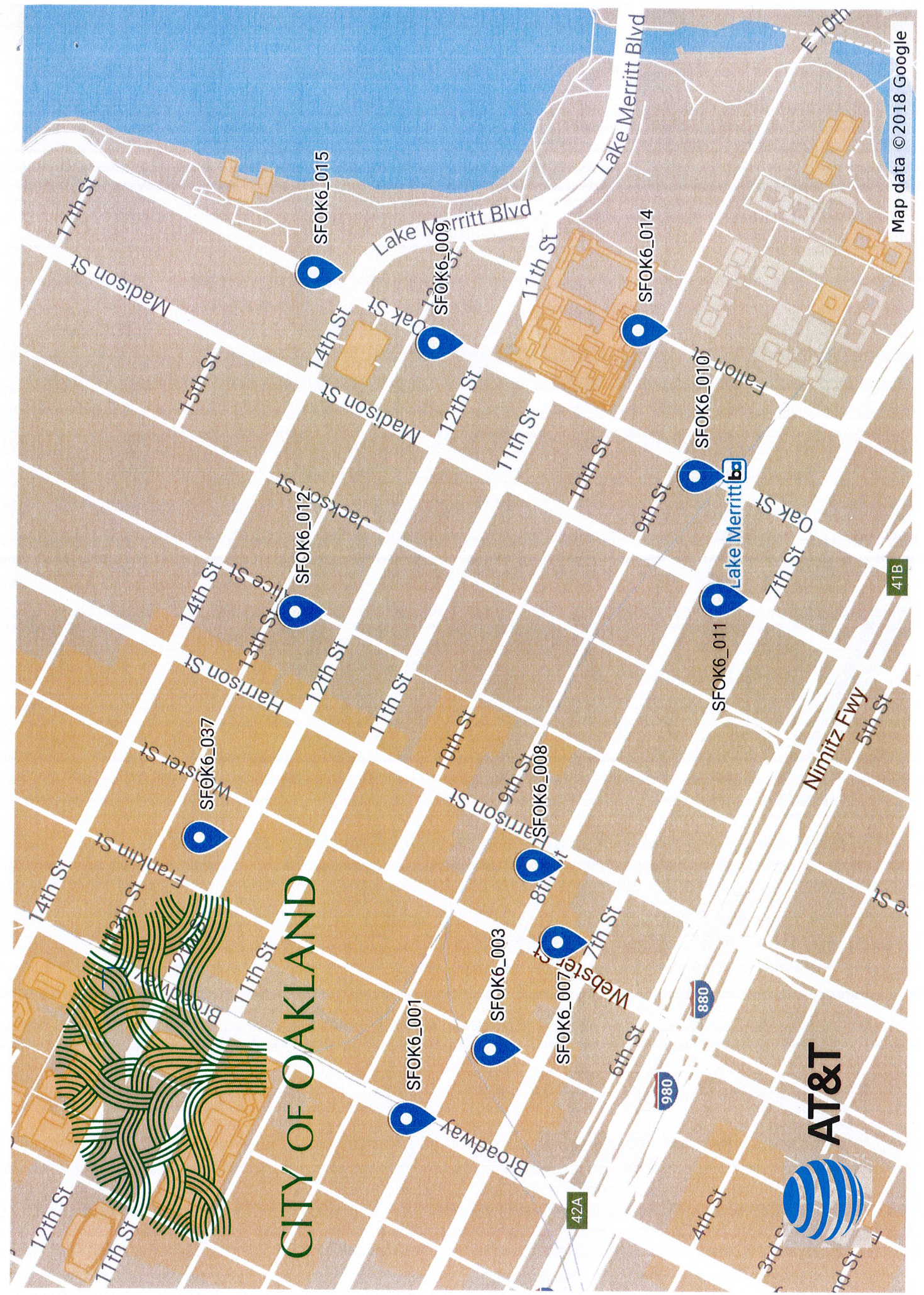
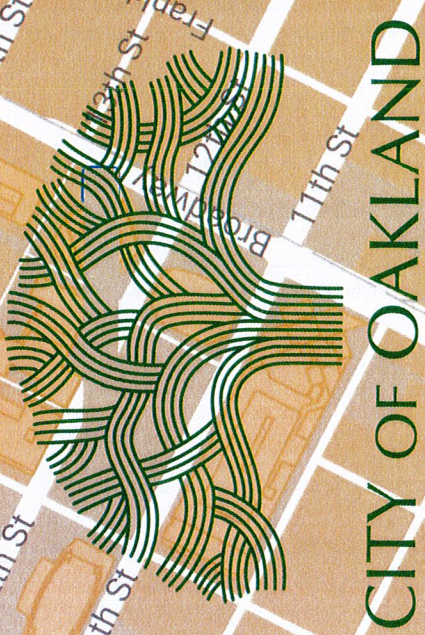

AT&T Small Cell Community Meeting Sign In

Project: Oakland Council District #2
 Facilitator: Vinculums Servicess
 Place/Room: Lake Merritt United Methodist Church
Stark Room

Date: 1/22/2018
 Time: 6pm-8pm

| | PRINT NAME | ORGANIZATION | PHONE | EMAIL |
|-----|----------------|--------------|--------------|-------------------------|
| 1. | Mary K. Ryan | | 510 928-0623 | midnight_lowl@yahoo.com |
| 2. | Marquita Parce | | | |
| 3. | Alex Chang | | | |
| 4. | M. Downing | | | |
| 5. | | | | |
| 6. | | | | |
| 7. | | | | |
| 8. | | | | |
| 9. | | | | |
| 10. | | | | |
| 11. | | | | |
| 12. | | | | |
| 13. | | | | |
| 14. | | | | |
| 15. | | | | |
| 16. | | | | |
| 17. | | | | |
| 18. | | | | |
| 19. | | | | |
| 20. | | | | |
| 21. | | | | |
| 22. | | | | |

Klein, Heather

From: Johanna Finney <johannafinney@gmail.com>
Sent: Wednesday, May 1, 2019 2:56 PM
To: Klein, Heather
Cc: Alexis or Ned Schroeder; Chen, Miya Saika; jmyres.oakplanningcommission@gmail.com
Subject: Telecommunications Facility at Lake Merritt 0.5 miles from State Bird Sanctuary

Hello Heather,

Since you are the planner on this cell antenna application (PLN 19065 - public hearing 5/15), I am asking for explanation as to how this project, or any other cell antenna application within close proximity to the Lake Merritt Wildlife Sanctuary, is exempt from CEQA. This Sanctuary is actually the first designated wildlife refuge in North America. Oakland Mayor Merritt declared it as wildlife refuge for migrating birds in 1869. In 1870, the state of California designated Lake Merritt a state game refuge. The lake serves as a home to hundreds of egrets, herons, ducks and geese, and a popular landing spot for many other migratory birds.

A number of species with the potential to occur at the project site are protected pursuant to federal and/or State endangered species laws. Section 15380(b) of the CEQA Guidelines provides a definition of rare, endangered or threatened species that are not included in any listing. Species recognized under these terms are collectively referred to as "special-status species." Special-status species include wildlife species listed as rare, threatened or endangered under the federal or State endangered species acts; species that are candidates for listing under either federal or State law; species formerly designated by the USFWS as Species of Concern or by CDFG as Species of Special Concern; species protected by the federal Migratory Bird Treaty Act (16 U.S Code [U.S.C.] 703-711); species such as candidate species that may be considered rare or endangered pursuant to Section 15380(b) of the CEQA Guidelines. In addition, Lake Merritt is one-half mile inland from the Oakland Estuary which is part of the Western Hemisphere Shorebird Reserve Network.

This is of concern as the U.S. Dept. of the Interior has documented the evidence linking effects of non-thermal, non-ionizing electromagnetic radiation from communication towers on nesting and roosting wild birds and other wildlife in the U.S. A peer-reviewed research protocol developed for the U.S. Forest Service by the Service's Division of Migratory Bird Management is available to study radiation impacts (Manville 2002). They cite a study showing strong negative correlations between levels of tower-emitted microwave radiation and bird breeding, nesting, and roosting in the vicinity of electromagnetic fields.
https://www.ntia.doc.gov/files/ntia/us_doi_comments.pdf

It would seem that before the Planning Commission decides upon whether to approve this cell antenna application, or any other near Lake Merritt, that they be given all the information regarding the wildlife protections in the area and how they relate to disturbances of migratory birds. Where is the comprehensive list of the special-status species that have been documented within the project area or have the potential to occur in the vicinity of the project site?

Pursuant to the requirements of the California Endangered Species Act (CESA), an agency reviewing a proposed project within its jurisdiction must determine whether any state-listed endangered or threatened species could be present on the project site and determine whether the proposed project could have a potentially significant impact on such species. Has the Planning Commission reviewed this?

Will the Commission be viewing this application in light of these Oakland General Plan Policies?

Policy CO-9.1: Protect rare, endangered, and threatened species by conserving and enhancing their habitat and requiring mitigation of potential adverse impacts when development occurs within habitat areas.

Policy CO-11.1: Protect wildlife from the hazards of urbanization, including loss of habitat and predation by domestic animals.

Policy CO-11.2: Protect and enhance migratory corridors for wildlife. Where such corridors are privately owned, require new development to retain native habitat or take other measures which help sustain local wildlife population and migratory patterns.

For instance, four special-status wildlife species may have potential for occurrence within the project site: Cooper's hawk, pallid bat, Townsend's big-eared bat, and hoary bat. Special-status birds may nest in the landscaped vegetation within the project site. Actively nesting birds (including birds, parts of birds, nests, and eggs) are protected under the Migratory Bird Treaty Act and CDFG Code Sections 3503 and 3503.5.

I am requesting that you place this email, and your reply, in the public records file for this project PLN 19065.

| | | |
|-----------|--------------------------------------|--|
| 2. | Location: | The Public Right of Way adjacent to 66 Lake Merritt Boulevard |
| | Assessor's Parcel Number(s): | 002-0091-001-00; The site is located northwest of the parcel at 66 Lake Merritt Blvd. |
| | Proposal: | Installation of a small cell wireless telecommunication facility on an existing 25' tall City Light Pole located in the public right-of-way. The project involves installation of one (1) antenna measuring 24.7" long and 10" in diameter within shroud at a height of 28'-6"; two (2) radio units (18" tall, 7.88" wide and 4.13" deep) and a meter box at a height of 10' and 11'-3" above ground. |
| | Applicant: | Vinculums Services for AT&T Wireless |
| | Contact Person/ Phone Number: | Justin Giarritta / (707) 225-2865 |
| | Owner: | City of Oakland |
| | Case File Number: | PLN19065 |
| | Planning Permits Required: | Major Conditional Use Permit and Major Design Review to install a Monopole Telecommunication Facility within 300 feet of a residential zone. |
| | General Plan: | Central Business District |
| | Zoning: | D-LM-4 Lake Merritt Station Area District Zone |
| | Environmental Determination: | Exempt, Section 15301 of the State CEQA Guidelines; minor additions and alterations to an PG&E utility pole; Section 15303: new construction or conversion of small structures; Section 15183: projects consistent with a community plan, general plan or zoning. |
| | Historic Status: | No Historic Record - Utility Pole |
| | City Council District: | 2 |
| | Finality of Decision: | Appealable to City Council within 10 days |
| | For Further Information: | Contact Case Planner Heather Klein at (510) 238-3659 or by email at hklein@oaklandca.gov. |

Thank you,
 Johanna Finney
 District 2

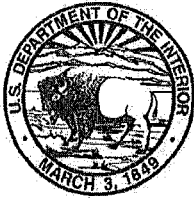

United States Department of the Interior

OFFICE OF THE SECRETARY
WASHINGTON, D.C. 20240

FEB - 7 2014



In Reply Refer To: (ER 14/0001) (ER 14/0004).

Mr. Eli Veenendaal
National Telecommunications and Information
Administration
U.S. Department of Commerce
1401 Constitution Avenue, N.W.
Washington, D.C. 20230

Dear Mr. Veenendaal:

The Department of the Interior (Department) has reviewed the above referenced proposal and submits the following comments and attachment for consideration. Because the First Responder Network Authority (FirstNet) is a newly created entity, we commend the U.S. Department of Commerce for its timely proposals for NEPA implementing procedures.

The Department believes that some of the proposed procedures are not consistent with Executive Order 13186 Responsibilities of Federal Agencies to Protect Migratory Birds, which specifically requires federal agencies to develop and use principles, standards, and practices that will lessen the amount of unintentional take reasonably attributed to agency actions. The Department, through the Fish and Wildlife Service (FWS), finds that the proposals lack provisions necessary to conserve migratory bird resources, including eagles. The proposals also do not reflect current information regarding the effects of communication towers to birds. Our comments are intended to further clarify specific issues and address provisions in the proposals.

The Department recommends revisions to the proposed procedures to better reflect the impacts to resources under our jurisdiction from communication towers. The placement and operation of communication towers, including un-guyed, unlit, monopole or lattice-designed structures, impact protected migratory birds in two significant ways. The first is by injury, crippling loss, and death from collisions with towers and their supporting guy-wire infrastructure, where present. The second significant issue associated with communication towers involves impacts from non-ionizing electromagnetic radiation emitted by them (See Attachment).

In addition to the 147 Birds of Conservation Concern (BCC) species, the FWS has listed an additional 92 species as endangered or threatened under the Endangered Species Act. Together with the bald and golden eagle, this represents 241 species of birds whose populations are in trouble or otherwise merit special protection, according to the varying criteria of these lists. The Department suggests that FirstNet consider preparing a programmatic environmental impact statement (see attachment) to determine and address cumulative impacts from authorizing FirstNet projects on those 241 species for which the incremental impact of tower mortality, when

added to other past, present, and reasonably foreseeable future actions, is most likely significant, given their overall imperiled status. Notwithstanding the proposed implementing procedures, a programmatic NEPA document might be the most effective and efficient method for establishing best management practices for individual projects, reducing the burden to individual applicants, and addressing cumulative impacts.

Categorical Exclusions

The Department has identified 13 of the proposed categorical exclusions (A-6, A-7, A-8, A-9, A-10, A-11, A-12, A-13, A-14 A-15, A-16, A-17, and A-19) as having the potential to significantly affect wildlife and the biological environment. Given this potential, we want to underscore the importance of our comments on FirstNet's procedural guidance under Environmental Review and Consultation Requirements for NEPA Reviews and its list of extraordinary circumstances in Appendix D.

Environmental Review and Consultation Requirements for NEPA Reviews

To ensure there are no potentially significant impacts on birds from projects that may otherwise be categorically excluded, the Department recommends including the Migratory Bird Treaty Act and the Bald and Golden Eagle Protection Act to the list of requirements in this section.

Extraordinary Circumstances

To avoid potentially significant impacts on birds from projects that may otherwise be categorically excluded, the Department recommends including species covered under the Migratory Bird Treaty Act and the Bald and Golden Eagle Protection Act to the list of environmentally sensitive resources. Additionally, adding important resources to migratory birds such as sites in the Western Hemisphere Shorebird Reserve Network and Audubon Important Bird Areas to the paragraph on areas having special designation or recognition would help ensure their consideration when contemplating use of a categorical exclusion.

Developing the Purpose and Need

The Department recommends inclusion of language that would ensure consideration of all other authorities to which NEPA is supplemental as opposed to simply the FirstNet mission. As currently written, the procedures are limited to ensuring the purpose and need considers the FirstNet mission. If strictly applied, this approach would severely limit the range of reasonable alternatives, and likely preclude consideration of more environmentally benign locations or construction practices.

Environmental Review Process, Apply NEPA Early in the Process, Where Action is by Non-Federal Entity

The Department recommends that FirstNet be required to coordinate with federal agencies having jurisdiction by law or special expertise on construction and lighting of its network of towers.

Thank you for the opportunity to comment on the draft document. If you have any questions concerning the comments, please contact Diana Whittington, NEPA Migratory Bird lead, at (703) 358-2010. If you have any questions regarding Departmental NEPA procedures, contact Lisa Treichel, Office of Environmental Policy and Compliance at (202) 208-7116.

Sincerely,

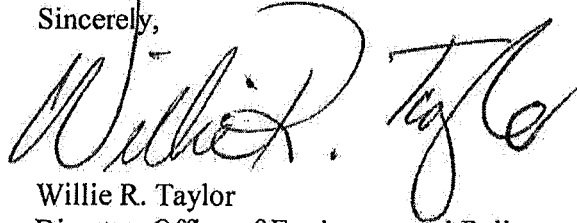
A handwritten signature in black ink, appearing to read "Willie R. Taylor". The signature is written in a cursive style with a large, prominent initial "W".

Willie R. Taylor
Director, Office of Environmental Policy
and Compliance

Enclosure

Literature Cited

- Longcore, T., C. Rich, P. Mineau, B. MacDonald, D.G. Bert, L.M. Sullivan, E. Mutrie, S.A. Gauthreaux, Jr., M.L. Avery, R.C. Crawford, A.M. Manville, II, E.R. Travis, and D. Drake. 2013. Avian mortality at communication towers in the United States and Canada: which species, how many, and where? *Biological Conservation* 158: 410-419.
- U.S. Fish and Wildlife Service. 2008. Birds of Conservation Concern, 2008. United States Department of Interior, Fish and Wildlife Service, Division of Migratory Bird Management, Arlington, VA. 85 pages. <http://www.fws.gov/migratorybirds>.

Enclosure A

Background

The placement and operation of communication towers, including un-guyed, unlit, monopole or lattice-designed structures, impact protected migratory birds in two significant ways.

The first is by injury, crippling loss, and death from collisions with towers and their supporting guy-wire infrastructure, where present. Mass mortality events tend to occur during periods of peak spring and fall songbird migration when inclement weather events coincide with migration, and frequently where lights (either on the towers and/or on adjacent outbuildings) are also present. This situation has been well documented in the U.S. since 1948 in the published literature (Aronoff 1949, see Manville 2007a for a critique). The tallest communication towers tend to be the most problematic (Gehring *et al.* 2011). However, mid-range (~400-ft) towers as proposed by the First Responder Network Authority (FirstNet, a newly created entity under the Department of Commerce) can also significantly impact protected migratory birds, as can un-guyed and unlit lattice and monopole towers (Gehring *et al.* 2009, Manville 2007a, 2009, 2013a). Mass mortalities (more than several hundred birds per night) at un-guyed, unlit monopole and lattice towers were documented in fall 2005 and 2011 in the Northeast and North Central U.S. (*e.g.*, Manville 2007a). It has been argued that communication towers including "short" towers do not impact migratory birds, including at the population level (*e.g.*, Arnold and Zink 2011), but recent findings have contradicted that assertion (Manville 2007a, 2013a, Longcore *et al.* 2012, 2013).

The second significant issue associated with communication towers involves impacts from non-ionizing electromagnetic radiation emitted by these structures. Radiation studies at cellular communication towers were begun circa 2000 in Europe and continue today on wild nesting birds. Study results have documented nest and site abandonment, plumage deterioration, locomotion problems, reduced survivorship, and death (*e.g.*, Balmori 2005, Balmori and Hallberg 2007, and Everaert and Bauwens 2007). Nesting migratory birds and their offspring have apparently been affected by the radiation from cellular phone towers in the 900 and 1800 MHz frequency ranges – 915 MHz is the standard cellular phone frequency used in the United States. However, the electromagnetic radiation standards used by the Federal Communications Commission (FCC) continue to be based on thermal heating, a criterion now nearly 30 years out of date and inapplicable today. This is primarily due to the lower levels of radiation output from microwave-powered communication devices such as cellular telephones and other sources of point-to-point communications; levels typically lower than from microwave ovens. The problem, however, appears to focus on very low levels of non-ionizing electromagnetic radiation. For example, in laboratory studies, T. Litovitz (personal communication) and DiCarlo *et al.* (2002) raised concerns about impacts of low-level, non-thermal electromagnetic radiation from the standard 915 MHz cell phone frequency on domestic chicken embryos – with some lethal results (Manville 2009, 2013a). Radiation at extremely low levels (0.0001 the level emitted by the average digital cellular telephone) caused heart attacks and the deaths of some chicken embryos subjected to hypoxic conditions in the laboratory while controls subjected to hypoxia were unaffected (DiCarlo *et al.* 2002). To date, no independent, third-party field studies have been conducted in North America on impacts of tower electromagnetic radiation on migratory birds. With the European field and U.S. laboratory evidence already available,

independent, third-party peer-reviewed studies need to be conducted in the U.S. to begin examining the effects from radiation on migratory birds and other trust species.

Discussion

Collision Deaths and Categorical Exclusions

Attempts to estimate bird-collision mortality at communication towers in the U.S. resulted in figures of 4-5 million bird deaths per year (Manville 2005, 2009). A meta-review of the published literature now suggests, based on statistically determined parameters, that mortality may be 6.8 million birds per year in Canada and the U.S.; the vast majority in the United States (Longcore *et al.* 2012). Up to 350 species of birds have been killed at communication towers (Manville 2007a, 2009). The Service's Division of Migratory Bird Management has updated its voluntary, 2000 communication tower guidelines to reflect some of the more recent research findings (Manville 2013b). However, the level of estimated mortality alone suggests at a minimum that FirstNet prepare an environmental assessment to estimate and assess the cumulative effects of tower mortality to protected migratory birds.

A second meta-review of the published mortality data from scientific studies conducted in the U.S. and Canada (Longcore *et al.* 2013) strongly correlates population effects to at least 13 species of Birds of Conservation Concern (BCC, USFWS 2008). These are mortalities to BCC species based solely on documented collisions with communication towers in the U.S. and Canada, ranging from estimated annual levels of mortality of 1 to 9% of their estimated total population. Among these where mortality at communication towers was estimated at over 2% annually are the Yellow Rail, Swainson's Warbler, Pied-billed Grebe, Bay-breasted Warbler, Golden-winged Warbler, Prairie Warbler, and Ovenbird. Longcore *et al.* (2013) emphasized that avian mortality associated with anthropogenic sources is almost always reported in the aggregate, *i.e.*, "number of birds killed," which cannot detect species-level effects necessary to make effective and meaningful conservation assessments, including determining cumulative effects. These new findings strongly suggest the need for at least an environmental assessment by FirstNet, or more likely, an environmental impact statement.

Radiation Impacts and Categorical Exclusions

There is a growing level of anecdotal evidence linking effects of non-thermal, non-ionizing electromagnetic radiation from communication towers on nesting and roosting wild birds and other wildlife in the U.S. Independent, third-party studies have yet to be conducted in the U.S. or Canada, although a peer-reviewed research protocol developed for the U.S. Forest Service by the Service's Division of Migratory Bird Management is available to study both collision and radiation impacts (Manville 2002).

As previously mentioned, Balmori (2005) found strong negative correlations between levels of tower-emitted microwave radiation and bird breeding, nesting, and roosting in the vicinity of electromagnetic fields in Spain. He documented nest and site abandonment, plumage deterioration, locomotion problems, reduced survivorship, and death in House Sparrows, White Storks, Rock Doves, Magpies, Collared Doves, and other species. Though these species had historically been documented to roost and nest in these areas, Balmori (2005) did not observe these symptoms prior to construction and operation of the cellular phone towers. Balmori and Hallberg (2007) and Everaert and Bauwens (2007) found similar strong negative correlations

among male House Sparrows. Under laboratory conditions, DiCarlo *et al.* (2002) raised troubling concerns about impacts of low-level, non-thermal electromagnetic radiation from the standard 915 MHz cell phone frequency on domestic chicken embryos – with some lethal results (Manville 2009). Given the findings of the studies mentioned above, field studies should be conducted in North America to validate potential impacts of communication tower radiation – both direct and indirect – to migratory birds and other trust wildlife species.

Literature Cited

- Arnold, T. W., and R.M. Zink. 2011. Collision mortality has no discernable effect on population trends of North American birds. *Plos ONE* 6:e24708.
- Aronoff, A. 1949. The September migration tragedy. *Linnaean News-Letter* 3(1):2.
- Balmori, A. 2005. Possible effects of electromagnetic fields from phone masts on a population of White Stork (*Ciconia ciconia*). *Electromagnetic Biology and Medicine* 24:109-119.
- Balmori, A., and O. Hallberg. 2007. The urban decline of the House Sparrow (*Passer domesticus*): a possible link with electromagnetic radiation. *Electromagnetic Biology and Medicine* 26:141-151.
- DiCarlo, A., N. White, F. Guo, P. Garrett, and T. Litovitz. 2002. Chronic electromagnetic field exposure decreases HSP70 levels and lowers cytoprotection. *Journal Cellular Biochemistry* 84: 447-454.
- Everaert, J., and D. Bauwens. 2007. A possible effect of electromagnetic radiation from mobile phone base stations on the number of breeding House Sparrows (*Passer domesticus*). *Electromagnetic Biology and Medicine* 26:63-72.
- Gehring, J., P. Kerlinger, and A.M. Manville, II. 2009. Communication towers, lights, and birds: successful methods of reducing the frequency of avian collisions. *Ecological Applications* 19:505-514.
- Gehring, J., P. Kerlinger, and A.M. Manville, II. 2011. The role of tower height and guy wires on avian collisions with communication towers. *Journal of Wildlife Management* 75: 848-855.
- Longcore, T., C. Rich, P. Mineau, B. MacDonald, D.G. Bert, L.M. Sullivan, E. Mutrie, S.A. Gauthreaux, Jr., M.L. Avery, R.C. Crawford, A.M. Manville, II, E.R. Travis, and D. Drake. 2012. An estimate of avian mortality at communication towers in the United States and Canada. *PLoS ONE* 7(4) 17 pp, Open Access.
- Longcore, T., C. Rich, P. Mineau, B. MacDonald, D.G. Bert, L.M. Sullivan, E. Mutrie, S.A. Gauthreaux, Jr., M.L. Avery, R.C. Crawford, A.M. Manville, II, E.R. Travis, and D. Drake. 2013. Avian mortality at communication towers in the United States and Canada: which species, how many, and where? *Biological Conservation* 158: 410-419.
- Manville, A.M., II. 2002. Protocol for monitoring the impacts of cellular telecommunication towers on migratory birds within the Coconino, Prescott, and Kaibab National Forests, Arizona. Peer-reviewed research monitoring protocol requested by and prepared for the U.S. Forest Service. Division of Migratory Bird Management, USFWS. 9 pp, March 2002.
- Manville, A.M., II. 2005. Bird strikes and electrocutions at power lines, communication towers, and wind turbines: state of the art and state of the science – next steps toward mitigation. Pages 1051-1064 *In* C.J. Ralph and T.D. Rich (eds), *Bird Conservation Implementation in the Americas: Proceedings 3rd International Partners in Flight Conference*, U.S.D.A. Forest Service Gen. Technical Report PSW-GTR-191, Albany, CA.
- Manville, A.M., II. 2007a. Comments of the U.S. Fish and Wildlife Service submitted electronically to the FCC on 47 CFR Parts 1 and 17, WT Docket No. 03-187, FCC 06-164, Notice of Proposed Rulemaking, “Effects of Communication Towers on Migratory Birds.” February 2, 2007. 32 pp.
- Manville, A.M., II. 2007b. U.S. Fish and Wildlife concerns over potential radiation impacts from cellular communication towers on migratory birds and other wildlife – research opportunities. Invited Presentation to “Congressional Staff Briefing on the Environmental and Human Health Effects of Radiofrequency (RF) Radiation,” House Capitol 5, Washington, DC. 16 page PowerPoint presentation. May 10, 2007.

- Manville, A.M. II. 2009. Towers, turbines, power lines and buildings – steps being taken by the U.S. Fish and Wildlife Service to avoid or minimize take of migratory birds at these structures. Pages 262-272 in T.D. Rich, C. Arizmendi, D.W. Demarest, and C. Thompson (eds.). *Tundra to Tropics: Connecting Birds, Habitats and People*. Proceedings 4th International Partners in Flight Conference, McAllen, Texas.
- Manville, A.M., II. 2011. Estimates of annual human-caused mortality to North American birds (with literature citations). Division of Migratory Bird Management, USFWS, for public distribution. 12 pages.
- Manville, A.M., II. 2013a. Anthropogenic-related bird mortality focusing on steps to address human-caused problems. A White Paper for the Anthropogenic Panel, 5th International Partners in Flight Conference, Snowbird, Utah. August 27, 2013. 16 page peer-reviewed White Paper.
- Manville, A.M., II. 2013b. U.S. Fish and Wildlife Service (USFWS) revised guidelines for communication tower design, siting, construction, operation, retrofitting, and decommissioning -- Suggestions based on previous USFWS recommendations to FCC regarding WT Docket No. 03-187, FCC 06-164, Notice of Proposed Rulemaking, "Effects of Communication Towers on Migratory Birds," Docket No. 08-61, FCC's Antenna Structure Registration Program, and Service 2012 Wind Energy Guidelines. Division of Migratory Bird Management, Arlington, VA. 5 pages.
- U.S. Fish and Wildlife Service. 2008. *Birds of Conservation Concern, 2008*. United States Department of Interior, Fish and Wildlife Service, Division of Migratory Bird Management, Arlington, VA. 85 pages. <http://www.fws.gov/migratorybirds>.