

# Oakland City Planning Commission

Case nos. PLN17510 / PLN18029

STAFF REPORT

November 28, 2018

<b>Locations:</b>	City street light pole in public right-of-way adjacent to:  <b>1) Case no. PLN17510; 2215 Champion St / 3438 Fruitvale Ave</b> (APN: 028 -0905-01-02); Submitted: 12/28/17; General Plan: Neighborhood Center Mixed Use; Zoning: CN-1 Neighborhood Commercial; <u>Council District: 4</u>  <b>2) Case no. PLN18029; 3624 Champion St</b> (APN: 028 -0907-017-02); Submitted: 1/12/18; General Plan: Mixed Housing Type Residential; Zoning: RM-3
<b>Proposal:</b>	To consider requests for two (2) applications to install a new "small cell site" Monopole Telecommunications Facility on a City light pole by attaching antenna and equipment.
<b>Applicant / Phone Number:</b>	James Singleton for Mobilitie / (650) 814-0564
<b>Owner:</b>	City of Oakland
<b>Planning Permits Required:</b>	Major Conditional Use Permit and Regular Design Review with additional findings for Monopole Telecommunications Facility in or near a Residential Zone; Minor Variance for proximity to a residential property (Site # 2)
<b>Environmental Determination:</b>	Exempt, Section 15301 of the State CEQA Guidelines: Existing Facilities; Exempt, Section 15302: Replacement or Reconstruction; Exempt, Section 15303: New Construction of Small Structures; Section 15183: Projects Consistent with a Community Plan, General Plan or Zoning
<b>Historic Status:</b>	Non-historic properties
<b>Action to be Taken:</b>	Approve with Conditions
<b>Finality of Decision:</b>	<i>Appealable to City Council within 10 days</i>
<b>For Further Information:</b>	Contact case planner <b>Aubrey Rose AICP</b> at (510) 238-2071 or <a href="mailto:arose@oaklandca.gov">arose@oaklandca.gov</a>

## EXECUTIVE SUMMARY

The applicant requests Planning Commission approval of two (2) applications to establish a "small cell site" Monopole Telecommunications Facility on an existing City street light pole located in the public right-of-way in residential and commercial districts. The project involves attaching one antenna within a shroud to the top of the pole and equipment mounted to the side of the pole, as described in the submitted plans, to enhance wireless service in the area.

Regular Design Review and a Major Conditional Use Permit decided by the Planning Commission, each with additional findings, are required for the installation of a new Monopole Telecommunications Facility in or near a Residential Zone. The proposed projects, antenna and associated equipment, would be similar to other facilities around the City. The proposed telecommunications facility is therefore sited at an appropriate location and would not significantly increase negative visual impacts to adjacent properties including residences. The applications meet all the required findings for approval of these two (2) small cell sites.

# CITY OF OAKLAND PLANNING COMMISSION

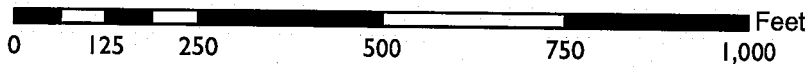
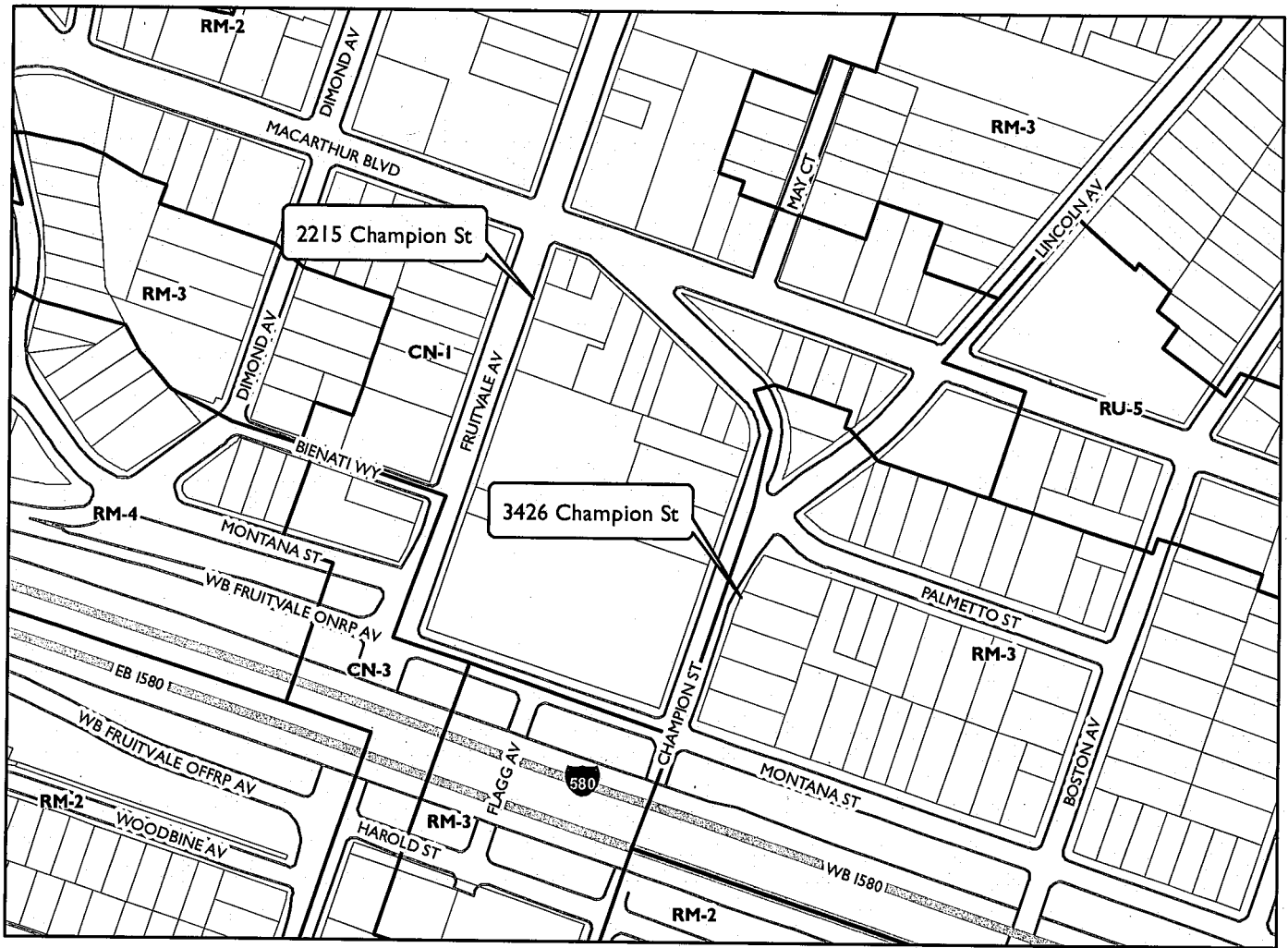

Case Files: PLN17510, PLN18029  
Applicant: James Singleton for Mobilitie  
Addresses: City street light pole in public right-of-way adjacent to  
a) 2215 Champion St, b) 3426 Champion St  
Zones: CN-1, RM-3

## **TELECOMMUNICATIONS BACKGROUND**

### **Limitations on Local Government Zoning Authority under the Telecommunications Act of 1996**

Section 704 of the Telecommunications Act of 1996 (TCA) provides federal standards for the siting of "Personal Wireless Services Facilities." "Personal Wireless Services" include all commercial mobile services (including personal communications services (PCS), cellular radio mobile services, and paging); unlicensed wireless services; and common carrier wireless exchange access services. Under Section 704, local zoning authority over personal wireless services is preserved such that the FCC is prevented from preempting local land use decisions; however, local government zoning decisions are still restricted by several provisions of federal law. Specifically:

- Under Section 253 of the TCA, no state or local regulation or other legal requirement can prohibit or have the effect of prohibiting the ability of any entity to provide any interstate or intrastate telecommunications service.
- Further, Section 704 of the TCA imposes limitations on what local and state governments can do. Section 704 prohibits any state and local government action which unreasonably discriminates among personal wireless providers. Local governments must ensure that its wireless ordinance does not contain requirements in the form of regulatory terms or fees which may have the "effect" of prohibiting the placement, construction, or modification of personal wireless services.
- Section 704 also preempts any local zoning regulation purporting to regulate the placement, construction and modification of personal wireless service facilities on the basis, either directly or indirectly, on the environmental effects of radio frequency emissions (RF) of such facilities, which otherwise comply with Federal Communications Commission (FCC) standards in this regard. (See 47 U.S.C. Section 332(c)(7)(B)(iv) (1996)). This means that local authorities may not regulate the siting or construction of personal wireless facilities based on RF standards that are more stringent than those promulgated by the FCC.
- Section 704 mandates that local governments act upon personal wireless service facility siting applications to place, construct, or modify a facility within a reasonable time (See 47 U.S.C.332(c)(7)(B)(ii) and FCC Shot Clock ruling setting forth "reasonable time" standards for applications deemed complete).
- Section 704 also mandates that the FCC provide technical support to local governments in order to encourage them to make property, rights-of-way, and easements under their jurisdiction available for the placement of new spectrum-based telecommunications services. This proceeding is currently at the comment stage.

For more information on the FCC's jurisdiction in this area, consult the following:

Competition & Infrastructure Policy Division (CIPD) of the Wireless Telecommunications Bureau, main division number: (202) 418-1310. <https://www.fcc.gov/general/competition-infrastructure-policy-division-wireless-telecommunications-bureau>

## **PROPERTY DESCRIPTION**

City street light poles, measuring 26 to 28'-8" in height, located in the public right-of-way (sidewalk towards curb) adjacent to:

**1) Case no. PLN17510; 2215 Champion Street along Fruitvale Avenue:** adjacent a one-story commercial building housing a bank business at a commercial node with MacArthur Boulevard.

2) **Case no. PLN18029; 3426 Champion Street near Palmetto Street:** adjacent a two-story single family home with upper story windows and across the street from the rear of a drug store with no windows. The site is located to the south of the Dimond District and is situated between the 580 freeway and MacArthur Boulevard.

### **PROJECT DESCRIPTION**

All sites are proposed for:

- Installation by top-mounting one omni-directional antenna within a 4'-6" shroud above the street light to extend to 30'-6" or 33'-2" in height;
- Installation of side-mounted 3' equipment below the street light centered at 18'-3" or 20'-6" in height; and,
- Paint and texturize the proposed and antennas and associated equipment to match the pole.

No portion of the telecommunication facilities would be located at grade. The proposed antenna and associated equipment would not be accessible to the public.

### **SIMILAR CASES**

Records show that the Planning Commission has approved numerous Monopole Telecommunications Facilities requiring Design Review and Conditional Use Permits throughout the City since 2016.

### **GENERAL PLAN ANALYSIS**

Site # 1 is located in the Neighborhood Center Mixed Use area of the General Plan's Land Use and Transportation Element (LUTE). The intent of the area is: "to identify, create, maintain and enhance mixed use neighborhood commercial centers. These centers are typically characterized by smaller scale pedestrian-oriented, continuous street frontage with a mix of retail, housing, office, active open space, eating and drinking places, personal and business services, and smaller scale educational, cultural, or entertainment uses." Site # 2 is in the Mixed Housing Type Residential area; the intent of the area is: "to create, maintain, and enhance residential areas typically located near the City's major arterials and characterized by a mix of single family homes, townhouses, small multi-unit buildings, and neighborhood businesses where appropriate." The proposed telecommunication facilities would be mounted on existing City street light poles within the City of Oakland public right-of-way. The proposed unmanned wireless telecommunication facility would not adversely affect the characteristics of the neighborhood.

## ZONING ANALYSIS

Site # 1 is located in the CN-1 Neighborhood Commercial Zone. Site # 2 is in the RM-3 Mixed Housing Type Residential Zone. Monopole Telecommunications Facilities on City light poles require a Conditional Use Permit and a Regular Design Review with additional findings; these permits are decided by the Planning Commission for sites located in or near to a residential zone. New wireless telecommunications facilities may also be subject to a Site Alternatives Analysis, Site Design Alternatives Analysis, and a satisfactory radio-frequency (RF) emissions report. Staff analyzes the proposal in consideration of these requirements in the 'Key Issues and Impacts' section of this report. Additionally, attachment to City infrastructure requires review by the City's Real Estate Department, Public Works Agency's Electrical Division, and Information Technology Department. Given customers increasing reliance upon cellular service for phone and Wi-Fi, the proposal for a Monopole Telecommunications Facility that is not adjacent to a primary living space or historic structure conforms to this intent.

## ENVIRONMENTAL DETERMINATION

The California Environmental Quality Act (CEQA) Guidelines list the projects that qualify as categorical exemptions from environmental review. The proposed project is categorically exempt from the environmental review requirements pursuant to Section 15301, minor additions and alterations to an existing City street light pole; Section 15302, replacement or reconstruction of existing utility systems and/or facilities; Section 15303, new construction or conversion of small structures, and Section 15183, projects consistent with the General Plan or Zoning.

## KEY ISSUES AND IMPACTS

The proposal to establish a Monopole Telecommunications Facility is subject to the following Planning Code development standards, which are followed by staff's analysis in relation to this application:

### **17.128.080 Monopole Telecommunications Facilities.**

#### **A. General Development Standards for Monopole Telecommunications Facilities.**

**1. Applicant and owner shall allow other future wireless communications companies including public and quasi-public agencies using similar technology to collocate antenna equipment and facilities on the monopole unless specific technical or other constraints, subject to independent verification, at the applicant's expense, at the discretion of the City of Oakland Zoning Manager, prohibit said collocation. Applicant and other wireless carriers shall provide a mechanism for the construction and maintenance of shared facilities and infrastructure and shall provide for equitable sharing of cost in accordance with industry standards. Construction of future facilities shall not interrupt or interfere with the continuous operation of applicant's facilities.**

The proposal involves use of an existing City of Oakland metal street light pole that would remain available for future collocation purposes as practicable.

**2. The equipment shelter or cabinet must be concealed from public view or made compatible with the architecture of the surrounding structures or placed underground. The shelter or cabinet must be regularly maintained.**

Recommended conditions of approval require painting and texturing the antenna and equipment to match the appearance of the metal pole. There is no equipment shelter or cabinet proposed; however, minimal equipment would be closely mounted onto the side of the metal pole.

**3. When a monopole is in a Residential Zone or adjacent to a residential use, it must be set back from the nearest residential lot line a distance at least equal to its total height.**

Site # 2 fronts a single-family home property and this finding is not met by the proposal; a Variance is therefore required. Findings to support the Variance can be made by this proposal, as described in Attachment A.

**4. In all zones other than the D-CE-5, D-CE-6, IG, CIX-2, and IO Zones, the maximum height of Monopole Telecommunications Facilities and connecting appurtenances may be increased from the otherwise required maximum height to forty-five (45) feet upon the granting of a Conditional Use Permit (see Chapter 17.134 for the Conditional Use Permit Procedure).**

This requirement does not apply. The subject property is not located in any of the described zoning districts. Nonetheless, the facility would not exceed the height of 33'-2".

**5. In the D-CE-5, D-CE-6, CIX-2, and IO Zones, the maximum height of Monopole Telecommunications Facilities and connecting appurtenances may be increased from the otherwise required maximum height to eighty (80) feet upon the granting of a Conditional Use Permit (see Chapter 17.134 for the Conditional Use Permit Procedure).**

This requirement does not apply. The subject property is not located in any of the described zoning districts. Nonetheless, the facility would not exceed the height of 33'-2".

**6. In the IG Zone, the maximum height of Monopole Telecommunications Facilities and connecting appurtenances may reach a height of forty-five (45) feet. These facilities may reach a height of eighty (80) feet upon the granting of Regular Design Review approval (see Chapter 17.136 for the Design Review Procedure).**

This requirement does not apply. The subject property is not located in the described zoning district. Nonetheless, the facility would not exceed the height of 33'-2".

**7. The applicant shall submit written documentation demonstrating that the emissions from the proposed project are within the limits set by the Federal Communications Commission.**

This standard is met by the proposal; a satisfactory emissions report has been submitted and is attached to this report (Attachments C-D).

**8. Antennas may not extend more than fifteen (15) feet above their supporting structure.**

The proposed antenna would project less than fifteen feet above the City light pole.

**17.128.110 Site location preferences.**

New wireless facilities shall generally be located on the following properties or facilities in order of preference:

- A. Co-located on an existing structure or facility with existing wireless antennas.
- B. City-owned properties or other public or quasi-public facilities.
- C. Existing commercial or industrial structures in Nonresidential Zones (excluding all HBX Zones and the D-CE-3 and D-CE-4 Zones).
- D. Existing commercial or industrial structures in Residential Zones, HBX Zones, or the DCE-3 or D-CE-4 Zones.
- E. Other Nonresidential uses in Residential Zones, HBX Zones, or the D-CE-3 or D-CE-4 Zones.

**F. Residential uses in Nonresidential Zones (excluding all HBX Zones and the D-CE-3 and D-CE-4 Zones).**

**G. Residential uses in Residential Zones, HBX Zones, or the D-CE-3 or D-CE-4 Zones.**

Facilities locating on an A, B or C ranked preference do not require a site alternatives analysis. Facilities proposing to locate on a D through G ranked preference, inclusive, must submit a site alternatives analysis as part of the required application materials. A site alternatives analysis shall, at a minimum, consist of: a. The identification of all A, B and C ranked preference sites within one thousand (1,000) feet of the proposed location. If more than three (3) sites in each preference order exist, the three such closest to the proposed location shall be required. b. Written evidence indicating why each such identified alternative cannot be used. Such evidence shall be in sufficient detail that independent verification, at the applicant's expense, could be obtained if required by the City of Oakland Zoning Manager. Evidence should indicate if the reason an alternative was rejected was technical (e.g. incorrect height, interference from existing RF sources, inability to cover required area) or for other concerns (e.g. refusal to lease, inability to provide utilities).

A site alternatives analysis is not required because the proposal conforms to 'B' as it would be located on a public facility (City street light pole). Nonetheless, the applicant has submitted an analysis which is attached to this report (Attachments C-D).

**17.128.120 Site design preferences.**

New wireless facilities shall generally be designed in the following order of preference:

- A. Building or structure mounted antennas completely concealed from view.**
- B. Building or structure mounted antennas set back from roof edge, not visible from public right-of-way.**
- C. Building or structure mounted antennas below roof line (facade mount, pole mount) visible from public right-of-way, painted to match existing structure.**
- D. Building or structure mounted antennas above roof line visible from public right-of-way.**
- E. Monopoles.**
- F. Towers.**

Facilities designed to meet an A or B ranked preference do not require a site design alternatives analysis. Facilities designed to meet a C through F ranked preference, inclusive, must submit a site design alternatives analysis as part of the required application materials. A site design alternatives analysis shall, at a minimum, consist of: a. Written evidence indicating why each such higher preference design alternative cannot be used. Such evidence shall be in sufficient detail that independent verification could be obtained if required by the City of Oakland Zoning Manager. Evidence should indicate if the reason an alternative was rejected was technical (e.g. incorrect height, interference from existing RF sources, inability to cover required area) or for other concerns (e.g. inability to provide utilities, construction or structural impediments).

The proposal most closely conforms to 'E' (monopole) and the applicant has submitted a satisfactory site design alternatives analysis (Attachments C-D).

**17.128.130 Radio frequency emissions standards.**

The applicant for all wireless facilities, including requests for modifications to existing facilities, shall submit the following verifications:

- a. With the initial application, a RF emissions report, prepared by a licensed professional engineer or other expert, indicating that the proposed site will operate within the current acceptable thresholds as established by the Federal government or any such agency who may be subsequently authorized to establish such standards.**
- b. Prior to commencement of construction, a RF emissions report indicating the baseline RF emissions condition at the proposed site.**

c. Prior to final building permit sign off, an RF emissions report indicating that the site is actually operating within the acceptable thresholds as established by the Federal government or any such agency who may be subsequently authorized to establish such standards.

A satisfactory report is attached to this report (Attachments C-D).

Analysis

The proposed site design would not be situated on an historic or decorative pole or structure, would not create a view obstruction, and would not negatively impact a view from a primary living space such as a living room or bedroom window. For Site # 2, the proximity to a residential property line is justified as the top of the pole is higher than and not in line with the upper story bed rooms windows at the adjacent home; the project should not therefore obstruct views or be excessively close to the windows. Staff, therefore, finds the proposal to provide an essential service with a least-intrusive possible design. Draft conditions of approval stipulate that the components be painted and textured to match the metal pole in appearance for camouflaging.

In conclusion, staff recommends approval subject to recommended Conditions of Approval.

**RECOMMENDATIONS:**

1. Affirm staff's environmental determination.
2. Approve the Major Conditional Use Permit, Regular Design Review and Minor Variance (Site # 2) subject to the attached Findings and Conditions of Approval.

Prepared by:

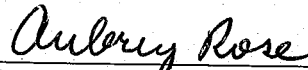

AUBREY ROSE, AICP  
Planner III

Reviewed by:

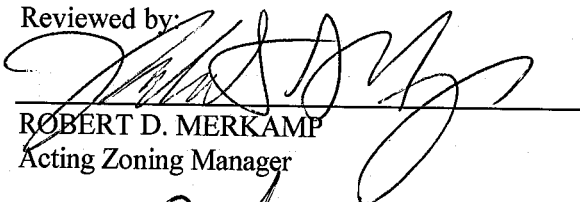

ROBERT D. MERKAMP  
Acting Zoning Manager

Approved for forwarding to the Planning Commission:

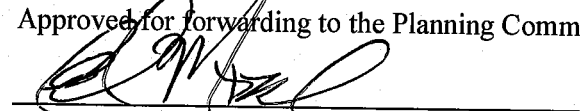

ED MANASSE, Interim Deputy Director  
Planning Bureau

**ATTACHMENTS:**

- A. Findings
- B. Conditions of Approval

Plans / Photo-Simulations / Site Analyses / RF Report:

- C. Site # 1: Case no. PLN17510; 2215 Champion Street
- D. Site # 2: Case no. PLN18029; 3426 Champion Street



**ATTACHMENT A: FINDINGS**

This proposal meets the required findings under General Use Permit Criteria (OMC Sec. 17.134.050), Conditional Use Permit Criteria for Monopole Facilities (OMC Sec. 17.136.040 (A)), Regular Design Review Criteria for Nonresidential Facilities (OMC Sec. 17.136.050(B)), Design Review Criteria for Monopole Telecommunications Facilities (OMC Sec. 17.128.070(B)), and Variance Procedure/Findings Required (OMC Sec. 17.148.050), as set forth below. Required findings are shown in **bold type**; explanations as to why these findings can be made are in normal type.

**GENERAL USE PERMIT CRITERIA (OMC SEC. 17.134.050):**

**A. That the location, size, design, and operating characteristics of the proposed development will be compatible with and will not adversely affect the livability or appropriate development of abutting properties and the surrounding neighborhood, with consideration to be given to harmony in scale, bulk, coverage, and density; to the availability of civic facilities and utilities; to harmful effect, if any, upon desirable neighborhood character; to the generation of traffic and the capacity of surrounding streets; and to any other relevant impact of the development.**

The proposal is to establish a Monopole Telecommunications Facility in or near a residential zone by attaching to an existing City light pole. Attachment to an existing structure with smallest possible components painted and texturized to match the pole will be the least intrusive design. The project will enhance existing service for merchants, shoppers, residents, and visitors in the area.

**B. That the location, design, and site planning of the proposed development will provide a convenient and functional living, working, shopping, or civic environment, and will be as attractive as the nature of the use and its location and setting warrant.**

Attachment to an existing structure with smallest possible components painted and texturized to match the pole will be the least intrusive design.

**C. That the proposed development will enhance the successful operation of the surrounding area in its basic community functions, or will provide an essential service to the community or region.**

The project will enhance existing service for merchants, shoppers, residents, and visitors in the area.

**D. That the proposal conforms to all applicable design review criteria set forth in the design review procedure at Section 17.136.070.**

The proposal conforms to Design Review findings which are included in that section of this attachment of Findings for Approval.

**E. That the proposal conforms in all significant respects with the Oakland Comprehensive Plan and with any other applicable plan or development control map which has been adopted by the City Council.**

Site # 1 is located in the Neighborhood Center Mixed Use area of the General Plan's Land Use and Transportation Element (LUTE). The intent of the area is: "to identify, create, maintain and enhance mixed use neighborhood commercial centers. These centers are typically characterized by smaller scale pedestrian-oriented, continuous street frontage with a mix of retail, housing, office, active open space, eating and drinking places, personal and business services, and smaller scale educational, cultural, or entertainment uses." Site # 2 is in the Mixed Housing Type Residential area; the intent of the area is: "to create, maintain, and enhance residential areas typically located near the City's major arterials and characterized by a mix of single family homes, townhouses, small multi-unit buildings, and neighborhood businesses where appropriate." The proposed telecommunication facilities would be mounted on existing City street light poles within the City of Oakland public right-of-way. The proposed unmanned wireless telecommunications facility would not adversely affect the characteristics of the neighborhood.

**CONDITIONAL USE PERMIT CRITERIA FOR MONOPOLE FACILITIES (OMC  
SEC. 17.128.070(C))**

**1. The project must meet the special design review criteria listed in subsection B of this section.**

The proposal conforms to Design Review findings which are included in that section of this attachment of Findings for Approval.

**2. Monopoles should not be located any closer than one thousand five hundred (1,500) feet from existing monopoles unless technologically required or visually preferable.**

Use of this pole precludes placement of a new pole with facility fronting an upper story residences at various viable sites in the surrounding area and is therefore "visually preferable."

**3. The proposed project must not disrupt the overall community character.**

Attachment to an existing structure with smallest possible components painted and texturized to match the pole will be the least intrusive design. The project will enhance existing service for merchants, shoppers, residents, and visitors in the area.

**4. If a major conditional use permit is required, the Planning Director or the Planning Commission may request independent expert review regarding site location, collocation and facility configuration. Any party may request that the Planning Commission consider making such request for independent expert review.**

**a. If there is any objection to the appointment of an independent expert engineer, the applicant must notify the Planning Director within ten (10) days of the Commission request. The Commission will hear arguments regarding the need for the independent expert and the applicant's objection to having one appointed. The Commission will rule as to whether an independent expert should be appointed.**

**b. Should the Commission appoint an independent expert, the Commission will direct the Planning Director to pick an expert from a panel of licensed engineers, a list of which will be compiled, updated and maintained by the Planning Department.**

**c. No expert on the panel will be allowed to review any materials or investigate any application without first signing an agreement under penalty of perjury that the expert will keep confidential any and all information learned during the investigation of the application. No personnel currently employed by a telecommunication company are eligible for inclusion on the list.**

- d. An applicant may elect to keep confidential any proprietary information during the expert's investigation. However, if an applicant does so elect to keep confidential various items of proprietary information, that applicant may not introduce the confidential proprietary information for the first time before the Commission in support of the application.
- e. The Commission shall require that the independent expert prepare the report in a timely fashion so that it will be available to the public prior to any public hearing on the application.
- f. Should the Commission appoint an independent expert, the expert's fees will be paid by the applicant through the application fee, imposed by the City.

A Major Conditional Use Permit is required and the Planning Director or Planning Commission may therefore independent expert review in addition to that which is attached to this report.

**REGULAR DESIGN REVIEW CRITERIA FOR NON-RESIDENTIAL FACILITIES (OMC SEC. 17.136.050(B))**

1. That the proposal will help achieve or maintain a group of facilities which are well related to one another and which, when taken together, will result in a well-composed design, with consideration given to site, landscape, bulk, height, arrangement, texture, materials, colors, and appurtenances; the relation of these factors to other facilities in the vicinity; and the relation of the proposal to the total setting as seen from key points in the surrounding area. Only elements of design which have some significant relationship to outside appearance shall be considered, except as otherwise provided in Section 17.136.060;

Attachment to an existing structure with smallest possible components painted and texturized to match the pole will be the least intrusive design. The proposal will not create a view obstruction, will not be directly adjacent to a residential facility's primary living space windows, and will not be located on an historic or decorative structure.

2. That the proposed design will be of a quality and character which harmonizes with, and serves to protect the value of, private and public investments in the area;

The proposal will enhance essential services in a residential or commercial district.

3. That the proposed design conforms in all significant respects with the Oakland General Plan and with any applicable design review guidelines or criteria, district plan, or development control map which have been adopted by the Planning Commission or City Council.

This finding is met by the proposal as described in a previous section of this Attachment.

**DESIGN REVIEW CRITERIA FOR MONOPOLE TELECOMMUNICATIONS FACILITIES (OMC SEC. 17.128.070(B))**

1. Collocation is to be encouraged when it will decrease visual impact and collocation is to be discouraged when it will increase negative visual impact.

The project does not involve collocation as it involves the establishment of a new telecommunications facility; however, the project should not preclude any future proposals for location at the site.

2. Monopoles should not be sited to create visual clutter or negatively affect specific views.

The Monopole Facility is sited on existing infrastructure where it will not create clutter or negatively affect specific views.

**3. Monopoles shall be screened from the public view wherever possible.**

The Monopole Facility will be camouflaged and texturized to match the appearance of the existing light pole that will host it.

**4. The equipment shelter or cabinet must be concealed from public view or made compatible with the architecture of the surrounding structures or placed underground. The shelter or cabinet must be regularly maintained.**

Recommended conditions of approval require painting and texturing the antenna and equipment to match the appearance of the metal pole. There is no equipment shelter or cabinet proposed, however minimal equipment would be closely mounted on the side of the metal pole.

**5. Site location and development shall preserve the preexisting character of the surrounding buildings and land uses and the zone district as much as possible. Wireless communication towers shall be integrated through location and design to blend in with the existing characteristics of the site to the extent practical. Existing on-site vegetation shall be preserved or improved, and disturbance of the existing topography shall be minimized, unless such disturbance would result in less visual impact of the site to the surrounding area.**

The proposed Monopole Facility will be placed in an existing non-decorative City light pole. This enables the preservation of character in the area and will not pose a negative visual impact as the proposal will be camouflaged to match the pole. There is no adjacent vegetation or topography.

**6. That all reasonable means of reducing public access to the antennas and equipment has been made, including, but not limited to, placement in or on buildings or structures, fencing, anti-climbing measures and anti-tampering devices.**

The minimal clearance to the facility will reduce or eliminate public access.

**VARIANCE PROCEDURE/FINDINGS REQUIRED (OMC SEC. 17.148.050)**

**1. That strict compliance with the specified regulation would result in practical difficulty or unnecessary hardship inconsistent with the purposes of the zoning regulations, due to unique physical or topographic circumstances or conditions of design; or, as an alternative in the case of a minor variance, that such strict compliance would preclude an effective design solution improving livability, operational efficiency, or appearance.**

For Sites # 2 the project requires a Minor Variance. The proposal does not meet the following requirement:

*When a monopole is in a Residential Zone or adjacent to a residential use, it must be set back from the nearest residential lot line a distance at least equal to its total height. (OMC Sec. 17.128.0809(A)(3))*

The pole is not set back a depth equivalent to or greater than its height from the residential property line at 3426 Champion Street. Under the project, the pole will be extended to 33'-2" in height. The proximity to a residential property line is justified as the top of the pole is higher than and not in line with the upper story bed rooms windows at the adjacent home; the project should not therefore obstruct views or be excessively close to the windows. The proposal will provide an essential service with a least-intrusive possible design.

**2. That strict compliance with the regulations would deprive the applicant of privileges enjoyed by owners of similarly zoned property; or, as an alternative in the case of a minor variance, that such strict compliance would preclude an effective design solution fulfilling the basic intent of the applicable regulation.**

The intent of the ordinance is to avoid the installation of a looming structure adjacent to a home and to avoid clutter. A code conforming alternative in this case might consist of installation of a new shorter structure with equipment attached lower and closer to the public right-of-way, rather than using an existing City street light pole. The proposal will enhance essential services with the least-intrusive design.

**3. That the variance, if granted, will not adversely affect the character, livability, or appropriate development of abutting properties or the surrounding area, and will not be detrimental to the public welfare or contrary to adopted plans or development policy.**

The variance will eliminate the need to install a new pole.

**4. That the variance will not constitute a grant of special privilege inconsistent with limitations imposed on similarly zoned properties or inconsistent with the purposes of the zoning regulations.**

Other telecommunications facilities have been granted a similar variance.

**5. That the elements of the proposal requiring the variance (e.g., elements such as buildings, walls, fences, driveways, garages and carports, etc.) conform with the regular design review criteria set forth in the design review procedure at Section 17.136.050**

This finding is met by this proposal as described in a previous section of this attachment.

**6. That the proposal conforms in all significant respects with the Oakland General Plan and with any other applicable guidelines or criteria, district plan, or development control map which have been adopted by the Planning Commission or City Council.**

This finding is met by this proposal as described in a previous section of this attachment.

**7. For proposals involving one (1) or two (2) residential dwelling units on a lot: That, if the variance would relax a regulation governing maximum height, minimum yards, maximum lot coverage or maximum floor area ratio, the proposal also conforms with at least one of the following additional criteria:**

**a. The proposal when viewed in its entirety will not adversely impact abutting residences to the side, rear, or directly across the street with respect to solar access, view blockage and privacy to a degree greater than that which would be possible if the residence were built according to the applicable regulation and, for height variances, the proposal provides detailing, articulation or other design treatments that mitigate any bulk created by the additional height; or**

**b. Over sixty percent (60%) of the lots in the immediate vicinity are already developed and the proposal does not exceed the corresponding as-built condition on these lots and, for height variances, the proposal provides detailing, articulation or other design treatments that mitigate any bulk created by the additional height. The immediate context shall consist of the five (5) closest lots on each side of the project site plus the ten (10) closest lots on the opposite side of the street (see illustration I-4b); however, the Director of City Planning may make an alternative determination of immediate context based on specific site conditions. Such determination shall be in writing and included as part of any decision on any variance.**

This finding is non-applicable to the project; the proposal does not involve a house or duplex.

**Attachment B: Conditions of Approval**

**1. Approved Use**

The project shall be constructed and operated in accordance with the authorized use as described in the approved application materials, **staff report** and the approved plans and revised plans **dated May 31, 2017 and June 7, 2018 and submitted December 28, 2017-January 12, 2018**, as amended by the following conditions of approval and mitigation measures, if applicable (“Conditions of Approval” or “Conditions”).

**Two (2) approvals to install new “small cell site” Monopole Telecommunications Facilities on an existing City street light pole in public right-of-way (sidewalk) by attaching an antenna within a shroud to the top of the pole and equipment mounted to the side of the pole adjacent to:**

City street light poles in public right-of-way adjacent to:

1) **Site # 1: Case no. PLN17510; 2215 Champion Street**

2) **Site # 2: Case no. PLN18029; 3426 Champion Street**

**2. Effective Date, Expiration, Extensions and Extinguishment**

This Approval shall become effective immediately, unless the Approval is appealable, in which case the Approval shall become effective in ten calendar days unless an appeal is filed. Unless a different termination date is prescribed, this Approval shall expire **two calendar years** from the Approval date, or from the date of the final decision in the event of an appeal, unless within such period all necessary permits for construction or alteration have been issued, or the authorized activities have commenced in the case of a permit not involving construction or alteration. Upon written request and payment of appropriate fees submitted no later than the expiration date of this Approval, the Director of City Planning or designee may grant a one-year extension of this date, with additional extensions subject to approval by the approving body. Expiration of any necessary building permit or other construction-related permit for this project may invalidate this Approval if said Approval has also expired. If litigation is filed challenging this Approval, or its implementation, then the time period stated above for obtaining necessary permits for construction or alteration and/or commencement of authorized activities is automatically extended for the duration of the litigation.

**3. Compliance with Other Requirements**

The project applicant shall comply with all other applicable federal, state, regional, and local laws/codes, requirements, regulations, and guidelines, including but not limited to those imposed by the City’s Bureau of Building, Fire Marshal, and Public Works Department. Compliance with other applicable requirements may require changes to the approved use and/or plans. These changes shall be processed in accordance with the procedures contained in Condition #4.

**4. Minor and Major Changes**

- a. Minor changes to the approved project, plans, Conditions, facilities, or use may be approved administratively by the Director of City Planning.
- b. Major changes to the approved project, plans, Conditions, facilities, or use shall be reviewed by the Director of City Planning to determine whether such changes require submittal and approval of a revision to the Approval by the original approving body or a new independent permit/approval. Major revisions shall be reviewed in accordance with the procedures required for the original permit/approval. A new independent permit/approval shall be reviewed in accordance with the procedures required for the new permit/approval.

**EXHIBIT B**

### **5. Compliance with Conditions of Approval**

- a. The project applicant and property owner, including successors, (collectively referred to hereafter as the "project applicant" or "applicant") shall be responsible for compliance with all the Conditions of Approval and any recommendations contained in any submitted and approved technical report at his/her sole cost and expense, subject to review and approval by the City of Oakland.
- b. The City of Oakland reserves the right at any time during construction to require certification by a licensed professional at the project applicant's expense that the as-built project conforms to all applicable requirements, including but not limited to, approved maximum heights and minimum setbacks. Failure to construct the project in accordance with the Approval may result in remedial reconstruction, permit revocation, permit modification, stop work, permit suspension, or other corrective action.
- c. Violation of any term, Condition, or project description relating to the Approval is unlawful, prohibited, and a violation of the Oakland Municipal Code. The City of Oakland reserves the right to initiate civil and/or criminal enforcement and/or abatement proceedings, or after notice and public hearing, to revoke the Approval or alter these Conditions if it is found that there is violation of any of the Conditions or the provisions of the Planning Code or Municipal Code, or the project operates as or causes a public nuisance. This provision is not intended to, nor does it, limit in any manner whatsoever the ability of the City to take appropriate enforcement actions. The project applicant shall be responsible for paying fees in accordance with the City's Master Fee Schedule for inspections conducted by the City or a City-designated third-party to investigate alleged violations of the Approval or Conditions.

### **6. Signed Copy of the Approval/Conditions**

A copy of the Approval letter and Conditions shall be signed by the project applicant, attached to each set of permit plans submitted to the appropriate City agency for the project, and made available for review at the project job site at all times.

### **7. Blight/Nuisances**

The project site shall be kept in a blight/nuisance-free condition. Any existing blight or nuisance shall be abated within 60 days of approval, unless an earlier date is specified elsewhere.

### **8. Indemnification**

- a. To the maximum extent permitted by law, the project applicant shall defend (with counsel acceptable to the City), indemnify, and hold harmless the City of Oakland, the Oakland City Council, the Oakland Redevelopment Successor Agency, the Oakland City Planning Commission, and their respective agents, officers, employees, and volunteers (hereafter collectively called "City") from any liability, damages, claim, judgment, loss (direct or indirect), action, causes of action, or proceeding (including legal costs, attorneys' fees, expert witness or consultant fees, City Attorney or staff time, expenses or costs) (collectively called "Action") against the City to attack, set aside, void or annul this Approval or implementation of this Approval. The City may elect, in its sole discretion, to participate in the defense of said Action and the project applicant shall reimburse the City for its reasonable legal costs and attorneys' fees.



- b. Within ten (10) calendar days of the filing of any Action as specified in subsection (a) above, the project applicant shall execute a Joint Defense Letter of Agreement with the City, acceptable to the Office of the City Attorney, which memorializes the above obligations. These obligations and the Joint Defense Letter of Agreement shall survive termination, extinguishment, or invalidation of the Approval. Failure to timely execute the Letter of Agreement does not relieve the project applicant of any of the obligations contained in this Condition or other requirements or Conditions of Approval that may be imposed by the City.

#### **9. Severability**

The Approval would not have been granted but for the applicability and validity of each and every one of the specified Conditions, and if one or more of such Conditions is found to be invalid by a court of competent jurisdiction this Approval would not have been granted without requiring other valid Conditions consistent with achieving the same purpose and intent of such Approval.

#### **10. Job Site Plans**

*Ongoing throughout demolition, grading, and/or construction*

At least one (1) copy of the stamped approved plans, along with the Approval Letter and Conditions of Approval, shall be available for review at the job site at all times.

#### **11. Special Inspector/Inspections, Independent Technical Review, Project Coordination and Monitoring**

The project applicant may be required to cover the full costs of independent third-party technical review and City monitoring and inspection, including without limitation, special inspector(s)/inspection(s) during times of extensive or specialized plan-check review or construction, and inspections of potential violations of the Conditions of Approval. The project applicant shall establish a deposit with the Bureau of Building, if directed by the Building Official, Director of City Planning, or designee, prior to the issuance of a construction-related permit and on an ongoing as-needed basis.

#### **12. Public Improvements**

The project applicant shall obtain all necessary permits/approvals, such as encroachment permits, obstruction permits, curb/gutter/sidewalk permits, and public improvement ("p-job") permits from the City for work in the public right-of-way, including but not limited to, streets, curbs, gutters, sidewalks, utilities, and fire hydrants. Prior to any work in the public right-of-way, the applicant shall submit plans for review and approval by the Bureau of Planning, the Bureau of Building, and other City departments as required. Public improvements shall be designed and installed to the satisfaction of the City.

#### **13. Construction Days/Hours**

Requirement: The project applicant shall comply with the following restrictions concerning construction days and hours:

- a. Construction activities are limited to between 7:00 a.m. and 7:00 p.m. Monday through Friday, except that pier drilling and/or other extreme noise generating activities greater than 90 dBA shall be limited to between 8:00 a.m. and 4:00 p.m.
- b. Construction activities are limited to between 9:00 a.m. and 5:00 p.m. on Saturday. In residential zones and within 300 feet of a residential zone, construction activities are allowed from 9:00 a.m. to 5:00 p.m. only within the interior of the building with the doors and windows closed. No pier drilling or other extreme noise generating activities greater than 90 dBA are allowed on Saturday.

c. No construction is allowed on Sunday or federal holidays.

Construction activities include, but are not limited to, truck idling, moving equipment (including trucks, elevators, etc.) or materials, deliveries, and construction meetings held on-site in a non-enclosed area.

Any construction activity proposed outside of the above days and hours for special activities (such as concrete pouring which may require more continuous amounts of time) shall be evaluated on a case-by-case basis by the City, with criteria including the urgency/emergency nature of the work, the proximity of residential or other sensitive uses, and a consideration of nearby residents'/occupants' preferences. The project applicant shall notify property owners and occupants located within 300 feet at least 14 calendar days prior to construction activity proposed outside of the above days/hours. When submitting a request to the City to allow construction activity outside of the above days/hours, the project applicant shall submit information concerning the type and duration of proposed construction activity and the draft public notice for City review and approval prior to distribution of the public notice.

When Required: During construction

Initial Approval: N/A

Monitoring/Inspection: Bureau of Building

## **PROJECT-SPECIFIC CONDITIONS**

### **14. Emissions Report**

Requirement: A RF emissions report shall be submitted to the Planning Bureau indicating that the site is actually operating within the acceptable thresholds as established by the Federal government or any such agency who may be subsequently authorized to establish such standards.

Requirement: Prior to a final inspection

When Required: Prior to final building permit inspection sign-off

Initial Approval: N/A

Monitoring/Inspection: N/A

### **15. Camouflage**

Requirement: The antenna and equipment shall be painted, texturized, and maintained the same color and finish of the City light pole.

When Required: Prior to a final inspection

Initial Approval: N/A

Monitoring/Inspection: Bureau of Building

### **16. Operational**

Requirement: Noise levels from the activity, property, or any mechanical equipment on site shall comply with the performance standards of Section 17.120 of the Oakland Planning Code and Section 8.18 of the Oakland Municipal Code. If noise levels exceed these standards, the activity causing the noise shall be abated until appropriate noise reduction measures have been installed and compliance verified by the Planning and Zoning Division and Building Services.

When Required: Ongoing

Initial Approval: N/A

Monitoring/Inspection: Bureau of Building

**17. Graffiti Control**

Requirement:

- a. During construction and operation of the project, the project applicant shall incorporate best management practices reasonably related to the control of graffiti and/or the mitigation of the impacts of graffiti. Such best management practices may include, without limitation:
- b. The project applicant shall remove graffiti by appropriate means within seventy-two (72) hours. Appropriate means include the following:
  - i. Removal through scrubbing, washing, sanding, and/or scraping (or similar method) without damaging the surface and without discharging wash water or cleaning detergents into the City storm drain system.
  - ii. For galvanized poles, covering with new paint to match the color of the surrounding surface.
  - iii. Replace pole numbers.

When Required: Ongoing

Initial Approval: N/A

Monitoring/Inspection: Bureau of Building



intelligent infrastructure

SITE ID/CASCADE ID-CANDIDATE LETTER:

9CAB013243/SF90XS0F1C

LATITUDE/LONGITUDE:

37.80011/-122.21617

CROSS STREET:

FRUITVALE AVE. & MCARTHUR BLVD.

CITY, STATE, ZIP:

OAKLAND, CA 94602

**(E) 26'-0" STEEL LIGHT POLE**



IF YOU DIG IN ANY STATE  
DIAL 811 FOR THE LOCAL  
"ONE CALL CENTER" -  
IT'S THE LAW

THE UTILITIES SHOWN HEREIN ARE FOR THE CONTRACTOR'S  
CONVENIENCE ONLY. THERE MAY BE OTHER UTILITIES NOT SHOWN  
ON THESE PLANS. THE ENGINEER/SURVEYOR ASSUMES NO  
RESPONSIBILITY FOR THE LOCATION OF UTILITIES. IT SHALL BE  
THE CONTRACTOR'S RESPONSIBILITY TO VERIFY ALL THE UTILITIES  
WITHIN THE LIMITS OF THE WORK. ALL DAMAGE MADE TO THE UTILITY  
UTILITIES BY THE CONTRACTOR SHALL BE THE SOLE  
RESPONSIBILITY OF THE CONTRACTOR.

GENERAL NOTES

THE FACILITY IS UNMANNED AND NOT FOR HUMAN HABITATION. A  
TECHNICIAN WILL VISIT THE SITE AS REQUIRED FOR ROUTINE  
MAINTENANCE. THE PROJECT WILL NOT RESULT IN ANY SIGNIFICANT  
DISTURBANCE OF EFFECT ON DRAINAGE; NO SANITARY SEWER  
SERVICE, POTABLE WATER OR TRASH DISPOSAL IS REQUIRED AND  
NO COMMERCIAL SIGNAGE IS (N).

SITE INFORMATION

SITE ID:	9CAB013243
CASCADE ID:	SF90XS0F1C
LATITUDE:	37.80011
LONGITUDE:	-122.21617
CROSS STREET:	FRUITVALE AVE. & MCARTHUR BLVD.
CITY, STATE, ZIP:	OAKLAND, CA 94602
COUNTY:	ALAMEDA COUNTY
	CITY OF OAKLAND
	PUBLIC RIGHT-OF-WAY
	MOBILITIE, LLC 2955 RED HILL AVENUE STE 200, COSTA MESA, CA 92626 APPLICANT: JAMES SINGLETON PHONE: 605-814-0584 EMAIL: jsingleton@mobilitie.com

ENGINEER

SERVICES JEREMY HARMON  
D. SUITE 1 (818) 898-2352  
345

NOT SCALE DRAWINGS

VERIFY ALL PLANS, (E) DIMENSIONS & FIELD  
ON SITE & SHALL IMMEDIATELY NOTIFY THE  
ENGINEER IN WRITING OF ANY DISCREPANCIES BEFORE  
WORK OR BE RESPONSIBLE FOR SAME.

LOCATION MAPS

VICINITY MAP



REGIONAL MAP

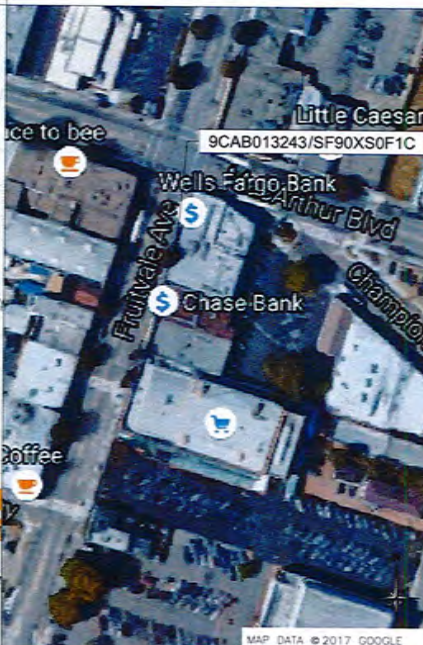

PROJECT DESCRIPTION

END USER PROPOSES TO INSTALL EQUIPMENT ON AN EXISTING  
STEEL POLE WITHIN AN EXISTING RIGHT-OF-WAY.  
THE SCOPE WILL CONSIST OF THE FOLLOWING:  
- INSTALL PROPOSED SMALL SCALE WIRELESS EQUIPMENT ON AN  
EXISTING STEEL LIGHT POLE

CODES

2015 INTERNATIONAL BUILDING CODE  
2017 NATIONAL ELECTRICAL CODE  
TIA/EIA-222-G-2 OR LATEST EDITION  
LOCAL BUILDING/PLANNING CODE

DRAWING INDEX

SHEET NO:	TITLE SHEET
T-1	TITLE SHEET
SP-1	EXHIBIT PHOTO & SITE PLAN
SP-2	OVERALL SITE PLAN
EV-1	POLE ELEVATIONS
EV-2	POLE ELEVATIONS
PL-1	PLUMBING & RISER DIAGRAM
EQ-1	EQUIPMENT DETAILS
EQ-2	EQUIPMENT DETAILS
E-1	ELECTRICAL DETAILS
G-1	GROUNDING DETAILS
GN-1	GENERAL NOTES
GN-2	GENERAL NOTES
GN-3	GENERAL NOTES
TC-1	TRAFFIC CONTROL PLAN



PRESCOTT COMMUNICATIONS INC.  
15640 Sepulveda Blvd. Suite 1, Mission Hills, CA 91345  
Phone No. (818) 926-2322 Fax No. (818) 926-4196

PROJECT NO:	9CAB013243
DRAWN BY:	MD
CHECKED BY:	JM

0	05/25/17	90% CONSTRUCTION
1	05/25/17	ADDED SMART METER
2	09/26/17	REVISED PER PDM STANDARDS

IT IS A VIOLATION OF THE LAW FOR ANY  
PERSON, UNLESS THEY ARE ACTING UNDER THE  
DIRECTION OF A LICENSED PROFESSIONAL  
ENGINEER, TO ALTER THIS DOCUMENT

9CAB013243  
OAKLAND, CA 94602  
(E) 26'-0" STEEL LIGHT POLE

SHEET TITLE  
TITLE SHEET

SHEET NUMBER  
T-1

EXHIBIT C

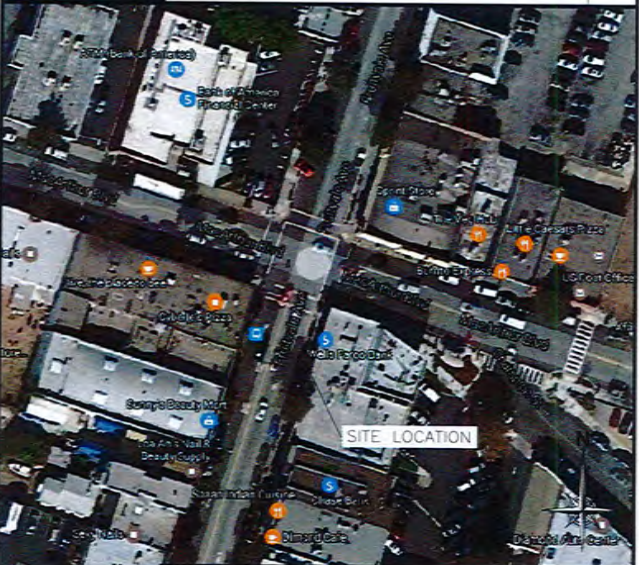



**EXHIBIT PHOTO**

SCALE: NOT TO SCALE

1



**AERIAL SITE LOCATION**

SCALE: NOT TO SCALE

2

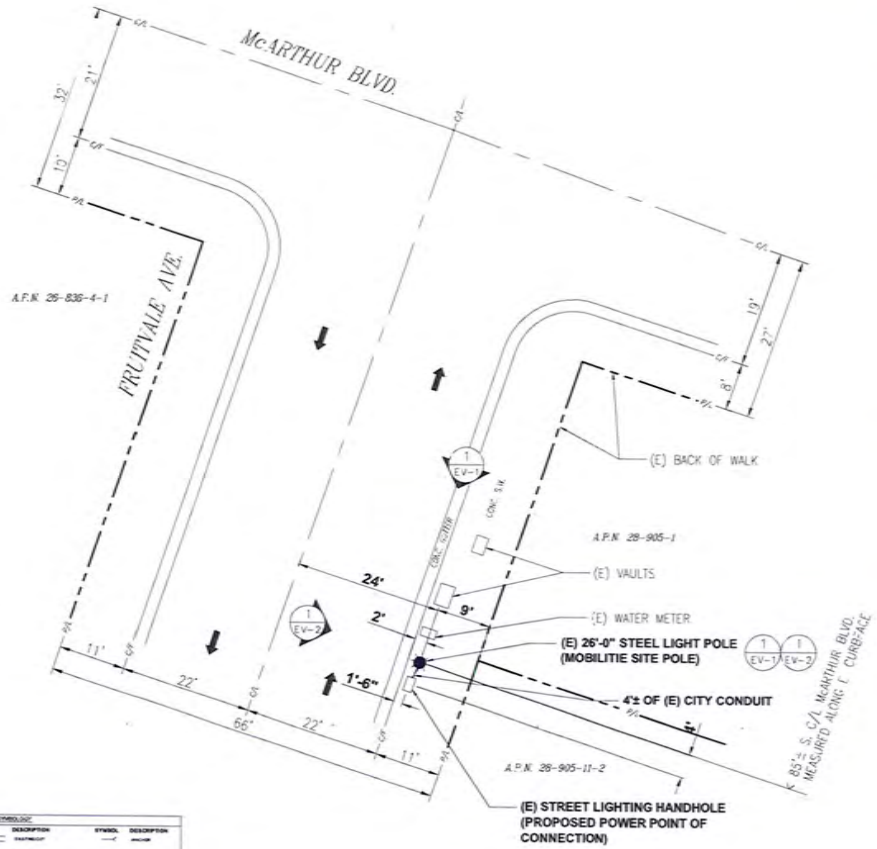

SYMBOL DESCRIPTION			
SYMBOL	DESCRIPTION	SYMBOL	DESCRIPTION
---	CONCRETE	---	ASBESTOS
---	CEMENT	---	STEEL
---	BRICK	---	GLASS
---	WOOD	---	PLASTER
---	ROOFING	---	PAINT
---	...	---	...

**UNDERGROUND UTILITIES NOTE:**  
 THE LOCATIONS AND EXISTENCE OF ANY UNDERGROUND PIPES, STRUCTURES OR CONDUITS SHOWN ON THIS PLAN WERE OBTAINED BY A SEARCH OF AVAILABLE RECORDS. THERE MAY BE EX. UTILITIES OTHER THAN THOSE SHOWN ON THIS PLAN. THE CONTRACTOR IS REQUIRED TO TAKE PRECAUTIONARY MEASURES TO PROTECT THE UTILITY LINES SHOWN AND ANY OTHER LINES NOT SHOWN ON THIS PLAN.

**CONSTRUCTION NOTE:**  
 CONTRACTOR TO TAP IN AT THE POC AND RUN A NEW, SEPARATE CIRCUIT THROUGH CITY CONDUIT TO GO TO THE POLE.

**ENLARGED SITE PLAN**

SCALE: 1" = 10'



3



PRESCOTT COMMUNICATIONS, INC.  
 10640 Sequoia Blvd. Suite 1, Mission Hills, CA 91345  
 Phone No.: (818) 938-2252 Fax No.: (818) 938-9188

PROJECT NO: 9CAB013243  
 DRAWN BY: MD  
 CHECKED BY: JM

NO.	DATE	DESCRIPTION
1	05/21/17	ADD SMART METER
2	09/26/17	REVISED PER POAE STANDARDS

IT IS A VIOLATION OF THE LAW FOR ANY PERSON, UNLESS THEY ARE ACTING UNDER THE DIRECTION OF A LICENSED PROFESSIONAL ENGINEER, TO ALTER THIS DOCUMENT.

9CAB013243  
 OAKLAND, CA 94602  
 (E) 26'-0" STEEL LIGHT POLE

SHEET TITLE  
**EXHIBIT PHOTO & SITE PLAN**

SHEET NUMBER  
**SP-1**

REV	DATE	DESCRIPTION
0	05/26/17	POE CONSTRUCTION
1	05/21/17	ADDED SMART METER
2	09/26/17	REVISED PER POE STANDARDS

IT IS A VIOLATION OF THE LAW FOR ANY PERSON UNLESS THEY ARE ACTING UNDER THE DIRECTION OF A LICENSED PROFESSIONAL ENGINEER, TO ALTER THIS DOCUMENT.

9CAB013243  
OAKLAND, CA 94602  
(E) 26'-0" STEEL LIGHT POLE

SHEET TITLE  
OVERALL SITE PLAN

SHEET NUMBER  
SP-2

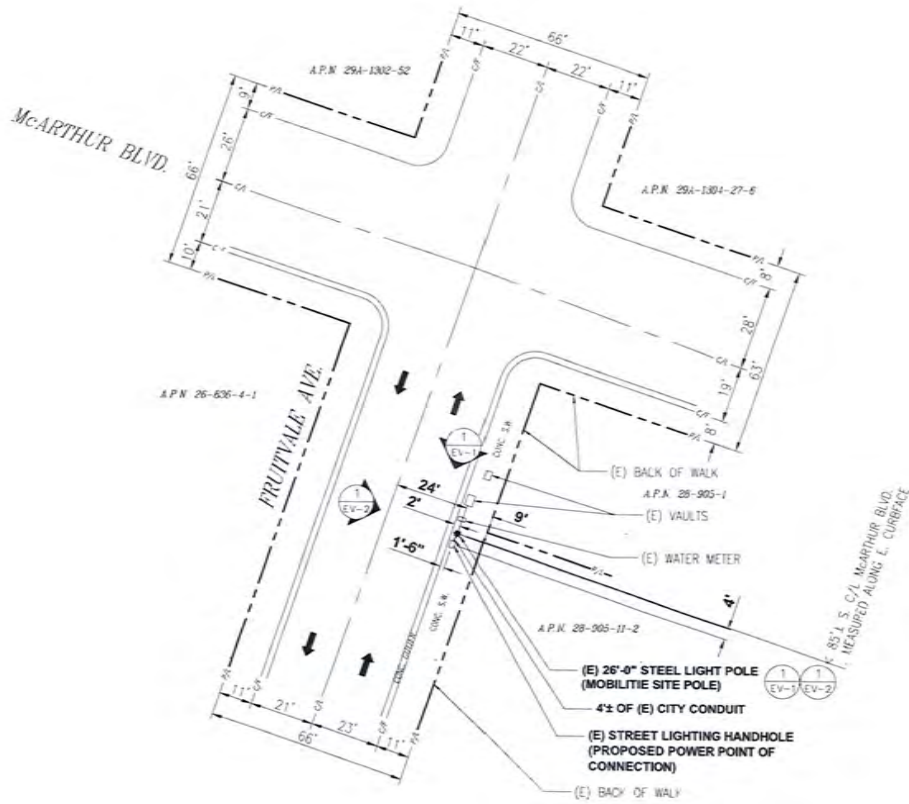

SYMBOL		
SYMBOL	DESCRIPTION	SYMBOL
(Symbol)	UNDERGROUND UTILITY	(Symbol)
(Symbol)	CONDUIT	(Symbol)
(Symbol)	VAULT	(Symbol)
(Symbol)	WATER METER	(Symbol)
(Symbol)	BACK OF WALK	(Symbol)
(Symbol)	STREET LIGHTING HANDHOLE	(Symbol)
(Symbol)	STEEL LIGHT POLE	(Symbol)
(Symbol)	CITY CONDUIT	(Symbol)
(Symbol)	SMART METER	(Symbol)

**UNDERGROUND UTILITIES NOTE:**  
THE LOCATIONS AND EXISTENCE OF ANY UNDERGROUND PIPES, STRUCTURES OR CONDUITS SHOWN ON THIS PLAN WERE OBTAINED BY A SEARCH OF AVAILABLE RECORDS. THERE MAY BE EX. UTILITIES OTHER THAN THOSE SHOWN ON THIS PLAN. THE CONTRACTOR IS REQUIRED TO TAKE PRECAUTIONARY MEASURES TO PROTECT THE UTILITY LINES SHOWN AND ANY OTHER LINES NOT SHOWN ON THIS PLAN.

**CONSTRUCTION NOTE:**  
CONTRACTOR TO TAP IN AT THE POC AND RUN A NEW, SEPARATE CIRCUIT THROUGH CITY CONDUIT TO GO TO THE POLE.



**OVERALL SITE PLAN**  
SCALE: 1" = 20'



**PG&E METERING AND SERVICE CONNECTIONS FOR NON-PG&E OWNED STEEL STREETLIGHT POLES WITH ANTENNA AND COMMUNICATION EQUIPMENT**

5. A DISCONNECT SWITCH MUST BE INSTALLED AND MEETS ALL OF THE FOLLOWING REQUIREMENTS BELOW. THE SWITCH WILL BE USED AS PART OF THE NORMAL OR EMERGENCY SHUTDOWN PROTOCOLS REQUIRED IN CALIFORNIA PUBLIC UTILITY COMMISSION (CPUC) GENERAL ORDER 95, RULE 94.
- 5.1. THE SWITCH SHALL DE-ENERGIZE ALL POWER SUPPLIES, INCLUDING BACK-UP POWER, AND ANY COMMUNICATION EQUIPMENT EMITTING RADIO FREQUENCIES (RF).
  - 5.2. THE SWITCH MUST NOT DE-ENERGIZE (TURN OFF) THE STREET LIGHT(S).
  - 5.3. THE SWITCH MUST BE READILY ACCESSIBLE AND ATTACHED EXTERNALLY ON THE POLE LESS THAN 10 FEET ABOVE GRADE, AS MEASURED TO THE TOP OF THE SWITCH ENCLOSURE.
  - 5.4. THE SWITCH MAY NOT BE INSTALLED INSIDE THE POLE, IN THE BASE OF THE POLE, OR IN A SUBSURFACE ENCLOSURE.
  - 5.5. PROVISIONS FOR LOCKING THE DISCONNECT SWITCH IN THE OFF POSITION ARE REQUIRED.

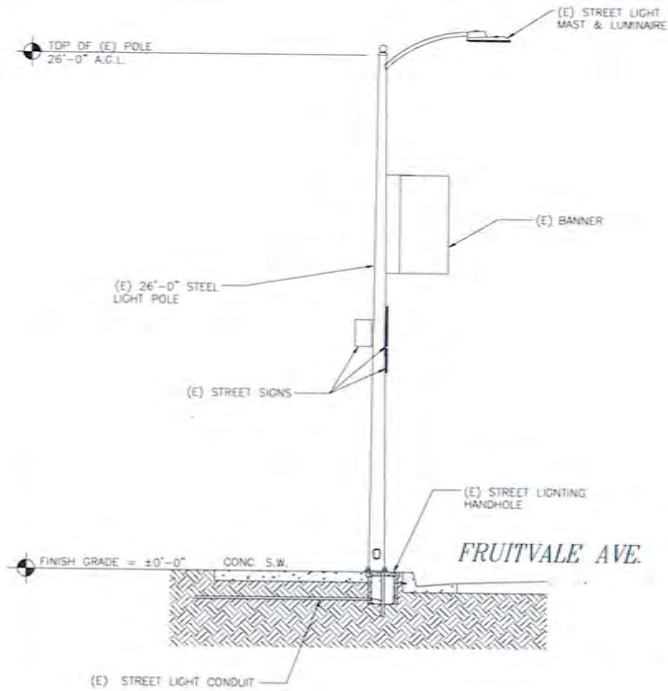

**EXISTING SIDE VIEW**

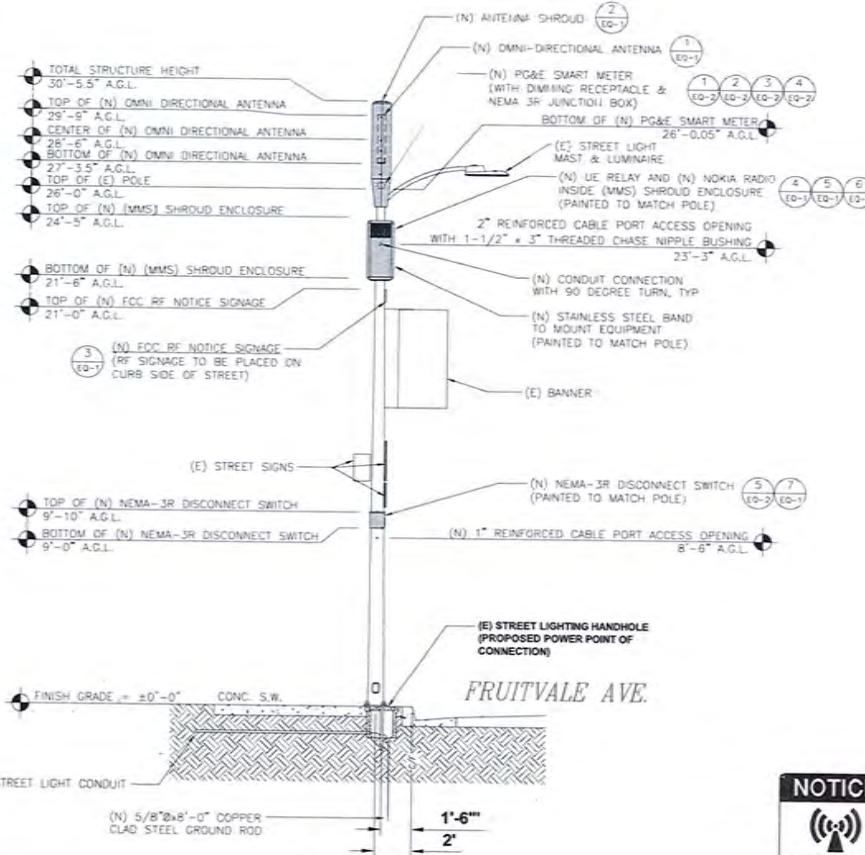

**NEW SIDE VIEW**

**NOTES:**

1. ALL HARDWARE SHALL BE STAINLESS STEEL.
2. ALL CABLES SHALL BE SECURED TO POLE EVERY 36" OR LESS.
3. LIGHTNING RODS SHALL BE INCLUDED AS REQUIRED.
4. STRUCTURAL BACKFILL TO BE COMPACTED IN 6" MAXIMUM LAYERS TO 95% OF CONTENT IN ACCORDANCE WITH ASTM D998, ADDITIONALLY, STRUCTURAL BACKFILL MUST HAVE A MINIMUM COMPACTED UNIT WEIGHT OF 100 POUNDS PER CUBIC FOOT (16kN/m<sup>3</sup>).

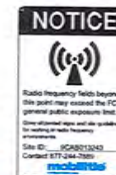

- BY MARKING SIGN WILL BE PAINTED TO MATCH NEW POLE.
- SIGN TO BE NO LARGER THAN 3" x 4".
- SIGN TO BE MOUNTED ON CURB SIDE.

**POLE ELEVATIONS**

SCALE: 1" = 3'

1



PRESCOTT COMMUNICATIONS, INC.  
10640 Sepulveda Blvd. Suite 1, Mission Hills, CA 91345  
Phone No.: (818)228-2202 Fax No.: (818)228-0166

PROJECT NO: 9CAB013243

DRAWN BY: MD

CHECKED BY: JM

REV	DATE	DESCRIPTION
2	05/26/17	REVISED PER PG&E STANDARDS
1	05/21/17	ADDED SMART METER
2	09/26/17	REVISED PER PG&E STANDARDS

IT IS A VIOLATION OF THE LAW FOR ANY PERSON UNLESS THEY ARE ACTING UNDER THE DIRECTION OF A LICENSED PROFESSIONAL ENGINEER TO ALTER THIS DOCUMENT

9CAB013243  
OAKLAND, CA 94602  
(E) 26'-0" STEEL LIGHT POLE

SHEET TITLE  
**POLE ELEVATIONS**

SHEET NUMBER  
**EV-1**

**PG&E METERING AND SERVICE CONNECTIONS FOR NON-PG&E OWNED STEEL STREETLIGHT POLES WITH ANTENNA AND COMMUNICATION EQUIPMENT**

5. A DISCONNECT SWITCH MUST BE INSTALLED AND MEETS ALL OF THE FOLLOWING REQUIREMENTS BELOW. THE SWITCH WILL BE USED AS PART OF THE NORMAL OR EMERGENCY SHUTDOWN PROTOCOLS REQUIRED IN CALIFORNIA PUBLIC UTILITY COMMISSION (CPUC) GENERAL ORDER 95, RULE 94.
- 5.1. THE SWITCH SHALL DE-ENERGIZE ALL POWER SUPPLIES, INCLUDING BACK-UP POWER, AND ANY COMMUNICATION EQUIPMENT EMITTING RADIO FREQUENCIES (RF).
- 5.2. THE SWITCH MUST NOT DE-ENERGIZE (TURN OFF) THE STREET LIGHT(S).
- 5.3. THE SWITCH MUST BE READILY ACCESSIBLE AND ATTACHED EXTERNALLY ON THE POLE LESS THAN 10 FEET ABOVE GRADE, AS MEASURED TO THE TOP OF THE SWITCH ENCLOSURE.
- 5.4. THE SWITCH MAY NOT BE INSTALLED INSIDE THE POLE, IN THE BASE OF THE POLE, OR IN A SUBSURFACE ENCLOSURE.
- 5.5. PROVISIONS FOR LOCKING THE DISCONNECT SWITCH IN THE OFF POSITION ARE REQUIRED.

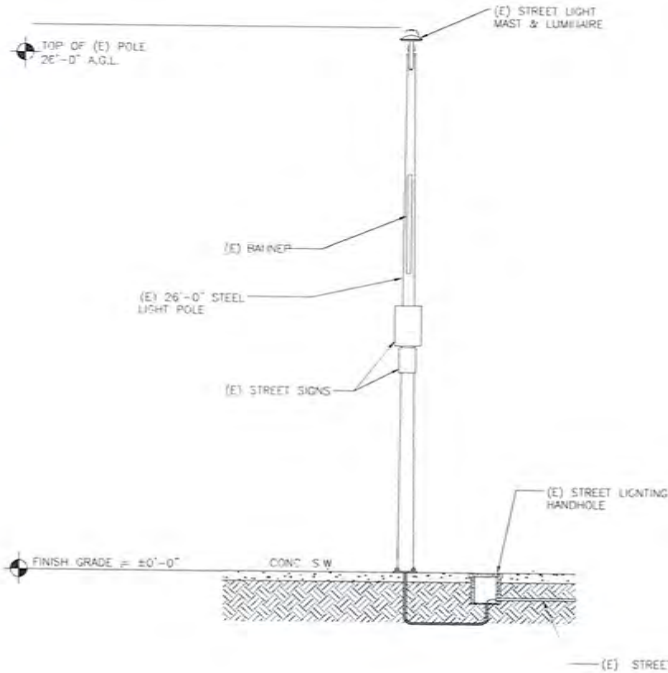

**EXISTING FRONT VIEW**

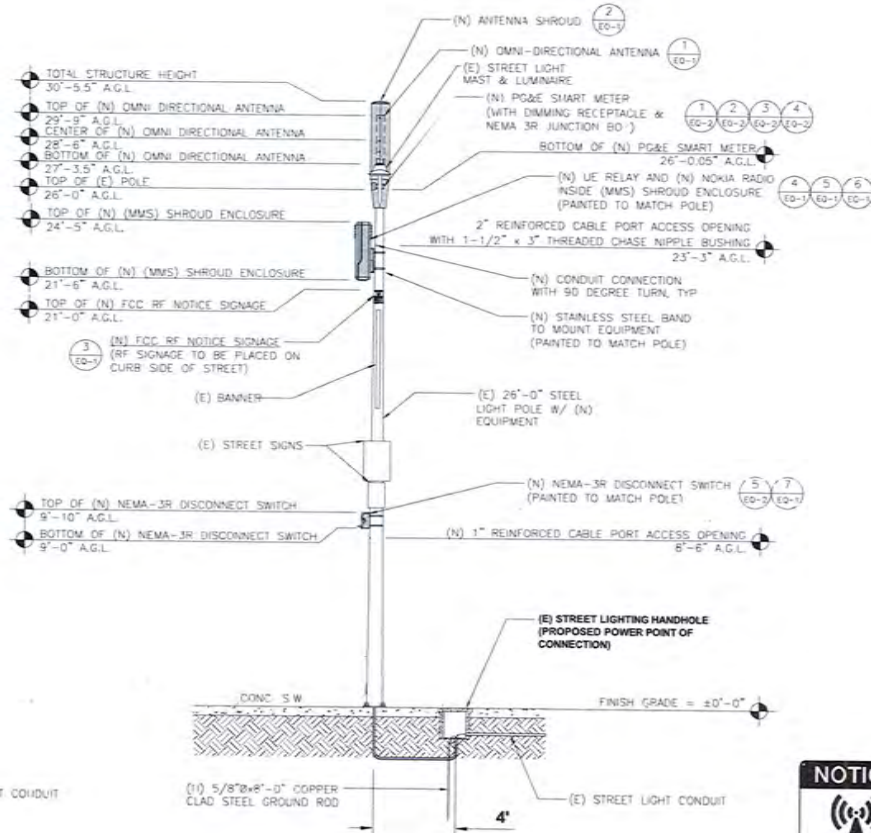

**NEW FRONT VIEW**

**NOTES:**

1. ALL HARDWARE SHALL BE STAINLESS STEEL.
2. ALL CABLES SHALL BE SECURED TO POLE EVERY 36" OR LESS.
3. LIGHTNING RODS SHALL BE INCLUDED AS REQUIRED.
4. STRUCTURAL BACKFILL TO BE COMPACTED IN 6" MAXIMUM LAYERS TO 95% OF CONTENT IN ACCORDANCE WITH ASTM D598. ADDITIONALLY, STRUCTURAL BACKFILL MUST HAVE A MINIMUM COMPACTED UNIT WEIGHT OF 100 POUNDS PER CUBIC FOOT (16kN/m<sup>3</sup>).



- ALL WARNING SIGNS WILL BE PAINTED TO MATCH POLE.
- SIGNS TO BE NO LARGER THAN 12"x12".
- SIGNS TO BE MOUNTED ON CURB SIDE.

<b>POLE ELEVATIONS</b>	<b>1</b>
SCALE: 1" = 3'	



PROJECT NO:	9CAB013243
DRAWN BY:	MD
CHECKED BY:	JM

8/25/17	SSS CONSTRUCTION
1/25/17	ADDED SMART METER
2/09/17	RE-USED PER PG&E STANDARDS

IT IS A VIOLATION OF THE LAW FOR ANY PERSON, UNLESS THEY ARE ACTING UNDER THE DIRECTION OF A LICENSED PROFESSIONAL ENGINEER, TO ALTER THIS DOCUMENT.

9CAB013243  
OAKLAND, CA 94602  
(E) 26'-0" STEEL LIGHT POLE

SHEET TITLE  
**POLE ELEVATIONS**

SHEET NUMBER  
**EV-2**



**NOTE:**  
 1) CABLING DIAGRAM IS FOR CLARITY OF CABLE ROUTE AND TERMINATION ONLY. CONTRACTOR SHALL INSTALL CABLES WITH MINIMAL VISUAL IMPACT ON (E) STEEL LIGHT POLE. SEE ELEVATION DRAWING FOR EQUIPMENT AND ANTENNA LOCATIONS.

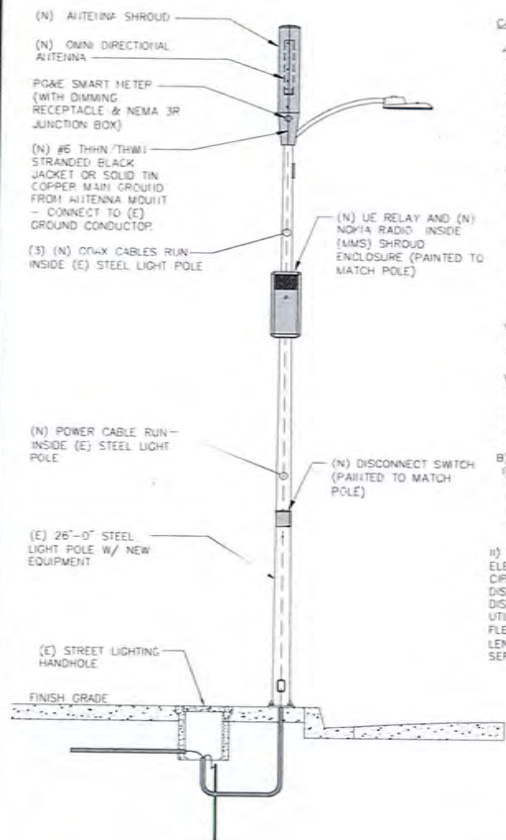

- CABLING NOTES:**
- A) WOOD, CONCRETE AND EXISTING METALLIC POLES
    - i) FROM GRADE LINE TO 11'-0" ABOVE GRADE, ALL CABLES/CONDUCTORS EXCEPT GROUNDING CONDUCTOR MUST RUN IN RIGID GALVANIZED STEEL CONDUIT (RGS)
    - ii) GROUNDING CONDUCTORS IN EXPOSED LOCATIONS MUST BE INSTALLED IN PVC.
    - iii) IN EARTH INSTALL PVC CONDUIT FOR BACKHAUL AND ELECTRICAL SERVICE. TRANSITION TO RGS AT GRADE LINE.
    - iv) ABOVE 11'-0" ALL CABLES (POWER, ETHERNET, COAXIAL) MUST RUN IN PVC UTILITY POLE RISER.
      - (1) AT MAJOR EQUIPMENT, EXTEND UTILITY DUCT IMMEDIATELY ADJACENT TO THE EQUIPMENT. INSTALL CABLES IN THE UTILITY POLE RISER CREATING CABLE DRIP LOOPS NOT LESS THAN THE CABLE BENDING RADIUS.
      - (2) INSIDE THE UTILITY POLE RISER, UTILIZE 1/2" COAX BLOCKS WITH LAG SCREWS TO SUPPORT COAX, RADIO AND MW POWER, RF COAX, AND ETHERNET CABLES TO WITHIN 12" OF THE EQUIPMENT BEING SERVED AND ON INTERVALS NOT TO EXCEED 6'.
      - v) FOR UNDERGROUND HFC/PUBLIC BACKHAUL, ROUTE ETHERNET CABLE IN CONDUIT UP THE POLE AND ENTER THE UTILITY POLE RISER. SEAL EXPOSED END OF CONDUIT WITH A CABLE TERMINATION FITTING.
      - vi) BY APPROVAL IN SELECT CASES LIQUID-TIGHT FLEXIBLE METALLIC CONDUIT (LFMC) MAY BE USED IN LENGTHS NOT TO EXCEED 36" TO EXTEND THE ELECTRICAL SERVICE CONDUIT TO THE AC DISTRIBUTION BOX. EXAMPLE: UTILITY-REQUIRED DISCONNECT ON POLE. W/ AC DISTRIBUTION BOX ON OPPOSITE SIDE OF POLE.
  - B) (N) METALLIC POLES
    - (1) PRODUCE (N) POLES WITH SUITABLE HAND HOLES SUCH THAT HAND HOLES EXIST AT ALL EQUIPMENT LOCATIONS.
      - (i) WITH CLIENT APPROVAL IN SELECT CASES TO FACILITATE IMPROVED APPEARANCE, 1/2" COAXIAL CABLES MAY BE "SUPERFLEX" IN LIEU OF LDF-4
      - (ii) WHERE POSSIBLE, INSTALL POLE BASE SUCH THAT THE ELECTRICAL FEED AND BACKHAUL (IF UNDERGROUND) CIRCUIT ENTER THE POLE THROUGH THE POLE BASE. IF A DISCONNECTING MEANS SEPARATE FROM THE AC DISTRIBUTION BOX IS REQUIRED BY JURISDICTION OR UTILITY, WITH APPROVAL IN SELECT CASES LIQUID-TIGHT FLEXIBLE METALLIC CONDUIT (LFMC) MAY BE USED IN LENGTHS NOT TO EXCEED 36" TO EXTEND THE ELECTRICAL SERVICE CONDUIT TO THE AC DISTRIBUTION BOX.

**PLUMBING DIAGRAM**  
 SCALE: NOT TO SCALE 1

EQUIPMENT CHART			
QTY.	DESCRIPTION	DIMENSIONS	WEIGHT
1	ANTENNA MODEL #PW3477-S1-C (OMNI DIRECTIONAL ANTENNA)	29.5" x 4.5"	7 LBS
1	CONCEALFAB ANTENNA SHROUD	47.375" x 17" x 10.75"	16.11 LBS
1	(MMS) SHROUD ENCLOSURE	35" x 15.5" x 9"	12 LBS
1	ALPSPAN IR460 (UE RELAY)	1.3" x 7"	8.8 LBS
1	NOKIA RADIO (B41 FWHR) HIGH POWER	7.7" x 12.9" x 6.3"	24.64 LBS
3	FANS (2 SMALL, 1 LARGER)		2.76 LBS
1	SMART METER	2.67" x 4.5"	-
1	RECEPTACLE	-	-
1	ALLEN-BRADLEY NEMA 3R JUNCTION BOX	4.53" x 2.58" x 2.17"	-
1	SIEMENS DISCONNECT SWITCH MODEL #GNF321 NEMA-3R	9.9" X 8.8" X 4.5"	5 LBS.
TOTAL WEIGHT			76.31 LBS

**EQUIPMENT CHART**  
 SCALE: NOT TO SCALE 2

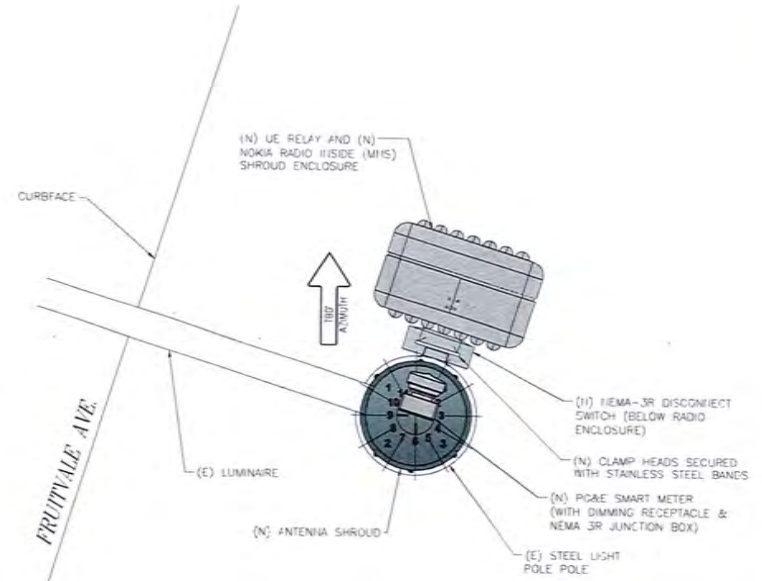

**RISER DIAGRAM**  
 SCALE: NOT TO SCALE 3

**mobilite**  
 Intelligent Infrastructure

**C&S cable engineering services**  
 PRESCOTT COMMUNICATIONS INC.  
 10640 Soquelita Blvd. Suite 1, Mission Viejo, CA 92690  
 Phone No. (949)999-2252 Fax No. (949)999-0168

PROJECT NO: SCAB013243  
 DRAWN BY: MD  
 CHECKED BY: JM

REV	DATE	DESCRIPTION
0	05/05/17	SOL CONSTRUCTION
1	05/21/17	ADD SMART METER
2	09/26/17	REISED PER POLE STANDARDS

IF IS A VIOLATION OF THE LAW FOR ANY PERSON, UNLESS THEY ARE ACTING UNDER THE DIRECTION OF A LICENSED PROFESSIONAL ENGINEER, TO ALTER THIS DOCUMENT

SCAB013243  
 OAKLAND, CA 94602  
 (E) 26'-0" STEEL LIGHT POLE

SHEET TITLE  
**PLUMBING & RISER DIAGRAM**

SHEET NUMBER  
**PL-1**

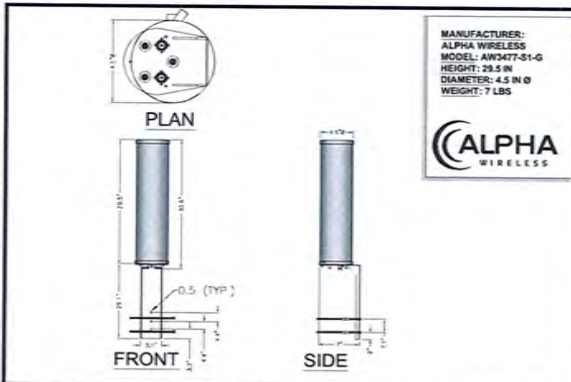

**ALPHA AW3477-S1-G OMNI (B41)** SCALE N.T.S. 1

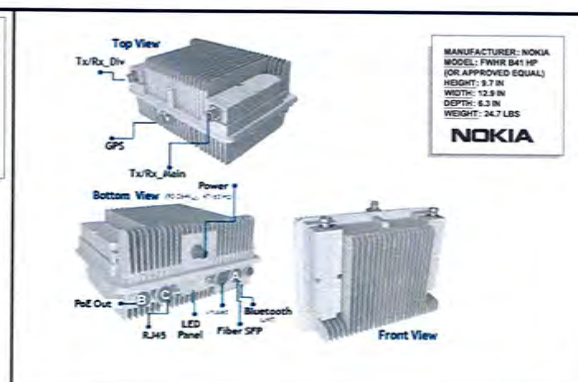

**NOKIA RADIO FWHR B41 HP** SCALE N.T.S. 4

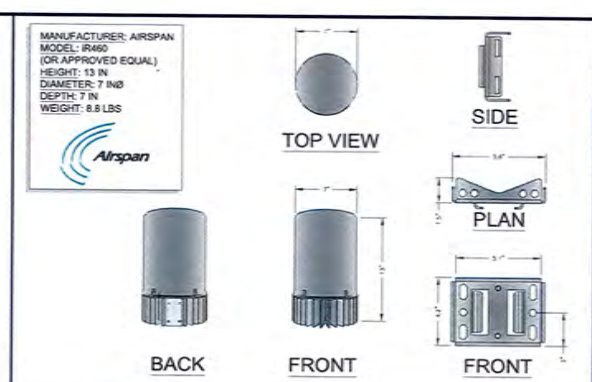

**iR460 UE RELAY/FLUSH MOUNT** SCALE N.T.S. 6

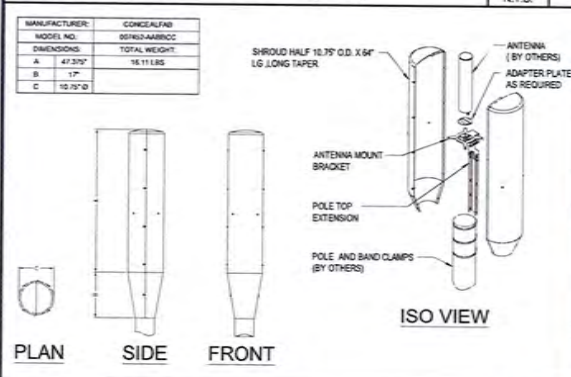

**ANTENNA SHROUD** SCALE N.T.S. 2

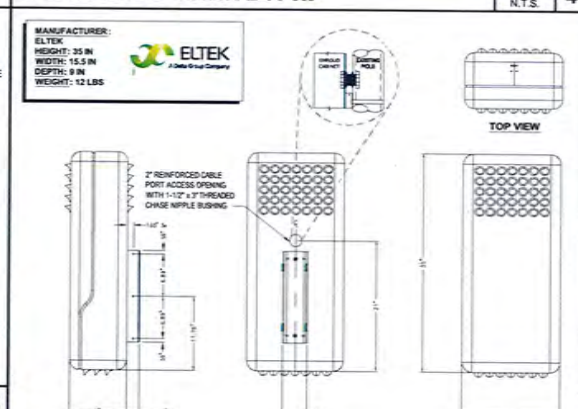

**(MMS) SHROUD ENCLOSURE** SCALE N.T.S. 5

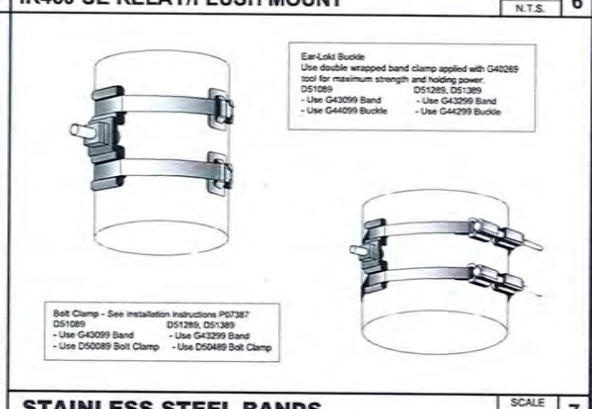

**STAINLESS STEEL BANDS** SCALE N.T.S. 7

**NOTICE**

Radio frequency fields beyond this point may exceed the FCC general public exposure limit.

Site ID: SCAB013243  
 Contact: 877-244-7889  
**mobilitie**

RF WARNING SIGN WILL BE PAINTED TO MATCH EXISTING POLE.  
 SIGN TO BE NO LARGER THAN 3'X 4'.  
 SIGN TO BE MOUNTED ON CURB SIDE.

**ANTENNA RF SIGNAGE**

**SHUT DOWN PROCEDURE SIGN**

**EMERGENCY NUMBER AND OTHER SIGNAGE:**  
 1. THE SIGN SHOULD BE PLACED AT THE FOLLOWING LOCATIONS:  
 - CURB SIDE OF THE POLE  
 - SIDE OF THE POLE  
 - SIDE OF THE POLE  
 - SIDE OF THE POLE

**REMARKS:**  
 - SEE ALL OTHER SIGNAGE REQUIREMENTS FOR THIS PROJECT  
 - SIGN SHOULD BE PLACED AT THE FOLLOWING LOCATIONS:  
 - CURB SIDE OF THE POLE  
 - SIDE OF THE POLE  
 - SIDE OF THE POLE  
 - SIDE OF THE POLE

**POLE MOUNTED SIGNS** SCALE N.T.S. 3

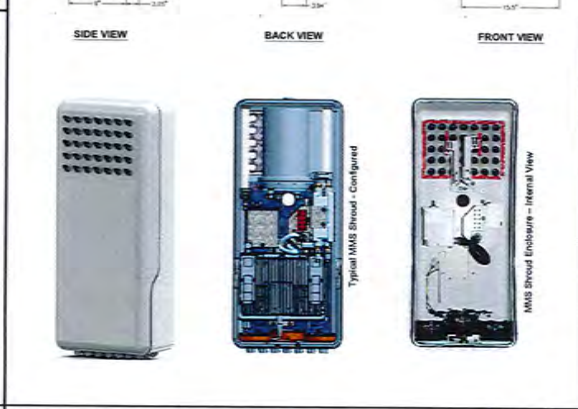

**(MMS) SHROUD ENCLOSURE** SCALE N.T.S. 5

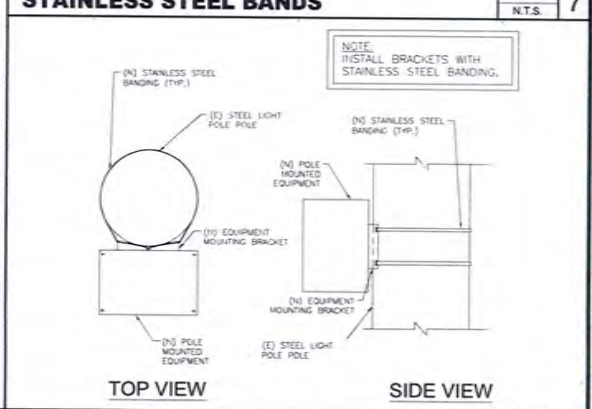

**EQUIPMENT MOUNTING DETAIL** SCALE N.T.S. 8

**mobilitie**  
 intelligent infrastructure

**C&S** cable engineering services  
 PRESCOTT COMMUNICATIONS, INC.  
 10640 Sepulveda Blvd. Suite 1, Mission Hills, CA 91345  
 Phone No. (818) 250-2252 Fax No. (818) 250-4188

PROJECT NO:	SCAB013243
DRAWN BY:	MO
CHECKED BY:	JM

1	05/26/17	ISSUE CONSTRUCTION
1	05/21/17	ADDED SMART METER
2	08/29/17	REVISED PER PG&E STANDARDS

IT IS A VIOLATION OF THE LAW FOR ANY PERSON, UNLESS THEY ARE ACTING UNDER THE DIRECTION OF A LICENSED PROFESSIONAL ENGINEER, TO ALTER THIS DOCUMENT.

9CAB013243  
 OAKLAND, CA 94602  
 (E) 26'-0" STEEL LIGHT POLE

SHEET TITLE  
**EQUIPMENT DETAILS**

SHEET NUMBER  
**EQ-1**





SECTION A-A

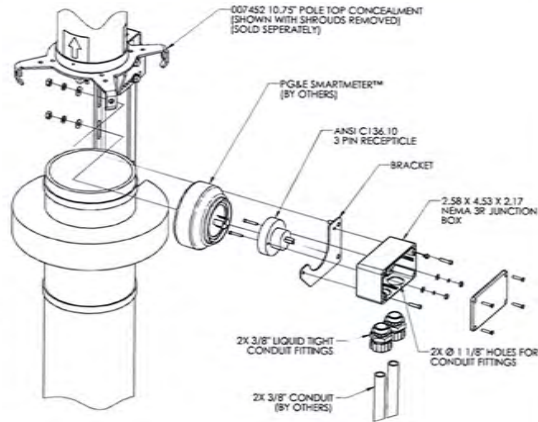
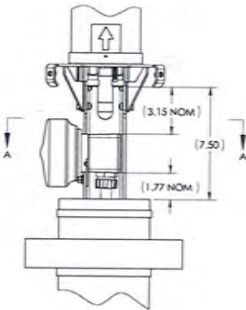

PG&E SMART METER

SCALE  
N.T.S. 1

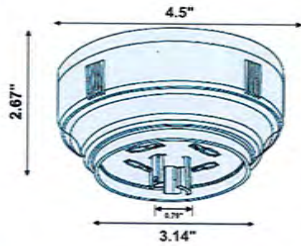

- UNIVERSAL AC INPUT 90V-300V, 50/60HZ
- AMPERE RATING: 15A MAX CONTINUOUS
- ADVANCED METERING INFRASTRUCTURE (AMI) NETWORK COMMUNICATION CARD TO REMOTELY SEND ENERGY USAGE BACK TO THE HEAD-END SYSTEM.
- DATE RATE: 50 TO 300 KBPS
- FREQUENCY RANGE: 902-928 MHz
- SPREAD SPECTRUM: FREQUENCY HOPPING
- TRANSMITTER OUTPUT: 27-30 DBM (1W)
- RECEIVER SENSITIVITY: -98 DBM FOR 10% PER
- PROTOCOL: IEEE 802.15.4G



PG&E SMART METER

SCALE  
N.T.S. 2

NEMA 3R JUNCTION BOX

SCALE  
N.T.S. 3

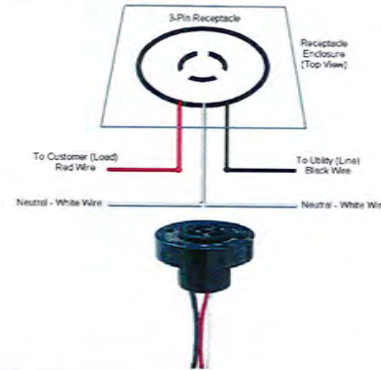

DIMMING RECEPTACLE

SCALE  
N.T.S. 4

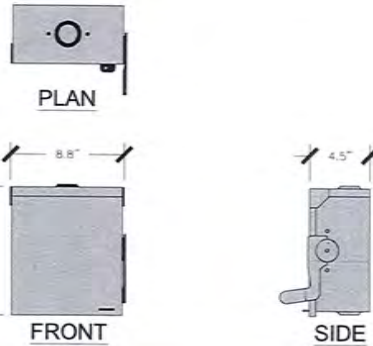

MANUFACTURER:  
SIEMENS  
MODEL: GNF321R  
(OR APPROVED EQUAL)  
HEIGHT: 9.9 IN  
WIDTH: 8.8 IN  
DEPTH: 4.5 IN  
WEIGHT: 5 LBS  
**SIEMENS**

SEE DETAIL



NEMA-3R DISCONNECT SWITCH

SCALE  
N.T.S. 5

MANUFACTURER:  
ALLEN-BRADLEY  
MODEL: 598-BSS33  
HEIGHT: 4.53 IN  
WIDTH: 2.58 IN  
DEPTH: 2.17 IN  
WEIGHT: TBD  
**Rockwell Automation**  
Allen-Bradley



**mobilitie**  
intelligent infrastructure

**C&S** cable engineering services  
PRESCOTT COMMUNICATIONS, INC.  
10640 Sepulveda Blvd, Suite 1, Mission Hills, CA 91345  
Phone No.: (818)928-2332 Fax No.: (818)928-8188

PROJECT NO: 9CAB013243  
DRAWN BY: MD  
CHECKED BY: JM

0	02/26/17	ISS CONSTRUCTION
1	05/21/17	ADDED SMART METER
3	09/28/17	REVISED PER PG&E STANDARDS

IT IS A VIOLATION OF THE LAW FOR ANY PERSON, UNLESS THEY ARE ACTING UNDER THE DIRECTION OF A LICENSED PROFESSIONAL ENGINEER, TO ALTER THIS DOCUMENT

9CAB013243  
OAKLAND, CA 94602  
(E) 26'-0" STEEL LIGHT POLE

SHEET TITLE  
EQUIPMENT DETAILS

SHEET NUMBER  
EQ-2

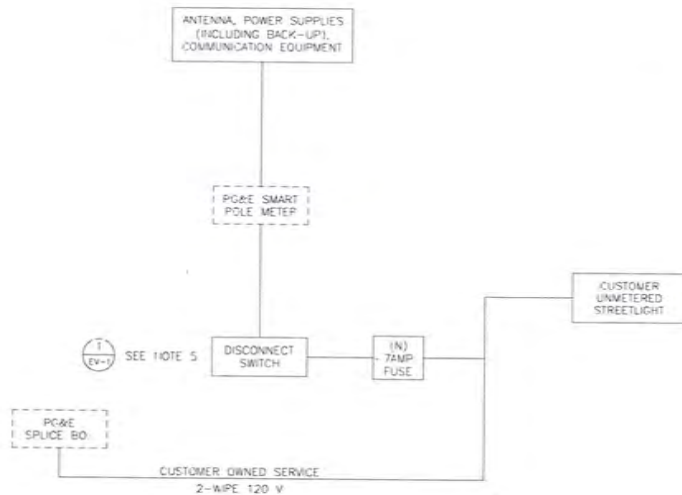

### ONE-LINE DIAGRAM

SCALE: NOT TO SCALE

1

### NOKIA MM RADIO W/ UE RELAY

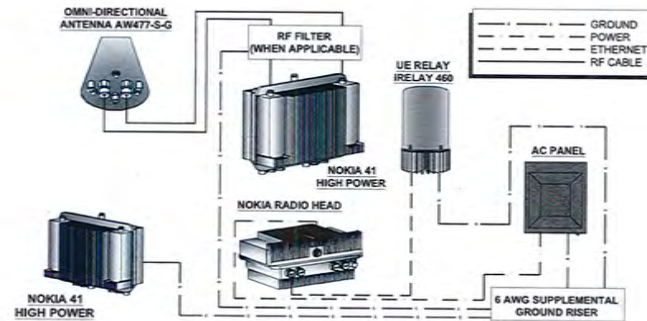

### WIRING DIAGRAM

SCALE: NOT TO SCALE

2

#### NOTES:

1. NOMINAL POWER IS CALCULATED AS 80% OF OEM DOCUMENTED MAXIMUM POWER.
2. CALCULATIONS FOR UE W/ NOKIA DO NOT NEED TO INCLUDE THE POWER FOR THE UE ANTENNA AS IT IS INCLUDED IN THE MAX POWER FIGURE. CALCULATIONS FOR UE W/ AIRSPAN MUST INCLUDE UE AS IT IS NOT INCLUDED.
3. KVA IS CALCULATED FROM THE CONSUMPTION VALUE ASSUMING A PF=1. MAXIMUM POWER WAS USED FOR KVA. WHERE MAXIMUM WAS NOTED BY THE OEM THE QUOTED FIGURE WAS USED. WHERE AVERAGE/NOMINAL POWER WAS NOTED BY THE OEM MAXIMUM POWER WAS CALCULATED BY INCREASING AVERAGE/NOMINAL POWER BY A FACTOR OF 50%.
4. COST PER KW PROVIDED BY BRAHII KOGYMAN.

NOKIA SCENARIO 3 B41 HIGH POWER RADIO AND UE BACKHAUL									
UNIT	SUB DESCRIPTION	MAX POWER	NOMINAL POWER	AVERAGE POWER (W)	CONV.	KVA	kWh/YR	\$/YR	\$/MO
FWHR	B41 High	360	288	N/A	288	0.36	2522.88	\$276.51	\$23.04
AIRSPAN UE RELAY	IR460-3PB-ST1-P-0	11/2	N/A	N/A	0	0	0	\$-	\$-
TOTAL					288	0.36	2522.88	\$276.51	\$23.04

### LOAD CALCULATIONS

SCALE: NOT TO SCALE

3

**mobilitie**  
intelligent infrastructure

**C&S** cable engineering services

PRESCOTT COMMUNICATIONS, INC.  
10540 Sepulveda Blvd, Suite 1, Mission Hills, CA 91345  
Phone No.: (818)201-2352 Fax No.: (818)201-0166

PROJECT NO: 9CAB013243

DRAWN BY: MD

CHECKED BY: JM

0 05/26/17 SOK CONSTRUCTION

1 05/29/17 ADDED SMART METER

2 09/26/17 REVISED PER PDME STANDARDS

9CAB013243

OAKLAND, CA 94602

(E) 26'-0" STEEL LIGHT POLE

SHEET TITLE  
ELECTRICAL DETAILS

SHEET NUMBER  
E-1

NOTE:  
CONTRACTOR TO SURROUND COMPLETED CONNECTION WITH HEAT-SHRINK TUBING TO ENSURE WEATHER PROOF CONNECTION

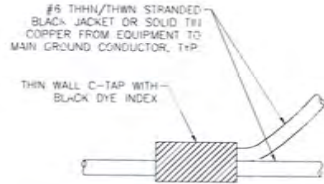

**C-TAP DETAIL**

SCALE: NOT TO SCALE

1

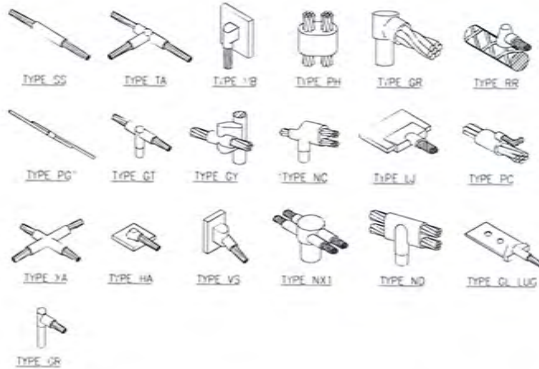

- GROUNDING BONDS:** ALL BONDS ARE TO BE MADE WITH #2 AWG STRANDED COPPER IN GREEN INSULATION. (ATT-TP-76416 7, 6.7)
- EXTERIOR UNIT BONDS:** ALL METALLIC OBJECTS SHALL BE BONDED TO THE GROUND ROD. (ATT-TP-76416 7, 12.6)
- GROUND ROD:** UL LISTED COPPER CLAD STEEL GROUND ROD WITH MINIMUM DIAMETER OF 5/8" AND MINIMUM LENGTH OF 8 FEET. ALL GROUND RODS MAY BE INSTALLED WITH INSPECTION SLEEVES. GROUND RODS SHALL BE DRIVEN TO A MINIMUM DEPTH OF 30" BELOW GRADE OR 6 INCHES BELOW FROST LINE. (ATT-TP-76416 1.4 / 2.2, 3, 10)

**WELD CONNECTION DETAILS**

SCALE: NOT TO SCALE

2

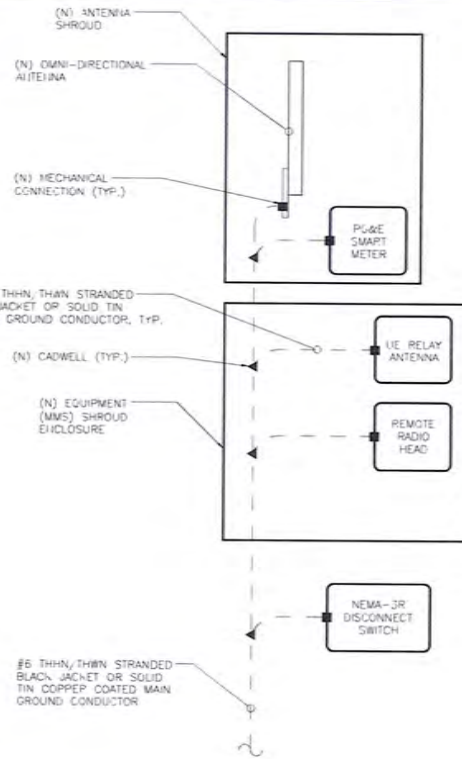

#6 THHN/THWN STRANDED BLACK JACKET OR SOLID TIN COPPER COATED MAIN GROUND CONDUCTOR

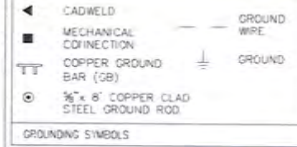
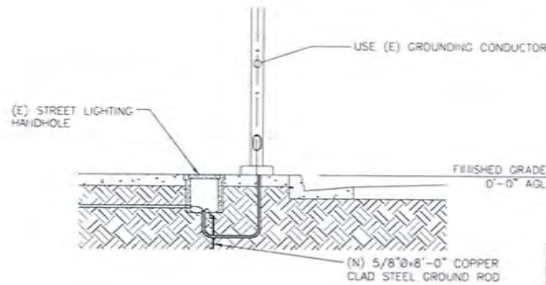

- NOTES:
- GROUNDING RISER FOR DIAGRAMMATIC PURPOSES ONLY. SEE ELEVATION DRAWING FOR EQUIPMENT AND ANTENNA LOCATIONS.
  - ALL RODS TO BE GROUNDING AT BOTH ENDS USING GROUNDING BUSHINGS.
  - GROUND WIRE BELOW 11' AGL TO BE RUN IN 1/2" SCHEDULE 40 PVC

**GROUNDING RISER DIAGRAM**

SCALE: NOT TO SCALE

3

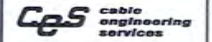

PRESCOTT COMMUNICATIONS, INC.  
10640 Sequoia Blvd, Suite 1, Mission Hills, CA 91345  
Phone No.: (818)958-2352 Fax No.: (818)958-9186

PROJECT NO: SCAB013243  
DRAWN BY: MD  
CHECKED BY: JM

0	05/25/17	ISS CONSTRUCTION
1	12/21/17	ADDED SMART METER
2	09/29/17	REVISED PER POLE STANDARDS

IT IS THE POLICY OF THE FIRM FOR ALL PERSONS UNLESS THEY ARE ACTING UNDER THE DIRECTION OF A LICENSED PROFESSIONAL ENGINEER, TO ALTER THIS DOCUMENT

SCAB013243  
OAKLAND, CA 94602  
(E) 26'-0" STEEL LIGHT POLE

SHEET TITLE  
GROUNDING DETAILS

SHEET NUMBER  
G-1



**GENERAL CONSTRUCTION NOTES:**

1. ALL WORK SHALL CONFORM TO THE REQUIREMENTS OF THE LOCAL BUILDING CODE, THE LATEST ADOPTED EDITION AND ALL OTHER APPLICABLE CODES AND ORDINANCES.
2. CONTRACTOR SHALL CONSTRUCT SITE IN ACCORDANCE WITH THESE DRAWINGS AND LATEST MOBILITE CONSTRUCTION STANDARDS. THE SPECIFICATION IS THE RULING DOCUMENT AND ANY DISCREPANCIES BETWEEN THE SPECIFICATION AND THE CONSTRUCTION DRAWINGS SHALL BE BROUGHT TO THE ATTENTION OF THE ARCHITECT/ENGINEER OF MOBILITE CM PRIOR TO THE COMMENCEMENT OF WORK.
3. CONTRACTOR SHALL VISIT THE JOB SITE AND SHALL FAMILIARIZE THEMSELVES WITH ALL CONDITIONS AFFECTING THE (N) WORK AND SHALL MAKE PROVISIONS AS TO THE COST THEREOF. CONTRACTOR SHALL BE RESPONSIBLE FOR FAMILIARIZING THEMSELVES WITH ALL CONTRACT DOCUMENTS, FIELD CONDITIONS AND DIMENSIONS AND CONFIRMING THAT THE WORK MAY BE ACCOMPLISHED, AS SHOWN, PRIOR TO PROCEEDING WITH CONSTRUCTION. ANY DISCREPANCIES SHALL BE BROUGHT TO THE ATTENTION OF THE ARCHITECT/ENGINEER OF MOBILITE CM PRIOR TO THE COMMENCEMENT OF WORK. NO COMPENSATION WILL BE AWARDED BASED ON CLAIM OF LACK OF KNOWLEDGE OF FIELD CONDITIONS.
4. IT IS NOT THE INTENT OF THESE PLANS TO SHOW EVERY MINOR DETAIL OF CONSTRUCTION. CONTRACTOR IS REQUIRED TO FURNISH AND INSTALL ANY/ALL ITEMS FOR A COMPLETE AND FULLY FUNCTIONAL SYSTEM SUBJECT ONLY TO OWNER-SUPPLIED ITEMS. CONTRACTOR SHALL PROVIDE ANY/ALL REQUIREMENTS FOR THE EQUIPMENT TO BE PLACED IN PROPER WORKING ORDER.
5. PLANS ARE NOT TO BE SCALED. THESE PLANS ARE INTENDED TO BE A DIMENSIONAL OUTLINE ONLY UNLESS OTHERWISE NOTED. THE WORK SHALL INCLUDE FURNISHING MATERIALS, EQUIPMENT AND APPURTENANCES, AND LABOR NECESSARY TO EFFECT ALL INSTALLATIONS AS INDICATED ON THE DRAWINGS. OWNER PROVIDED MATERIALS WILL INCLUDE THOSE ITEMS LISTED IN THE EQUIPMENT DETAILS SECTION OF THESE DRAWINGS UNLESS OTHERWISE SPECIFIED OR PROVIDED TO THE CONTRACTOR IN WRITING PRIOR TO CONSTRUCTION START.
6. DIMENSIONS SHOWN ARE TO FINISH SURFACES UNLESS OTHERWISE NOTED. SPACING BETWEEN EQUIPMENT IS REQUIRED CLEARANCE. THEREFORE, IT IS CRITICAL TO FIELD VERIFY DIMENSIONS. SHOULD THERE BE ANY QUESTIONS REGARDING THE CONTRACT DOCUMENTS, (E) CONDITIONS AND/OR DESIGN INTENT, THE CONTRACTOR SHALL BE RESPONSIBLE FOR REPORTING ANY DISCREPANCIES TO THE ATTENTION OF THE MOBILITE CM, IN WRITING, PRIOR TO THE COMMENCEMENT OF WORK.
7. DETAILS PROVIDED ARE FOR THE PURPOSE OF SHOWING DESIGN INTENT. MODIFICATIONS MAY BE REQUIRED TO SUIT JOB DIMENSIONS OR SITE CONDITIONS. AND SUCH MODIFICATIONS SHALL BE INCLUDED AS PART OF THE WORK.
8. CONTRACTOR SHALL PAY FOR APPLICABLE PERMITS, FEES, INSPECTIONS AND TESTING. CONTRACTOR IS TO OBTAIN PERMITS AND APPROVED SUBMITTALS PRIOR TO ORDERING MATERIALS AND THE COMMENCEMENT OF WORK.
9. THE TERM "PROVIDE" USED IN CONSTRUCTION DOCUMENTS AND SPECIFICATIONS, INDICATES THAT THE CONTRACTOR SHALL FURNISH AND INSTALL.
10. CONTRACTOR SHALL RECEIVE CLARIFICATION IN WRITING, AND SHALL RECEIVE IN WRITING AUTHORIZATION TO PROCEED BEFORE STARTING WORK ON ANY ITEMS NOT CLEARLY DEFINED OR IDENTIFIED BY THE CONTRACT DOCUMENTS.
11. CONTRACTOR SHALL SUPERVISE AND DIRECT THE WORK USING ACCEPTED INDUSTRY-STANDARD SKILLS AND ATTENTION. CONTRACTOR SHALL BE SOLELY RESPONSIBLE FOR CONSTRUCTION MEANS, METHODS, TECHNIQUES, SEQUENCES AND PROCEDURES AND FOR COORDINATING ALL PORTIONS OF THE WORK UNDER CONTRACT, UNLESS OTHERWISE NOTED.
12. CONTRACTOR SHALL BE RESPONSIBLE FOR THE SAFETY OF THE WORK AREA, ADJACENT AREAS AND BUILDING OCCUPANTS THAT ARE LIKELY TO BE AFFECTED BY THE WORK UNDER THIS CONTRACT. WORK SHALL CONFORM TO ALL OSHA REQUIREMENTS.
13. CONTRACTOR SHALL COORDINATE THEIR WORK WITH THE MOBILITE CM AND SCHEDULE THEIR ACTIVITIES AND WORKING HOURS IN ACCORDANCE WITH THE REQUIREMENTS.

14. CONTRACTOR SHALL BE RESPONSIBLE FOR COORDINATING THEIR WORK WITH THE WORK OF OTHERS AS IT MAY RELATE TO RADIO EQUIPMENT, ANTENNAS AND ANY OTHER PORTIONS OF THE WORK.
15. CONTRACTOR SHALL INSTALL ALL EQUIPMENT AND MATERIALS IN ACCORDANCE WITH MANUFACTURERS RECOMMENDATIONS UNLESS SPECIFICALLY OTHERWISE INDICATED OR WHERE LOCAL CODES OR REGULATIONS TAKE PRECEDENCE.
16. CONTRACTOR SHALL MAKE NECESSARY PROVISIONS TO PROTECT (E) SURFACES, EQUIPMENT, IMPROVEMENTS, PIPING ETC AND IMMEDIATE REPAIR TO NEW CONDITION. ANY DAMAGE THAT OCCURS DURING CONSTRUCTION AT THE SOLE COST OF THE CONTRACTOR.
17. IN DRILLING HOLES, OR COPING, INTO CONCRETE WHETHER FOR FASTENING OR ANCHORING PURPOSES, OR PENETRATIONS THROUGH THE FLOOR FOR CONDUIT RUNS, PIPE RUNS, ETC. MUST BE CLEARLY UNDERSTOOD THAT REINFORCING STEEL SHALL NOT BE DRILLED INTO, CUT OR DAMAGED UNDER ANY CIRCUMSTANCES (UNLESS NOTED OTHERWISE). LOCATIONS OF REINFORCING STEEL ARE NOT DEFINITELY KNOWN AND THEREFORE MUST BE LOCATED BY THE CONTRACTOR USING APPROPRIATE METHODS AND EQUIPMENT PRIOR TO ANY DRILLING OR CORING OPERATIONS IN (E) CONCRETE.
18. CONTRACTOR SHALL REPAIR, TO NEW CONDITION, ALL (E) WALL SURFACES DAMAGED DURING CONSTRUCTION SUCH THAT THEY MATCH AND BLEND IN WITH ADJACENT SURFACES.
19. CONTRACTOR SHALL SEAL PENETRATIONS THROUGH FIRE RATED ASSEMBLIES OR MATERIALS WITH ULL LISTED AND FIRE CODE APPROVED MATERIALS AND SYSTEMS THAT MEET OR EXCEED THE RATING OF THE ASSEMBLY IN WHICH THE NEW PENETRATION IS PLACED.
20. CONTRACTOR SHALL KEEP CONTRACT AREA CLEAN, HAZARD FREE, AND DISPOSE OF ALL DIRT, DEBRIS, AND RUBBISH. EQUIPMENT NOT SPECIFIED AS REMAINING ON THE PROPERTY OF THE OWNER SHALL BE REMOVED. LEAVE PREMISES IN CLEAN CONDITION AND FREE FROM PAINT SPOTS, DUST, OR SMUDGES OF ANY NATURE. CONTRACTOR SHALL BE RESPONSIBLE FOR MAINTAINING ALL ITEMS UNTIL COMPLETION OF CONSTRUCTION.
21. MINIMUM BEND RADIUS OF ANTENNA CABLES SHALL BE IN ACCORDANCE WITH CABLE MANUFACTURERS RECOMMENDATIONS.
22. CONTRACTOR SHALL MINIMIZE DISTURBANCE TO (E) SITE DURING CONSTRUCTION. EROSION CONTROL MEASURES, IF REQUIRED DURING CONSTRUCTION SHALL BE IN CONFORMANCE WITH JURISDICTIONAL OR STATE AND LOCAL GUIDELINES FOR EROSION AND SEDIMENT CONTROL, AND COORDINATED WITH LOCAL REGULATORY AUTHORITIES. CONTRACTOR SHALL BE RESPONSIBLE FOR MAINTENANCE OF ANY EROSION CONTROL MEASURES, RECORD-KEEPING, MONITORING, AND REPORTING TO THE OWNER AND REGULATORY AUTHORITIES.
23. ALL CONSTRUCTION WORK IS TO ADHERE TO APPLICANT'S INTEGRATED CONSTRUCTION STANDARDS UNLESS STATE OR LOCAL CODE IS MORE STRINGENT.
24. THE INTENT OF THE PLANS AND SPECIFICATIONS IS TO PERFORM THE CONSTRUCTION IN ACCORDANCE PER STATE BUILDING STANDARDS CODE AND STATE CODE OF REGULATIONS SHOULD ANY CONDITIONS DEVELOP NOT COVERED BY THE APPROVED PLANS AND SPECIFICATIONS WHEREIN THE FINISHED WORK WILL NOT COMPLY PER STATE CODE OF REGULATIONS, A SCOPE OF WORK DETAILING AND SPECIFYING THE REQUIRED WORK SHALL BE SUBMITTED TO AND APPROVED BY THE JURISDICTION BEFORE PROCEEDING WITH THE WORK. A CHANGE ORDER FOR THAT SCOPE SHALL BE SUBMITTED TO THE MOBILITE CM PRIOR TO PROCEEDING WITH THE WORK.
25. ADEQUATE AND REQUIRED LIABILITY INSURANCE SHALL BE PROVIDED BY THE CONTRACTOR FOR PROTECTION AGAINST PUBLIC LOSS AND ANY/ALL PROPERTY DAMAGE FOR THE DURATION OF WORK.
26. CONTRACTOR SHALL GUARANTEE ANY/ALL MATERIALS AND WORK FREE FROM DEFECTS FOR A PERIOD OF NOT LESS THAN ONE YEAR FROM DATE OF ACCEPTANCE. ANY CORRECTIVE WORK SHALL BE COMPLETED AT THE SOLE COST OF THE CONTRACTOR.
27. CONTRACTOR TO TAP IN AT THE POC AND RUN A NEW, SEPARATE CIRCUIT THROUGH CITY CONDUIT TO GO TO THE POLE.

**ELECTRICAL NOTES:**

1. ELECTRICAL CONTRACTOR SHALL SUPPLY AND INSTALL ANY/ALL ELECTRICAL WORK INDICATED ANY/ALL CONSTRUCTION SHALL BE IN ACCORDANCE WITH DRAWINGS AND ANY/ALL APPLICABLE SPECIFICATIONS. IF ANY PROBLEMS ARE ENCOUNTERED BY COMPLYING WITH THESE REQUIREMENTS, CONTRACTOR SHALL NOTIFY MOBILITE CM AS SOON AS POSSIBLE, AFTER THE DISCOVERY OF THE PROBLEMS, AND SHALL NOT PROCEED WITH THAT PORTION OF WORK, UNTIL THE MOBILITE CM HAS DIRECTED THE CORRECTIVE ACTIONS TO BE TAKEN.
2. ELECTRICAL CONTRACTOR SHALL VISIT THE JOB SITE AND FAMILIARIZE THEMSELVES WITH ANY/ALL CONDITIONS AFFECTING ELECTRICAL AND COMMUNICATION INSTALLATION AND MAKE PROVISIONS AS TO THE COST THEREOF. ALL (E) CONDITIONS OF ELECTRICAL EQUIP., ETC., THAT ARE PART OF THE FINAL SYSTEM, SHALL BE VERIFIED BY THE CONTRACTOR, PRIOR TO THE SUBMITTING OF THEIR BID. FAILURE TO COMPLY WITH THIS PARAGRAPH WILL IN NO WAY RELIEVE CONTRACTOR OF PERFORMING ALL WORK NECESSARY FOR A COMPLETE AND WORKING SYSTEM.
3. ALL WORK SHALL BE PERFORMED IN ACCORDANCE WITH THE LATEST EDITION OF THE NEC, ALL CODES AND ORDINANCES OF THE LOCAL JURISDICTION, AND POWER & TELEPHONE COMPANIES HAVING JURISDICTION AND SHALL INCLUDE BUT ARE NOT BE LIMITED TO:
  - A) UL - UNDERWRITERS LABORATORIES
  - B) NEC - NATIONAL ELECTRICAL CODE
  - C) NEMA - NATIONAL ELECTRICAL MANUFACTURERS ASSOC.
  - D) OSHA - OCCUPATIONAL SAFETY AND HEALTH ACT
  - E) SBC - STANDARD BUILDING CODE
  - F) NFPA - NATIONAL FIRE PROTECTION AGENCY
  - G) ANSI - AMERICAN NATIONAL STANDARDS INSTITUTE
  - H) IEEE - INSTITUTE OF ELECTRICAL AND ELECTRONICS ENGINEERS
  - I) ASTM - AMERICAN SOCIETY FOR TESTING MATERIALS
4. REFER TO SITE PLANS AND ELEVATIONS FOR EXACT LOCATIONS OF ALL EQUIPMENT, AND CONFIRM WITH MOBILITE CM ANY SIZES AND LOCATIONS WHEN NEEDED.
5. (E) SERVICES: CONTRACTOR SHALL NOT INTERRUPT (E) SERVICES WITHOUT WRITTEN PERMISSION OF THE OWNER.
6. CONTRACTOR SHALL CONFIRM WITH LOCAL UTILITY COMPANY ANY/ALL REQUIREMENTS SUCH AS THE LUG SIZE RESTRICTIONS, CONDUIT ENTRY, SIZE OF TRANSFORMERS, SCHEDULED DOWNTIME FOR THE OWNERS' CONFIRMATION, ETC., ANY/ALL CONFLICTS SHALL BE BROUGHT TO THE ATTENTION OF THE MOBILITE CM, PRIOR TO BEGINNING ANY WORK.
7. MINIMUM WIRE SIZE SHALL BE #12 AWG, NOT INCLUDING CONTROL WIRING, UNLESS NOTED OTHERWISE. ALL CONDUCTORS SHALL BE COPPER WITH THWN INSULATION, UNLESS OTHERWISE NOTED.
8. OUTLET BOXES SHALL BE PRESSED STEEL IN DRY LOCATIONS, CAST ALLOY WITH THREADED HUBS IN WET/DAMP LOCATIONS AND SPECIAL ENCLOSURES FOR OTHER CLASSIFIED AREAS.
9. IT IS NOT THE INTENT OF THESE PLANS TO SHOW EVERY MINOR DETAIL OF THE CONSTRUCTION. CONTRACTOR IS EXPECTED TO FURNISH AND INSTALL ALL ITEMS FOR A COMPLETE ELECTRICAL SYSTEM AND PROVIDE ALL REQUIREMENTS FOR THE EQUIPMENT TO BE PLACED IN PROPER WORKING ORDER.
10. ELECTRICAL SYSTEM SHALL BE AS COMPLETELY AND EFFECTIVELY GROUNDED, AS REQUIRED BY SPECIFICATIONS, SET FORTH BY APPLICANT.
11. ALL WORK SHALL BE PERFORMED BY A LICENSED ELECTRICAL CONTRACTOR IN A FIRST CLASS, WORKMANLIKE MANNER. THE COMPLETED SYSTEM SHALL BE FULLY FUNCTIONAL AND SHALL BE APPROVED BY THE MOBILITE CM AND LOCAL JURISDICTION. ANY DEFICIENCIES SHALL BE CORRECTED BY AN ELECTRICAL CONTRACTOR AT THE SOLE COST OF THE CONTRACTOR.
12. ALL WORK SHALL BE COORDINATED WITH OTHER TRADES TO AVOID INTERFERENCE WITH THE PROGRESS OF CONSTRUCTION.

**mobilitie**  
intelligent infrastructure

**CPS** cable engineering services

PRESCOTT COMMUNICATIONS, INC.  
10640 Sepulveda Blvd. Suite 1, Mission Hills, CA 91345  
Phone No. (818)950-2252 Fax No. (818)950-0108

PROJECT NO: 9CAB013243  
DRAWN BY: MD  
CHECKED BY: JM

NO.	DATE	DESCRIPTION
1	05/05/17	REV. CONSTRUCTION
1	05/21/17	ADDED DRAFT W/ITER
2	09/26/17	REVISED PER PS&E STANDARDS

IT IS A VIOLATION OF THE LAW FOR ANY PERSON, UNLESS THEY ARE ACTING UNDER THE DIRECTION OF A LICENSED PROFESSIONAL ENGINEER, TO ALTER THIS DOCUMENT.

9CAB013243  
OAKLAND, CA 94602  
(E) 26'-0" STEEL LIGHT POLE

SHEET TITLE  
GENERAL NOTES

SHEET NUMBER  
GN-1



**ELECTRICAL NOTES CONT'D**

15. THE CORRECTION OF ANY DEFECTS SHALL BE COMPLETED BY THE CONTRACTOR WITHOUT ANY ADDITIONAL CHARGE AND SHALL INCLUDE THE REPLACEMENT OR THE REPAIR OF ANY OTHER PHASE OF THE INSTALLATION, WHICH MAY HAVE BEEN DAMAGED THEREIN.
16. CONTRACTOR SHALL PROVIDE AND INSTALL CONDUIT, CONDUCTORS, PULL WIRES, BOXES, COVER PLATES AND DEVICES FOR ALL OUTLETS AS INDICATED.
17. DITCHING AND BACK FILL: CONTRACTOR SHALL PROVIDE FOR ALL UNDERGROUND INSTALLED CONDUIT AND/OR CABLES INCLUDING EXCAVATION AND BACKFILLING AND COMPACTION. REFER TO NOTES AND REQUIREMENTS EXCAVATION, AND BACKFILLING.
18. MATERIALS, PRODUCTS AND EQUIPMENT INCLUDING ALL COMPONENTS THEREOF SHALL BE NEW AND SHALL APPEAR ON THE LIST OF U.L. APPROVED ITEMS AND SHALL MEET OR EXCEED THE REQUIREMENTS OF THE NEC, NEMA AND IEC.
19. CONTRACTOR SHALL SUBMIT SHOP DRAWINGS OR MANUFACTURER'S CATALOG INFORMATION OF ANY/ALL EQUIPMENT AND ALL OTHER ELECTRICAL ITEMS FOR APPROVAL BY THE MOBILITE CM PRIOR TO INSTALLATION.
20. ANY CUTTING OR PATCHING DEEMED NECESSARY FOR ELECTRICAL WORK IS THE ELECTRICAL CONTRACTOR'S RESPONSIBILITY AND SHALL BE INCLUDED IN THE COST FOR WORK AND PERFORMED TO THE SATISFACTION OF THE MOBILITE CM UPON FINAL ACCEPTANCE.
21. THE ELECTRICAL CONTRACTOR SHALL LABEL ALL PANELS WITH ONLY TYPEWRITTEN DIRECTORIES. ALL ELECTRICAL WIRING SHALL BE THE RESPONSIBILITY OF THE ELECTRICAL CONTRACTOR.
22. DISCONNECT SWITCHES SHALL BE UL-RATED, H.P. RATED HEAVY-DUTY, QUICK-MAKE AND QUICK-BREAK ENCLOSURES, AS REQUIRED BY EXPOSURE TYPE.
23. ALL CONNECTIONS SHALL BE MADE WITH A PROTECTIVE COATING OF AN ANTI-OXIDE COMPOUND KNOWN AS "NO-OXIDE" BY DEARBORNE CHEMICAL CO. COAT ALL WIRE SURFACES BEFORE CONNECTING EXPOSED COPPER SURFACES, INCLUDING GROUND BARS, SHALL BE TREATED - NO SUBSTITUTIONS.
24. RACEWAYS: CONDUIT SHALL BE SCHEDULE 80 PVC MEETING OR EXCEEDING NEMA TC2 - 1990. CONTRACTOR SHALL PLUG AND CAP EACH END OF SPARE AND EMPTY CONDUITS AND PROVIDE TWO SEPARATE PULL STRINGS - 200 LBS TEST POLYETHYLENE CORD. ALL CONDUIT BENDS SHALL BE A MINIMUM OF 2 FT. RADIUS. RGS CONDUITS WHEN SPECIFIED SHALL MEET UL-6 FOR GALVANIZED STEEL. ALL FITTINGS SHALL BE SUITABLE FOR USE WITH THREADED RIGID CONDUIT. COAT ALL THREADS WITH "BRITE ZINC" OR "COLD GALV."
25. SUPPORT OF ALL ELECTRICAL WORK SHALL BE AS REQUIRED BY NEC.
26. CONDUCTORS: CONTRACTOR SHALL USE 99% CONDUCTIVITY COPPER WITH TYPE THIN INSULATION, UNLESS OTHERWISE NOTED. 600 VOLT, COLOR CODED, USE SOLID CONDUCTORS FOR WIRE UP TO AND INCLUDING NO. 8 AWG AND STRANDED CONDUCTORS FOR WIRE ABOVE NO. 8 AWG.
27. CONNECTORS FOR POWER CONDUCTORS: CONTRACTOR SHALL USE PRESSURE TYPE INSULATED TWIST-ON CONNECTORS FOR NO. 10 AWG AND SMALLER, USE SOLDERLESS MECHANICAL TERMINAL LUGS FOR NO. 8 AWG AND LARGER.
28. SERVICE: AS SPECIFIED ON THE DRAWINGS, OWNER OR OWNER'S AGENT WILL APPLY FOR POWER. ALL PROVISIONS FOR TEMPORARY POWER WILL BE OBTAINED BY THE CONTRACTOR.
29. TELEPHONE OR FIBER SERVICE: CONTRACTOR SHALL PROVIDE EMPTY CONDUITS WITH PULL STRINGS AS INDICATED ON DRAWINGS.
30. ELECTRICAL AND TELCO/FIBER RACEWAYS TO BE BURIED A MINIMUM DEPTH OF 30", UNLESS OTHERWISE NOTED.
31. CONTRACTOR SHALL PLACE 6" WIDE DETECTABLE WARNING TAPE AT A DEPTH OF 6" BELOW GROUND AND DIRECTLY ABOVE ELECTRICAL AND TELCO SERVICE CONDUITS, CAUTION TAPE TO READ "CAUTION BURIED ELECTRIC" OR "BURIED TELECOM".
32. ALL BOLTS SHALL BE 3-16 STAINLESS STEEL.
33. THE ELECTRICAL CONTRACTOR SHALL LABEL ALL PANELS WITH ONLY TYPEWRITTEN

DIRECTORIES. ALL ELECTRICAL WIRING SHALL BE THE RESPONSIBILITY OF THE ELECTRICAL CONTRACTOR.

**GROUNDING NOTES:**

1. ALL HARDWARE SHALL BE 3-16 STAINLESS STEEL, INCLUDING LOCK WASHERS. COAT ALL SURFACES WITH AN ANTI-OXIDANT COMPOUND, AS SPECIFIED, BEFORE MATING. ALL HARDWARE SHALL BE STAINLESS STEEL 3/8 INCH DIAMETER OR LARGER.
2. FOR GROUND BOND TO STEEL ONLY: INSERT A CADMIUM FLAT WASHER BETWEEN LUG AND STEEL. COAT ALL SURFACES WITH AN ANTI-OXIDANT COMPOUND BEFORE MATING.
3. ALL STEEL CONDUIT SHALL BE BONDED AT BOTH ENDS WITH GROUNDING BUSHING.
4. ALL ELECTRICAL AND GROUNDING AT THE POLE SITE SHALL COMPLY WITH THE NATIONAL ELECTRICAL CODE (NEC), NATIONAL FIRE PROTECTION ASSOCIATION (NFPA) 780 (LATEST EDITION), AND MANUFACTURER.
5. ALL DETAILS ARE SHOWN IN GENERAL TERMS. ACTUAL GROUNDING INSTALLATION AND CONSTRUCTION MAY VARY DUE TO SITE SPECIFIC CONDITIONS.
6. GROUND ALL ANTENNA BASES, FRAMES, CABLE FLUHS, AND OTHER METALLIC COMPONENTS USING #6 GROUND WIRES. FOLLOW ANTENNA AND BTS MANUFACTURER'S PRACTICES FOR GROUNDING REQUIREMENTS.
7. ALL GROUND CONNECTIONS SHALL BE #6 AWG, UNLESS OTHERWISE NOTED. ALL WIRES SHALL BE COPPER WITH THIN, UNLESS OTHERWISE NOTED. ALL GROUND WIRE SHALL BE SOLID TIN COATED OR STRANDED GREEN INSULATED WIRE.
8. CONTRACTOR TO VERIFY AND TEST GROUND TO SOURCE, 10 OHMS MAXIMUM. PROVIDE SUPPLEMENT GROUNDING RODS AS REQUIRED TO ACHIEVE SPECIFIED OHMS READING. GROUNDING AND OTHER OPTIONAL TESTING WILL BE WITNESSED BY THE MOBILITE CM.
9. NOTIFY ARCHITECT/ENGINEER IF THERE ARE ANY DIFFICULTIES INSTALLING GROUNDING SYSTEM DUE TO SITE SOIL CONDITIONS.
10. ALL HORIZONTALLY RUN GROUNDING CONDUCTORS SHALL BE INSTALLED A MINIMUM OF 30" BELOW GRADE, 6" BELOW FROST-LINE IF TRENCH, UNLESS OTHERWISE NOTED. BACK FILL SHALL BE COMPACTED AS REQUIRED BY ARCHITECT/ENGINEER.
11. ALL GROUND CONDUCTORS SHALL BE RUN AS STRAIGHT AND SHORT AS POSSIBLE, WITH A MINIMUM 12" BENDING RADIUS NOT LESS THAN 90 DEGREES.
12. ACCEPTABLE CONNECTIONS FOR GROUNDING SYSTEM SHALL BE:
  - A. BURNDY, HY-GRADE U.L. LISTED CONNECTORS FOR OUTDOOR USE OR AS APPROVED BY APPLICANT PROJECT MANAGER.
  - B. COLDWELD, EXOTHERMIC WELDS (WELDED CONNECTIONS).
  - C. ONE (1) HOLE TINNED COPPER COMPRESSION (LONG BARREL) FITTINGS.
13. ALL CRIMPED CONNECTIONS SHALL HAVE EMBOSSED MANUFACTURER'S DEMARK VISIBLE AT THE CRIMP (RESULTING FROM USE OF PROPER CRIMPING DEVICES) AND WEATHER-PROOFED WITH HEAT SHRINK.
14. ALL CONNECTION HARDWARE SHALL BE TYPE 3-16 STAINLESS STEEL (NOT ATTRACTED TO MAGNETS).
15. ELECTRICAL SERVICE EQUIPMENT GROUNDING SHALL COMPLY WITH NEC, ARTICLE 250-82 AND SHALL BOND ALL (E) AND NEW GROUNDING ELECTRODES. NEW GROUNDING ELECTRODE SHALL INCLUDE BUT NOT LIMITED TO GROUND RODS.

**TESTING AND EQUIPMENT TURN UP REQUIREMENTS:**

1. RF CABLE, DATA CABLE, RADIO EQUIPMENT AND BACK HAUL EQUIPMENT TESTING WILL COMPLY WITH CURRENT INDUSTRY STANDARDS AND OR THOSE STANDARDS OF THE EQUIPMENT MANUFACTURER OR PROVIDED TO THE CONTRACTOR PRIOR TO TESTING.
2. CONTRACTOR WILL USE THE APPROPRIATE CALIBRATED TESTING EQUIPMENT IN THE TESTING OF RF CABLE, DATA CABLE, RADIO EQUIPMENT AND BACK HAUL EQUIPMENT THAT MEET INDUSTRY STANDARDS OF THE MANUFACTURER OR THOSE STANDARDS PROVIDED TO THE CONTRACTOR PRIOR TO TESTING.
3. CONTRACTOR TO VERIFY AND RECORD ALL TEST RESULTS AND PROVIDE THESE RESULTS WITHIN THE FINAL CLOSE OUT PACKAGE.
4. ALL PERSONNEL INVOLVED IN THE TESTING OF RF CABLE, DATA CABLE, RADIO EQUIPMENT AND BACK HAUL EQUIPMENT WILL BE REQUIRED TO HAVE BEEN TRAINED AND OR CERTIFIED IN THE PROPER TESTING OF RF CABLE, DATA CABLE, RADIO EQUIPMENT AND BACK HAUL EQUIPMENT.
5. ALL TEST RESULTS SHALL BE TIME STAMPED, RECORDED AND PRESENTED PRIOR TO ENERGIZING AND TURN UP OF ANY EQUIPMENT.
6. GPS EQUIPMENT IS NOT TO BE TESTED OR ATTACHED TO ANY CABLING DURING TESTING, DOING SO WILL DAMAGE THE GPS UNIT.
7. PRIOR TO TESTING IF THE CONTRACTOR HAS ANY QUESTIONS ABOUT THE TESTING PROCEDURES THEY ARE TO CALL AND OBTAIN ASSISTANCE FROM A QUALIFIED DESIGNATED TESTING REPRESENTATIVE.
8. EQUIPMENT IS NOT TO BE ENERGIZED UNTIL ALL TESTING HAS BEEN COMPLETED, APPROVED AND THE APPROPRIATE AUTHORITY HAS BEEN NOTIFIED AND GIVEN APPROVAL TO ENERGIZE THE EQUIPMENT.

**SITE WORK NOTES:**

1. DO NOT EXCAVATE OR DISTURB BEYOND THE PROPERTY LINES OR LEASE LINES, UNLESS OTHERWISE NOTED.
2. SIZE, LOCATION AND TYPE OF ANY UNDERGROUND UTILITIES OR IMPROVEMENTS SHALL BE ACCURATELY NOTED AND PLACED ON AS-BUILT DRAWINGS BY GENERAL CONTRACTOR AND ISSUED TO ARCHITECT/ENGINEER AT COMPLETION OF PROJECT.
3. ALL (E) UTILITIES, FACILITIES, CONDITIONS AND THEIR DIMENSIONS SHOWN ON PLANS HAVE BEEN PLOTTED FROM AVAILABLE RECORDS. THE ENGINEER AND OWNER ASSUME NO RESPONSIBILITY WHATSOEVER AS TO THE SUFFICIENCY OR ACCURACY OF THE INFORMATION SHOWN ON THE PLANS OR THE MANNER OF THEIR REMOVAL OR ADJUSTMENT. CONTRACTOR SHALL BE RESPONSIBLE FOR DETERMINING EXACT LOCATION OF ALL (E) UTILITIES AND FACILITIES PRIOR TO START OF CONSTRUCTION. CONTRACTOR SHALL ALSO OBTAIN FROM EACH UTILITY COMPANY DETAILED INFORMATION RELATIVE TO WORKING SCHEDULES AND METHODS OF REMOVING OR ADJUSTING (E) UTILITIES.
4. CONTRACTOR SHALL VERIFY ALL (E) UTILITIES BOTH HORIZONTALLY AND VERTICALLY PRIOR TO START OF CONSTRUCTION. ANY DISCREPANCIES OR DOUBTS AS TO THE INTERPRETATION OF PLANS SHALL BE IMMEDIATELY REPORTED TO THE ARCHITECT/ENGINEER OR MOBILITE CM FOR RESOLUTION AND INSTRUCTION, AND NO FURTHER WORK SHALL BE PERFORMED UNTIL THE DISCREPANCY IS CHECKED AND CORRECTED BY THE ARCHITECT/ENGINEER. FAILURE TO SECURE SUCH INSTRUCTION MEANS CONTRACTOR WILL HAVE WORKED AT THEIR OWN RISK AND EXPENSE. CONTRACTOR SHALL CALL LOCAL UTILITY LOCATE HOT LINE, SUCH AS 811, FOR UTILITY LOCATIONS A MINIMUM OF 48 HOURS PRIOR TO START OF CONSTRUCTION.
5. ALL NEW AND (E) UTILITY STRUCTURES ON SITE AND IN AREAS TO BE DISTURBED BY CONSTRUCTION SHALL BE ADJUSTED TO FINISH ELEVATIONS PRIOR TO FINAL INSPECTION OF WORK. ANY COST RELATED TO ADJUSTING (E) STRUCTURES SHALL BE BORNE SOLELY BY THE CONTRACTOR.
6. GRADING OF THE SITE WORK AREA IS TO BE SMOOTH AND CONTINUOUS IN SLOPE AND IS TO FEATHER INTO (E) GRADES AT THE GRADING LIMITS.
7. ALL TEMPORARY EXCAVATIONS FOR THE INSTALLATION OF FOUNDATIONS, UTILITIES, ETC., SHALL BE PROPERLY LAID BACK OR BRACED IN ACCORDANCE WITH CORRECT OCCUPATIONAL SAFETY AND HEALTH ADMINISTRATION (OSHA) REQUIREMENTS.



PRESCOTT COMMUNICATIONS, INC.  
1560 Sepulveda Blvd. Suite 1, Mission Hills, CA 91345  
Phone No. (818)626-2292 Fax No. (818)626-0768

PROJECT NO: 9CAB013243

DRAWN BY: MD

CHECKED BY: JM

NO.	DATE	REVISION
1	05/26/17	ISSUE CONSTRUCTION
2	05/21/17	ADD SMART METER
3	09/26/17	REVISED PER PG&E STANDARDS

IT IS A VIOLATION OF THE LAW FOR ANY PERSON UNLESS THEY ARE ACTING UNDER THE DIRECTION OF A LICENSED PROFESSIONAL ENGINEER TO ALTER THIS DOCUMENT.

9CAB013243  
OAKLAND, CA 94602  
(E) 26'-0" STEEL LIGHT POLE

SHEET TITLE  
GENERAL NOTES

SHEET NUMBER  
GN-2



SITE WORK NOTES, CONTD.

8. STRUCTURAL FILLS SUPPORTING PAVEMENTS SHALL BE COMPACTED TO 95% OF MAXIMUM STANDARD PROCTOR DRY DENSITY, UNLESS OTHERWISE NOTED.
9. NEW GRADES NOT IN BUILDING AND DRIVEWAY IMPROVEMENT AREA TO BE ACHIEVED BY FILLING WITH APPROVED CLEAN FILL AND COMPACTED TO 95% OF STANDARD PROCTOR DENSITY.
10. ALL FILL SHALL BE PLACED IN UNIFORM LIFTS. THE LIFTS THICKNESS SHOULD NOT EXCEED THAT WHICH CAN BE PROPERLY COMPACTED THROUGHOUT ITS ENTIRE DEPTH WITH THE EQUIPMENT AVAILABLE.
11. ANY FILLS PLACED ON (E) SLOPES THAT ARE STEEPER THAN 10 HORIZONTAL TO 1 VERTICAL SHALL BE PROPERLY BENCHED INTO THE (E) SLOPE AS DIRECTED BY A GEOTECHNICAL ENGINEER.
12. CONTRACTOR SHALL CLEAN ENTIRE SITE AFTER CONSTRUCTION SUCH THAT NO DEBRIS, PAPER, TRASH, WEEDS, BRUSH, EXCESS FILL OR ANY OTHER DEPOSITS WILL REMAIN. ALL MATERIALS COLLECTED DURING CLEANING OPERATIONS SHALL BE DISPOSED OF OFF-SITE BY THE GENERAL CONTRACTOR.
13. ALL TREES AND SHRUBS WHICH ARE NOT IN DIRECT CONFLICT WITH THE IMPROVEMENTS SHALL BE PROTECTED BY THE GENERAL CONTRACTOR.

14. ALL SITE WORK SHALL BE CAREFULLY COORDINATED BY GENERAL CONTRACTOR WITH LOCAL UTILITY COMPANY, TELEPHONE COMPANY, AND ANY OTHER UTILITY COMPANIES HAVING JURISDICTION OVER THIS LOCATION.

ENVIRONMENTAL NOTES:

1. ALL WORK PERFORMED SHALL BE DONE IN ACCORDANCE WITH ISSUED PERMITS. THE CONTRACTOR SHALL BE RESPONSIBLE FOR PAYMENT OF FEES AND PROPER CLEAN UP FOR AREAS IN VIOLATION.
2. CONTRACTOR SHALL BE RESPONSIBLE FOR CONSTRUCTION AND MAINTENANCE OF EROSION AND SEDIMENTATION CONTROLS DURING CONSTRUCTION FOR PROTECTION OF ADJACENT PROPERTIES, ROADS AND WATERWAYS. ALL EROSION AND SEDIMENTATION CONTROLS SHALL BE MAINTAINED IN PLACE THROUGH FINAL JURISDICTIONAL INSPECTION & RELEASE OF SITE.
3. CONTRACTOR SHALL INSTALL/CONSTRUCT ALL NECESSARY SEDIMENT/SILT CONTROL FENCING AND PROTECTIVE MEASURES AS REQUIRED BY THE LOCAL JURISDICTION WITHIN THE LIMITS OF SITE DISTURBANCE PRIOR TO CONSTRUCTION.
4. NO SEDIMENT SHALL BE ALLOWED TO EXIT THE PROPERTY. THE CONTRACTOR IS RESPONSIBLE FOR TAKING ADEQUATE MEASURES FOR CONTROLLING EROSION. ADDITIONAL SEDIMENT CONTROL FENCING MAY BE REQUIRED IN ANY AREAS SUBJECT TO EROSION.
5. THE CONTRACTOR IS RESPONSIBLE FOR MAINTAINING POSITIVE DRAINAGE ON THE SITE AT ALL TIMES WITH SILT AND EROSION CONTROL MEASURES MAINTAINED ON THE DOWNSTREAM SIDE OF SITE DRAINAGE. ANY DAMAGE TO ADJACENT PROPERTY AS A RESULT OF EROSION WILL BE CORRECTED AT THE CONTRACTORS EXPENSE.
6. CONTRACTOR SHALL BE RESPONSIBLE FOR DAILY INSPECTIONS AND ANY REPAIRS OF ALL SEDIMENT CONTROL MEASURES INCLUDING SEDIMENT REMOVAL AS NECESSARY.
7. CLEARING OF VEGETATION AND TREE REMOVAL SHALL BE ONLY AS PERMITTED AND BE HELD TO A MINIMUM. ONLY TREES NECESSARY FOR CONSTRUCTION OF THE FACILITIES SHALL BE REMOVED.
8. SEEDING AND MULCHING AND/OR SODDING OF THE SITE WILL BE ACCOMPLISHED AS SOON AS POSSIBLE AFTER COMPLETION OF THE PROJECT FACILITIES AFFECTING LAND DISTURBANCE.
9. CONTRACTOR SHALL PROVIDE ALL EROSION AND SEDIMENTATION CONTROL MEASURES AS REQUIRED BY LOCAL, COUNTY AND STATE CODES AND ORDINANCES TO PROTECT EMBANKMENTS FROM SOIL LOSS AND TO PREVENT ACCUMULATION OF SOIL AND SILT IN STREAMS AND DRAINAGE PATHS LEAVING THE CONSTRUCTION AREA. THIS MAY INCLUDE, BUT IS NOT LIMITED TO SUCH MEASURES AS SILT FENCES, STRAW BALE SEDIMENT BARRIERS, AND CHECK DAMS.
10. RIP RAP OF SIZES INDICATED SHALL CONSIST OF CLEAN, HARD, SOUND, DURABLE, UNIFORM IN QUALITY STONE FREE OF ANY DETRIMENTAL QUANTITY OF SOFT, FRAGILE, THIN, ELONGATED OR LAMINATED PIECES, DISINTEGRATED MATERIAL, ORGANIC MATTER, OIL, ALKALI OR OTHER DELETERIOUS SUBSTANCES.

11. GC TO PLACE FILTER MATERIAL AT ALL CATCH BASINS ADJACENT TO CONSTRUCTION SITE TO PREVENT SOLID WASTE CONTAMINATION FROM ENTERING SEWER SYSTEM.

FOUNDATION, EXCAVATION AND BACKFILL NOTES:

1. ALL FINAL GRADED SLOPES SHALL BE A MAXIMUM OF 3 HORIZONTAL TO 1 VERTICAL, UNLESS OTHERWISE NOTED.
2. BACKFILL OF POLE SHALL BE PERFORMED IN ONE OF THREE OPTIONS:
  - A. PREFERRED: RAINBOW INDUSTRIES POLE SETTING FOAM SHALL BE INSTALLED PER MANUFACTURER SPECS. FOAM SHALL ALWAYS BE USED FOR POOR SOILS.
  - B. SECONDARY: CONCRETE (REQUIRES MOISTURE CM WRITTEN APPROVAL) ALLOWABLE SOIL PRESSURE = 2000 PSF (ASSUMED). NON-NATIVE SOILS SHALL BE REMOVE FROM BORE AREA AND SHALL NOT BE REUSED FOR BACKFILL.
3. ALL EXCAVATIONS PREPARED FOR PLACEMENT OF CONCRETE SHALL BE OF UNDISTURBED SOILS, SUBSTANTIALLY HORIZONTAL AND FREE FROM ANY LOOSE, UNSUITABLE MATERIAL OR FROZEN SOILS, AND WITHOUT THE PRESENCE OF POUNDING WATER. DEWATERING FOR EXCESS GROUND WATER SHALL BE PROVIDED WHEN REQUIRED. COMPACTION OF SOILS UNDER CONCRETE PAD FOUNDATIONS SHALL NOT BE LESS THAN 95% OF THE MODIFIED PROCTOR MAXIMUM DRY DENSITY FOR THE SOIL IN ACCORDANCE WITH ASTM D1557.
4. CONCRETE FOUNDATIONS SHALL NOT BE PLACED ON ORGANIC OR UNSUITABLE MATERIAL. IF ADEQUATE BEARING CAPACITY IS NOT ACHIEVED AT THE DESIGNED EXCAVATION DEPTH, THE UNSATISFACTORY SOIL SHALL BE EXCAVATED TO ITS FULL DEPTH AND EITHER BE REPLACED WITH MECHANICALLY COMPACTED GRANULAR MATERIAL OR THE EXCAVATION SHALL BE FILLED WITH CONCRETE OF THE SAME TYPE SPECIFIED FOR THE FOUNDATION. CRUSHED STONE MAY BE USED TO STABILIZE THE BOTTOM OF THE EXCAVATION. ANY STONE SUB-BASE MATERIAL, IF USED, SHALL NOT SUBSTITUTE FOR REQUIRED THICKNESS OF CONCRETE.
5. ALL EXCAVATIONS SHALL BE CLEAN OF UNSUITABLE MATERIAL SUCH AS VEGETATION, TRASH, DEBRIS, AND SO FORTH PRIOR TO BACK FILLING. BACK FILL SHALL CONSIST OF APPROVED MATERIALS SUCH AS EARTH, LOAM, SANDY CLAY, SAND AND GRAVEL, OR SOFT SHALE, FREE FROM CLODS OR LARGE STONES. 0'ER 2 1/2" MAX DIMENSIONS. ALL BACK FILL SHALL BE PLACED IN COMPACTED LAYERS.
6. ALL FILL MATERIALS AND FOUNDATION BACK FILL SHALL BE PLACED IN MAXIMUM 6" THICK LIFTS BEFORE COMPACTION. EACH LIFT SHALL BE METTED IF REQUIRED AND COMPACTED TO NOT LESS THAN 95% OF THE MODIFIED PROCTOR MAXIMUM DRY DENSITY FOR SOIL IN ACCORDANCE WITH ASTM D1557.
7. NEWLY PLACED CONCRETE FOUNDATIONS SHALL CURE A MINIMUM OF 72 HRS PRIOR TO BACK FILLING.
8. FINISHED GRADING SHALL BE SLOPED TO PROVIDE POSITIVE DRAINAGE AND PREVENT STANDING WATER. THE FINAL (FINISH) ELEVATION OF SLAB FOUNDATIONS SHALL SLOPE AWAY IN ALL DIRECTIONS FROM THE CENTER. FINISH GRADE OF CONCRETE PADS SHALL BE A MAXIMUM OF 4 INCHES ABOVE FINAL FINISH GRADE ELEVATIONS. PROVIDE SURFACE FILL GRAVEL TO ESTABLISH SPECIFIED ELEVATIONS WHERE REQUIRED.
9. NEWLY GRADED GRAVEL SURFACE AREAS TO RECEIVE GRAVEL SHALL BE COVERED WITH GEOTEXTILE FABRIC TYPE: TYPAR-3401 AS MANUFACTURED BY TYPAR GEOSYNTHETICS OR AN APPROVED EQUIVALENT, SHOWN ON PLANS. THE GEOTEXTILE FABRIC SHALL BE BLACK IN COLOR TO CONTROL THE RECURRENT OF VEGETATIVE GROWTH AND EXTEND TO WITHIN 1 FOOT OUTSIDE THE SITE FENCING OR ELECTRICAL GROUNDING SYSTEM PERIMETER WHOM EVER IS GREATER. ALL FABRIC SHALL BE COVERED WITH A MINIMUM OF 4" DEEP COMPACTED STONE OR GRAVEL AS SPECIFIED, I.E. FDOT TYPE NO. 57 FOR FENCED COMPOUND, FDOT TYPE 110, 67 FOR ACCESS DRIVE AREA, UNLESS OTHERWISE NOTED.
10. IN ALL AREAS TO RECEIVE FILL, REMOVE ALL VEGETATION, TOPSOIL, DEBRIS, WET AND UNSATISFACTORY SOIL MATERIALS, OBSTRUCTIONS, AND DELETERIOUS MATERIALS FROM GROUND SURFACE. FLOW STRIP OR BREAK UP SLOPED SURFACES STEEPER THAN 1 VERTICAL TO 4 HORIZONTAL SUCH THAT FILL MATERIAL WILL BIND WITH (E)/PREPARED SOIL SURFACE.
11. WHEN SUB GRADE OR PREPARED GROUND SURFACE HAS A DENSITY LESS THAN THAT REQUIRED FOR THE FILL MATERIAL, SCARIFY THE GROUND SURFACE TO DEPTH REQUIRED, PULVERIZE, MOISTURE-CONDITION AND/OR AERATE THE SOILS AND RECOMPACT TO THE REQUIRED DENSITY PRIOR TO PLACEMENT OF FILLS.
12. IN AREAS WHICH (E) GRAVEL SURFACING IS REMOVED OR DISTURBED DURING CONSTRUCTION OPERATIONS, REPLACE GRAVEL SURFACING TO MATCH ADJACENT

GRAVEL SURFACING AND RESTORED TO THE SAME THICKNESS AND COMPACTION AS SPECIFIED. ALL RESTORED GRAVEL SURFACING SHALL BE FREE FROM CORRUGATIONS AND WAVES.

13. (E) GRAVEL SURFACING MAY NOT BE REUSED.

14. GRAVEL SUB SURFACE SHALL BE PREPARED TO REQUIRED COMPACTION AND SUB GRADE ELEVATIONS BEFORE GRAVEL SURFACING IS PLACED AND/OR RESTORED. ANY LOOSE OR DISTURBED MATERIALS SHALL BE THOROUGHLY COMPACTED AND ANY DEPRESSIONS IN THE SUB GRADE SHALL BE FILLED AND COMPACTED WITH APPROVED SELECTED MATERIAL. GRAVEL SURFACING MATERIAL SHALL NOT BE USED FOR FILLING DEPRESSIONS IN THE SUB GRADE.

15. PROTECT (E) GRAVEL SURFACING AND SUB GRADE IN AREAS WHERE EQUIPMENT LOADS WILL OPERATE. USE PLANKING MATS OR OTHER SUITABLE PROTECTION DESIGNED TO SPREAD EQUIPMENT LOADS AS MAY BE NECESSARY. REPAIR ANY DAMAGE TO (E) GRAVEL SURFACING OR SUB GRADE WHERE SUCH DAMAGE IS DUE TO THE CONTRACTORS OPERATIONS.

16. DAMAGE TO (E) STRUCTURES AND/OR UTILITIES RESULTING FROM CONTRACTORS NEGLIGENCE SHALL BE REPAIRED AND/OR REPLACED TO THE OWNERS SATISFACTION AT NO ADDITIONAL COST TO THE CONTRACT.

17. ALL SUITABLE BORROW MATERIAL FOR BACK FILL OF THE SITE SHALL BE INCLUDED IN THE BID. EXCESS TOPSOIL AND UNSUITABLE MATERIAL SHALL BE DISPOSED OF OFF SITE AT LOCATIONS APPROVED BY GOVERNING AGENCIES AT NO ADDITIONAL COST TO THE CONTRACT.

MISCELLANEOUS MATERIALS

FROM TIME TO TIME IT MAY BE NECESSARY TO MAKE MINOR ADJUSTMENTS TO ACCOMMODATE, LEVEL OR SPACE ANTENNA MOUNTS AND EQUIPMENT. EXAMPLE: ADDING A WASHER OR SHIM TO LEVEL OUT A BRACKET OR MOUNT TO MEET SPECIFICATIONS, HAVING TO OFFSET OR SPACE A BRACKET OR MOUNT DUE TO FLANGES AND OR OTHER SMALL PROTRUSIONS ON A POLE TOP ASSEMBLY. ANY MATERIALS, NUTS, BOLTS, SHIMS OR SPACERS USED TO ACCOMMODATE ADJUSTMENTS TO ANTENNA MOUNTS AND EQUIPMENT MUST BE PERMANENTLY AFFIXED, BOLTED TO THE MOUNT, BRACKET OR POLE, AS NEVER TO BECOME A FALL HAZARD. ALL MATERIALS NUTS, BOLTS, SHIMS OR SPACERS USED IN MINOR ADJUSTMENTS, MUST BE EITHER STAINLESS STEEL OR GALVANIZED; HALF WASHERS ARE PROHIBITED. ANY MINOR ADJUSTMENTS TO ACCOMMODATE ANTENNA MOUNTS AND EQUIPMENT SHOULD BE DONE IN A PROFESSIONAL MANNER WITH SAFETY AND AESTHETICS IN MIND. SHOULD YOU HAVE ANY QUESTIONS CONTACT YOUR ASSIGNED CONSTRUCTION PROJECT MANAGER OR ENGINEER FOR GUIDANCE.



PRESCOTT COMMUNICATIONS, INC.  
1560 Southside Blvd. Suite 1, Mission Hills, CA 91345  
Phone No. (916)924-2322 Fax No. (916)924-2196

PROJECT NO: 9CAB013243

DRAWN BY: MD  
CHECKED BY: JM

0	05/26/17	SITE CONSTRUCTION
1	05/31/17	ADDED SMART METER
2	09/26/17	REVISED PER PDM STANDARDS

IF IT IS A VIOLATION OF THE LAW FOR ANY PERSON, SAID TO BE ACTING UNDER THE DIRECTION OF A LICENSED PROFESSIONAL ENGINEER, TO ALTER THIS DOCUMENT

9CAB013243  
OAKLAND, CA 94602  
(E) 26'-0" STEEL LIGHT POLE

SHEET TITLE  
GENERAL NOTES

SHEET NUMBER  
GN-3



**DURATION NOTES**

1. "ROAD WORK AHEAD" and the "BE PREPARED TO STOP" signs may be omitted if all of the following conditions are met:
  - a. Work operations are 60 minutes or less
  - b. Speed limit is 45 MPH or less
  - c. No sight obstructions to vehicles approaching the work area for a distance equal to the buffer space
  - d. Vehicles in the work area have high-intensity, rotating, flashing, oscillating, or strobe lights operating
  - e. Volume and complexity of the roadway has been considered

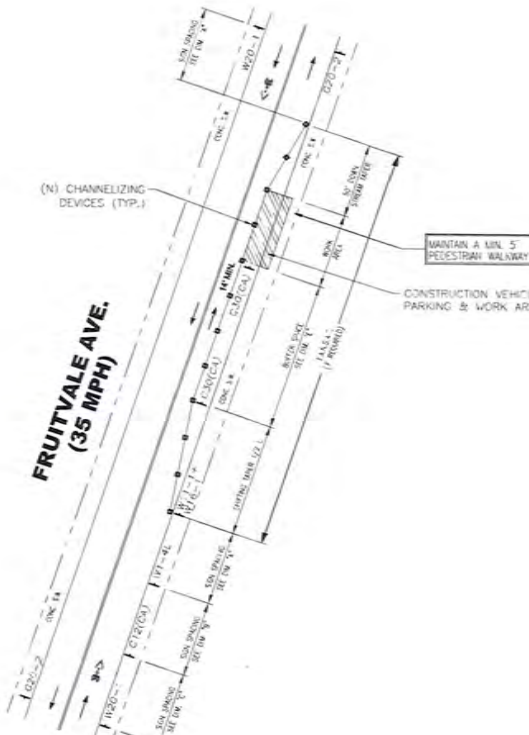

**TRAFFIC CONTROL PLANS**

**GENERAL NOTES**

1. ALL WORK AND MATERIALS SHALL COMPLY WITH THE WORK AREA TRAFFIC CONTROL HANDBOOK (M-10) 2016 EDITION.
2. ALL STRIPING AND MARKINGS SHALL CONFORM TO THE STATE OF CALIFORNIA STANDARD PLANS AND SPECIFICATIONS, INCLUDING STANDARD PLAN A-20, DETAILS.
3. THE CONTRACTOR SHALL PROVIDE FOR ACCESS TO ALL ADJACENT PROPERTIES.
4. FLASHING YELLOW BEACONS, TYPE "B", SHALL BE USED ON ALL W20-1 SIGNS AND ON ALL TYPE B BARRICADES GUARDING THE WORK AREA OVERNIGHT.
5. ALL SIGNS SHALL BE REFLECTORIZED AND STANDARD SIZE.
6. ALL TUBULAR DELINEATORS AND CONES SHALL BE 28" MINIMUM HEIGHT, REFLECTORIZED AND MAINTAINED ERECT IN THE INDICATED POSITION AT ALL TIMES, AND SHALL BE REPAIRED, REPLACED, OR CLEARED AS NECESSARY TO PRESERVE THEIR APPEARANCE AND CONTINUITY, AND SHALL INCLUDE A 12" HIGH-INTENSITY REFLECTORIZED SLEEVE, IF USED DURING NIGHT-TIME HOURS.
7. THE CONTRACTOR SHALL MAINTAIN, ON A CONTINUOUS BASIS, ALL SIGNS, DELINEATORS, BARRICADES, ETC., TO ENSURE PROPER FLOW AND SAFETY OF TRAFFIC DURING CONSTRUCTION.
8. THE CONTRACTOR SHALL HAVE ALL SIGNS, DELINEATORS, BARRICADES, ETC., PROPERLY INSTALLED PRIOR TO COMMENCING CONSTRUCTION.
9. CONSTRUCTION OPERATIONS SHALL BE CONDUCTED IN SUCH A MANNER AS TO CAUSE AS LITTLE INCONVENIENCE AS POSSIBLE TO ABUTTING PROPERTY OWNERS.
10. ADDITIONAL TRAFFIC CONTROLS, TRAFFIC SIGNS, OR BARRICADES MAY BE REQUIRED IN THE FIELD. THE CONTRACTOR SHALL BE RESPONSIBLE FOR THE PLACEMENT OF ANY ADDITIONAL DEVICES NECESSARY TO ASSURE SAFETY TO THE PUBLIC AT ALL TIMES DURING CONSTRUCTION.
11. EXACT LOCATION AND TYPE OF CONSTRUCTION SIGNS SHALL BE DIRECTED BY THE ENGINEER BASED UPON CONSTRUCTION CONDITIONS.
12. MOVE DELINEATORS AND OR CONES TO SIDEWALK DURING NON-WORKING HOURS. REMOVE BARRICADES ETC FROM TRAVEL LANE.
13. REMOVE OR TURN OFF SIGNS DURING NON-WORK HOURS.
14. ALL CONFLICTING LINES, EXISTING CURB PAINT, AND MARKINGS SHALL BE REMOVED BY HOT SANDBLASTING OR OTHER APPROVED METHOD PRIOR TO INSTALLATION OF NEW/TEMPORARY STRIPING. ALL CONFLICTING RAISED PAVEMENT MARKERS SHALL BE REMOVED. PAVEMENT THAT IS DAMAGED DUE TO REMOVAL OF MARKERS SHALL BE REPAIRED TO THE SATISFACTION OF THE CITY ENGINEER AND/OR STATE INSPECTOR.

**NOTES**

1. INGRESS AND EGRESS MUST BE PROVIDED TO ALL DRIVEWAYS AT ANY TIME. USE BULL NOSE TO TERMINATE TAPER AT DRIVEWAYS.
2. STEEL PLATES TO BE USED TO MAINTAIN TRAFFIC FLOW ON ALL DRIVEWAYS.

**SIGNS**



\* ADDITIONAL SIGNS MAY BE REQUIRED TO ACCOMMODATE ACTUAL FIELD CONDITIONS.

**PARTIAL RIGHT LANE CLOSURE  
2016 WATCH PAGE 35**

**LEGEND**

- CHAINELIZING DEVICE
- ⊥ SIGN
- ▨ WORK SPACE
- ⌋ FLAGGER
- ➔ DIRECTION OF TRAFFIC



**TEMPORARY TRAFFIC CONTROL PLAN DIMENSION GUIDELINES**

SPEED LIMIT (MPH)	ADVANCE WARNING SIGN SPACING (ft)		BUFFER SPACE (ft)		WORK SPACE (ft)		CHANNELIZING DEVICE SPACING (ft)		CHANNELIZING DEVICE SPACING (ft)	
	MIN	MAX	MIN	MAX	MIN	MAX	MIN	MAX	MIN	MAX
25	100	125	65	85	1150	1460	215	240	12	12
35	200	180	80	100	2150	2730	240	270	14	14
45	250	240	125	150	2520	3270	270	300	17	17
60	250	320	180	210	3000	3750	300	330	20	20
70	350	340	230	270	3420	4290	330	360	23	23
50	350	600	300	360	4230	5310	360	400	25	25
60	500	600	330	400	4950	6150	390	430	25	25
70	500	700	360	450	5280	6540	420	460	25	25
80	500	780	390	480	5640	6960	450	500	25	25

- (1) Minus one (1) foot for each sign and signpost when used in the same location.
- (2) Advance spacing may be reduced by half if signs are used in a line on curves or bends.
- (3) Buffer space may be omitted in low-speed urban areas and should be omitted in high-speed urban areas.
- (4) The stopping sight distance should enable those users to see the primary flagger station and safety area.
- (5) Sign spacing in rural areas should be 300 ft.
- (6) \*\* Refer to 181(CA)

**TRAFFIC CONTROL PLAN**

SCALE: NOT TO SCALE



PROJECT NO: 9CAB013243  
DRAWN BY: MD  
CHECKED BY: JM

1	05/26/17	305 CONSTRUCTION
2	09/26/17	ADDED SMART METERS
3		REMOVED FROM SIGNATURES

IT IS A VIOLATION OF THE LAW FOR ANY PERSON, UNLESS THEY ARE ACTING UNDER THE DIRECTION OF A LICENSED PROFESSIONAL ENGINEER, TO ALTER THIS DOCUMENT.

9CAB013243  
OAKLAND, CA 94602  
(E) 26'-0" STEEL LIGHT POLE

SHEET TITLE  
TRAFFIC CONTROL PLAN

SHEET NUMBER  
TC-1



Existing

view from Fruitvale Avenue looking south at site

**mobilite**  
intelligent infrastructure

9CAB013243C / SF90XS0F1C  
Fruitvale Avenue & MacArthur Blvd, Oakland, CA  
Photosims Produced on 6-22-2017

Proposed





Existing

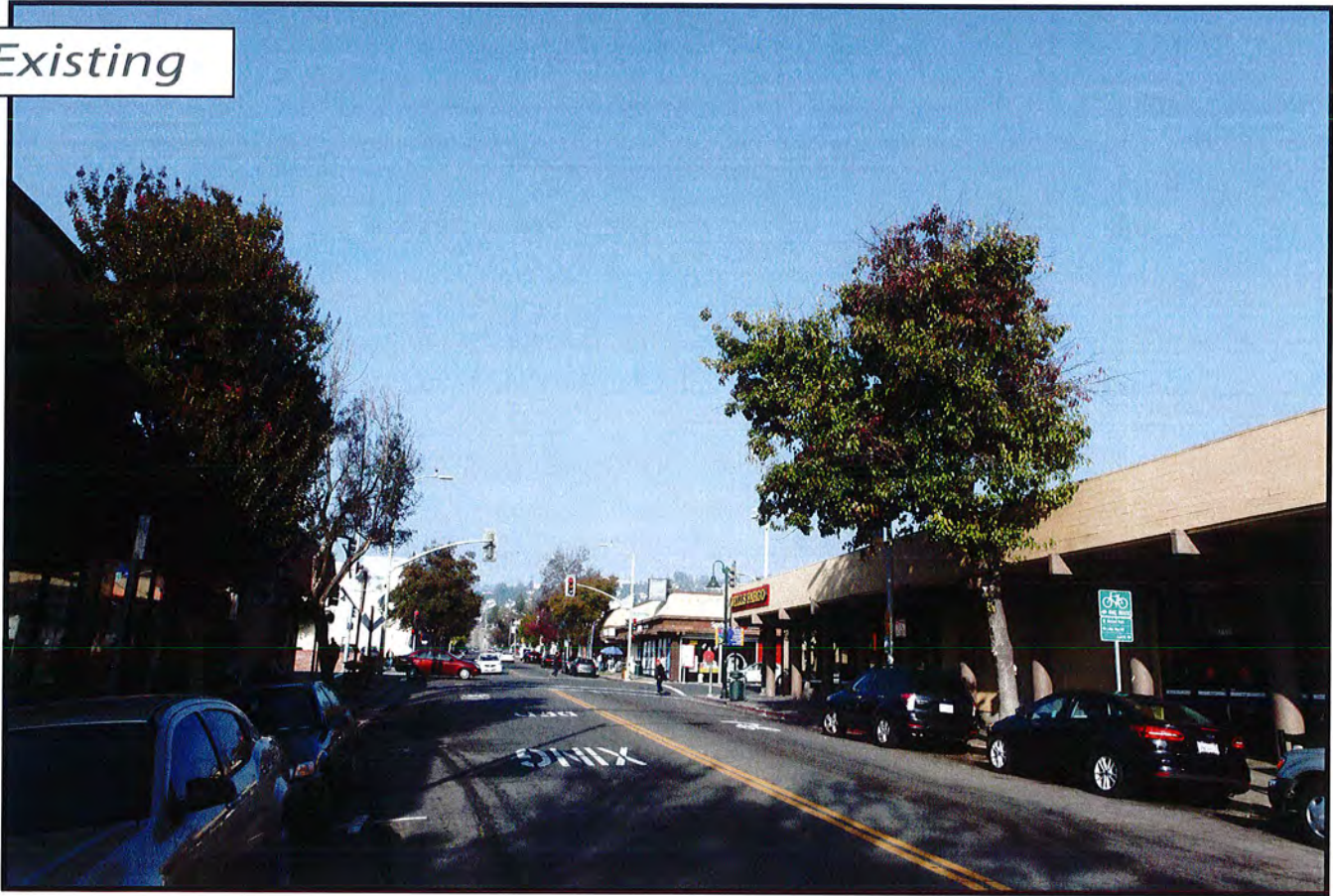

Proposed

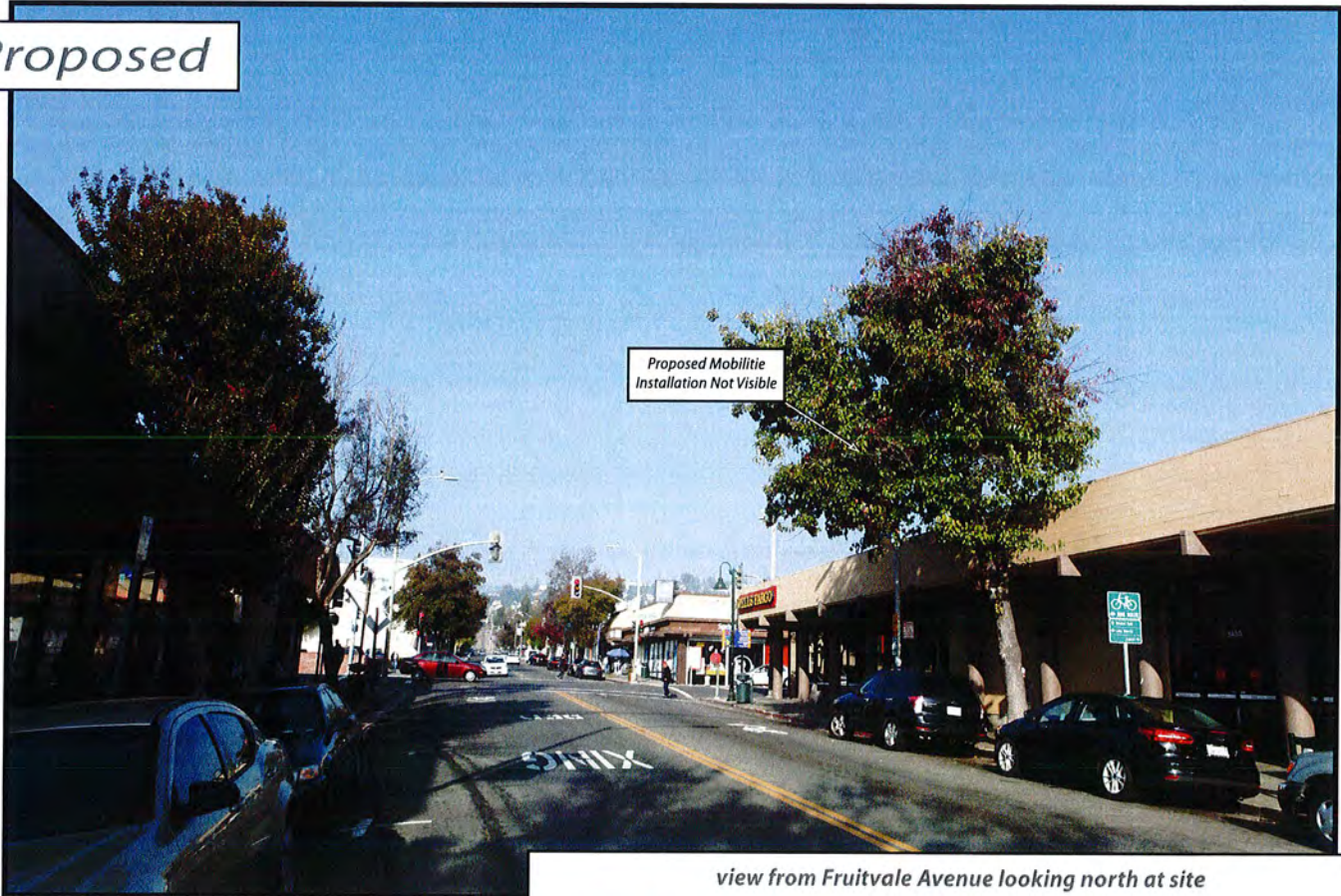

Proposed Mobilitie  
Installation Not Visible

view from Fruitvale Avenue looking north at site



Mobilitie, LLC  
2955 Red Hill Ave. Ste. 200  
Costa Mesa, CA 92626  
USA Tel: 714.415.4500  
www.mobilitie.com

# Alternative Site Analysis

## Proposed Small Cell Wireless Facility

**Applicant:** Mobilitie, LLC

**Site ID:** 9CAB013243/SF90XS0F1C

**Nearest Site Address:** Public Right of Way near 2215 Champion Street, Oakland, CA 94602

**Latitude/Longitude:** 37.80011, -122.21617

Mobilitie considered alternative sites on other street lights and utility poles in this area, but found them to not to be as desirable when taking into consideration coverage goals, constructability, geographic topography of the surrounding area, and potential visual impact in the surrounding area. The proposed location is desirable because of the limited obstructions in the area, allowing our antenna to effectively propagate a signal. Furthermore, the proposed location is the optimal solution for providing maximum coverage to the surrounding area identified. Additionally, by locating on an existing street light with equipment concealed, visual impact in the surrounding area is minimized.

Mobilitie is a privately held, CLEC (Competitive Local Exchange Carrier) regulated by the California Public Utilities Commission (CPUC) to provide telephone related services. By proposing this location on an existing street light in the public right of way, Mobilitie is proposing an appropriate co-location to existing infrastructure according to our rights under the CPUC.

The alternative locations that Mobilitie considered include, but are not limited to, the sites listed below:

Alternate B (37.800316, -122.215657) / Near 2221 MacArthur Blvd: This ornamental steel street light is located approximately 150 ft. northeast of our proposal. The City of Oakland has instructed Mobilitie LLC that we cannot attach our small cell equipment to ornamental street lights.

Alternate C (37.800191, -122.214940) / At the intersection of MacArthur Blvd and May Ct: This wooden utility pole is located approximately 350 ft. northeast of our proposal. The existence of a power riser running up this pole precludes it from being used there because there is not enough usable space on the pole for our facility.



# Radio Frequency- Electromagnetic Energy-EME Measurements & Compliance Report

**Site ID:** 9CAB013243C  
**Site Name:** 9CAB013243C  
**Market/Region:** California  
**Address:** FRUITVALE AVE. & MCARTHUR BLVD  
OAKLAND, CA 94602  
**Latitude:** 37.80011  
**Longitude:** -122.21617  
**Site Type:** Light Pole

### Compliance Status:

Proposed equipment at the site is compliant with FCC guidelines for General Population environments

### **Prepared for:**

Mobilitie, LLC  
2220 University Drive,  
Newport Beach, CA 92660

**By**  
**ATG LLC**

**Date:09/05/2017**

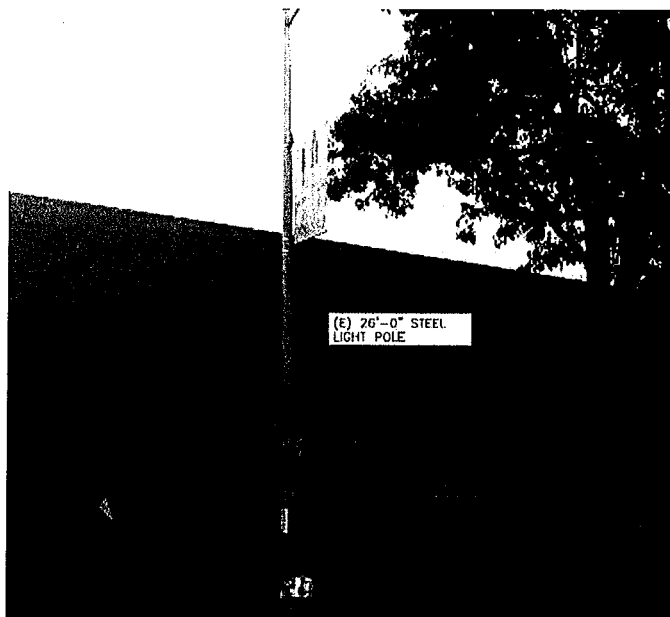

## TABLE OF CONTENT

<b>1 EXECUTIVE SUMMARY.....</b>	<b>3</b>
<b>2 MAXIMUM PERMISSIBLE EXPOSURE (MPE) MODELING RESULTS FOR PROPOSED SITE.....</b>	<b>3</b>
<b>3 ANTENNA INVENTORY.....</b>	<b>4</b>
<b>4 MODELING SUMMARY AND ASSUMPTIONS.....</b>	<b>4</b>
4.1 GENERAL MODEL ASSUMPTIONS.....	4
<b>5 PREPARER CERTIFICATION.....</b>	<b>5</b>
<b>APPENDIX A.....</b>	<b>6</b>
<b>FEDERAL COMMUNICATIONS COMMISSION (FCC) REQUIREMENTS.....</b>	<b>6</b>
<b>APPENDIX B.....</b>	<b>9</b>
<b>GLOSSARY OF TERMS.....</b>	<b>9</b>
<b>APPENDIX C.....</b>	<b>10</b>
<b>ROOFVIEW EXPORT FILE.....</b>	<b>10</b>

# 1 Executive Summary

## Purpose of Report

ATG LLC's RF Engineering has conducted radio frequency electromagnetic energy (RF-EME) modeling for Mobilitie LLC's site 9CAB013243C located at FRUITVALE AVE. & MCARTHUR BLVD OAKLAND, CA to determine RF-EME exposure levels from the carrier's proposed wireless communications equipment.

The Federal Communications Commission (FCC) has developed Maximum Permissible Exposure (MPE) limits for general public and occupational exposures to RF-EME. This report summarizes the results of RF-EME modeling in relation to relevant FCC compliance standards for limiting human exposure to RF-EME. The details of FCC defined exposure limits are provided in Appendix A of this report.

Analysis results included in this report are based on drawings dated May 31<sup>st</sup>, 2017.

## Statement of Compliance

Predictive modeling conducted using the original equipment manufacturers (OEMs) specifications for radio and antenna performance along with the supplied construction drawings dated May 31<sup>st</sup>, 2017, indicate there will be no exposure due to the carrier's proposed equipment on accessible ground-level walking surface at this site that exceeds the FCC's general public exposure limits.

Proposed equipment at the site is compliant with FCC guidelines for general population environments.

## 2 Maximum Permissible Exposure (MPE) Modeling Results for Proposed Site

The predictive modeling was conducted using the RoofView 5.0 suite of analysis tools. The modeling was conducted with the antennas operating at 100% capacity, all antenna channels transmitting simultaneously and the radio transmitters operating at full power. Obstructions (trees, buildings etc.) that would normally attenuate the signal are not taken into account. As a result, the predicted signal levels are more conservative (higher) than the actual signal levels would be during normal operations. The modeling calculations were made for an area 40'x 40' area with the equipment at the center.

**Table 1: Maximum Permissible Exposure- Summary**

Location	% of FCC General Public/Uncontrolled Exposure Limit	% of FCC Occupational/Controlled Exposure Limit	Power Density (mW/cm <sup>2</sup> )	Compliance Status
6ft above ground level	2.4	0.48	0.024	Compliant

### 3 Antenna Inventory

The Antenna Inventory shows all transmitting antennas on the site (see Table 2). This inventory was used by ATG to perform the software modeling of RF emissions. The inventory conforms with the submitted construction drawings which identifies the proposed mounting location of each antenna at the site. The exposure level is calculated for a person of height 6ft standing right below the devices at ground level.

**Table 2: Antenna Inventory**

Antenna ID	Carrier/Operator	Antenna Type	Frequency (MHz)	Technology	ERP (W)	Gain dBd	Mfg.	Model	Aperture (ft.)	Transmitter count	Horizontal BeamWidth (deg)	Z (6 ft. above Ground)
1	Mobilitie	Omni	2496	LTE	172.58	6.35	Alpha Wireless	AW3477-S	2.56	2	360	21.3
2	Mobilitie	LTE Relay BH	2496	LTE	1.93	9.85	Airspan	iR460	1.1	1	35	15.50

The table below details the operating power and Effective Radiated Power (ERP) for each carrier and frequency used in the modeling.

Frequency (MHz)	Power per Transmitter (Watts)	# of Transmitters	ERP (watts)
2496 (Omni)	20	2	172.58
2496 (UE Relay)	0.2	1	1.93

## 4 Modeling Summary and Assumptions

### 4.1 General Model Assumptions

The modeling was conducted using the antenna and radio maximum power values, while operating at full power with 100% duty cycle.

The site has been modeled with these assumptions to calculate the maximum RF energy density. ATG believes this to be a worst case analysis, based on data supplied by the OEMs and client. If actual power density measurements were made, ATG believes the real time measurements would indicate levels below those shown in the report.



## 5 Preparer Certification

I, Preparer, state that:

- I am an employee of ATG LLC that provides RF-EME safety and compliance services to the wireless communications industry.
- I have successfully completed 100s of RF-EME exposure studies and reports for various carriers.
- I am aware of the potential hazards from RF-EME exposures that would be classified "occupational" or "general public" under the FCC regulations.
- I am familiar with the FCC rules and regulations as well as OSHA regulations both in general and as they apply to RF-EME exposure.
- I have reviewed all the data related to the site and incorporated it into this study and Compliance Report such that the information contained in this report is true and accurate to the best of my knowledge.

*Ahmed Saadallah*

-----  
Ahmed Saadallah (RF Engineer)

## Appendix A

### Federal Communications Commission (FCC) Requirements

This appendix summarizes the policies, guidelines and requirements that were adopted by the FCC on August 1, 1996, amending Part 1 of Title 47 of the Code of Federal Regulations, and further amended by action of the Commission on August 25, 1997 (see 47 CFR Sections 1.1307(b), 1.1310, 2.1091 and 2.1093, as amended). Commission actions granting construction permits, licenses to transmit or renewals thereof, equipment authorizations or modifications in existing facilities, require the preparation of an Environmental Assessment (EA), as described in 47 CFR Section 1.1311, if the particular facility, operation or transmitter would cause human exposure to levels of radiofrequency (RF) electromagnetic fields in excess of these limits.

The potential hazard associated with the RF electromagnetic fields is discussed in OET Bulletin No. 65. This document can be obtained on the FCC website. ([https://transition.fcc.gov/Bureaus/Engineering\\_Technology/Documents/bulletins/oet65/oet65.pdf](https://transition.fcc.gov/Bureaus/Engineering_Technology/Documents/bulletins/oet65/oet65.pdf))

As per FCC guidelines there are two separate tiers of exposure limits that are based upon occupational/controlled exposure limits (for workers) and general public/uncontrolled exposure limits for members of the general public.

**Occupational/controlled exposure limits** apply to situations in which persons are exposed as a consequence of their employment and in which those persons who are exposed have been made fully aware of the potential for exposure and can exercise control over their exposure. Limits for occupational/controlled exposure also apply in situations when an individual is transient through a location where occupational/controlled limits apply provided he or she is made aware of the potential for exposure and can exercise control over his or her exposure by leaving the area or by some other appropriate means

**General public/uncontrolled exposure limits** apply to situations in which the general public may be exposed or in which persons who are exposed as a consequence of their employment and not be made fully aware of the potential for exposure or cannot exercise control over their exposure.

The FCC's MPE limits for field strength and power density are given in Table 1 (and in 47 CFR § 1.1310) Figure 1 is a graphical representation of the limits for plane-wave (far-field) equivalent power density versus frequency. The FCC's limits are generally applicable to all facilities, operations and transmitters regulated by the Commission, and compliance is expected with the appropriate guidelines. The power density limits vary by frequency to take into account the different types of equipment that may be in operation at a particular facility and are "time-averaged" limits to reflect different durations resulting from controlled and uncontrolled exposures.

**(A) Limits for Occupational/Controlled Exposure**

Frequency Range (MHz)	Electric Field Strength (E) (V/m)	Magnetic Field Strength (H) (A/m)	Power Density (S) (mW/cm <sup>2</sup> )	Averaging Time ( E  <sup>2</sup> ,  H  <sup>2</sup> or S) (minutes)
0.3-3.0	614	1.63	(100)*	6
3.0-30	1842/f	4.89/f	(900/f <sup>2</sup> )*	6
30-300	61.4	0.163	1.0	6
300-1500	--	--	f/300	6
1500-100,000	--	--	5	6

**(B) Limits for General Population/Uncontrolled Exposure**

Frequency Range (MHz)	Electric Field Strength (E) (V/m)	Magnetic Field Strength (H) (A/m)	Power Density (S) (mW/cm <sup>2</sup> )	Averaging Time ( E  <sup>2</sup> ,  H  <sup>2</sup> or S) (minutes)
0.3-1.34	614	1.63	(100)*	30
1.34-30	824/f	2.19/f	(180/f <sup>2</sup> )*	30
30-300	27.5	0.073	0.2	30
300-1500	--	--	f/1500	30
1500-100,000	--	--	1.0	30

f = frequency in MHz

\*Plane-wave equivalent power density

f = frequency in MHz \*Plane-wave equivalent power density

**Table 1**

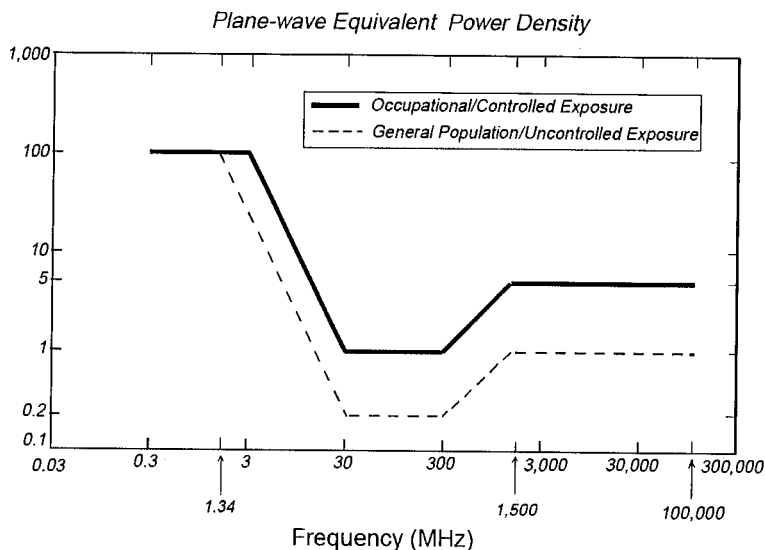

**Figure 1. FCC Limits for Maximum Permissible Exposure (MPE)**

**FCC Compliance Requirement**

In general, as specified in 47 C.F.R. 1.1307(b), as amended, when the FCC's guidelines are exceeded in an accessible area due to the emissions from multiple fixed transmitters the following policy applies. Actions necessary to bring the area into compliance with the guidelines are the shared responsibility of all licensees whose transmitter's contribution to the RF environment at the non-complying area exceeds 5% of the exposure limit (that applies to their particular transmitter) in terms of power density or the square of the electric or magnetic field strength.

For non-compliant sites, Occupational Safety and Health Administration (OSHA) set recommendations to make the sites compliant. The document can be found in the link: [https://www.osha.gov/dte/library/radiation/nir\\_stds\\_20021011/nir\\_stds\\_20021011.ppt](https://www.osha.gov/dte/library/radiation/nir_stds_20021011/nir_stds_20021011.ppt)

## Appendix B

### Glossary of Terms

1. *Electromagnetic Field (energy density)* – the electromagnetic energy contained in an infinitesimal volume divided by that volume.
2. *Exposure* – Exposure occurs whenever and wherever a person is subjected to electric, magnetic or electromagnetic fields other than those originating from physiological processes in the body and other natural phenomena.
3. *General Population / Uncontrolled Exposure* – applies to human exposure to RF fields when the general public is exposed or in which persons who are exposed as a consequence of their employment may not be made fully aware of the potential for exposure or cannot exercise control over their exposure. Therefore, members of the general public always fall under this category when exposure is not employment-related.
4. *Maximum Permissible Exposure (MPE)* – the rms and peak electric and magnetic field strength, their squares, or the plane-wave equivalent power densities associated with these fields to which a person may be exposed without harmful effect and with an acceptable safety factor.
5. *Occupational / Controlled Exposure* – applies to human exposure to RF fields when persons are exposed as a consequence of their employment and in which those persons who are exposed have been made fully aware of the potential for exposure and can exercise control over their exposure. Occupational/controlled exposure limits also apply where exposure is of a transient nature as a result of incidental passage through a location where exposure levels may be above general population/controlled limits.
6. *Power Density (S)* – Power per unit area normal to the direction of propagation, usually expressed in units of watts per square meter ( $W/m^2$ ) or, for convenience, units such as milliwatts per square centimeter ( $mW/cm^2$ ) or microwatts per square centimeter ( $\mu W/cm^2$ ).



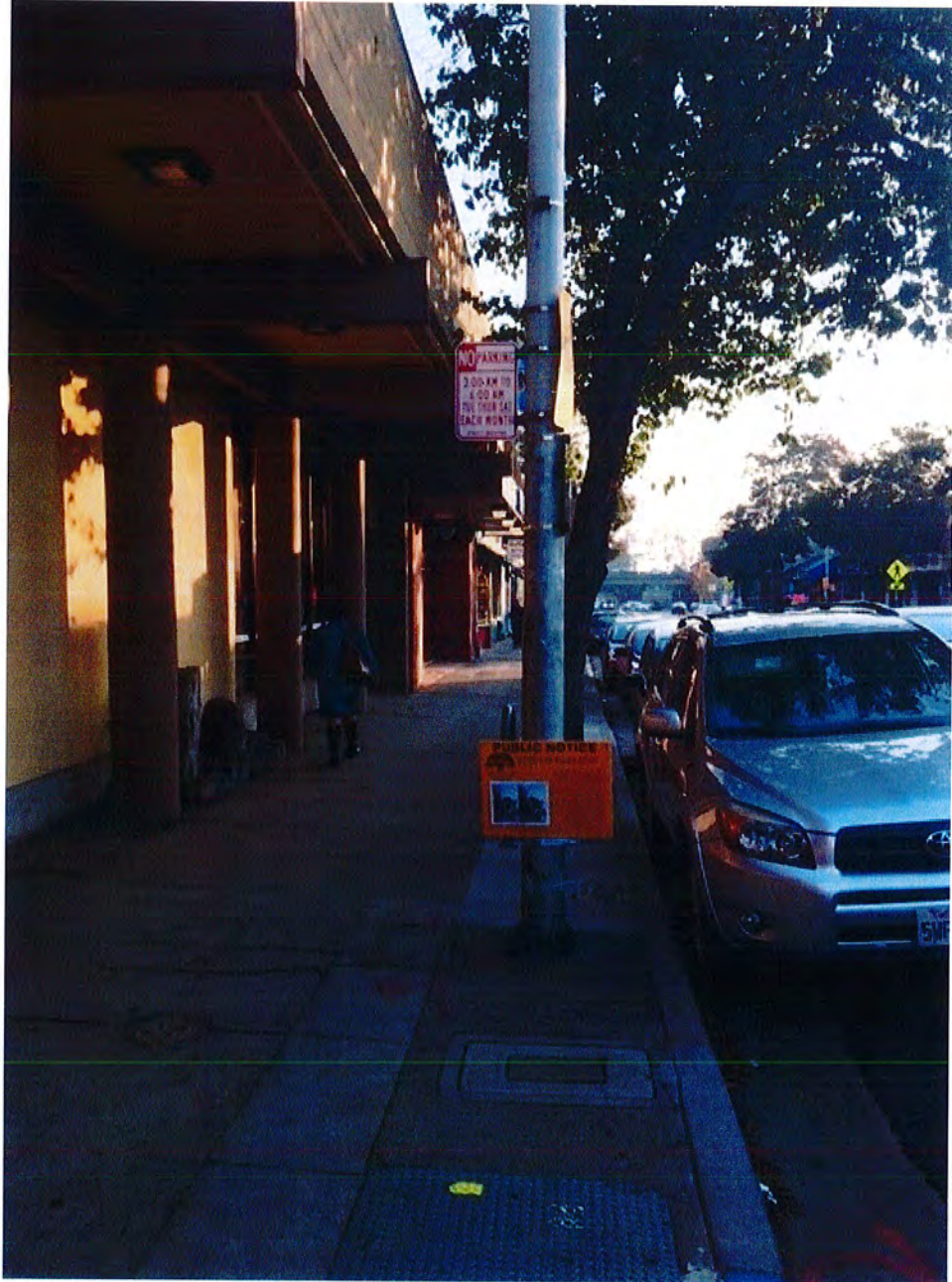

39-H





intelligent infrastructure

SITE ID/CASCADE ID-CANDIDATE LETTER:

9CAB013267/SF90XS0H5B

LATITUDE/LONGITUDE:

37.79888800/-122.21511300

CROSS STREET:

CHAMPION ST., S. OF PALMETTO ST.

CITY, STATE, ZIP:

OAKLAND, CA 94602

**(E) 29'-0" STEEL LIGHT POLE**

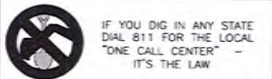

IF YOU DIG IN ANY STATE  
DIAL 811 FOR THE LOCAL  
"ONE CALL CENTER" -  
IT'S THE LAW

THE UTILITIES SHOWN HEREIN ARE FOR THE CONTRACTOR'S  
CONVENIENCE ONLY. THERE MAY BE OTHER UTILITIES NOT SHOWN  
ON THESE PLANS. THE ENGINEER/SURVEYOR ASSUMES NO  
RESPONSIBILITY FOR THE UTILITIES SHOWN AND IT SHALL BE  
THE CONTRACTOR'S RESPONSIBILITY TO VERIFY ALL THE UTILITIES  
WITHIN THE LIMITS OF THE WORK. ALL DAMAGE MADE TO THE (E)  
UTILITIES BY THE CONTRACTOR SHALL BE THE SOLE  
RESPONSIBILITY OF THE CONTRACTOR.

GENERAL NOTES

THE FACILITY IS UNMANNED AND NOT FOR HUMAN HABITATION. A  
TECHNICIAN WILL VISIT THE SITE AS REQUIRED FOR ROUTINE  
MAINTENANCE. THE PROJECT WILL NOT RESULT IN ANY SIGNIFICANT  
DISTURBANCE OF EFFECT ON DRAINAGE; NO SANITARY SEWER  
SERVICE, POTABLE WATER OR TRASH DISPOSAL IS REQUIRED AND  
NO COMMERCIAL SIGNAGE IS (N).

SITE INFORMATION

SITE ID:	9CAB013267
CASCADE ID:	SF90XS0H5B
LATITUDE:	37.79888800
LONGITUDE:	-122.21511300
CROSS STREET:	CHAMPION ST., S. OF PALMETTO ST.
CITY, STATE, ZIP:	OAKLAND, CA 94602

ALAMEDA COUNTY
CITY OF OAKLAND
PUBLIC RIGHT-OF-WAY
MOBILITIE, LLC 2955 RED HILL AVENUE, STE. 200, COSTA MESA, CA 92626 APPLICANT: JAMES SINGLETON PHONE: 805-814-0584 EMAIL: JSingleton@mobilitie.com

ENGINEER

SERVICES LVD, SUITE 1 31345	JEREMY HARMON (818) 898-2352
-----------------------------------	---------------------------------

NOT SCALE DRAWINGS

VERIFY ALL PLANS, (E) DIMENSIONS & FIELD  
JOB SITE & SHALL IMMEDIATELY NOTIFY THE  
IN WRITING OF ANY DISCREPANCIES BEFORE  
E WORK OR BE RESPONSIBLE FOR SAME.

LOCATION MAPS

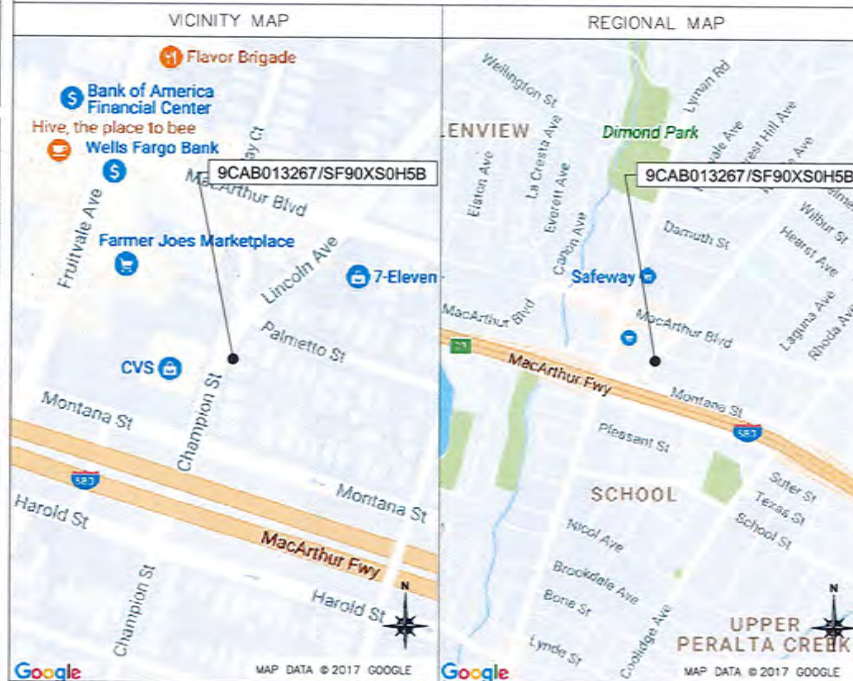

PROJECT DESCRIPTION

END USER PROPOSES TO INSTALL EQUIPMENT ON AN EXISTING  
STEEL POLE WITHIN AN EXISTING RIGHT-OF-WAY.  
THE SCOPE WILL CONSIST OF THE FOLLOWING:

- INSTALL PROPOSED SMALL SCALE WIRELESS EQUIPMENT ON AN  
EXISTING STEEL LIGHT POLE

CODES

2015 INTERNATIONAL BUILDING CODE  
2017 NATIONAL ELECTRICAL CODE  
TIA/EIA-222-G-2 OR LATEST EDITION  
LOCAL BUILDING/PLANNING CODE

DRAWING INDEX

SHEET NO:	TITLE SHEET	SHEET TITLE
T-1	TITLE SHEET	
SP-1	EXHIBIT PHOTO & SITE PLAN	
SP-2	OVERALL SITE PLAN	
EV-1	POLE ELEVATIONS	
EV-2	POLE ELEVATIONS	
PL-1	PLUMBING & RISER DIAGRAM	
EQ-1	EQUIPMENT DETAILS	
EQ-2	EQUIPMENT DETAILS	
E-1	ELECTRICAL DETAILS	
G-1	GROUNDING DETAILS	
GN-1	GENERAL NOTES	
GN-2	GENERAL NOTES	
GN-3	GENERAL NOTES	
TC-1	TRAFFIC CONTROL PLAN	



PRESCOTT COMMUNICATIONS, INC.  
10560 Southside Blvd, Suite 1, Mission Hills, CA 91345  
Phone No. (818) 258-2252 Fax No. (818) 258-0188

PROJECT NO:	9CAB013267
DRAWN BY:	DK
CHECKED BY:	JM

0	01/21/17	90% CONSTRUCTION
1	09/28/17	REVISED PER PG&E STANDARDS

IT IS A VIOLATION OF THE LAW FOR ANY  
PERSON UNLESS THEY ARE ACTING UNDER THE  
DIRECTION OF A LICENSED PROFESSIONAL  
ENGINEER, TO ALTER THIS DOCUMENT

9CAB013267  
OAKLAND, CA 94602  
(E) 29'-0" STEEL LIGHT POLE

SHEET TITLE  
TITLE SHEET

SHEET NUMBER  
T-1

EXHIBIT D

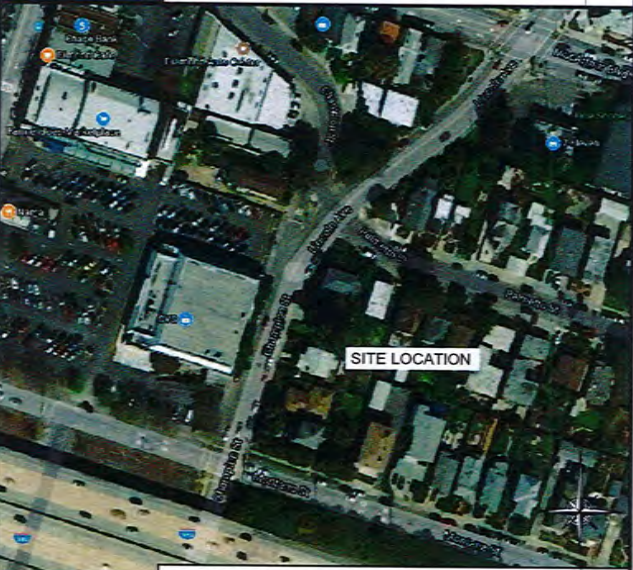



**EXHIBIT PHOTO**

SCALE: NOT TO SCALE

1



**AERIAL SITE LOCATION**

SCALE: NOT TO SCALE

2

**UNDERGROUND UTILITIES NOTE:**  
 THE LOCATIONS AND EXISTENCE OF ANY UNDERGROUND PIPES, STRUCTURES OR CONDUITS SHOWN ON THIS PLAN WERE OBTAINED BY A SEARCH OF AVAILABLE RECORDS. THERE MAY BE EX. UTILITIES OTHER THAN THOSE SHOWN ON THIS PLAN. THE CONTRACTOR IS REQUIRED TO TAKE PRECAUTIONARY MEASURES TO PROTECT THE UTILITY LINES SHOWN AND ANY OTHER LINES NOT SHOWN ON THIS PLAN.

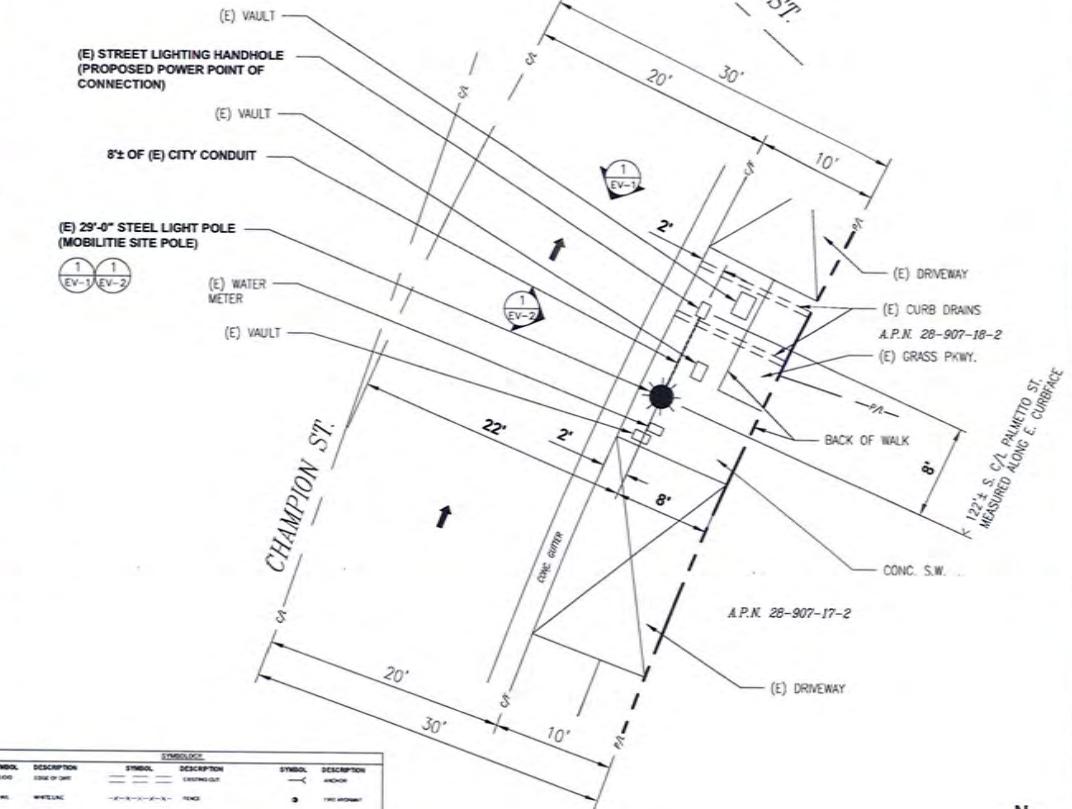

SYMBOLIC			
SYMBOL	DESCRIPTION	SYMBOL	
(Symbol)	EDGE OF LOT	(Symbol)	ANCHOR
(Symbol)	WHITE LINE	(Symbol)	TREE ANCHOR
(Symbol)	RIGHT OF WAY	(Symbol)	UTILITY VALVE
(Symbol)	EDGE OF PLUMBING	(Symbol)	UTILITY MANHOLE
(Symbol)	CONCRETE	(Symbol)	UTILITY MANHOLE
(Symbol)	CONCRETE	(Symbol)	UTILITY MANHOLE
(Symbol)	PROPERTY LINE	(Symbol)	UTILITY MANHOLE
(Symbol)	EXISTING	(Symbol)	DEGRADED
(Symbol)	NEW	(Symbol)	TRAFFIC FLAG
(Symbol)	CONDUIT CARRY OVER	(Symbol)	ADJUSTMENT
(Symbol)	SPOT ELEVATION	(Symbol)	ADJUSTMENT

**CONSTRUCTION NOTE:**  
 CONTRACTOR TO TAP IN AT THE POC AND RUN A NEW, SEPARATE CIRCUIT THROUGH CITY CONDUIT TO GO TO THE POLE.



**ENLARGED SITE PLAN**

SCALE: 1" = 10'

3



PRESOTT COMMUNICATIONS, INC.  
 10640 Sepulveda Blvd. Suite 1, Mission Hills, CA 91345  
 Phone No. (818) 259-2252 Fax No. (818) 259-0136

PROJECT NO: 9CAB013267  
 DRAWN BY: DK  
 CHECKED BY: JM

DATE	DESCRIPTION
07/21/17	90% CONSTRUCTION
08/28/17	REVISED PER PG&E STANDARDS

IT IS A VIOLATION OF THE LAW FOR ANY PERSON, UNLESS THEY ARE ACTING UNDER THE DIRECTION OF A LICENSED PROFESSIONAL ENGINEER, TO ALTER THIS DOCUMENT.

9CAB013267  
 OAKLAND, CA 94602  
 (E) 29'-0" STEEL LIGHT POLE

SHEET TITLE  
**EXHIBIT PHOTO & SITE PLAN**

SHEET NUMBER  
**SP-1**

0	01/29/17	905 CONSTRUCTION
1	09/28/17	REVISED PER PCME STANDARDS

IT IS A VIOLATION OF THE LAW FOR ANY PERSON, UNLESS THEY ARE ACTING UNDER THE DIRECTION OF A LICENSED PROFESSIONAL ENGINEER, TO ALTER THIS DOCUMENT

9CAB013267  
OAKLAND, CA 94602  
(E) 29'-0" STEEL LIGHT POLE

SHEET TITLE  
OVERALL SITE PLAN

SHEET NUMBER  
SP-2

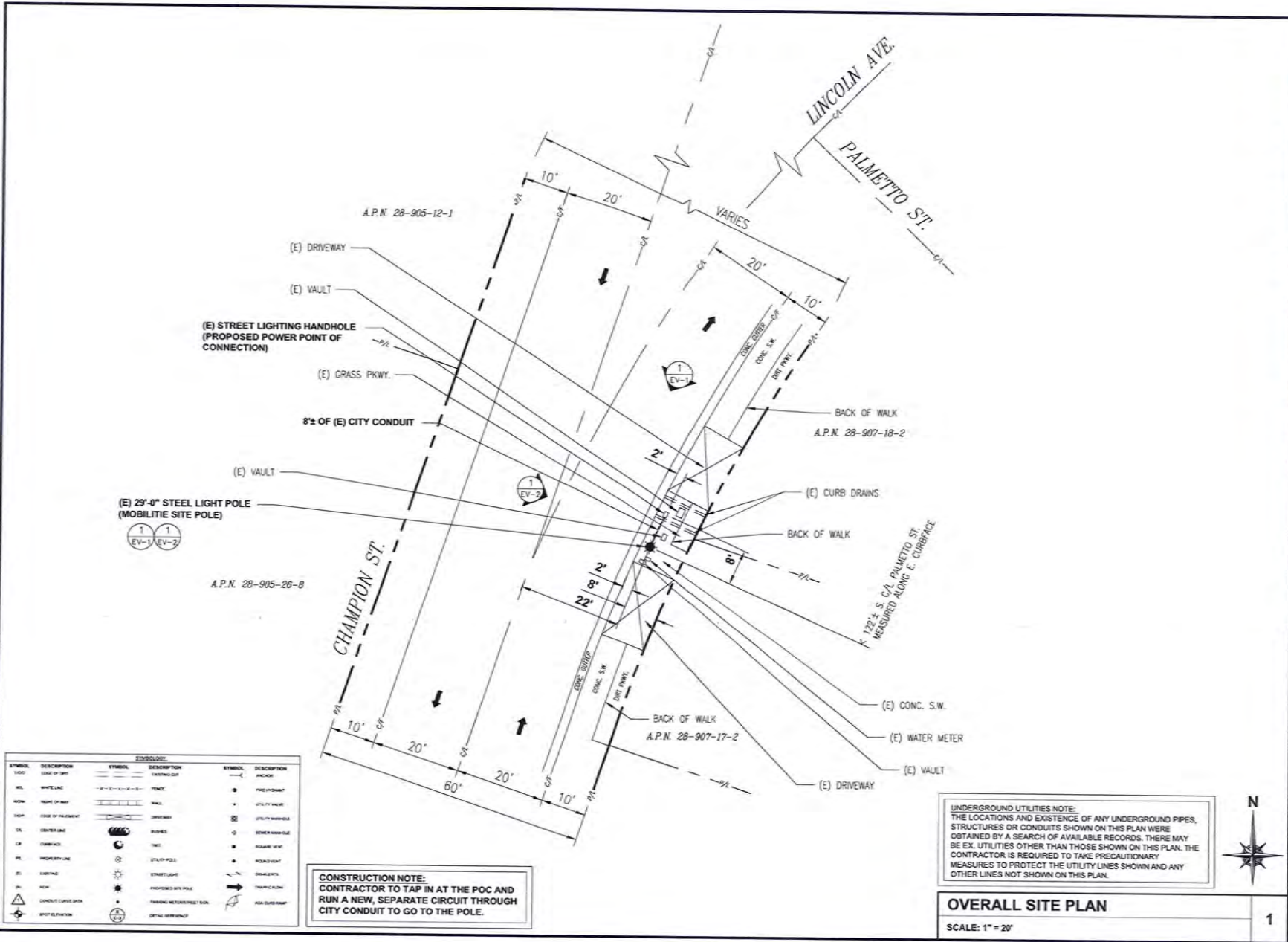

SYMBOLIC			
SYMBOL	DESCRIPTION	SYMBOL	DESCRIPTION
(Dashed line)	EDGE OF GRASS	(Circle with cross)	ANCHOR
(Dashed line)	WHITE LINE	(Circle with dot)	PIPE POINT
(Dashed line)	EDGE OF WALK	(Circle with cross-hatch)	UTILITY VALVE
(Dashed line)	EDGE OF DRIVEWAY	(Circle with cross-hatch)	UTILITY HANDHOLE
(Dashed line)	CONCRETE LADE	(Circle with cross-hatch)	SEWER HANDHOLE
(Dashed line)	CONCRETE	(Circle with cross-hatch)	SEWER VEIL
(Dashed line)	PROPERTY LINE	(Circle with cross-hatch)	ROADWAY
(Dashed line)	UTILITY POLE	(Circle with cross-hatch)	DRIVEWAY
(Dashed line)	STREET LIGHT	(Circle with cross-hatch)	TRAMPOLINE
(Dashed line)	PROPOSED WIRE POLE	(Circle with cross-hatch)	POLE/CLAMP
(Dashed line)	TRANSFORMER/STREET LIGHT	(Circle with cross-hatch)	
(Dashed line)	OPTIONAL WIRELESS	(Circle with cross-hatch)	

**CONSTRUCTION NOTE:**  
CONTRACTOR TO TAP IN AT THE POC AND RUN A NEW, SEPARATE CIRCUIT THROUGH CITY CONDUIT TO GO TO THE POLE.

**UNDERGROUND UTILITIES NOTE:**  
THE LOCATIONS AND EXISTENCE OF ANY UNDERGROUND PIPES, STRUCTURES OR CONDUITS SHOWN ON THIS PLAN WERE OBTAINED BY A SEARCH OF AVAILABLE RECORDS. THERE MAY BE EX. UTILITIES OTHER THAN THOSE SHOWN ON THIS PLAN. THE CONTRACTOR IS REQUIRED TO TAKE PRECAUTIONARY MEASURES TO PROTECT THE UTILITY LINES SHOWN AND ANY OTHER LINES NOT SHOWN ON THIS PLAN.

**OVERALL SITE PLAN**  
SCALE: 1" = 20'





PROJECT NO:	9CAB013267
DRAWN BY:	DK
CHECKED BY:	JM

0	01/29/17	90% CONSTRUCTION
1	09/28/17	REVISION PER PG&E STANDARDS

IT IS A VIOLATION OF THE LAW FOR ANY PERSON UNLESS THEY ARE ACTING UNDER THE DIRECTION OF A LICENSED PROFESSIONAL ENGINEER, TO ALTER THIS DOCUMENT

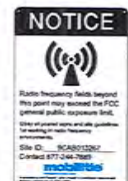

• ALL WARNING SIGNS WILL BE PAINTED TO MATCH NEW POLE.  
 • SIGN TO BE NO LARGER THAN 3'x4'.  
 • SIGN TO BE MOUNTED ON CURB SIDE.

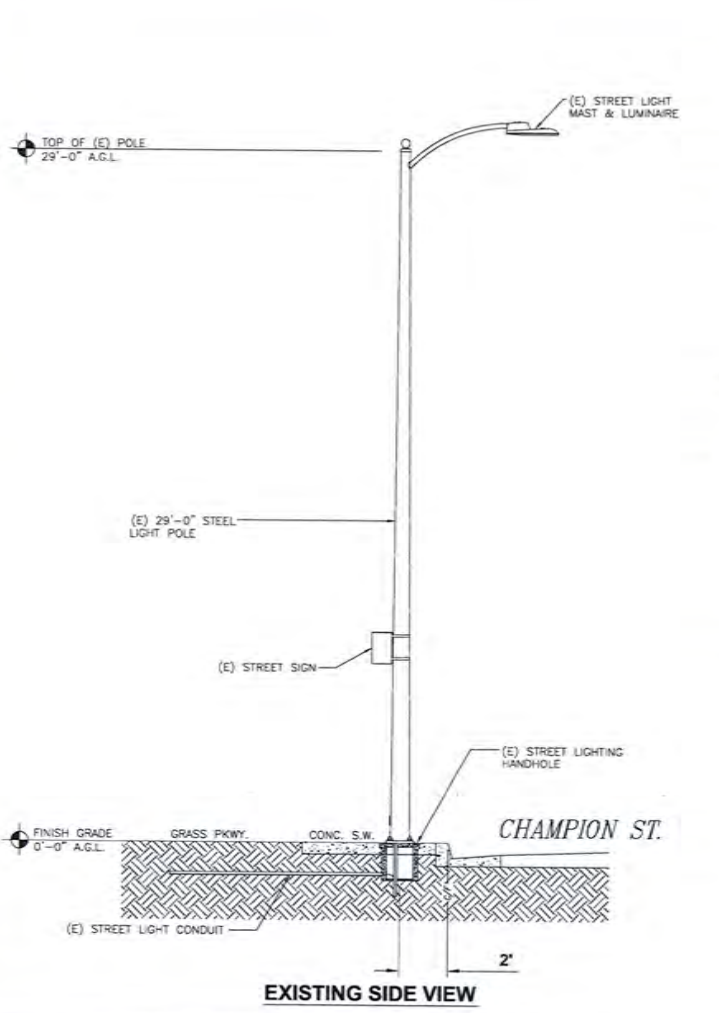
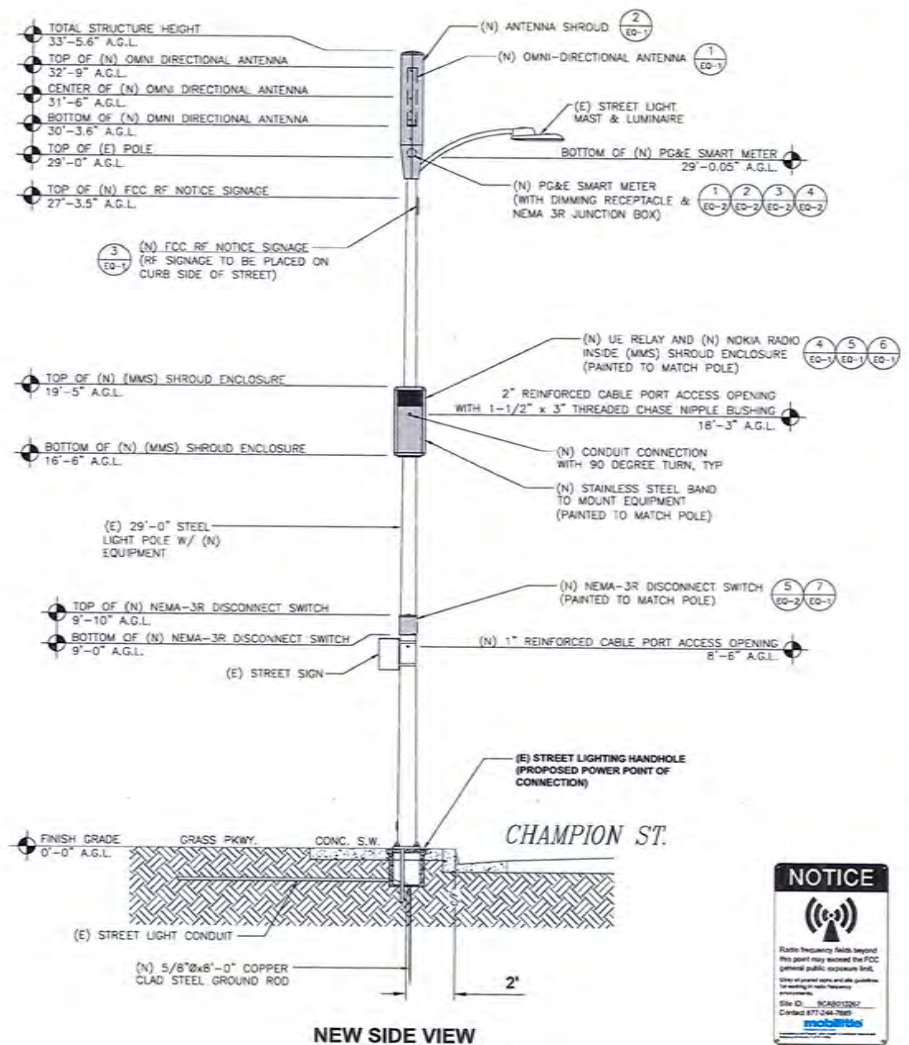

**PG&E METERING AND SERVICE CONNECTIONS FOR NON-PG&E OWNED STEEL STREETLIGHT POLES WITH ANTENNA AND COMMUNICATION EQUIPMENT**

5. A DISCONNECT SWITCH MUST BE INSTALLED AND MEETS ALL OF THE FOLLOWING REQUIREMENTS BELOW. THE SWITCH WILL BE USED AS PART OF THE NORMAL OR EMERGENCY SHUTDOWN PROTOCOLS REQUIRED IN CALIFORNIA PUBLIC UTILITY COMMISSION (CPUC) GENERAL ORDER 95, RULE 94.

5.1. THE SWITCH SHALL DE-ENERGIZE ALL POWER SUPPLIES, INCLUDING BACK-UP POWER, AND ANY COMMUNICATION EQUIPMENT EMITTING RADIO FREQUENCIES (RF).

5.2. THE SWITCH MUST NOT DE-ENERGIZE (TURN OFF) THE STREET LIGHT(S).

5.3. THE SWITCH MUST BE READILY ACCESSIBLE AND ATTACHED EXTERNALLY ON THE POLE LESS THAN 10 FEET ABOVE GRADE, AS MEASURED TO THE TOP OF THE SWITCH ENCLOSURE.

5.4. THE SWITCH MAY NOT BE INSTALLED INSIDE THE POLE, IN THE BASE OF THE POLE, OR IN A SUBSURFACE ENCLOSURE.

5.5. PROVISIONS FOR LOCKING THE DISCONNECT SWITCH IN THE OFF POSITION ARE REQUIRED.

- NOTES:**
1. ALL HARDWARE SHALL BE STAINLESS STEEL.
  2. ALL CABLES SHALL BE SECURED TO POLE EVERY 36" OR LESS.
  3. LIGHTNING RODS SHALL BE INCLUDED AS REQUIRED.
  4. STRUCTURAL BACKFILL TO BE COMPACTED IN 6" MAXIMUM LAYERS TO 95% OF CONTENT IN ACCORDANCE WITH ASTM D698. ADDITIONALLY, STRUCTURAL BACKFILL MUST HAVE A MINIMUM COMPACTED UNIT WEIGHT OF 100 POUNDS PER CUBIC FOOT (16kN/m<sup>3</sup>)

<b>POLE ELEVATIONS</b>	1
SCALE: 1" = 5'	

9CAB013267  
 OAKLAND, CA 94602  
 (E) 29'-0" STEEL LIGHT POLE

SHEET TITLE  
**POLE ELEVATIONS**

SHEET NUMBER  
**EV-1**

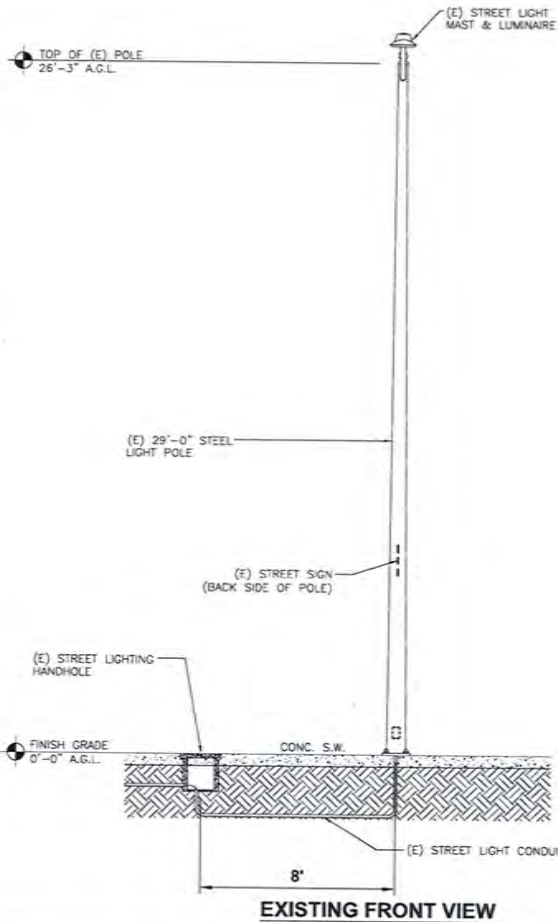

**EXISTING FRONT VIEW**

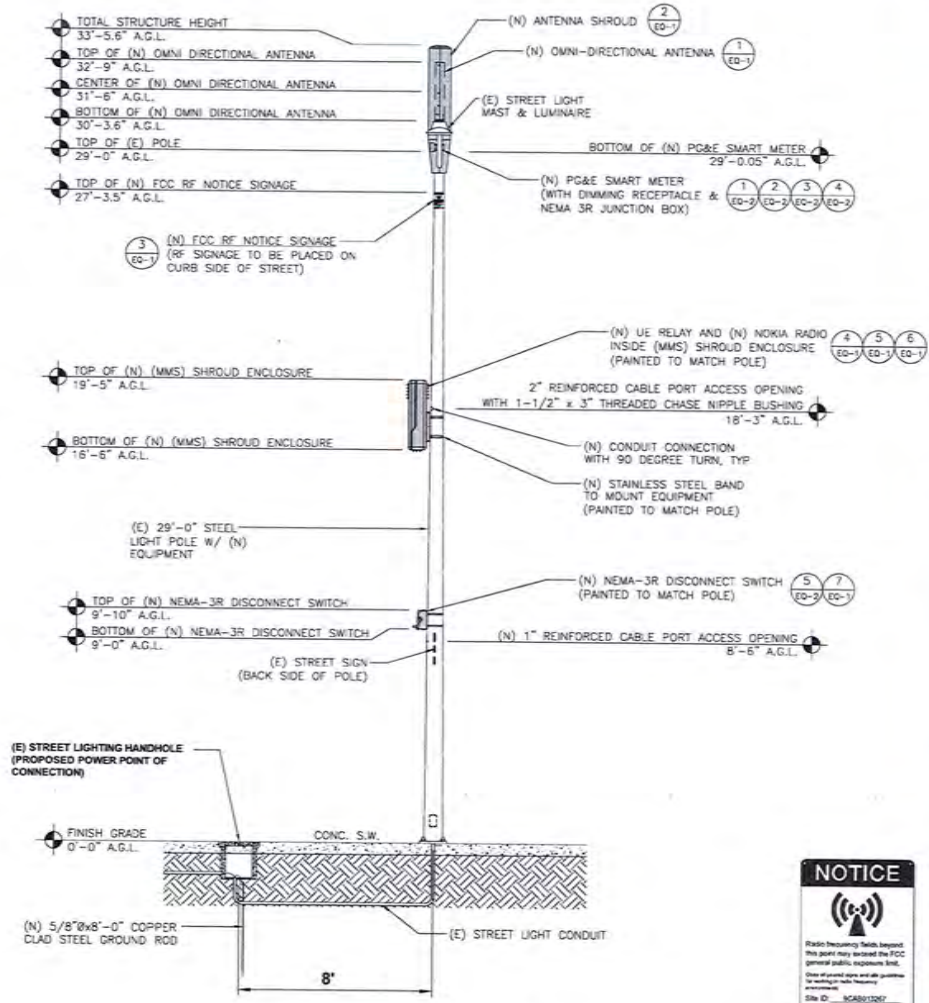

**NEW FRONT VIEW**

**PG&E METERING AND SERVICE CONNECTIONS FOR NON-PG&E OWNED STEEL STREETLIGHT POLES WITH ANTENNA AND COMMUNICATION EQUIPMENT**

5. A DISCONNECT SWITCH MUST BE INSTALLED AND MEETS ALL OF THE FOLLOWING REQUIREMENTS BELOW. THE SWITCH WILL BE USED AS PART OF THE NORMAL OR EMERGENCY SHUTDOWN PROTOCOLS REQUIRED IN CALIFORNIA PUBLIC UTILITY COMMISSION (CPUC) GENERAL ORDER 95, RULE 94.

5.1. THE SWITCH SHALL DE-ENERGIZE ALL POWER SUPPLIES, INCLUDING BACK-UP POWER, AND ANY COMMUNICATION EQUIPMENT EMITTING RADIO FREQUENCIES (RF).

5.2. THE SWITCH MUST NOT DE-ENERGIZE (TURN OFF) THE STREET LIGHT(S).

5.3. THE SWITCH MUST BE READILY ACCESSIBLE AND ATTACHED EXTERNALLY ON THE POLE LESS THAN 10 FEET ABOVE GRADE, AS MEASURED TO THE TOP OF THE SWITCH ENCLOSURE.

5.4. THE SWITCH MAY NOT BE INSTALLED INSIDE THE POLE, IN THE BASE OF THE POLE, OR IN A SUBSURFACE ENCLOSURE.

5.5. PROVISIONS FOR LOCKING THE DISCONNECT SWITCH IN THE OFF POSITION ARE REQUIRED.

**NOTES:**

1. ALL HARDWARE SHALL BE STAINLESS STEEL.
2. ALL CABLES SHALL BE SECURED TO POLE EVERY 36" OR LESS.
3. LIGHTNING RODS SHALL BE INCLUDED AS REQUIRED.
4. STRUCTURAL BACKFILL TO BE COMPACTED IN 6" MAXIMUM LAYERS TO 95% OF CONTENT IN ACCORDANCE WITH ASTM D698. ADDITIONALLY, STRUCTURAL BACKFILL MUST HAVE A MINIMUM COMPLETED UNIT WEIGHT OF 100 POUNDS PER CUBIC FOOT (16kN/m<sup>3</sup>)



- ALL WARNING SIGNS WILL BE PAINTED TO MATCH POLE COLOR.
- SIGNS TO BE NO LARGER THAN 12" X 12".
- SIGNS TO BE MOUNTED ON CURB SIDE.

<b>POLE ELEVATIONS</b>	<b>1</b>
SCALE: 1" = 5'	



**C&S cable engineering services**  
 PRESCOTT COMMUNICATIONS, INC.  
 13645 Sepulveda Blvd, Suite 1, Mission Hills, CA 91345  
 Phone No.: (818)586-2352 Fax No.: (818)586-2346

PROJECT NO:	SCAB013267
DRAWN BY:	DK
CHECKED BY:	JM

0 07/21/17	90% CONSTRUCTION
1 09/28/17	REVISED PER PG&E STANDARDS

IT IS A VIOLATION OF THE LAW FOR ANY PERSON, UNLESS THEY ARE ACTING UNDER THE DIRECTION OF A LICENSED PROFESSIONAL ENGINEER, TO ALTER THIS DOCUMENT.

SCAB013267  
 OAKLAND, CA 94602  
 (E) 29'-0" STEEL LIGHT POLE

SHEET TITLE  
**POLE ELEVATIONS**

SHEET NUMBER  
**EV-2**



**NOTE:**  
 1. CABLING DIAGRAM IS FOR CLARITY OF CABLE ROUTE AND TERMINATION ONLY. CONTRACTOR SHALL INSTALL CABLES WITH MINIMAL VISUAL IMPACT ON (E) STEEL LIGHT POLE. SEE ELEVATION DRAWING FOR EQUIPMENT AND ANTENNA LOCATIONS.

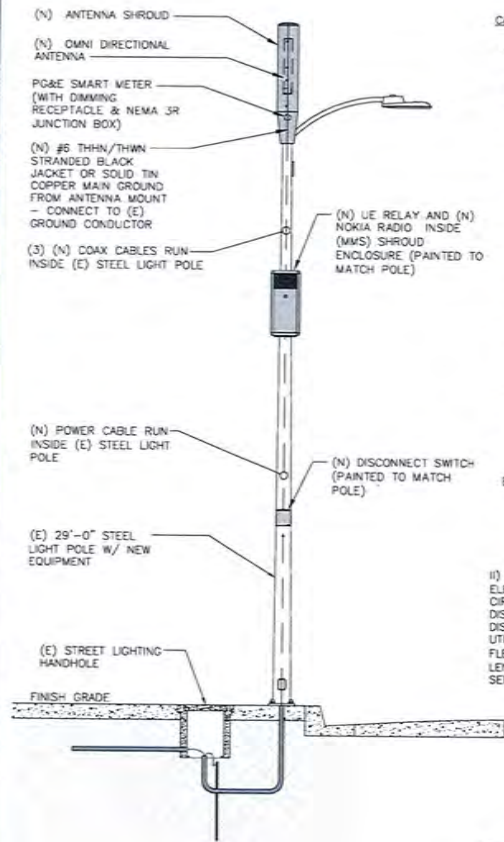

**CABLING NOTES:**

- A) WOOD, CONCRETE AND EXISTING METALLIC POLES
  - i) FROM GRADE LINE TO 11'-0" ABOVE GRADE, ALL CABLES/CONDUCTORS EXCEPT GROUNDING CONDUCTOR MUST RUN IN RIGID GALVANIZED STEEL CONDUIT (RGS)
  - ii) GROUNDING CONDUCTORS IN EXPOSED LOCATIONS MUST BE INSTALLED IN PVC.
  - iii) IN EARTH, INSTALL PVC CONDUIT FOR BACKHAUL AND ELECTRICAL SERVICE. TRANSITION TO RGS AT GRADE LINE.
  - iv) ABOVE 11'-0" ALL CABLES (POWER, ETHERNET, COAXIAL) MUST RUN IN PVC UTILITY POLE RISER.
    - (1) AT MAJOR EQUIPMENT, EXTEND UTILITY DUCT IMMEDIATELY ADJACENT TO THE EQUIPMENT. INSTALL CABLES IN THE UTILITY POLE RISER CREATING CABLE DRIP LOOPS NOT LESS THAN THE CABLE BENDING RADIUS.
    - (2) INSIDE THE UTILITY POLE RISER, UTILIZE 1/2" COAX BLOCKS WITH LAG SCREWS TO SUPPORT COAX, RADIO AND MW POWER, RF COAX, AND ETHERNET CABLES TO WITHIN 12" OF THE EQUIPMENT BEING SERVED AND ON INTERVALS NOT TO EXCEED 6'.
  - v) FOR UNDERGROUND HFC/PUBLIC BACKHAUL, ROUTE ETHERNET CABLE IN CONDUIT UP THE POLE AND ENTER THE UTILITY POLE RISER. SEAL EXPOSED END OF CONDUIT WITH A CABLE TERMINATION FITTING.
  - vi) BY APPROVAL IN SELECT CASES LIQUID-TIGHT FLEXIBLE METALLIC CONDUIT (LFMC) MAY BE USED IN LENGTHS NOT TO EXCEED 36" TO EXTEND THE ELECTRICAL SERVICE CONDUIT TO THE AC DISTRIBUTION BOX. EXAMPLE: UTILITY-REQUIRED DISCONNECT ON POLE W/ AC DISTRIBUTION BOX ON OPPOSITE SIDE OF POLE.
- B) (N) METALLIC POLES
  - i) PROCURE (N) POLES WITH SUITABLE HAND HOLES SUCH THAT HAND HOLES EXIST AT ALL EQUIPMENT LOCATIONS.
    - (1) WITH CLIENT APPROVAL IN SELECT CASES TO FACILITATE IMPROVED APPEARANCE, 1/2" COAXIAL CABLES MAY BE "SUPERFLEX" IN LIEU OF LDF-4.
  - ii) WHERE POSSIBLE, INSTALL POLE BASE SUCH THAT THE ELECTRICAL FEED AND BACKHAUL (IF UNDERGROUND) CIRCUIT ENTER THE POLE THROUGH THE POLE BASE. IF A DISCONNECTING MEANS SEPARATE FROM THE AC DISTRIBUTION BOX IS REQUIRED BY JURISDICTION OR UTILITY, WITH APPROVAL IN SELECT CASES LIQUID-TIGHT FLEXIBLE METALLIC CONDUIT (LFMC) MAY BE USED IN LENGTHS NOT TO EXCEED 36" TO EXTEND THE ELECTRICAL SERVICE CONDUIT TO THE AC DISTRIBUTION BOX.

**PLUMBING DIAGRAM**

SCALE: NOT TO SCALE

1

EQUIPMENT CHART			
QTY.	DESCRIPTION	DIMENSIONS	WEIGHT
1	ANTENNA MODEL #AW3477-S1-C (OMNI DIRECTIONAL ANTENNA)	29.5" x 4.5"φ	7 LBS
1	CONCEALFAB ANTENNA SHROUD	47.375" x 17" x 10.75"φ	16.11 LBS
1	(MMS) SHROUD ENCLOSURE	35" x 15.5" x 9"	12 LBS
1	AIRSPAN IR480 (UE RELAY)	1.3" x 7"φ	8.8 LBS
1	NOKIA RADIO (B41 FWHR) HIGH POWER	7.7" x 12.9" x 8.3"	24.64 LBS
3	FANS (2 SMALL, 1 LARGER)		2.76 LBS
1	SMART METER	2.67" x 4.5"φ	-
1	RECEPTACLE	-	-
1	ALLEN-BRADLEY NEMA 3R JUNCTION BOX	4.53" x 2.58" x 2.17"	-
1	SIEMENS DISCONNECT SWITCH MODEL #CNF321 NEMA-3R	9.9" X 8.8" X 4.5"	5 LBS
TOTAL WEIGHT			76.31 LBS

**EQUIPMENT CHART**

SCALE: NOT TO SCALE

2

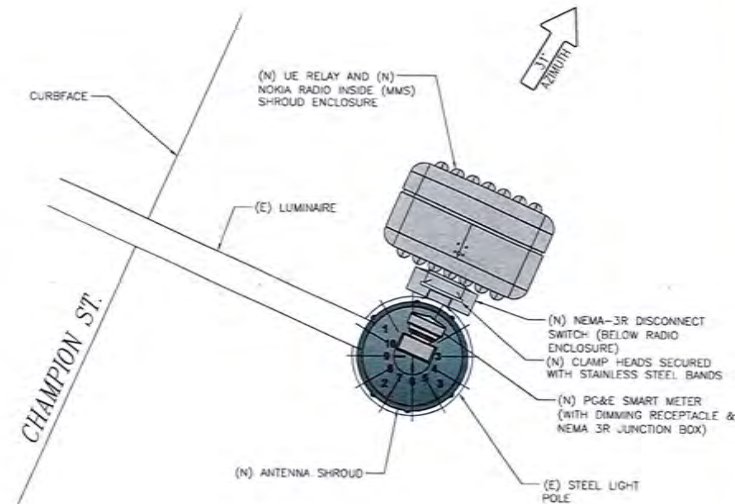

**RISER DIAGRAM**

SCALE: NOT TO SCALE

3

**mobilitie**  
 intelligent infrastructure

**C&S cable engineering services**  
 PRESCOTT COMMUNICATIONS, INC.  
 19640 Sepulveda Blvd. Suite 1, Mission Hills, CA 91345  
 Phone No. (818)928-2252 Fax No. (818)928-0185

PROJECT NO: 9CAB013267  
 DRAWN BY: DK  
 CHECKED BY: JM

DATE	DESCRIPTION
01/31/17	90% CONSTRUCTION
09/26/17	REVISED PER PC&E STANDARDS

IT IS A VIOLATION OF THE LAW FOR ANY PERSON UNLESS THEY ARE ACTING UNDER THE DIRECTION OF A LICENSED PROFESSIONAL ENGINEER, TO ALTER THIS DOCUMENT

9CAB013267  
 OAKLAND, CA 94602  
 (E) 29'-0" STEEL LIGHT POLE

SHEET TITLE  
**PLUMBING & RISER DIAGRAM**

SHEET NUMBER  
**PL-1**



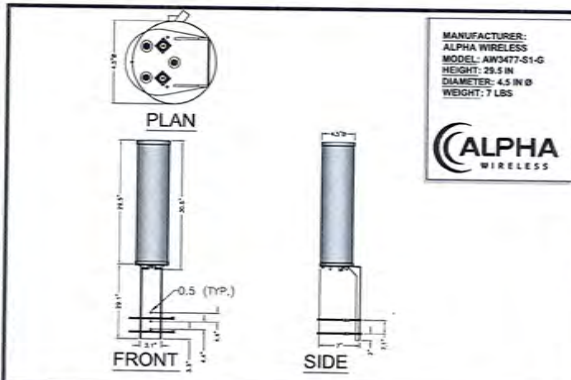

**ALPHA AW3477-S1-G OMNI (B41)** SCALE 1 N.T.S.

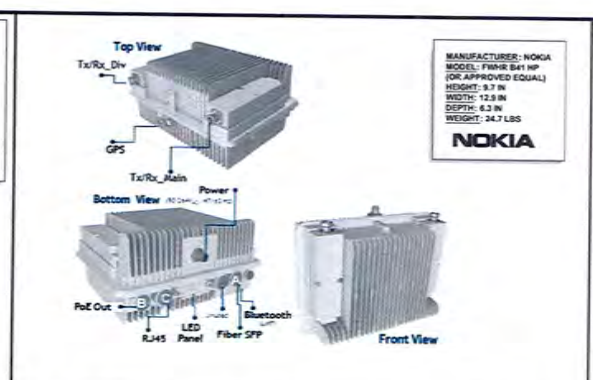

**NOKIA RADIO FWHR B41 HP** SCALE 4 N.T.S.

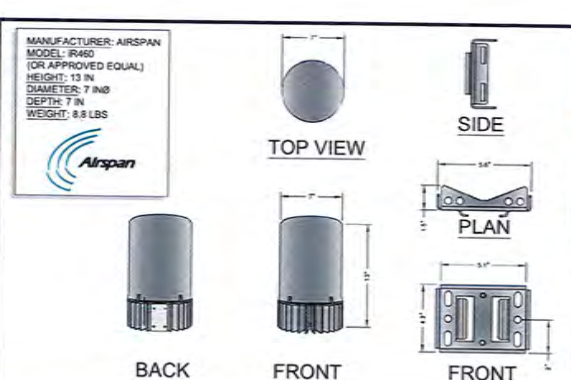

**iR460 UE RELAY/FLUSH MOUNT** SCALE 6 N.T.S.

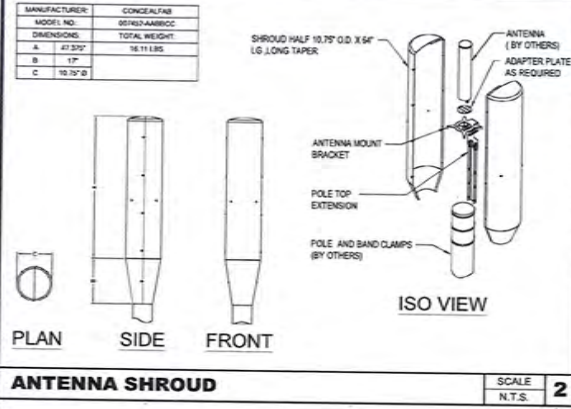

**NOTICE**

Radio frequency fields beyond this point may exceed the FCC general public exposure limit.

Obey all posted signs and site guidelines for working in radio frequency environments.

Site ID: SCAB013267  
 Contact: 877-244-7889  
**mobiltie**

**SHUT DOWN PROCEDURE SIGN**

**POLE MOUNTED SIGNS** SCALE 3 N.T.S.

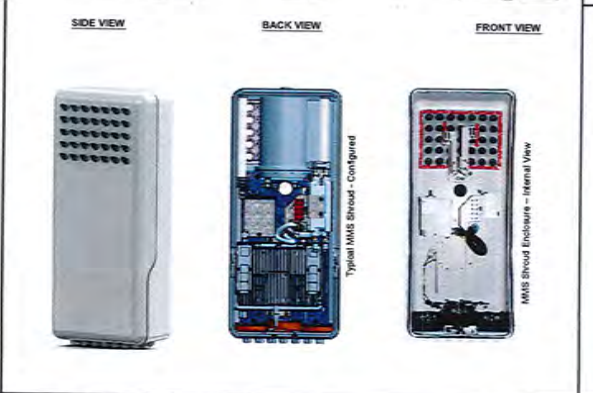
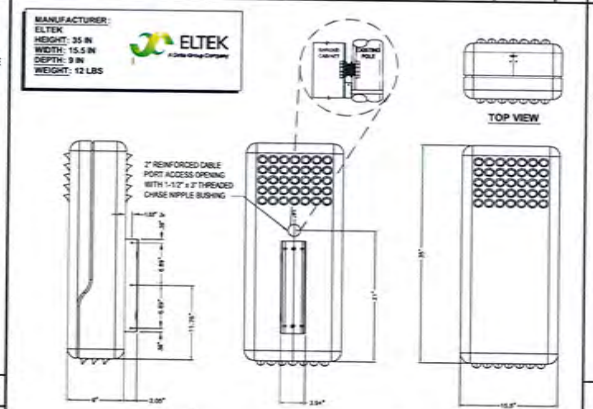

**(MMS) SHROUD ENCLOSURE** SCALE 5 N.T.S.

**mobiltie**  
 Intelligent Infrastructure

**Ces** cable engineering services  
 PRESCOTT COMMUNICATIONS, INC.  
 10645 Sepulveda Blvd, Suite 1, Mission Hills, CA 91365  
 Phone No. (818)938-2252 Fax No. (818)938-0198

PROJECT NO: 9CAB013267  
 DRAWN BY: DK  
 CHECKED BY: JM

0	07/29/17	90% CONSTRUCTION
1	09/29/17	REVISED PER POLE STANDARDS

IT IS A VIOLATION OF THE LAW FOR ANY PERSON, UNLESS THEY ARE ACTING UNDER THE DIRECTION OF A LICENSED PROFESSIONAL ENGINEER, TO ALTER THIS DOCUMENT.

9CAB013267  
 OAKLAND, CA 94602  
 (E) 29'-0" STEEL LIGHT POLE

SHEET TITLE  
**EQUIPMENT DETAILS**

SHEET NUMBER  
**EQ-1**

MANUFACTURER:  
ALLEN-BRADLEY  
MODEL: 596-85533  
HEIGHT: 4.53 IN  
WIDTH: 2.58 IN  
DEPTH: 2.17 IN  
WEIGHT: TBD

**Rockwell Automation**  
Allen-Bradley



**NEMA 3R JUNCTION BOX**

SCALE  
N.T.S. **3**

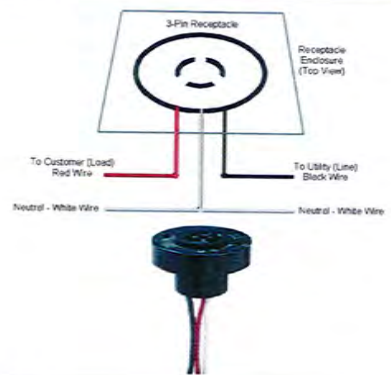

**DIMMING RECEPTACLE**

SCALE  
N.T.S. **4**

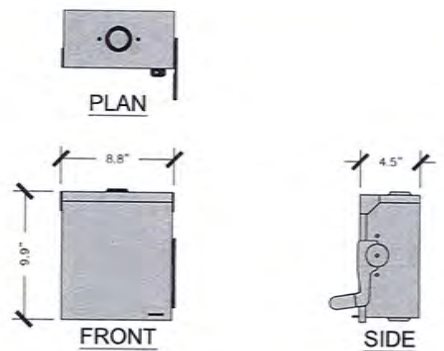

MANUFACTURER:  
SIEMENS  
MODEL: GNF321R  
(OR APPROVED EQUAL)  
HEIGHT: 9.9 IN  
WIDTH: 8.8 IN  
DEPTH: 4.5 IN  
WEIGHT: 5 LBS

**SIEMENS**

SEE DETAIL

3  
EQ-1

**NEMA-3R DISCONNECT SWITCH**

SCALE  
N.T.S. **5**



**SECTION A-A**

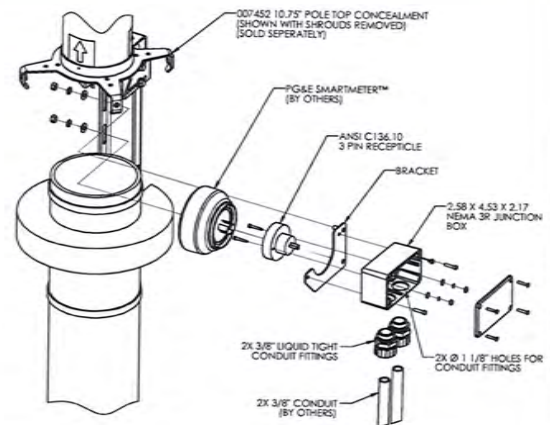
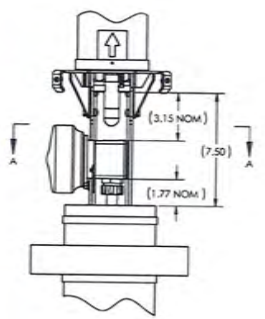

**PG&E SMART METER**

SCALE  
N.T.S. **1**

- UNIVERSAL AC INPUT 90V-305V, 50/60HZ
- AMPERE RATING: 15A MAX CONTINUOUS
- ADVANCED METERING INFRASTRUCTURE (AMI) NETWORK COMMUNICATION CARD TO REMOTELY SEND ENERGY USAGE BACK TO THE HEAD-END SYSTEM.
- DATE RATE: 50 TO 300 KBPS
- FREQUENCY RANGE: 902-928 MHz
- SPREAD SPECTRUM: FREQUENCY HOPPING
- TRANSMITTER OUTPUT: 27-30 DBM (1W)
- RECEIVER SENSITIVITY: -98 DBM FOR 10% PER
- PROTOCOL: IEEE 802.15.4G

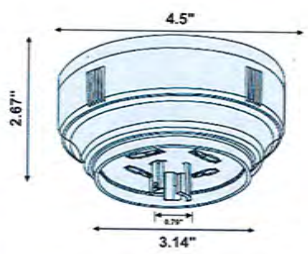

**PG&E SMART METER**

SCALE  
N.T.S. **2**



**C&S cable engineering services**  
PRESCOTT COMMUNICATIONS, INC.  
10641 Scopylands Blvd. Suite L, Mission Hills, CA 91345  
Phone No: (818)938-2352 Fax No: (818)938-1106

PROJECT NO: 9CAB013267  
DRAWN BY: DK  
CHECKED BY: JM

0	07/31/17	90% CONSTRUCTION
1	09/28/17	REVISED PER PG&E STANDARDS

IT IS A VIOLATION OF THE LAW FOR ANY PERSON UNLESS THEY ARE ACTING UNDER THE DIRECTION OF A LICENSED PROFESSIONAL ENGINEER, TO ALTER THIS DOCUMENT

9CAB013267  
OAKLAND, CA 94602  
(E) 29'-0" STEEL LIGHT POLE

SHEET TITLE  
EQUIPMENT DETAILS

SHEET NUMBER  
EQ-2



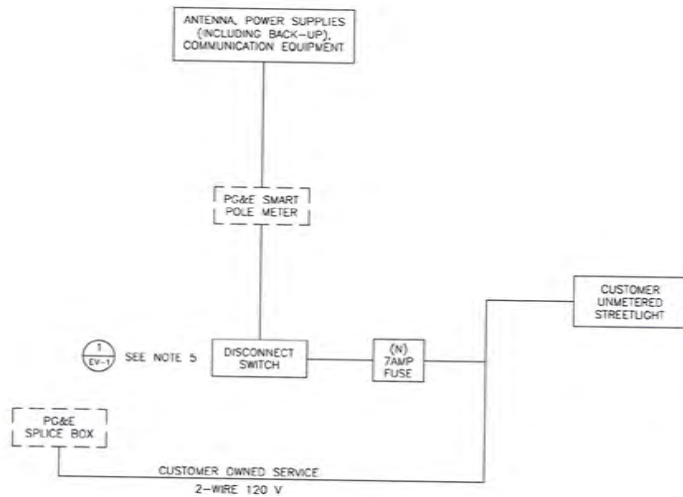

### ONE-LINE DIAGRAM

SCALE: NOT TO SCALE

1

### NOKIA MM RADIO W/ UE RELAY

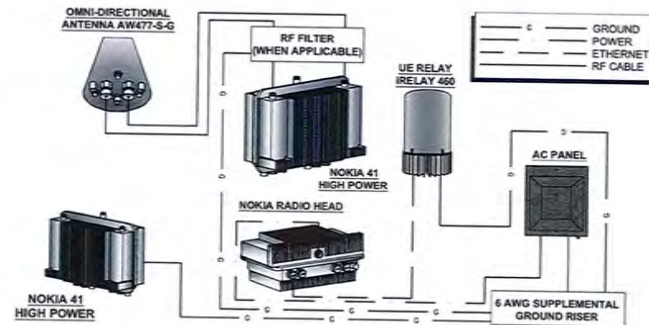

### WIRING DIAGRAM

SCALE: NOT TO SCALE

2

#### NOTES:

1. NOMINAL POWER IS CALCULATED AS 80% OF OEM DOCUMENTED MAXIMUM POWER.
2. CALCULATIONS FOR UE W/ NOKIA DO NOT NEED TO INCLUDE THE POWER FOR THE UE ANTENNA AS IT IS INCLUDED IN THE MAX POWER FIGURE. CALCULATIONS FOR UE W/ AIRSPAN MUST INCLUDE UE AS IT IS NOT INCLUDED.
3. KVA IS CALCULATED FROM THE CONSUMPTION VALUE ASSUMING A PF=1. MAXIMUM POWER WAS USED FOR KVA. WHERE MAXIMUM WAS NOTED BY THE OEM THE QUOTED FIGURE WAS USED. WHERE AVERAGE/NOMINAL POWER WAS NOTED BY THE OEM MAXIMUM POWER WAS CALCULATED BY INCREASING AVERAGE/NOMINAL POWER BY A FACTOR OF 50%.
4. COST PER KW PROVIDED BY BRAIN KOOYMAN.

NOKIA SCENARIO 3 B41 HIGH POWER RADIO AND UE BACKHAUL									
UNIT	SUB DESCRIPTION	MAX POWER	NOMINAL POWER	AVERAGE POWER (W)	CONS. (W)	KVA	KWH/YR	\$/YR	\$/MO
FWHR	B41 High	360	288	N/A	288	0.36	2522.88	\$276.51	\$23.04
AIRSPAN UE RELAY	IR460-SPB-ST1-P-0	N/A	N/A	N/A	0	0	0	\$-	\$-
TOTAL						288	2522.88	\$276.51	\$23.04

### LOAD CALCULATIONS

SCALE: NOT TO SCALE

3

**mobilitie**  
intelligent infrastructure

**C&S** cable engineering services

PRESCOTT COMMUNICATIONS INC.  
10640 Squimada Blvd, Suite 1, Mission Hill, CA 94602  
Phone No: (916) 939-2302 Fax No: (916) 939-1936

PROJECT NO: 9CAB013267

DRAWN BY: DK

CHECKED BY: JM

REV	DATE	DESCRIPTION
0	07/28/17	REV CONSTRUCTION
1	08/28/17	REVISED PER PG&E STANDARDS

IT IS A VIOLATION OF THE LAW FOR ANY PERSON, UNLESS THEY ARE ACTING UNDER THE DIRECTION OF A LICENSED PROFESSIONAL ENGINEER, TO ALTER THIS DOCUMENT.

9CAB013267  
OAKLAND, CA 94602  
(E) 29'-0" STEEL LIGHT POLE

SHEET TITLE  
ELECTRICAL DETAILS

SHEET NUMBER  
E-1

NOTE:  
CONTRACTOR TO SURROUND COMPLETED CONNECTION WITH HEAT-SHRINK TUBING TO ENSURE WEATHER PROOF CONNECTION

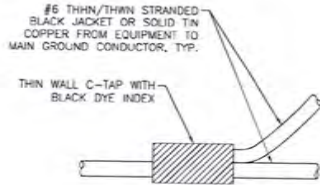

**C-TAP DETAIL**

SCALE: NOT TO SCALE

1

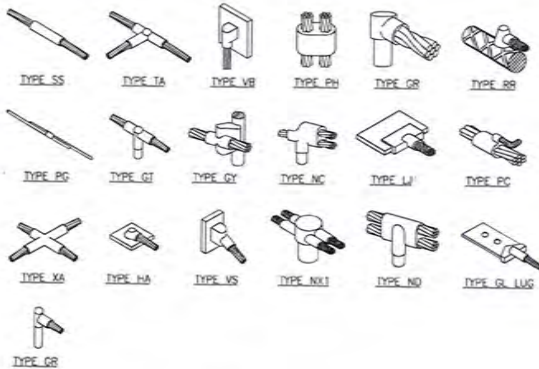

1. **GROUNDING BONDS:** ALL BONDS ARE TO BE MADE WITH #2 AWG STRANDED COPPER IN GREEN INSULATION. (ATT-TP-76416 7, 6.7)
2. **EXTERIOR UNIT BONDS:** ALL METALLIC OBJECTS SHALL BE BONDED TO THE GROUND ROD. (ATT-TP-76416 7, 12.6)
3. **GROUND ROD:** UL LISTED COPPER CLAD STEEL GROUND ROD WITH MINIMUM DIAMETER OF 5/8" AND MINIMUM LENGTH OF 8 FEET. ALL GROUND RODS MAY BE INSTALLED WITH INSPECTION SLEEVES. GROUND RODS SHALL BE DRIVEN TO A MINIMUM DEPTH OF 30" BELOW GRADE OR 6 INCHES BELOW FROST LINE. (ATT-TP-76416 1.4 / 2.2, 3, 10)

**WELD CONNECTION DETAILS**

SCALE: NOT TO SCALE

2

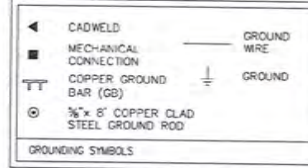
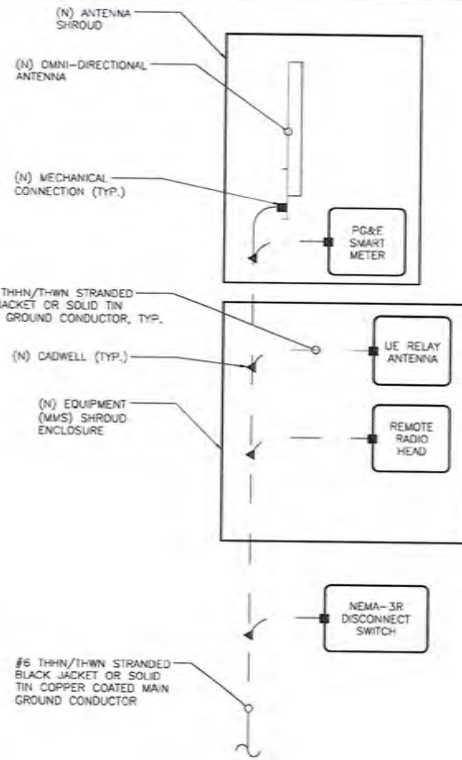

- NOTES:**
1. GROUNDING RISER FOR DIAGRAMMATIC PURPOSES ONLY. SEE ELEVATION DRAWING FOR EQUIPMENT AND ANTENNA LOCATIONS.
  2. ALL RODS TO BE GROUND AT BOTH ENDS USING GROUNDING BUSHINGS
  3. GROUND WIRE BELOW 11' AGL TO BE RUN IN 1/2" SCHEDULE 40 PVC.

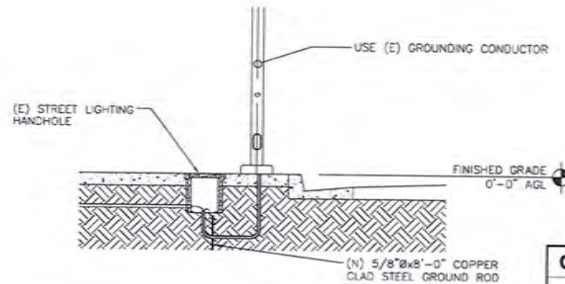

**GROUNDING RISER DIAGRAM**

SCALE: NOT TO SCALE

3

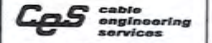

PRESCOTT COMMUNICATIONS INC.  
10640 Sepulveda Blvd. Suite 1, Mission Hills, CA 91345  
Phone No. (818)266-2252 Fax No. (818)266-0168

PROJECT NO: 9CAB013267  
DRAWN BY: DK  
CHECKED BY: JM

0	01/25/17	925 CONSTRUCTION
1	09/29/17	REVISED PER PG&E STANDARDS

IT IS A VIOLATION OF THE LAW FOR ANY PERSON, UNLESS THEY ARE ACTING UNDER THE DIRECTION OF A LICENSED PROFESSIONAL ENGINEER, TO ALTER THIS DOCUMENT

9CAB013267  
OAKLAND, CA 94602  
(E) 29'-0" STEEL LIGHT POLE

SHEET TITLE  
**GROUNDING DETAILS**

SHEET NUMBER  
**G-1**



**GENERAL CONSTRUCTION NOTES:**

1. ALL WORK SHALL CONFORM TO THE REQUIREMENTS OF THE LOCAL BUILDING CODE, THE LATEST ADOPTED EDITION AND ALL OTHER APPLICABLE CODES AND ORDINANCES.
2. CONTRACTOR SHALL CONSTRUCT SITE IN ACCORDANCE WITH THESE DRAWINGS AND LATEST MOBILITE CONSTRUCTION STANDARDS. THE SPECIFICATION IS THE RULING DOCUMENT AND ANY DISCREPANCIES BETWEEN THE SPECIFICATION AND THE CONSTRUCTION DRAWINGS SHALL BE BROUGHT TO THE ATTENTION OF THE ARCHITECT/ENGINEER OR MOBILITE CM PRIOR TO THE COMMENCEMENT OF WORK.
3. CONTRACTOR SHALL VISIT THE JOB SITE AND SHALL FAMILIARIZE THEMSELVES WITH ALL CONDITIONS AFFECTING THE (N) WORK AND SHALL MAKE PROVISIONS AS TO THE COST THEREOF. CONTRACTOR SHALL BE RESPONSIBLE FOR FAMILIARIZING THEMSELVES WITH ALL CONTRACT DOCUMENTS, FIELD CONDITIONS AND DIMENSIONS AND CONFIRMING THAT THE WORK MAY BE ACCOMPLISHED, AS SHOWN, PRIOR TO PROCEEDING WITH CONSTRUCTION. ANY DISCREPANCIES SHALL BE BROUGHT TO THE ATTENTION OF THE ARCHITECT/ENGINEER OR MOBILITE CM PRIOR TO THE COMMENCEMENT OF WORK. NO COMPENSATION WILL BE AWARDED BASED ON CLAIM OF LACK OF KNOWLEDGE OF FIELD CONDITIONS.
4. IT IS NOT THE INTENT OF THESE PLANS TO SHOW EVERY MINOR DETAIL OF CONSTRUCTION. CONTRACTOR IS REQUIRED TO FURNISH AND INSTALL ANY/ALL ITEMS FOR A COMPLETE AND FULLY FUNCTIONAL SYSTEM SUBJECT ONLY TO OWNER-SUPPLIED ITEMS. CONTRACTOR SHALL PROVIDE ANY/ALL REQUIREMENTS FOR THE EQUIPMENT TO BE PLACED IN PROPER WORKING ORDER.
5. PLANS ARE NOT TO BE SCALED. THESE PLANS ARE INTENDED TO BE A DIAGRAMMATIC OUTLINE ONLY UNLESS OTHERWISE NOTED. THE WORK SHALL INCLUDE FURNISHING MATERIALS, EQUIPMENT AND APPURTENANCES, AND LABOR NECESSARY TO EFFECT ALL INSTALLATIONS AS INDICATED ON THE DRAWINGS. OWNER PROVIDED MATERIALS WILL INCLUDE THOSE ITEMS LISTED IN THE EQUIPMENT DETAILS SECTION OF THESE DRAWINGS UNLESS OTHERWISE SPECIFIED OR PROVIDED TO THE CONTRACTOR IN WRITING PRIOR TO CONSTRUCTION START.
6. DIMENSIONS SHOWN ARE TO FINISH SURFACES UNLESS OTHERWISE NOTED. SPACING BETWEEN EQUIPMENT IS REQUIRED CLEARANCE. THEREFORE, IT IS CRITICAL TO FIELD VERIFY DIMENSIONS. SHOULD THERE BE ANY QUESTIONS REGARDING THE CONTRACT DOCUMENTS, (E) CONDITIONS AND/OR DESIGN INTENT, THE CONTRACTOR SHALL BE RESPONSIBLE FOR REPORTING ANY DISCREPANCIES TO THE ATTENTION OF THE MOBILITE CM, IN WRITING, PRIOR TO THE COMMENCEMENT OF WORK.
7. DETAILS PROVIDED ARE FOR THE PURPOSE OF SHOWING DESIGN INTENT. MODIFICATIONS MAY BE REQUIRED TO SUIT JOB DIMENSIONS OR SITE CONDITIONS, AND SUCH MODIFICATIONS SHALL BE INCLUDED AS PART OF THE WORK.
8. CONTRACTOR SHALL PAY FOR APPLICABLE PERMITS, FEES, INSPECTIONS AND TESTING, CONTRACTOR IS TO OBTAIN PERMITS AND APPROVED SUBMITTALS PRIOR TO ORDERING MATERIALS AND THE COMMENCEMENT OF WORK.
9. THE TERM "PROVIDE" USED IN CONSTRUCTION DOCUMENTS AND SPECIFICATIONS, INDICATES THAT THE CONTRACTOR SHALL FURNISH AND INSTALL.
10. CONTRACTOR SHALL RECEIVE CLARIFICATION IN WRITING, AND SHALL RECEIVE IN WRITING AUTHORIZATION TO PROCEED BEFORE STARTING WORK ON ANY ITEMS NOT CLEARLY DEFINED OR IDENTIFIED BY THE CONTRACT DOCUMENTS.
11. CONTRACTOR SHALL SUPERVISE AND DIRECT THE WORK USING ACCEPTED INDUSTRY-STANDARD SKILLS AND ATTENTION. CONTRACTOR SHALL BE SOLELY RESPONSIBLE FOR CONSTRUCTION MEANS, METHODS, TECHNIQUES, SEQUENCES AND PROCEDURES AND FOR COORDINATING ALL PORTIONS OF THE WORK UNDER CONTRACT, UNLESS OTHERWISE NOTED.
12. CONTRACTOR SHALL BE RESPONSIBLE FOR THE SAFETY OF THE WORK AREA, ADJACENT AREAS AND BUILDING OCCUPANTS THAT ARE LIKELY TO BE AFFECTED BY THE WORK UNDER THIS CONTRACT. WORK SHALL CONFORM TO ALL OSHA REQUIREMENTS.
13. CONTRACTOR SHALL COORDINATE THEIR WORK WITH THE MOBILITE CM AND SCHEDULE THEIR ACTIVITIES AND WORKING HOURS IN ACCORDANCE WITH THE REQUIREMENTS.

14. CONTRACTOR SHALL BE RESPONSIBLE FOR COORDINATING THEIR WORK WITH THE WORK OF OTHERS AS IT MAY RELATE TO RADIO EQUIPMENT, ANTENNAS AND ANY OTHER PORTIONS OF THE WORK.
15. CONTRACTOR SHALL INSTALL ALL EQUIPMENT AND MATERIALS IN ACCORDANCE WITH MANUFACTURERS RECOMMENDATIONS UNLESS SPECIFICALLY OTHERWISE INDICATED OR WHERE LOCAL CODES OR REGULATIONS TAKE PRECEDENCE.
16. CONTRACTOR SHALL MAKE NECESSARY PROVISIONS TO PROTECT (E) SURFACES, EQUIPMENT, IMPROVEMENTS, PIPING ETC. AND IMMEDIATE REPAIR, TO NEW CONDITION, ANY DAMAGE THAT OCCURS DURING CONSTRUCTION AT THE SOLE COST OF THE CONTRACTOR.
17. IN DRILLING HOLES, OR CORING, INTO CONCRETE WHETHER FOR FASTENING OR ANCHORING PURPOSES, OR PENETRATIONS THROUGH THE FLOOR FOR CONDUIT RUNS, PIPE RUNS, ETC., MUST BE CLEARLY UNDERSTOOD THAT REINFORCING STEEL SHALL NOT BE DRILLED INTO, CUT OR DAMAGED UNDER ANY CIRCUMSTANCES (UNLESS NOTED OTHERWISE). LOCATIONS OF REINFORCING STEEL ARE NOT DEFINITELY KNOWN AND THEREFORE MUST BE LOCATED BY THE CONTRACTOR USING APPROPRIATE METHODS AND EQUIPMENT PRIOR TO ANY DRILLING OR CORING OPERATIONS IN (E) CONCRETE.
18. CONTRACTOR SHALL REPAIR, TO NEW CONDITION, ALL (E) WALL SURFACES DAMAGED DURING CONSTRUCTION SUCH THAT THEY MATCH AND BLEND IN WITH ADJACENT SURFACES.
19. CONTRACTOR SHALL SEAL PENETRATIONS THROUGH FIRE RATED ASSEMBLIES OR MATERIALS WITH U.L. LISTED AND FIRE CODE APPROVED MATERIALS AND SYSTEMS THAT MEET OR EXCEED THE RATING OF THE ASSEMBLY IN WHICH THE NEW PENETRATION IS PLACED.
20. CONTRACTOR SHALL KEEP CONTRACT AREA CLEAN, HAZARD FREE, AND DISPOSE OF ALL DIRT, DEBRIS, AND RUBBISH. EQUIPMENT NOT SPECIFIED AS REMAINING ON THE PROPERTY OF THE OWNER SHALL BE REMOVED. LEAVE PREMISES IN CLEAN CONDITION AND FREE FROM PAINT SPOTS, DUST, OR SMUDGES OF ANY NATURE. CONTRACTOR SHALL BE RESPONSIBLE FOR MAINTAINING ALL ITEMS UNTIL COMPLETION OF CONSTRUCTION.
21. MINIMUM BEND RADIUS OF ANTENNA CABLES SHALL BE IN ACCORDANCE WITH CABLE MANUFACTURERS RECOMMENDATIONS.
22. CONTRACTOR SHALL MINIMIZE DISTURBANCE TO (E) SITE DURING CONSTRUCTION. EROSION CONTROL MEASURES, IF REQUIRED DURING CONSTRUCTION SHALL BE IN CONFORMANCE WITH JURISDICTIONAL OR STATE AND LOCAL GUIDELINES FOR EROSION AND SEDIMENT CONTROL AND COORDINATED WITH LOCAL REGULATORY AUTHORITIES. CONTRACTOR SHALL BE RESPONSIBLE FOR MAINTENANCE OF ANY EROSION CONTROL MEASURES, RECORD-KEEPING, MONITORING, AND REPORTING TO THE OWNER AND REGULATORY AUTHORITIES.
23. ALL CONSTRUCTION WORK IS TO ADHERE TO APPLICANT'S INTEGRATED CONSTRUCTION STANDARDS UNLESS STATE OR LOCAL CODE IS MORE STRINGENT.
24. THE INTENT OF THE PLANS AND SPECIFICATIONS IS TO PERFORM THE CONSTRUCTION IN ACCORDANCE PER STATE BUILDING STANDARDS CODE AND STATE CODE OF REGULATIONS, SHOULD ANY CONDITIONS DEVELOP NOT COVERED BY THE APPROVED PLANS AND SPECIFICATIONS WHEREIN THE FINISHED WORK WILL NOT COMPLY PER STATE CODE OF REGULATIONS, A SCOPE OF WORK DETAILING AND SPECIFYING THE REQUIRED WORK SHALL BE SUBMITTED TO AND APPROVED BY THE JURISDICTION BEFORE PROCEEDING WITH THE WORK. A CHANGE ORDER FOR THAT SCOPE SHALL BE SUBMITTED TO THE MOBILITE CM PRIOR TO PROCEEDING WITH THE WORK.
25. ADEQUATE AND REQUIRED LIABILITY INSURANCE SHALL BE PROVIDED BY THE CONTRACTOR FOR PROTECTION AGAINST PUBLIC LOSS AND ANY/ALL PROPERTY DAMAGE FOR THE DURATION OF WORK.
26. CONTRACTOR SHALL GUARANTEE ANY/ALL MATERIALS AND WORK FREE FROM DEFECTS FOR A PERIOD OF NOT LESS THAN ONE YEAR FROM DATE OF ACCEPTANCE. ANY CORRECTIVE WORK SHALL BE COMPLETED AT THE SOLE COST OF THE CONTRACTOR.
27. CONTRACTOR TO TAP IN AT THE POC AND RUN A NEW, SEPARATE CIRCUIT THROUGH CITY CONDUIT TO GO TO THE POLE.

**ELECTRICAL NOTES:**

1. ELECTRICAL CONTRACTOR SHALL SUPPLY AND INSTALL ANY/ALL ELECTRICAL WORK INDICATED. ANY/ALL CONSTRUCTION SHALL BE IN ACCORDANCE WITH DRAWINGS AND ANY/ALL APPLICABLE SPECIFICATIONS. IF ANY PROBLEMS ARE ENCOUNTERED BY COMPLYING WITH THESE REQUIREMENTS, CONTRACTOR SHALL NOTIFY MOBILITE CM AS SOON AS POSSIBLE, AFTER THE DISCOVERY OF THE PROBLEMS, AND SHALL NOT PROCEED WITH THAT PORTION OF WORK, UNTIL THE MOBILITE CM HAS DIRECTED THE CORRECTIVE ACTIONS TO BE TAKEN.
2. ELECTRICAL CONTRACTOR SHALL VISIT THE JOB SITE AND FAMILIARIZE THEMSELVES WITH ANY/ALL CONDITIONS AFFECTING ELECTRICAL AND COMMUNICATION INSTALLATION AND MAKE PROVISIONS AS TO THE COST THEREOF. ALL (E) CONDITIONS OF ELECTRICAL EQUIP., ETC., THAT ARE PART OF THE FINAL SYSTEM, SHALL BE VERIFIED BY THE CONTRACTOR, PRIOR TO THE SUBMITTING OF THEIR BID. FAILURE TO COMPLY WITH THIS PARAGRAPH WILL IN NO WAY RELIEVE CONTRACTOR OF PERFORMING ALL WORK NECESSARY FOR A COMPLETE AND WORKING SYSTEM.
3. ALL WORK SHALL BE PERFORMED IN ACCORDANCE WITH THE LATEST EDITION OF THE NEC, ALL CODES AND ORDINANCES OF THE LOCAL JURISDICTION, AND POWER & TELEPHONE COMPANIES HAVING JURISDICTION AND SHALL INCLUDE BUT ARE NOT BE LIMITED TO:
  - A) UL - UNDERWRITERS LABORATORIES
  - B) NEC - NATIONAL ELECTRICAL CODE
  - C) NEMA - NATIONAL ELECTRICAL MANUFACTURERS ASSOC.
  - D) OSHA - OCCUPATIONAL SAFETY AND HEALTH ACT
  - E) SBC - STANDARD BUILDING CODE
  - F) NFPA - NATIONAL FIRE PROTECTION AGENCY
  - G) ANSI - AMERICAN NATIONAL STANDARDS INSTITUTE
  - H) IEEE - INSTITUTE OF ELECTRICAL AND ELECTRONICS ENGINEERS
  - I) ASTM - AMERICAN SOCIETY FOR TESTING MATERIALS
4. REFER TO SITE PLANS AND ELEVATIONS FOR EXACT LOCATIONS OF ALL EQUIPMENT, AND CONFIRM WITH MOBILITE CM ANY SIZES AND LOCATIONS WHEN NEEDED.
5. (E) SERVICES: CONTRACTOR SHALL NOT INTERRUPT (E) SERVICES WITHOUT WRITTEN PERMISSION OF THE OWNER.
6. CONTRACTOR SHALL CONFIRM WITH LOCAL UTILITY COMPANY ANY/ALL REQUIREMENTS SUCH AS THE LOG SIZE RESTRICTIONS, CONDUIT ENTRY, SIZE OF TRANSFORMERS, SCHEDULED DOWNTIME FOR THE OWNERS' CONFIRMATION, ETC.. ANY/ALL CONFLICTS SHALL BE BROUGHT TO THE ATTENTION OF THE MOBILITE CM, PRIOR TO BEGINNING ANY WORK.
7. MINIMUM WIRE SIZE SHALL BE #12 AWG, NOT INCLUDING CONTROL WIRING, UNLESS NOTED OTHERWISE. ALL CONDUCTORS SHALL BE COPPER WITH THIN INSULATION, UNLESS OTHERWISE NOTED.
8. OUTLET BOXES SHALL BE PRESSED STEEL IN DRY LOCATIONS, CAST ALLOY WITH THREADED HUBS IN WET/DAMP LOCATIONS AND SPECIAL ENCLOSURES FOR OTHER CLASSIFIED AREAS.
9. IT IS NOT THE INTENT OF THESE PLANS TO SHOW EVERY MINOR DETAIL OF THE CONSTRUCTION. CONTRACTOR IS EXPECTED TO FURNISH AND INSTALL ALL ITEMS FOR A COMPLETE ELECTRICAL SYSTEM AND PROVIDE ALL REQUIREMENTS FOR THE EQUIPMENT TO BE PLACED IN PROPER WORKING ORDER.
10. ELECTRICAL SYSTEM SHALL BE AS COMPLETELY AND EFFECTIVELY GROUNDED, AS REQUIRED BY SPECIFICATIONS, SET FORTH BY APPLICANT.
11. ALL WORK SHALL BE PERFORMED BY A LICENSED ELECTRICAL CONTRACTOR IN A FIRST CLASS, WORKMANLIKE MANNER. THE COMPLETED SYSTEM SHALL BE FULLY FUNCTIONAL AND SHALL BE APPROVED BY THE MOBILITE CM AND LOCAL JURISDICTION. ANY DEFICIENCIES SHALL BE CORRECTED BY AN ELECTRICAL CONTRACTOR AT THE SOLE COST OF THE CONTRACTOR.
12. ALL WORK SHALL BE COORDINATED WITH OTHER TRADES TO AVOID INTERFERENCE WITH THE PROGRESS OF CONSTRUCTION.



PROJECT NO: 9CAB013267  
 DRAWN BY: DK  
 CHECKED BY: JM

0	07/31/17	SDC CONSTRUCTION
1	09/26/17	REVISED PER PG&E STANDARDS

IT IS A VIOLATION OF THE LAW FOR ANY PERSON, UNLESS THEY ARE ACTING UNDER THE DIRECTION OF A LICENSED PROFESSIONAL ENGINEER, TO ALTER THIS DOCUMENT.

9CAB013267  
 OAKLAND, CA 94602  
 (E) 29'-0" STEEL LIGHT POLE

SHEET TITLE  
 GENERAL NOTES

SHEET NUMBER  
 GN-1



ELECTRICAL NOTES CONT'D

13. THE CORRECTION OF ANY DEFECTS SHALL BE COMPLETED BY THE CONTRACTOR WITHOUT ANY ADDITIONAL CHARGE AND SHALL INCLUDE THE REPLACEMENT OR THE REPAIR OF ANY OTHER PHASE OF THE INSTALLATION, WHICH MAY HAVE BEEN DAMAGED THEREIN.
14. CONTRACTOR SHALL PROVIDE AND INSTALL CONDUIT, CONDUCTORS, PULL WIRES, BOXES, COVER PLATES AND DEVICES FOR ALL OUTLETS AS INDICATED.
15. DITCHING AND BACK FILL: CONTRACTOR SHALL PROVIDE FOR ALL UNDERGROUND INSTALLED CONDUIT AND/OR CABLES INCLUDING EXCAVATION AND BACKFILLING AND COMPACTION. REFER TO NOTES AND REQUIREMENTS EXCAVATION, AND BACKFILLING.
16. MATERIALS, PRODUCTS AND EQUIPMENT, INCLUDING ALL COMPONENTS THEREOF, SHALL BE NEW AND SHALL APPEAR ON THE LIST OF U.I. APPROVED ITEMS AND SHALL MEET OR EXCEED THE REQUIREMENTS OF THE NEC, NEMA AND IEC.
17. CONTRACTOR SHALL SUBMIT SHOP DRAWINGS OR MANUFACTURER'S CATALOG INFORMATION OF ANY/ALL EQUIPMENT AND ALL OTHER ELECTRICAL ITEMS FOR APPROVAL BY THE MOBILITIE CM PRIOR TO INSTALLATION.
18. ANY CUTTING OR PATCHING DEEMED NECESSARY FOR ELECTRICAL WORK IS THE ELECTRICAL CONTRACTOR'S RESPONSIBILITY AND SHALL BE INCLUDED IN THE COST FOR WORK AND PERFORMED TO THE SATISFACTION OF THE MOBILITIE CM UPON FINAL ACCEPTANCE.
19. THE ELECTRICAL CONTRACTOR SHALL LABEL ALL PANELS WITH ONLY TYPEWRITTEN DIRECTORIES. ALL ELECTRICAL WIRING SHALL BE THE RESPONSIBILITY OF THE ELECTRICAL CONTRACTOR.
20. DISCONNECT SWITCHES SHALL BE UL-RATED, H.P. RATED HEAVY-DUTY, QUICK-MAKE AND QUICK-BREAK ENCLOSURES, AS REQUIRED BY EXPOSURE TYPE.
21. ALL CONNECTIONS SHALL BE MADE WITH A PROTECTIVE COATING OF AN ANTI-OXIDE COMPOUND KNOWN AS "NO-OXIDE A" BY DEARBORNE CHEMICAL CO. COAT ALL WIRE SURFACES BEFORE CONNECTING EXPOSED COPPER SURFACES, INCLUDING GROUND BARS, SHALL BE TREATED - NO SUBSTITUTIONS.
22. RACEWAYS: CONDUIT SHALL BE SCHEDULE 80 PVC MEETING OR EXCEEDING NEMA TC2 - 1990. CONTRACTOR SHALL PLUG AND CAP EACH END OF SPARE AND EMPTY CONDUITS AND PROVIDE TWO SEPARATE PULL STRINGS - 200 LBS TEST POLYETHYLENE CORD. ALL CONDUIT BENDS SHALL BE A MINIMUM OF 2 FT. RADIUS. RIGID CONDUITS WHEN SPECIFIED, SHALL MEET UL-B FOR GALVANIZED STEEL. ALL FITTINGS SHALL BE SUITABLE FOR USE WITH THREADED RIGID CONDUIT. COAT ALL THREADS WITH "BRITE ZINC" OR "COLD GALV".
23. SUPPORT OF ALL ELECTRICAL WORK SHALL BE AS REQUIRED BY NEC.
24. CONDUCTORS: CONTRACTOR SHALL USE 98% CONDUCTIVITY COPPER WITH TYPE THIN INSULATION, UNLESS OTHERWISE NOTED, 600 VOLT, COLOR CODED. USE SOLID CONDUCTORS FOR WIRE UP TO AND INCLUDING NO. 8 AWG, USE STRANDED CONDUCTORS FOR WIRE ABOVE NO. 8 AWG.
25. CONNECTORS FOR POWER CONDUCTORS: CONTRACTOR SHALL USE PRESSURE TYPE INSULATED TWIST-ON CONNECTORS FOR NO. 10 AWG AND SMALLER, USE SOLDERLESS MECHANICAL TERMINAL LUGS FOR NO. 8 AWG AND LARGER.
26. SERVICE: AS SPECIFIED ON THE DRAWINGS, OWNER OR OWNER'S AGENT WILL APPLY FOR POWER. ALL PROVISIONS FOR TEMPORARY POWER WILL BE OBTAINED BY THE CONTRACTOR.
27. TELEPHONE OR FIBER SERVICE: CONTRACTOR SHALL PROVIDE EMPTY CONDUITS WITH PULL STRINGS AS INDICATED ON DRAWINGS.
28. ELECTRICAL AND TELCO/FIBER RACEWAYS TO BE BURIED A MINIMUM DEPTH OF 30", UNLESS OTHERWISE NOTED.
29. CONTRACTOR SHALL PLACE 6" WIDE DETECTABLE WARNING TAPE AT A DEPTH OF 6" BELOW GROUND AND DIRECTLY ABOVE ELECTRICAL AND TELCO SERVICE CONDUITS. CAUTIONS TAPE TO READ "CAUTION BURIED ELECTRIC" OR "BURIED TELECOMM".
30. ALL BOLTS SHALL BE 3-16 STAINLESS STEEL.
31. THE ELECTRICAL CONTRACTOR SHALL LABEL ALL PANELS WITH ONLY TYPEWRITTEN

DIRECTORIES. ALL ELECTRICAL WIRING SHALL BE THE RESPONSIBILITY OF THE ELECTRICAL CONTRACTOR.

GROUNDING NOTES:

1. ALL HARDWARE SHALL BE 3-16 STAINLESS STEEL, INCLUDING LOCK WASHERS. COAT ALL SURFACES WITH AN ANTI-OXIDANT COMPOUND, AS SPECIFIED, BEFORE MATING. ALL HARDWARE SHALL BE STAINLESS STEEL 3/8 INCH DIAMETER OR LARGER.
2. FOR GROUND BOND TO STEEL ONLY: INSERT A CADMIUM FLAT WASHER BETWEEN LUG AND STEEL. COAT ALL SURFACES WITH AN ANTI-OXIDANT COMPOUND BEFORE MATING.
3. ALL STEEL CONDUIT SHALL BE BONDED AT BOTH ENDS WITH GROUNDING BUSHING.
4. ALL ELECTRICAL AND GROUNDING AT THE POLE SITE SHALL COMPLY WITH THE NATIONAL ELECTRICAL CODE (NEC), NATIONAL FIRE PROTECTION ASSOCIATION (NFPA) 780 (LATEST EDITION), AND MANUFACTURER.
5. ALL DETAILS ARE SHOWN IN GENERAL TERMS. ACTUAL GROUNDING INSTALLATION AND CONSTRUCTION MAY VARY DUE TO SITE SPECIFIC CONDITIONS.
6. GROUND ALL ANTENNA BASES, FRAMES, CABLE RUNS, AND OTHER METALLIC COMPONENTS USING #6 GROUND WIRES. FOLLOW ANTENNA AND BTS MANUFACTURER'S PRACTICES FOR GROUNDING REQUIREMENTS.
7. ALL GROUND CONNECTIONS SHALL BE #6 AWG, UNLESS OTHERWISE NOTED. ALL WIRES SHALL BE COPPER WITH THIN, UNLESS OTHERWISE NOTED. ALL GROUND WIRE SHALL BE SOLID TIN COATED OR STRANDED GREEN INSULATED WIRE.
8. CONTRACTOR TO VERIFY AND TEST GROUND TO SOURCE, 10 OHMS MAXIMUM. PROVIDE SUPPLEMENT GROUNDING RODS AS REQUIRED TO ACHIEVE SPECIFIED OHMS READING. GROUNDING AND OTHER OPTIONAL TESTING WILL BE WITNESSED BY THE MOBILITIE CM.
9. NOTIFY ARCHITECT/ENGINEER IF THERE ARE ANY DIFFICULTIES INSTALLING GROUNDING SYSTEM DUE TO SITE SOIL CONDITIONS.
10. ALL HORIZONTALLY RUN GROUNDING CONDUCTORS SHALL BE INSTALLED A MINIMUM OF 30" BELOW GRADE/ 6" BELOW FROST-LINE IN TRENCH, UNLESS OTHERWISE NOTED. BACK FILL SHALL BE COMPACTED AS REQUIRED BY ARCHITECT/ENGINEER.
11. ALL GROUND CONDUCTORS SHALL BE RUN AS STRAIGHT AND SHORT AS POSSIBLE, WITH A MINIMUM 12" BENDING RADIUS NOT LESS THAN 90 DEGREES.
12. ACCEPTABLE CONNECTIONS FOR GROUNDING SYSTEM SHALL BE:
  - A. BURNDY, HY-GRADE U.L. LISTED CONNECTORS FOR OUTDOOR USE OR AS APPROVED BY APPLICANT PROJECT MANAGER.
  - B. COLDWELD, EXOTHERMIC WELDS (WELDED CONNECTIONS).
  - C. ONE (1) HOLE TINNED COPPER COMPRESSION (LONG BARREL) FITTINGS.
13. ALL CRIMPED CONNECTIONS SHALL HAVE EMBOSSED MANUFACTURER'S MARKER VISIBLE AT THE CRIMP (RESULTING FROM USE OF PROPER CRIMPING DEVICES) AND WEATHER-PROOFED WITH HEAT SHRINK.
14. ALL CONNECTION HARDWARE SHALL BE TYPE 3-16 STAINLESS STEEL (NOT ATTRACTED TO MAGNETS).
15. ELECTRICAL SERVICE EQUIPMENT GROUNDING SHALL COMPLY WITH NEC, ARTICLE 250-82 AND SHALL BOND ALL (E) AND NEW GROUNDING ELECTRODES. NEW GROUNDING ELECTRODE SHALL INCLUDE BUT NOT LIMITED TO GROUND RODS.

TESTING AND EQUIPMENT TURN-UP REQUIREMENTS:

1. RF CABLE, DATA CABLE, RADIO EQUIPMENT AND BACK HAUL EQUIPMENT TESTING WILL COMPLY WITH CURRENT INDUSTRY STANDARDS AND OR THOSE STANDARDS OF THE EQUIPMENT MANUFACTURER OR PROVIDED TO THE CONTRACTOR PRIOR TO TESTING.
2. CONTRACTOR WILL USE THE APPROPRIATE CALIBRATED TESTING EQUIPMENT IN THE TESTING OF RF CABLE, DATA CABLE, RADIO EQUIPMENT AND BACK HAUL EQUIPMENT THAT MEET INDUSTRY STANDARDS OF THE MANUFACTURER OR THOSE STANDARDS PROVIDED TO THE CONTRACTOR PRIOR TO TESTING.
3. CONTRACTOR TO VERIFY AND RECORD ALL TEST RESULTS AND PROVIDE THESE RESULTS WITHIN THE FINAL CLOSE OUT PACKAGE.
4. ALL PERSONNEL INVOLVED IN THE TESTING OF RF CABLE, DATA CABLE, RADIO EQUIPMENT AND BACK HAUL EQUIPMENT WILL BE REQUIRED TO HAVE BEEN TRAINED AND OR CERTIFIED IN THE PROPER TESTING OF RF CABLE, DATA CABLE, RADIO EQUIPMENT AND BACK HAUL EQUIPMENT.
5. ALL TEST RESULTS SHALL BE TIME STAMPED, RECORDED AND PRESENTED PRIOR TO ENERGIZING AND TURN UP OF ANY EQUIPMENT.
6. GPS EQUIPMENT IS NOT TO BE TESTED OR ATTACHED TO ANY CABLING DURING TESTING, DOING SO WILL DAMAGE THE GPS UNIT.
7. PRIOR TO TESTING IF THE CONTRACTOR HAS ANY QUESTIONS ABOUT THE TESTING PROCEDURES THEY ARE TO CALL AND OBTAIN ASSISTANCE FROM A QUALIFIED DESIGNATED TESTING REPRESENTATIVE.
8. EQUIPMENT IS NOT TO BE ENERGIZED UNTIL ALL TESTING HAS BEEN COMPLETED, APPROVED AND THE APPROPRIATE AUTHORITY HAS BEEN NOTIFIED AND GIVEN APPROVAL TO ENERGIZE THE EQUIPMENT.

SITE WORK NOTES:

1. DO NOT EXCAVATE OR DISTURB BEYOND THE PROPERTY LINES OR LEASE LINES, UNLESS OTHERWISE NOTED.
2. SIZE, LOCATION AND TYPE OF ANY UNDERGROUND UTILITIES OR IMPROVEMENTS SHALL BE ACCURATELY NOTED AND PLACED ON AS-BUILT DRAWINGS BY GENERAL CONTRACTOR AND ISSUED TO ARCHITECT/ENGINEER AT COMPLETION OF PROJECT.
3. ALL (E) UTILITIES, FACILITIES, CONDITIONS AND THEIR DIMENSIONS SHOWN ON PLANS HAVE BEEN PLOTTED FROM AVAILABLE RECORDS. THE ENGINEER AND OWNER ASSUME NO RESPONSIBILITY WHATSOEVER AS TO THE SUFFICIENCY OR ACCURACY OF THE INFORMATION SHOWN ON THE PLANS OR THE MANNER OF THEIR REMOVAL OR ADJUSTMENT. CONTRACTOR SHALL BE RESPONSIBLE FOR DETERMINING EXACT LOCATION OF ALL (E) UTILITIES AND FACILITIES PRIOR TO START OF CONSTRUCTION. CONTRACTOR SHALL ALSO OBTAIN FROM EACH UTILITY COMPANY DETAILED INFORMATION RELATIVE TO WORKING SCHEDULES AND METHODS OF REMOVING OR ADJUSTING (E) UTILITIES.
4. CONTRACTOR SHALL VERIFY ALL (E) UTILITIES BOTH HORIZONTALLY AND VERTICALLY PRIOR TO START OF CONSTRUCTION. ANY DISCREPANCIES OR DOUBTS AS TO THE INTERPRETATION OF PLANS SHALL BE IMMEDIATELY REPORTED TO THE ARCHITECT/ENGINEER OR MOBILITIE CM FOR RESOLUTION AND INSTRUCTION, AND NO FURTHER WORK SHALL BE PERFORMED UNTIL THE DISCREPANCY IS CHECKED AND CORRECTED BY THE ARCHITECT/ENGINEER. FAILURE TO SECURE SUCH INSTRUCTION MEANS CONTRACTOR WILL HAVE WORKED AT THEIR OWN RISK AND EXPENSE. CONTRACTOR SHALL CALL LOCAL UTILITY LOCATE HOT LINE, SUCH AS 811, FOR UTILITY LOCATIONS A MINIMUM OF 48 HOURS PRIOR TO START OF CONSTRUCTION.
5. ALL NEW AND (E) UTILITY STRUCTURES ON SITE AND IN AREAS TO BE DISTURBED BY CONSTRUCTION SHALL BE ADJUSTED TO FINISH ELEVATIONS PRIOR TO FINAL INSPECTION OF WORK. ANY COST RELATED TO ADJUSTING (E) STRUCTURES SHALL BE BORNE SOLELY BY THE CONTRACTOR.
6. GRADING OF THE SITE WORK AREA IS TO BE SMOOTH AND CONTINUOUS IN SLOPE AND IS TO FEATHER INTO (E) GRADES AT THE GRADING LIMITS.
7. ALL TEMPORARY EXCAVATIONS FOR THE INSTALLATION OF FOUNDATIONS, UTILITIES, ETC., SHALL BE PROPERLY LAID BACK OR BRACED IN ACCORDANCE WITH CORRECT OCCUPATIONAL SAFETY AND HEALTH ADMINISTRATION (OSHA) REQUIREMENTS.



PROJECT NO:	9CAB013267
DRAWN BY:	DK
CHECKED BY:	JM

0	07/21/17	90% CONSTRUCTION
1	08/29/17	REVISED PER PG&E STANDARDS

IT IS A VIOLATION OF THE LAW FOR ANY PERSON, UNLESS THEY ARE ACTING UNDER THE DIRECTION OF A LICENSED PROFESSIONAL ENGINEER, TO ALTER THIS DOCUMENT.

9CAB013267  
OAKLAND, CA 94602  
(E) 29'-0" STEEL LIGHT POLE

SHEET TITLE  
GENERAL NOTES

SHEET NUMBER  
GN-2



SITE WORK NOTES CONT'D

8. STRUCTURAL FILLS SUPPORTING PAVEMENTS SHALL BE COMPACTED TO 95% OF MAXIMUM STANDARD PROCTOR DRY DENSITY, UNLESS OTHERWISE NOTED.
9. NEW GRADES FILL IN BUILDING AND DRIVEWAY IMPROVEMENT AREA TO BE ACHIEVED BY FILLING WITH APPROVED CLEAN FILL AND COMPACTED TO 95% OF STANDARD PROCTOR DENSITY.
10. ALL FILL SHALL BE PLACED IN UNIFORM LIFTS. THE LIFTS THICKNESS SHOULD NOT EXCEED THAT WHICH CAN BE PROPERLY COMPACTED THROUGHOUT ITS ENTIRE DEPTH WITH THE EQUIPMENT AVAILABLE.
11. ANY FILLS PLACED ON (E) SLOPES THAT ARE STEEPER THAN 10 HORIZONTAL TO 1 VERTICAL SHALL BE PROPERLY BENCHED INTO THE (E) SLOPE AS DIRECTED BY A GEOTECHNICAL ENGINEER.
12. CONTRACTOR SHALL CLEAN ENTIRE SITE AFTER CONSTRUCTION SUCH THAT NO DEBRIS, PAPER, TRASH, WEEDS, BRUSH, EXCESS FILL, OR ANY OTHER DEPOSITS WILL REMAIN. ALL MATERIALS COLLECTED DURING CLEANING OPERATIONS SHALL BE DISPOSED OF OFF-SITE BY THE GENERAL CONTRACTOR.
13. ALL TREES AND SHRUBS WHICH ARE NOT IN DIRECT CONFLICT WITH THE IMPROVEMENTS SHALL BE PROTECTED BY THE GENERAL CONTRACTOR.
14. ALL SITE WORK SHALL BE CAREFULLY COORDINATED BY GENERAL CONTRACTOR WITH LOCAL UTILITY COMPANY, TELEPHONE COMPANY, AND ANY OTHER UTILITY COMPANIES HAVING JURISDICTION OVER THIS LOCATION.

ENVIRONMENTAL NOTES:

1. ALL WORK PERFORMED SHALL BE DONE IN ACCORDANCE WITH ISSUED PERMITS. THE CONTRACTOR SHALL BE RESPONSIBLE FOR PAYMENT OF FINES AND PROPER CLEAN UP FOR AREAS IN VIOLATION.
2. CONTRACTOR SHALL BE RESPONSIBLE FOR CONSTRUCTION AND MAINTENANCE OF EROSION AND SEDIMENTATION CONTROLS DURING CONSTRUCTION FOR PROTECTION OF ADJACENT PROPERTIES, ROADWAYS AND WATERWAYS. ALL EROSION AND SEDIMENTATION CONTROLS SHALL BE MAINTAINED IN PLACE THROUGH FINAL JURISDICTIONAL INSPECTION & RELEASE OF SITE.
3. CONTRACTOR SHALL INSTALL/CONSTRUCT ALL NECESSARY SEDIMENT/SILT CONTROL FENCING AND PROTECTIVE MEASURES AS REQUIRED BY THE LOCAL JURISDICTION WITHIN THE LIMITS OF SITE DISTURBANCE PRIOR TO CONSTRUCTION.
4. NO SEDIMENT SHALL BE ALLOWED TO EXIT THE PROPERTY. THE CONTRACTOR IS RESPONSIBLE FOR TAKING ADEQUATE MEASURES FOR CONTROLLING EROSION. ADDITIONAL SEDIMENT CONTROL FENCING MAY BE REQUIRED IN ANY AREAS SUBJECT TO EROSION.
5. THE CONTRACTOR IS RESPONSIBLE FOR MAINTAINING POSITIVE DRAINAGE ON THE SITE AT ALL TIMES WITH SILT AND EROSION CONTROL MEASURES MAINTAINED ON THE DOWNSTREAM SIDE OF SITE DRAINAGE. ANY DAMAGE TO ADJACENT PROPERTY AS A RESULT OF EROSION WILL BE CORRECTED AT THE CONTRACTORS EXPENSE.
6. CONTRACTOR SHALL BE RESPONSIBLE FOR DAILY INSPECTIONS AND ANY REPAIRS OF ALL SEDIMENT CONTROL MEASURES INCLUDING SEDIMENT REMOVAL AS NECESSARY.
7. CLEARING OF VEGETATION AND TREE REMOVAL SHALL BE ONLY AS PERMITTED AND BE HELD TO A MINIMUM. ONLY TREES NECESSARY FOR CONSTRUCTION OF THE FACILITIES SHALL BE REMOVED.
8. SEEDING AND MULCHING AND/OR SODDING OF THE SITE WILL BE ACCOMPLISHED AS SOON AS POSSIBLE AFTER COMPLETION OF THE PROJECT FACILITIES AFFECTING LAND DISTURBANCE.
9. CONTRACTOR SHALL PROVIDE ALL EROSION AND SEDIMENTATION CONTROL MEASURES AS REQUIRED BY LOCAL, COUNTY AND STATE CODES AND ORDINANCES TO PROTECT EMBANKMENTS FROM SOIL LOSS AND TO PREVENT ACCUMULATION OF SOIL AND SILT IN STREAMS AND DRAINAGE PATHS LEAVING THE CONSTRUCTION AREA. THIS MAY INCLUDE, BUT IS NOT LIMITED TO SUCH MEASURES AS SILT FENCES, STRAW BALE SEDIMENT BARRIERS, AND CHECK DAMS.
10. RIP RAP OF SIZES INDICATED SHALL CONSIST OF CLEAN, HARD, SOUND, DURABLE, UNIFORM IN QUALITY STONE FREE OF ANY DETRIMENTAL QUANTITY OF SOFT, FRIABLE, THIN, ELONGATED OR LAMINATED PIECES, DISINTEGRATED MATERIAL, ORGANIC MATTER, OIL, ALKALI, OR OTHER DELETERIOUS SUBSTANCES.

11. GC TO PLACE FILTER MATERIAL AT ALL CATCH BASINS ADJACENT TO CONSTRUCTION SITE TO PREVENT SOLID WASTE CONTAMINATION FROM ENTERING SEWER SYSTEM.

FOUNDATION, EXCAVATION, AND BACKFILL NOTES:

1. ALL FINAL GRADED SLOPES SHALL BE A MAXIMUM OF 3 HORIZONTAL TO 1 VERTICAL, UNLESS OTHERWISE NOTED.
2. BACKFILL OF POLE SHALL BE PERFORMED IN ONE OF THREE OPTIONS:
  - A. PREFERRED: RAINBOW INDUSTRIES POLE SETTING FOAM SHALL BE INSTALLED PER MANUFACTURER SPECS. FOAM SHALL ALWAYS BE USED FOR POOR SOILS.
  - B. SECONDARY: CONCRETE (REQUIRES MOBILITIE CM WRITTEN APPROVAL) ALLOWABLE SOIL PRESSURE = 2000 PSF (ASSUMED) NON-NATIVE SOILS SHALL BE REMOVE FROM BORE AREA AND SHALL NOT BE REUSED FOR BACKFILL.
3. ALL EXCAVATIONS PREPARED FOR PLACEMENT OF CONCRETE SHALL BE OF UNDISTURBED SOILS, SUBSTANTIALLY HORIZONTAL AND FREE FROM ANY LOOSE, UNSUITABLE MATERIAL OR FROZEN SOILS, AND WITHOUT THE PRESENCE OF POUNDING WATER. DEWATERING FOR EXCESS GROUND WATER SHALL BE PROVIDED WHEN REQUIRED. COMPACTION OF SOILS UNDER CONCRETE PAD FOUNDATIONS SHALL NOT BE LESS THAN 95% OF THE MODIFIED PROCTOR MAXIMUM DRY DENSITY FOR THE SOIL IN ACCORDANCE WITH ASTM D1557.
4. CONCRETE FOUNDATIONS SHALL NOT BE PLACED ON ORGANIC OR UNSUITABLE MATERIAL & ADEQUATE BEARING CAPACITY IS NOT ACHIEVED AT THE DESIGNED EXCAVATION DEPTH, THE UNSATISFACTORY SOIL SHALL BE EXCAVATED TO ITS FULL DEPTH AND EITHER BE REPLACED WITH MECHANICALLY COMPACTED GRANULAR MATERIAL OR THE EXCAVATION SHALL BE FILLED WITH CONCRETE OF THE SAME TYPE SPECIFIED FOR THE FOUNDATION. CRUSHED STONE MAY BE USED TO STABILIZE THE BOTTOM OF THE EXCAVATION. ANY STONE SUB BASE MATERIAL, IF USED, SHALL NOT SUBSTITUTE FOR REQUIRED THICKNESS OF CONCRETE.
5. ALL EXCAVATIONS SHALL BE CLEAN OF UNSUITABLE MATERIAL SUCH AS VEGETATION, TRASH, DEBRIS, AND SO FORTH PRIOR TO BACK FILLING. BACK FILL SHALL CONSIST OF APPROVED MATERIALS SUCH AS EARTH, LOAM, SANDY CLAY, SAND AND GRAVEL, OR SOFT SHALE, FREE FROM CLODS OR LARGE STONES OVER 2 1/2" MAX DIMENSIONS. ALL BACK FILL SHALL BE PLACED IN COMPACTED LAYERS.
6. ALL FILL MATERIALS AND FOUNDATION BACK FILL SHALL BE PLACED IN MAXIMUM 6" THICK LIFTS BEFORE COMPACTION. EACH LIFT SHALL BE METTED IF REQUIRED AND COMPACTED TO NOT LESS THAN 95% OF THE MODIFIED PROCTOR MAXIMUM DRY DENSITY FOR SOIL IN ACCORDANCE WITH ASTM D1557.
7. NEWLY PLACED CONCRETE FOUNDATIONS SHALL CURE A MINIMUM OF 72 HRS PRIOR TO BACK FILLING.
8. FINISHED GRADING SHALL BE SLOPED TO PROVIDE POSITIVE DRAINAGE AND PREVENT STANDING WATER. THE FINAL (FINISH) ELEVATION OF SLAB FOUNDATIONS SHALL SLOPE AWAY IN ALL DIRECTIONS FROM THE CENTER. FINISH GRADE OF CONCRETE PADS SHALL BE A MAXIMUM OF 4 INCHES ABOVE FINAL FINISH GRADE ELEVATIONS. PROVIDE SURFACE FILL GRAVEL TO ESTABLISH SPECIFIED ELEVATIONS WHERE REQUIRED.
9. NEWLY GRADED GRAVEL SURFACE AREAS TO RECEIVE GRAVEL SHALL BE COVERED WITH GEOTEXTILE FABRIC TYPE: TYPAR-3401 AS MANUFACTURED BY TYPAR GEOSYNTHETICS OR AN APPROVED EQUIVALENT. SHOWN ON PLANS. THE GEOTEXTILE FABRIC SHALL BE BLACK IN COLOR TO CONTROL THE RECURRENCE OF VEGETATIVE GROWTH AND EXTEND TO WITHIN 1 FOOT OUTSIDE THE SITE FENCING OR ELECTRICAL GROUNDING SYSTEM PERIMETER WHICH EVER IS GREATER. ALL FABRIC SHALL BE COVERED WITH A MINIMUM OF 4" DEEP COMPACTED STONE OR GRAVEL AS SPECIFIED. I.E. FDOT TYPE NO. 57 FOR FENCED COMPOUND; FDOT TYPE NO. 67 FOR ACCESS DRIVE AREA, UNLESS OTHERWISE NOTED.
10. IN ALL AREAS TO RECEIVE FILL: REMOVE ALL VEGETATION, TOPSOIL, DEBRIS, WET AND UNSATISFACTORY SOIL, MATERIALS, OBSTRUCTIONS, AND DELETERIOUS MATERIALS FROM GROUND SURFACE. PLOW STRIP OR BREAK UP SLOPED SURFACES STEEPER THAN 1 VERTICAL TO 4 HORIZONTAL SUCH THAT FILL MATERIAL WILL BIND WITH (E)/PREPARED SOIL SURFACE.
11. WHEN SUB GRADE OR PREPARED GROUND SURFACE HAS A DENSITY LESS THAN THAT REQUIRED FOR THE FILL MATERIAL, SCARIFY THE GROUND SURFACE TO DEPTH REQUIRED, PULVERIZE, MOISTURE-CONDITION AND/OR AERATE THE SOILS AND RECOMPACT TO THE REQUIRED DENSITY PRIOR TO PLACEMENT OF FILLS.
12. IN AREAS WHICH (E) GRAVEL SURFACING IS REMOVED OR DISTURBED DURING CONSTRUCTION OPERATIONS, REPLACE GRAVEL SURFACING TO MATCH ADJACENT

GRAVEL SURFACING AND RESTORED TO THE SAME THICKNESS AND COMPACTION AS SPECIFIED. ALL RESTORED GRAVEL SURFACING SHALL BE FREE FROM CORRUGATIONS AND WAVES.

13. (E) GRAVEL SURFACING MAY NOT BE REVISED.
14. GRAVEL SUB SURFACE SHALL BE PREPARED TO REQUIRED COMPACTION AND SUB GRADE ELEVATIONS BEFORE GRAVEL SURFACING IS PLACED AND/OR RESTORED. ANY LOOSE OR DISTURBED MATERIALS SHALL BE THOROUGHLY COMPACTED AND ANY DEPRESSIONS IN THE SUB GRADE SHALL BE FILLED AND COMPACTED WITH APPROVED SELECTED MATERIAL. GRAVEL SURFACING MATERIAL SHALL NOT BE USED FOR FILLING DEPRESSIONS IN THE SUB GRADE.
15. PROTECT (E) GRAVEL SURFACING AND SUB GRADE IN AREAS WHERE EQUIPMENT LOADS WILL OPERATE. USE PLANKING MATTS' OR OTHER SUITABLE PROTECTION DESIGNED TO SPREAD EQUIPMENT LOADS AS MAY BE NECESSARY. REPAIR ANY DAMAGE TO (E) GRAVEL SURFACING OR SUB GRADE WHERE SUCH DAMAGE IS DUE TO THE CONTRACTORS OPERATIONS.
16. DAMAGE TO (E) STRUCTURES AND/OR UTILITIES RESULTING FROM CONTRACTORS NEGLIGENCE SHALL BE REPAIRED AND/ OR REPLACED TO THE OWNERS SATISFACTION AT NO ADDITIONAL COST TO THE CONTRACT.
17. ALL SUITABLE BORROW MATERIAL FOR BACK FILL OF THE SITE SHALL BE INCLUDED IN THE BID. EXCESS TOPSOIL AND UNSUITABLE MATERIAL SHALL BE DISPOSED OF OFF SITE AT LOCATIONS APPROVED BY GOVERNING AGENCIES AT NO ADDITIONAL COST TO THE CONTRACT.

MISCELLANEOUS MATERIALS

FROM TIME TO TIME IT MAY BE NECESSARY TO MAKE MINOR ADJUSTMENTS TO ACCOMMODATE LEVEL OR SPACE ANTENNA MOUNTS AND EQUIPMENT. EXAMPLE ADDING A WASHER OR SHIM TO LEVEL OUT A BRACKET OR MOUNT TO MEET SPECIFICATIONS. HAVING TO OFFSET OR SPACE A BRACKET OR MOUNT DUE TO FLANGES AND OR OTHER SMALL PROTRUSIONS ON A POLE TOP ASSEMBLY. ANY MATERIALS, NUTS, BOLTS, SHIMS OR SPACERS USED TO ACCOMMODATE ADJUSTMENTS TO ANTENNA MOUNTS AND EQUIPMENT MUST BE PERMANENTLY AFFIXED, BOLTED TO THE MOUNT, BRACKET OR POLE. AS NEVER TO BECOME A FALL HAZARD. ALL MATERIALS NUTS, BOLTS, SHIMS OR SPACERS USED IN MINOR ADJUSTMENTS, MUST BE EITHER STAINLESS STEEL OR GALVANIZED; HALF WASHERS ARE PROHIBITED. ANY MINOR ADJUSTMENTS TO ACCOMMODATE ANTENNA MOUNTS AND EQUIPMENT SHOULD BE DONE IN A PROFESSIONAL MANNER WITH SAFETY AND AESTHETICS IN MIND. SHOULD YOU HAVE ANY QUESTIONS CONTACT YOUR ASSIGNED CONSTRUCTION PROJECT MANAGER OR ENGINEER FOR GUIDANCE.



PROJECT NO: SCAB013267  
 DRAWN BY: DK  
 CHECKED BY: JM

D	07/19/17	REV CONSTRUCTION
1	08/28/17	REVISED PER PG&E STANDARDS

IT IS A VIOLATION OF THE LAW FOR ANY PERSON, UNLESS THEY ARE ACTING UNDER THE DIRECTION OF A LICENSED PROFESSIONAL ENGINEER, TO ALTER THIS DOCUMENT

SCAB013267  
 OAKLAND, CA 94602  
 (E) 29'-0" STEEL LIGHT POLE

SHEET TITLE  
 GENERAL NOTES

SHEET NUMBER  
 GN-3



**DURATION NOTES**

1. "ROAD WORK AHEAD" and the "BE PREPARED TO STOP" signs may be omitted if all of the following conditions are met:
  - a. Work operations are 60 minutes or less
  - b. Speed limit is 45 MPH or less
  - c. No sight obstructions to vehicles approaching the work area for a distance equal to the buffer space
  - d. Vehicles in the work area have high-intensity, rotating, flashing, oscillating, or strobe lights operating
  - e. Volume and complexity of the roadway has been considered

**TRAFFIC CONTROL PLANS**

**GENERAL NOTES**

1. ALL WORK AND MATERIALS SHALL COMPLY WITH THE WORK AREA TRAFFIC CONTROL HANDBOOK (WATCH) 2016 EDITION.
2. ALL STRIPING AND MARKINGS SHALL CONFORM TO THE STATE OF CALIFORNIA, STANDARD PLANS AND SPECIFICATIONS, INCLUDING STANDARD PLAN A-20, DETAILS.
3. THE CONTRACTOR SHALL PROVIDE FOR ACCESS TO ALL ADJACENT PROPERTIES.
4. FLASHING YELLOW BEACONS, TYPE "B", SHALL BE USED ON ALL W20-1 SIGNS AND ON ALL TYPE III BARRICADES GUARDING THE WORK AREA OVERSIGHT.
5. ALL SIGNS SHALL BE REFLECTORIZED AND STANDARD SIZE.
6. ALL TUBULAR DELINEATORS AND CONES SHALL BE 26" MINIMUM HEIGHT, REFLECTORIZED AND MAINTAINED ERECT IN THE INDICATED POSITION AT ALL TIMES, AND SHALL BE REPAIRED, REPLACED, OR CLEANED AS NECESSARY TO PRESERVE THEIR APPEARANCE AND CONTINUITY, AND SHALL INCLUDE A 12" HIGH-INTENSITY REFLECTORIZED SLEEVE, IF USED DURING NIGHT-TIME HOURS.
7. THE CONTRACTOR SHALL MAINTAIN, ON A CONTINUOUS BASIS, ALL SIGNS, DELINEATORS, BARRICADES, ETC., TO ENSURE PROPER FLOW AND SAFETY OF TRAFFIC DURING CONSTRUCTION.
8. THE CONTRACTOR SHALL HAVE ALL SIGNS, DELINEATORS, BARRICADES, ETC., PROPERLY INSTALLED PRIOR TO COMMENCING CONSTRUCTION.
9. CONSTRUCTION OPERATIONS SHALL BE CONDUCTED IN SUCH A MANNER AS TO CAUSE AS LITTLE INCONVENIENCE AS POSSIBLE TO ADJUTING PROPERTY OWNERS.
10. ADDITIONAL TRAFFIC CONTROLS, TRAFFIC SIGNS, OR BARRICADEING MAY BE REQUIRED IN THE FIELD. THE CONTRACTOR SHALL BE RESPONSIBLE FOR THE PLACEMENT OF ANY ADDITIONAL DEVICES NECESSARY TO ASSURE SAFETY TO THE PUBLIC AT ALL TIMES DURING CONSTRUCTION.
11. EXACT LOCATION AND TYPE OF CONSTRUCTION SIGNS SHALL BE DIRECTED BY THE ENGINEER BASED UPON CONSTRUCTION CONDITIONS.
12. MOVE DELINEATORS AND/OR CONES TO SIDEWALK DURING NON-WORKING HOURS. REMOVE BARRICADES ETC. FROM TRAVEL LANE.
13. REMOVE OR TURN OFF SIGNS DURING NON-WORK HOURS.
14. ALL CONFLICTING LINES, EXISTING CURB PAINT, AND MARKINGS SHALL BE REMOVED BY WET SANDBLASTING OR OTHER APPROVED METHOD PRIOR TO INSTALLATION OF NEW/TEMPORARY STRIPING. ALL CONFLICTING RAISED PAVEMENT MARKERS SHALL BE REMOVED. PAVEMENT THAT IS DAMAGED DUE TO REMOVAL OF MARKERS SHALL BE REPAIRED TO THE SATISFACTION OF THE CITY ENGINEER AND/OR STATE INSPECTOR.

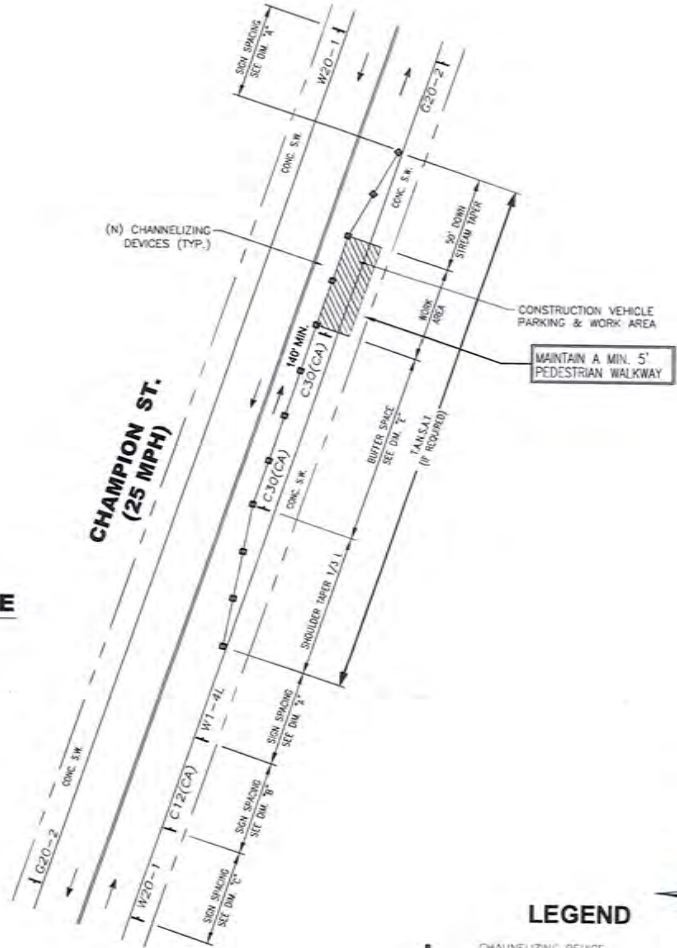

**PARTIAL RIGHT LANE CLOSURE  
2016 WATCH PAGE 35**

**SIGNS**



\* ADDITIONAL SIGNS MAY BE REQUIRED TO ACCOMMODATE ACTUAL FIELD CONDITIONS.

**LEGEND**

- CHAINLIZING DEVICE
- SIGN
- ▨ WORK SPACE
- ⌋ FLAGGER
- ➔ DIRECTION OF TRAFFIC



**NOTES**

1. INGRESS AND EGRESS MUST BE PROVIDED TO ALL DRIVEWAYS AT ANY TIME. USE BULL NOSE TO TERMINATE TAPER AT DRIVEWAYS.
2. STEEL PLATES TO BE USED TO MAINTAIN TRAFFIC FLOW ON ALL DRIVEWAYS.

**TEMPORARY TRAFFIC CONTROL PLAN DIMENSION GUIDELINES**

SPEED MPH (S)	MINIMUM BUFFER SPACE (ft)		MINIMUM TAPER LENGTH (ft)		MINIMUM SHOULDER WIDTH (ft)		MINIMUM BUFFER SPACE AND PLACEMENT FROM STOPPING POINT (ft)		MINIMUM DELINEATOR TAPER SPACING (ft)		MINIMUM DELINEATOR CONTACT SPACING (ft)	
	(S)	(S)	(S)	(S)	(S)	(S)	(S)	(S)	(S)	(S)	(S)	(S)
25	100	125	65	45	(1)50	(1)60	(1)50	25	60	60	12	12
30	150	180	80	60	(2)50	(2)60	(2)50	30	80	80	15	15
35	200	245	100	80	(3)50	(3)60	(3)50	40	100	100	17	17
40	250	320	130	110	(4)50	(4)60	(4)50	50	130	130	20	20
45	300	360	160	140	(5)50	(5)60	(5)50	60	160	160	22	22
50	350	420	200	180	(6)50	(6)60	(6)50	70	200	200	25	25
55	400	480	240	220	(7)50	(7)60	(7)50	80	240	240	28	28
60	450	540	280	260	(8)50	(8)60	(8)50	90	280	280	30	30
65	500	600	320	300	(9)50	(9)60	(9)50	100	320	320	32	32

(1) Work on Freeways and Expressways shall meet the California Standard Plans and Standard Specifications requirements.  
 (2) Posted Speed or observed operating speed (whichever is greater).  
 (3) Channelizer spacing shall be reduced by half of areas where work is taking place on curves or areas of restricted visibility.  
 (4-A) Buffer space may be inserted in low-speed urban areas and should be inserted in high-speed urban and rural areas.  
 (4-B) The Stopping Sign Distance should create Road Users to see the Primary Flagging Station and safety ahead.  
 (5) Sign spacing in rural areas should be 500 ft.  
 (6) \*\* Table 67-101(C)(4).

**TRAFFIC CONTROL PLAN**

SCALE: NOT TO SCALE



PROJECT NO: SCAB013267  
 DRAWN BY: DK  
 CHECKED BY: JM

0	C1/B1/1	90% CONSTRUCTION
1	09/28/17	REVISED PER PG&E STANDARDS

IT IS A VIOLATION OF THE LAW FOR ANY PERSON UNLESS THEY ARE ACTING UNDER THE DIRECTION OF A LICENSED PROFESSIONAL ENGINEER, TO ALTER THIS DOCUMENT

SCAB013267  
 OAKLAND, CA 94602  
 (E) 28'-0" STEEL LIGHT POLE

SHEET TITLE  
**TRAFFIC CONTROL PLAN**

SHEET NUMBER  
**TC-1**



8/2/17

CHAMPION ST., S. OF PALMETTO ST.  
OAKLAND, CA

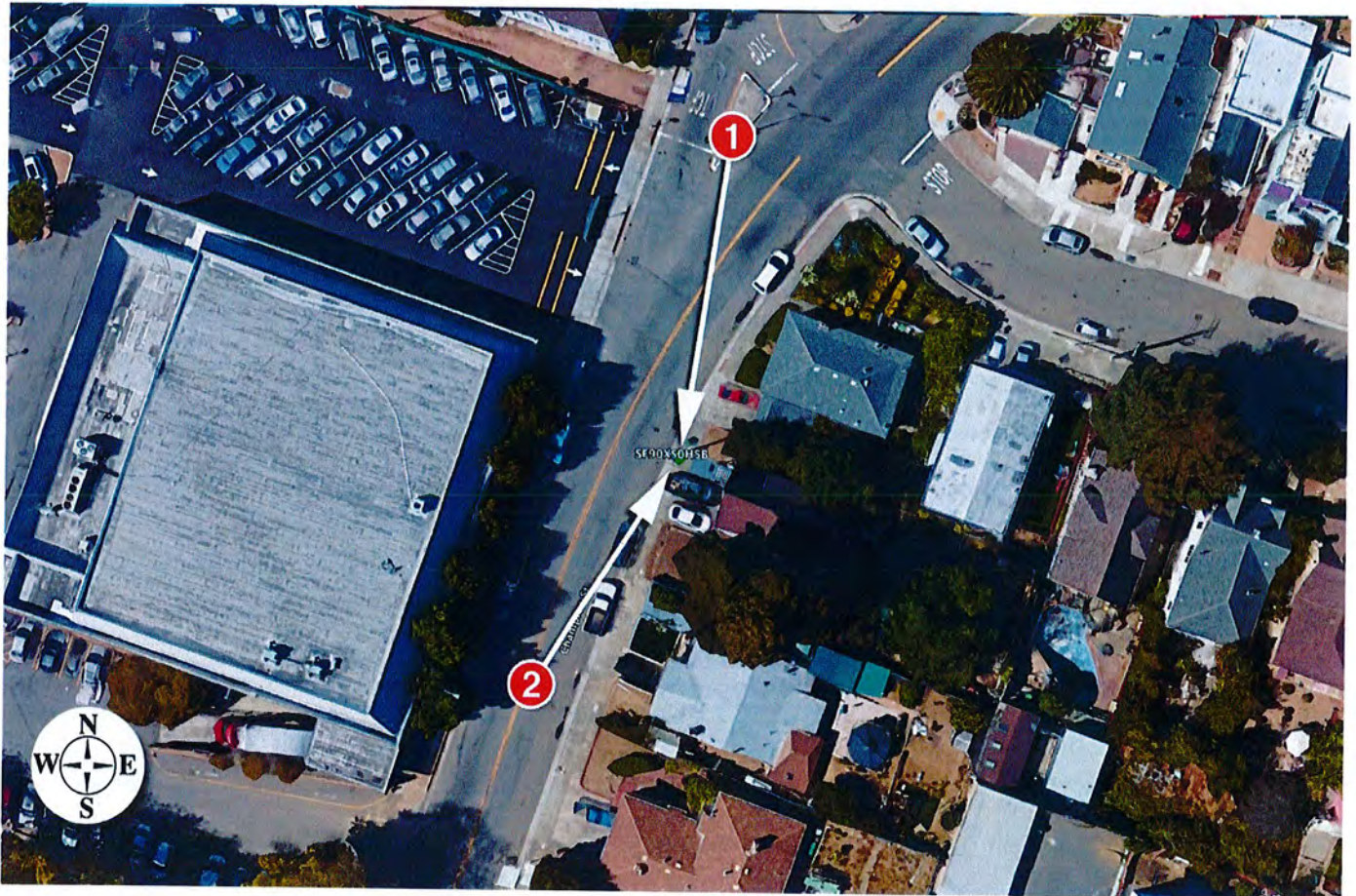





Existing

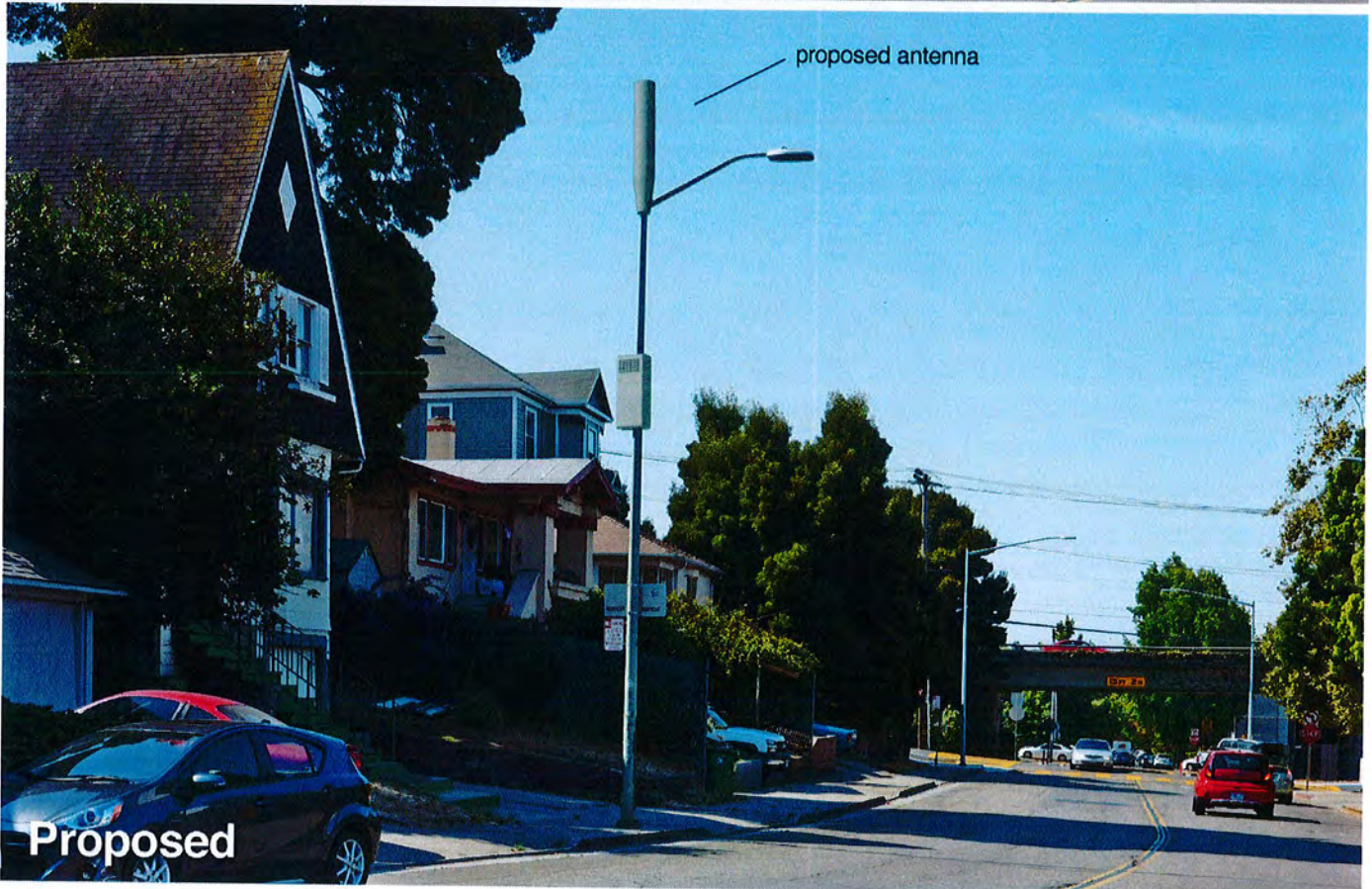

proposed antenna

Proposed



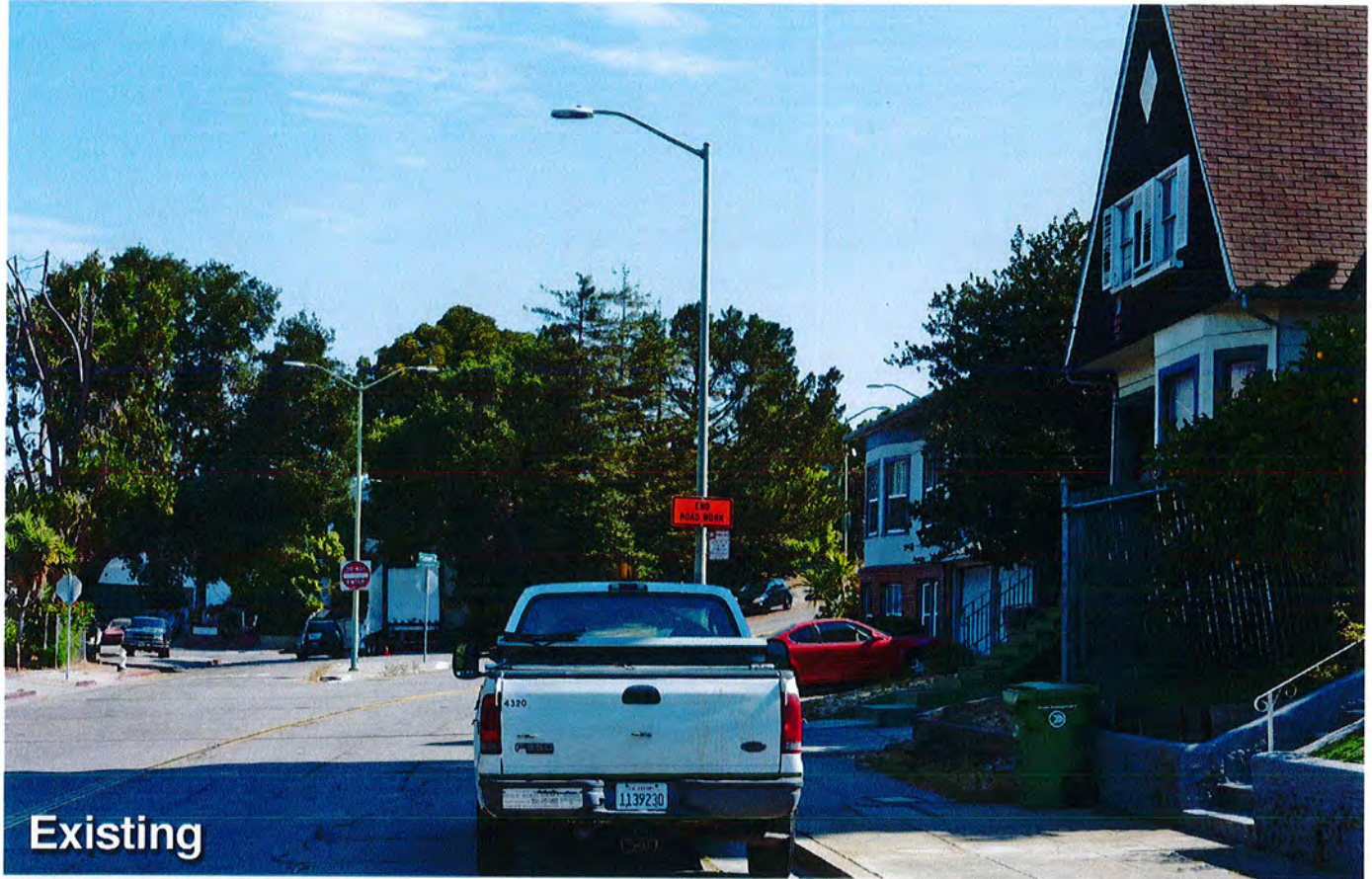

**Existing**



proposed antenna

**Proposed**



## **Alternative Site Analysis**

### **Proposed Small Cell Wireless Facility**

**Applicant:** Mobilitie, LLC

**Site ID:** 9CAB013267-B/SF90XS0H5B

**Nearest Site Address:** Public Right of Way 3426 Champion Street, Oakland CA 94602

**Latitude/Longitude:** (37.79888800, -122.21511300)

Mobilitie considered alternative sites on other street lights and utility poles in this area, but found them to not to be as desirable when taking into consideration coverage goals, constructability, geographic topography of the surrounding area, and potential visual impact in the surrounding area. The proposed location is desirable because of the limited obstructions in the area, allowing our antenna to effectively propagate a signal. Furthermore, the proposed location is the optimal solution for providing maximum coverage to the surrounding area identified. Additionally, by locating on an existing street light with equipment concealed, visual impact in the surrounding area is minimized.

Mobilitie is a privately held, CLEC (Competitive Local Exchange Carrier) regulated by the California Public Utilities Commission (CPUC) to provide telephone related services. By proposing this location on an existing street light in the public right of way, Mobilitie is proposing an appropriate co-location to existing infrastructure according to our rights under the CPUC.

The alternative locations that Mobilitie considered include, but are not limited to, the sites listed below:

Alternate 1 (37.798251, -122.215338)/ Montana St/Lincoln Ave: This wooden utility pole is located approximately 250' south of our proposed site. This wooden utility pole is overloaded with the existence of a power risers running up the poles, overhead wires, and associated utility lines running through the pole. There is also an existing luminaire arm and wooden crossbars on this pole. These obstructions make this pole unusable for the constructability and functionality of our proposed small cell equipment.

Alternate 2 (37.798988, -122.214597) Palmetto St./Lincoln Ave.: This wooden utility pole is located approximately 175 ft. northeast of our proposed site. This wooden utility pole is overloaded with the existence of a power risers running up the poles, overhead wires, and associated utility lines running through the pole. There is also existing equipment, a luminaire arm, and guy wires anchoring the pole. These obstructions make this pole unusable for the constructability and functionality of our proposed small cell equipment.

## RF-EME Measurements & Compliance Report

Site ID: SF90XS0H5B  
Site Name: 9CAB013267\_B  
Market/Region: SF Bay  
Report Generated: 2018-05-18

Latitude: 37.7989  
Longitude: -122.2151  
Site Type: Light Pole

### Compliance Status

Proposed equipment at the site is compliant with FCC guidelines for General Population environments.

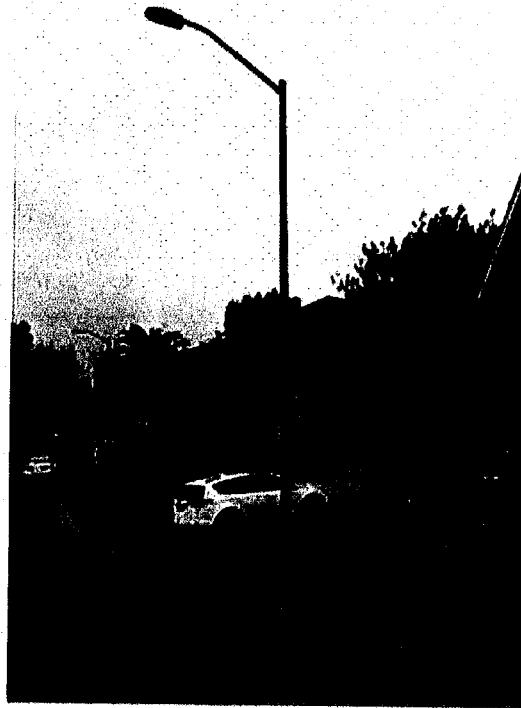

Prepared in support of  
application submitted by:  
Mobilitie, LLC  
2220 University Drive,  
Newport Beach, CA 92660



**Table of Contents**

Executive Summary ..... 3  
Statement of Compliance ..... 4  
FCC Rules and Regulations ..... 5  
Methodology ..... 6  
Antenna Inventory ..... 7  
Preparer Certification ..... 8

**List of Tables**

Table 1: Summary of Calculated Maximum Permissible Exposure from EME Analysis 4  
Table 2: FCC Limits for General Population/Uncontrolled Exposure ..... 4  
Table 3: FCC Limits for Occupational/Controlled Exposure ..... 4  
Table 4: Antenna Inventory ..... 7  
Table 5: Antenna Operating Power ..... 7

## **Executive Summary**

Mobilitie LLC has requested a detailed Radio Frequency (RF) analysis to determine whether the proposed communications site, 9CAB013267\_B, is in compliance with Federal Communication Commission (FCC) Rules and Regulations for ElectroMagnetic Emissions (EME).

This report addresses exposure to radio frequency electromagnetic fields in accordance with the FCC Rules and Regulations for all individuals, classified in two groups, "Occupational or Controlled" and "General Population or Uncontrolled."

**As explained in the subsequent sections, based on worst-case predictive modeling, the emitted power density from Mobilitie's proposed antennas at the site does not exceed the FCC Occupational limit or General Population limit. Modifications to the design will result in a power density value that is lower than the values presented here.**

## Statement of Compliance

Predictive modeling conducted using the Original Equipment Manufacturer's (OEMs) specifications for radio and antenna performance at 2496 MHz indicates there will be no exposure due to the carrier's proposed equipment on accessible walking surface at this site (6 ft above ground-level) that exceeds the FCC's General Population or Occupational Exposure limits. Thus, the proposed equipment at the site is compliant with FCC guidelines for General Population and Occupational Exposure environments.

Table 1: Summary of Calculated Maximum Permissible Exposure from EME Analysis

Test Location	% of FCC General Public/ Uncontrolled Exposure Limit	% of FCC Occupational/ Controlled Exposure Limit	Power Density (mW/cm <sup>2</sup> )	Compliance Status
6ft above ground level	5.7	1.1	<b>0.057</b>	Compliant

Table 2: FCC Limits for General Population/Uncontrolled Exposure

Frequency Range (MHz)	Electric Field Strength, E (V/m)	Magnetic Field Strength, H (A/m)	Power Density, S (mW/cm <sup>2</sup> )	Averaging Time  E  <sup>2</sup> ,  H  <sup>2</sup> or S (minutes)
0.3 - 1.34	614	1.63	100	30
1.34 - 30	824/f	2.19/f	180/f <sup>2</sup>	30
30 - 300	27.5	7.2999	0.2	30
300 - 1500	-	-	f/1500	30
<b>1500 - 100000</b>	-	-	<b>1</b>	<b>30</b>

Table 3: FCC Limits for Occupational/Controlled Exposure

Frequency Range (MHz)	Electric Field Strength, E (V/m)	Magnetic Field Strength, H (A/m)	Power Density, S (mW/cm <sup>2</sup> )	Averaging Time  E  <sup>2</sup> ,  H  <sup>2</sup> or S (minutes)
0.3 - 3.0	614	1.63	100	6
3.0 - 30	1842/f	4.89/f	900/f <sup>2</sup>	6
30 - 300	61.4	0.1630	1	6
300 - 1500	-	-	f/300	6
<b>1500 - 100000</b>	-	-	<b>5</b>	<b>6</b>



## FCC Rules and Regulations

In 1996, the Federal Communication Commission (FCC) adopted regulations for the evaluating of the effects of RF emissions in 47 CFR § 1.1307 and 1.1310. The guideline from the FCC Office of Engineering and Technology is Bulletin 65 (OET Bulletin 65), Evaluating Compliance with FCC Guidelines for Human Exposure to Radio Frequency Electromagnetic Fields, Edition 97-01, published August 1997. Since 1996 the FCC periodically reviews these rules and regulations as per their congressional mandate.

FCC regulations define two separate tiers of exposure limits: Occupational or "Controlled environment" and General Population or "Uncontrolled environment". The General Population limits are generally five times more conservative or restrictive than the Occupational limit. These limits apply to accessible areas where workers or the general population may be exposed to Radio Frequency (RF) electromagnetic fields. Occupational or Controlled limits apply in situations in which persons are exposed as a consequence of their employment and where those persons exposed have been made fully aware of the potential for exposure and can exercise control over their exposure.

An area is considered a Controlled environment when access is limited to these aware personnel. Typical criteria are restricted access (i.e. locked or alarmed doors, barriers, etc.) to the areas where antennas are located coupled with proper RF warning signage. A site with Controlled environments is evaluated with Occupational limits. All other areas are considered Uncontrolled environment. If a site has no access controls or no RF warning signage it is evaluated with General Population limits.

The theoretical modeling of the RF electromagnetic fields has been performed in accordance with OET Bulletin 65. The Maximum Permissible Exposure (MPE) limits utilized in this analysis are outlined in the following diagram:

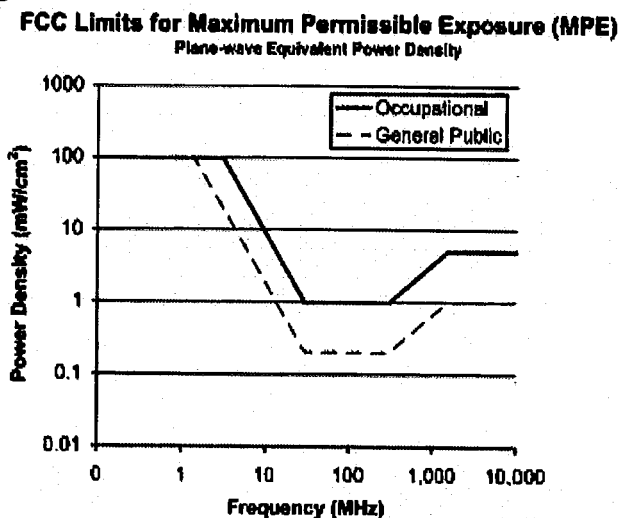

Federal Communication Commission Evaluating Compliance with FCC Guidelines for Human Exposure to Radiofrequency Electromagnetic Fields p. 67-68

## Methodology

RoofView® is a powerful, Excel based software analysis tool for evaluating Radio Frequency (RF) field levels at telecommunications sites that are produced by antennas of the type commonly used in the cellular, paging, SMR, PCS and conventional two-way radio communication services.

RoofView® uses a near-field method of computing the field based on the assumption that the total input power delivered to the antenna (P), at its input terminal, is distributed over an imaginary cylindrical surface surrounding the antenna (see Figure 1). The height of the cylinder (h) is equal to the aperture height of the antenna while the radius (R) is the distance from the antenna at which the field power density is to be computed.

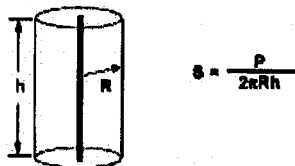

The modeling was conducted with the antennas operating at 100% capacity, all antenna channels transmitting simultaneously and the radio transmitters operating at full power. Obstructions (trees, buildings etc.) that would normally attenuate the signal are not taken into account. As a result, the predicted signal levels are more conservative (higher) than the actual signal levels would be during normal operations. The modeling calculations were made for a 40x 40 foot area with the equipment at the center.

Backhaul has been modeled as a User Equipment Relay (UER) operating at an aggressively low height of 17.5 ft to reflect worst-case exposure. As height increases, the impact of the UE Relay reduces even further. Because of its low power level compared to the RF antenna, the contribution of the UE Relay to the overall EME of the site is minimal and will not impact the calculated compliance levels for Maximum Permissible Exposure as calculated in this EME report.

The site has been modeled with these assumptions to calculate the maximum RF energy density as a worst-case scenario. If actual power density measurements were made, these are expected to be below the levels shown in this report.

## Antenna Inventory

The Antenna Inventory shows all transmitting antennas at the site. This inventory was provided by the customer, and was utilized to perform theoretical modeling of RF emissions.

The antenna inventory and operating power includes the following information:

- Wireless applicant name
- Antenna type, manufacturer and model
- Frequency or frequency band
- Transmitter power, in Watts
- Effective Radiated Power (ERP), in Watts

Table 4: Antenna Inventory

Antenna ID	Wireless Applicant	Antenna Type	Frequency (MHz)	Technology	Mfg.	Model	Aperture (ft.)
1	Mobilite	RF Omni	2496	LTE	Alpha Wireless	AW3477-S	2.56
2	Mobilite	UER Directional	2496	LTE	Airspan	IR460-SPB-ST1-P-0	1.10

Table 5: Antenna Operating Power

Antenna ID	Frequency (MHz)	# of Transmitters	Power per Transmitter (W)	Gain dBd	ERP (W)	Horizontal BeamWidth (deg)	Z (6 ft. above ground)
1	2496 (Omni)	2	20.00	6.35	172.58	360	25
2	2496 (UE Relay)	1	0.20	9.85	1.93	35	11



## **Preparer Certification**

The scope of work of this report is limited to an evaluation of the electromagnetic energy emissions field generated by the antennas listed in the report. The engineering and design of all related structures as well as the impact of the antennas on the structural integrity of the design are specifically excluded from the scope of work.

As the preparer of this report, I am fully aware of and familiar with the rules and regulations of both the Federal Communications Commission (FCC) and the Occupational Safety and Health Administration (OSHA), both in general and specifically as they apply to the guidelines for human exposure to Radio Frequency (RF) radiation.

I have reviewed this RF exposure assessment and compliance report and believe it to be both true and accurate to the best of my knowledge.

Certified By: \_\_\_\_\_

A handwritten signature in black ink, consisting of a series of loops and a long horizontal stroke, positioned over a solid horizontal line.

Title: Senior Engineer, EME Certification Team



36-4